

WEEBERMOBILE



CHRISTIAN F. WEEBER, JR.,
INVENTOR, ENTREPRENEUR
AND MANUFACTURER



GEOFFREY N. STEIN

NEW YORK STATE MUSEUM RECORD 6

WEEBERMOBILE

Christian F. Weeber, Jr.
Inventor, Entrepreneur, and Manufacturer

By
Geoffrey N. Stein



New York State Museum
Albany, NY

THE UNIVERSITY OF THE STATE OF NEW YORK

Regents of The University

BETTY A. ROSA, <i>Chancellor</i> , B.A., M.S. in Ed., M.S. in Ed., M.Ed., Ed.D.	Bronx
T. ANDREW BROWN, <i>Vice Chancellor</i> , B.A., J.D.	Rochester
JAMES R. TALLON, JR., B.A., M.A.	Binghamton
ROGER TILLES, B.A., J.D.	Great Neck
LESTER W. YOUNG, JR., B.S., M.S., Ed.D.	Beechhurst
CHRISTINE D. CEA, B.A., M.A., Ph.D.	Staten Island
WADE S. NORWOOD, B.A.	Rochester
KATHLEEN M. CASHIN, B.S., M.S., Ed.D.	Brooklyn
JAMES E. COTTRELL, B.S., M.D.	New York
JOSEPHINE VICTORIA FINN, B.A., J.D.	Monticello
JUDITH CHIN, M.S. in Ed.	Little Neck
BEVERLY L. OUDERKIRK, B.S. in Ed., M.S. in Ed.	Morristown
CATHERINE COLLINS, R.N., N.P., B.S., M.S. in Ed., Ed.D.	Buffalo
JUDITH JOHNSON, B.A., M.A., C.A.S.	New Hempstead
NAN EILEEN MEAD, B.A.	Manhattan
ELIZABETH S. HAKANSON, A.S., M.S., C.A.S.	Syracuse
LUIS O. REYES, B.A., M.A., Ph.D.	New York

Commissioner of Education and President of The University

MARYELLEN ELIA

Executive Deputy Commissioner

ELIZABETH R. BERLIN

Director, New York State Museum

MARK SCHAMING

Director, Research and Collections Division

JOHN P. HART

The State Education Department does not discriminate on the basis of age, color, religion, creed, disability, marital status, veteran status, national origin, race, gender, genetic predisposition or carrier status, or sexual orientation in its educational programs, services and activities. Portions of this publication can be made available in a variety of formats, including braille, large print or audio tape, upon request. Inquiries concerning this policy of nondiscrimination should be directed to the Department's Office for Diversity and Access, Room 530, Education Building, Albany, NY 12234.

WEEBERMOBILE

*Christian F. Weeber, Jr.
Inventor, Entrepreneur, and Manufacturer*

By
Geoffrey N. Stein

2016

Dedicated to the memory of Marion Gladys Weeber (Welsh), who made possible documenting her father's life and work.

©2016 The New York State Education Department

Published in the United States of America

ISSN 2156-6178

ISBN 978-1-55557-292-1

ACKNOWLEDGEMENTS

Marion G. Weeber (Welsh), Christian F. Weeber's daughter, through preservation of artifacts, records and knowledge, made possible this book documenting portions of her father's life as an inventor and entrepreneur. In the early 1930s, Marion identified Christian Weeber artifacts given to the State Museum. She remained dedicated to preserving the Weeber history through a bequest in 2000. As a former curator at the New York State Museum, I remain grateful, having learned much from Marion Weeber during my contacts with her over a quarter century.

I encountered Weeber artifacts early in my career at the State Museum. In 1970, I contacted Marion and her sister, Gretchen, to see if I could learn more about Christian and to ask about other artifacts that might have survived. From that point, the Weeber museum collection grew with additional artifacts and information about Christian. Later in my years at the Museum, I contemplated a Christian Weeber biography. The writing of this book began after Marion's death in 2000.

Interns and volunteers at the museum assisted in the research. In 2006, Eric Zenker, a State University at New York at Albany student, checked Christian Weeber's automotive work in the 1910s; and Emily Wright, a Barnard College student, looked into Weeber's automobile inventions and enterprises. In 2007, Danielle N. Brignola, also a University of Albany student, checked local newspapers to learn more about Weeber's automobile activities. She also assisted in cataloguing an extensive collection of Weeber advertising electrotypes and stereotypes. In 2007 and 2008, Myra Rynderman, a State Museum volunteer, continued to look at Albany newspapers and subsequently read an earlier version of this manuscript.

When I retired as a curator from the New York State Museum in 2010, this manuscript had not yet been published. Since then, I have been a volunteer historian consultant at the museum, where I learned that museum publications were now available on its website. I asked my colleagues if the Christian Weeber biography might be made avail-

able to the public. In 2013, John Hart, Director of Research and Collections and head of museum publications, reviewed the manuscript and chose to move forward with it.

Jennifer Lemak, senior historian, became manager of the book project. Bridget Enderle, a history technician at the museum, served as graphics coordinator. John Yost, from the museum, photographed the artifacts and scanned historical photos. Mary Yamin-Garone served as editor, and Scott Cardinal provided the layout. Leigh Ann Smith, museum graphic artist, designed the cover. The author is grateful to all who made Christian Weeber's biography possible. I apologize for any names that may have been overlooked during the many decades of research, conservations of Weeber artifacts, opening of several Weeber exhibits at the State Museum and preparing the current preparation for *Weebermobile: Christian F. Weeber, Jr. – Inventor, Entrepreneur, and Manufacturer*.

Geoffrey N. Stein
New York State Museum
June 2015

CHRISTIAN WEEBER, JR. TIMELINE

1872	Christian F. Weeber, Jr., born July 15, 1872, in Albany, New York, to Christian F. Weeber, Sr., a butcher, and Dorothea Ammon Weeber.
1878	Christian Weeber, his parents and siblings move to a farm in Watervliet (now Loudonville in the Town of Colonie).
1880's	Attends Albany High School.
1893	Graduates from Pratt Institute with an engineering degree.
1895	Works at the General Electric Company in Schenectady and resides with his brother, Louis F. Weeber. Christian begins developing an internal combustion engine and an airplane.
1896	Weeber opens a bicycle shop on Central Avenue in Albany.
1898	Weeber begins to fabricate an automobile.
1900's	Weeber begins to invent, fabricate and manufacture automobile components.
1900-1905	C.F. Weeber Manufacturing Works manufactures internal combustion engines for stationary applications.
1902	Weeber leases a facility for the C. F. Weeber Manufacturing Works on Sherman Street in Albany.
1902-1910	Weeber muffler manufactured and sold. Weeber steering and braking device manufactured. Separate steering gear.
1903	Surviving Weebermobile fabricated.
1904	Weeber key plug switch advertised.
1904	Weeber marries Pauline Paul on June 29, 1904. Couple rent two-family home on 272 Western Avenue in Albany.
1905	Marion Gladys Weeber born; married surname Welsh; dies in 2000.

1906-1907	Weeber gives up plans to manufacture automobiles. Instead he partners with Willard J. Sutherland, Sr., of the Central Automobile Company, to sell Maxwell and Ford automobiles.
1906	Weeber moves his Weeber Works facility from Sherman Street to a new building on Central Avenue.
1908-1910's	Weeber Manufacturing Works sells automobiles, parts and repairs.
1906-1911	Weeber advertises shock reliever; Fletcher Battershall invention.
1907-1910	C. F. Weeber Manufacturing Works terminates its connection with the Central Automobile Company, but continues to sell and distribute Ford cars.
1907-1908	Creates valve tool and wheel puller.
1909-1920	Weeber Manufacturing Works sells Ohio, Chase and Allen, Standard, American, and Mais automobiles.
1910-1920	C. F. Weeber Manufacturing Works sells the Haynes automobile line, the longest-lived of Weeber's automobile agencies.
1911-1915	C. F. Weeber Manufacturing Works acquires Studebaker line; first sold as E-M-F and Flanders cars.
1909-1910	Builds house on Manning Boulevard in Albany.
1913	Ruth Gretchen Weeber born; dies in 1984.
1916-1920's	Acquires a building adjacent to the C. F. Weeber Manufacturing Works facility for operating his Albany Storage Battery Company.
1910's-1920's	Develops new inventions including rails (railroad), traction device for motor vehicle wheels, tire carrier for motor vehicles and chains for motor vehicle tires.
1920	Abandons the sale of cars. Rents the first floor of the manufacturing facility and continues his research on the second floor.
1927	Patent granted for Weeber's internal combustion engine fuel system. Continues development and additional patent applications and trials.
1920s-1932	Develops the Weeber "Utililzer" helicopter design.
1932	during hernia surgery, Christian Weeber, Jr. dies on September 18, 1932.

CONTENTS

Acknowledgements	v
Christian Weeber, Jr. Timeline	vi
Contents	viii
List of Figures	xi
List of Tables	xv
Introduction	1
Chapter 1. Childhood, Education, Employment and the Bicycle Business	3
Chapter 2. Marriage and Family	9
Life Apart from Work and Family	14
Chapter 3. Automobile Builder and Manufacturer; The Surviving Weeber Automobiles; Weeber as Automobilist	17
What Did Christian Weeber Make and What Did He Buy in Building the Weeber Cars?	26
How Many Weeber Cars?	28
Other Weeber Artifacts at the New York State Museum	31
Christian Weeber as an Automobilist	31
Chapter 4. Inventions and Products to 1910	35
Engines	35
Muffler	38
Steering and Braking Device and Steering Gear	46
Key Plug Switch	49
Shock Reliever	49
Wheel Puller	62
Valve Tool	64
General Manufacturing, Unidentified Products, and Unidentified Projects	66
Advertising	68
Trade Shows and other Selling Media	73
Chapter 5. The Weeber Enterprises: C. F. Weeber Manufacturing Works; Central Automobile Com- pany; Albany Storage Battery Company	74
The Central Automobile Company	74
C. F. Weeber Manufacturing Works Employees	75
Christian Weeber and Trade Organizations	76
Real Estate	77
Equipment Catalogues in the Weeber Collection at the New York State Museum	85

Utilities	85
Communications	89
Miscellaneous Operational Expenses	90
Chapter 6. Automobile Dealer	93
Tools and Equipment	94
Consumable Goods (oil, gasoline, acetylene, etc.)	95
Hard Goods (Repair Parts, Accessories)	102
Other Supplies, Services and Sublet Repairs	132
In-House Repair Business and Brief Look at the Used Car Business	137
Chapter 7. Agent for the Maxwell-Briscoe Motor Company of Tarrytown, New York and the Corbin Motor Vehicle Corporation of New Britain, Connecticut	148
1906-1907	148
Chapter 8. Agent for the Ford Motor Company of Detroit, Michigan	155
1906 - 1908 Model Years	155
1909 Model Year	172
1910 Model Year	180
Chapter 9. Agent for the Haynes Automobile Company of Kokomo, Indiana	191
1910 Model Year	191
1911 Model Year	198
1912 Model Year	200
1913 Model Year	201
1914 Model Year	202
1915 Model Year	203
1916 Model Year	205
1917 Model Year	205
1918 Model Year	205
1919 Model Year	208
1920 Model Year	209
Chapter 10. Agent for the Jewel Carriage Company of Carthage, Ohio	210
Chapter 11. Agent for the E-M-F Company of Detroit, Michigan and the Studebaker Brothers Company of New York, New York (Subsidiary of Studebaker Brothers Company of South Bend, Indiana)	214
1911 Model Year	214
1912 Model Year	217
1913 Model Year	220
1914 Model Year	223
1915 Model Year	223
Chapter 12. Agent for the Allen Motor Company of Fostoria, Ohio	226
Chapter 13. Agent for the Standard Steel Car Company of Pittsburgh, Pennsylvania (factory at Butler)	227
1916 Model Year	227
1917 Model Year	227
1918 Model Year	228
1919 Model Year	228

Chapter 14. Agent for Various Truck Manufacturers: Chase Motor Truck Company of Syracuse, New York	231
American Motor Truck Company of Lockport, New York	234
Mais Motor Truck Company of Indianapolis, Indiana	235
Other Motor Trucks Considered for Weeber Agency Status	238
Automobile Lines Possibly Considered by Christian Weeber for Agency Representation	240
Chapter 15. C. F. Weeber Manufacturing Works After Discontinuance of New Automobile Sales	243
Albany Storage Battery Company	243
C. F. Weeber Manufacturing Works in the 1920s	247
Chapter 16. Post-1910 Inventions and Products Development, Manufacture and Distribution	248
Rails	248
Traction Rings	249
Tire Carrier	250
Tire Chains	250
Fuel Systems	251
“Utilizer” Helicopter	260
Chapter 17. Death and Legacy	264
Exhibits	268
Final Observation	272
Bibliography	273

LIST OF FIGURES

1.1	Photographic print, 1873. Christian F. Weeber, Jr. as a baby photographed by George A. Mosher, 444 Broadway, Albany. NYSM Collection, H-1984.42.1.	3
1.2	Inlaid parlor table made by Christian F. Weeber, Jr. with wood from his father's Loudonville farm, 1886. NYSM Collection, H-1986.58.15.	5
1.3	Two steam engine models built by Weeber while a student at Pratt. NYSM Collection H-1933.6.15 and H-1933.6.31.	7
1.4	Christian Weeber in the doorway of his bicycle shop. Brother Emil (who eventually took over the bicycle business) is to the right of the entrance. NYSM Collection H-1970.110.31. . .	7
1.5	Business card for Christian Weeber's bicycle enterprise, dated as 1895. NYSM Collection H-1970.110.34.	8
2.1	Pauline Paul Weeber, 1904. Photograph the gift of R. Gretchen Weeber and Marion Weeber Welsh, NYSM Collection H-1973.110.4.	9
2.2	Photograph of Pauline Weeber's duster worn on her automobile honeymoon. NYSM Collection, H-1973.110.1-2.	10
2.3	The Christian Weeber family, perhaps in front of the Delmar boarding house where the family spent weekends.	12
2.4	Unidentified photograph likely depicting Marion Weeber as a child. NYSM Collection, H-2000.39.118.	12
2.5	Andiron designed by Christian Weeber for his home on Manning Boulevard in Albany. NYSM Collection, H-2000.39.7 A-B.	13
2.6	The Weeber house at 106 Manning Boulevard in Albany, c.1915. Marion Weeber wrote the house was designed and built by her father. NYSM Collection, H-1987.39.2.	13
3.1	Photograph of the earlier and more primitive of the two incomplete automobiles. NYSM Collection, H-1933.6.5.	19
3.2	Incomplete automobile removed from the facility on Central Avenue after Christian Weeber's death. NYSM Collection, H-1933.6. 73 and H-1933.6.108.	20
3.3	Christian and Pauline Weeber in the Weeber automobile decorated for the Albany Halloween parade on Western Avenue in Albany, c. 1905. NYSM Collection, H-1970.110.68.	23
3.4	Christian Weeber's final driver's license. NYSM Collection, H-1996.31.5.	32
3.5	Automobilist Christian Weeber gathered with family and friends at brother's Saratoga home, 1904. NYSM Collection, H-1973.110.3.	32
3.6	Christian Weeber's Albany Automobile Club lapel pin. NYSM Collection, H-1970.110.1. . . .	34
4.1	Christian Weeber's drawing tools, some of which date from his student days at Pratt Institute. NYSM Collection, H-1986.58.2-10 and H-1975.74.40-44.	36
4.2	Display advertisement for Weeber engines in Albany city directory, 1905, p. 923. New York State Library, Manuscripts and Special Collections.	36
4.3	Two Weeber stationary engines survive in the New York State Museum. NYSM Collection, H-1933.6.120 and H-1933.6.6.	37
4.4	Photography of a Weeber engine for publicity purposes. NYSM Collection, H-1933.6.116. . .	39

4.5	Patent illustration of Weeber muffler (#692,094). Courtesy of http://www.uspto.gov United States Patent Office.	40
4.6	Sketch of the water-cooled muffler installation and W.O. Knudsen letter. NYSM Collection, H-2000.39.NN.	44
4.7	Display muffler advertisement from <i>The Horseless Age</i> , January 10, 1906, p. LII. NYSM Collection, H-1933.6.338.	47
4.8	Patent illustration of the Weeber combined steering and braking device. Courtesy of http://www.uspto.gov United States Patent Office.	48
4.9	Weeber Shock Reliever advertisement appearing in the <i>Official Manual Guide and Book of Reference of the Professional Chauffeurs' Club of America</i> , 1907. Courtesy of the Library of Congress.	52
4.10	Weeber Shock Reliever presented in the wholesale <i>Post & Lester Motor Car Supplies Catalogue</i> , 1907. NYSM Collection, H-1933.6.193.	56
4.11	Fletcher W. Battershall, c. 1915. NYSM Collection, H-2000.39.NN.	57
4.12	Fletcher W. Battershall, c. 1925. NYSM Collection, H-2000.39.NN.	57
4.13	Proof sheet with Weeber Manufacturing Works corrections for a wheel puller advertisement in <i>The Automobile</i> , August 2, 1908. NYSM Collection, H-1970.110.8.	63
4.14	Weeber valve tool featured in <i>The Horseless Age</i> , February 1907. Courtesy of New York State Library, Manuscripts and Special Collections.	64
5.1	Photograph of Willard J. Sutherland, Sr., Christian Weeber's partner in the Central Automobile Company, printed in <i>The Argus</i> , March 6, 1910.	75
5.2	Christian Weeber and Weeber Manufacturing Works colleagues posed in the showroom at 170-172 Central Avenue with 1910 model autos.	77
5.3	Photograph of Alfred C. Dederick behind the wheel of a Standard car in front of the C. F. Weeber Manufacturing Works showroom	78
5.4	Photographic Print, c. 1909. "C. F. Weeber Mfg. Works. Salesroom & Service Repair Shop Haynes & Ford Cars—Agency 1909."	86
5.5	Postcard, c. 1909. Interior view of the machine shop at the rear of 170-172 Central Avenue.	87
5.6	170-172 Central Avenue, Albany, 1930s.	92
6.1	Photograph of Cover of Acme Red Letter Tires booklet with Weeber imprint.	112
6.2	The Stepney Spare Wheel Company letterhead. NYSM Collection, H-2000.39.NN.	116
6.3	Invoice for a K-W magneto shipped in May 1909 via American Express to the Weeber Manufacturing Works, May 22, 1909.	121
6.4	Cutout received by the New York State Museum with the Weeber material removed from the buildings at 168-170-172 Central Avenue.	123
6.5	Photograph of sales sample of Stewart Model B speedometer, c. 1910, on a stand for use in selling from the C. F. Weeber Manufacturing Works facility on Central Avenue in Albany.	125
6.6	The Troy Carriage Sun Shade catalogue, 1909. Christian Weeber ordered for a customer, probably for installation on a Ford car.	127
6.7	Emil Grossman letter, August 26, 1909. Note the illustration where the cannon is shooting a load of campaign mail. NYSM Collection, H-1933.6.NN.	130
6.8	John Kingsbury bill with Christian Weeber's penciled notations, January 1, 1911. NYSM Collection, H-2000.39.NN.	146
7.1	Photographs of Willard J. Sutherland (bottom row, center) and Christian Weeber (3 rd row, second from right) in Albany Automobile Dealers' Association photograph, 1921. H-1970.110.51.	149
7.2	Photograph of Weeber family in a Maxwell touring car, probably a Model H of 1906 or HB of 1907, Quail Street and Western Avenue in Albany in 1906.	153
7.3	Photograph of Weeber family in a Maxwell car, c. 1907.	154

8.1	Photograph of Model N Ford in front of 168 Central Avenue. NYSM Collection, H-2000.39.105.	155
8.2	Display advertisement from <i>The Argus</i> , March 1, 1908. Courtesy of New York State Library, Manuscripts and Special Collections.	161
8.3	Display advertisement from <i>The Argus</i> , April 19, 1908. Courtesy of New York State Library, Manuscripts and Special Collections.	165
8.4	<i>Ford Times</i> , May 15, 1909. The New York Branch of the Ford Motor Company decorated for an automobile carnival. NYSM Collection, H-2000.39.151.	168
8.5	Photograph of Weeber driving a Ford Model S in the First Annual Hill Climbing Contest of the Albany Automobile Club, May 23, 1908. NYSM Collection, H-1987.39.9.	170
8.6	Trophy awarded Christian Weeber for his Menands Hill Climb victory, May 23, 1908. NYSM Collection, H.-1970.110.43.	170
8.7	H. B. Harper letter to Weeber Mfg. Works, April 28, 1909 with what appears to be one of Christian Weeber's drawings on it.	174
8.8	Photograph of Weeber Mfg. Works facility exterior with Fords and personnel, including Christian Weeber, c. 1909.	178
8.9	Ford Motor Cars Catalogue, 1910. Polychrome cover (unusual for 1910 period) and page describing the Ford town car ("splendid taxicab proposition"). NYSM Collection, H-2000.39.87.	185
9.1	The C.F. Weeber Mfg. Works displayed cars in the first Albany Automobile Dealers' Association auto show at the Washington Avenue Armory in March 1910.	193
9.2	<i>Haynes Year Book</i> sales catalogue, 1910. NYSM Collection, H-2000.39.95.	193
9.3	Reproduction of Ford Motor Company–National Surety Company bond. <i>Ford Times</i> , vol. 3, no. 12, March 15, 1910, pp. 15-16.	196
9.4	Photographs of Haynes Model 19 coupe. This is the coupe-bodied Haynes that Christian Weeber had constructed for Dr. Shaw.	199
9.5	<i>Times Union</i> , February 18, 1913. Christian Weeber depicted in a caricature by Lorenzo W. Ford during the annual automobile show at the Washington Avenue Armory.	201
9.6	In the <i>Albany Evening Journal</i> , March 3, 1914, Weeber Mfg. Works display advertisement touted the Haynes Electric Gear Shift the day before the opening of the Albany Auto Show.	204
9.7	Photograph of automobile dealers in New York, c. 1916. Automobile Dealers Convention New York City (taken outside hotel).	206
9.8	Weeber exhibit at the Albany Automobile Dealers' Association show, 1917.	207
10.1	<i>The Argus</i> , June 20, 1909. Weeber Manufacturing Works display advertisement for the Ohio car. Courtesy of the New York State Library, Manuscripts and Special Collections.	211
10.2	Jewel Carriage Company's brochure, c. 1909. The engraving from the Ohio circular shows the Ohio 35-40 horsepower touring car.	213
11.1	<i>The [Albany] Argus</i> , February 16, 1913. Photograph portrait of Christian Weeber. Courtesy of the New York State Library, Manuscripts and Special Collections.	221
11.2	Photograph of Christian Weeber in a 1915 Studebaker automobile fitted with his Traction Rings invention and an improvised snow plow.	224
13.1	Photograph of Albany Automobile dealers luncheon, 1916.	228
13.2	Standard automobiles brochure, 1918.	229
13.3	<i>Albany Evening Journal</i> , February 15, 1919. Drawing of Christian Weeber (fifth from right) with other Albany automobile dealers depicted by cartoonist at the time of the annual car show in the Washington Avenue Armory.	230
14.1	<i>The Argus</i> , April 4, 1909. Christian Weeber advertised Chase trucks in the early spring of 1909. Courtesy of the New York State Library, Manuscripts and Special Collections.	232

14.2	Advertising card, c. 1909, for the light Chase truck.	233
14.3	Photograph of the 30-passenger American Motor Truck Company stage.	236
14.4	American Motor Truck Company letterhead, 1909-1910. NYSM Collection, H-1933-6.NN.	237
14.5	Mais instruction booklet cover. NYHSM Collection, H-1933.6.NN.	238
14.6	Photograph of a Mais truck with Weeber sign, c. 1912. NYSM Collection, H-1933.6.158.	239
16.1	Letterhead advertising the Weeber rail joint. NYSM Collection, H-1970.110.20A.	249
16.2	Photograph of wheel fitted with a traction ring for publicity purposes leaning against the show window of the C. F. Weeber Manufacturing Works at 170 Central Avenue in Albany. NYSM Collection, H-1987.39.10.	249
16.3	Weeber brochure for tire chains, 1923. NYSM Collection, H-1970.110.72A	252
16.4	Drawing of carburetion arrangement, February 14, 1925, of the "Fuel Transforming System."	253
16.5	This wooden model of an engine was used to display the pieces of a later fuel transforming system, apparently the version using a two-way valve.	254
16.6	Drawing, transformer parts, c. 1930. Sketches and notes in Christian Weeber's hand showing parts needed for 1,000 "Type C" Liquid Fuel Transforming devices. NYSM Collection, H-1979.23.11.	259
16.7	1927 Drawing of Christian Weeber done by Marion Weeber. NYSM Collection, H1974.122.1-2.	260
16.8	The fly ball governor, which Marion Weeber called "the only one in existence", was used by Christian Weeber in his Utilizer experiments. The device is engraved by hand inside "XYII." NYSM Collection, H-1974.36.1.	260
17.1	The LeBlond Machine Tool Company, 12-inch lathe used for many years by Christian Weeber.	267
17.2	Photograph of Marion Weeber in the Weebermobile, July 1976. NYSM Collection, H-1991.10.NN.	271

LIST OF TABLES

- 5.1 Fairbanks Sales to C. F. Weeber Manufacturing Works, 1906-1909; Invoices Surviving in the Collections of the New York State Museum 83
- 5.2 Companies listed in handbills and catalogues in the Weeber collection. 88
- 6.1 Invoices for gasoline purchases by the Weeber Manufacturing Company. 100
- 8.1 Invoice records for Ford cars sold by Weeber in 1910. 182

INTRODUCTION

Nearly three years after starting work as a history curator at the New York State Museum, the author became involved in refurbishing an automobile that had been in the museum's collection since the 1930s. In an attempt to learn more about the car and its builder, Christian F. Weeber, the author, sent a letter to a State Street address in Albany, which was the home of Weeber's daughter, R. Gretchen Weeber. He wrote that he understood (in error he subsequently discovered) the vehicle and other Weeber items had been given to the museum by Gretchen Weeber's sister, Marion G. Weeber. The car, he said, was:

... built by your father in 1903, and the engine was one manufactured by the C. F. Weeber Manufacturing Works in Albany. All this information I've gathered in the last few days from newspaper obituaries and city directories; we have very little information in our files... Since we are in the process of refurbishing the car, I am trying to put together as much data as I can both for use in the present work and for future reference. It appears to me that the Weebermobile, as the car is known, is very much significant in New York's automotive history, being one of the first built in the state. And your father, it would seem, played an important role in the development of the modern car. Thus, I am asking you whether you would supply me either from memory or records information both about the Weebermobile and about your father's career. I would be happy to talk to you at your convenience or respond to correspondence.¹

At the time the author's letter was written, Gretchen Weeber had retired from a supervisory position at the New York Telephone Company and relocated to Nantucket Island. Happily, the letter was forwarded to her and she replied. She indicated that it had been her mother, Pauline P. Weeber, rather than her sister Marion, who had been the source of the Museum's car and other Weeber items. She also wrote that she had telephoned Mar-

¹Geoffrey N. Stein to R. Gretchen Weeber, July 21, 1970.

ion, who promised to forward photographs and "detailed information."

Thus began a 35-year period of interaction between the author and the Weeber sisters, especially Marion. Many more objects associated with the life of Christian Weeber arrived at the museum. The information the author sought came forth, resulting in exhibits, articles, lectures and finally the present work.

While the author never met Gretchen Weeber, he visited with Marion several times between 1971 and 1995. After that first meeting in Albany in June 1971, he wrote:

I want to tell you how pleased I am that you spent Friday with us. It was a great pleasure for us all [at the State Museum] to meet you, and we look forward to seeing you soon again... Contemplating the things that you told us on Friday, I have the sensation that I know better what kind of person your father was. Especially your anecdotes about the dedication with which he pursued his experimentation have impressed me. I hope that we will be able to talk to you often again about your father's life as an inventor, engineer and mechanic.²

After her visit to the museum, Marion responded by letter to an observation by a museum colleague that her father had been a "tinkerer." She objected to that label as inappropriate and inaccurate and, in a few words, described her father's career:

As you know, Chris was a Pratt Institute trained engineer. He as a very deep thinker, and his experiments were sound and based on accurate data and the laws of nature. His advice was sought and always highly

²Geoffrey N. Stein to Marion Weeber Welsh, June 14, 1971. Marion Weeber replied on June 16, 1971, to thank the author "for your personal attention, which made my visit last week so pleasant. I was gratified to find you so interested in vintage cars, and machinery and so knowledgeable. I will shop New York antique shops and report my findings on horns and lamps [to replace missing Weeber auto parts]. Please let me know anytime I can be of further service and I hope you will visit my place when you get to New York.

respected throughout his career, and he was a successful manufacturer of improved patented automotive parts. He collected royalties on patents assigned for manufacture and sold some patents to other manufacturers. His auto sales and service shop, where he tested and developed many inventions was regarded as one of the best in the state.³

³Marion Weeber Welsh to Susan Kirkpatrick, June 17, 1971. Marion Weeber continued: "As a boy he was mechanical. He could understand what make things go and he could take them apart and put them back together again."

CHAPTER 1. CHILDHOOD, EDUCATION, EMPLOYMENT AND THE BICYCLE BUSINESS

Christian Friedrich (or Frederick) Weeber, Jr. was born on July 15, 1872, in Albany. His daughter, Marion G. Weeber Welsh, told the author that her father was born on the family farm in Loudonville. However, church records indicate that Christian Weeber's parents resided in Albany at the time of his birth.

Marion Weeber said her great-grandfather, also a Christian Friedrich Weeber, having sold a business and house, had emigrated to the United States from Moeckmuehl, Wuerttemberg, with his wife and children for "political reasons," specifically to avoid conscription.⁴ Among those Weeber children was another Christian F. (1839-1903). It is likely that Marion Weeber confused her great-grandfather and grandfather in relating the story of her family's immigration. If a man had been subject to conscription in the 1860s, it would have been the younger man, i.e., the Christian Weeber born in 1839. The author has found no record of a Christian Weeber born circa 1815 in the United States. On the other hand, the Christian Weeber born in 1839 can be documented by various church, census and directory listings showing him in America before 1866.

Marion noted that "Weeber" is "not an uncommon name among Lutherans. "Weber was the name taken in olden times by craftsmen who wove cloth. I've read that the monarchs of the time, bestoyed [sic] honors on those doing superior and creative works. In the case of the Webers, the extra "E" was added to their surname. That's why there are more Webers listed in your phone directory than Weebers."⁵

Christian F. Weeber, Sr., a butcher residing at 104 Nucella Street (later Fourth Avenue), first appeared in an 1866 Albany city directory. (Marion Weeber related that the immigrant, Christian Weeber, opened a butcher shop in Schenectady. She

⁴Marion Weeber in conversation with Geoffrey Stein, October 26, 1990. Hereafter, "Marion Weeber, October 26, 1990."

⁵Marion Weeber to Geoffrey Stein, November 14, 1990.



Figure 1.1: Photographic print, 1873. Christian F. Weeber, Jr. as a baby photographed by George A. Mosher, 444 Broadway, Albany. NYSM Collection, H-1984.42.1.

probably was thinking of the Schenectady market her uncle, Louis F. Weeber, operated in the 1890s.⁶

On October 22, 1865, Christian Weeber, Sr., married Dorothea Ammon (1842-1895), also a German immigrant, from Colberg in Sachsen-Meiningen. Church records alternatively list her given names as Anna Dorette or simply Dorette.⁷ Witnesses to the marriage at the German Evangelical Protestant Church at the corner of Alexander and Clinton Streets in the South End of Albany were Heinrich Woelfinger and Caroline Weeber, one assumes the groom's sister.⁸

Christian and Dorothea had seven children: John B. (sometimes Johann or Johannes Bernhard) Weeber, (1864-?);⁹ Christiane Louise (Louise, 1866-1889); Louis F. (baptized Christian Wilhelm Louis, 1867-1917); Christian, Jr., whose baptismal name was recorded as Christian Wilhelm Weeber; Lydia Hertha Emma (Hattie, 1875-1917); Edward Adolf (1876-1957), and Emil Otto (1878-1946).¹⁰ Baptisms

⁶Schenectady city directories show no Christian Weeber or Christian Weber in the 1860s and 1870s.

⁷See the *Kirchenbuch der Deutschen evangelischen lutherischen Dreieinigkeits-Gemeinde zu Albany, New York* now in the care of Holy Spirit Lutheran Church in Albany. A trunk, H-1986.58.1, in the collections of the New York State Museum, was used "to ship possessions from Germany to Albany, N.Y." Dorothea Ammon's name is painted on the trunk top.

⁸Church records are preserved by the Evangelical Protestant Church at the same site. Happily, the records survived a nineteenth century fire that destroyed the previous building. The Weeber-Ammon wedding, number twelve in the second record book, was wedding number 698 from the first such ceremony at mid-century. While the title page for volume two proved illegible for the author, volume three clearly read *Kirchenbuch der evangelisch. protest. Gemeinde zu Albany, N.Y. Dritter Band*. Caroline Weeber's wedding in 1866 to Wilhelm Schupp was witnessed by Christian Weeber, who also served as witness at the baptism of a Schupp child the next year. Henry Wolfinger is listed in city directories as a cooper.

⁹The birth date, July 5, 1864, predates the marriage of the parents. Church records have no record of the birth. The birth date is recorded in the *Kirchenbuch der Deutschen evangelischen-lutherischen Dreieinigkeits-Gemeinde zu Albany, New York* marking Johann Bernhard Weeber's confirmation on March 25, 1876. His father is shown as Christian Weeber. The German Evangelical Protestant church register does record the birth of a John Weber on July 16, 1864. His parents were Johann Weber and Maria Foell Weber.

¹⁰*Kirchenbuch*. The United States census for 1880 (volume 3, enumeration district 56, sheet 35, line 33) lists the ages for all except Emil; a notation, however, for a two-year old "Amelia" likely refers to Emil. The birthplace for Christian Weeber, Sr., is given as "Wurtemberg;" for his wife "Dora" it is Meiningen. Marion Weeber said her mother's family came from "Colberg Larhsen-Meiningen." Weeber family birth years have been verified by cemetery records. Emil's middle name and birth-

for the two youngest Weeber children were at the Deutsche Evangelische Lutherische Dreieinigkeits Gemeinde (German Evangelical Lutheran Trinity Community). The Weeber family had moved to the new congregation at 58 Alexander Street upon its founding in 1876.

From 1866 into 1868, the Weeber family resided at 104 Nucella Street. By 1869, they had moved to 97 Nucella, also the location of the Weeber meat market.¹¹ At least until the middle of 1878, the family and shop were at 97 Fourth Avenue, as Nucella was renamed.¹² The federal census for 1870 notes that Christian Weeber, a U.S. citizen, owned real estate worth \$6,000 and had a personal estate valued at \$200. In addition to the Weeber family, the building at 97 Nucella Street housed a second family, likely renters.¹³

According to Marion Weeber, her grandparents were not happy in the city. "Grandfather hated the butcher shop and Grandmother hated the saloons on every corner, where most of the men went after work. 'You have to choose between me and the saloon,' she said. We must move."¹⁴

I want to buy a farm [she told him] and I have found this 45 acres, between Schenectady and Albany. It has fertile land, good water, a creek and small pond; and a fine 3-story square brick house with solid walls 12" thick and a cupola. It was built in 1825, has 11 fireplaces, and a floating central staircase. Theres [sic] a black decorative iron gate and a fence at the

day are documented by World War I draft registration data as well as church records. His death date, April 27, 1946, is noted in the Albany city directory for 1946. At age 65, John B. Weeber is listed in the 1930 census as a resident of Yakima, Washington. The April 14, 1930, census listed his profession as a (fruit) farmer. Louis' wife, Mary Niles Weeber, is shown as a widow in the 1920 census.

¹¹City directories in the 1860s and early 1870s in the alphabetical sections list Christian "Weber" rather than "Weeber" at the Nucella addresses. However, in the business section of the 1870 and later directories the "meat stall" at 97 Nucella is shown to be that of Christian Weeber spelled with two ees.

¹²Publication date for the 1878 city directory was June 1, 1878. That volume has the last listing for Christian Weeber, Sr. and his meat business. The first listing for Christian Weeber, Sr., with a correct spelling of his surname, is in the 1875 directory. Emil Weeber was born on January 12, 1878, i.e., before the family left Fourth Avenue.

¹³The renters were Thomas Doyle and his four children, immigrants from Ireland. Father and two sons were printers. One daughter kept house and the other was a school girl.

¹⁴Marion Weeber, October 26, 1990. She rewrote the original transcript by Stein so the quotation marks surround her words.

road entrance, and a tree-lined drive up to the house...Originally owned by Stephen Van Rensselaer who sold it to Almond Birch of Watervliet in 1840. Loudonville has a Schoolhouse for the children. Will you come with us?¹⁵

Weeber, who was “gifted in cabinet making and carpentry,” reportedly protested to his wife that he was not a farmer. She answered by saying they could hire help. “I want to grow only choice vegetables and you can distribute them to the hotels in Troy, Albany and Schenectady, same as you used to with meat.” Marion Weeber claimed they sent to California for seeds and seedlings. In time they reportedly developed “a superior Cantalope [sic]” and “grew a wide variety of beautiful vegetables.” Produce was delivered to customers in a horse-drawn wagon, a son usually accompanying the father on the delivery route.

The United States census for 1880 documents the Weeber family’s move to the rural town of Watervliet. Christian Weeber, Sr. is identified as a farmer and “Dora” as a housewife. The older children, John and Lousia (sic), were “at home.” Louis, Christian and Hattie were in school. Edward and Emil (listed as “Amelia”) were preschoolers.

Christian Weeber, Jr. attended school in Loudonville. On the farm, he learned wood and metal working in a shop his father set up in the carriage house on the farm property, complete with forge and “light machinery” (needed for the repair of Wagons.”¹⁶ Among objects made by the younger Christian Weeber are a frame for a mirror and a marquetry parlor table. In the table, cherry is the primary wood with inlays of maple and walnut. Marion Weeber reported that the wood was cut on the Loudonville farm.¹⁷

Christian Weeber’s childhood incorporated play and work. A turtle shell in the State Museum col-



Figure 1.2: Inlaid parlor table made by Christian F. Weeber, Jr. with wood from his father’s Loudonville farm, 1886. NYSM Collection, H-1986.58.15.

¹⁵Ibid.

¹⁶Chronology prepared by Marion Weeber for the Albany Institute of History and Art, 1996.

¹⁷Marion Weeber, list of objects donated to the New York State Museum, July 10, 1986. Another frame made by the younger Christian Weeber around the same time surrounds a pillow sham. The last, marked with “I awoke and found that life was duty,” was half of a pair of shams dating from the time of Christian and Pauline Paul’s 1904 wedding. The missing sham was marked, “I slept and dreamed that life was beauty.” The framed sham has New York State Museum accession number H-1986.59.8. Marion Weeber provided the history of the shams and frame. See her notes for the Museum dated July 10, 1986.

lection reportedly came in 1880 from a pond on the farm where he swam.¹⁸ He also rode a bicycle, one reportedly he made himself. A group photo of the Weeber family shows Christian holding his high-wheel steed.

On April 18, 1886, Christian Weeber was confirmed in Trinity Evangelical Lutheran Church (“ev. luth. Dreieinigkeits Gemeinde”) in Albany.¹⁹ His confirmation certificate is in German, attesting to the lasting importance of his parent’s native language in their church. Church records of the Weeber family attest to their continued affiliation with Trinity into 1888.

The farm prospered. Visitors were frequent and a church picnic was held there every year. Pauline Paul was among the participants in later years. On Sundays the Weeber family drove in a carriage to Lutheran church services in Albany.²⁰ Hertha also had a saddle horse.

Dorothea shopped in Albany stores “and a dressmaker came out to the farm once a year and stayed for a month, sewing for the women.” Dorothea rented a flat for the winter in Albany so the older children could attend high school.

After Dorothea’s death in 1895, her son Edward married and became farm manager. Christian, Hertha and Emil still resided there²¹ but “that didn’t work out. Hertha persuaded her father to rent or sell the farm and take her on a world tour. Grandfather died while traveling in 1903.” In fact, the farm was sold to Charles L. A. Whitney in 1906 for \$14,000.²²

Of Christian Junior’s siblings, Edward became a coal dealer and contractor in Albany. Louis (or Lewis) operated a butcher shop in Schenectady. Emil worked with Christian in the bicycle business, eventually operating his own shop in Albany. John went to Colorado, laboring in a silver mine and then moving to Washington, where he developed an apple orchard. Louise died at 22

and Hertha, identified by her niece, Marion, as an artist, also died relatively young, at 42 in 1917. “On her death bed, Dorothea had all of her boys pledge never to take a drink and all five of them kept that pledge.”²³

Christian Weeber, Jr. studied engineering at Pratt Institute in Brooklyn and graduated in 1893. According to a 1911 report in *The Albany Argus*, Weeber began work as a designer for the Darling Mailing Machine Company of New York City in 1892. This Darling Company likely utilized the patent (#137,599) for an addressing machine granted to Francis A. Darling of Fayetteville in 1873. However, a review of New York and Brooklyn directories reveals no listings either for a Darling Company or Weeber during this period.²⁴

In 1895, Weeber began a period of employment at the General Electric Company in Schenectady. It was at that time that he “started to design a hydrocarbon engine and shortly afterwards left that company and started the manufacture of automobiles,” said *The Argus*²⁵. It is likely that during his Schenectady sojourn, whatever its dates, that Christian Weeber lived with his brother Louis F. Weeber, who operated a meat market on Schenectady Street.

The newspaper unfortunately omitted mention of Christian Weeber’s bicycle business, which is documented by Albany city directory listings as early as mid-1896, when his shop was at 149 Central Avenue (and his boarding house residence at 308 Sherman Street in Albany).²⁶ A newspaper article from 1909 refers to Weeber having “commenced business at 147 Central Avenue fifteen years ago....” Little survives in the Weeber artifact and documentation collection at the New York State Museum of Christian Weeber’s period in the bicycle trade. In addition to the business card and the photograph reproduced here, there is only a “Clipper Bulletin” dated June 1, 1898, from the

¹⁸Marion Weeber, list of objects donated to the New York State Museum, July 10, 1986.

¹⁹The confirmation certificate was donated to the State Museum by Marion Weeber in 1986, H-1986.58.21.

²⁰At first this was Trinity Lutheran Church at 58 Alexander Street. Sometime after 1887, this was the Church of the Redeemer on Lake Avenue. The picnics likely date from the Church of the Redeemer period only.

²¹The Albany city directory for 1897 shows Christian Weeber boarding on Sherman Street.

²²Marion Weeber, October 26, 1990. In a December 16, 1995, letter, Marion Weeber noted the farm comprised 41 acres.

²³Ibid.

²⁴There was a partnership of Clarissa Darling and Anna Darling on Ann Street. Their business was “mailing.” See New York City directories. The Newark directories have no listings for Francis A. Darling in the early 1890s.

²⁵*The Argus*, February 19, 1911.

²⁶The city directory for 1896, which includes the Weeber listings, was issued about mid-June in 1896. The previous year the business enterprise at 149 Central Avenue had been that of jeweler Ernest H. Miller. In 1896, the upper floors of the building were apartments occupied by Mrs. Mary E. McCollum and Charles H. Settle and their respective boarders.

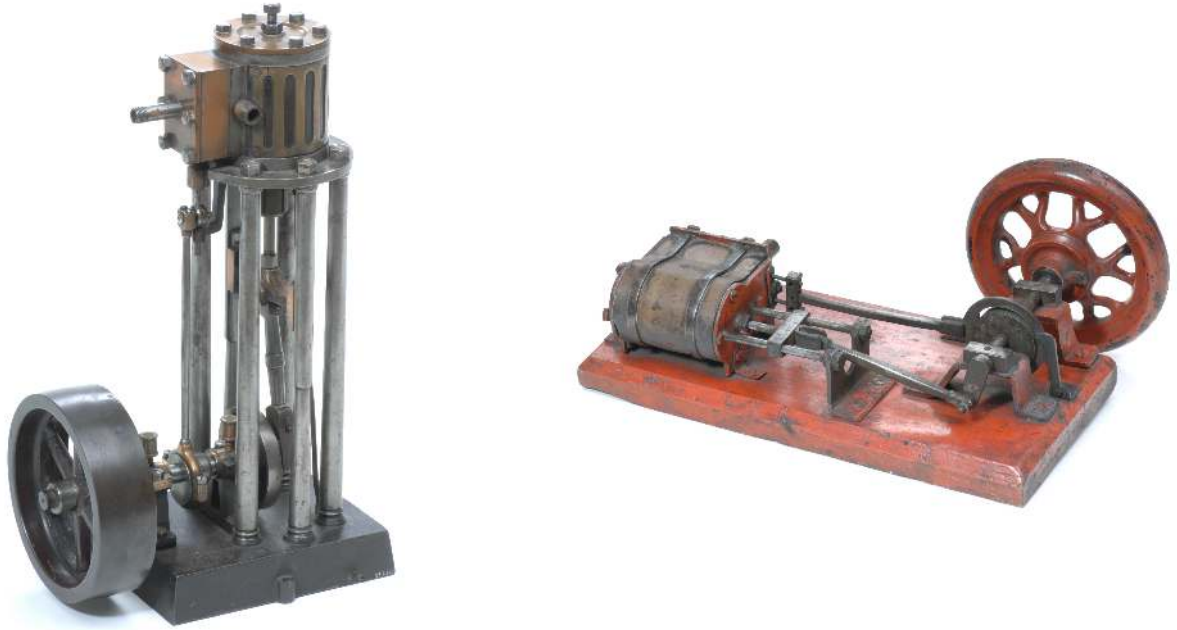

Figure 1.3: Two steam engine models built by Weeber while a student at Pratt. One was displayed at the World's Columbian Exposition in Chicago in 1893 and then exhibited at Pratt in 1932 before being sent to the New York State Museum. NYSM Collection H-1933.6.15 (left) and H-1933.6.31 (right).



Figure 1.4: Christian Weeber in the doorway of his bicycle shop. Brother Emil (who eventually took over the bicycle business) is to the right of the entrance. NYSM Collection H-1970.110.31.

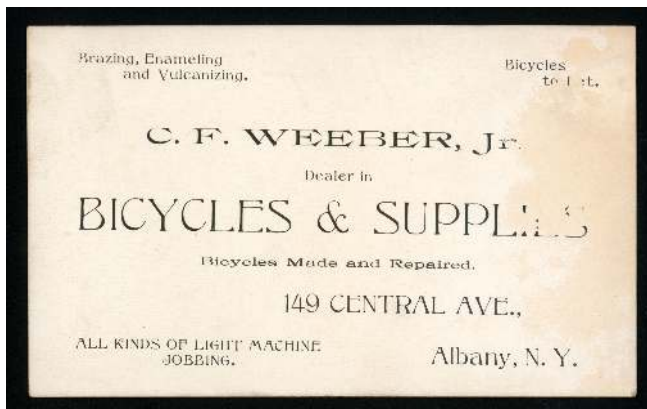

Figure 1.5: Business card for Christian Weeber's bicycle enterprise, dated as 1895. NYSM Collection H-1970.110.34.

Grand Rapids Cycle Company offering “several hundred” 21-inch frames with 1897 Clipper finish to be closed out.²⁷ The photo of his shop shows a combination bicycle rack and sign marked “C. F. Weeber Ide & Clipper Wheels.” Whether Christian Weeber bought any of the left over 1897 Clipper bicycles is not known.

²⁷The brochure continues to add “at a price that will enable you to retail them at above [\$35] price and give you a fair margin of profit.” Designed originally to sell at \$75, these bicycles were to be furnished with “an 1898 name plate.” Grand Rapids also had a “limited quantity of traveler’s [sales representatives] ‘trunk worn’ and sample room slightly ‘shop worn’ ‘98 models” as well as some “odds and ends in ‘97 models... which, if taken just as they are, will be sold at bargain prices.”

CHAPTER 2. MARRIAGE AND FAMILY

Christian F. Weeber, Jr., married Pauline Paul (1876-1962) on June 29, 1904, in a church ceremony followed by a reception at the bride's home at 14 Lexington Avenue. Beginning the same day, a week-long motor trip to Lake George was an excursion Marion Weeber later called Albany's "First Motorized Honeymoon."²⁸ Marion Weeber wrote the following of her parents' early courtship:

In 1902 they met in church—Lutheran Church of the Redeemer on Lake Avenue in Albany. Pauline Paul was a fragile blonde, lingerie buyer at the Geo. B. Adams & Co. department store at 69 N. Pearl St., Albany. Educated in Albany schools, very religious, a lover of poetry, art, the theatre and classical music because of the influence of her pianist brother Theodore. Her hobbies—dancing, sewing, knitting, baking, gardening and bird watching. That year she became an avid cyclist, renting her bicycle weekends at the Weeber Cycle Works. She said Chris gave her special attention and the best bike in the shop.

Every summer the young peoples' society of the church were invited to a picnic at the Weeber farm in Loudonville. This year Pauline went and met his parents, sister and brothers. She told of their great hospitality, and of the sweetest cantaloupes she had ever tasted. (Their commercial crop cultivated for the hotel trade.) She was his first girl and they were an example of contrasts. Chris was too busy for much courtship and very shy, but she went along as he tested his cars and watched his strong muscular arms as he worked at the forge, forming parts for his inventions. He didn't dance, smoke or drink but always brought her a box of candy, and ate most of it during his date. She hung a big calendar in the kitchen. It showed a blacksmith at his forge.²⁹



Figure 2.1: Pauline Paul Weeber, 1904. Photograph the gift of R. Gretchen Weeber and Marion Weeber Welsh, NYSM Collection H-1973.110.4.

²⁸Marion Weeber, "Christian F. Weeber Chronology" prepared for the Albany Institute of History and Art, 1996.

²⁹Marion Weeber, "Account of 1904 Honeymoon Trip with Weebermobile and Other Facts as Told by Pauline to her Daughters," typed manuscript, 1973. Also please note that Christian Weeber's mother, Dorothea, passed away in 1895 so Pauline Paul could not have first met her in 1902.

Marion Weeber also said that on her mother's wedding day she wore a "blonde silk suit with blonde accessories and said she never looked worse in her life, with blonde hair and blonde face, too—ladies didn't wear makeup in those days. They pinched their cheeks and bit their lips for color...

They had reservations at the Worden Hotel in the town of Caldwell on Lake George. They could have made it by evening but two of Chris' brothers jumped on the back seat of the car and vowed they were going along. (They were big heavy fellows.)

Chris drove roughly, in and out of ruts to jounce them off, but they bounced up and down in glee and lost only one of them. Finally, as they passed the little old schoolhouse in Loudonville, the spring on one side of the car broke. Brother Ed consented to get a horse and buggy and to back to the shop in Albany to get parts for the repair.

Pauline sat on the schoolhouse steps while Chris jacked the car up and crawled under it. The moon and the stars were in the sky when the boys finished the repairs. They arrived at Lake George in the early morning.³⁰

Marion Weeber also described the trip in a letter to the author in 1995.

About Albany's first motorized honeymoon, I am sure I told you that as they drove off, Uncle Emil and Ed climbed on the back storage section and bounced up and down claming they were going along. Chris tried to bump them off, putting extra strain on the spring leaves, but they hung on until they reached the little one-room schoolhouse in Loudonville... The brothers then borrowed a horse and wagon and drove back to the bicycle shop in Albany to get new spring leaves and tools.

In the meantime, Chris got under the car to remove the broken one [spring leaf], and got full of grease, while his bride sat on the schoolhouse steps all night, an untouchable vision in her beige traveling outfit. She wore the linen duster with pink pearl buttons, which you [the New York State Museum] have, and a large hat that tied down with a beige veil, and of course she was a blonde. She wore no makeup. She said she looked terrible and felt worse. There must have been photos taken but we never saw



Figure 2.2: Photograph of Pauline Weeber's duster worn on her automobile honeymoon. NYSM Collection, H-1973.110.1-2.

any. She may have destroyed them. They arrived at the Worden Hotel at Lake George in the morning. I have literature and photo of the hotel.

I wrote an account of the honeymoon trip many years ago when I promised you I would, and showed it to my sister, Gretchen, for her approval. She was so distressed that I destroyed it. She was such a quiet, sweet, romantic girl, like Mother, and as she explained she lived in Albany and had to face the amusement.³¹

Returning to Albany, the couple arrived at 272 Western Avenue, a "fully furnished home ready and waiting for them." Marion Weeber noted

³¹Marion Weeber to Geoffrey Stein, December 16, 1995. Albany *Times Union*, January 17, 1999, by Kate Gurnett also wrote an account of the Weeber's honeymoon based on materials in the files at the New York State Museum.

³⁰Marion Weeber, "Account of 1904 Honeymoon..." *op cit*.

that the two-family house belonged to Christian's brother, Emil, who, after receiving an inheritance from his father, bought the property. "[U]ntil he could build a house of his own design," Christian rented from Emil. Marion added that, "Aunt Hertha, the artist, lived with us, and I was born there two years later."³²

Two daughters were born to Christian and Pauline; Marion Gladys Weeber, later Marion Weeber Welsh (1905-2000) and Ruth Gretchen Weeber (1913-1984).

Financial success made possible constructing a new house in 1910 for the Christian Weeber family. The structure at 106 Manning Boulevard is a low, dark building visually dominated by cobblestone work in front and on a porte cochere on the north side.

In 1910 Weeber traded a new Haynes automobile for carpentry work on his house. With the building under construction in late 1909, Christian Weeber also offered to trade a car for electrical work. In a letter dated December 7, 1909, he wrote to James B. Hourigan of Albany on C. F. Weeber Manufacturing Works stationery.

A short while ago you stopped in our place looking for a second hand Ford Roadster and told us to let you know when we had good ones in stock. We wish to state that we now have two newly painted and in good condition that we can offer at reasonable figures. Seeing that you are in the Electrical business wish to say that this writer is building a Bungalo [sic] on Manning Boulevard ahead of Lancaster St. Thought possibly we could make a deal if still interested.³³

While receipts for roofing materials and labor are lacking in the Weeber holdings at the New York State Museum, two letters from John H. Jackson of the New York State Drain Tile and Fire Proofing Works in Albany survive. On November 27, 1909, he mentioned a talk he had with Christian Weeber "about Roofing Tile and you promised to send me a sketch of your roof as soon as you could get it from the Architect." Still waiting for the drawing, Jackson asked for it and mentioned that he could supply plaster, lathe, cement and other materials "as low prices on same as anyone can on an equal grade of goods." Weeber marked the letter "Phone

11/30." A second Jackson letter, from December 4, 1909, notes that the "Detroit people... have quoted a price on this roof... consequently it would be useless for me to figure on this particular job." Nevertheless, Jackson was prepared to quote on plastering materials.³⁴

Christian Weeber's skill at design and metalworking enabled him to provide fixtures for the fireplace in his new house. Among objects now in the State Museum's collections are two cast iron Aladdin lamp-form candle holders and cast andirons with horseshoes. A wooden foundry pattern, carved by Weeber, also is in the museum's collection.³⁵

On the reverse of a list of regulations for exhibitors at the first Albany auto show in 1910, Christian Weeber apparently has written in pencil, perhaps as a calculation for flooring requirements, the dimensions of the rooms of his house.

Spare B R	13 x 11'
R 2x	13[?] x 11
Closets	50 ft.
Hall	4 x 30
Front room	7 x 9
Kitchen	12 x 12
Toilet	5 x 5
Rear hall	6 x 3
Pantry	30 ft.
Office[?]	12 x 12
R [?] hall	10 x 11
Liv R	13 x 14
Library	12 x 15
Dining R	17 x 13

Marion Weeber noted that her father did the cobblestone work on the front porch, porte cochere and chimney. She also wrote, "home designed and built by Christian F. Weeber in 1910."³⁶

As early as December 1909, Pauline Weeber received a letter from the Mason & Hamlin Company of Boston, Massachusetts, inviting her to inspect the Mason and Hamlin pianos for sale "at the warerooms of our Albany representative, Mr. Frank W. Thomas." However, it was in March 1911 that Christian Weeber paid \$100 for a piano from

³⁴Apparently only the first page of the December 4, 1909 letter survives.

³⁵One lamp has inventory number H-1986.58.22; the other is H-2000.39.70. The lamp pattern is H-1986.58.23. The andirons are H-2000.39.7 A-B.

³⁶Marion Weeber's notations appear on the reverse of photographs of the house at 106 Manning Boulevard. See H-1987.39.2-4.

³²Marion Weeber to Geoffrey Stein, December 16, 1995.

³³James Hourigan is listed in the 1908 city directory as an electrician working at 2 William Street.



Figure 2.3: The Christian Weeber family, perhaps in front of the Delmar boarding house where the family spent weekends. Marion appears to be only about two years old and the car is a Model K Ford of the 1907 period. NYSM Collection, H-1995.62.6C.

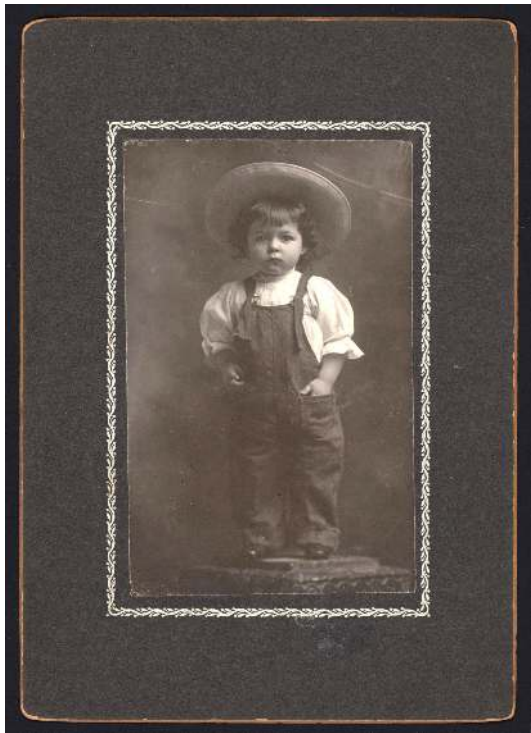

Figure 2.4: The image came unidentified from Marion Weeber's estate. The author suggests this photograph depicts Marion Weeber as a child. NYSM Collection, H-2000.39.118.

Albany makers Boardman & Gray at 543 Broadway.³⁷

Surviving bills for utility expenses at Weeber's Manning Boulevard house include \$3.30 from the Municipal Gas Company of Albany for electricity (33,000 watts) consumed between August 25 and September 25, 1910;³⁸ \$2.80 for 2,800 cubic feet of gas consumed between December 24, 1910 and January 27, 1911;³⁹ and \$12.13 for New York Telephone Company service for March 1911. This last figure combined \$3.50 advance payment for service "as per contract" as well as \$8.63 for "foreign messages."⁴⁰

Christian Weeber had a workbench in the cellar of the house. Marion Weeber recalled a second workbench in the garage, which also contained a pit for servicing the undercarriages of automo-

³⁷The unsigned Mason & Hamlin letter, dated December 3, 1909, has an inside address of "Mrs. C. F. Weeber, Albany, N.Y." The Boardman & Gray receipt is dated March 3, 1911.

³⁸In addition, \$5.10 was past due at the time of the billing, October 1, 1910.

³⁹There was also a past due sum of \$2.60. Weeber marked the bill "Pd. 4/3/11 480."

⁴⁰The document also records \$24.23 for "bill rendered." However, Weeber has subtracted \$24.23, apparently previously paid, and marked this bill "12.12 Pd 4/3/11."



Figure 2.5: Andiron designed by Christian Weeber for his home on Manning Boulevard in Albany. NYSM Collection, H-2000.39.7 A-B.



Figure 2.6: The Weeber house at 106 Manning Boulevard in Albany, c.1915. Marion Weeber wrote the house was designed and built by her father. NYSM Collection, H-1987.39.2.

biles.⁴¹ At the cellar workbench “evenings and weekends, he developed the helicopter models. Here were his best and most personal tools. . .”⁴²

On August 1, 1987, Marion Weeber, accompanied by the author, visited the house on Manning Boulevard. It was the first opportunity she had to see the property since her family had left more than fifty years before. Thanks to the generosity of owners Mr. and Mrs. Lew Millenbach, Marion was pleased to see a residence much as she remembered it. Her father’s cellar workshop, however, was no longer extant.

Life Apart from Work and Family

The 1906 *Albany and Troy Blue Book* lists Christian Weeber and his wife as well as his brother Emil and his wife (Catherine A. Liebel Weeber). Whether a C. F. Weeber Manufacturing Company advertisement in the book influenced the inclusion of the Weeber family members has not been determined.

A surviving German Day (Deutscher Tag) program from 1909 suggests Christian Weeber’s interest in his German heritage and perhaps activities with German-American organizations. A display advertisement for the Weeber firm featuring the Ford Model T occupies half a page in the booklet. Credit for the automobiles provided for a parade includes “C. F. Weber” and Emil Weeber among more than thirty-three individuals and companies.⁴³

⁴¹Marion Weeber to Geoffrey Stein, June 19, 1987.

⁴²Marion Weeber to Geoffrey Stein, March 4, 1987. Of the tools, Marion continued, “after he died, mother gave most of them to her brother John Paul, who was a carpenter and home builder. After his death the tools probably went to his son, John Paul Jr, or his daughter, Mrs. Eleanor Sorrell, both of Albany. After uncle Johns’ [sic] death several years ago, I had thought of asking my cousins, if they would give dads’ [sic] old tools to the N.Y. State collection. I never asked, but if you would be interested I will be glad to write them, and arrange for you to view them.” Apparently, the author never followed Marion’s suggestion. The helicopter project is described in some detail near the end of this book.

⁴³*Deutscher Tag Fest-Programm Albany, N.Y In treuer Freundschaft Sonntag den 15. und Montag den 16. August 1909* (Albany, 1909). Page 69, with information about the automobiles in the parade notes, “Unter den Automobils, die fuer die Parade freudlichst zur Verfuegung gestellt wurden, sind die folgender Herren und Firmen.” The “Weber” and “Weeber” names follow among many others. The Weeber Works display ad, probably alluding to the slow introduction of the T Model, notes that the firm “Can Now Make Prompt Deliveries.”

Marion Weeber noted her father’s friendship with John R. Carnell, Jr., “one of his best friends.” They were similar in age and “neighbors in Loudonville. John was his confidant and helped test some of the automotive improvements on his car.”⁴⁴ In 1908, Carnell had written to Weeber (“Dear Chris”) that he was “[m]uch obliged for your willingness to help me in case I decide to get a machine.” But he, Carnell, had to postpone buying a car “on account of circumstances of health in our family. . . . Sorry to have bothered you.”⁴⁵

Weeber’s friendship with Arthur B. Strough is mentioned later in this work. Apparently, another friend was G. A. White. In December 1907, White wrote Weeber from Hingham, Massachusetts, about the former’s life and family. White, whose salutation was “Dear Chris,” said that it had been a long time since they had communicated with the last letter coming from Weeber. White, who was associated with the Shawmut Manufacturing Company, makers of imitation leathers and embossers on leather and fabrics, wrote that he and his wife liked Hingham. His business was growing. Charley, apparently a son, was in Cuba, where “he likes the country very much.” Ernest in Pittsburgh “says he is doing well. Carrie is attending a business college in Boston. . . .” White and his “better half” were “as happy as happy can be.”

I should like much to see your little girl [Marion] and meet your wife, and have a nice chat with you.

I am anxious to hear how you are getting along in your business if you have any thing new etc. and . . . [illegible. . .] want to see your new building and machine shop so I guess we will try to make it next year.

With many regards to you all and with kind wishes and the compliments of the season I am your friend⁴⁶

Perhaps it was G. A. White’s wife to whom Christian Weeber’s brother John referred as he

⁴⁴Marion Weeber Welsh to Susan Kirkpatrick (New York State Museum), June 17, 1971.

⁴⁵John R. Carnell, Jr. to Christian Weeber, April 11, 1908.

⁴⁶Weeber noted in pencil on White’s letter “on 12/24” (1907). White possibly was George A. White, born in 1855, who is listed as a resident of Plymouth in Hingham, Plymouth County, Massachusetts. His daughter, Carrie V. White, also resided with White and his wife Sophia L. White. White’s occupation is listed as “superintendent” but the words describing what he supervised are illegible on the census form.

wrote from Denver in April 1906. “Mrs. White your friend was at the house one evening.”⁴⁷

In 1909, L.L. Melius wrote to Weeber from Fort Covington on American House Hotel stationery. While the salutation is “My Dear Sir,” and Ludlow L. Melius, a state highway engineer, is identified as a customer as early as 1906 below (see page 58), the text here ends with a closing perhaps suggesting, but certainly not documenting, a relationship something more than a business connection.

The car arrived in Malone last week one day a little late but in good condition I was in dire need of it and can now get back and forth to the work in good shape. Thanking you for any trouble you might have had loading it up and hoping you and your family are enjoying good health. I am.⁴⁸

Irving Posson of Schoharie was another business acquaintance, who, in a 1910 letter regarding the distribution and sale of Ford cars, added a postscript that suggests interaction between his family and Christian Weeber’s, to wit, “My wife & Helen send there [sic] best wishes to Mrs. Weeber & Marion.”⁴⁹

Christian Weeber, as previously noted, grew up in a family affiliated with the Lutheran Church. While Christian Weeber’s German language confirmation certificate from Trinity Evangelical Lutheran Church is dated 1886, his family became associated with a new Lutheran congregation, the Church of the Redeemer, in the late 1880s. According to Henry H. Heins, the new church had its origins “in the winter of 1887-1888 when some fifty young men and women of St. John’s [on Central Avenue] and St. Paul’s [Western Avenue] churches, then exclusively German congregations, sought help in establishing an English-language

church...” It was not a matter of doctrine that prompted this move but “purely a case of language.”⁵⁰

Among the early members was Christian Weeber’s sister, Louisa, who joined in the spring of 1889 shortly before her death from typhoid peritonitis.⁵¹ Holy Redeemer records note that, “At the Holy Communion administered XVI from Trinity [1889], Christian Weeber and Dorothea, his wife, participated.” Three of the younger Christian Weeber’s siblings—Edward (1889), Emil (1893), and Hertha (1904)—were confirmed at the Evangelical Lutheran Church of the Redeemer, as it was known in its early years.⁵² Father Christian Weeber’s death and burial in 1903 were documented in Church of the Redeemer records.

“At the Holy Communion Whitsunday 1890...Christian Weeber, Jr. ... participated.” He took communion again on Easter 1893 and many other times in the years before his marriage. He became a member of the church on June 6, 1897, by “Signing [the] Constitution.” Pauline Paul, his future wife, became a member of the church by Profession of Faith on April 5, 1896.

Christian and Pauline were married at the church on June 29, 1904. Their daughters were baptized by church ministers⁵³ and Marion was confirmed at the Church of the Redeemer in 1920.⁵⁴

While records have no listing for Christian Weeber as a church officer, both Christian and Pauline remained communicants of the Church of the Redeemer from 1905 to 1926, with Christian, accord-

⁵⁰Heins, *Swan of Albany: A History of the Oldest Congregation of the Lutheran Church in America* (Albany: First Lutheran Church, 1976, pp. 131-132).

⁵¹A list of church members shows that Louisa signed the constitution on May 1, 1889. Another record indicates the date was April 14, 1889. She died on May 19.

⁵²Church records, preserved by the First Lutheran Church with which the Church of the Redeemer combined, show Hattie (Hertha) Weeber taking communion on Easter in 1889 and various times following. Emil’s communion record dates from 1900. Edward’s confirmation record notes a gift of \$5 to the church; communion followed between 1894 and 1898. There is also a record of another Edward Weeber confirmation in 1904.

⁵³Church of the Redeemer baptismal records show that Ruth Gretchen Weeber was born at the family home at 106 Manning Boulevard on March 3, 1913, and baptized there on March 23. Sponsors were the parents and Anna M. Keeler, later Anna Keeler Dunspaugh.

⁵⁴Confirmed at the same time, on March 28, 1920, was Alice May Planz, Marion’s cousin, the daughter of Pauline’s sister, Minnie Paul Planz.

⁴⁷John Weeber to Christian Weeber, April 19, 1906.

⁴⁸Melius to C. F. Weeber Mfg. Works, May 16, 1909. The handwritten letter, especially the signature, “H. L. Melius per A. M. M.” [?], is difficult to read.

⁴⁹Posson to “Mr. Weeber”, April 10, 1910. No Irving Posson appears in the 1910 census (although there were many people in Schoharie County with the Posson surname). In the 1920 census, Irvin [sic] Posson, a farmer, is recorded as residing in the town of Wright with his wife, Anetia, and thirteen-year old daughter, Helen, i.e., a girl two years younger than Marion Weeber. Irvin Posson of Wright, a farmer renting property, also is listed in the 1900 census. While he was married then for eight years, his wife was not listed on the census schedule.

ing to church Council Minutes, receiving communion nineteen times in the forty-five times it was offered between 1910 and 1926.⁵⁵ The survival of a prayer book imprinted with Weeber's name perhaps reflects particular interests on his part in certain religious texts. Published in 1919 by the United Lutheran Church in America, the *Common Service Book of the Lutheran Church* has pencil marks at the words for a few psalms and many hymns. One might conclude these marks signify Christian Weeber's affection for the selected passages.⁵⁶

In 1926, the Church of the Redeemer and the First Lutheran Church combined. Christian Weeber's funeral in 1932, noted in Chapter 18, was conducted by Chalmers E. Frontz, minister of First Lutheran, as the joined churches were known.

⁵⁵Peter Christoph, First Lutheran Church archivist, to Geoffrey Stein, November 12, 2007 and November 15, 2007. The Council Minutes for the Church of the Redeemer are held by the First Lutheran Church. Christoph notes, "Communion was offered two or three times a year, and to be a member in good standing you had to receive Communion at least once a year. The Weebers managed to do that." Pauline received communion 24 times in the 1910-1926 period. Marion received communion when she was confirmed and "14 times out of a possible 17, 1920-1924."

⁵⁶The words only, but not the printed music, are included in the volume. The marked hymns have a penciled circle around the identifying number (there being 578 texts altogether). The entire volume, which includes orders of services, bible excerpts and prayers for various occasions, are in English with no German appearing except in a list of translated hymns (mostly German with a few Greek, Latin, Swedish, Danish, French, Italian and Welsh). The prayer book has several flowers (disks) from the money plant pressed between its pages.

CHAPTER 3. AUTOMOBILE BUILDER AND MANUFACTURER; THE SURVIVING WEEBER AUTOMOBILES; WEEBER AS AUTOMOBILIST

The November 25, 1900, issue of *The Horseless Age* noted that “Charles F. Webber [sic], a bicycle dealer of Albany, N.Y., is reported organizing an automobile manufacturing company.”⁵⁷

Portions of at least three automobiles probably built by Christian Weeber have survived. There also is evidence of three Weeber-made automobiles registered for road use in 1905. Exactly how many cars were built by Christian Weeber, however, is not so easily discovered.⁵⁸

In the 1890s news of automotive experiments could be read in journals, such as the *Scientific American*, with which Christian Weeber likely was familiar from as early as his Pratt days. November 1895 issues, for example, had news of a pending automobile race in Chicago as well as illustrations of Kane-Pennington, Duryea, Benz and Electrobat autos. In addition, there was advertising for internal combustion engines. The May 4, 1895, issue, for example, showed four small advertisements for “gas,” “gasoline” and “oil” engines in addition to a “vapor” engine.

By late 1895, the initial issues of *The Horseless Age* (“the first motor vehicle journal in the English language”⁵⁹) introduced a periodical dedicated solely to news of the automobile world, including information about engine and vehicle fabrication and manufacture for a readership interested in self-propelled transportation. Even its first issue had news of well-capitalized builders of engines or complete cars (e.g., William Steinway’s Daimler

Motor Company⁶⁰) as well as rather detailed reports of individuals building their own autos. By 1896, a number of books about internal combustion engines had been published.⁶¹ By September 1898, the *Age* could report that the Haynes-Apperson Company of Kokomo, Indiana, was turning out two vehicles a week (while advertising that fifteen autos were in regular service). “Minor Mention” items noted automobile projects around the country.

Whether Christian Weeber was exposed to *The Horseless Age* or other printed sources encountering information about engines, power transmission, steering systems or body construction has not been determined here. Certainly by 1898 he had absorbed principles and practical information about building automobiles and did not need to create his cars in a knowledge vacuum. By 1899, he was a reader of the *Age*.⁶² Early in the twentieth century he was familiar with, and advertising in, a number of automobile trade journals.

Weeber’s first auto building venture was most likely in 1898. Documentation survives for Weeber’s experimenting with the construction of a “gas engine” in late 1899, but whether for automobile or stationary use is not clear.⁶³ It appears as early as 1900 he was intent upon producing cars commer-

⁶⁰The first issue of *The Horseless Age*, November 1895, described Steinway’s encounter with the Daimler in Germany in 1888 and subsequent organization of this Long Island City factory to build engines and vehicles.

⁶¹*The Horseless Age* for September 1896 listed available and pending titles available from the journal. The list, sometimes with revisions, appeared in later editions of the magazine.

⁶²The first mention of “C.F.W.” in the *Age* is in 1899.

⁶³A letter from “C.F.W.” in Albany to *The Horseless Age*, asks “the lightest that a gas engine cylinder can be made to be safe.” He proposed $\frac{3}{16}$ “on upper half” and $\frac{1}{4}$ in the lower. “R.I.C.” suggested that $\frac{1}{4}$ was minimal for a cast iron cylinder. He suggested steel tubing be used for lightness. See *The Horseless Age*, vol. 5, no. 8, November 22, 1899. Stationary gas engines, manufactured and sold by Christian Weeber, are described in a later chapter of this book.

⁵⁷Volume 7, No. 9, p. 21.

⁵⁸Marion Weeber in 1970 wrote there were altogether three Weeber cars, the first built at the Loudonville farm and the last two “including a two-seater” in her father’s Sherman Street machine shop. Marion Weeber to Geoffrey Stein, August 24, 1970. Of the last car, the “two-seater,” she added, “have photo of car and shop.” The author does not recall seeing such a picture.

⁵⁹So claimed in the March 1899 issue.

cially. At year's end, *The Bicycling World* said, "The C. F. Webber [sic] bicycle works, Albany, N.Y., is the outcome of a retail business conducted by C. F. Webber. [sic] The new concern will engage in the manufacture of bicycles and automobiles on a small scale, a building having been leased for this purpose."⁶⁴

The Cycle Age and Trade Review also took note of the Weeber enterprise: "Albany, N.Y. is congratulating itself on the addition to its industries of a bicycle and automobile factory, to be operated by the C. F. Webber [sic] Bicycle works. The principal says it is his intention to make both forms of vehicles and to make all the parts of his horseless carriages."⁶⁵

Pauline Weeber gave one complete and two partial early Weeber automobiles to the New York State Museum in 1933 and 1935 from Weeber property on Central Avenue in Albany. The most primitive of the three vehicles is incomplete and consists of a chassis, wheels and portions of the body. It may well be from 1898, the year which has been attributed to the construction of the first Weeber-built car. As early as 1908, the C. F. Weeber Manufacturing Works advertised, "We are the pioneers in the auto business in Albany. We built the first complete automobile that dates as far back as 1898."⁶⁶ In 1912, *The Knickerbocker Press* reported that:

Four years after the Hains [sic. Intended was "Haynes", the 1894 auto built by Elwood Haynes in Kokomo, Indiana] machine came out, C. F. Weeber, of Albany, built the first gasoline car that was seen in this city. While Mr. Weeber was working on his car, which he built himself out of materials made by himself, other men in Albany were purchasing the first types of the steam automobile.⁶⁷

⁶⁴November 22, 1900, p. 166. The leased premises were on Sherman Street.

⁶⁵November 29, 1900, p. 110.

⁶⁶*The Argus*, February 2, 1908.

⁶⁷February 11, 1912. The *Press* augmented their article with a photo of a car identified as the Weeber creation. However, unless the Weeber was an exact copy of the 1894 Haynes, the image shows the Haynes car, which the Haynes company displayed widely in its advertising around 1912 with claims that it was the first such vehicle in the United States. Two years earlier the *Sunday Press* (March 6, 1910), said the "first automobile used in this city appeared in 1901 and was owned and operated by Charles M. Page." It was not, however the first machine to be operated under its own power as there were two

In 1917, Weeber was credited by *The Argus* newspaper with "the appearance of the first automobile on the streets of this city." It was, according to Weeber, "minus three cylinders and was seen here during the summer of 1898." It was reportedly built "at the Weeber company plant, which at that time was located on Sherman Street. The work of assembling an automobile in those days was very difficult and the company met delay in securing trained men."⁶⁸

The date and location for the fabrication of the surviving complete Weeber car reported in *The Argus* apparently are contradicted by Albany city directory listings for Christian Weeber. He is shown to be in the bicycle business on Central Avenue from 1898 through 1901. The note in the *Bicycling World* in 1900 to Weeber having leased a building likely refers to the facility at 255 Sherman Street (with Weeber maintaining his Central Avenue shop as his primary business address for a period). The first appearance of the C. F. Weeber Manufacturing Works name and the listing of the facility at 255 Sherman Street are in the 1902 directory. While Weeber's daughter, Marion, maintained that the surviving complete Weeber car was built in 1898, she also noted that its construction had taken place in the shop on the Loudonville farm owned by Christian F. Weeber, Sr.⁶⁹ Perhaps it was the first Weeber car, the most primitive of the three surviving vehicles, that was built at the farm, although complete or partial fabrication at the bicycle shop certainly would have been possible given the tools and equipment available there.

In 1955, the Albany *Knickerbocker News* reported the retirement of seventy-year-old automobile mechanic William G. Berg.

An Albany man who is said to have worked on the first automobile driven in Albany streets... [, he]... went to work in 1900 for Chris Webber [sic] in Central Ave. as a bicycle mechanic and later learned a machinists trade. When automobiles made their debut in Albany, Bill was one of the first to do service work.⁷⁰

'steamers,' or locomobiles, that soon passed out of existence and could hardly be classed as automobiles."

⁶⁸February 18, 1917.

⁶⁹Marion Weeber Welsh to Geoffrey N. Stein, May 30, 1972. Marion Weeber added, "Probably some parts for the car were made at his bicycle repair shop at 147 Central Avenue, Albany."

⁷⁰May 26, 1955.



Figure 3.1: Photograph of the earlier and more primitive of the two incomplete automobiles. If any of the three cars in the Weeber collection was built by Christian Weeber in 1898, it likely would be this vehicle. NYSM Collection, H-1933.6.5.

Unfortunately, the article has no more information about the “first automobile driven in Albany.”



Of the earliest auto, the chassis and portions of the body are separated by four small coil springs. Hard rubber tires are mounted on wire suspension wheels. Steering was done by cable attached to the swiveling front axle. There was gear drive to the live rear axle that lacks a differential but is fitted with a contracting drum brake. Major components missing include the engine, transmission, fuel tank, seat(s) and controls. If this was Christian Weeber’s car of 1898, it was one “which he built himself out of materials made by himself” as “other men in Albany were purchasing the first types of the steam automobile.”⁷¹

The second, also incomplete auto in the State Museum collection, probably was equipped with now missing gasoline engine and transmission. The rear axle would have been driven by a chain. The driven chain wheel remains. The right rear

wheel was powered and the left axle was dead (not powered).

The frame consists of rectangular, channel steel construction. Other components include tubular axles and other undercarriage parts, wire spoke wheels and a finely finished, maroon wooden body. A Raymond band brake mounted on the rear axle is marked with a 1902 patent date.⁷² *The Horseless Age* for February 5, 1902, noted that Charles E. Miller, a distributor of automobile supplies in New York City, held “the selling agency” for the Raymond brake⁷³ so perhaps Christian Weeber purchased the brake from Miller. *The Automobile Review and Automobile News* for May 1902 said Miller had “brought out [a brake] which seems to satisfy all the requirements well.” In its August 15, 1903 issue, the *Review* said the Raymond brake, made by the Royal Equipment Company of Bridgeport, Connecticut, was available in a variety of sizes. “Many automobile manufacturers have adopted this brake as part of their regular machines and

⁷²“The Raymond Brake Pat’d Mar.4.1902” was patented by Arthur H. Raymond of Bridgeport, Connecticut.

⁷³Vol. 9, no. 6.

⁷¹*Knickerbocker Press*, February 11, 1912.

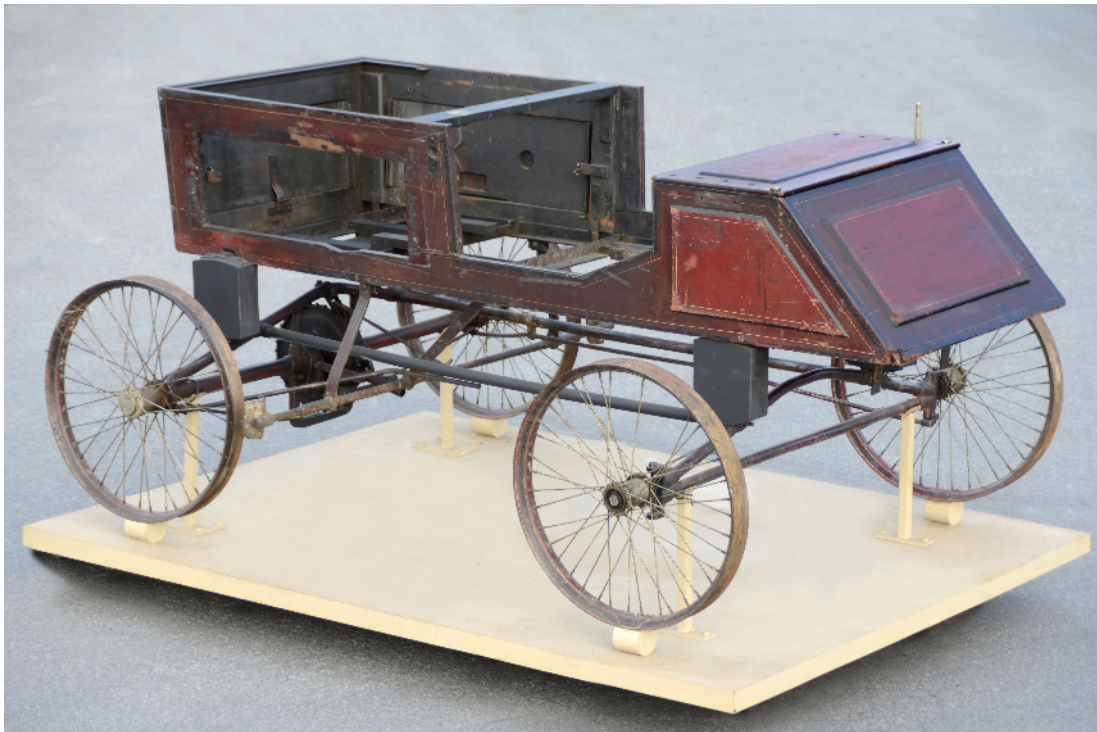

Figure 3.2: Incomplete automobile removed from the facility on Central Avenue after Christian Weeber's death. This likely is a Weeber-built car from about 1902, the patent date appearing on the brake. NYSM Collection, H-1933.6.73 and H-1933.6.108.

they consider it a very valuable factor to the reliability of their cars.”

The body of this second Weeber auto appears to be the product of a carriage or automobile body factory and has affixed to it the label of the Carriage & Wagon Workers International Union.

Perhaps a 1902 Weston-Mott Company (Utica) *Automobile Wheels*⁷⁴ catalogue in the Weeber collections at the New York State Museum suggests the similar but otherwise unmarked wheels on this incomplete Weeber car came from the Weston-Mott firm. Most other automotive catalogues in the Weeber collection are dated a few years later.

In preparing for display in the New York State Museum in 1990, the various parts of this car, probably separate when received by the museum, were united. Some repairs, e.g. gluing of split panels, straightening of a reach and installation of a loose lamp bracket, were undertaken.

Upon learning of the reassembly of the two incomplete cars at the State Museum in 1972, Marion Weeber wrote:

These parts were in the loft of the Central Avenue machine shop, covered with the dust of many years. The wheels were hanging on the brick wall near the beamed ceiling, well out of reach. Dr. Adams [Charles C. Adams, director of the State Museum] selected all of these parts for the Museum. There was nothing in the machine shop that didn't belong to some Weeber invention or prototype.

I often suggested to dad that we should clean the loft out, as we needed space for current material. He said they were models of the early days, early cars he made, and that someday he would put them together again.

I will look through old family albums and am asking my cousin in California to do so too, to see if we can find any record of these cars in use.⁷⁵

The third Weeber vehicle in the NYSM Collection is a complete five-passenger touring car with a wooden body on a channel steel frame. Power is provided by a single-cylinder engine positioned

⁷⁴The catalogue is dated October 1902, H-1933.6.313.

⁷⁵Marion Weeber Welsh to Geoffrey N. Stein, September 22, 1972. Apparently no such documentation was discovered.

horizontally under the floor with the cylinder head aft and the crankshaft forward. The access door to the crank is marked in the casting with the C. F. Weeber Manufacturing Works name as the Weeber stationary engines were marked. The cylinder, unlike the stationary Weeber engines that were water cooled, has many fins to dissipate heat. A belt-driven fan assists in keeping the temperature moderated. The four-stroke engine uses an atmospheric intake valve and a push rod actuated exhaust valve with exhaust gas running to a steel muffler with an external secondary baffle.

A spur gear on the left end of the crankshaft (left being the side of the car to the passengers' left side as they are seated in the car) meshes with a gear on the end of a shaft protruding from a brass, rectangular transmission housing. A flywheel is located on the right end of the crankshaft and a clutch is on the end of the left.

A second shaft in the transmission terminates outside the housing with a chain wheel and a contracting drum brake working on the transmission gears. The roller chain runs to a chain wheel integral to another brake on the rear axle. A third rod in the transmission is shifted from side to side by a series of levers ultimately controlled by a vertical rod outside the front seat and to the driver's right. The progressive shifting pattern provides two forward gears as well as a reverse. The appearance of the gear train suggests all the components were fabricated by Christian Weeber by himself or with help from his employees.⁷⁶

The rear axle has cast components marked "W M CO." The author assumes this is a designation for the Weston-Mott Company of Utica, makers of wheels and axle components in the 1900s. In fact, the wooden artillery wheels in form (including the hub caps) components resemble those in the October 1902 Weston-Mott catalogue received by the New York State Museum in 1933 or 1934 from the

⁷⁶There is in the Weeber collection at the New York State Museum a handbill for the Fort Wayne Gear Company's "Automobile Transmission Gears," H-1933.6.228. This design, as the Weeber transmission, used spur gears sliding on a shaft to engage progressively with gears on a parallel shaft. As with the Weeber transmission, a rod was used to actuate gear changes. While the mechanism is similar to Weeber's, Fort Wayne patent dates as late as August 29, 1905, would argue against use of the system in the surviving Weeber car unless the gears were a replacement for another transmission. The author would think this substitution unlikely.

Christian Weeber estate.⁷⁷ One would think the wheels and axle parts were ordered from Weston-Mott for the car, although the catalogue at hand does not show axles or axle components.

The front axle is steel, square in cross-section. The axle terminates at each end in a yoke for a steering knuckle. Similar items appear in the Weston-Mott catalogue as well as in a Streiby & Foote Company catalogue of drop forgings from 1902. This booklet from the Newark, New Jersey-based Streiby Company also is part of the Weeber collection at the State Museum.⁷⁸

The body of the Weeber car is constructed of wood painted a dark red. Under the front seat cushion is the outline of a decalomania, likely a carriage workers' union label. The other surviving body in the Weeber collection has the union label decal in the same style.

Two bench style seats are upholstered with leather over hair. The upholstered backs are fixed, while the cushions, the rear with a fall, are removable. A panel under the front cushion gives access to the transmission. A similar panel under the rear cushion covers a storage area. A wooden dashboard is fitted with a switch and a coil box. A rectangular housing in front of the dashboard covers a cylindrical brass fuel tank and a dry cell ignition battery.⁷⁹ The body is finished with striping and brass fittings. Two kerosene lamps are attached to the dashboard. A mock, self-

⁷⁷In the catalogue, H-1933.6.313, the artillery wheels are called "the lightest and neatest wood wheels on the market today, having none of that lumber-wagon wheel appearance that most American artillery wheels have." The wheels were available for various weight cars. All show twelve spokes, although their sizes varied among 1," 1 1/8," 1 1/4" and 1 1/2." The Weeber spokes are .8" and 1.1" in diameter at 90°. A memoir by Charles Stewart Mott indicates that Weston-Mott axles were first manufactured in 1902 perhaps attesting thereby to an origin for the Weeber car no earlier than that date. Mott said into 1902, his business was primarily wire wheels. Then the automotive industry turned to artillery wheels and "they wanted to buy front and rear chain drive axles with their wheels... So, we had to design axles of our own—make drawings and blueprints of what we had never produced, and solicit business for a line of goods with which we had no experience." Quoted in Clarence H. Young and William A. Quinn, *Foundation for Living: the Story of Charles Stewart Mott and Flint* (New York: McGraw-Hill Book Company, Inc., 1963), pp. 21-22.

⁷⁸H-1933.6.223.

⁷⁹The dry cells are mock, inoperable items fabricated by the New York State Museum when renovating the car in the 1970s.

generating headlamp is mounted on the front of the battery-fuel tank compartment.⁸⁰ There are no top or side curtains or doors for the car. The driver sat in the right front, using a steering wheel, shift lever, transmission brake lever, carburetor lever, and ignition control pedal.

Marion Weeber maintained that the surviving complete Weeber car was the first of Christian Weeber's cars constructed in 1898 in the barn of his parents' Loudonville farm, where "he had a workbench and forge."⁸¹ While newspaper reports in the later 1910s and 1930 report the date of construction as 1898, it's likely that the car is from the 1903 period. A photograph of the car with Christian and Pauline Weeber in it dressed for a Halloween parade in Albany probably was taken in 1905.⁸² The *Albany Daily Press-Knickerbocker* for November 1, 1905, describes among the 49 cars in the parade one "especially representative of the occasion, the occupants being dressed as witches, and a miniature witch rode on front." The car won the first prize of \$75.

A list of automobile registrants published in August 1902 lists C. F. Weeber, Jr. at 255 Sherman Street. The make of his car, however, is not given. A continuation of that list published in the same issue of *The Horseless Age*⁸³ indicates that the later registrations were recorded from October 1, 1901. Since the earlier list was compiled in twenty-six letter groupings by names in order of registration from the spring of 1901, it's likely that Christian Weeber, being the last of approximately 75 individuals with "w" last names, had registered his car, whatever car that was, in September 1901.⁸⁴

⁸⁰The headlamp is a 1970s recreation of a 1900s Autolyte (brand) style. The non-operating lamp replaces the similar, lost light seen in photos of the Weeber car as operated in the 1900s.

⁸¹Inventory of items donated to the New York State Museum by Marion and Gretchen Weeber in 1970. The accession number is H-1970.110.

⁸²*The Horseless Age*, vol.14, no. 18, November 2, 1904, notes that the Albany Automobile Club had sought car owners in Albany, Schenectady, Troy, Cohoes, Watervliet, Hudson "and vicinity" to enter the Halloween carnival event for which prizes of \$50 and \$25 were offered for the best decorated cars. The *Albany Press Knickerbocker Express*, November 1, 1904, accounts for 56 cars in the Halloween parade. Ten of the vehicle owners are identified. Christian Weeber is not among them.

⁸³August 27, 1902.

⁸⁴For an explanation of the evolution of automobile registrations in New York, see Keith Marvin, "The Dawn of New York State Auto License Plates" in *New York History*, October

Whether this car was the same as any of the surviving Weeber autos is, of course, unclear from the registration lists.

A parade of automobiles in Albany on October 3, 1903 included cars driven by "Chris" Weeber as well as Emil Weeber. The *Times-Union* said it was expected that 40 of the 84 autos in Albany would participate. The *Semi-Weekly Argus* said thousands of people turned out to view the parade. Among the participants was "Dick" Robe, who "rode the first auto ever seen in the city" and who had "done more for the introduction of the automobile in Albany than any other man in the city."⁸⁵

At some point, Christian Weeber gave the surviving automobile to his wife, Pauline Paul Weeber. According to Marion Weeber, Pauline and her sister-in-law, Hertha Weeber:

Wanted to up-date it, make the car more in-vogue, and put the two new side lights on it, and they never changed it back, long after they discontinued driving it. During its early exhibit, its horn and license plates and front lantern were stolen and its upholstery torn. Poor old car!

P.S. [post script] The brass lantern was not attached to front of car when it was acquired by the N.Y. State Museum, but 3 extra lanterns were in the acquisition. These were used to carry where needed, in traveling at night – to light-up for a tire changing or repair, to see a road sign, etc. M.W.⁸⁶

An article in the *Albany Evening Journal* from March 1914 describes the surviving complete Weeber car, identified in the article as the third Weeber auto:

An added and unexpected attraction was put in position on the drill hall floor [at the Albany Auto Show in the Washington Avenue Armory] yesterday afternoon, when C. F. Weeber, a member of the executive committee in charge of the show, procured from B.

1987. Also, New York State Department of Motor Vehicles, "Motor Vehicle and Drive Registration in New York State" (pamphlet: Albany, 1988).

⁸⁵*Times-Union*, September 24, 1903; *Semi-Weekly Argus*, October 7, 1903.

⁸⁶Marion Weeber to Geoffrey Stein, December 16, 1995. She added that, "A photo you have of the Weebermobile with its original 3 brass lanterns for lighting is the photo of the car in the Halloween parade as it started out on Western Avenue (built 1898)."

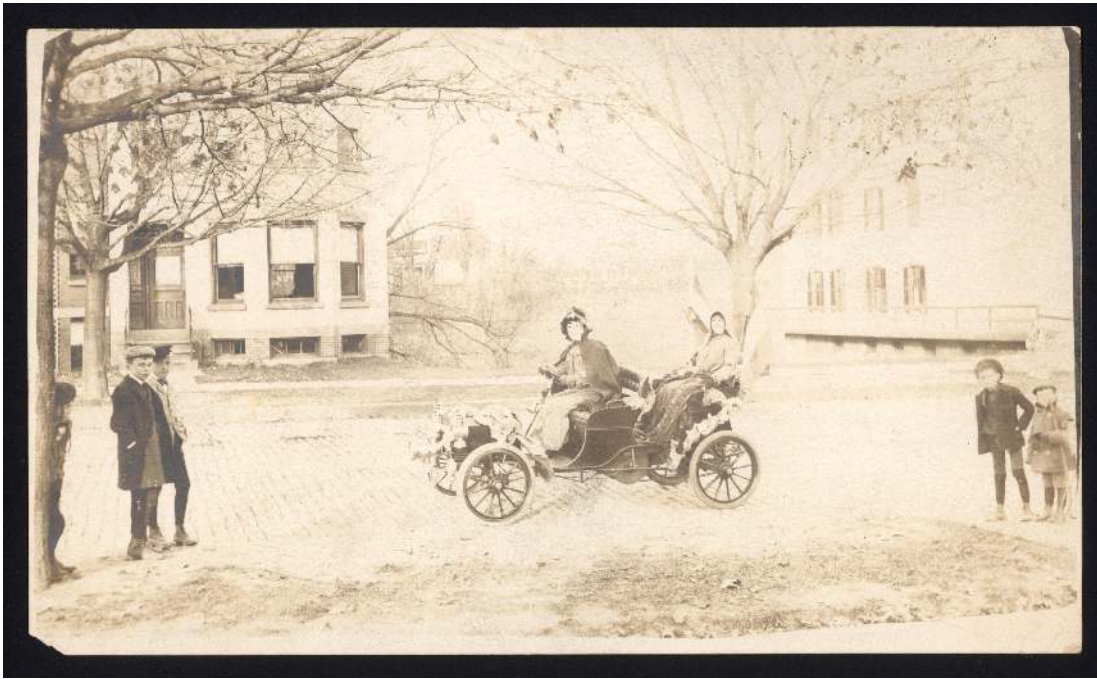

Figure 3.3: Christian and Pauline Weeber in the Weeber automobile decorated for the Albany Halloween parade on Western Avenue in Albany, c. 1905. NYSM Collection, H-1970.110.68.

McNary of Rensselaer, a veteran four-wheeler which has the distinction of being one of the earliest cars in this part of the state still in running order.

The car was constructed by the C. F. Weeber Manufacturing works, builders of Albany's first automobile, and is the third model turned out by that concern. It was built in 1903, and consequently has a record of 11 years of service. It has a side entrance commonly used on all models, although at that time the rear entrance was prevailing. It was pointed out by the concern in those early days that the side entrance would probably be adopted as well as the selective type of sliding transmission. The feature employed operating the clutch and shifting with one lever was somewhat of a novel feature and has always worked well and is still in perfect condition.⁸⁷

The Albany Argus provided additional details of the Weeber car:

Mr. McNary is expectant of using it for several years to come. It is estimated that the "old timer" has run close on to 45,000 miles during its long and faithful service...

The car not only has gone through the length of years in service but has all of its original

parts and it is the owners [sic] intention to keep on using [sic] it for years to come. The car was practically hand made and cost many times the price of a modern car.

The cylinder is air cooled by fins machined from a solid block casting which has proven very satisfactory. The car is not on exhibition to show how well it was built but merely to show the progress in construction to the present day.⁸⁸

McNary likely was Benjamin S. McNary, Jr., a shoemaker who worked and lived with his widowed mother at 95 Washington Avenue in Rensselaer. When he acquired the Weeber auto, and when it left his hands permanently, one assumes to renewed Christian Weeber ownership, has not been established here. One would question the car's utility as a day-to-day automotive conveyance even as early as 1914. In any case, Benjamin S. McNary, Jr. died in January 1919 so if Christian Weeber had not already acquired title to the car from McNary by then, Weeber did from McNary's mother before her death in July 1920.⁸⁹ Weeber apparently had possession of the car as early as two

⁸⁸March 10, 1914.

⁸⁹See Albany city directories, which have separate Rensselaer listings, for death dates. Benjamin McNary died on January 31, 1919; his mother on July 31, 1920.

⁸⁷March 10, 1914.

weeks after McNary's death. *The Albany Argus* reported the following about the 1919 Albany auto show:

One of the most unique, instructive and interesting displays at the Albany Automobile show has been supplied by C. F. Weeber, president of the C. F. Weeber Manufacturing Works at 170 Central Avenue. Nothing at the show so well illustrates the progress of the automobile industry in the last 21 years and it was an inspiration on the part of Mr. Weeber that led to such a novel exhibit. It is at the same time a reminder that pretty fair motor cars were made 20 years ago, although of course they were crude compared to the present day products.

The display consists of all the parts of cars from 1898 to date and a complete car manufactured by this firm out of these same parts. To those who have for years been familiar with automobiles, this car will prove a revelation. Mr. Weeber himself will be at the show this week and there is not doubt that he will be kept busy answering the questions that will be asked regarding his remarkable exhibit.

His exhibit also includes the most modern automobile as exemplified in the Haynes cars, which have established a reputation that extends from one end of the country to the other.⁹⁰

Motor World, in reporting on the 1924 "half million dollar automobile show" in the Washington Avenue Armory, said one of the "interesting exhibits was the first automobile made in Albany and built by the C. F. Weeber Manufacturing Co. in 1902."⁹¹

Of the Weeber-built cars, Weeber's daughter, Gretchen, said in 1963, "When cars were invented, he decided to go into the auto manufacturing business. He built three cars, making all the parts with his own hands. The car which will go on exhibit [at the State Museum] was the first of the three. The other two he sold."⁹²

⁹⁰The *Argus*, February 16, 1919. The newspaper on February 17, 1919, reported that the Weeber exhibit included one of the first Haynes cars in 'striking contrast' to a new twelve-cylinder model. Perhaps the article confused the Weebermobile with the first Haynes car in the Smithsonian Institution since 1910.

⁹¹February 28, 1924, p. 43.

⁹²Patricia Money, "State to Roll Out 1898 Weebermobile," *Knickerbocker News*, August 23, 1963.

Gretchen Weeber told her sister of the appearance of the Weeber car during the Albany "Tercentennial Celebration" in 1930.⁹³ Gretchen remembered seeing the car during two days of parades with the car on a float. She said it was not driven because of the condition of the tires."⁹⁴ Actually, the Albany Tercentenary was celebrated in June 1924 with the parade taking place on June 3.⁹⁵

In 1930, the car received publicity anew as Christian Weeber endeavored to sell the vehicle for \$1,000, according to the *Albany Evening Journal*.⁹⁶ Interest in the car was expressed by Henry Ford, who had a new museum enterprise in Dearborn, Michigan, and financier Julius Rosenwald. The former reportedly said, "Why not give it to my museum? I don't want to pay that much for it?" And the latter said, "The price is too high, [b]ut it would be a fine addition to my museum." Christian Weeber made the following comment as he stroked the car "with affection."

Nothing less than \$1,000. Look, it is very old, yes, very old. One thousand dollars and it is yours. Yes, not only Albany's first automobile but one of the first in the world. Look at it—magnificent with antiquity. Exclusively designed and manufactured here. If you buy it you will have the only car of its kind in the world. It has individuality.

Some forty years later, when commenting on the proposed sale of the car, Marion Weeber observed that in 1930 her father was involved in trying to fund a helicopter enterprise.

Money was very tight at that time, so he apparently tried to raise enough on his own assets. His usual way was to increase mortgages on his property and by bank notes. (He had a line of credit.) He had financed all of the experimental development for all his other inventions on his own.

When he decided to sell the old Weebermobile, I'm sure he thought he could sell it to

⁹³Money, *op cit*.

⁹⁴Marion Weeber Welsh to Geoffrey N. Stein, May 30, 1972.

⁹⁵The *Albany Times-Union* for June 3 and June 4, 1924 as well as *The Knickerbocker Press* for June 4, 1924 have extensive descriptions of the parade but no mention of the Weeber car. The *Albany Evening Journal*, June 3, 1924, also has an extensive report on the parade with mention of "decorated cars" and "sixty floats" but no recognition of the Weeber auto specifically. *Albany's Tercentenary America's Oldest City 1624 1924 Historical Narrative Souvenir* (Albany: The City of Albany, 1924) notes the parade was scheduled for June 3 at 2 p.m.

⁹⁶November 24, 1930.

a collector, so it would have an honorable home. He apparently was interviewed by a news reporter so the facts contained would be fairly accurate, except for a few apparent misquotes.⁹⁷

In describing the surviving Weeber car, which she called the "1898 Weebermobile," Marion Weeber said it was:

Designed lower and longer than other existing cars. Although carriage seats were utilized, the mechanical structure was all specially designed and made by C. F. Weeber, even to cutting the transmission gears. It had many advanced features such as sliding gear and shift transmission. 1 cyl. car, ran 25 mph.⁹⁸

A story associated with the surviving Weeber car claims an initial shortcoming might have made the difference between Detroit and Albany as the center of auto manufacturing in the United States. Weeber was quoted by the *Evening Journal*:

I intended to manufacture automobiles. I had several orders. I started this one in 1898 and finished it soon after. In the trials, its cylinder got red hot. I put the machine back in the shop and left it there. I was disappointed.

One day I had a large shipment of iron coming for my shop. I had no way to deliver it. I went to the barn and gave the crank one turn. The motor started. I said to myself, "You're either going to carry that load of iron up Livingston Avenue hill or I'll wreck you."

I put 1,000 pounds on. It came right up the hill without any trouble. The cylinder did not get hot. What made it heat up on its trials I don't know. But it disappointed me, so I gave up automobile manufacturing.

Subsequently, Weeber drove the vehicle some 50,000 miles including on his honeymoon described elsewhere in this work. Built at a cost of \$750, the five-horsepower machine reached a speed of twenty-five miles per hour. In 1930, the "modern proportioned," one-cylinder "motor block," which was "cut from a solid piece of steel," still "chug[ged] its rhythmical tune with ease."⁹⁹

⁹⁷Marion Weeber Welsh to Geoffrey N. Stein, November 11, 1970. She added that she was not aware of the article "as I was an art student in New York."

⁹⁸Typed inventory of materials donated to the New York State Museum. The accession number is H-1970.110.

⁹⁹*Albany Evening Journal*, November, 24, 1930.

Marion Weeber, in commenting on the *Albany Evening Journal* story, said:

Chris was a perfectionist, and no model is perfect in trial runs. He couldn't expect them to be. The car, no doubt, "went back to the shop when the cylinder got red hot," or the barn, for adjustments and revisions before he could drive it the "50,000 miles" mentioned in another paragraph.

He may have been disappointed many times, and he did procrastinate, but he was never discouraged. He was stubborn in what he believed and had great patience. He really never gave up on anything, but went on altering and improving his designs.

Notice in the article he said he went to the "barn" to get the car out to carry the 1,000 lbs. of iron to the Sherman Street machine shop. The barn was at his parents['] home in Loudonville.¹⁰⁰

The *Evening Journal* article raises the question of the origin of Weeber cars. The story claimed 1898 or "soon after" was the date of construction. On the other hand, the author of the present work, on the basis of the cruder, i.e., likely older, automobile acquired from the Weeber estate as well as the *Albany Evening Journal* article from 1914, believes the car in question is approximately five years younger. One point the reader might keep in mind is that the first city directory listing for the C. F. Weeber Manufacturing Works on Sherman Street is 1902. If the car lay unused until that date, and it had been built in 1898, the auto would have sat untouched for up to four years before starting right up to climb the Livingston Avenue hill. While the 1930 article says Weeber made plans for his car while a student at Pratt Institute, it also reports the "actual manufacturing of this automobile was done at 255 Sherman Street."

When the *Albany Evening News* reported the passing of "Albany's only automobile manufacturer," in 1932, the paper said Weeber had begun experimenting in 1900 "when there were already one or two of the queer contraptions on Albany's streets."

By 1903 he had constructed his first car, a big advance over those being produced at the time. Where other cars used a lever, he had a steering wheel; where other ran with solid

¹⁰⁰Marion Weeber Welsh to Geoffrey N. Stein, November 11, 1970.

rubber tires, his had pneumatic ones, and where others towered feet above the ground, his were low to the ground on the style of modern vehicles. In addition there were seats for five, a good old fashioned claxon, and the crank on the side of the car.¹⁰¹

In writing of Christian Weeber's death, The Albany *Times Union* said "in 1903 he constructed and drove the first automobile through the streets of Albany."¹⁰² The *Knickerbocker Press* said in its obituary that Weeber "constructed and operated the first 'gasoline buggy' to run in the streets of Albany in 1903."¹⁰³ And the *New York Times* said "in 1903 [he] constructed the first automobile to run on Albany streets."¹⁰⁴

In 1950, Chauncey D. Hakes, a pioneer Albanian automobilist, recalled that in 1900 the first four cars in Albany were owned by himself (a Locomobile), Christopher Mathes, Archie Dederick and Henry Klamrath. In 1964, columnist Edgar S. Van Olinda claimed the first car in Albany was a Stanley or White owned by Archland M. Dederick, while Dr. William Milbank was another early automobilist.¹⁰⁵ Francis P. Kimball in his "Story of Albany" series in the *Albany Evening News* in 1934 noted that, "Automobiles first made their appearance in Albany in 1899, among the early owners being Archibald [sic] M. Dederick, Christian F. Weeber and Chauncey D. Hakes."¹⁰⁶

What Did Christian Weeber Make and What Did He Buy in Building the Weeber Cars?

As noted earlier, many components in the surviving Weeber automobiles are the products of outside suppliers, such as the Raymond brake and the body with the union label on the more sophisticated incomplete car. On the surviving com-

plete automobile, the engine obviously is a Weeber product, resembling the stationary engines that he built commercially in the 1900s. Marion Weeber said that her father built the transmission for his car.

A number of catalogues from 1900-1905 received by the New York State Museum from the Weeber estate may suggest sources of parts and equipment that Christian Weeber contemplated using, if he did not use in building his autos. A Streibey & Foote Company (Newark, New Jersey) *Motor and Automobile Forgings* catalogue for 1902, for example, shows a variety of body hangers, pedals, steps, steering knuckles, yokes, rod ends, bell cranks, braces, spring clips and engine parts.¹⁰⁷ A booklet entitled "Automobile Castings" was the product of the William Cramp & Sons Ship and Engine Building Company of Philadelphia. Parts made of manganese bronze and white brass included engine crankcases and transmission housings.¹⁰⁸

A catalogue with a different focus shows the 1904 products for the Salisbury Wheel and Manufacturing Company in Jamestown. Salisbury marketed a variety of artillery (wood) spoke wheels, advertising a capacity of "two hundred perfect wheels per day."¹⁰⁹

While the surviving Weebermobile has wood-spoke wheels, the Weeber collections also include the *Tubular Steel Wheels* catalogue of the American Tubular Wheel Company in Pittsburg [sic], Pennsylvania. With a price list laid in, the booklet likely dates from early 1902.¹¹⁰

Another wheel catalogue is from October 1902 for the Weston-Mott Company of Utica. Both wire and artillery wood wheels as well as wheel parts and steering knuckles are depicted. The catalogue text claimed Weston-Mott was the largest manufacturer of wire wheels in the country.¹¹¹ As indicated above, Christian Weeber did in fact utilize

¹⁰¹September 29, 1932.

¹⁰²September 29, 1932.

¹⁰³September 29, 1932.

¹⁰⁴September 29, 1932.

¹⁰⁵Geoffrey N. Stein to Walter E. Wray, September 15, 1972 refers to August 4, 1950 and August 5, 1964 articles in the *Albany Times Union*.

¹⁰⁶Undated newspaper clip printed "Copyright, 1934." Dederick's given name, assuming there was only one A. M. Dederick, is sometimes listed as "Archland" and sometimes as "Archibald." The 1910 and 1920 census schedules lists Archland Dederick as a farmer in Colonie in 1920.

¹⁰⁷H-1933.6.223.

¹⁰⁸H-1933.6.226. The depiction of a transmission cases for both the United States Long Distance Automobile Company and the Locomobile Company of America suggests a 1903 date for the printing of the Cramp booklet. The Locomobile gasoline car was introduced for 1903, which was the last year for Long Distance.

¹⁰⁹P. 2. H-1933.6. 237

¹¹⁰Among the automobiles shown using Tubular wheels are the Syracuse-built Stearns and Tarrytown-built steam cars. H-1933.6.236.

¹¹¹H-1933.6.313.

Weston-Mott components in building the surviving Weeber cars.

A handbill describes the “Automobile Transmission Gears” made by the Fort Wayne Gear Company,¹¹² the multiple-speed device utilizing spur gears was patented in 1904 and 1905. An undated booklet provides information about the “Warner Spur Equalizer Gear for Automobiles” made by the Warner Differential Gear Company. This differential was “Made in Four Sizes” both for chain and bevel gear drive. A discount sheet gave prices for various quantities ordered at once. “When customers’ aggregate orders entitle them to better prices, we give rebates on all orders of the preceding year, in accordance with the above scale of prices.”¹¹³

A reprint of a September 1906 article in the *Cycle and Automobile Trade Journal* remains among printed materials received by the New York State Museum from the Weeber estate in the 1930s. Hugh Dolnar’s “The Hassler Transmission and Axle”¹¹⁴ describes a combination two-speed transmission and rear axle manufactured by the Marion Motor Car Company of Indianapolis from a design by Robert H. Hassler. Pencil markings on the document read “220.00 less spokes + rims,” perhaps indicating an interest by Christian Weeber in utilizing the device. Dolnar wrote that Marion had fifty units “now under construction, with the expectation of beginning to fill all orders promptly by the first of October next [1906].” One can not be sure that Christian Weeber made the pencil notation nor that “spokes + rims” are precisely the two words that complete the message.

Two copies of the Long Manufacturing Company *Automobile Coolers* catalogue for 1904 and 1905 describe radiators made by the Chicago-based firm.¹¹⁵ While the surviving Weeber car is air-cooled, perhaps Christian Weeber contemplated the much more common water cooling for later cars he planned to build.

In the Weeber collection at the New York State Museum, there is a 1907 booklet promoting the Carrico “air-cooled engine to the trade.” Built by the Speed Changing Pulley Company of Indianapolis, this was a four-cylinder, overhead valve,

20 to 24 horsepower, 375 pound engine. “Prices given on application.”¹¹⁶ A flyer for a Reeves air-cooled automobile engine is undated but probably was distributed about 1908. The product of the Reeves Pulley Company of Columbus, Indiana, the four-cylinder Model E engine was rated 20 horsepower. In the Weeber collection there also is a flyer for the water-cooled Model H engine rated at 22-24 horsepower.¹¹⁷ A brochure for the Lau-Pearson Motor Company (Chicago) Triumph Self-Starting Motor is undated but probably was distributed about 1907. The panel is printed “Model A 30-35 Horse Power” and marked in pencil “450.00.”¹¹⁸ It is not known what use Christian Weeber would have made of any of these engines after giving up production of his own motor vehicles in favor of selling those of other manufacturers. Weeber’s career as an agent for Maxwell, Ford and other makes of cars is discussed in other sections of this work.

In the Weeber collection a *Kinwood Automobile Parts* catalogue for the 1907 season promotes products of the Kinsey Manufacturing Company of Dayton, Ohio, including such parts needed to build automobiles as frames, radiators, hoods, dashboards and fenders.¹¹⁹ Whether Christian Weeber contemplated large-scale manufacture of his own car at that point may be doubtful.

A brochure for the Sintz timer is undated but probably comes from the 1905 period. Prices ranged from \$6.75 for a one-cylinder engine to \$7.50 for a four. Someone, perhaps Christian Weeber, has noted in pencil “ $\frac{1}{3}$ off.”¹²⁰

A price list for Auburn ball bearings, the product of the Auburn Ball Bearing Company in Auburn, New York, is dated July 1, 1903. Whether Christian Weeber planned to utilize, or did use, such bearings in fabricating his cars is not known here. The booklet is marked in pencil “Style U.3” on a page devoted to “Light Thrust Bearings.”¹²¹

A handbill for the “Improved Crandall Mechanical Lubricator” also likely dates from the 1905 pe-

¹¹²H-1933.6.228.

¹¹³H-1933.6.336.

¹¹⁴H-1933.6.316.

¹¹⁵H-1933.6.232 and H-1933.6.254.

¹¹⁶H-1933.6.233.

¹¹⁷H-1933.6.321 and H-1933.6.229. Reeve Bulletins 104 and 107, respectively.

¹¹⁸H-1933.6.333. Kimes, p. 1480, notes the Triumph Motor Car Company organized in 1907 sold the “Self-Starting Car” utilizing a compressed air device.

¹¹⁹H-1933.6.212.

¹²⁰H-1933.6.379. Manufacturer of the “Postive Primary Timer” was Guy L. Sintz in Grand Rapids, Michigan.

¹²¹H-1933.6.355. There is no printed reference to “Style U.3” in the booklet.

riod. The product of the National Sewing Machine Company in Belvidere, Illinois, the pump operated, sight feed device ostensibly was the “very best and most reliable forced sight feed lubricator ever before offered to the trade.”¹²² Whether Christian Weeber purchased any Crandall lubricators is unknown here.

An undated booklet entitled *The Twentieth Century Idea in Spring Work* has laid in a pamphlet depicting “Soft-Edge Automobile and Carriage Cushion Springs” manufactured by the Trenton Spring Mattress Company in Trenton, New Jersey. Also laid in is a price list rubber stamped “Write for Discounts.”¹²³



In the 1970s New York State Museum technician Curtis Fretz repaired the surviving complete Weeber automobile. A number of years later, on December 8, 1989, the late Mr. Fretz told the author in a short record the latter made at that time, “Emil Weeber’s granddaughter claims he had as much to do with building the car as Christian. She lives in Morrisville.”

In January 2008, the author contacted granddaughter Margaret A. Nodell of Morrisville, who wrote she was sorry State Museum personnel had not contacted Emil Weeber’s daughters, her mother Harriet W. Olson and aunt Margaret C. Weeber before their deaths in 1999 and 1990 respectively.

How Many Weeber Cars?

If there is evidence of at least three cars that might be attributed to Christian F. Weeber, Jr., could there have been additional automobiles? A description of a different car, indeed, survives from August 1904. Whether such a vehicle existed in fact or was merely projected is not clear.

The C. F. Weeber Mfg. Co., of Albany, N.Y., is getting ready to manufacture their 8-h.p. air cooled car instead of their 4 ¼ h.p. The engine is of their own design and patent. It has an unusual radiating surface and they claim that it will not run hot. The transmission is of sliding gear type. The motor and transmission are hung together on a 3-point suspen-

sion. It can not roll nor rock on rough roads. The car is built for service and convenience. The rear is flat and packages, boxes, etc., can be carried. The car is strongly built and makes a neat appearance.¹²⁴

Earlier in 1904, C. F. Weeber Manufacturing Works had advertised an eleven-horsepower, two-cylinder Kelcom [sic] engine “in perfect condition; reason for selling, changing to four cylinder high powered motor; first check for \$135 gets it; will fit touring car of French type.”¹²⁵ The advertisement unfortunately does not indicate whether Christian Weeber had removed the engine from a car he had built or another. The Kelecom, a Belgian engine, was imported by A. H. Funke in Manhattan. A 1902 Funke advertisement listed both nine- and eleven-horsepower, water cooled, two-cylinder engines.¹²⁶

In October 1970, the author wrote to Marion Weeber that he had inspected a newly received shipment of materials she and Gretchen Weeber had donated to the New York State Museum. Included in that lot were photographs of three different automobiles all of Weeber manufacture. One car is the surviving complete machine. “The other two cars, one in the Halloween parade and the other at the Louisiana Purchase Exposition, were unknown to me until now.” In asking Marion if the surviving car might date from about 1903 rather than 1898 as she maintained, the author continued:

If the roadster in the parade was manufactured in 1904 [the ostensible date of the parade], and it appears to be of a slightly later style than the tourer we have, the 1903 date seems reasonable to me! The touring car pictured in St. Louis I would guess was also manufactured after the museum car, and appears to be of the same vintage as the roadster.”¹²⁷

A week later, the author wrote Marion Weeber to say he had shown photos of the two cars “to var-

¹²⁴*Automobile Review*, August 20, 1904, p. 185. To what patent the article refers is unknown here.

¹²⁵*Automobile Review*, January 2, 1904, p. 43. The advertisement subsequently appeared in the following three issues of the weekly journal.

¹²⁶*Cycle and Automobile Trade Journal*, October 1, 1902. The same issue of the *Journal* reported that the Kensington Automobile Manufacturing Company of Buffalo had decided to equip all of its gasoline engine powered vehicles with Kelecom engines.

¹²⁷Geoffrey Stein to Marion Weeber Welsh, October 13, 1970.

¹²²H-1933.6.323.

¹²³H-1933.6.360.

ious people here [Albany]. Several of them think that the cars pictured in St. Louis and Albany (the roadster) were probably purchased rather than built on a one-off basis. This seems a more reasonable explanation for two so very different cars constructed in 1904.”

The author continued by stating a view he subsequently changed.

The more I think about the car we have here [the complete automobile], the more I think it could well have been built in 1898. The evidence for the date is consistent reference to it in museum correspondence and artifacts. The only evidence against it is internal, i.e., the car’s mode of construction. Considering your father’s inventive mind, I would think there was no need for his car to resemble others built at the time.¹²⁸

Three and a half decades later, the writer is inclined to date the surviving car from the 1903 period as indicated above by the *Albany Evening Journal* article from 1914 stating this was Weeber’s third car, one built in 1903.

At the time of this writing, October 2007, the photos of the Halloween parade and the Louisiana Exposition are not available.

A list of automobile registration numbers published in 1905¹²⁹ documents three cars with a Weeber brand name. The vehicle with the lowest registration number, 827, is reported as owned by C. F. Weeber, Jr., at 255 Sherman Street in Albany.¹³⁰ William W. Bell has noted that the 954 owners who registered autos in 1901 later (in 1903) received numbers 1 through 954 to replace the initials used earlier as identification on their license plates.¹³¹ This would confirm the first Christian Weeber registration in 1901.

The other early Weeber auto registrations include numbers 2225 (1903) for a Weeber car assigned to “E. Weeber” of 229 Ontario Street; 8249

¹²⁸Geoffrey Stein to Marion Weeber Welsh, October 30, 1970.

¹²⁹Hall Publishing Company, *New York Official Automobile Register and Tourists’ Guide Nineteen Hundred Five* (New York, unknown date around 1905). A 1904 list also includes two Christian Weeber and one Emil Weeber-owned cars with the same registration numbers as the 1905 publication, but the earlier list does not give the makes of those cars. See The Star Company, *Motor Book* (Motor: New York, 1904).

¹³⁰The 1904 list gives the owner’s name as C. T. Webber, Jr.

¹³¹Bell to author, e-mail, May 19, 2006.

(1903) for an Orient car registered by “C. A. Weeber” of 255 Sherman Street; and 11719 (1904) for a Weeber registered by “C. A. Weeber” of 255 Sherman Street.¹³²

In 1975, the author inspected an automobile chassis equipped with two Weeber mufflers. He wrote to Marion Weeber:

The only other identification are manufacturer’s [sic] names on oilers and petcocks. I would guess that it is not one of your father’s cars. It is water-cooled while the Weeber engines we have are air-cooled. The technology is very much steam engine oriented although it is a two cylinder internal combustion engine. Except for the muffler, nothing looks Weeber to me.

The car has been in Rotterdam for thirty years that the owner knows. He has had the car only a short time but hopes to make it runnable. I’m very much excited at discovering it. Does it look familiar to you?¹³³

In June 1975, the author wrote to the owner of the car fitted with Weeber mufflers, Earl D. Benzal, to see if he might divulge the name of the previous owner of the automobile. Apparently Benzal did not reply. The author wrote that Marion Weeber “has some information on Weeber muffler sales, and would like to know the name of the man who owned your car before you did.”¹³⁴

Marion Weeber wrote to the author in November 1970 in response to him sending her a 1930 article that mentioned the fabrication of a single Weeber car. Marion Weeber replied:

¹³²Hall Publishing Company, *The New York Official Automobile Register and Tourists’ Guide Nineteen Hundred Five* (New York, n.d.). Among the registration medallions (issued beginning in 1903 with registration numbers) in the Weeber collection at the New York State Museum is one with the number 11720 (accession number H-1933.6.19D). Advertisements for the Lucey-Taylor Automobile Company in the 1904 and 1905 Albany city directories show that among the cars sold was the simple Orient Buckboard; other makes available were Winton, Cadillac, Franklin, and Toledo as well as “French and German Cars.”

¹³³Geoffrey Stein to Marion Weeber, May 19, 1975. Photos were enclosed with the letter. Actually the stationary engines in the Weeber collection at the State Museum are water-cooled; the author was in error in 1975.

¹³⁴Geoffrey Stein to Earl D. Benzal, June 8, 1975. Apparently the author sent some photos of the Benzal car to Marion Weeber for possible identification.

The way this is written gives the impression that he only built the one car, which is not correct. This is the car he kept for himself and drove. This first car was “one of a kind” as the following models were altered with improvements. He told me he built several custom made models for local customers. I’m trying to find record of their names. I know one of them was a cripple and special equipment was devised to enable him to operate the car. Being custom built, too, may account for the different appearance of the models.

Chris gave up making the Weebermobile because he couldn’t compete with the big factory made cars, so in 1900 decided to concentrate on manufacturing his inventions of improved automotive parts—the “Weeber Specialties.”¹³⁵

As early as 1902, “C. F. Weeber, Jr.” was listed in the *Business Directory and Merchants Register of Albany—Troy* as “mfrs. Automobiles, Motors & Parts” at 255 Sherman Street.¹³⁶ Lists of automobile manufacturers in the January 1903 issue of the *Cycle and Automobile Trade Journal* include the C. F. Weeber Manufacturing Works at 255 Sherman Street under the “Miscellaneous” category (contrasted with gasoline, steam and electric types).¹³⁷ What was meant by miscellaneous is unclear to the writer. Several makers of ordinary gasoline or steam cars are included in the list. Perhaps since some of these companies also built motorcycles, e.g., E. R. Thomas Motor Company of Buffalo, or only motorcycles, e.g. the Industrial Machine Company of Syracuse, these factors suggested to the journal that the miscellaneous category was appropriate.

As late as the spring of 1906, Christian Weeber’s brother, John, thought of Weeber automobile production as continuing. Writing from Denver on the letterhead of the Jacob Dold Packing Company of Wichita, John asked:

Dear Chris,

In making autos, do you ship them for sale to different points if so Denver & vicinity is about the Market in this country.

¹³⁵Marion Weeber Welsh to Geoffrey N. Stein, November 11, 1970. The article appeared in the *Albany Evening Journal*, November 24, 1930.

¹³⁶P. 50. Weeber’s Cycle Works are listed as Emil Weeber’s business at 147 Central Avenue.

¹³⁷P. 260. Lists of automobile manufacturers published in the April 1903, p. 106 and April 1904, p. 108, issues of the *Journal* do not include the Weeber firm

Having now no retail business & some time on my hand I know of no other business paying as well as the Auto now & if you have a good machine to send this Market, have no doubt that it could be sold at a good profit. Hoping to hear for you on this I remain Your Brother John¹³⁸

By 1909, the *Albany Times Union* could report that, “For some time, Mr. Weeber manufactured automobiles, motors and parts but so great has the demand for some of his special devices become, that all of the efforts of the factory are now devoted to their manufacture.” Yet the automobile industry, apparently as late as 1910, continued to consider Christian Weeber an automobile manufacturer. In February and March, the Gier and Dail Manufacturing Company wrote to the Weeber Manufacturing Works three times to ask about supplying gears for Weeber cars. “We would like to have your blueprints and specifications for steering gears, especially on 1911 Models.”¹³⁹

By this time, however, Christian Weeber, in addition to manufacturing specialized car parts, also was a successful agent for cars made by others. In transition from fabricator to distributor, Weeber mirrored a general movement from manufacture of one or a few cars by an individual for himself or for sale to a centralization of manufacture by a few large-scale builders. As early as March 1907, *The Horseless Age* had observed that the “custom of building cars for their own use from stock parts or from parts of their own design was quite prevalent” three or four years earlier. At that time “quite an extensive business” was done in parts for assembling cars “by several supply houses.” As

¹³⁸John Weeber to Christian Weeber, April 19, 1906.

¹³⁹B. S. Gier, general manager, to C. F. Wheeler [sic] Mfg. Works, March 8, 1910. The earlier Gier letters are dated February 11 and 18, 1910. The Gold Coin Stove Company of Troy also solicited Weeber’s business in this period for gray iron castings – “soft, smooth, clean casting, which is bound to please the most exacting buyer.” James N. Bussey, secretary, to C. F. Weeber, January 7, 1910. An earlier Bussey letter is dated December 20, 1909. Two years earlier, the W. E. Caldwell Company of Louisville, Kentucky, makers of “power transmission machinery,” wrote the Weeber Works to ask for the specifications for “Cast Iron Fly Wheels finished or rough, also Friction Clutch Pulleys for Gas and Gasoline Engines.” While the flywheels might have had automotive application, the pulleys likely were intended for stationary engines, which, as will be seen below, Christian Weeber manufactured. A. B. Miller, secretary for the Caldwell Company, to C. F. Weeber Mfg. Wks., March 30, 1908.

has been noted, Christian Weeber himself utilized parts made by others in building his cars.

In 1907, second-hand cars supplied the wants of many seeking inexpensive cars. In addition:

The range of prices for stock cars has been extended considerably in the lower direction, and the impression formerly prevailing that there was an enormous manufacturer's profit even in low priced cars had been dispelled. The construction of individual machines is justified only as long as an industry is still in an unsettled state, and this stage has now been passed by the automobile industry.¹⁴⁰

Other Weeber Artifacts at the New York State Museum

In addition to the single complete and two incomplete autos given to the State Museum, Pauline Weeber donated a number of other objects from the Weeber shop on Central Avenue. Among them were parts of automobiles, such as headlights and other lamps, horns, wheels, name plates, spark plugs, driving chain and seats. There also are related objects that are not actually parts of automobiles: license plates and "Hudson Fulton Celebrations Flags used in Parade on Weebermobile," photographs, drawings of Weeber mufflers, 162 printing plates (electrotypes, et al.), circulars and catalogues, letterheads and stationary gasoline engines. In an inventory list, Marion Weeber noted:

Also—Nov. 1935 2 [model steam] Engines made by Christian F. Weeber, while a student at Pratt Institute, School of Science & Technology, Brooklyn, N.Y. 1891-93[.] Forwarded from Pratt, where they had a memorial exhibit at the entrance to their Mechanical Engineering Laboratory. In glass case, for one year.¹⁴¹

¹⁴⁰March 10, 1907. Vol. 19, no. 12.

¹⁴¹Copies of this inventory are located in the files of the State Museum. Notations on the inventory at the museum were made in 1970, indicating its existence then. That was the year in which museum personnel renewed contact with the Weeber sisters, probably the first time there had been communication with the Weeber family since the 1930s, i.e., it's likely the typed inventory was done by Marion Weeber in the 1930s. A lack of museum catalogue numbers on the inventory other than some letters and digits used by Marion Weeber also argues for an early creation of the list. While the inventory lists only one stationary gasoline engine, there are two in the museum's collection. A copy of a letter without the sender's

The story of the Museum's acquisition of Christian Weeber artifacts is explored further in Chapter Seventeen.

Christian Weeber as an Automobilst

One assumes Christian Weeber drove automobiles from 1898, the date of construction of his first car. And his final driver's license, issued only a few months before his death, indicates that he continued to operate cars into 1932.

What style of driving Weeber undertook, whether relaxed or aggressive, slow or more likely quick, is unknown here. Marion Weeber wrote, "I don't believe Chris ever had a driving accident. He ran into the 'Weebermobile' himself years later when it was stored in our home garage. I believe he bumped into the back of it."¹⁴²

One surmises that Christian Weeber enjoyed driving, for he undertook adventurous challenges at least in the first decade of the twentieth century. In 1906, he participated in the Albany Automobile Club's endurance run to Boston and back. In August 1906, he and his wife contemplated a tour of northern New York and "the Eastern States" in a Maxwell automobile.¹⁴³ Subsequently, "Mr. and Mrs. Charles [sic] F. Weeber, Jr., left yesterday in their Maxwell car for a test tour through northern New York. They will return after Labor Day."¹⁴⁴ Marion Weeber later recalled that she accompanied her parents on that trip.

Writing of her parents' friends, Arthur B. and Mary Strough, she said, "They had a second home

address from S. S. Edmunds, presumably at Pratt, to Pauline Weeber, dated March 19, 1934, notes in reply to a letter from her that "we have had great pleasure in exhibiting your two engine models during the past year, and we are ready now to return them as planned." Edmunds agreed to ship the models to the New York State Museum. And he proposed to recondition the two objects. "This we will gladly do if it meets with your approval. One of the models needs minor repairs, and each of them needs a general cleaning, polishing and painting."

¹⁴²Marion Weeber to Geoffrey Stein, April 19, 1990. She continued, "That is my only memory of the car, jacked up with a canvas drop cloth. I was a baby when I rode in it, and mother held an umbrella over me in bad weather. She wore the usual duster and veiled hat."

¹⁴³*The Argus*, August 26, 1906.

¹⁴⁴*Ibid.* September 2, 1906. The *Argus* also noted that "Mr. and Mrs. Emil Weeber and Mr. and Mrs. Walter Van Wely, who have been making a tour of the Berkshires in Mr. Weeber's Corbin car, have returned to the city."

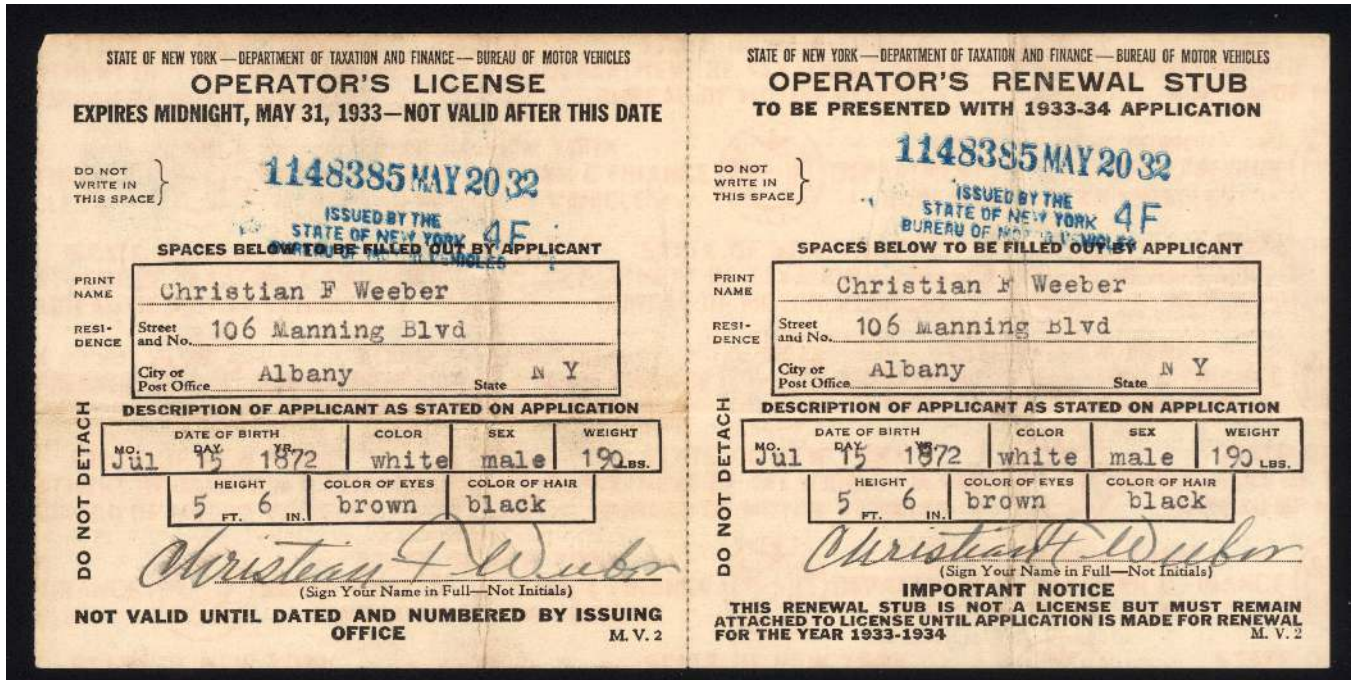

Figure 3.4: Christian Weeber's final driver's license. NYSM Collection, H-1996.31.5.



Figure 3.5: Automobilst Christian Weeber (extreme right) in duster and cap; Pauline Weeber (standing at extreme right); Christian's sister Hertha (standing second from left); brother Lewis (bow tie and cap); and brother Emil (cap at center right) gathered with family and friends at Lewis' Saratoga home, 1904. NYSM Collection, H-1973.110.3.

in the Thousand Islands and we drove up there. I was photographed there on a big rock near a waterfall when I was 2 years old."¹⁴⁵ Another time she wrote that:

Chris became interested in the environment in about 1906. His friend Arthur B. Strough...was in the N.Y. State Dept. of Conservation. They drove throughout northern N.Y. State in the old car, examining the streams, lakes, and general condition of forests and vegetation."¹⁴⁶

In April 1908, "C. F. Weeber and party" joined a group of Albanian and Trojan automobilists in driving to Westchester County to view the Briar-cliff road races.

They arrived at the grand stand between 3 and 4 o'clock on the morning of the race, having driven their cars to the course through muddy ways though the roads were good. When they turned in at the grand stand to see the lay of the land they had no intention of planting themselves there for the day and taking root in Westchester county. But when they attempted to "move on" they couldn't budge. The cars were stuck in the mud up to the wheel-hubs....

Which is how it happened that the Albanians saw all that was worth seeing of the Briar-cliff race from an incomparably fine vantage point.

The reason the Albany contingent is not still planted firmly in Westchester county, waiting for wings to sprout or the mud to dry out, is that after races they went forth and procured jacks and jacked the cars up so they could be finally on solid ground and could turn their steering gear Albany-ward.¹⁴⁷

In May 1908, as recounted below, Christian Weeber won first place in his class for light cars in the first, and only, Menands Hill Climb. Strough photographed Weeber as he negotiated the hill.

In July 1908, the American Automobile Association's fifth annual reliability tour passed through Albany. A copy of the route book, heavily stamped with the C. F. Weeber Manufacturing Works name

¹⁴⁵Marion Weeber to Geoffrey Stein, April 14, 1990. The New York State *Red Book* for 1905 shows A. B. Strough as a special agent of the Fisheries, Game and Forest Commission at Clayton. He was appointed on May 29, 1895. In Albany, the Stroughs lived at 187 Quail Street.

¹⁴⁶Marion Weeber to Geoffrey Stein, April 4, 1990.

¹⁴⁷The *Argus*, April 26, 1908.

and address, survives in the Weeber collection at the New York State Museum. Much thumbed and marked by hand "Please do not..." and "For reference only," the booklet is evidence of great interest in its content.¹⁴⁸ What connection Christian Weeber had with the reliability tour is unknown here.

Weeber was a member of the Albany Automobile Club. In the summer of 1907, *The Argus* said the 150 member club was "one of the most active in this State in forwarding of good roads reform, in safeguarding automobilists' interests and in stimulating automobile enterprise." Many of the members were socially prominent and involved with the automobile business. Fellow members included Weeber's business associates Fletcher Battershall and Willard Sutherland.¹⁴⁹ An automobile badge (H-1970.110.3) from the Weeber collection shows that the Albany Auto Club was associated with both the New York State Automobile Association and the American Automobile Association. In October 1907, *The Argus* noted that C. W. "Weeber" among other Albanians was "planning to go to the next meeting of the American Automobile Association, October 31, to November 8, in New York city."¹⁵⁰

¹⁴⁸American Automobile Association, *Official Book of the Fifth Annual Reliability Touring Contest* (Buffalo, 1908). New York State Museum catalogue number H-1933.6.185. The Weeber collection also has a United States Automobile Company *Western New York Tour Book* for 1907. This was the second edition of the tour book published by the Rochester automobile dealership. Whether Christian Weeber made use of the suggested routes among western New York cities and villages is unknown here. H-1933.6.322.

¹⁴⁹*The Argus*, July 28, 1907, published a list of club members with their street addresses in Albany or other residence location, e.g., Cohoes, Troy, Menands. In a few instances business associations are listed instead of addresses. Two women were club members. *The Horseless Age*, October 9, 1901, vol. 8, no. 28, announced the organization of the club. Weeber was not among the twenty-five charter members that included Chauncey D. Hakes and Archibald [Archland] M. Dederick.

¹⁵⁰October 20, 1907. The paper reported, also, "The circulars relating to reduced railroad fare for the convention has been received by Albany automobilists." Interestingly, in October 1910 the Albany Automobile Club withdrew from the New York State Automobile Association. While \$1 of Albany Club dues had been forwarded to the State Association for dues there and for the American Automobile Association, the Albany Club decided by vote that the state organization was lax in fighting for motorists' rights, often leaving the battles to be fought by the Albany club. A letter of explanation for the decision to withdraw has Christian Weeber's characteristic pencil checkmark on it, indicating that he read the document.

In addition to the \$5 annual Albany Auto Club dues, on July 15, 1907, Weeber paid five dollars “to be used by the Club [to fund a road patrol] to protect motorists from [speed] traps.”¹⁵¹ On June 4, 1909, club member James C. Fitzgerald of the J. B. Lyon [Publishing] Company wrote to Christian Weeber stating that “more cars than are already promised for Orphan’s Day” were needed and that while generosity of Albany automobile owners already had been “overtaxed... these children however must be taken care and we promise that this is positively the last call this year.” Weeber noted in pencil that he would “write or phone” regarding the orphans’ outing.

Pauline Paul’s brother, Theodore (1882-1917), a piano player, tuner and dealer in the 1910s, operated a movie theatre in Delmar. Marion Weeber recalled her father “enjoyed the early Charlie Chaplin films. I remember he said he wished he could do those things with his cars.”¹⁵² Marion later added, “We stayed over at the [Delmar] boarding house because it was so late at night and we were all tired. Chris preferred to drive on those hazardous dirt roads with deep ruts in daylight. Frightened horses caused many accidents. We all had to be back at work in Albany on Monday morning and I had to go to school.”¹⁵³

Among items in the Weeber collection at the New York State Museum are a published list of registrants of motor vehicles in New York State for 1914; a pamphlet containing the “Motor Vehicle Law of the State of New York” published in 1916

¹⁵¹*The Argus*, August 4, 1907, lists the initial contributors to the fund. Of the 35 donations, 19 were for \$5 and all were listed as coming from individuals, of course, including Weeber. The Rensselaer Hotel in Troy gave \$50. The Albany Garage Company, the Troy Carriage Works, and the Troy Auto Exchange were among eight \$25 donors. Receipts for Weeber’s club dues from May 1 through November 1, 1908 survive in the collections of the State Museum.

¹⁵²Marion Weeber to John L. Scherer at the New York State Museum, December 31, 1986. Marion Weeber noted that Theodore Paul died in 1917 and that the “Delmar area did not support the theatre sufficiently and it operated at a loss.”

¹⁵³Marion Weeber to Geoffrey Stein, September 14, 1995. On August 29, 1995, Marion wrote to Stein and John L. Scherer at the State Museum that Theodore Paul lived on Quail Street in Albany. “We often drove Uncle Theodore and Aunt Dorothy out for the weekend. We all stayed over at a boarding house, and returned Monday morning. My father enjoyed the Charlie Chaplin movies so much. Theodore had a Delmar friend operate the theatre during the week.” She also noted that Theodore Paul operated the theatre from 1914 to 1917, when he died.

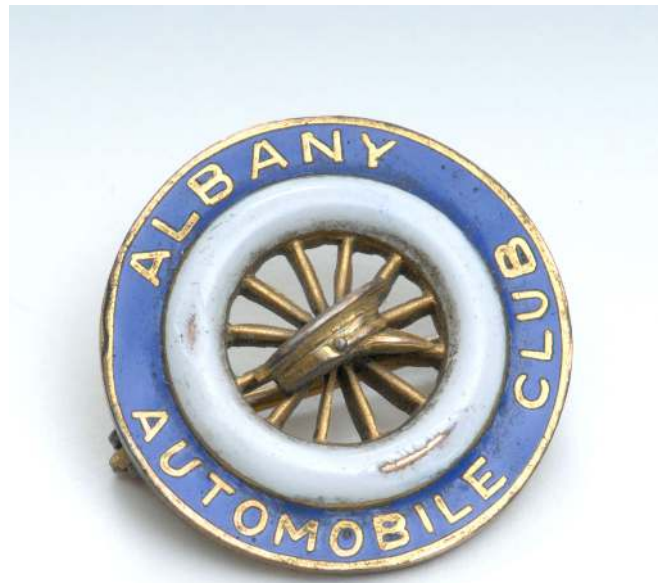

Figure 3.6: Christian Weeber’s Albany Automobile Club lapel pin. NYSM Collection, H-1970.110.1.

by the secretary of state; and a “Statewide Emergency Road Service Mid-Winter Edition 1927” booklet published by the New York State Auto Association listing garages providing service to motorists.¹⁵⁴

¹⁵⁴Two copies of the registrant list for 1914 are H-1933.6.197 and H-2000.39.102. The vehicle law pamphlet is H-1933.6.319. The garage list (“Service given only when car is on the road and does not include lifting cars out of ditches”) is H-1933.6.390.

CHAPTER 4. INVENTIONS AND PRODUCTS TO 1910

Engines

In the 1900s, the Weeber Manufacturing Works built one-cylinder, vertical, water-cooled, four-cycle internal combustion engines as stationary power plants. For sites where piped gas was available but not electricity, such engines were useful substitutes for steam engines or water turbines to run machinery or even to generate electricity for local use. Where gas was not available, such stationary engines could run on carbureted gasoline.¹⁵⁵ As electricity from centralized power companies displaced gas for illuminating purposes in urban areas, the same current simultaneously provided power for electric motors. By the 1910s, the utility of internal combustion engines such as the Weeber, greatly diminished.

A letter from "C.F.W." in Albany, New York, dated November 2, 1899, was printed in the November 22, 1899, issue of *The Horseless Age*. In his communication, Christian Weeber asked the journal about the needed weight of a cylinder casting for a "gas engine" as well as the "explosion pressures per square inch under regular high pressure engines." The letter mentions Weeber's use of a "brass water jacket, calked over" in the engine he was making. The Weeber stationary engines were, in fact, water cooled, while the engine in the surviving complete Weeber automobile is air cooled. Weeber's letter does not mention what the described engine was used for. While the magazine's name suggests that the material contained within it pertains only to motor vehicles, one might conclude that the expert's advice would be as appropriate for stationary engines as for mobile ones.

For the benefit of readers, the complete exchange is reproduced here. Weeber's respondent, "R.I.C.," was identified on the masthead of *The Horseless*

¹⁵⁵An advertisement in *The Horseless Age*, vol. 6, no. 11, June 13, 1900, placed by C. L. Jones of Ridgewood, New Jersey, described a two horsepower "Gasoline or gas motor for experimental or shop purposes." His engine was "piped for gasoline but will also use gas." Complete with "electric sparker," coil, batteries, piping and gasoline tank, the price was \$50.

Age as "R. Clegg," "mechanical editor." The author assumes this was Robert Ingham Clegg (1866-1931).¹⁵⁶

Albany, N.Y. Nov. 2

Editor, *The Horseless Age*:

What is the lightest that a gas engine cylinder can be made to be safe? I am making a cylinder 4 x 3¾ in.; the wall, of gray iron, is 5/16-in. thick on upper half and ¼-in. at the lower, and has a brass water jacket, calked over. Is this heavy enough, or can it be lightened? Please give explosion pressures per square inch under regular high pressure engines.

C.F.W.

1. We would not advise a cast iron cylinder of that size being any less than ¼-in. Where lightness is the main object sought, would suggest a section of steel tubing for cylinder shell.

2. Highest pressure we have known in practice was 300 lbs. You will find tables of tests, etc., in the text books by Clerk, Donkin and others.

R.I.C.

The March 22, 1905, issue of the trade journal *The Horseless Age* noted receipt from the C. F. Wee-

¹⁵⁶The full name and dates have been taken from the Library of Congress catalogue. Clegg may have lived in Providence, Rhode Island, in the later 1890s, when Robert I. Clegg, a machinist, appears in the city directories. In the 1910 period Robert I. Clegg was editor of *Castings: A Journal of the Art of Founding*. *The Horseless Age* in vol. 8, no. 37, December 11, 1901, published a letter from "R" in Albany dated December 2, 1901, in which the writer asks about "foreign built motors—thickness of cylinder shell, thickness of surrounding water space and metal employed. Would a cylinder wall of cast iron 3/16-in. thick be too light for a motor of 4½-inch bore, water jacketed?" The writer, unidentified here, also asks about the use of tubular connecting rods. The answers provided by the editor in effect approve the 3/16-in. figure (giving dimensions for two French and one German engines) and advise against the tubular rod. Earlier, in the December 12, 1900, vol. 7, no. 11, issue, the *The Horseless Age* printed the text of a letter from "R" asking if there would be more wear in a four-cylinder, horizontal engine (as "A. contends") versus a vertical arrangement (as "B. says").

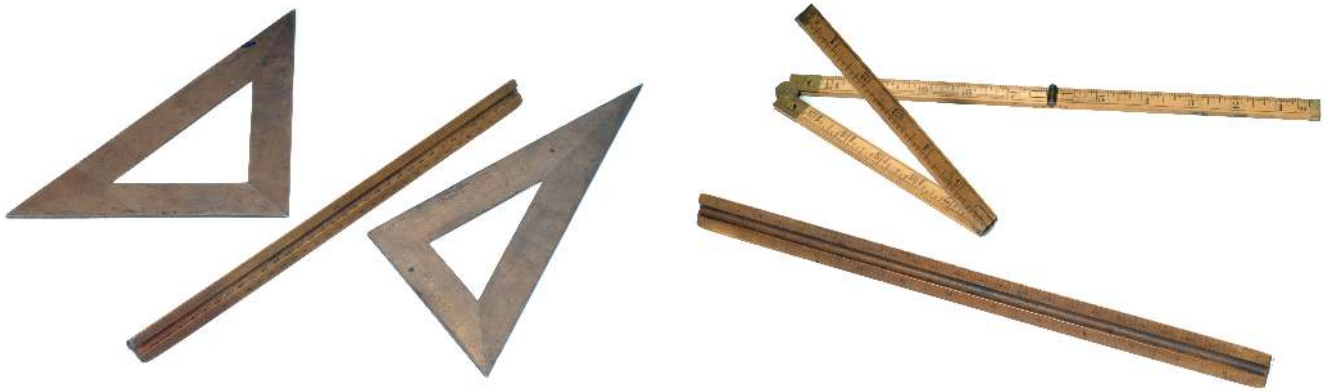
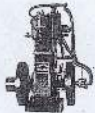
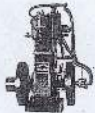
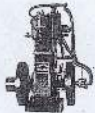

Figure 4.1: Christian Weeber's drawing tools, some of which date from his student days at Pratt Institute. NYSM Collection, H-1986.58.2-10 and H-1975.74.40-44.

ADVERTISING DEPARTMENT. 923

STOP AT THE
TAYLOR AUTOMOBILE CO., Inc.
 SALE, STORAGE AND REPAIR STATION,
 AGENTS FOR THE
Locomobile,
 33 AND 35 ORANGE STREET,
 TWO BLOCKS FROM CENTRAL DEPOT AND HOTELS, ALBANY, N. Y.
 Jos. B. Taylor, Treas. & Gen'l Manager. H. R. Tel. 1157
 Official Blue Book Station.

<p>Chas. F. Schifferdecker, WHOLESALE AND RETAIL ICE DEALER. Office No. 1 Third Avenue, ALBANY, N. Y. PETER CLASS, - - Manager. HOTELS and FAMILIES SUPPLIED. Both Telephones 874.</p>	<p>C. F. Weeber M'g Works. MANUFACTURERS OF Automobiles, Motors and Parts, 255 Sherman Street, Tel. Connection. ALBANY, N. Y.</p> <p style="text-align: center;">WEEBER GAS AND GASOLENE ENGINES FOR ELECTRIC LIGHTING AND ALL POWER PURPOSES.</p> <table style="width: 100%; border: none;"> <tr> <td style="width: 33%; border: none;">WORKMANSHIP:</td> <td style="width: 33%; border: none; text-align: center;"></td> <td style="width: 33%; border: none; text-align: right;">PRICE PER H. P.</td> </tr> <tr> <td style="border: none; text-align: center;">THE HIGHEST</td> <td style="border: none;"></td> <td style="border: none; text-align: right;">THE LOWEST</td> </tr> </table> <p>The kind that will run smooth and keep running. Not an experiment, but tested out by four years continuous running. Guaranteed for one year and to give absolute satisfaction.</p>	WORKMANSHIP:		PRICE PER H. P.	THE HIGHEST		THE LOWEST
WORKMANSHIP:		PRICE PER H. P.					
THE HIGHEST		THE LOWEST					

**S. J. DAVENPORT & CO.,
 CONTRACTORS,**
 And BOARDING STABLE, 218 and 219 First Street.
 ASPHALT WALKS AND CONCRETE PAVEMENTS,
 HERMETICALLY SEALED FLOORS.
 ALSO
 Planting and Guaranteeing Growing Shade Trees
 From 5 to 14 inches in diameter, by Hall's Patent Process.
 Also STREET SPRINKLING and SWEEPING.
 Office, 16 Tweddle Building.

Telephone Connection

Figure 4.2: Display advertisement for Weeber engines in Albany city directory, 1905, p. 923. New York State Library, Manuscripts and Special Collections.

ber Manufacturing Works at 255 Sherman Street in Albany, "Circulars showing Weber [sic] gasoline engines."¹⁵⁷ A display advertisement in the 1905 Albany city directory indicates that Weeber gas and gasoline engines had been in use for four years. Claimed to be suitable for electric lighting and "All Power Purposes," the engines, Weeber suggested, were the "kind that will run smooth and keep running." They were guaranteed for one year "to give absolute satisfaction." Within one year, a Weeber engine would be providing power to the new building for the C. F. Weeber Manufacturing Works.

An invoice from the Detroit Lubricator Company in April 1907 documents the sale of two "gas engine oilers," twelve other oilers and twenty-four grease cups to the C. F. Weeber Manufacturing Works.¹⁵⁸ The previous month the Weeber firm purchased two #6 automatic oilers from the Motor Car Equipment Company of New York City.¹⁵⁹ Whether the purchase of any of these oilers indicates the continuing manufacture of Weeber stationary engines is unknown here.

A catalogue in the Weeber collection at the New York State Museum presents the 1903 equipment for Apple Igniters, the products of the Dayton Elec-

¹⁵⁷Vol. 15, no. 12, p. 373.

¹⁵⁸The gas engine oilers were models #26 and #27, which listed for \$6.50 and \$9 respectively (both discounted 80% and then an additional 5%). Shipment was via the Michigan Central and New York Central railroads.

¹⁵⁹The Motor Car Equipment invoice notes shipment of six oilers at \$7.50 each. The document is marked in pencil, likely by Christian Weeber, "order calls for only 2 oilers. bal. returned."



Figure 4.3: Two Weeber stationary engines survive in the New York State Museum. The absence of a carburetor indicates the example ran on piped gas received from a central supply. NYSM Collection, H-1933.6.120 and H-1933.6.6.

trical Manufacturing Company. Included are generators, governors, batteries, coils, spark plugs and switches for outfitting stationary, automotive and marine engines.¹⁶⁰ Whether Christian Weeber utilized this ignition system on his stationary engines or on his automobiles or both is unknown here. A Baker & Company, Inc., (Newark, New Jersey) catalogue from January 1904 shows “Sparking Points for Stationary, Marine and Automobile Gas [sic] Gasoline and Oil Engines.”¹⁶¹ Pencil notations on the cover and soiling suggest at least a casual look at the booklet and its platinum-based products.

Two identical handbills for the Orr gas engine starter, the product of the Orr Gas Engine Starter Company of Omaha, suggest that Christian Weeber—at a minimum—investigated the device. Three patents for engine starters were granted to Francis L. Orr of Turman, Iowa, in 1906 and 1907. One of those patents, likely the one covering advertised starting device, was assigned to the Orr Engine Starter Company in Omaha. It utilized

¹⁶⁰H-1933.6.389. There is also a Dayton Ignition Apparatus catalogue for 1912, H-1933.6.300, showing similar equipment from the same company nine years later.

¹⁶¹H-1933.6.346.

compressed gas, actually a portion of the engine exhaust gas, to power the starter. Whether Weeber purchased examples of the starter for his own use or for sale with his stationary engines is unknown here.¹⁶²

Catalogues in the Weeber collection at the New York State Museum for marine goods in the later 1900s perhaps suggest Christian Weeber had an interest in boat engines. A 1907 publication of the Ferro Machine and Foundry Company, *Marine Gasoline Engines*,¹⁶³ in particular points to at least a casual interest in such motors. A smaller Ferro pamphlet has some pencil notations possibly in Weeber’s hand.¹⁶⁴

¹⁶²A drawing of the “starting valve” on the handbill suggests that compressed air was the medium used by the Orr device. This image does not appear in the patent drawings. The assigned starter patent is 837,953. The other Francis Orr starter patents are 809,211 and 870,580. The earliest patent (i.e., lowest numbered) design utilizes electricity to fire the engine as well as compressed air to turn it over.

¹⁶³The subtitle is *Being a Treatise on Marine Engines in General and the Ferro Marine Engine in Particular* (Self-published: Cleveland, 1907).

¹⁶⁴H-1933.6.331. “2 Cyl 7 HP 3 [Cyl] 10 1/2 [HP] Included.” This smaller catalogue has been pierced possibly for hanging on a nail.

Muffler

The earliest patented automotive device that Christian Weeber manufactured and marketed was a muffler advertised (“It Does the Work”) as early as 1902. The patent itself, number 692,094, is dated June 28, 1902. Weeber’s idea was “allowing a gradual expansion of the exhaust so as to maintain a steady uniform pressure and prevent any noise, such as usually occurs with an engine or motor of this class when not provided with my muffler.”¹⁶⁵

The muffler itself consisted of a canister containing two series of small tubes. Exhaust gas from the engine flowed through a pipe into the muffler and then into half of the smaller tubes, which turned 180 degrees toward the engine. Reaching the engine end of the canister, the gas exited the small tubes, reversed direction after hitting the end of the canister, flowed towards the far end, reversed direction again and entered a second series of small tubes. Once more making a 180 degree turn, the gas flowed into a second pipe and exited the muffler.

While an undated clipping from an unidentified Albany newspaper in 1909 says that the building at 170-172 Central Avenue was where “the Weeber shock reliever muffler and other auto devices are made,”¹⁶⁶ at least some of the manufacture of the Weeber muffler in previous years was contracted to outside agencies as documented by surviving bills and receipts. J. A. Becker (“Pattern Shop”) in Albany turned out a muffler pattern for \$2.25 on September 21, 1906.¹⁶⁷

¹⁶⁵The patent application was filed on September 7, 1901. Weeber’s patent attorneys were Ward and Cameron, i.e., Walter E. Ward and Frederick W. Cameron, who had offices in the Albany County Bank building.

¹⁶⁶The clipping was sent to the State Museum by Marion Weeber on May 23, 1983.

¹⁶⁷Becker also billed for “auto patterns” of unspecified types made on July 17 and November 2, 1906 as well as patterns in March 1907. He billed for 12.5 hours’ work on carburetor patterns in late 1907. It is unknown here what Weeber project utilized carburetors in this 1907 period. A handbill (H-1933.6.249) in the Weeber collection at the New York State Museum shows “Shain’s Ball Spray Carburetor, the patented product of Charles D. Shain, Auto-Specialist” at 70 Murray Street in New York City. The reverse of the flyer has a fine cutaway drawing of the Shain device. There also is a booklet printed in 1906 or after about the Heath Dry-Gas Company \$25 to \$50 “Carbureters [sic] That Carburet.” “Demonstra-

M. [Mina] Sommer “Dealer in Hardware, Stoves, Tinware &c.” at 311 Central Avenue, billed for the making of mufflers at fifty cents per hour in May, October and December 1906; May, June, July, September, October and (as many as 40 mufflers produced in eight hours on the last day of) November 1907; March, April and May 1909, when fifty mufflers were turned out on April 21 alone. A surviving Sommer bill for “Mr. Weeber” dated June 1, 1909, for “Bill Rendered” of \$13.75 is apparently marked in blue pencil by Christian Weeber, “Paid 6/21/09 M Sommer, Per P. Bentz [name illegible] Ch.”¹⁶⁸ A Sommer business card notes she, as successor to Edward Kinzel, was a “practical sheet metal worker in all branches” with “hot air heating, a specialty.” Actually, it’s likely P. Conrad Sommer, rather than Mina Sommer, was the sheet metal worker; Albany city directories for 1906 through 1909 list Mina Sommer as a dealer in “stoves, etc.” and P. Conrad Sommer as a tinsmith. Both worked and resided at 311 Central Avenue.

Apparently the J. M. Warren & Company of Troy shipped the steel for making mufflers directly to Sommer while billing the Weeber firm. On September 7, 1907, Warren was charged for two bundles of 20 x 28 “Woods Cleaned Sheet,” 327 pounds at a cost of \$.0325 per pound, for a total of \$10.63 plus \$.49 likely for shipping on the “Electric” railway between Troy and Albany. Ten days before Warren had sent two bundles of “Warrens Cleaned Sheets” for \$10.76 plus \$.50 freight prepaid, although the invoice does not mention Sommer. On April 20, 1909, Warren charged the C. F. Weeber Mfg. Co. for a “Bdl #20 x 30” x 9... [illegible?]... Iron” at a cost of \$3.97 to be delivered freight collect to “M. Summers Central Ave., Albany NY.”¹⁶⁹ On July 18, 1909, the Warren Company shipped another bundle of “#20 x 30” x 96” Com Iron,” 153 pounds, to M. Sommers [sic] at 211 [sic] Central Avenue in Albany. Again the charge was to the C. F. Weeber Mfg Co.; \$3.98 for the iron plus \$.25 freight for delivery via “Elect.”

George H. Thacher & Co. (Albany Car Wheel Works) billed C. F. Weeber for 557 pounds of cast-

tions at 1623 Broadway, New York, On Our Cars or Yours.” H-1933.6. 334.

¹⁶⁸A search of census records and city directories in 1909 failed to locate a “P. Bentz,” although there were other Albany residents with the Bentz surname.

¹⁶⁹Shipping was via “Elec Ex,” one assumes electric streetcar. The Warren bill was paid on June 15, 1909.

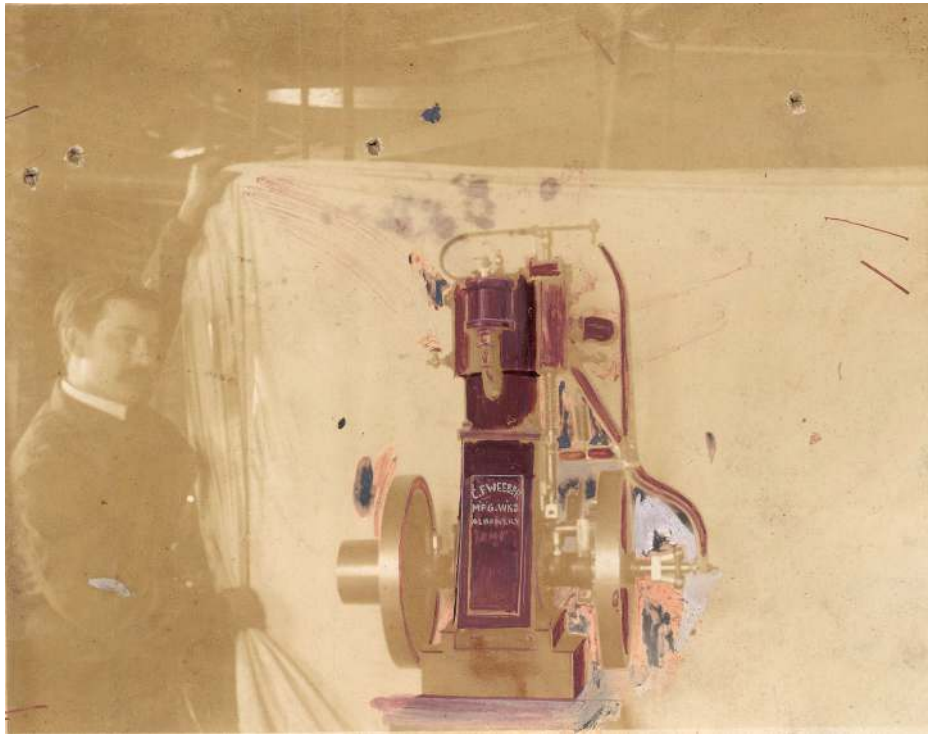

Figure 4.4: Photograph of a Weeber engine for publicity purposes. NYSM Collection, H-1933.6.116.

ings at five cents each on August 20, 1907; 31 muffler castings at five cents each on September 20, 1907; and “62 Mufflers 370#” at five cents each on September 24, 1907. Marion Weeber also has noted, “Clarks Foundry made the castings of the Weeber Muffler (in the tri-city area).”¹⁷⁰

The Aird-Don Company, dealers in pipe and plumbing supplies in Troy, sold the C. F. Weeber Manufacturing Works 3,000 1/8 x 9” nipples on October 17, 1906. The author assumes these were to be used in the manufacture of mufflers, specifically the gas inlet and outlet piping. The charge for the nipples on December 11, 1906, was \$2 per hundred or \$60 plus \$.25 each for two barrels.

One of Weeber’s best muffler customers was the Electric Vehicle Company, later the Columbia Motor Car Company, of Hartford, Connecticut. Ironically both electric and gasoline cars were being manufactured as Electric Vehicle ordered 100 mufflers on November 1, 1904.¹⁷¹ A second order followed on January 4, 1905, for 100 mufflers with “Delivery to begin March 1st, as called

for.”¹⁷² At least one more order followed before August; an Electric Vehicle letter on August 6 in reply to a note from Weeber mentions “105 mufflers still due on our order #49902...”¹⁷³ Also in August 1906, the *Argus* reported that, the Weeber firm was “shipping its patented muffler for 1907 cars. All Columbias and other prominent cars are using the Weeber muffler, an Albany product.”¹⁷⁴

An Electric Vehicle order on September 18, 1906, for 100 mufflers patterned after blueprint 4447 may have followed an earlier order for 50 of the same pattern. Two days later T.R. Higgins wrote:

Replying to your letter of September 14th regarding our order for fifty Mark 48 [a Columbia car model] mufflers, blue print B-4447—we note that it will be necessary for you to make up new patterns and jigs for getting out these mufflers, and that on this account there will be an increase in price. We wish you to proceed with this work, and

¹⁷⁰Marion Weeber to Geoffrey Stein, February 6, 1979.

¹⁷¹Electric Vehicle Company order number 39428 to the C. F. Weeber Manufacturing Works. The mufflers were to fit a 1½” pipe.

¹⁷²Order number 41495.

¹⁷³T. R. Higgins, assistant purchasing agent, to C. F. Weeber Mfg. Co., August 6, 1906. Higgins asked for shipment of 25 mufflers on August 15, 25 on September 1 and 55 on September 15.

¹⁷⁴August 19, 1906.

No. 692,094.

Patented Jan. 28, 1902.

C. F. WEEBER,
MUFFLER FOR EXPLOSIVE ENGINES.

(Application filed Sept. 7, 1901.)

(No Model.)

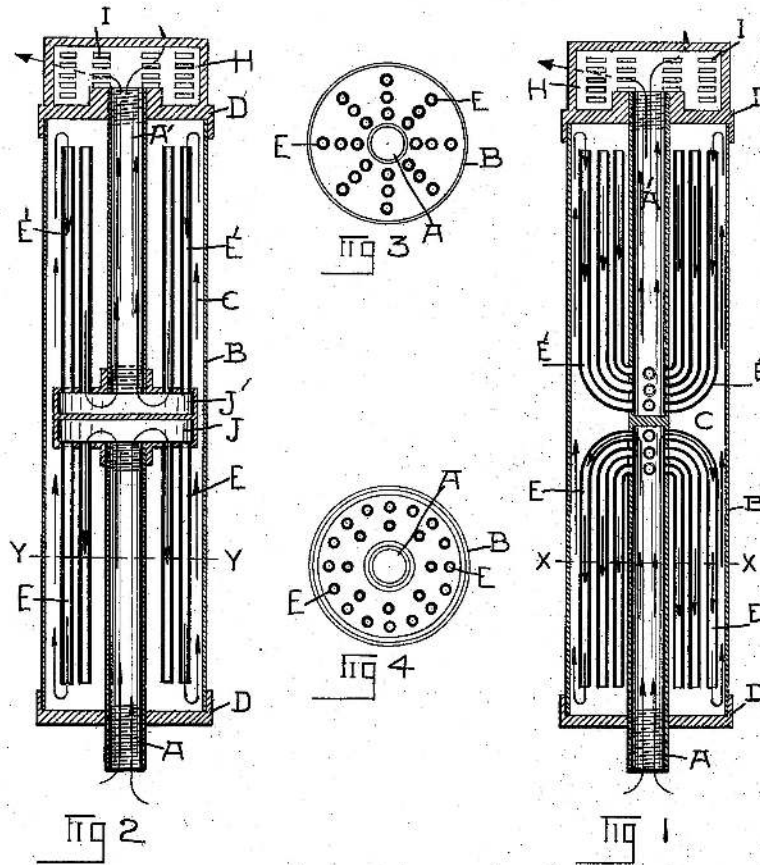

WITNESSES
Lottie Prior
Frank Reid

INVENTOR
Christian F. Weeber
BY *his* ATTORNEYS *Ward & Cannon*

THE MORRIS PERCHER CO., PHOTOGRAPHERS, WASHINGTON, D. C.

Figure 4.5: Patent illustration of Weeber muffler (#692,094). Courtesy of <http://www.uspto.gov> United States Patent Office.

would ask that you keep the cost down as low as possible.¹⁷⁵

Another document of Weeber's muffler business with the Electric Vehicle Company survives from 1906, a copy of a letter signed by Christian Weeber. In that message, Weeber replied to a request from Electric Vehicle for information about supplying an exhaust cut-out (a device that allowed exhaust gas to bypass the muffler). Weeber's reply is reproduced here in full to give the reader a glimpse of his thinking about a design and supply challenge.

In reply to your favor of the 5th, we do not furnish cut-outs, but can make you one that will be neat and durable. And constructed to fit 1½ tapped hole (pipetap) so it can be used in tee or in inlet head of muffler, at an angle equal to head or parallel to side of muffler. It will be built of bronze or any suitable metal we may see fit, and will be guaranteed in every particular. Just what the exact cost will be we can not say, but will do our best to keep it as low as possible which will be between 2.00 and 3.50 each in quantities. If this is satisfactory we will send you a pencil drawing of constructions so you can make your shop blueprints from same if you desire to do so.

Trusting this will be satisfactory and thanking you for your kindness in this matter, we are

Yours respectfully,

C. F. Weeber Mfg. Works

Per C F Weeber

P.S. Please pardon delay in answering as our Mr. Weeber was out of town.¹⁷⁶

In spring 1907, Electric Vehicle had ordered additional mufflers and in late May requested "to receive as soon as possible some of the mufflers on our order #65501."¹⁷⁷ Weeber responded by mail the next day. One day after that (and testament to the efficiency of the postal system), Electric Vehicle agreed in a Saturday letter that ten mufflers could be shipped on the following Monday; "freight will be satisfactory."¹⁷⁸

¹⁷⁵Higgins to C. F. Weeber Mfg. Works, September 20, 1906.

¹⁷⁶C.F. Weeber Mfg. Works to Electric Vehicle Co., October 9, 1906.

¹⁷⁷William J. McAneeny, purchasing agent to C. F. Weeber Mfg. Works, May 23, 1907.

¹⁷⁸McAneeny to C. F. Weeber Mfg. Works, May 25, 1907. The alternative to freight would have been a more expensive express shipment. One wonders if Electric Vehicle worked a half or full day on Saturday.

On August 8, 1907, Electric Vehicle wrote a purchase order, Number 67878, for 235 mufflers, part number M-3577, "as shown on B.P. B-4447-A," at \$6.50 each. Delivery of 39 units was requested on September 1 with 39 on each of the following four months and finally 40 on February 1, 1908.

A Weeber letter in response to the purchase order survives. In it, the writer mentions that in the past the special order mufflers that had required "Special Jigs" had been billed at \$6.75. Now that the jigs were on hand, "we could make you a price on the 235 Mufflers at but a slight advance over regular, which would be \$6.50 each." Regarding a request to deliver mufflers in "six equal monthly shipments, the first beginning September 1, 1907," it appeared that the first shipment might take a little longer than one month to send "but if you will let us know immediately, it is quite likely we could come very close to it, at any rate would be able to get enough out so as not to inconvenience you with your shipments."¹⁷⁹

Notations on the purchase order include one in ink. "Ans. 8/10/07 will make shipment as outlined on order." The September and October 1907 delivery dates are crossed out in pencil. A check mark next to the November date is accompanied by a pencil notation, "10 shipped by Express 10/5."

A Weeber letter to Electric Vehicle from October 7, 1910, concerns experimental mufflers made for use on a Columbia engine.

In reply to your favor of the 3d., the two Mufflers sent you for your 5½ x 5½ Motor last spring, were not of our Standard Pattern. They were designed mostly to fill your requirements, and were both of somewhat different construction. These were made according to sketches drawn up for them, but through some oversight on our part, these have been mislaid.

You have likely tested both Mufflers, and find them to differ somewhat. If you will return the one most satisfactory, we could proceed immediately to make up drawings after it, and turn out any number you should require.

Trusting this is satisfactory, and hoping to hear from you favorably by return mail, we are,¹⁸⁰

¹⁷⁹C. F. Weeber Mfg. Works to Electric Vehicle Co., August 6, 1907.

¹⁸⁰C. F. Weeber Mfg. Works to Electric Vehicle Co., October 7, 1907. The surviving copy of the letter is unsigned.

Whether Electric Vehicle subsequently ordered mufflers to one of these patterns is undocumented in the Weeber collection at the New York State Museum. In August 1909, the Columbia Motor Car Company ordered another muffler for development purposes, specifically "1—Weeber Muffler M/3517 on B/3447-C" for a Mark 80 car. The purchase order was marked by hand in ink "Please rush—for test." Weeber noted on the order four days after it was written, "Sent 8/18."¹⁸¹ A final document from the Electric Vehicle-Columbia lot is a February 1910 purchase order for two mufflers "less Tubes M-4387 on C-4447-C." Weeber noted in pencil, "Sent via Frt. Feb. 23, 10 Wrote 2/23 Copy."¹⁸²

The documents described above account for hundreds of mufflers from 1904 to 1907. Columbia production figures for those years for both gasoline and electric autos are 1,937 for 1904; 1,213 for 1905; 1,816 for 1906; and 2,210 for 1907.¹⁸³ Conceivably, the C. F. Weeber Manufacturing Works might have been the sole muffler supplier during that time [not just in 1906 as noted in *The Argus* above].

Other automobile manufacturers interested in, or purchasers of, Weeber mufflers included the Winton Motor Carriage Company of Cleveland, Ohio, although a May 1906 letter from the Boston branch requested "prices of muffler for the Winton, and oblige."¹⁸⁴ Vernon Steinberger of West Liberty, Ohio, was a Winton owner who, in April 1909, contacted the Weeber Works about a muffler for his car. Weeber's reply suggests that the Winton Company may well have used Weeber mufflers on a regular basis.

We are in receipt of your favor of the 26th ult. Which had been mislaid. We should be pleased to quote you on our 2" special Muffler for your 04 Winton 2 cylinder which lists for \$20.00 for \$10.00 net. We will guarantee the Muffler to do the work desired, as we have many hundreds of them in use on the

¹⁸¹The purchase order, signed by T. [illegible ?] S. Hyatt, purchasing agent, is dated August 14, 1909. The order notes in the printed letterhead that the Columbia concern was the "Successor to the Electric Vehicle Company."

¹⁸²The purchase order is dated February 15, 1910.

¹⁸³Kimes and Clark, op. cit., p. 357.

¹⁸⁴Unsigned letter from Winton Motor Carriage Company to C. J. [sic] Weeber Mfg. Works, May 5, 1906.

Car in question, and have yet to hear from the first complaint on that particular Car.¹⁸⁵

Steinberger returned the Weeber letter noting that, "\$5 is all I would stand for an old style Muffler like above Mentioned = As I can get one of that size of Many Kinds, for \$4.50 to \$6.00 of late pattern. If you accept above offer, write at once." Christian Weeber marked the letter in pencil "1½" write will send without tubes same [illegible?] as Columbia" and "wrote 5/11 Copy." Whether Steinberger was able to buy a muffler for \$5 is unknown here.

In April 1908, the Jeannin Automobile and Manufacturing Company of St. Louis wrote to state, "we will be in the market shortly for a quantity of Mufflers." Responding to a Weeber advertisement in "an old edition" of the *Cycle & Automobile Trade Journal*, Jeannin said that they were using a Weeber "Muffler of your make on our Car which has thus far proven satisfactory. We bought it from a local Jobbing House paying \$2.25 for it." Jeannin was "building our own Cars" and so wanted a quotation on lots of a half-dozen Weeber mufflers. "For the present time this would be all we want" but Jeannin also wished a price in lots of ten. "Also send us full explanation regarding the Muffler."¹⁸⁶ Weeber noted on the letter "Ans. 4/20 Quote 60% from list."

The Southern Motor Works in Jackson, Tennessee, maker of the Marathon automobile, wrote the Weeber firm in July 1909 to ask about muffler prices in lots of 100 and 200. The muffler, with cut out, was to be used on a four-cylinder engine with "1-3/4 O.F. [exhaust] tubing." "Regarding dimensions will leave that to your own judgment. However, the length must not exceed 28 in. and the diam. 7 in."¹⁸⁷ Weeber notated the Southern letter in blue pencil, "8/11 Copy 70% Cutout Extra." In April 1908, the American Motor Car Company of Indianapolis wrote to ask for a quote on "a plain

¹⁸⁵C. F. Weeber for C. F. Weeber Mfg. Works to Vernon Steinberger, May 3, 1909.

¹⁸⁶E. P. Fritschle, president and treasurer, to C. F. Weeber Manufacturing Works, Ithaca [sic], April 17, 1908. Elsewhere in this work is a graphic showing a proof of a Weeber advertisement with an Ithaca address in error in the *Cycle and Automobile Trade Journal*. The car apparently was named for factory superintendent Harry W. Jeannin. Kimes and Clark note that Jeannin car production occurred only in 1908. The high wheel-type vehicle used a two-cylinder, air-cooled engine.

¹⁸⁷W. H. Collier, vice-president, to C. F. Weeber Mfg. Works, July 31, 1909.

cutout valve suitable for muffler pipe 2½" in diameter."¹⁸⁸

The Braithwaite Brokers Supply Company in Williamsburg, Virginia wrote to the Weeber Works in August 1909 looking for a muffler for a boat engine. Braithwaite...

...have sold for the past 12 yrs. Mufflers of every discription [sic], but have never had one yet that hav [sic] come up to my expectation. if [sic] you have this kind that we can use on a 7½ H.P. engine, 2 in. exhaust, send us your best jobbers trade discount. If you can make us your special price on this, as we are going to use it on our boat for demonstrating purposes only, and thare [sic] are over 500 boat owners in my territory, whom we have personal acquaintainces [sic] with, If you can send us a muffler for a 7½ H.P. engine 2 in. for five dollars, to use for demonstration purpose, send it to us at once C.O.D.

Christian Weeber marked the Braithwaite letter "Sent 8/24 Wrote 8/24." Whether any additional mufflers were sold to Braithwaite is unknown here. However, another boat owner seeking a muffler was W. O. Knudsen, who wrote on the stationery of the New York office of the Electric Storage Battery Company of Philadelphia. After an initial exchange of messages, on May 11, 1909, Knudsen wrote again and enclosed a sketch of the muffler he desired. Acknowledging the specifications that Weeber suggested—fifteen inch length and eight inch diameter—Knudsen asked for the muffler to be water cooled by having an inlet pipe at the top of the horizontal unit and a drain pipe at the bottom. The "entire" cooling water from the engine would pass through the muffler. "If I cannot cool the muffler, I shall have to use some other type, as its position in the boat makes it impossible to let it get excessively hot." Knudsen included a sketch of the muffler arrangement he sought.¹⁸⁹ Weeber noted on the letter, "Write we will build as per sketch" and "Sent 5/19 via express Wrote 5/19 copy."

An exchange of letters after installing the water cooled mufflers suggests that engine performance was negatively affected. On August 19, 1909, Knudsen said:

¹⁸⁸L. G. Payne to C. F. Weeber Mfg. Works, April 11, 1908. Weeber marked the letter "An 4/14/ ..." (Remainder illegible).

¹⁸⁹W. O. Knudsen to C. F. Weeber Mfg. Works, May 11, 1909.

...beg to state that in sending you our first inquiry regarding Muffler, we specified that the engine with which it was to be used was a single cylinder, two cycle with 5½" bore and 5" stroke, 650 revolutions a minute; by putting on a new wheel the number of revolutions has been reduced to 600, but the speed of the boat increased. The number of revolutions without muffler, with the old muffler and with your muffler are 610, 600 and 540 respectively.¹⁹⁰

In March 1908, the Todd Rubber Company, a tire dealer in New Haven, Connecticut, wrote to ask about Weeber specialties, "particularly that relating to mufflers." Todd said they were "in the market at the present time for one muffler and anticipate having several more orders within a few weeks."¹⁹¹ Christian Weeber, giving instructions to an assistant, marked the Todd letter "Ans. 3/24 M [illegible?] 50; V7, SR. 30%; WP20."

James C. Fitzgerald, treasurer of the J. B. Lyon Company, publishers and printers in Albany, wrote to the Weeber firm on Lyon stationery in January 1908.

Some weeks ago I arranged with Mr. Weeber on the street to put one of your mufflers on my car. This car is in Knox & Schaiber's #103 Spruce Street and will be in condition for you to go ahead by day after tomorrow. I am anxious to get this work completed as soon as possible in order that the car may be painted. I am informed that all of the other parts will be assmbed [sic] by the end of the week. Therefore please to this as soon as you can.

Please equip the muffler with cut out.¹⁹²

In December 1906, the Argus Company in Albany provided Weeber with 500 muffler broadsides at a cost of \$6. On March 28, 1907, the Argus firm billed \$6 for "500-4pp Circulars *Muffler*."

In March 1909, *The Argus* noted that Christian Weeber was the inventor of the "Weeber muffler, the Weeber shock-reliever, a wheel-puller and a valve-tool, automobile appliances that are sold all

¹⁹⁰W. O. Knudsen to C. F. Weeber Mfg. Works, August 19, 1909. Weeber notes that he responded, "8/27 Copy."

¹⁹¹E. J. Todd, president, to C. S. [sic] Weeber Mfg. Works, March 23, 1908.

¹⁹²James C. Fitzgerald to C. F. Weeber Mfg. Company, January 29, 1908.

"Exide Accumulator"

THE ELECTRIC STORAGE BATTERY CO.

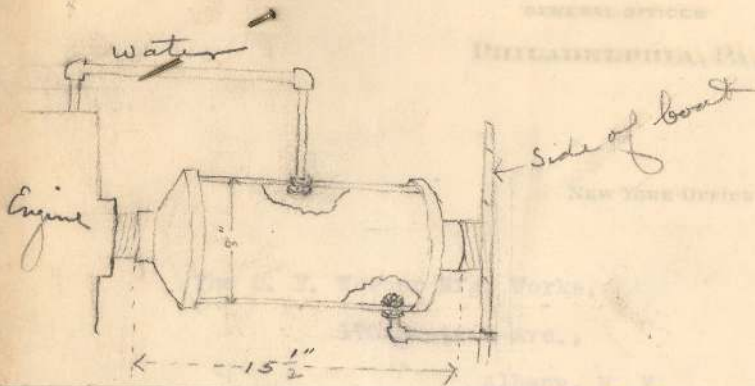

BROADWAY May 11, 1909

Gentlemen:-

I have your letter of the 7th inst. and am glad to know that you think you can make up for me a muffler 15-1/2" long suitable for my engine.

I presume that better results could be gotten if this muffler ~~was~~ ^{were} made 8" in diameter instead of 6".

Do you think that there will be any danger in water cool-

2" x 8" Castings
6" tubes.

water is piped into
and a drain kept open
shown in the rough
n drain out immediate-
after stopping would

ter exclusively, so
be with salt water
muffler of your type.

right, I shall be

e pipe size is, as

write we will
build as per sketch

Sent 5/19 via express.
Wrote 5/19 copy

Figure 4.6: The sketch of the water-cooled muffler installation W. O. Knudsen attached to his letter asking the C. F. Weeber Manufacturing Works to fabricate a muffler for use in his boat. NYSM Collection, H-2000.39.NN.

over the United States, and for which his Albany works is the central supply depot.”¹⁹³

Early advertising from the summer of 1902 took the form of eighth-page displays in the monthly *Cycle and Automobile Trade Journal*. The issue for July 1, 1902, listed six reasons to use the device. The claims, interestingly for observers a century later, reflect the state of automobile development then noting even the competition for markets by steam-powered cars.

1. No noise from exhaust, (quiet as steam)
2. No loss of power from engine
3. Small in size, can be placed anywhere
4. Cheap in price, considering goods
5. Can be made for all sizes in motors
6. Can be put on any carriage in use
7. If interested, write for prices.

Beginning with the September 1, 1902, issue the “Six Reasons” gave way to “Why Not Use the Weeber Muffler?,” a headline that continued through April 1, 1904.

Also for September 1, 1902, the text added that Weeber muffler “Stock [was] carried by A. L. Dyke, St. Louis, Mo.,” a pioneer manufacturer and distributor of automobile parts. For February 1, 1903, a change noted that “Stock Carried by Neustadt-Perry Co. St. Louis, Mo.” Similar advertisements continued through December 1, 1903, indicating a distribution arrangement with Neustadt-Perry lasting at least that long. The Neustadt operation reportedly manufactured a “full line of gasoline engines, hoods, fenders and tanks besides dealing in all other parts of steam and gasoline automobiles. They are pioneers in the manufacture of parts and their products reach all parts of the world.”¹⁹⁴

A full page Weeber muffler advertisement appeared in the January 1, 1903, issue of the *Cycle and Automobile Trade Journal*. The address given for the Weeber Manufacturing Works was 256 Sherman Street. Perhaps this was an error in copying

¹⁹³March 28, 1909.

¹⁹⁴*Cycle and Automobile Trade Journal*, December 1, 1903, p. 80. Accompanying photos show portions of the body fabrication and running gear shops. The author of the present text recalls that Andrew Lee Dyke sold his business in the early twentieth-century. Apparently the buyer was Neustadt-Perry. Dyke is also known as an author of such works as the *Automobile and Gasoline Engine Encyclopedia*, appearing in many editions.

the correct number, 255. Or perhaps, and likelier, it was Weeber’s means for assessing response to a more expansive advertisement. In any case, the text in the piece noted that the muffler could be used on any automobile or on a stationary engine (“You will forget you have a gas engine in your factory.”). There was note, also, of a “special size for motorcycles” and of the Weeber “steering and braking device with which the vehicle is always under perfect control.”

For June 1904, the small display advertisement noted that there was a “Big Reduction in Weeber Mufflers.” The maker could “quote interesting prices to manufacturers and users of Stationary, Marine and Automobile Motors.” For January 1, 1905, *Trade Journal* readers were advised that it was to be a “Weeber-Muffler Year As shown by the way manufacturers are adopting the New Pattern everywhere, on all kinds of cars from the best to the cheapest.” Now the Weeber Works address was given as “Perry Street” in Albany.¹⁹⁵ Again, it’s possible that Weeber was looking for a means to gauge response to his advertising expenditures.

The *Trade Journal*, in the same January 1905 issue, published a three paragraph story with two photographs describing the “1905 Weeber Muffler,” which, after four seasons on the market had “been recently improved.” Now the muffler was “simpler, “neater” and “more efficient also.” Asbestos cord packing was being used to seal the steel jacket to the inlet and exhaust heads. Made to fit one- to four-inch pipe connections, the prices ranged from \$10 to \$40.¹⁹⁶ The *Automobile Review*, in its October 22, 1904 issue, also described the new muffler as a slightly shorter article nevertheless using the same two illustrations.¹⁹⁷

After a period (March through June 1905) of not advertising in the *Trade Journal*, the Weeber Manufacturing Works returned with a quarter page advertisement enticing readers with “an opportunity to figure with you on MUFFLERS for 1906.” The new model reportedly had “been used by some of the largest automobile manufacturers for the past year and gives better satisfaction than any muffler on the market.” Special note was made of the 1.5-inch muffler in stock for 1902, 1903 and

¹⁹⁵Weeber’s Sherman Street operation was a short distance east of Perry Street, later known as Lake Avenue.

¹⁹⁶P. 256

¹⁹⁷P. 404.

1904 Winton cars. This would make a “new car of your old one. We guarantee satisfaction or refund money.”¹⁹⁸

Other venues for Weeber muffler advertising included *The Horseless Age*, a large format magazine in contrast with the smaller (height and width) but thicker, *Trade Journal*. In the January 10, 1906, issue of *The Horseless Age*, a Weeber muffler advertisement is rather difficult to find, being located towards of the bottom in the central column of three on a page containing 29 small display advertisements. The headline for the Weeber ad notes that “1906 Mufflers” were a “New model...being used by the large manufacturers...Will give full power to motor and pleasing tone to exhaust. Satisfaction guaranteed or money refunded.”¹⁹⁹ *The Automobile Review and Automobile News* was still another venue for very small (ca. 1.5- x 2.5-inch) display ads for the Weeber muffler.²⁰⁰

In September 1909, The Igniter Appliance Company in Cleveland wrote to say that “in connection with the manufacture of a new gas engine... would be pleased to have your descriptions and price list of mufflers... We take your name from the Automobile Trade Directory.”²⁰¹ And in April 1910, The Bossert Company in Utica, makers of outlet boxes and sheet metal stampings with “Automobile Parts a Specialty,” wrote:

We note you are a manufacturer of mufflers. We make a lot of muffler discs for a local concern. These are made of pressed steel. We would be very glad to quote on any stampings you may require for your mufflers or any other articles you are manufacturing requiring stampings.²⁰²

¹⁹⁸Quoted from the November 1, 1905 issue, p. 257. Such advertisements ran from the July 1, 1905 through the December 1, 1905 issues.

¹⁹⁹Vol. 17, no. 2. On another page a similarly sized display advertisement touts the “Yankee Muffler,” the product of D. B. Smith & Company in Utica. The patented device used expanding disks so it could not “explode or clog...A vacuum created draws the burnt gases from cylinders overcoming back pressure, 15 percent more power.”

²⁰⁰These appeared in the advertising section in the twice-monthly *Review* from the first January through the first April issues of 1903.

²⁰¹C. W. Hunt for The Igniter Appliance Company, September 10, 1909. Weeber noted “Write 9/12 Copy.” The Weeber display advertisement in the 1911 Albany city directory noted the firm was “Manufacturers of the Celebrated Weeber Muffler.”

²⁰²James R. Jones, general manager of The Bossert Company, to C. F. Weeber Mfg. Works, April 28, 1910. The only recipi-

A handbill for another manufacturer’s muffler survives in the Weeber collection at the New York State Museum suggesting that Christian Weeber was aware of competing designs. The “Auto-Power” muffler was the product of the Auto and Power Appliance Company of Cleveland, Ohio.²⁰³

Advertising for the Weeber muffler continued at least until 1911.

Steering and Braking Device and Steering Gear

A second patent from 1902, number 704,156, granted on July 8, 1902, is a combined steering and braking device “by which the steering and braking may be accomplished by the movement of the same handle and that both operations may be performed at the same time.”

The *Cycle and Automobile Trade Journal* for August 1, 1902, announcing the Weeber patent, said the device was “one of the best things for light automobiles. Both steering and braking are with it, always under control, increasing the factor of safety wherever fitted. The firm also expects to be in position before long to furnish them to fit larger vehicles.”²⁰⁴ Introduced in a period during which steering wheels replaced handles (tillers), it would seem that the Weeber invention had limited potential.

An article in the May 1904 issue of the *Cycle and Automobile Trade Journal* describes a different Weeber steering gear, one subsequently advertised for sale. The *Journal* text said:

The steering gear is specially designed with a view of doing away with lost motion entirely. It is made of bronze and steel, each metal so placed that it will best serve its purpose. The gears are accurately cut from solid stock by the most modern gear-cutting machinery. The small hardened pinion is keyed to the shaft and a split cotter pin extends through the end of the shaft to prevent the pinion or key from falling off should the latter become loose. All

ent notation on the letter is a pencil check mark. The trade journals, e.g., *Cycle and Automobile Trade Journal*, periodically published lists of suppliers including the Weeber Manufacturing Works.

²⁰³The handbill is undated. Its last panel reads, “Consign to the waste basket and you will have missed ‘IT.’” H-1933.6.335.

²⁰⁴P. 17.



NATIONAL
Kerosene Oil Burner.
Best in the world
for Stoves, Cars,
Hundreds now in
use. Write for cir-
cular and names of
entitled custom-
ers.
National Oil Heating
Co., Welles, Mass.



Jump Spark Coils
The best coil for
Automobiles,
Launches and
Stationary Engines
THE INDUCTION COIL CO., Milwaukee, Wis.

W. J. Kells Manufacturing Co.
THE ONLY GENUINE HONEYCOMB WATER COOLER
POSITIVELY GUARANTEED NOT TO LEAK
Mfrs. of Honeycomb Water Coolers, Mud
Guards, Tanks, Mufflers, and Hoods.
62-66 Van Winkle Avenue,
JERSEY CITY, N. J.

TIRE PROTECTORS
For Automobiles
LEATHER TIRE GOODS CO.
Newton Upper Falls, Mass.

EVERYTHING IN
Automobile Supplies
SEND FOR CATALOG
AUTOMOBILE SUPPLY CO.
1339 Michigan Blvd. CHICAGO, ILL.



THE BEST YOU
CAN GET is the
Worst of it, if you
use a bum spark
plug. Try a "Me-
chanical" Plug and
be happy.
Send \$1.50 and receive a sample plug by return
mail. Write for circular.
MECHANICAL PLUG CO., 3924 Olive St., St. Louis, Mo.

THE BUCKEYE
Manufacturing Company
MANUFACTURERS OF
The "Lambert" Automobiles
Anderson, Indiana, U. S. A.

ESSEX ENGINEERING CO.
54 NASSAU ST. NEWARK, N. J.
WE DO EVERY KIND OF EXPERIMENTAL WORK
DRAWING PATTERNS CASTINGS MACHINE WORK
AND ELECTRIC WORK. ACCURATE AND RAPID.
SEND FOR ESTIMATES.

COMPLETE LISTS
OF
Auto Owners, Dealers, Garages & Jobbers
MOTOR DIRECTORIES COMPANY, Inc.
SUCCESSOR TO AUTO DIRECTORIES CO.
105 Fulton Street, New York City



Yankee Mica Spark Plug
Price \$1.50.
Compression End—
Double Insulated Mica.
Guaranteed 90 Days.
Everything for the Automobile. Mammoth Catalog 10 cents
in Stamps.
E. J. WILLIS CO., 10 Park Place, New York.



No other
"Just as Good"
Double Explosion
Chamber
Excelsior
CLEVELAND
Price, \$1.50 all sizes
Postpaid
Guaranteed
for one year
Excelsior Spark Plug Co. Dept. H.
CLEVELAND, OHIO

Syracuse Aluminum and Bronze Co.
SYRACUSE, N. Y.
Aluminum—Castings—Bronze



Terminals, Cables, Battery
Connectors, Spark Plugs,
Carburetors
**Everything Else for
Autos**
CHAS. D. SHAIN
Auto Specialist
70 Murray Street, New York



CHAIN TOOL
35c
THE HUSKY KIND
SENT PREPAID FOR 45c
THE MOTOR CAR SUPPLY CO.
1427 MICHIGAN AVENUE CHICAGO, ILL.



POCKET
Battery Ammeter
0 to 30 Amperes.
Indicates in any position and in
either direction of current.
In testing single cells, the cord is
not necessary.
Price \$3.50.
ELDRIDGE ELEC. MANUFACTURING CO.,
Springfield, Mass.

NOISELESS SPINIONS and
METAL GEARS.
THE NEW PROCESS RAWHIDE CO.
SYRACUSE, N. Y.

THE SOLVAY PROCESS COMPANY'S
"KAL-KRYSTAL"
MAKES THE BEST NON-FREEZING SOLUTION FOR
AUTOMOBILE USE.
Neutral and non-corrosive. Stands 50 degrees below zero Fahr.
Put up in 10-pound cans. Makes 2 gallons of solution ready for
use. For sale by all Automobile Supply Houses.
CARBONDALE CHEMICAL CO., Carbondale, Pa.



1906 MUFFLERS
Our new model is being
used by the large manu-
facturers. Is very quiet,
durable and free from
back pressure. Will give full power to motor and
pleasing tone to exhaust. Satisfaction guaranteed or
money refunded.
C. P. WEEBER MFG. WORKS, Albany, N. Y.



SPROCKETS
Chains and Differentials
CULLMAN WHEEL CO.
1025 DUNNING ST., CHICAGO, ILL.



Robert Volt-Ammeter
For General Battery Testing
GUARANTEED
Tests both volts and amperes.
3 volts—30 Amperes
10 "—30 "
Send for catalog and prices.
ROBERT INSTRUMENT CO.
55 Shelby St. DETROIT, MICH

THE EXCELSIOR is the leader of Jump
Spark Plugs. It is the only plug that can
be cleaned of soot or oil without removing it
from the engine. Costs no more than the com-
mon kind, which it outclasses in every feature.
WRITE FOR PRINTED MATTER.
Excelsior Spark Plug Co. Dept. H.
CLEVELAND, OHIO

See our **STEAM SPECIALTIES** in operation
at the 69th REGIMENT ARMY AUTO SHOW
IN THE BASEMENT.
F. W. OFELDT & SONS
Nyack-on-the-Hudson (only), N. Y.

We Make Commercial Vehicles
only, and we make good ones. Every power wagon
we build fully guaranteed for one year.
Rapid Delivery Wagon, Model B, \$1,250 f. o. b. Detroit.
18 h. p. double opposed motor, will carry
over 2,000 lbs. Other models.
Rapid Motor Vehicle Co., Detroit, Pontiac, Mich.

John A. Straley
Louis B. Hasbrouck
C. Augustus Dieterich
PATENTS
And PATENT CAUSES
STRALEY & HASBROUCK
COUNSELORS-AT-LAW
SOLICITORS OF AMERICAN AND FOREIGN PATENTS
257 BROADWAY, NEW YORK, N. Y.
Patents, Designs, Trademarks, Labels and Copyrights.

HYATT ROLLER BEARINGS
TURN FRICTION INTO ENERGY
HYATT ROLLER BEARING COMPANY
HARRISON NEW JERSEY
ARE YOU FROM MISSOURI?

The Bullock Ignitor was the
original
primary
sparker. Can be readily applied to any engine.
Beware of worthless imitations. Ask for the
New Duplex Model. If your dealer cannot supply
you, order direct. Bulletin "H" mailed
on request.
BULLOCK IGNITOR COMPANY Cleveland, Ohio



Auto Screw Jack.
Easy to Operate, Strong, Light,
Compact and Quickly Adjusted.
No. 601 weighs 7 lbs.; will lift 2,000
lbs., and adjust in height
from 11 to 17 inches.
COVERT MFG. CO., Troy, N. Y.

JUICE FOR YOUR BATTERY
THE
Apple
Why not generate your own "juice" for
your batteries? You can do it with an
Apple Automatic Battery Charger. Easily
attached to any automobile or gas engine.
Requires no attention. Generates a steady,
strong current, enough to keep your bat-
teries always charged and to keep a light
running besides. See us at N. Y. and Chi-
cago Auto Shows. The Dayton Electric
Mfg. Co., 88 Beaver Ridge, Dayton, Ohio.
**Automatic
Battery
Charger**



**SPARK
PLUGS**
DOUBLE MICA INSULATION.
SUPERIOR CONSTRUCTION.
18 MM. and 3/8 in. standard, \$1.00 each.
F. H. RICHARDS, 15 Murray St., New York.

Make your machine run easy by using
"Esso" Lubricating Graphite
OVERCOMES ALL FRICTION
Put up in 5 and 10 lb. cans. Special prices to dealers.
THE S. OBERMAYER CO.
CINCINNATI CHICAGO PITTSBURG

Figure 4.7: Display muffler advertisement from *The Horseless Age*, January 10, 1906, p. LII. NYSM Collection, H-1933.6.338.

No. 704,156.

Patented July 8, 1902.

C. F. WEEBER, JR.
STEERING AND BRAKING DEVICE.

(Application filed Dec. 13, 1901.)

(No Model.)

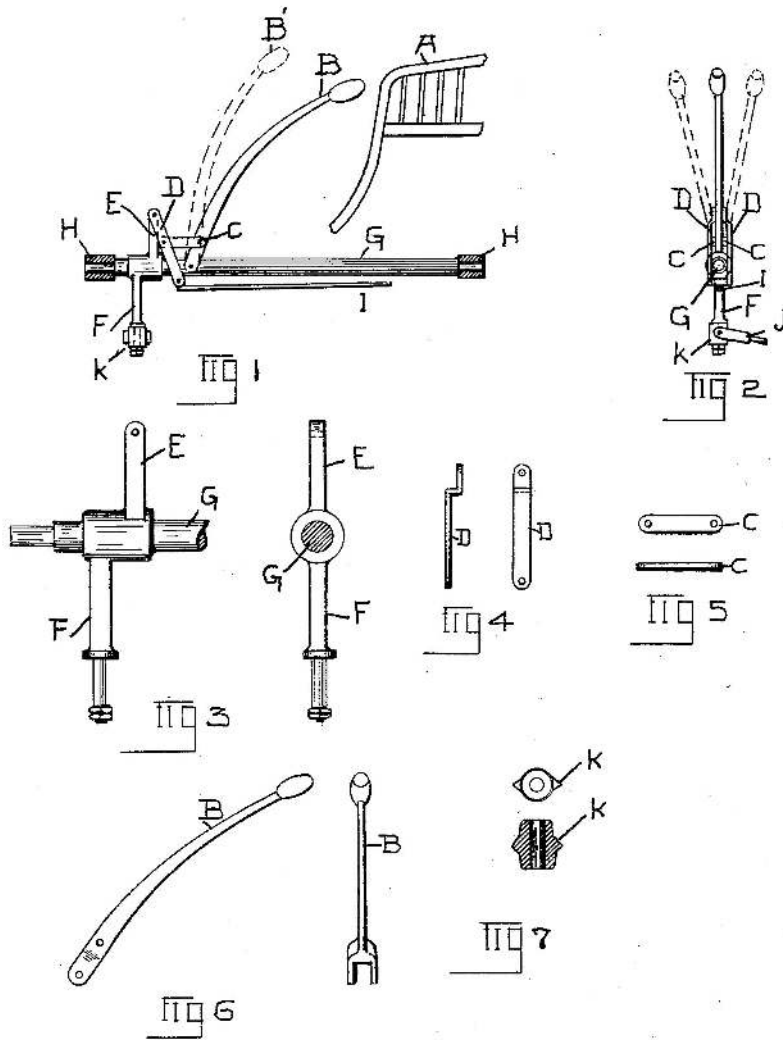

WITNESSES
Lottie Prior,
William Fairchild

INVENTOR.
BY *Christian F. Weeber, Jr.*
Ward & Cameron
his ATTORNEYS

THE HOBBS & VICTOR CO., PHOTODUPLICATION SERVICE, INC.

Figure 4.8: Patent illustration of the Weeber combined steering and braking device. Courtesy of <http://www.uspto.gov> United States Patent Office.

other adjustable parts also have the protection of split cotters. The frame plate measures 6 x 8 and is provided with four lugs for fastening to the bottom of the footboard. The bearing for the steering column is made to slide towards the quadrant by simply turning a small screw, not shown in the cut. This is, therefore, instantly and easily adjustable for wear. The pinion is accurately cut and is hardened. It works freely when drawn up tight. The quadrant has a 4½-inch bearing and turns on a 1-inch, hardened stud, which also has means of adjustment. The bronze arm holding the connecting swivel can be made for any angle of connections.²⁰⁵

Apparently the steering gear did not incorporate patented or patentable designs. A letter in the Weeber collection at the New York State Museum indicates interest in the steering gear as late as December 1907. That was the point at which Burt Brown, doing business as the B-Bee Garage in Malone, asked for "Catalogue and prices of your Steering Gears." If Brown was not familiar with Weeber specialties through advertising, perhaps he knew Christian Weeber as fellow Maxwell automobile dealer.²⁰⁶

The Weeber Manufacturing Works did advertise the steering gear. A retouched photograph of the gear survives in the Weeber collection at the New York State Museum. The image appears in a 1/16th page display advertisement in the May 1, 1904, issue of the *Cycle and Automobile Trade Journal*. "A gear you can keep adjusted in mesh, making positive steering. Quadrant has 4½" bearing adjustment; travels 180 degrees on hardened pinion and cannot run off. Write for prices."

Key Plug Switch

A Weeber switch for an automotive electrical circuit was announced in 1904. The *Cycle and Automobile Trade Journal* said the...

²⁰⁵P. 110. The image is one surviving in the Weeber collection at the New York State Museum. A photo of the gear is shown below the text "Weeber Steering Gear."

²⁰⁶B. Brown to Weeber Mfg. Works, December 17, 1907.

Weeber noted in pencil "Ans 12/18." Brown's letterhead claimed he operated the "Pioneer Garage of Northern New York" with "A Complete Line of Automobile Accessories Always in Stock." Two halftones of Maxwell cars also appear on the stationery.

... point kept particularly in mind in designing the switch was the production of one that would not short circuit and one that would at all times make a positive contact. Neither nails nor plugs from other cars can make contact in this switch. It is a double switch for use with two sets of batteries or two generators and is easily moved into connection with one or the other. The contact springs are fastened [fastened] on the insulator block in such a manner that they cannot be strained and a positive contact is, therefore, certain.

This Key-Plug switch is made of polished brass and measures 2¼ x 3 in. The proper material is used in the knob to look well and prevent shocks. Price is \$1.25, for which it will be sent by mail postpaid.²⁰⁷

Advertising cuts for the key plug switch survive in the Weeber collection at the New York State Museum. The image appears in identical Weeber advertisements in the May, June and July 1904 issues of the *Cycle and Automobile Trade Journal*. "A switch that is wanted for Automobile, Launch and stationary purposes. Cannot short-circuit, and will always make positive connection. No nails and plugs of other machines will fit this. Cannot enter, if they do will not make contact. Made in polished brass. Sent postpaid for \$1.25, with discount in quantities."

Shock Reliever

While the Weeber muffler and other Weeber "specialties" clearly were inventions devised and patented by Christian Weeber, the shock absorber manufactured and marketed by the C. F. Weeber Manufacturing Works, in spite of newspaper and journal attribution to Christian Weeber, was, as recounted below, the brainchild of another man, Fletcher W. Battershall.

In early August 1906, *The Horseless Age* reported that the C. F. Weeber Manufacturing Works at 255 Sherman Street in Albany recently had begun manufacture of a "shock reliever of novel design." The story continued by describing:

... the motion of the sliding bar [that] opposes the action of the coiled springs when the vehicle spring compresses, and increases it when the vehicle spring rebounds, so that the retarding action is much greater during the re-

²⁰⁷P. 110.

bound. The more violent the shock to which the vehicle springs are subjected the tighter the clutch will hold.²⁰⁸

Motor for September 1906 also announced production of the Weeber Shock Absorber using phrases similar to those in *The Horseless Age*.

The Argus reported the following:

The C. F. Weeber manufacturing works, which has the finest and largest automobile repair and manufacturing shop in this city, has been working on many new devices to improve automobiling. The latest patent is the Weeber shock reliever. With this device greater comfort can be taken when riding over rough streets and country roads.

This device is very simple and can easily be attached to any automobile. Its action is very different from any other invention for this purpose. It does not affect smooth riding over even roads, but only acts when rebounds take place; the more violent the shock the tighter is the clutch.²⁰⁹

In early September 1906, Mr. and Mrs. Charles [sic] Weeber, Jr., in a Maxwell car, Mr. and Mrs. Emil Weeber in a Corbin and F. A. Harrington, Jr., in a Ford, made a two-day trip through the Berkshires "by way of Troy." The roads were "splendid" and the cars required no more attention than refueling. At Pittsfield, *The Argus* reported, Weeber's new inventions were "favorably commented on, several of the dealers in that city arranging to have them placed on the market."

The same issue of the newspaper noted that Weeber "of the Central Automobile Company" late in the month was going to Chicago to display "his new inventions, the shock reliever and muffler and several other of his devices" in space 87 at the First National Auto Part Show to be held in the First Regiment Armory. The idea of the show was to give foreign and domestic makers of parts and accessories an exclusive venue for display. Previously, such items were shown "in connection with

²⁰⁸*The Horseless Age*, vol. 18, no. 6, August 8, 1906, pp. 184-185. Two weeks later the magazine noted that their illustration of the shock reliever "was inadvertently placed upside down" and that the bar actually is a "flexible blade." One other correction noted that the reliever was available "at present" only in one size rather than the two announced in the earlier story.

²⁰⁹August 19, 1906.

automobiles shows."²¹⁰ A receipt from the Storey Furniture Company on Wabash Avenue in Chicago documents that "C. F. Weeber & Co., 1st Regiment Armory" rented a five-foot table at a cost of \$3.50 for use at the show. Returning from Chicago on October 2, 1906:

Mr. Weeber reports a very successful trip. The auto devices were enthusiastically received by the manufacturers and agencies were established from Ohio as far west as California. Ten cases of goods were taken for inspection and were arranged about the large space that had been assigned Mr. Weeber. There was but one complete machine at the show, and the muffler and shock reliever were placed upon it. The car also bore a display sign advertising the invention.

Six manufactories have placed the goods on market, while others have considered them favorably. On his return Mr. Weeber stopped at Cleveland, Detroit and Buffalo, where his goods were placed on trial by the large automobile firms of these cities.²¹¹

In early November 1906, Weeber returned to Albany "from a tour of the principal cities in Connecticut" to place his inventions "before eastern manufacturers." Within a few days, he headed to New York to arrange exhibit space for "his goods at the great show to be held in January" 1907.²¹² While in New York, Weeber. . .

illustrated the fact. . . that you cannot get the better of an Albany man. He made a flying trip to the metropolis for the purpose of securing space at the show to take place in December. His request was met with the reply, "there is no room. there [sic] are forty ahead of you." Instead of coming back to the city, Mr. Weeber went to work and hired a building of his own directly opposite Madison Square Garden, and now instead of having his inventions exhibited with the others

²¹⁰*The Argus*, September 9, 1906. *The Horseless Age*, vol. 18, no. 14, October 3, 1906, listed the C. F. Weeber Manufacturing Company [sic] as an exhibitor of Weeber shock relievers and mufflers at the Automobile Parts, Appliances and Accessories Exhibition from September 22 through 29 at the First Regiment Armory. Weeber's involvement with the Central Automobile Company is described in the text below. *The Argus* for September 23, noted that Weeber "will leave today for Chicago." Space 87 had been "reserved for him by Mr. A. M. Andrews, secretary of the exhibition."

²¹¹*The Argus*, October 7, 1906.

²¹²*The Argus*, November 4, 1906. Weeber probably was arranging for the December 1906 show.

he is to have a show of his own. The building will be equipped with machinery and demonstrations will be held during the days of the show. From now on until December, Mr. Weeber and his men will work day and night making the shock relievers and mufflers and getting them ready to ship to New York²¹³

And in Albany:

The forces at the C. F. Weeber Manufacturing Company [sic], on Central Avenue, are working day and night in order to get ready to whip Mr. Weeber's inventions to New York for the automobile show to take place December 1 to 8.

Mr. Weeber will occupy a store directly opposite the exhibition, where demonstrations will be made of the several devices. He is preparing souvenir circulars in which are testimonials of the special advantages of the shock relievers and muffler, with other interesting data. At the show three of the company's western agents will be in attendance.²¹⁴

A week later, Weeber was in New York, where:

Several of his inventions are on display in the jobbers department of the show proper, and in a building opposite the palace, which Mr. Weeber has hired for the occasion. Demonstrations of the qualities of the shock reliever and muffler are taking place daily, while there is a carload of goods on display.²¹⁵

Weeber also planned to "exhibit his inventions" at the Buffalo automobile show at the Conventions Hall scheduled for mid-February 1907.²¹⁶

One assumes the shock absorbers were fabricated at the Weeber Manufacturing Works facility on Central Avenue in Albany. Perhaps the 200 pieces of "O.H. Spring Steel 18in x 1 3/4" Scant x 17 Ga." that was "H. & T. Polished" weighing 121 pounds and shipped on the Pennsylvania Railroad in November 1906 by Henry Disston & Sons in Philadelphia was intended for use in making shock relievers. The charge to Weeber was \$13.91.

Frank W. Knapp, "Photo-Artist" at 32 North Pearl Street in Albany, on July 28 billed "Mr. Weeber, per Mr. F. Battershall" for work on July 12:

²¹³*The Argus*, November 18, 1906.

²¹⁴*The Argus*, November 25, 1906.

²¹⁵*The Argus*, December 2, 1906. The paper reported on December 9 that Weeber "will return to the city today" from "exhibiting his inventions at the New York show." *The Argus* noted among attendees at the show was Weeber's partner in the Central Automobile Company, Harry Sutherland.

²¹⁶*The Argus*, September 14, 1906.

making one 8 x 10 negative and a print for \$3 and duplicate 8 x 10 prints at \$.50 each for a total of \$4. Then the Austin Engraving Company of Albany on July 25, 1906 billed the C. F. Weeber Manufacturing Company \$1.50 for a half tone of the "Shock reliever" as well as \$.75 for the engraver's time in "cutting out" (at \$.60 an hour). The statement also documented a \$.70 charge for two electrotypes. One might surmise the half tone was made from the Knapp photograph, a possibility although, as will be seen below, the Austin firm billed Weeber for other work in February and July 1906.²¹⁷

In late 1906 the Weeber Works contracted for a quarter-page advertisement in the *Official Manual, Guide and Book of Reference of the Professional Chauffeurs' Club of America*.²¹⁸ In January 1907, the club subsequently billed the Weeber firm for \$20. In fact, the advertisement was for "Weeber's Shock Relievers." A halftone of a shock reliever installation is labeled "Weeber Shock Reliever Patents Pending." The adjacent text perhaps was tailored to chauffeurs operating expensive autos by noting that "Special Relievers now on hand to fit all prominent cars. Special patterns will be made to order to fit any car without extra cost." The product was guaranteed to "give absolute satisfaction, or we will refund the money." The address given for the Weeber Works was 170-172 Central Avenue.

One shock absorber patent (and the only such patent for the Weeber shock reliever with which author is familiar) likely was that granted to Fletcher Battershall in April 1907. His life and work are described below. Why Christian Weeber chose to advertise in the *Chauffeurs' Club Manual* is a minor puzzle. At the start of 1907 the club only had 165 members. Their names appeared in the club publication. It's likely most of these men were based in New York City, where the club headquarters were located at 1775 Broadway.

²¹⁷Later Austin bills are dated May 1, 1907 for "Mdse." from November 1906 to January 1907. The total was \$23.29 against which there was a credit of \$6.50 "By Contra c/k of Howard Martin" for \$6.50. The Austin bill, paid on May 2, 1907, is marked by hand in pen, "Can you let us have check to use on May 4th?" Another Austin bill, dated July 10, is for unspecified merchandise produced on May 18, 1907. This second bill was paid on July 10.

²¹⁸The book has no publication data other than a 1907 copyright. The author inspected a copy stamped "Library of Congress Two Copies Received Feb 21, 1907 Copyright Entry Feb. 6, 1907... COPY B."

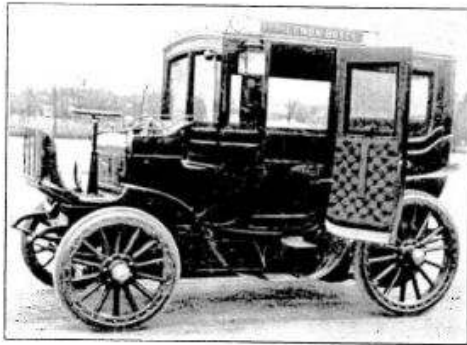

THE AUTO CAR EQUIPMENT COMPANY
DEALERS IN GASOLINE AND ELECTRIC VEHICLES
BUFFALO NEW YORK

Auto Tops

Glass Front Wind Shields
Slip Covers Baggage Racks
Iron and Steel Work

W. J. Duane & Co.
304 West Fifty-fourth Street
NEW YORK CITY

Telephones 6770 and 4773 Colubus

If you will fit your car with

Weeber's Shock Relievers

rough roads and streets will ride like boulevards. Every set guaranteed to fit and give absolute satisfaction, or we will refund the money. Special Relievers now on hand to fit all prominent cars. Special patterns will be made to order to fit any car without extra cost.

C. F. WEEBER
MFG. WORKS

170-172 Central Ave.
ALBANY, N. Y.

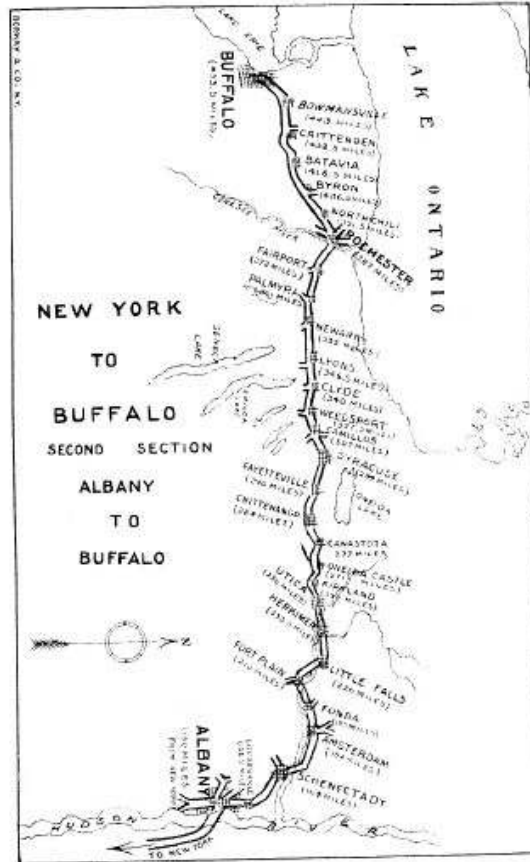
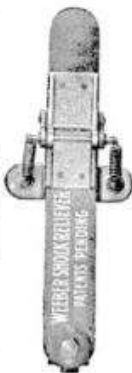

Don't Be Detained for Hours in a Police Station. Carry Your Bondman in Your Automobile.
NATIONAL SURETY COMPANY, 346 Broadway.

Figure 4.9: Weeber Shock Reliever advertisement appearing in the *Official Manual Guide and Book of Reference of the Professional Chauffeurs' Club of America*, 1907. Courtesy of the Library of Congress.

Most of the advertisements in the *Manual* were for businesses located in New York City, although one other Albany firm, the Taylor Automobile Company, is represented in a half-page display advertisement touting sale, storage and repair of cars and a Locomobile agency. Perhaps Christian Weeber thought that by reaching chauffeurs with information about his shock absorber, he would influence those drivers to guide their employers to buy the Weeber Shock Reliever. Two other advertisers of shock absorbers—Diezemann Shock Absorber of Hoboken, New Jersey, with a full page ad, and the Hartford Suspension Company of New York, distributors of the Truffault-Hartford Shock Absorber, with a half-page ad—may have had similar thoughts. In fact, the Hartford copy begins by calling for the attention of “Owners—Chauffeurs—Manufacturers.” Perhaps Christian Weeber was approached by an advertising salesman at an auto show or other event in New York City, where he had frequent business.²¹⁹

On March 13, 1907, the Argus Company billed the C. F. Weeber Manufacturing Works 90 cents for six electrotypes and \$6.75 for 1,000, four-page “Shock Reliever” folders.

Dr. William E. Milbank and T. J. Stephens, Jr., were local buyers of both the shock absorber and the muffler. “Albany autoists find these devices, which are the inventions of an Albany man, a decided help toward easy riding and are having them added to the equipment of their cars.”²²⁰

Another local customer for the Weeber Shock Reliever was John Thorne, who had made “many short trips during the summer” and at the end of September 1906 “recently” had added the Weeber device to his ten-horsepower Maxwell.²²¹ In October 1906, *The Argus* reported that Parker Corning, “who recently purchased a Peerless touring

car, is having the Weeber shock reliever placed on the machine.”²²²

Several testimonial letters regarding the shock reliever date from November 1906. Many of these letters were reproduced as stereotypes (printing plates) for use in advertising. One assumes that Weeber or Fletcher Battershall solicited these letters.

Archland M. Dederick, of the Dederick Agricultural and Machine Works in Albany, wrote that the “Shock Relievers having been on my 1904 Franklin some months have proved all your claims. . . .” The device “answers all purposes of such an attachment, besides being the lightest, simplest, and most durable with minimum amount of attention.”²²³ Also equipping a Franklin Model G and praising the shock reliever was Walter B. Stephens of Thomas Stephens & Sons, builders and real estate agents in Albany.²²⁴

Ludlow L. Melius wrote on the letterhead of the State Engineer and Surveyor:

Replying to yours of the 7th would say: I am only too glad to speak of the Weeber Shock Reliever as I found it.

My riding is mostly on the roads under construction by the State Engineering [sic] Department. These are very rough (as we always make them worse before we make them better) and almost impassable. Before I put your Shock Reliever on it was very hard at times to stay in the car during part of my inspection.

Since I have the Relievers on, my Maxwell takes me with comfort and pleasure. I have no more broken springs and the back wheels stay on the ground, a result of great saving to back tires.

From personal inspection I believe the Weeber Shock Reliever is the most perfect reliever on the market today. They make rough pavements ride like Macadam.²²⁵

²¹⁹See below for mention of Weeber’s attendance at the Automobile Club of America’s December 1906 show at the Grand Central Palace as well as the January 1907 Seventh Annual National Automobile Show at Madison Square Garden. Weeber’s visit to the auto show at the Grand Central Palace in late 1907 also has been documented. See the discussion of auto lamps below in this work.

²²⁰*The Argus*, September 16, 1906.

²²¹*The Argus*, September 23, 1906.

²²²October 21, 1906. Corning (1874-1943) was a member of Congress from 1923 to 1937.

²²³A.M. Dederick to C. F. Weeber Mfg Works, November 19, 1906.

²²⁴Stephens’ letter is dated November 10, 1906.

²²⁵L.L. Melius to C.F. Weeber Mfg. Works, November 17, 1906. Melius’ letter below his signature continues with his title, “Engineer in charge of Construction of Good Roads, N.Y. State Eng. Dept.” The 1906 *Report of the State Engineer* lists Melius as engineer in charge of several highway projects in the “Eastern Division: Highways.”

George A. Davidson of the Diamond Rubber Company in New York City wrote about the use of the shock absorbers on his White: "Wish to advise you, they are satisfactory in every respect. I used them for three weeks through muddy weather; they being at all times covered with mud, which did not have any effect upon their operating successfully at all times."²²⁶

Commission broker J. [John] L. Mallett of Albany had shock relievers installed on his twenty-four horsepower Peerless in the spring of 1906 and thereafter could "make much better time on rough roads with more comfort, and feeling of security against accident than formerly, and consider it absolutely indispensable."²²⁷

Alexander Anderson, general manager of the Albany Electric Illuminating Company, thought:

It pleases me to advise you that they do all you claim for them. I consider them a very important adjunct to an electric auto, as they stop spilling solution, and breaking of plates, from bumping over rough streets. They also increase the mileage per charge for the above reason. From a mechanical standpoint, I consider your shock reliever the only correctly designed thing of the kind, which has come to my notice; it's always in adjustment.²²⁸

Perhaps the most interesting testimonial letter of all came from the inventor of the shock reliever, Fletcher Battershall. The letter survives in the Weeber collection at the New York State Museum in the form of an unfortunately deteriorating advertising cut.²²⁹ In his letter, Battershall made no mention of his involvement with the development of the shock absorber or any business dealings with Christian Weeber.

Law Offices
Fletcher W. Battershall
Albany, N.Y.
100 State Street
November 21st, 1906
C. F. Weeber Manufacturing Works,
170 Central Avenue, Albany, N.Y.

²²⁶George A. Davidson to C. F. Weeber Mfg. Works, November 20, 1906.

²²⁷Mallett's letter is dated November 17, 1906. The Albany city directory for 1906 lists John L. Mallett as a broker at 423 Broadway.

²²⁸A. Anderson to C. F. Weeber Mfg. Co., November 20, 1906.

²²⁹H-1933.6.743-746.

Gentlemen:

Having had my Maxwell car equipped at the beginning of the season with one of the first sets of shock relievers put out by you, I desire to state the results of a test of about five thousand miles which included several tours over mountainous country.

From the beginning there was a remarkable change for the better in the riding qualities of the car and a decided increase in the speed which one could make over the rough roads without rocking the car. During the season I have neither bent nor broken a spring or any part of the running gear.

The results of your shock reliever were especially marked in touring on rutted roads where side swaying puts a severe strain on a device of this nature. The flexible blade treats this emergency perfectly and there has been no measurable loosening of the attachments, and everything seems to be in as good condition as at the beginning. Moreover there is no visible wear on the leather friction surfaces contrary to expectations. They have not worn away during the season more than the thickness of a piece of paper and at the rate the leathers promised to out last two more seasons.

Very truly yours,

Fletcher W Battershall

The Weeber Shock Reliever was promoted in small display advertisements in the trade press. For example, in the September 1906 issue of *Motor*, a 1/64th page illustrated insert claimed absolute satisfaction or "We will refund the money." "Special relievers [were] now on hand to fit all prominent cars."²³⁰

In January 1907, a 1/16th page advertisement in *Motor* claimed a one-year guarantee as well as a thirty-day trial. Two relievers were \$16.50; four at \$30; and four for heavy cars and trucks for \$40. "On account of the inability to secure space at the Central Palace Show, New York, we will exhibit in store almost opposite entrance." An advertisement

²³⁰An October 1908 advertisement was of similar size. Interestingly, an identically sized, nearby advertisement by the Thomas Spring Works of Canisteo for its shock absorber praised the, by twenty-first century standards, unfortunately named "Thomas Uphrow Cushion" ("stops upthrow without jolt or jar, upon a coil spring").

in the next month's edition noted that the relievers would "prevent breaking of springs and other working parts that would be affected by violent slings of body as well as add comfort to riding." Black finish was standard with nickel and polished brass available "at slight extra cost."

A general and widely distributed auto parts catalogue, the Post & Lester Company's *Motor Car Supplies 1907*, was marked on the inside cover by the Hartford, Connecticut, firm that "We Sell the Trade Only." Included among three pages of shock absorbers was the Weeber Shock Reliever. Occupying 2/5 of a page, the Weeber data included two cuts and extensive information about the shock relievers. Prices are given for sets of four at \$30 and \$40. The Post & Lester book also shows "the cleverest little tool for garage or owner for taking out valve springs." The Weeber Valve Lifter listed at \$2.50. "Every car should have one of these tools in its tool outfit." A separate "Confidential Rock Bottom [Post & Lester trade] Price List" gives the shock reliever prices as \$20 to \$26.65 and the valve tool at \$1.75.²³¹

A large scale purchaser of Weeber shock absorbers was the Baker Motor-Vehicle Company in Cleveland, a manufacturer of electric automobiles, in fact, one of the more successful makers of such cars. A letter to the Weeber Manufacturing Works from October 1907 indicates a continuing demand for shock absorbers. Specifically, Baker wished:

...to get ahold [sic] of ten sets of shock absorbers, same as the last ones furnished us. We are enclosing blue print, that there may be no error in same. In this connections, before placing an order, would ask if you can not give us a better price on these in lots of ten. Would also say that we have adopted these shock absorbers as regular equipment on these Roadster cars. While we do not build them in any quantity, yet we now have several out with your absorbers on and this next lot of ten will be entirely equipped with same.²³²

On December 3, 1907, C. H. Warren for the Baker Company wrote to ask for "about a dozen of your coil springs which go on the shock absorbers you have recently furnished us. We are having a little trouble with their breaking and getting lost."

²³¹H-1933.6.314.

²³²C. H. Warren for the Baker Motor-Vehicle Company to C. F. Weeber Mfg. Works, October 8, 1907.

Weeber noted on the letter that he answered and shipped on December 4, an indication of the speed with which letters were delivered by the post office. A final Baker letter, from April 23, 1908, was a cover for "our check for \$189.00 in settlement of your account in full date."²³³ A blueprint drawing of the "Relation of Spring to Body Roadster" in the Weeber collection at the New York State Museum attests to further business with the Baker Motor-Vehicle Company. While the print for the "Models M" is dated March 14, 1907, Weeber marked the reverse in pencil, "Rec [received] 6/19/08."

Fletcher Williams Battershall (1866-1929) was at times a lawyer, teacher, court reporter, assistant in the state engineer's office, book binder, wood carver, author and inventor. Among his patented inventions are a protractor (1908); an improved means of developing photographic film (1912); a photographic film apparatus (1915); a "resilient tire" (1917); and the Weeber shock reliever (April 16, 1907). The last was assigned patent number 850,460 after consideration of a patent application filed on February 10, 1906.

Among Battershall's published works are *The Law of Domestic Relations in the State of New York* (1910), *Bookbinding for Bibliophiles* (1905); *A Daughter of This World* (1893); and *Mists* (1894). A biographer (1911) said Battershall, "takes pleasure in automobiling, and is a lover of dogs. His close friends are those of intellectual attainments. He is fond of travel and has made several trips abroad, especially visiting art centers."²³⁴ Battershall was ac-

²³³R. C. Norton, secretary and treasurer for the Baker firm, to C. F. Weeber Mfg. Works, April 23, 1908.

²³⁴Cuyler Reynolds, *Hudson-Mohawk Genealogical and Family Memoirs* (New York: Lewis Historical Publishing Company, 1911), vol. 1, p. 219. Battershall attended Cornell University for two years before taking a position with the state engineer in Albany. He then turned to law, being graduated from the Albany Law School in 1896. For many years he was a lecturer at the school. And he served as deputy Supreme Court reporter in addition to maintaining a practice at 100 State Street. His first wife, Maude G. Fiero, was the daughter of the Albany Law School dean James N. Fiero, also Battershall's law partner. Battershall's father, Walton W. Battershall, was rector at St. Peter's Episcopal Church in Albany. The reader will recall that Fletcher Battershall himself recorded his penchant for motoring in the testimonial letter sent to the Weeber Manufacturing Works about the Weeber Shock Reliever. In that letter, reproduced above, Battershall mentioned having driven 5,000 miles in 1905, an impressive figure given the limitations on

SHOCK ABSORBERS.

Weeber Shock Relievers.

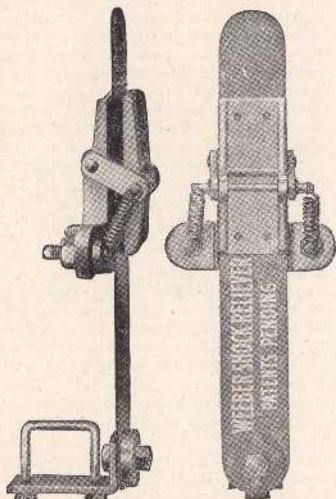

This new and efficient device has been brought on the market to fill the long-felt want for a shock-relieving device that is not costly, will not rattle, and at the same time take up wear automatically and do the required work without affecting the easy riding qualities of the springs. It will let springs have free movement while running over smooth roads, and will only act when rebounds take place. The more violent, the tighter the shoe will grip.

The manner in which these Relievers are fastened to car is another point in their favor.

With most similar devices it is necessary to move guard irons or some other thing in order to apply to axle. With the Weeber device this is not necessary, as it can be applied to semielliptic spring, to either side of spring seat, and to the full elliptic spring; can be fastened to top and bottom of spring itself.

Several styles of lower fasteners are used to facilitate the particular type of car. The one shown on cut is used for elliptic and where spring is flush with frame.

Prices.

Sets of 4 for Runabouts or Touring Cars,	\$30.00
Half Sets sold for rear,	16.50
Sets of 4 for Trucks and extra heavy Touring Cars, ...	40.00

Finished in Black.

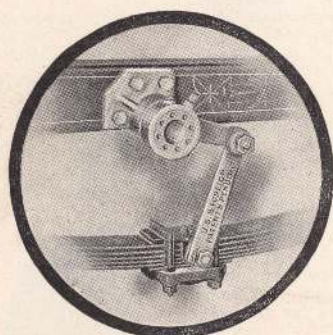

Sager Equalizing Springs

Act as compression.
 A tension spring and shock absorber.
 No working joints.
 No frictions.
 Prevents rebounds and saves springs.
 A very satisfactory shock absorber for low price.

Price, \$30 per set, \$15 per pair.

Price includes crucible springs and all other parts for attaching. In ordering it is necessary to give us name of car, model of car, year made.

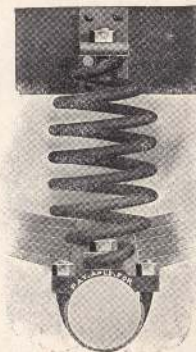

The Diezemann Shock Absorber

Retards sudden or violent movements of the springs and axle in relation to the car, by a fibre friction disc arrangement which takes up the shocks. Degree of friction resistance is adjustable, and, once adjusted, the device needs no further attention of any kind.

Large Set of 4 (for cars over 1800 lbs.).....	\$60.00
Small Set of 4 (for cars under 1800 lbs.).....	45.00
Fittings per set extra,.....	8.00

The Baldwin 1907 Spring Recoil Check.

This is a very satisfactory device to supplement the control of the recoil of springs on automobiles. It permits free compression of the springs, but gradually checks the recoil so that in fast riding the occupants can keep their seats. It is easy to attach, requires no oiling nor adjusting after attachment. All parts are guaranteed for one year.

Price \$60.00 for a Set of Four.



Shows attached to car

Figure 4.10: Weeber Shock Reliever presented in the wholesale Post & Lester Motor Car Supplies Catalogue, 1907. The text notes the shock absorbers were “Finished in Black.” NYSM Collection, H-1933.6.193.

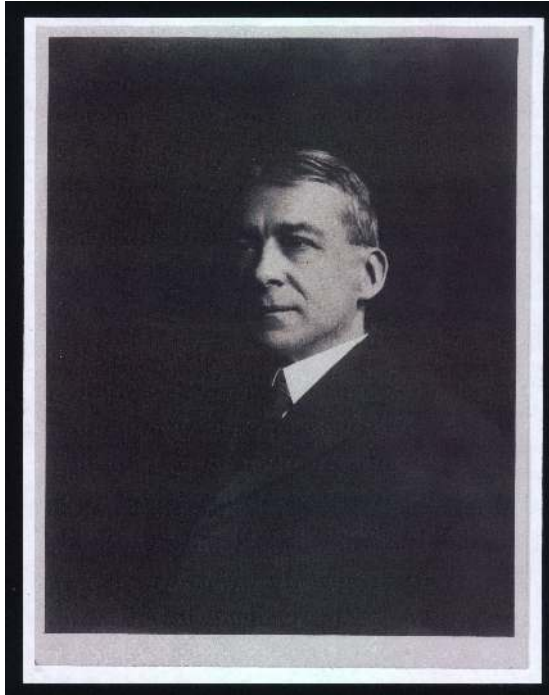

Figure 4.11: Fletcher W. Battershall, c. 1915. NYSM Collection, H-2000.39.NN.



Figure 4.12: Fletcher W. Battershall, c. 1925. NYSM Collection, H-2000.39.NN.

tive in the affairs of the Albany Automobile Club, for example, as a member of the tour committee, which in 1909 organized a seven-day pleasure run for New England members.²³⁵

In 1906 when Christian Weeber was a Maxwell agent, Battershall, as previously shown, drove a Maxwell and in 1908, when Christian Weeber was a Ford agent, Battershall operated a Ford Run-about. Both Battershall and Weeber were members of the Albany Automobile Club.²³⁶ A January 10, 1906, copy of *The Horseless Age* in the Weeber collection at the New York State Museum is marked in pencil, "Property of Mr. F. Battershall." In short, given the intimacy of the automobile world in Albany, it's likely that the two men were well acquainted by the mid-1900s. Battershall's close association with Christian Weeber is demonstrated further by a short item in *The Argus* in September 1906.

Hon. J. Newton Fiero and Mr. Fletcher W. Battershall, who left last week in Mr. Battershall's Maxwell car for Portland, Me., had a very successful journey. The machine was newly equipped with the Weeber "shock reliever" and the other inventions of Mr. Weeber.²³⁷

A comparison of the Battershall shock absorber patent drawing and the Weeber shock reliever shows that for practical purposes, the two are identical. The first drawing from the Battershall patent has the frame of the car identified with an "X" and the spring with a "Y." "H" is the sliding member gripped by the device whose components are labeled with the remaining letters. The drawing of the "Weeber Shock Reliever" has the very same parts as the Battershall, although rearranged

auto use presented by the seasonal limitations of the cars and the roads. Sometime in the 1920s Battershall left Albany for New York City, where he died in 1929.

²³⁵For details of the run, see the *Albany Evening Journal*, April 3, 1909 and June 12, 1909.

²³⁶A list of club members was printed in *The Argus*, April 28, 1907. Other names include those of Weeber's business partner W. J. Sutherland and many of the customers for Ford cars, e.g., H. C. Abrams, Walter L. Palmer, Archland Dederick, Charles L. A. Whitney, G. A. Hubbard and H. M. Sage. *The Argus* for August 11, 1907, reported that Battershall was a member of the Albany club's law committee. The newspaper for April 4, 1908, which reported that Weeber "and party" had driven to the Briarcliff (Westchester County) road races, noted that "Mr. Fletcher Battershall and party" also were part of the Albany contingent.

²³⁷September 26, 1906. Fiero was Battershall's father-in-law.

for the absorber to be mounted below the spring rather than above.

Four third-party letters to Battershall preserved in the Weeber collection at the New York State Museum refer to the manufacture and sale of the shock absorber. The letters, dated only by month and day but probably written in the 1908 period, were sent to Battershall by William Lawton, proprietor of the Kingston Foundry Company. He probably was the son of William Lawton (1829-1893), a lawyer and county judge who, in 1879, "organized a company for manufacturing purposes and built a large factory near the West Shore" railroad employing (1896) several hundred people.²³⁸ The tenor of the younger Lawton's writing suggests the shock absorber as being marketed by Weeber was flawed and was not selling well. Lawton on March 23 claimed that:

Last year I did a great deal of missionary work on the shock absorbers and developed the idea to a good working device.

I also acquired a great deal of information as to marketing them &c.

I would like either to sell what I have or make an arrangement with you to continue to handle them.

Your patent seems to be the same idea and I can not see why the Patent Office grants 2 patents on the same thing.²³⁹

I have a well equipped machine shop for manufacturing.

On March 23, Lawton continued:

My experience with the shock absorber has been unfortunate and I lost several thousand dollars last year.

²³⁸J. H. Beers and Company, *Commemorative Record of Ulster County* (Chicago, 1896), pp. 18ff. If the younger William Lawton referred literally to thirty years' experience in manufacturing and selling and he started with the Kingston Foundry in 1879, then his letters would date from 1909.

²³⁹The author does not know to which other patent Lawton referred. A check of patents granted for shock absorbers shows none in 1904 or 1905; four in 1906; eight in 1907, including Battershall's; thirteen in 1908; twenty in 1909; and twenty in 1910. Some of these shock absorbers were meant for use on bicycles but most had applications for automobiles and/or carriages. Many of the absorbers were the friction type like Battershall's. Others utilized springs or hydraulic mechanisms. From the author's quick check, patent 930,498, granted to George E. Shippey of Pittsfield, Massachusetts, on August 10, 1910 (after an application filed July 22, 1908) is closest in principle to Battershall's.

I pushed it pretty hard but did not throw away any money needlessly as I have had 30 years experience in manufacturing & selling. There are several serious draw backs to the shock absorber. One is that it requires attention on the part of the owner—the shoes are lined with leather which has to be occasionally oiled... The attachment is another difficulty. Cars are now made with a long overhang of the car body and I had to discard the clamp you are using as it clamps the springs and limits their action. I improved considerably on this...

The most serious difficulty is the selling. In no case has the sale of one set brought about the sale of another.

This makes the selling a dead drag for each order and causes very heavy selling expense. Many sales have cost the price I get for the goods. I figure each inquiry costs about \$300 and converting 20% of inquiries into orders is good work. The cantilever springs have come along to limit the business as they do not need shock absorbers and they can not be attached to I think this will be the spring universally used.

My design has been more carefully worked out than yours and they are nicked and polished all over making them very attractive in appearance. The workmanship is good and they ought to sell, but as stated above sales are very difficult.

But I do not like giving it up yet as I have considerable stock on hand and have done a great deal of preliminary work and have attained considerable knowledge of the business.

Would you care to give me a copy of your contract with the Weeber Co? Judging from their circulars I do not think that they understand the selling game. As they are not doing anything with it perhaps they would release you on your contract.

Kindly see what you can do in this direction and let me hear from you as soon as possible.

I had planned to do some business this spring...

It seems as though we ought to be able to arrange something to mutual advantage.

The third of the three Lawton letters is dated April 6:

Will you kindly reply to my last letter?

I had planned to give the shock absorber another year's trial. As I wrote you I lost considerable money last year.

I realize by experience that this shock absorber has considerable to contend with and whether it will win out in the end is a matter of experience.

As you are doing nothing with it I think it would be better to let me try it out to a finish.

I don't think there is any chance for the parties who now have it as I do not think they understand selling goods of this kind. I am judging from the circular sent me.

I have a number of inquiries and would like to make some kind of an arrangement by which I can carry on the business.

Spring is the season in this line of goods. Kindly let me hear from you.

The fourth Lawton letter is printed here in full. Suggesting that the arrangement with Weeber was at an end, the letter indicates that Battershall had offered to sell the shock absorber patent to Lawton.

Yours recd—I would not care to make an offer for the patent at present. There may be other uses for it but I have not thought of any after 1½ years experience with it and I have had 35 years experience around machinery.

I would like to try it out for another year—I was working on a royalty and would like to have you make me a royalty proposition.

Have you sold the patent to Mr. Weeber? Can you suggest any way by which I might go on with it except by purchase.

The Cantilever springs, the care called for by the car owner, the difficulty in attaching to different makes of cars and my experience in the cost of making sales all deter me from an offer to buy.

Yet I might be wrong and the only way to know is by a further trial. Last year's experience ought to help some.

I hope you will let me know promptly as this is the season to sell shock absorbers.²⁴⁰

With the apparent end of the shock absorber business, Fletcher Battershall sought to develop another of his automotive inventions. In 1912, *The Knickerbocker Press* reported the following:

²⁴⁰Lawton to Battershall, April 10 (year not specified).

A more recent concern [than the C. F. Weeber Manufacturing Works] is the F. W. Battershall Company, manufacturers of the thermo gasket [sic]. Mr. Battershall is a lawyer and lectures at the Albany Law School, but in his spare moments he has found time to devise a contrivance that is a great aid to the evaporation of gasoline and increases the mileage of a car, reducing the cost of fuel and makes the engine respond quicker in the cold weather. He has secured a New York concern to put the invention on the market.²⁴¹

Interestingly, a few years later Christian Weeber developed a fuel transforming device that promised better engine efficiency and performance. Discussion of the Weeber invention follows in a separate section of this book. Here one might wonder about possible Weeber-Battershall conversations in the 1910 period regarding improvements in internal combustion engine fuel systems.

The Worcester Pressed Steel Company of Worcester, Massachusetts wrote the Weeber Manufacturing Works on May 27, 1909 about "Pressed Steel Shock Absorber Parts." Other than the usual oval pencil marking acknowledging that he had read the offer, Christian Weeber recorded no comment on the Worcester letter, which reads, in part:

We are interested in your shock absorbers from a manufacturer's standpoint and if you buy parts outside we solicit your inquiries and orders in our line.

...We manufacture many metal stampings and drawings special to our customers' designs and would be please to quote you interesting prices on any samples or detailed drawings you will submit, informing us the quantity desired, provided there is an opportunity for us to get the work. Our prices depend largely upon quantity ordered.

We make a specialty of replacing drop forgings with PRESSED STEEL which is lighter, stronger, and, in many cases, better and cheaper. We weld steel and other metals by the new Autogenous welding process which largely increased the range of PRESSED STEEL.

²⁴¹February 11, 1912. The corporations unit in the Secretary of State's office reports no record of incorporation for a Battershall company.

... We solicit problems requiring judgment, skill and science, practical and technical experience, and may be able to offer suggestions of value to you.

P.S. We could roll our own steel.²⁴²

Certainly, fitting the shock absorbers was a challenge as shown by letters addressed to the Weeber firm by purchasers. Anthony H. Wilson, apparently a Cadillac agent²⁴³ in Canton, Ohio, was, however, generally pleased with them. The earliest surviving letter, March 19, 1908, was an order of shock absorbers for the rear axle of a Model H Cadillac. Weeber marked on the Wilson letter, "Wrote for dimensions 3/24" as well as "Expect to ship within a few days Shipped 4/2/08." In a follow up letter on March 28, Wilson mentioned that he had "sent you a cut marked, that was all that was necessary and you would not hold us up waiting." In fact a page from a Cadillac catalogue showing the rear wheel and spring marked with an "x" survives in the Weeber collection at the New York State Museum. In any case, in his second letter, Wilson sent Weeber dimensions of the spring.

On April 4, 1908, Wilson wrote that he had installed the shock relieves and "wish to say I think they are fine. Please ship another set for a Model G Cadillac at once. Cut of rear spring enclosed." In fact, a page from another catalogue is pinned to Wilson's letter. Weeber marked this letter "Arr [arrived] 4/6 Ans. 4/9 Sent 4/9."

On April 14, 1908, Wilson, with a check enclosed, wrote regarding the order of shock absorbers for the Model G and Weeber's invoice. Wilson noted that he had ordered two sets of Model "B" shock relieves but received only one set. "... if you will send us another set charges prepaid, kindly do so at once." The carbon copy of Weeber's reply is one of his few outgoing letters in the Weeber collection at the State Museum. As such, it is copied here as an example of Christian Weeber's business communications.

ALBANY, N.Y. 4/15/08

Mr. A. Wilson

Canton, Ohio

Dear Sir:

²⁴²F. C. Cutler, sales manager, to C. F. Weeber Mfg. Works, May 27, 1909.

²⁴³His letterhead notes he was a dealer in automobiles and supplies as well as bicycles and sporting goods.

We are in receipt of your favor of the 14th. And also check for \$22.64 for which accept our thanks. We regret that we did not send you the two sets or four Model "B" Shock Relievers for Model "G" Cadillac, as desired, but in looking over your letter, we note the error was on your part, as it stated: "Ship on another Set for Model "G" Cadillac." We should be pleased to send two more immediately, charges prepaid.

Trusting this is satisfactory, and thanking you again for your kindness in the matter, we are,

Yours respectfully,

C. F. WEEBER MFG. WORKS.

PER [CFWeeber penciled signature]

Wilson wrote on the Weeber letter, which was returned to the Weeber Manufacturing Company, "Please ship two more relieves for rear of Model 'G' Cadillac as mentioned above." And Weeber noted, "Ans. 4/20."

The last Wilson letter dates from April 22, 1908. In it he orders yet "another set of two for Model 'G' Cadillac car as soon as possible rear springs." Weeber noted "Ans. 4/23 Prom to ship in a few days."

Another buyer of multiple sets of shock absorbers was Henry W. Randall, whose letterhead was that of the Saginaw Coal Company in Saginaw, Michigan.²⁴⁴ His order on March 18, 1908, was for the two pair for a 1908 Packard. "Kindly ship as soon as possible, as we want to get these on the machine. Expect to sell quite a number in Saginaw and Bay City during the season."

Weeber wrote on the Randall letter, "Same as 1907" and "Cancelled." The reason for the latter notation is a Randall letter from March 19, 1908, substituted from an order of one pair of shock absorbers for two. Weeber noted that the items were "Shipped 3/26 AM."

Over a year later, on August 18, 1909, Randall wrote to order four shock relieves for a Model 17 Buick, specifically Model "A" Relievers for a two-inch front spring and two Model "B" relieves for 1.75 inch rear spring. Weeber noted these were shipped on August 23.

Finally, on August 30, 1909, Randall ordered four relieves for an Oakland Model 40 roadster. They were sent on September 4, 1909.

²⁴⁴The letterhead lists Robert M. Randall as general manager of the coal company, "Miners and Shippers of Bituminous Coal."

A query regarding the Weeber shock absorber in April 1908 came from Harry Ainsworth, secretary of Williams, White & Co., dealers in machinery and coal chutes in Moline, Illinois. In response to an advertisement, they wanted “further information and price for a touring car weighing about 3100# without passengers.” In 1909, a request for information about shock absorbers for a 1909 Elmore came from Bridesburg, Pennsylvania. Another request came from Meriden, Connecticut, without specifying a make or model.

A dissatisfied purchaser of shock absorbers was the Mobile Auto Company in Mobile, Alabama, agents for Stoddard-Dayton cars.

Enclosed please find B/L [bill of lading] for Shock Absorbers shipped you to-day. We tried several times to install these Shock Absorbers but every time found that they would not fit, so we are returning same for credit.²⁴⁵

Among the shock reliever materials preserved by the Weeber family is a one-page undated broadside. It was distributed by the Hartford Suspension Company of Jersey City, New Jersey, makers of the Truffault-Hartford shock absorber, a widely used French design. The document, with a “Warning” title, claims the company’s patent, reissue 12,437, “covers broadly all successful types of friction suspension devices, and all Shock Absorbers of this type on the market, other than Truffault-Hartford, are infringements. . . . We intend that our rights shall be respected, and hereby give notice that we shall proceed to enforce the same against all infringers, whether manufacturers, dealers, or users. . . .”²⁴⁶ Christian Weeber’s pencil mark attests to his having read the statement. Whether he or Battershall took any action because of the broadside is unknown here. Also among the artifacts of the Weeber estate is a Hartford Suspension adver-

²⁴⁵M. Kimbrough for the Mobile Auto Company to C. F. Weeber Mfg. Works, May 15, 1909. At about this same time, the Taxi Motor Cab Company of Boston paid the Weeber Manufacturing Works for an unidentified purchase, perhaps shock absorbers or perhaps another Weeber product. A letter dated May 12, 1909, and signed by William P. Barnhart, manager of the taxi company, mentions only an enclosed check for “payment of the attached bill.” Apparently the bill has not survived among Weeber documents. The letter is H-2000.39.

²⁴⁶The original patent granted to Jules Michel Marie Truffault, a French engineer, is numbered 695,508 and dated March 18, 1902.

tising magazine called *Auto Comfort* from March 1909.²⁴⁷

The Albany city directory for 1911, probably published about July 1, 1911, contains a display advertisement for the C. F. Weeber Manufacturing Works. The text notes that the Weeber firm was the maker of the Weeber muffler, “Shock Relievers and Valve Tools and other Weeber Specialties.” Apparently, then, the shock reliever was being marketed as late as mid-1911.

A brochure and handbill in the Weeber collection at the New York State Museum for the Diezemann shock absorber suggest that Christian Weeber kept himself apprised of competing shock absorbers on the market. Made by the Diezemann Shock Absorber Company of Hoboken, New Jersey and in use by 1906, the Diezemann, like the Weeber shock reliever, was a friction-type device that could be “applied in any position to the inside or outside of the frame of any type of car” and be inverted without affecting “the action of the device.” Supposedly unlike other shock absorbers, the Diezemann was self-lubricating. A set of four Diezemann absorbers cost \$35 or \$60, depending on the weight of the car. With fittings it was \$4 more.²⁴⁸

Among the documents in the Weeber collection at the museum is a booklet describing the Graygood hydraulic shock absorber. This double-acting device, similar to those eventually standard on twentieth-century automobiles, was manufactured by Graham & Goodman, who had offices on W. 93rd Street in Manhattan. The cost for a set of four was \$75.²⁴⁹ A *Ford Accessories* catalogue for 1907, when Christian Weeber was a Ford agent, shows what appears to be a pneumatic shock absorber costing \$40 “per set.”²⁵⁰ A friction-type shock absorber of the mid- to late 1910s utilizing a spring

²⁴⁷Vol. II, No. 6. “A Periodical for Motorists Subscription Price. Nothing” H-1933.6.347.

²⁴⁸The handbill is not dated. The brochure, H-1933.6.301, contains testimonial letters dating from December 1905 through July 1906. A display advertisement for Diezemann’s Shock Absorbers appears in the January 10, 1906, edition of *The Horseless Age*. Gustav Diezemann of West Hoboken was granted a patent, 840,049, for a “suspension device for vehicles” on January 1, 1907, following an April 3, 1905 application.

²⁴⁹The booklet, H-1933.6.315, is not dated. An automobile appearing in a photo on the last page probably dates from about 1909.

²⁵⁰The descriptive text reads, “As we have had considerable call for Shock Absorbers to be place on our cars, we have decided to carry a few sets in stock for the accommodation of our

and coiled belting was the Gabriel Snubber, the product of the Gabriel Manufacturing Company of Cleveland, Ohio. The Weeber collection has a Gabriel Snubber handbill stamped with the name of Wm. H. Sheehey, apparently a dealer at 131 Hudson Avenue in Albany.²⁵¹ It's likely that the Weeber shock reliever was out of production at the time this flyer reached Christian Weeber.

Wheel Puller

Even in his role as a Ford dealer in 1907, Christian Weeber continued to enjoy the benefits of the product development that pre-dated his association with the Ford Motor Company. In December 1907, Gaston Plantiff, manager of the Ford branch in New York City, wrote to Weeber asking him to send "one of your wheel pullers suitable for a Model S" Ford to the Ford agent for Montgomery and Fulton counties, J. W. Sisson of Gloversville. The latter had "ordered this wheel-puller of us but it will save both time and expressage to have you deal with him direct." Weeber noted on the letter that he had contacted both Sisson and the Ford Company as well as shipped the puller.²⁵²

Next, Weeber apparently offered Plantiff a quantity of wheel pullers with a "liberal discount." Plantiff, in acknowledging Weeber's letter of December 9, 1907, replied by noting that "it is becoming more and more the policy of the Company to deal strictly in automobiles and not carry accessories in stock to any extent. We will undoubtedly receive a number of requests for wheel pullers and shall be very pleased to turn all orders over to you to ship direct and in this way you will make a larger profit."²⁵³

A few days later, Plantiff wrote to Weeber about testimonials. He said that the Ford factory had warned:

... all branch managers against giving lists of customers or agents and against writing any

customers." The catalogue has accessories for Ford models K, N and R. H-1933.6.299.

²⁵¹H-1933.6.303. Prices for four Snubbers ran from \$18 to \$36 depending upon car or truck weight. The Gabriel handbill also advertises the Gabriel Wind Shield Cleaner, a \$2, hand-operated windshield wiper.

²⁵²Plantiff to Weeber, December 7, 1907.

²⁵³Plantiff to Weeber, December 11, 1907. This letter survives in photocopy form received with the bequest of Marion Weeber.

testimonials recommending any accessory or oil. This will not prevent us, however, from telling our agents and friends of the good qualities of your wheel-puller if they come to us for information.²⁵⁴

Another automobile manufacturing customer for the wheel puller was the Selden Motor Vehicle Company of Rochester. George B. Selden, president of the company, of course, was the claimed patentee of the automobile. Efforts to enforce the 1895 patent divided the automobile industry, with some manufacturers paying royalties and some refusing until 1911.²⁵⁵ The Selden car, however, was new for the 1908 model year as E. T. Birdsall, engineer for the car, wrote to request "by express to our factory 72 North Avenue, this city, one of your wheel pullers and render us bill for the same, less the usual trade discount."²⁵⁶ Weeber marked the Birdsall letter "Shipped 11/29" and "Ans. 11/30."

On a proof for a C. F. Weeber Manufacturing Works wheel puller advertisement scheduled for the August 2, 1908 issue of *The Automobile*, someone has marked in pencil, "leave out as" (the last word in a circle). Someone has indicated in red ink the omission of a "so." Weeber has marked the proof "OK CFWeeber."

The printed text of the advertisement describes the utility of the wheel puller "for factory or repair shop" in removing wheels without damaging the wheel, axle or bearings. The sentence affected by the deletions reads, as set in the proof, "... the grip is spread so uniformly around the wheel so as to make it impossible to injure wheel or finish." The price of the puller, incidentally, was \$16.50 with a special size to fit a large hub made to order at no extra cost.

Motor, in its "New Things for the Motorist" section in December 1907, described the Weeber Wheel Puller useful in removing a rear wheel "put on so tightly it is difficult to get it off." By lacing the device to the spokes and then turning three screws, "the wheel will be drawn off the shaft, however

²⁵⁴Plantiff to Weeber, December 18, 1907.

²⁵⁵Association of Licensed Automobile Manufacturers, *Handbook of Gasoline Automobiles* (New York, 1906), p. 8. "The Commissioner of Patents in his annual report for the year 1895, said: '...Selden...patent...No. 549,160...may be considered the pioneer invention in the application of the compression gas engine to road or horseless carriage use.'"

²⁵⁶Birdsall to C. F. Weeber [sic] Mfg. Works, November 25, 1907. Kimes and Clark, p. 1337, credit Birdsall with several car designs.

It Does the Work Quickly and with Ease



A Strong Pull without Injury to Wheel, Axle or Paint

WEEBER WHEEL PULLER

The Most Useful Tool for Factory or Repair Shop

The above tool has been designed after many years' experience removing rear wheels from automobiles. This has always been a very difficult task, so as not to injure wheel, axle or bearings.

The Puller is quickly laced firm to wheel, thereby avoiding the temptation of the workman using the sledge, which has ruined so many wheels and axles, and if very tight would be impossible to remove, as the axle would upset and get still tighter. With the WEEBER DEVICE this is all avoided, as the pressure is so strong and steady that the tightest of wheels will be removed without injury to end of axle, and the grip is spread so uniformly around wheel so as to make it impossible to injure wheel or finish. It can be laced to wheels with any number of spokes, and close brake drums will not interfere. The Puller is built strong and is also useful to remove fly wheels and many other parts where it is possible to lace to. Finish will be black, and have padding in place to prevent injury to paint when applied to wheel.

One Puller to fit all size wheels, \$16.50. Special size to fit over extra large hub, made to order without extra cost.

C. F. WEEBER MFG. WORKS
ALBANY, N. Y.

1907

Figure 4.13: Proof sheet with Weeber Manufacturing Works corrections for a wheel puller advertisement in *The Automobile*, August 2, 1908. NYSM Collection, H-1970.110.8.

tightly it may have been forced on. The puller is made to fit all size wheels and sells for \$16.50." A display ad in the February 1908 *Motor* included a cut of a wheel with the puller attached. The tire had been lettered "WEEBER WHEEL PULLER PATENT APPLIED FOR." The text notes, "We are also the manufacturers of the Weeber Shock Reliever, Valve Tool and Muffler." Additional advertisements for the Weeber wheel puller appeared in the March, May, June and July 1908 editions of *Motor*.

Valve Tool

In February 1907, *The Horseless Age* announced the marketing of the C. F Weeber Manufacturing Company [sic] tool for removing valves. A description of the tool's operation concluded by noting that the device "is also handy in removing and placing tires and side rings in position, and in generally compressing or forcing parts together where clamps would ordinary [sic] be used."²⁵⁷

Motor for April 1907 also announced the Weeber valve tool in words similar but not identical to those of *The Horseless Age*. Advertisements for the \$2.50 valve tool ("one of the handiest tools for auto kit or shop") appeared in the February 1907 *Motor* and the *Automobile Dealer and Repairer* for the same month. Other *Motor* ads appeared from March through September 1907.

A patent application for the valve tool was filed on February 1, 1907. The patent was issued on May 28, 1907, as number 854,860 for an "engine valve tool" for valves keyed to valve stems. Weeber's claimed his invention provided better means for compressing the valve spring, holding the valve on its seat while the spring was being compressed and

²⁵⁷ "As will be seen, the tool consists of a flat steel bar A, which is so shaped that one end of it rests on top of the exhaust valve, while the long arm of it is in a vertical position on the outside of the cylinder. The lower end of the bar has a series of holes through it in which cotter pins can be placed that act as pivots for the lever B. A sliding collar C acts as a pawl in conjunction with the ratchet arrangement D, which is integral with the lever B. The inner end of the lever is forked so that it can be placed under the valve spring and retaining washer. Very slight pressure on the outer end of the lever forces the spring upward, at the same time pulling down on the bar A and holding the valve against lifting. The collar and ratchet retain the advantage gained and keep the spring compressed so that the valve key at E can be removed at leisure." *The Horseless Age*, vol. 19, no. 7, February 13, 1907.

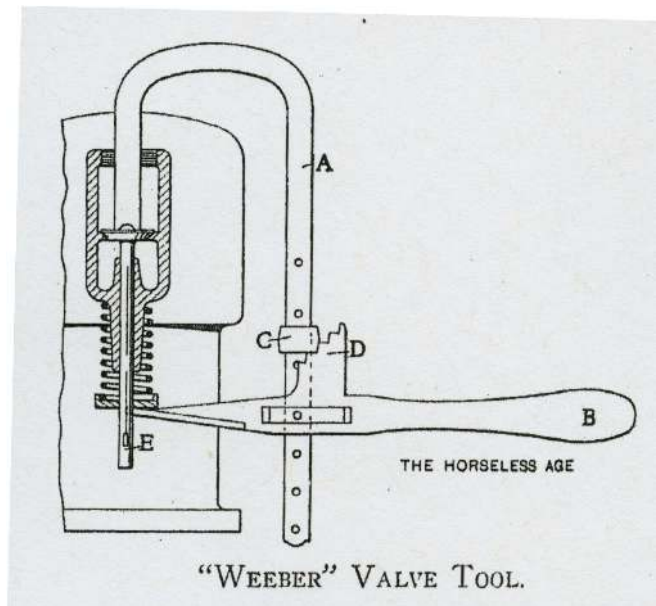

Figure 4.14: Weeber valve tool featured in *The Horseless Age*, February 1907. Courtesy of New York State Library, Manuscripts and Special Collections.

holding the spring "without maintaining a continuous pressure by hand." In mentioning other uses for the tool, Weeber said it could function as a "lever in many positions where a fulcrum for the lever is not ordinarily obtainable. For example, it may be used for removing or replacing pneumatic tires."

In March 1907, the Argus Company in Albany billed the Weeber Manufacturing Works \$7.50 for 3,000 "Valve Circulars." It's likely that Weeber advertised in trade journals in 1907 and 1908 given the evidence of preserved letters from potential distributors or sellers of the device. In October 1907, the Penn Auto Supply Company in Philadelphia, Pennsylvania, in response to Weeber's price quotation, wrote, "we have never carried a stock of these tools, and would like to take a trial order of one half dozen. . . If we find these tools will sell, we will hereafter order in dozen lots."²⁵⁸ In September 1907, Charles E. Miller, with the "Largest Assortment of Automobile and Cycle Material in U.S.," billed Weeber for "expressage on 1 Handle for Weeber Valve Tool (\$.25)."²⁵⁹ In January 1908, Miller, claiming to be the "Largest Autom-

²⁵⁸ G. L. Fischer for Penn Auto Supply Company to S. [sic] F. Weeber Mfg. Works, October 29, 1907.

²⁵⁹ Weeber has marked the invoice "Send Stamp for #1481." Perhaps Weeber had promised to send a handle at no cost for shipping and then billed for postage. The Miller invoice also

ble Supply House in America," in a letter ordered "by express 12 of your valve tools."²⁶⁰ The Miller firm wrote again in March to order another two dozen shipped by express.²⁶¹

On February 9, 1907, Miller billed Weeber \$.25 for "Expressage on 4 Electrotypes."²⁶² In late January 1908, the Times Square Automobile Company requested an "electro type and jobbers quotations on your valve lifters"²⁶³ and at the beginning of April asked, "what prices you will make for the season of 1908."²⁶⁴ Weeber noted, "Ans. 4/2 50-5%, 25 lots 50-10-5%."

Another New York City-based company requesting a quote was the Pierson Motor Supply Company. Using its standard preprinted request form for "best jobbing prices," the blank spot on the page was filled with "valve tools". Other parts of the letter asked for "descriptive pamphlets or other printed matter as you may issue." And the text noted that the Pierson Company had "two men out all year around more during the busy season. Covering all of New Jersey, part of New York State and "from Brooklyn, all of Long Island We are the only concern doing an exclusively jobbing business on Long Island."²⁶⁵ Weeber noted, "Ans. 3/25 50-5".

In response to Weeber's letter, Pierson replied:

We beg to acknowledge receipt of your favor the 3rd inst. in which you state that it would not be right for you to quote us your bottom price on a single tool. We recognize the fact that we would not be entitled to your bottom price on a single tool. If we handled your goods at all and found any sales for them we

is printed, "We Either Carry in Stock, Will Get It, or It Isn't Made."

²⁶⁰Charles E. Miller (rubber stamped signature) to Mess. C. F. Weeber Mfg. Co. [sic], January 11, 1908. Pencil notation on the Miller letter reads, "Ans. Shipped 1/13."

²⁶¹The letter is dated March 20, 1908. Weeber noted in pencil, "Ans. 3/21 Bill Sent 3/21."

²⁶²There is no description of the electrotypes on the invoice. They may be for objects other than the valve tool. Why Weeber was being billed for the shipping of the electrotypes is unknown here.

²⁶³E. J. Kestenbaum [illegible ?] for the Times Square Automobile Company to Weeber Manufacturing Company, January 28, 1908. The Times Square letterhead claimed to represent the "Largest Dealers & Brokers of Automobiles in the World."

²⁶⁴Kestenbaum of the Accessory Department to C. F. Weeber Mfg. Works, April 1, 1908.

²⁶⁵J. [illegible] Pierson to C.F. Weeber, March 24, 1906.

could probably sell 400 or 500 tools as we sell entirely to dealers.

We would neither catalog nor try to sell these goods unless we carried them in stock. We would not be interested in the price you quoted us but if you would make us a price which would enable us to sell these goods to dealers at a satisfactory margin of profit we would be glad to hear from you again.²⁶⁶

Still another New York City firm interested in the valve tool was the Universal Auto and Motor Boat Supply Company, which wrote in April 1908, for the "lowest jobbers price on you valve tool also if you will furnish us with a cut on same for our catalogue which is at present under construction."²⁶⁷ Weeber noted, "Ans. 4/8 V.T. 50-5%, 25 lots 50-10-5%." Universal wrote again to ask about a "cut of the Valve tool."²⁶⁸ Weeber wrote on the letter, "Ans. 4/14 Cut sent."

A valve tool inquiry came from R. S. Cheek, seller of Maxwell cars in Nashville, Tennessee, who asked for literature as well as "prices & terms to dealers."²⁶⁹ The Walla Walla Motor Car Company reported seeing an advertisement in the *Automobile* magazine of February 6, 1908, and requested a "more complete description of your valve grinding [sic] tool. Weeber's penciled notations quote discounts for four of his products—"Ans. 2/20 Puller 20% Muff 50% V.T. [valve tool] 30 S.R. [shock reliever] 30%."²⁷⁰ The Angier Company in Boston wrote to ask for "jobbers' price on the Webber [sic] Valve Tool."²⁷¹ Weeber's reply in pencil notation indicated, "VT 50-5% 3/24."

Universal Motor Imports, Ltd. in London wrote in January 1908:

We shall esteem it a favour if you will kindly send us illustrations and best possible prices for your Valve Removers for petrol motors. At the same time you may let us know if you are in a position to appoint us exclusive

²⁶⁶Pierson to C. F. Weeber Mfg. Co., April 8, 1909. Weeber marked the Pierson letter, "Ans. 4/9" but the nature of his response is unknown here.

²⁶⁷J. J. Kennedy, vice president, to C. F. Weber [sic] Mfg. Co., April 7, 1908.

²⁶⁸Kennedy to C. F. Weeber Mfg. Works, April 13, 1908.

²⁶⁹R. S. Cheek to C. F. Weber [sic] Mfg. Works, January 10, 1908.

²⁷⁰A. L. Lutz, manager, to C. F. Weeber Mfg. Works, February 12, 1908.

²⁷¹Irving O. Angier, manager, to C. F. Webber [sic] Mfg. Works, March 21, 1908.

agents in this country. We are already representing several American manufacturers and are in a position to place articles of this kind well on the market on this side, and awaiting your favour, We are, dear Sirs.²⁷²

Weeber noted on the Universal letter, "Wrote 2/18 VT 50-10% WP 40-5% SR 50% M 60%." One might interpret these figures as fifty percent discount for the valve tool plus an additional ten percent for prompt payment; forty percent for the Weeber wheel puller; fifty percent for the shock reliever; and sixty percent for the muffler.

On March 31, 1907, *The Argus* reported, "Several of the most prominent automobile manufacturers are using as a part of the equipment of their cars the new valve tool which is the latest invention of Mr. C. W. Weeber, of this city. Mr. Weeber's shock reliever and muffler, two of his earlier inventions are also having large sales."

In October 1909, the *Albany Times Union* listed the "special devices" being manufactured by the Weeber firm. Assuming that the list is comprehensive, then the four "all well nigh indispensable" items being distributed at that time included the valve tool, wheel puller, muffler and shock reliever.²⁷³ One assumes steering gear, key plug switch and stationary engine production had ended.

General Manufacturing, Unidentified Products, and Unidentified Projects

In the Weeber collection at the New York State Museum electrotypes showing a device with a patent date of October 10, 1905, do not reveal the machine's function. After inspecting images of the patents granted on that day, the author is inclined to guess that the device may be a scale or measuring instrument. In fact, on October 10, one such patent was granted to Herrmann Grassley of Albany, who said his invention "relates to a weighing device for grain to be used in stables and other places where horses and cattle are to be fed or grain weighed, especially in small quantities..." Grassley, who is listed in the 1905 and later Albany city

²⁷²F. Leanham [illegible?], managing director, to C. F. Weeber [sic] Mfg Co., January 28, 1908.

²⁷³October 4, 1909.

directories as a laborer living at 51 Spencer Street, is not known here. Interestingly, in the 1900 census Herman Gressley [sic] of Albany (born about 1847 in Germany) is identified as a stableman. Whether Christian Weeber assisted in developing the device shown in the electrotypes or even knew Grassley (or Gressley) is unknown here. Conceivably, the electrotypes could have come to him, even by accidental delivery, although the fact of its preservation in the Weeber estate would argue for his involvement.

While the M. Sommer firm likely provided most, if not all, of the ferrous castings the C. F. Weeber Manufacturing Works required in 1906 and 1907, the Cox Brass Manufacturing Company of Albany billed Weeber extensively for work during those two years. Probably some jobs were for repairs. The services of a messenger boy in a project identified as "For Mr. Battershall" could have been for the repair of Battershall's automobile. It more likely might have been for developing the Weeber shock reliever, since, as has been shown above, that was Battershall's invention. There were many Cox castings during this period, suggesting the development and manufacture of one or more Weeber products as well as repair parts.

In June 1906, there were seven castings. On July 5, there was a bill for \$3.64 to cover "6 castings from each pattern 13 lbs. @ 28" cents. On July 14, it was 24 castings from 2 patterns, twelve each; on July 23, 12 castings "from each pattern;" and on July 30, 24 castings from two patterns. In August 1906, there were 43 patterns including six of flat pieces and 25 of two patterns "in hard metal." September 27 saw a casting of a gear wheel.

The next July (1907) there were 80 castings from as many as eight patterns. On August 6, Weeber was billed for 25 times three patterns with 70 pieces delivered on August 5 and six [sic] on August 6. On August 20 another 87 pieces involving four different patterns cost \$18.11. And on August 30 still more castings numbering 25 each from three patterns were produced. The next day 27 more pieces were fabricated from four different patterns. In September, fifteen more castings were made by the Cox Company. The volume in July and August alone indicates these pieces were used in a production process but the identity of the project(s) has not been determined here. Interestingly, the Cox Brass Manufacturing Company marketed its own shock absorber a few years

later. A handbill for the CC Shock Absorber survives in the Weeber collection at the State Museum. The Cox absorber consisted of two concentric helical springs inside a "spring cage" for Ford cars and three concentric springs within the housing for heavier cars.²⁷⁴

Additional Cox Brass Manufacturing Company invoices date from 1909. On March 23, nineteen castings were produced "as per sample del." using 10.5 pounds; on March 24, 28 castings "as per sample del." consumed 21 pounds; and on March 26 uncounted castings called for 29.5 pounds of brass. The total for all 61 pounds was \$15.25.²⁷⁵

Also doing brass foundry work for Weeber was James F. White alone and later in partnership with John Kubisch. A bill from White dated April 13, 1908, is for 33.5 pounds of brass at \$.23 for a total of \$7.71. To that, Weeber has added \$16.56 and \$3.45, indicating two prior outstanding charges, for a grand total of \$27.72. On May 29, 1909, Kubisch & White were billed for fifteen pounds at \$.23 totaling \$3.45. Both bills were directed to C. F. Weeber rather than the C. F. Weeber Manufacturing Works, perhaps indicating the castings were for experimental work.

Several suppliers of metal and hardware provided materials to the C. F. Weeber Manufacturing Works in the 1900s. In spite of detailed invoices for items sold to Weeber, it is difficult to distinguish for what end most of the enumerated objects were intended or used. That is, whether these supplies were for the production of the Weeber automotive specialties, for use in developing new products or in the repair of automobiles sold or serviced. For example, a list of twenty-five different items purchased from the Croissant Hardware Company on Washington Avenue in Albany in November and December 1906 includes a wheelbarrow (\$3.25), files (\$.54 and \$.45), hammer and sledge handles (\$.18, \$.14, and \$.10 each) and screws—all objects

²⁷⁴The Ford type absorbers cost \$4.50 for a pair for the rear spring or \$8 for four. The heavy car type was \$10 for a "set for the rear." The brochure likely dates from 1915 since a license plate in a halftone is marked "Dealer NY 1915." Whether Weeber sold Cox shock absorbers is unknown here. H-1933.6.255.

²⁷⁵The earlier invoice dated March 25, duplicates the first two charges on the later invoice for a total of \$7.88. In pencil on the earlier bill, Weeber has added the \$15.25 sum from the later March 27 bill for a total due of \$23.13. Both invoices are marked stamped paid with the date of June 15, 1909, written in by "KW" for Cox Brass. The author does not understand the duplicate charges.

of a general repair shop nature. There also is a variety of toe calk steel in bar form of various dimensions and steel tire material in various widths and thicknesses,²⁷⁶ i.e., raw material for use in fabricating parts. The total charges for the Croissant bill dated January 2, 1907, is \$12.64.

"T. C. Steel" also came from Hannibal Green's Son & Company in Troy, which shipped a bundle of 3/34 x 5/16, fifty pounds at \$.0325 via National Express on March 27, 1907, and two bundles of the same material on May 25, 1907. The Albany Hardware and Iron Company similarly sold C. F. Weeber 28 pounds of the same material at \$.0275 per pound on February 5, 1907.

Cold drawn steel was shipped to the Weeber Manufacturing Works as well. On April 18, 1906, thirty-one bars of steel in various sizes, eleven bars rolled and six square in cross section, were billed at a cost of \$18.20 discounted 45% plus another 5%. Carting cost \$.25. Perhaps this lot was intended to provide the initial supply for the new Weeber facility on Central Avenue. The Sherman Street operation may have continued into November 1907, if the delivery address on invoices from Peter A. Frasse & Company in New York City were accurate. Cold drawn steel also was purchased from the Union Drawn Steel Company in New York City. One piece was shipped via American Express in early 1907, and sent to the Sherman Street address at a cost of \$5.50 less 45%. In May 1907, thirteen more pieces of cold drawn steel, both round and square, were sent to the Weeber Works; 57 pounds of material for which the charge was \$1.95 less 45%.

The two Frasse bills from November 6 and November 8, 1907, with the Sherman Street address mentioned above, are for "Poldi Diamond 5/16" (two pieces) and 7/16" (one piece), all ten inches long. The total charges were \$.70 (November 6) and \$.49 (November 8). Both invoices are marked in pencil "Send stamps", i.e., pay by sending postage stamps.²⁷⁷

The Skinner & Arnold Company in Albany billed C. F. Weeber, not the Weeber Manufacturing Works, for a steel plate "cut to size" on August

²⁷⁶The author assumes "Toe Calk Steel" and "T.C. Steel" refer to the same substance, that is, the steel alloy used in making calks for horseshoes, the projections inserted into shoes for use on slippery surfaces.

²⁷⁷A Frasse billhead from 1909 notes, "Sole American Agents for Poldi Superior Tool Steels."

23, 1907 (\$.90); "...Steel cut to order" on October 12, 1907 (\$.50) as well as for 6 pieces of steel plate (\$.80) and one additional piece (\$.40) on August 24, 1909. James McKinney & Son in Albany sold the Weeber Manufacturing Company two pieces of three-inch angle iron six-inches long for \$.40 on June 5, 1909. The Frasse concern supplied a four-foot piece of 1¼" x 14 gauge steel tubing on July 9, 1907, for \$2.76 less 65% and "cutting 10%." The delivery address is written in pencil, "255 Sherman St."

Peter A. Frasse & Company in New York also supplied the Weeber Manufacturing Works with nuts in 1906, perhaps for use in manufacturing. On July 20, Weeber was charged for five pounds of cold pressed; 3/8" five pounds of 5/16" nuts for \$2.13. On August 30, it was three pounds of blank ¼" nuts. And on October 25, Frasse sold five pounds of 5/16" blank nuts (\$1.20) plus five pounds of tapped 5/16" nuts (\$1.30). The Union Manufacturing Company of New Britain, Connecticut, shipped \$1 worth of #100 screws on November 26, 1906, less 35% plus \$.03 for postage. George A. Hebb, at 70 William Street in Newark, New Jersey, whose letterhead notes that he gave "Special attention ... to Experimental work where Springs are required," in October 1906, sold the C. F. Weeber Mfg Co. [sic] "12 Special Ex [probably experimental] Springs @ 10c each... [illegible?]. . . 19 Wire ESG 1/64 over 3/8 OSH 5/8" in Body" as well as "12 Special Ex Springs 20 Wire 6 ESG @ 10c each 1 1/32 OSH 5/8 in Body" all "FOB Newark." The total charge was \$2.40 plus \$.05 for postage. What use Weeber made of these springs has not been determined here. In July 1909, Durand & Marohn, "manufacturers of wire cloth and wire goods" in Albany, sold the Weeber firm three pounds of steel spring wire for \$.45.

Advertising

Weeber advertised his automotive specialties on a national basis. In an era dependent on print media, magazines were the vehicles of choice for promoting his products. Both trade journals and general interest publications were utilized.

Among the former class were 1/8 and 1/24 pages of *The Automobile* published in New York City. In 1906, a 1/8 page advertisement in issue eight cost \$.8.50, while 1/24 page ads in issues 15

and 22 were \$3.50 each.²⁷⁸ The charges for early 1907 were \$10 for issue 17 and \$4 each for issues 28 and 31. A letter from the Class Journal Company's treasurer, A. L. Mixer, in February 1908, attests to subsequent advertising as well as tardy payment.

We are in receipt of your favor of the 5th inst. in closing check in payment of your invoice of October 31st, and the notation up the same to cancel your advertising until further notice has been complied with.

We herewith inclose [sic] you [sic] invoice for the February 6th issue.²⁷⁹

Weeber placed quarter page advertisements (\$14.50 each) in the December 1906 and January 1907 issues and one-inch (\$4.75) ads in the March, April, July, August and September 1907 issues of the Philadelphia-based *Cycle and Automobile Trade Journal*. In December 1907, Weeber wished to place an ad in the *Trade Journal's* "Buyers' Guide."

In answer to your letter of December 17th beg leave to say that we can insert your ad in the Buyers Guide if copy reaches us this week. About 7/8 of the Journal is complete and we still have one or two forms open in which we can insert your ad.²⁸⁰

In February 1908, the Weeber Works was visited by a Mr. Busby of the *Trade Journal*. As a result, Weeber agreed to run a "page advertisement in the March number of the Journal." *Journal* secretary and treasurer C. A. Musselman wrote to ask for early submission of the copy "on account of the immense amount of work entailed in handing the March number." But he assured Weeber that "the results from the increased space will be very satisfactory to you."²⁸¹ Unfortunately, the ad appeared with inaccuracies. Musselman wrote:"

We have your letter of March 11th and note that you accept our proposition to repeat in the April number without charge the advertisement which appeared incorrectly in the

²⁷⁸An invoice stamped paid on June 6, 1906, was signed by H. C. Wormser for the Class Journal Company publishers of *The Automobile* in Manhattan's Flatiron Building.

²⁷⁹Mixer to C. F. Weeber Mfg. Works, February 6, 1908.

²⁸⁰C. A. Musselman, secretary and treasurer, to C. F. Weeber Mfg. Works, December 18, 1907. Weeber notated "Ans. 12/19" on the Musselman letter.

²⁸¹Musselman to C. T. [sic] Weeber Mfg. Works, February 7, 1908. Weeber noted on the letter, "Ans. 2/15."

March issue. This will be given our attention. We sincerely trust that you will not suffer much inconvenience as a result of the error.²⁸²

In 1908, the Weeber Manufacturing Works contracted for "13 E.O.W. insertions of one inch" beginning with the April 9 issue of *Motor Age*, published in New York City. "Complying with the request of Mr. Barnett [the *Motor Age* employee with whom Weeber had been in contact], we are having our Ad Department prepare some copy and will make a reduced cut from the illustration Mr. Barnett sends to us in soliciting the advertisement."²⁸³

Surviving invoices document advertisements in *Motor*, another New York City magazine, where Weeber ads appeared in the issues for September 1906 (one inch @ \$7), October 1906 (one inch), December 1906 (three inches @ \$21), January 1907 (three inches @ \$15.75), March 1907 (one inch @ \$5.25), April 1907 (one inch @ \$5.25), August 1907 (one inch) and September 1907 (one inch).²⁸⁴

In January 1907, Weeber contracted with *The Horseless Age* for 200 advertising inches to be used within a year. When in early 1908 he questioned a bill for \$10.50, M. Neidig, a bookkeeper for the trade journal, replied:

You only used 15 inches on this contract which was billed you at the \$1.80 rate the 200" schedule rate. Owing to the fact that you only used 15" we are now obliged (at the expiration of the contract Jan. 1st-08) to charge at the short time rate, or 15 inches at 70 cts, excess-per inch the rate for short time being \$2.50-thus the difference between \$1.80 as contracted for and charged, and \$2.50 the

²⁸²C. A. Musselman to C. F. Weeber Mfg. Works, March 13, 1908.

²⁸³H.E. Westerdale, for *Motor Age*, to C. F. Weeber Mfg. Works, March 7, 1908. Here "E.O.W." likely denotes "every other week."

²⁸⁴A pencil notation on the invoice for the December 1906 issue notes, "Cuts Placed upside down." The September and October 1906 charges were paid in February 1907; the December in March 1907; the January 1907 in April; the March and April in June; and August and September in October. The journal was published in New York City.

short time rate would be 70 cts. per inch and 15 inches at 70 cts. would be \$10.50.²⁸⁵

Other motor journals in which Weeber advertised included the Toronto-based *Canadian Motor* (April, May and June 1907 with charges of \$5.41, \$5.41 and \$5.42 respectively); *The Automobile Dealer & Repairer* of the Motor Vehicle Publishing Company in New York (one inch for one month billed in February 1907 at \$4 with subsequent charges of \$4 on March 15, \$2.50 on April 15, and \$3.50 on May 29, 1907); *The Motor World*, a New York City weekly that billed \$9 for a three-inch advertisement in the November 29, 1906 edition; and *The Motor Way*, a Chicago-based journal that billed \$16 for a quarter-page ad in the September 27, 1906 copy. In 1910, a letter soliciting advertising for *The Lever* ("A Magazine for Automobile Owners"), reached the Weeber Manufacturing Works.²⁸⁶

Buyers' guides were another venue for Weeber advertising. Weeber paid \$20 in June 1907 for an advertisement and then in September 1907 \$12.50 for a quarter page advertisement in the "Automobile Edition" of the *Buyers' Reference*, a quarterly published in New York City.²⁸⁷ As a condition of his agreement with the Gage Publishing Company, Christian Weeber was able to borrow the "yellow Lists of Buyers which we loan to advertisers." The lists were to be returned when the contract expired. A letter from Gage office manager John C. Prior dated March 13, 1908, followed up an earlier, February 25 request "to return these compilations at your convenience."²⁸⁸ Weeber marked the Prior letter "Ans. 3/18," and one assumes he either re-

²⁸⁵Neidig to C. F. Weeber Mfg. Works, March 4, 1908. Neidig had written on February 21, 1908, to ask for the \$10.50 "still due us." Weeber had replied on March 3. He answered the second Neidig letter on March 6 but his notation ("Ans. 3/6") does not reveal his response.

²⁸⁶M. M. McArdle to Advertising Manager, Weeber Mfg. Works, May 4, 1910.

²⁸⁷The invoice dated September 20, 1907, is from The Buyers' Reference Co., Inc., at 123 Liberty Street. Other editions of the *Reference* were intended for purchasing agents for steam, architectural, telephone and marine products.

²⁸⁸The letterhead notes the Gage concern was the "Successors" to the Buyers' Reference Company. The letterhead also notes that the quarterly automobile editions appeared as March, June, September and December publications.

turned the lists or agreed to a new contract for additional advertising.

In March 1908, Robert Wolfers, manager of the *The Automobile Trade Directory*, a quarterly publication of the Class Journal Company (also publisher of *The Automobile*), wrote to the Weeber Works “in connection with your advertising in The Automobile Trade Directory.” Wolfers’ firm was sending Weeber “by express today, a copy of our new Mailing List which is loaned to you in connection with your advertising....”

In compiling this new List, no expense or pains have been spared in following up every known source of information in an endeavor to make it absolutely complete, accurate and up-to-date.

In the future, monthly supplements will be issued giving all additions and changes which will keep the List in good condition.

Trusting that you will find it of value in marketing your goods, we are...²⁸⁹



Registration lists of car owners could serve as a means to locating potential customers. Two identical lists of New York auto registrants for 1914 survive in the Weeber collections at the New York State Museum. In addition, there is a solicitation letter dated April 14, 1908, from the Auto Directories Company of New York City, publishers of “Certified Copies of the Official List of Auto Owners, Chauffeurs, Dealers, Garages, Manufacturers and Jobbers,” noting that, “Sometime ago, we received an inquiry from you regarding our list of automobile owners.” With spring at hand and thousands of cars being put into service for the warm weather months, their owners needed “supplies and accessories.” Whether Weeber purchased any of the Auto Directories Company’s “absolutely correct, revised and dependable up-to-date lists” is unknown here.²⁹⁰



More general C. F. Weeber Manufacturing Works advertising venues included the *Scientific American* magazine (paid \$10.50 in 1907); the Albany *Times Union* newspaper (\$1.35 in June 1907 and

²⁸⁹Robert Wolfers to C. F. Weeber Mfg. Works, March 10, 1908.

²⁹⁰The letter is signed by J. A. Herren, secretary.

\$191.60 billed on October 30, 1919²⁹¹); the “Auto Repairman” section of New York City’s *The World* (four lines one time at sixty cents in June 1906); *The Boston Budget*, (where an advertisement for the shock relievers cost \$4 plus \$1 to make an electrotrope in March 1907); and *The Telegram*, the Albany Sunday newspaper published by the Albany Telegram Company (invoices billed \$11.25 for 30 inches on November 21, 1909; 25 inches on March 6, 1910, billed \$9.37; and 25 inches on March 13, 1910, billed \$9.37). After being billed for the total charges, \$29.99, on the first of April, June, September and October, 1910, Weeber finally marked the penultimate invoice “Pd. 12/1/10.”

Local newspapers in the late 1900s were pleased to print automotive news of a local nature. Consequently, Christian Weeber was contacted by several papers seeking items of potential interest. Perhaps the publishers also thought by seeking out the auto dealers that advertising might accompany the news stories.

Martin H. Glynn, editor and publisher of the Albany *Times Union*, wrote in February 1910:

Dear Sir:

The *Times Union* would like to run all the local automobile news. Whenever you sell anyone the cars which you handle, we will be pleased to make mention of the fact, if you will furnish us with the information. We would also be pleased to run any news stories about your garage, your cars, or your customers, if you will kindly send them in to us.

Please address all such communications to either Martin H. Glynn or James T. Glynn. If you will kindly furnish us with such news, we will be pleased to stimulate all the interest in automobiles that we can among our readers and this is sure to rebound to the credit of your business ultimately.

Won’t you please help us in this matter by mailing us such items of news as you think will help the automobile business in these parts. If you will, you will oblige us greatly.²⁹²

Accompanying the letter, or arriving about the same time, was notice from James J. Kane, *Times Union* advertising manager, alerting the recipients that the paper was going to publish a special auto number in conjunction with the Albany auto show.

²⁹¹Given its date, this is an odd surviving statement among most dating from a decade earlier.

²⁹²Glynn to “Dear Sir,” February 21, 1910.

"Good half-tone cuts of models you intend exhibiting, together with news matter of interest to prospective purchasers will be appreciated by us when sent in addition to display copy."²⁹³

The *Schenectady Gazette* also sought "any automobile news of general interest that you will advise us of with reference to purchasers of new cars, automobile gossip and any other matter that would be of general interest to automobilists."²⁹⁴ On the other hand, J. Wallace, co-publisher of *The Evening Dispatch* in Cohoes, wrote to claim "a splendid opportunity for you to secure an entirely satisfactory and profitable patronage from this city and part of the State" in the "oldest and largest paper in the city." In short, he sought advertising that would "get good results."²⁹⁵ There was no mention of items for the news columns.

As noted, in late 1906 the Weeber Works contracted for a quarter-page advertisement in the *Official Manual, Guide and Book of Reference of the Professional Chauffeurs' Club*, a publication that probably was distributed in early 1907.²⁹⁶

Weeber advertising appeared on maps distributed by the American Motor League from its New York City office. A two-inch advertisement on 5000 "official maps Albany to Utica" cost \$10 and one inch on 5,000 Albany to Lake George maps cost \$5, billed together on January 24, 1907. In early 1908, Weeber ordered "1,000 World Map blotters, showing automobile route New York to Paris" from Rand, McNally & Company in Chicago.²⁹⁷ On July 29, 1909, the Lakeside Hotel at Thompsons Lake billed C. F. Weeber \$25 for "your add [sic] in our Hotel register." Other Weeber dealings with the hotel's manager, J. M. Oaks, are recounted elsewhere in this work.²⁹⁸

²⁹³Undated printed document.

²⁹⁴A. N. Liecty, secretary and manager, to C. F. Weeber, April 21, 1908.

²⁹⁵Wallace to C. F. Weeber Manufacturing Works, April 11, 1910. The letter head notes "J. & M. Wallace, Publishers."

²⁹⁶Both the contract dated November 13, 1906, and the invoice dated January 22, 1907, survive in the Weeber collection at the New York State Museum.

²⁹⁷The Rand, McNally cover letter is dated March 12, 1908. "New York to Paris" likely relates to the New York to Paris automobile race that began in New York on February 12. The winning Thomas Flyer car (built in Buffalo) reached Paris from the east on July 30.

²⁹⁸The bill is dated July 29, 1909. Weeber marked it "sent 8/3" likely in response to Oaks request for a credit memorandum.

In addition to circulars for identified products described elsewhere, the Argus Company in Albany provided handbills to the Weeber Manufacturing Works in April 1906 (400 pieces for \$5); in September 1906 (500 four-page circulars at \$6); and in January 1907 (6,000 pieces at \$22.50). Whether these broadsides were for Weeber specialties or for the automobiles Weeber sold as agent for other manufacturers is not clear. A charge by the Argus company for printing on "furnished circulars" (\$1.75 on October 27, 1906) suggests for whatever was being promoted that Weeber was serving as a dealer whose address was added to broadsides supplied to him by another party. The Argus Company also billed Weeber for electrotypes without specifying the nature of the images.

Electrotypes also were produced by the Austin Engraving Company in Albany. In addition to the shock reliever halftone mentioned above, the Austin firm billed Weeber for two photographs "direct from objects," two halftones of "machines," two electrotypes and six hours of an "artist's & engraver's time," all at a cost of \$12.30 charged on February 23, 1906. Another halftone (\$1.50) and nine electrotypes (\$2.25) were charged by the same company on July 17.

The effectiveness of Weeber's advertising is difficult to judge. The existence of queries in letter form from locations far from Albany indicates some success in arousing interest among potential retailers of Weeber products. Among surviving incoming correspondence from 1908 is a letter from the C. & H. Motor Company, automobile agents in Willshire, Ohio, which, on March 9, 1908, sent a request for catalogues and "prices of tools." Christian Weeber noted on the incoming letter, "an [answer] 3/12 VT, [valve tool] 30%; SR, [shock reliever] 30%; M, [muffler] 50%; WP [wheel puller] 20%."

In a 1909 letter to the C. F. Weeber Mfg. Co. from William G. Hoffman, a delivery wagon manufacturer in Cleveland, Ohio, wrote, "I intend going into the manufacture of gasoline automobiles and would be pleased to have you forward me your catalogue, price list and discount." The extent of any business between Weeber and Hoffman is unknown here.²⁹⁹

²⁹⁹The letter is dated August 12, 1909. Weeber marked the sheet "write" and "8/17." Kimes and Clark, p. 706, state "Hoffman of 79 Bolivar Street" was listed as an automobile manufacturer in the Hiscox book *Horseless Vehicles, Automobiles, Motor Cycles* published in 1900. The extent of his auto-

Another request for information about several products, likely in response to an advertisement, came from the Motor Parts Company in Manhattan. Circulars were requested for the shock absorber, wheel puller, muffler and valve tool as well as “your regular net prices, or discounts to users, dealers, jobbers and manufacturers.”

Will you kindly advise us whether you conduct your own sales, or is it done through an agency? We are desirous of securing two or three additional lines, either exclusively, or in a quantity basis. We have several automobile factory customers who purchase nearly all of their equipment through us, and our company was formed on a plan which gives us the preference with eight of the largest automobile manufacturers.

Weeber noted on the Motor Parts letter, “Ans. 3/21 no price quoted 4 cir.”³⁰⁰ What further contact between the Weeber and Motor Parts companies might have taken place is unknown here.

Another major distributor of automobile parts in New York City was Charles E. Miller, whose letterhead claimed he was a “Manufacturer, Jobber, Exporter and Importer” doing business as “The Largest Automobile Supply House in America.” The Miller firm wrote to the Weeber Company on January 11, 1908, asking, in preparation for the Miller 1908 catalogue, for the “best quotation to us on you line of material.” In support, Miller noted that they operated eight stores (in New York, Philadelphia, Boston, Cleveland, Detroit and Buffalo in addition to Brooklyn and Manhattan) and published “the largest catalog of its kind in this country” with circulation of 50,000 to 60,000 copies. Miller also asked, “what price you quote to the dealers so we may know what margin of profit you allow for jobbers. We would like to know if you will make us a proposition regarding representing you in the several cities where we have branch stores.”³⁰¹

motive activity is not known. A turn-of-the-century Cleveland city directory reference to his business indicates him as the “manufacturer of fine delivery wagons.” Hoffman’s 1909 letterhead gives his address as 821 Bolivar Road and states the business was founded in 1888.

³⁰⁰R. E. Hardy, president of the Motor Parts Company, to C. F. Weeber Mfg. Works, March 18, 1908.

³⁰¹Charles E. Miller (rubber stamped signature) to C. F. Weeber Mfg. Co. [sic], January 11, 1908. Weeber noted in pencil “Ans. 1/13.” This is one of two surviving Miller letters to Weeber from this date. The second orders twelve valve tools.

Other solicitations or requests from the winter of 1908 came from the Kansas City (Missouri) Automobile Supply Company (“Manufacturers Distributers” [sic]), which also was preparing a catalog and asked for Weeber’s “electrotypes with desired reading matter at once”³⁰² From the E. G. Bernard Company in Troy, New York, “Manufacturers of Dynamos, Motors, Electrical Supplies” a request for “your latest catalogue on automobile supplies with price list and best jobber discount sheet applying to same” was met, according to pencil notations with circulars for the valve tool (50), the wheel puller (40), muffler (60) and shock reliever (50), perhaps indicating the relative popularity of the several Weeber products.³⁰³

In 1909, the Manhattan Electrical Supply Company wrote the Weeber works.

We are about to open Departments for the Sale of Automobile Supplies in all of our stores, and would ask that you kindly mail us copy of your catalogue illustrating such material as used in this line, together with your best jobbing prices.

If you have established resale prices to Consumers, Garages, and etc, would ask that you give us full data.³⁰⁴

In 1910, Weeber received a solicitation from the Guarantee Tire and Rubber Company in Indianapolis, which was preparing a 200-page catalogue for distribution “throughout the West, the Great South West and neighboring States.” It was going to distribute 50,000 copies among dealers and consumers. “We want your line to appear in our 1910 Trade Catalogue.”³⁰⁵

Also in 1910, Weeber was contacted by William W. Gibson in Albany to ask whether Weeber might wish to advertise in the annual publication of the Albany Musical Association. A full page would have cost \$10; a half page \$5 in the book, which was to be “mailed to over three thousand peo-

³⁰²G. Hillmann [illegible ?] for the Kansas City Automobile Supply Company to C. F. Weeber Mfg. Co. [sic], January 21, 1908.

³⁰³The E. G. Bernard Company to C. F. Weeber Mfg. Co., [sic], March 27, 1908.

³⁰⁴The letter dated May 22, 1909, was signed by Charles E. Merrill, purchasing agent. The Manhattan letterhead lists New York and Chicago branches with factories in Ohio and New Jersey. Weeber marked the letter “5/26 Copies” and “write.” H-2000.39.

³⁰⁵Guarantee Tire and Rubber Company sales department (unsigned) to “Mr. Manufacturer,” January 17, 1910.

ple in Albany and by most of them... kept for reference."³⁰⁶ Whether Weeber responded to either of the Guarantee or Albany Musical letters is not known here.

Trade Shows and other Selling Media

In late October 1906, *The Albany Argus* newspaper reported that, "Mr. C. F. Weeber will exhibit his inventions at the A.C.A. [Automobile Club of America] show to be held at the Grand Central Palace on Lexington Avenue and Forty-Third Street, New York City, from December 1 to 8."³⁰⁷

A few weeks later, the paper announced that Weeber and his business partners, W. J. Sutherland and Harry Sutherland, as well as other figures in the Albany motor world, "will go down to the automobile show from December 1-8, inclusive, in New York."³⁰⁸ Apparently, Weeber also exhibited at the January 1907 Seventh Annual National Automobile Show at Madison Square Garden in Manhattan.³⁰⁹ In November 1906, he "made a flying trip to New York... to complete arrangements for exhibiting his inventions at the show...."³¹⁰

In the course of its work, the C. F. Weeber Manufacturing Company was contacted by commercial agencies promoting mass produced facsimile typed letters;³¹¹ a new photo-engraving process combining the "detail of the halftone and the richness of the photogravure;"³¹² photographs in large quantities for sales and advertising purposes,³¹³

³⁰⁶William W. Gibson on Walker and Gibson Wholesale Druggists letterhead to C. F. Weeber Mfg. Works, January 25, 1910.

³⁰⁷*The Argus*, October 28, 1906.

³⁰⁸November 18, 1906. The other named showgoers were C. S. Ransom, J.R. Taylor, Roy Robinson, C.D. Hakes, A. [Archland or Archibald] J. McClure and E.H. Leahey.

³⁰⁹*The Argus*, January 13, 1907, lists Weeber among a group of thirty-one named men in the automobile business "and others" attending the exhibition.

³¹⁰*The Argus*, November 11, 1906. Of course, "flying" signifies a quick trip rather than one traveled by aircraft.

³¹¹D. A. Ahrend for the D. H. Ahrend Company (New York) to C. F. Weeber Manufacturing Works, April 26, 1910.

³¹²W. J. Roth for the R. R. Donnelley & Sons Company (Chicago) to C. F. Weeber, Jr., June 4, 1910.

³¹³J. E. Peters for Garraways Limited (New York) to C. F. Weeber Mfg. Works, February 7, 1910.

binders for photographs,³¹⁴ name plates,³¹⁵ and miscellaneous selling novelties.³¹⁶ What use Christian Weeber made of these devices, if any, has not been determined here.

As will be shown below, as an inventor, Christian Weeber remained active developing new concepts and products to the end of his life. That in the 1910 period he was viewed as busy both manufacturing items previously developed and working on new products for the automotive trade is documented by a paragraph in the *Knickerbocker Press*, "Automobile Number," for February 11, 1912, page 17.

The C. F. Weeber Manufacturing Works on Central Avenue is one of the pioneer institutions in the city and makes most everything for automobiles. Mr. Weeber is one of the leaders in his profession and has many inventions under consideration that he will shortly put upon the market.

³¹⁴Barrett Bindery Company (Chicago) to C. F. Weeber, May 16, 1910.

³¹⁵American Name Plate and Manufacturing Company (Chicago) to C. F. Weeber Mfg. Co., March 9, 1910; Zero Marx Sign Works (Chicago) to C. F. Weeber Mfg. Co., April 7, 1910.

³¹⁶William F. Durnan, secretary, for Bastian Brothers Company (Rochester), May 11, 1910.

CHAPTER 5. THE WEEBER ENTERPRISES: C. F. WEEBER MANUFACTURING WORKS; CENTRAL AUTOMOBILE COMPANY; ALBANY STORAGE BATTERY COMPANY

None of Christian Weeber's businesses were incorporated. At least there is no surviving record of incorporation for the C. F. Weeber Manufacturing Works, the Central Automobile Company³¹⁷ or the Albany Storage Battery Company.³¹⁸ In an era of relatively little business regulation or taxation, such lack of incorporation was not unusual. Information about the Albany Storage Battery Company is described in Chapter 15.

The Central Automobile Company

William G. Berg (1884-1966) told a *Knickerbocker News* reporter in 1955 that he had gone to work for "Chris Webber" as a bicycle mechanic in 1900. Later he learned machinist's skills and repaired automobiles. "When Mr. Webber joined W. J. Sutherland Sr. in an automotive agency, Mr. Berg was hired as the shop's only repairman." The implied date for Berg's employment is 1903.³¹⁹

In 1910, Willard Sutherland, Sr., himself told *The Argus* that his partnership with Christian Weeber dated from 1904, with the two "opening the

Central garage on Central Avenue, a business the newspaper called "possibly the original West End garage. In 1907 the partnership was dissolved..."³²⁰ One should bear in mind that in 1904, the Weeber Manufacturing Works still was located on Sherman Street. The building at 170-172 Central Avenue had not yet been erected. The evidence of material being delivered to the Weeber Manufacturing Works facility on Sherman Street as late as the autumn of 1907 suggests that perhaps consolidation of all the Weeber enterprises at Central Avenue might have been a factor in separating the Central Automobile Company from the Weeber Works.

Christian Weeber's active role in the Central Company is documented by a short note in *The Argus* for August 26, 1906. "Mr. C. F. Weeber, Jr. of the Central Automobile Company, accompanied by Mrs. Weeber, is contemplating making a test tour in his Maxwell car. Northern New York and the eastern states will be the territory covered." A check of city directories for 1906 and 1907 shows that the Central Company was located at 170 Central Avenue, the same address, of course, as the C. F. Weeber Manufacturing Works. Both volumes, in the "Business Directory" sections show the Central Automobile Company as a source of "supplies." Display advertisements bring the reader to

³¹⁷A Central Automobile Company was incorporated in 1903 with a New York City address (1684 Broadway). It's likely this organization is unrelated to the Central Automobile Company of Albany. See Book 92, p. 59 of the incorporation records held by the New York State Secretary of State.

³¹⁸A search by the corporations unit of the New York Secretary of State turned up no records of incorporation for Weeber's enterprises. The Baker Library at Harvard University has no corporate reports or other records of Christian Weeber's business activities, according to an email message to the author from Jean Marie Prociuous of the research staff, April 17, 2006.

³¹⁹The *Knickerbocker News* story notes that Berg was employed by "Mr. Sutherland" for 39 years, until 1942, when he went to work for the New York State Central Garage. The news story focused on Berg's retirement at age 70. The *Times Union* obituary on April 26, 1966, reported Berg's death the day before.

³²⁰March 6, 1910. The reference to "West End garage" probably indicates the location of many of the automobile agencies in the 1910s and later along Central Avenue as far west, in the pre-World War II period, as Manning Boulevard. The *Times-Union*, October 4, 1909, said the Central Automobile Company "was established 1904 and has been eminently successful." In 1909, the "members of the company" were "W. J. and H. L. Sutherland." In the 1912 city directory the Central Automobile listing has "Willard J. and Harry L. Sutherland" in parentheses, indicating they were the principals. By 1910 Berg's employment address was listed as 130 Quail Street, i.e., at the Central Company.



Figure 5.1: Photograph of Willard J. Sutherland, Sr., Christian Weeber's partner in the Central Automobile Company, printed in *The Argus*, March 6, 1910. Courtesy of New York State Library, Manuscript and Special Collections.

information only about the Weeber Manufacturing Works. One concludes operations of the two companies were entwined.

In 1907, as Sutherland reported, the Weeber and Sutherland partnership dissolved and the Central Automobile Company moved to 130 Quail Street. Additional information about Christian Weeber's involvement with the Sutherlands, especially their partnership in the sale of Maxwell and Ford cars, follows in the sections dealing with Weeber's activities as an agent for those vehicles.

The last directory listing for the Central Automobile Company was 1942, when the Sutherland's business was located at 450 Central Avenue as a dealership for Plymouth and Dodge cars and Dodge trucks. Willard J. Sutherland, Jr. and Isabelle J. Sutherland were the principals then. Isabelle continued in the automobile business in the post-World War II period.

C. F. Weeber Manufacturing Works Employees

In December 1908, Christian Weeber signed a contract with H. O. Sackett for the latter to superin-

tend the Weeber repair shop. Terms of the one-year agreement had Sackett being paid twenty percent of the shop's profits. He was to be guaranteed an advance of not more than sixteen dollars per week. Employee expenses were figured at thirty cents per hour "per man employed" to be paid by the company. Sackett would be responsible for hiring and firing. He was to be on hand every morning at seven o'clock and remain "until all is settled for the day." "Gratis repairs [,] demonstration, & experimental work to be done at cost per man & wages." Within a month Sackett was released from the contract. On January 8, 1909, Weeber wrote, "I will be in [sic] position to release you this Saturday from contract, which please return. Please tell Henry the facts of the case, that you are not capable of superintendency the shop and that I will stand by the agreements you made."³²¹

On the other hand, in the same period Weeber wrote a short letter of recommendation for E. Huber, who was leaving Weeber's employ after about a year's work. Huber likely was Ernest Huber, an Albany machinist. The letter was addressed to Peter Mc. Cartley [sic.] of Troy. In 1908, Peter McCarthy was treasurer of the Troy Waste Manufacturing Company, the Troy Knitting Company and the Commercial Union Telegraph Company and vice-president of the Troy Trust Company.³²²

An undated clipping from an unidentified Albany newspaper in 1909 says that "eight to twelve skilled workmen" were employed by the Weeber Manufacturing Works. At that time, the company served as an agency for new cars and trucks, an automotive repair shop and as a factory producing Weeber automotive specialties such as the muffler, valve tool and shock absorber.³²³

In 1907, long distance calls to Tarrytown were placed on the C. F. Weeber Manufacturing Works telephone by individuals named James Kater, Stan-

³²¹An original typed copy of the contract and a carbon copy dated December 14, 1908, are both signed by Sackett and Weeber. Both have similar but not identical pencil changes. Weeber's letter of January 8, 1909, is handwritten in pencil on C. F. Weeber Mfg. Works letterhead, signed "CFWeeber" and marked "copy."

³²²Albany and Troy city directories, 1907-1909. The only other male "E. Huber" in the Albany directories in this period was a moulder (in a foundry). A typed carbon copy of Weeber's letter is dated June 19, 1909.

³²³The clipping was sent to the State Museum by Marion Weeber on May 23, 1983. This likely is the story appearing in the *Times-Union* for October 4, 1909.

dish and Van Dusen. Spellings likely are phonetic, written by the recording agent of the telephone company on slips forwarded to Weeber for his information. Whether any of these people were Weeber employees is uncertain. No more data about them has been uncovered here.

In 1909, Weeber asks “Walter” to follow up on a Ford Motor Company-related matter. Also that year, Eskil Berg from Schenectady wrote to the Weeber Manufacturing Company [sic] on General Electric letterhead to order “2 upper spring perches for rear wheels Cat number 189 on page 18 of the 07 catalogue.” Berg wrote again to note that the spring perches received for his Ford Model N did not fit. He asked for the correct new parts “and I will return you those you sent me next time I ride down to Albany, which will be in a few days.”

About two weeks later, Berg wrote once more to ask about the replacement perches. “As I have not heard from you, I presume that the letter has been lost.” A pencil notation on the letter, not in Weeber’s hand, reads, “His Letter reads that he was coming down in a few day with them AJH [AJL or other final letter? Might this be Henry?].”³²⁴

In 1910, G. E. Ward of Ravena wrote to Weeber to say that he had ordered a spring and a box of carbide “from Tony to go down to the 5:20 West Shore train.” A few weeks before Ward wrote that “the last time I had the car there [in the Weeber shop], Henry looked it over with me and took the timer out and found it in bad shape and put on a new one.”³²⁵

A photographic view of the Weeber showroom in 1909 or early 1910 shows Christian Weeber and seven other men posing with automobiles on display. The clothing on six of the men suggests they worked on the cars directly. The seventh man, dressed in a suit, white shirt and fore-in-hand tie, probably served a clerical or sales role. Perhaps he was Henry. None of the people in the photos are identified on the mounts or in the images. (See Figure 36 for another photo of Weeber Works employees in this period.)

³²⁴The Berg letters to the C. F. Weeber Mfg. Company are dated June 4, 1909; June 16, 1909; and June 28, 1909.

³²⁵G. E. Ward to C. F. Weeber, October 19, 1910; September 29, 1910.

³²⁷Inspection of the lettering on the radiator of the car at the back of the showroom suggests a six letter word with the first letter possibly a “M.” The second Ford on the left has a non-New York registration license plate with a “1909” des-

In 1918, Alfred C. Dederick represented the Weeber Manufacturing Works at the Albany Auto Show.³²⁸ He is listed in Albany city directories as a salesman at 170 Central Avenue from 1915 through 1918, after which he was employed as a clerk by the Standard Oil Company at the Van Rensselaer Island facility.

In 1919 “Bill Glock,” “a familiar face” at previous Weeber exhibits in the annual Albany Auto Show, was going to miss the latest event. Glock, “who knows as much about a Haynes [car] as old man Haynes himself, was injured in the Weeber shops several days ago and is unable to be at the show.”³²⁹ William A. Glock first appears as a machinist in the 1911 city directory. The previous year he was a locksmith. In the 1919 directory, his place of employment is listed as 170 Central Avenue, the C. W. Weeber Manufacturing Works. The next year, without his employer being identified, he is first listed as an auto mechanic. By 1928 at the latest, Glock had left Weeber to become foreman at the Clement-Mead Motor Corporation, dealers in Hudson and Essex automobiles, at 475 Central Avenue.³³⁰

Christian Weeber and Trade Organizations

Christian Weeber belonged to the Albany Chamber of Commerce. Programs survive in the New York State Museum’s Weeber collection for the annual dinners at the Ten Eyck Hotel in 1912 and 1914. A

ignation. Marion Weeber marked the mount on the reverse “Haynes/Ford Sales & Service Shop, C. F. Weeber Mfg. Works. 1907 Albany, N.Y.” H-2000.39.82.

In the Weeber collection at the State Museum there is a second view of the same scene but without the men present. Advertisements for Model T Fords are seen on the walls in two locations in these photos. Perhaps in this period the Weeber Works also displayed a map of the United States sent by Congressman George N. Southwick, who wrote on May 8, 1909, “It will give me pleasure to send to you a map of the United States by registered mail. I always register my maps, even if it does involve an eight cents charge, because these publications seem to be particularly popular with railway mail clerks, who imagine that all public documents are legitimate spoils.” Weeber marked the Southwick letter “Write 5/14.”

³²⁸Albany *Times Union*, February 16, 1918.

³²⁹*The Argus*, February 18, 1919.

³³⁰See Albany city directories. A directory for 1927 has not been located.

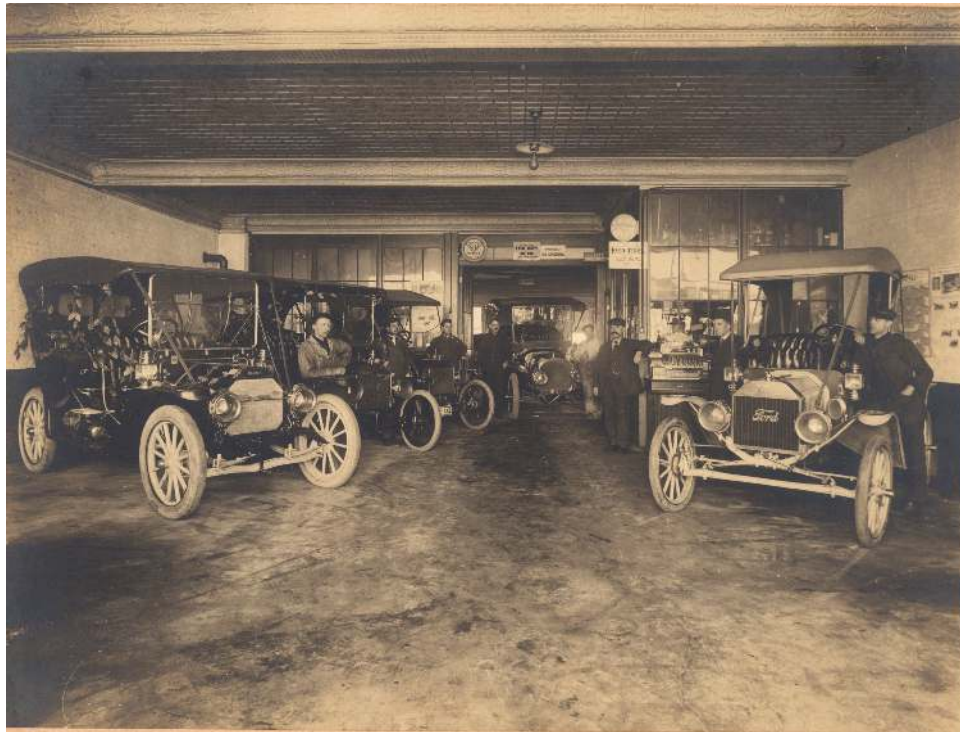

Figure 5.2: Christian Weeber and Weeber Manufacturing Works colleagues posed in the showroom at 170-172 Central Avenue with 1910 model autos. The car on the left is a Model 19 Haynes. Next to it are two Model T Fords with a third Ford on the viewer's right. The car in the center has not been identified here. Christian Weeber, of course, is the man whose left arm rests on the cash register. NYSM Collection, H-2000.39.82.³²⁷

seating chart for the latter event shows Weeber at table number two of thirty, excluding the head table. Among the guests were Governor Martin H. Glynn, former Governor John A. Dix, and Mayor Joseph W. Stevens.

At the time of his death in 1932, Christian Weeber, some twelve years since he had ceased acting as a new car agent, was still a member of the Albany Automobile Dealer's Association. He had been a member for over twenty years and once much involved. At the time of his death, however, his Weeber Manufacturing Works no longer remained on the list of active Association members.

A letter to Weeber's widow in October 1932, advised her that her husband was the owner of three shares of the Association's stock (certificate number ten) and that, "Inasmuch as membership in the Association is comprised of firms or individuals engaged in the automobile or accessory business, we shall be glad to be advised if you wish to sur-

render the stock held by Mr. Weeber, or if his business will be continued."³³¹

Real Estate

Construction of the C. F. Weeber Manufacturing Works building at 170 and 172 Central Avenue was made possible by Christian Weeber's purchase of the land from the heirs of Ada McGarvey Houck on January 12, 1906.³³² Earlier, this property had been partially occupied by the Coleman Brothers Malt House.³³³

³³¹A. M. Gahran, treasurer, to Estate of C. F. Weeber in care of Mrs. C. F. Weeber, October 28, 1932. Weeber collection at the New York State Museum.

³³²The sellers were Maria B. Van Wormer, Carrie J. Wooster, Elizabeth Mills, Alden McGarvey, Lulu McGarvey and Charles M. McGarvey. See deed recorded by the Albany County Clerk. The "Grantor Index Ledger 1895-1912" shows that Christian Weeber conveyed property on the north side of Bradford Street to St. John's German Evangelical Lutheran Church on May 23, 1906. Perhaps this was land surplus to his construction project.

³³³Sanborn insurance map, 1892.

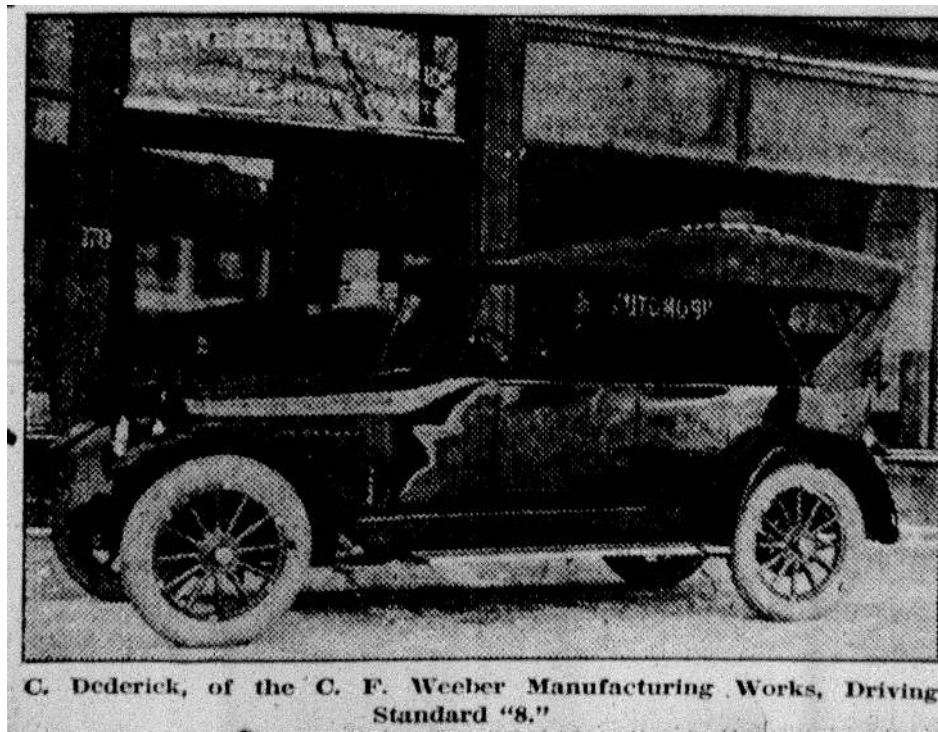

Figure 5.3: Photograph of Alfred C. Dederick behind the wheel of a Standard car in front of the C. F. Weeber Manufacturing Works showroom, printed in *The Argus*, February 18, 1917. The Standard, as well as the Allen, was a new make for Dederick and the Weeber Company in early 1917. Courtesy of New York State Library, Manuscripts and Special Collections.

In its January 31, 1906, issue *The Horseless Age* said that C. F. Weeber, "will, it is reported, erect a new factory at Central Avenue and Bradford Street, Albany, N.Y." *The Argus* took note of the planned Weeber move to Central Avenue by headlining a three-paragraph story on January 25, 1906, by noting that, "Ground [was] To Be Broken [that day] For An Automobile Factory." The move was made possible by Christian Weeber's purchase of seven lots, two on Central Avenue and five on Bradford Street. While not all the property was to be improved immediately, construction was to proceed on a stone and steel, one-story showroom to be used "as an automobile show place and factory."

Inconsistently, *The Argus* story continued:

The first floor will be for completed machines and the second floor will be a model room and a place for the working of patent specialties in which Mr. Weeber deals. To the rear of that will be the [48' x 80'] machine shop. This, when completed, will be one of the most modern and up-to-date shops in equipment in the country. Much expensive machinery, including millers and lathes which cost a great deal of money, will be installed. Au-

tomobiles and automobile specialties will be made.

The builders, Collins Brothers, expected to have the showrooms and machine shop finished by April 15 "and the remainder of the plant as soon thereafter as possible." The Sherman Street plant, "which has outgrown its original confines, will be abolished and the new and larger plant used. It is proposed in time to use the whole seven lots for the shops."

Estimates received from contractors and bills survive from the successful bidders on the Weeber job. Besides the Collins Brothers (John M. and Fred C.), the general contractors, bids were received from lumber dealers, iron works, plumbers, painters and electricians. In late January 1906, John Kurtz, Jr. & Wend quoted delivery prices for lumber. Included were 2 x 12 ft. and 2 x 10 ft. timbers (ranging from \$22 to \$24 according to length), shiplap and floor boards.

Estimates for the plumbing work included those from John J. Britt for \$225; Joseph Nicklas for

\$235;³³⁴ and Albion J. Eckert for \$175. An Eckert bill dated April 30, 1906, covers two separate "Extra Work" jobs, "changing conductor pipe" and "tinning fire walls, sides of bulk head and fitting in tubes & making same." The total cost was \$56.26. Two bills dated May 3 note the contract price of \$175 plus the extra work plus merchandise for \$4.55, making a total charge of \$235.81. Eckert noted that he had received payment of \$75 by checks on March 17; \$50 on March 31; and \$50 on April 23. That left a balance due of \$60.81. Weeber noted on two of the Eckert bills that he had paid by check on May 9. The most comprehensive of the Eckert statements is stamped paid on May 19, 1906.

A year later Eckert submitted another bill. It covered the installation of a water meter on June 2, 1906 (\$1.45); two miscellaneous charges in July 1906 and February 1907 (\$1.45 combined); and the connecting of half-inch supply lines on March 22. Supplies and seven hours of a plumber's time totaled \$13.26.³³⁵ While most of the half-inch pipe was galvanized, one length of lead pipe was used. The bill was paid on July 19, 1907.

Proposals for two 39-foot iron beams were furnished by the American Structural Steel Company at \$302 "FOB cars" and by James McKinney & Son at \$418 "delivered on premises and erected in position." Additional correspondence from the McKinney firm notes that:

...we hereby agree to furnish the IRON WORK for your new building, 170-172 Central Ave., as per plans and specifications of Architect Schade, including the 2-24" 100# steel beams, delivered on premises and erected, for EIGHT HUNDRED TWENTY-FIVE. (\$825.00) DOLLARS.

We will furnish the steel beams from stock to insure quickest possible delivery, and will furnish the 12" girder for front, and also the 12" girder for rear in one length as preferred.³³⁶

³³⁴While he was not low bidder for the initial plumbing work at 170-172 Central Avenue, Nicklas, whose shop was at 104 Quail Street, in June 1909 billed C. F. Weeber at 172 Central Avenue \$1.85 for cleaning and repairing a sink (strainer, bolts and washers for \$.35 plus 2.5 hours of plumber's time @ \$.60 per hour).

³³⁵The plumber's time was billed for \$4.20 indicating a labor cost of sixty cents per hour. The year before 1.5 hours for a plumber and helper cost \$1.05.

³³⁶J. L. Carpenter to C. F. Weeber, Jr., January 19, 1906.

A few days later, some dimensional adjustments were documented in a third McKinney letter. In addition, if the architect's plan showed a steel plate over the front girder, the steel company would provide that plate at no charges, although the McKinney Company did not remember that plate in the plans and "the architect acknowledges that is not mentioned in the specifications." Weeber was given a choice of box instead of round columns, also at no extra charge. He noted in pencil on the letter, "Decided on round posts & rosettes 1/24 AM CFW."

A February 16 proposal for the roofing on the building came from the Philip Carey Manufacturing Company. A month later, the Carey company wrote again to submit a new estimate based on dimensions, 180 x 38 ft., "including roofing on Bulk Head" recently received. The letter declared that the Carey firm was "Much pleased to learn our proposition will be accepted by you and assure you we will endeavor to give you a first-class workmanlike job in every respect."³³⁷

Electric lighting specifications came from Charles E. Rider on March 12, 1906. He proposed to outfit the first floor with three 50-candlepower "high efficiency" lamps in the showroom; three 18-candlepower incandescent lamps in the office; and fifteen 16-candlepower lamps plus two 25-foot portable lamps in the "rear or shop." There was to be one 16-candlepower lamp in the stairway and two such lamps on the second floor. Together with the necessary wire, switch, cutouts, etc., "in accordance with the rules of the Underwriters' Association of N.Y., and to be inspected by them and certificate of approval granted," the cost was to be \$64.68.

Ehmann & Beaumont agree to do your painting at your new Shop on Central Ave. as follows: Cornice, all woodwork and Iron pertaining to front on both sides two coats, all sash and frame two coats. Iron posts and partition two coats. Toilet two coats. Woodwork

³³⁷P. J. Dalie to C. S. [sic] Weeber, March 10, 1906. In the Weeber collection at the State Museum is a business card for James J. Gorman, who provided "tin, slate and corrugated iron roofing" as well as iron cornices, skylights, steel ceilings and ornamental ironwork from his shop at 14 Norton Street. Gorman moved his business to 65-67 Green Street in 1907 or 1908. See city directories.

in rear and eaves on both sides one coat for the some of one hundred dollars \$100.³³⁸

A bill from Collins Brothers dated only April 1906 carried forward a balance on contract of \$945 to which changes and charges were added. The former included substituting Indiana limestone for Oxford bluestone and raising the chimney eight inches higher than contract. The charges included masonry at 55 cents per hour and labor at 33.5 cents an hour. Bricks were \$10.50 per thousand, while Portland cement mortar was \$1.50 a barrel. The total Collins bill was \$1009.86.

A bill from Howard N. Fuller in Albany dated May 31, 1906, shows delivery of 62 barrels of Portland cement for \$119. Credits totaling \$17.77 for 237 bags of cement reduced C. F. Weeber's bill to \$101.23, a sum paid on June 2, 1906. Fuller later billed for 6.5 barrels of Portland cement delivered on February 14, 1907.

William DeyErmand [sic] & Company of Albany provided plate glass at a cost of \$180.95. Included were two 84" x 150," two 36 7/8" x 70" and one 94" x 28" polished plates as well as four sheet prism lights measuring 744" [sic] x 30."³³⁹

Elmore F. Elmore [sic], writing in May 1906 about "Garage Facilities in Troy and Albany," regretted the very limited repair shops available in the garages used largely for storing cars. He foresaw the installation of "complete machine shops" on the second floors of several large garages. And obviously writing about the C. F. Weeber Manufacturing Works plant on Central Avenue, although never identifying the location by name, he noted:

A well-known manufacturer of automobile specialties in Albany is now completing a joint salesroom and machine shop which will be the most complete in the vicinity. Already a half dozen large modern machines are installed, and when completed it will be equipped with extra heavy millers, shapers, universal grinders, lathes, drill presses, power saws, air compressor, and the like. The plant will be driven by a gas engine of the manufacturer's own design. The front portion of the building will be 40 x 100 feet

and two stories high, continued by a 60 x 100 four story building joined thereto at right angles. The forward part of the lower floor will be devoted to a showroom, while the rear will be an assembling room and machine shop. The upper floors will be reserved for the building of commercial cars and specialties. . . . The building is fairly illustrative of the prevailing methods of fire protection. It is "a slow burner," but not strictly fire proof. . .

The pits in the new garage on Central Avenue (of which there will be three) will be constructed of concrete.³⁴⁰

Surviving bills to the Weeber Manufacturing Works from Herz & Company, suppliers of electrical equipment for automobiles, suggest that the Weeber firm moved between May 21 and July 11, 1906. The earlier bill was sent to the Sherman Street address and the latter to Central Avenue.

In late 1906, the Weeber Manufacturing Works facility was to be "enlarged and the upper floor of the building, which prior to this time has [had] been used as a storage room, is to be fitted out with machinery so that all parts of an automobile, even to the smallest screw, may be made by this Albany firm."³⁴¹ In the spring of 1907, R. E. Pair said, "the newest [of six] public garage in Albany is that of the Central Automobile Company [i.e., the Weeber facility] on Central [A]venue, erected about a year ago." He described a "well lighted two story brick building of fire proof construction, with a well-equipped repair shop in connection."³⁴² *The Argus* reported the "Central Automobile Company has been making extensive improvements to its building. The front part is used as a show room and has been repainted and finished with a steel ceiling, while the rest is devoted to the machinery to which additions have been made."³⁴³

In the winter of 1908, the repair shop, still "the largest and finest equipped in this part of the state," was being enlarged. When the addition is complete, "it will triple our present plant."³⁴⁴ In the fall of 1909, the *Times Union* said the Weeber facility was a 75 x 130 ft., brick "model factory and

³³⁸"Ehmann & Beaumont" to C. F. Webber [sic], April 4, 1906.

³³⁹In the Weeber collection at the New York State Museum is an undated handbill from the Hires Turner Glass Company of Philadelphia offering plate and other glass shipped on trains leaving the Hires factory daily at "3.00 P.M. for all points between the St. Lawrence River and the Gulf of Mexico."

³⁴⁰*The Horseless Age*, vol. 17, no. 22, May 30, 1906.

³⁴¹*The Argus*. November 18, 1906.

³⁴²"Recent Garages and Garage Methods—III," *The Horseless Age*, vol. 19, no. 20, May 15, 1907.

³⁴³March 31, 1907.

³⁴⁴Advertisement in *The Argus*, various issues in February and March 1908.

garage building" benefiting by being "thoroughly fireproof".³⁴⁵

The Sanborn insurance map of 1908-1909 shows the building occupied by "C. F. Weeber, M'f'r [Manufacturer] of Autos, Motor & Parts" with two stories ("Garage 1st Stock R'm 2nd") adjacent to Central Avenue and one story to the south. A gas engine provided power. Stoves supplied heat³⁴⁶ and electric lights provided illumination. There was no fire apparatus on the premises.³⁴⁷

Equipment for the Weeber shops apparently came, at least in part, from the Fairbanks Company on Broadway in Albany. Bills from April 1906 and into 1907 record Weeber purchases of pipe, line shafting, belt lacing and belt hooks. The piping suggests the possibility of a compressed air system, useful in an automobile repair shop. The purchases of air cocks, valves and a vacuum gauge support that idea. (Compressor advertising material preserved by Christian Weeber is described below.) The surviving Fairbanks bills document purchases from April 10, 1906.



In 1907, E. F. Houghton & Company of Philadelphia shipped 25, 27, 30, 29, 36 and 28¼-foot lengths of 1C" Vim Friction Leather to the Weeber Manufacturing Works. The cost was \$.42 per foot discounted 40%.³⁴⁸ The author assumes this material was used to operate belt-driven machinery, since belting in automobiles usually was round or, if flat, narrower than 1¾." Also supplying 25-foot lengths of 1¾" leather belting was the Albany Hardware and Iron Company, which, in October 1906, billed at \$.14 per foot for one length and \$.35 (discounted 65%) for another. Both bills, a total of \$6.56, were paid in early December.

³⁴⁵October 4, 1909.

³⁴⁶A 1909 or 1910 photograph of the Weeber showroom reveals a stovepipe curving to a chimney on the east wall near the glass partition for the shop area. Whatever stove was located beneath the pipe is hidden from view by automobiles.

³⁴⁷The building to the west, later occupied by Emil Weeber's bicycle shop, housed a harness shop in 1908. The *Times Union* for October 4, 1909, confirms the continuing use of the second floor for warehousing: "The second floor of the building is used for storage purposes."

³⁴⁸The bills were prepared in April, June, July, August, September and October 1907. All were paid from one to two months after the billing date, none to complying with "30 days net."

Still another supplier of leather belting was the Ulmer Leather Company of Norwich, Connecticut. In September 1908, Ulmer shipped 124 feet of 1¾" "Alpha" single-belting at \$.42 per foot discounted "50-10%" [10% off for 50 feet] as well as 50 feet of ¾" solid belting. Weeber's order was dated September 1. Shipping followed on September 9. The bill was prepared on September 19 and paid on October 5, 1908. In the fall of 1907, J. L. Rhoads & Sons of Philadelphia, Pennsylvania, sent the Weeber firm "a sample of our Tannate Rounded Belting to test." In late November, Rhoads wrote to ask "how it serves you." Weeber "Ans. 11/27."³⁴⁹ In May 1909, E. F. Houghton & Company wrote to "return you order #193 herewith, and regret to state that we do not sell this belting."³⁵⁰

Belt dressing came from the Stephenson Manufacturing Company of Albany. In June 1906, three pounds of Stephenson Bar Belt Dressing for leather belts cost \$1.20.

A letter from Patterson, Gottfried & Hunter, Limited on Centre Street in New York in April 1908, noted, "We have just been informed that you have plans for improvements and additions to be erected to your plant. It occurs to us that you will soon be in the market for Power Transmission material." In return for a copy of Weeber's plans, Patterson was prepared to "Have a representative call on you and figure on your requirements, if you desire."³⁵¹ The Graton & Knight Manufacturing Company of Worcester, Massachusetts, also learned of the planned addition.

When we wrote to you on Mar. 7th [1908], we had in mind a recent report informing us that you would build a large addition to your plant. Yours of the 9th would lead us to infer that you are not as yet ready to consider the matter of belting for the equipping of this addition. When you do get ready, please communicate with us, and we will promptly name prices. . . . If any of your belts are run in exposed places, that is, in places where they encounter dampness, or where they come in contact with steam, gas and acid fumes, you

³⁴⁹Unsigned letter to C. F. Weeber Mfg. Co., November 25, 1907.

³⁵⁰H. F. Rappold [illegible?], department superintendent, to C. F. Weeber Mfg. Works, May 12, 1909.

³⁵¹Robert A. Adams for Patterson, Gottfried & Hunter, Limited, to C. F. Weeber Mfg. Co., April 13, 1908.

will find it to your advantage to try out some of our Neptune Steam-proof leather belts.³⁵²

In 1906 and 1907, the Weeber Manufacturing Works purchased sprockets and chain from the Baldwin Chain & Manufacturing Company of Worcester, Massachusetts. Specifically, in August 1906 Weeber bought a 6.5-foot length of chain; in September 1906 ten-tooth and twelve-tooth sprockets for use with roller chain; and in May 1907 a fifteen-tooth sprocket. The charge for two of the sprockets was by the tooth—\$.14 each. All the 1906 bills were paid together in October of that year.³⁵³ One assumes the intended use of the material was to operate machinery in the shop rather than to repair automobiles.

Christian Weeber may have considered installing an elevator or hoist in his plant as his planned the enlargement. At a minimum, he retained, among the papers in the Weeber collection at the New York State Museum, two advertising letters dated February 15, 1908, and April 10, 1908, and two identical handbills for the Brown Hoist, made by the Brown Clutch Company in Sandusky, Ohio. There also is an April 28, 1910, sales letter and handbill for Otis hand power elevators, the products of the Otis Elevator Company of New York.

A letter touting General Electric air compressors is dated January 15, 1908. An attached handbill shows heavy-duty compressors suitable for “foundry cupolas, gas furnaces, exhausters, etc.” Brochures for air compressors from the F. W. Spacke Machine Company of Indianapolis include one dated July 1, 1907, depicting compressors for

³⁵²J. P. Dorward for the Graton & Knight Manufacturing Company to C. F. Weeber Mfg. Works, March 11, 1908. Dorward’s letter actually was the third on the subject of belting for a new facility. In the second, on March 7, 1908, he suggested the first “must have been mislaid.” In that first (February 17, 1908) letter, he had asked “when you expect to be ready to take up the matter of belting.” In the second he asked for an answer to that question without any obligation on Weeber’s part. “It will mean simply that we will not bother you further with our solicitations until such time as you are ready to buy belting.” Weeber marked this second letter, “Ans. 3/9.”

³⁵³Weeber has written on the bill for the “1 x ½ det rol chain” at \$.75 per foot, “The above was a block chain is price correct.” And on the bill for the ten-tooth sprocket (\$1.40 plus \$.13 postage) he wrote, “We note here that you charge us more for 10 tooth than on enclosed bill for 12T. [P]lease send credit for amount of error.” In fact, the charge for the twelve-tooth sprocket billed on September 24, 1906, was \$1 plus \$.19 for postage.

“Automobile Garage Service” and one dated January 1, 1908. The Spacke compressors were either belt or electric motor driven. An undated, mass-produced advertising letter from the American Steam Pump Company of Battle Creek, Michigan, accompanied a card describing the two-stage belt-driven air compressor “for garage service.”³⁵⁴ Whether the Weeber Works acquired a General Electric, Spacke or American compressor or several such devices is not known here. It is difficult to imagine an auto repair shop without at least one such device in the 1910 period.

Weeber purchased a six-foot oak showcase with plate glass top for \$42 in November 1907 from the Manhattan Show Case Company along with a twelve-foot “Nickel Rod Guard.” The Mosler Safe Company of New York City sent Weeber receipts in September and December 1906 and in March 1907, documenting payment on account of \$40 for a safe purchase. In April and May 1908, W. C. Sellkamp of the Schenectady Book Binder and Printing Company wrote C. F. Weeber in handsome cursive penmanship to offer loose leaf ledgers and order books. “Let us equip you—You will never regret it.”³⁵⁵ Sellkamp subsequently paid Christian Weeber a visit and wrote again about duplicate order books that he would sell at \$17 for one-hundred books, “a good low price delivered.”³⁵⁶ Another source of office supplies was the Russell firm on State Street in Albany. An undated broadcast letter offers a \$5 coupon book worth \$6 toward the purchase of typewriter ribbons and carbon paper. In 1910, Weeber communicated with the W. H. Bundy Recording Company about employee time clocks.³⁵⁷ Whether he purchased such a device is unknown here.

In 1975, Marion Weeber described the building at 170-172 Central Avenue.

Originally in 1905-1907 to about 1922-23... the main floor facing Central Avenue, was the

³⁵⁴While the text of the letter mentions the card, the latter no longer accompanies the former.

³⁵⁵April 29, 1908.

³⁵⁶May 2, 1908.

³⁵⁷Heman [sic] D. Traver, Bundy secretary, to C. F. Weeber Mfg. Co., April 29, 1910. Traver asked, “if you are now agreeable to a personal interview with reference to the question of Employees’ Time Clocks.” Weeber marked the Traver letter “Ans. 5/2 Copy.”

Table 5.1: Fairbanks Sales to C. F. Weeber Manufacturing Works, 1906-1909; Invoices Surviving in the Collections of the New York State Museum

Date ^a	Quantity	Item	Cost
April 10, 1906	20 ft.	1 ¹ / ₁₆ " shafting, 152 lbs.	\$.05 lb. less 40%
April 23, 1906	1	1 ¹ / ₁₆ " Nicholson shafting coupling	\$6.25 less 65%
May 1, 1906	12.5 ft.	Fairbanks brand 16 oz. belt	\$.41 ft. less 55%
	100 ft.	5/16" cut lacing	\$1.25 less 45%
May 2, 1906	77 ⁵ / ₁₂ ft.	1" pipe	\$.165 ft. less 74%
	12	1" elbows	\$.105 ea. less 66 2/3%
May 12, 1906	3	1 ¹ / ₄ " elbows (\$.11 lb)	\$.77 less 35%
	3	1 ¹ / ₂ " elbows	(with previous)
	3	1" unions	\$.33 ea. less 66 2/3%
	3	1 ¹ / ₂ " unions	\$.58 ea. less 66 2/3%
May 15, 1906	6	1" elbows, 3.5 lbs.	\$.13 lb. less 35%
	3	#0 air cocks	\$.40 ea.
	3	#1 air cocks	\$.40 ea.
May 29, 1906	1	1" all iron cock	\$1.30 less 70%
	6	1" elbows. 3 lbs.	\$.13 lb. less 35% (\$.25 total for six)
June 26, 1906	6	1/2" 45 degree elbows	\$.07 ea. less 70%
	6	1/2" close galvanized nipples	\$.06 ea. less 70%
	3	1/2" elbows	\$.06 ea. less 70%
September 1, 1906	1	lb. Dixons Special Graphite	\$.20
September 11, 1906	10 ft.	2" Fairbanks 16 oz. belting	\$.41 ft. less 55%
	1	20' bar 1 1/4" shaft, 83 lbs.	\$.10 lb. less 45%
December 19, 1906	100 ft.	5/16" cut lacing	\$.015 ft. less 45%
	1	24 x 5 x 1 1 ¹ / ₁₆ 6" steel pulley	\$10 less 60%
January 4, 1907	1	2 1/2 x 5" nipple	\$.59 less 70%
March 2, 1907	3	1" malleable tees (2.25 lb)	\$.13 lb. less 30%
	6	3/4 plugs	\$.03 ea.
	12	1/8 plugs	\$.02 ea.
	12	1/4 x 1/8 bushings	\$.04 ea. (previous three items subject to various discounts decreasing \$.66 gross charge to \$.21)
	6	1 1/4 C. [close] nipples	\$.13 ea. less 70%-5% (\$.22 total charge)
	1	vacuum gauge	\$2.00
April 18, 1907	2	3/8" air cocks	\$.50 ea. (less 50%-10% = \$.45 total charge)
	6	3/8" plugs	\$.02 ea.
	6	1/4" plugs	\$.02 ea.
	6	1/8" plugs	\$.02 ea. (total with 65%-10% discounts for above three items was \$.11)
May 4, 1907	18' (17?)	1 1/2" shafting, 108 lb	\$.05 lb. less 40%
	18'	1 1/16" shafting, 135 lb	\$.05 lb. less 40%
	20'	1 1/4" shafting, 83 lb.	\$.055 lb. less 40%
May 7, 1907	6	1/8" air cocks	\$.4 ea. less 50%-10%
July 3, 1907	3	1' common unions	\$.33 ea. less 60%
	2	1 1/4" common unions	\$.46 ea. less 60%
	6	1" plugs	\$.04 ea. less 65%
	6	1/4 x 1/8" red bushings	\$.04 ea. less 60%
	12	1/8" close nipples	\$.04 ea. less 70%

^aMost invoices are stamped paid with a date approximately two weeks to two months after the billing date. The April 23, 1906, invoice notes the order came by telephone.

Table 5.1: Fairbanks Sales to C. F. Weeber Manufacturing Works, 1906-1909... *continued from previous page*

Date	Quantity	Item	Cost
	6	1" close nipples	\$.08 ea. less 70%
August 5, 1907	60 ft.	5/8" shafting, 63 lb.	\$.06 lb. less 40%
August 7, 1907	3	#0 air cocks	\$.40 ea. less 50%
	3	#1 air cocks	\$.45 ea. less 50%
August 23, 1907	10 ft.	4" 4-ply Gandy belting	\$.40 ft. less 50%-10%
August 29, 1907	1	lb. Dixons flake graphite	\$.20
August 30, 1907	10 ft.	4" 4-ply Gandy belting	\$.40 ft. less 50%-10%
October 15, 1907	1	200 lb. Chattillon Weigh Masters Beam	\$2.00
October 17, 1907	3	1/8" rough brass couplings	\$.10 ea. less 60%
	6	1/4 x 1/8" bushings	\$.04 ea. less 65%
	6	1/8" air cocks	\$.40 ea. less 55%
	3	1/8" air cocks #5	\$.55 ea. less 55%
November 1, 1907	3	1 1/2" C. [close] nipples	\$.13 ea. less 70%
November 21, 1907	4	3/8" #14 air valves	\$1.05 ea. less 50%-10%
June 16, 1909	100 ft.	1/4" R. H. lacing	\$1.25 less 30%
	100 ft.	3/8" R. H. lacing	\$1.75 less 30%
August 12, 1909	1	1/8" com. angle valve	\$.72 less 60%
	2	2 1/2 x 2" bushing	\$.21 ea. less 65%
	2	1 1/2' 4" pipe	\$1.08 ft. less 68%

Auto Showroom, and the rear of the building on the ground floor was the auto Repair & Machine Shop, which housed the Lathe [H-1975.155.1], big punch presses and other machinery and welding equipment. The ground floor ran about 100 ft. beyond the two story front building and had an open yard for car repair which ran through to Bradford Street.³⁵⁸

In the 1910s, Christian Weeber purchased the row house at 168 Central Avenue. By February 1917, the Weeber Manufacturing Works advertised they were located at "168-170-172 Central Avenue."³⁶²

Among the objects received from the buildings at 168, 170 and 172 Central Avenue by the New York State Museum after Christian Weeber's death were a number of catalogues for machinery, tools and supplies needed in a business, such as the C. F. Weeber Manufacturing Works. Many of these catalogues date from the early to mid-1900s, the period in which Christian Weeber planned and built his new facility. While it is not possible to ascribe particular purchases to items offered in these catalogues (perhaps with one exception), these booklets suggest the items Weeber considered for purchase and the possible suppliers of the materials.

The exception to the preceding statement is, perhaps, a LeBlond lathe used by Weeber, a device that is part of the New York State Museum's collection. Discussion of the use of the lathe and the acquisition by the museum follows later in this book. The 1902 catalogue, actually two identical items, depicts a twelve-inch lathe, similar to that used by Christian Weeber and preserved by the State Museum. The catalogue describes the LeBlond (and Weeber) 12-inch engine lathe as having a range of threads from five to forty per inch. Back gearing is 8 to 1. There are four drive cones for a two-inch belt. In addition, there are 23 geared feed changes from .007 to .057 inches.

The five-foot bed takes 2'6" between centers. New weight was 1,100 pounds. "The double friction countershaft has 10 in. pulleys for [a] 3 in. belt and should run 150 and 200 revolutions per

minute, giving a range of spindle speeds of 8 to 450."³⁶³

Equipment Catalogues in the Weeber Collection at the New York State Museum

Among the handbills and catalogues in the Weeber collection are those from the firms listed Table 5.2 on page 88. In the Gay & Ward catalogue of gear and milling machine cutters, Christian Weeber has written "25%," one surmises the discount he expected to receive. Those items in the following list marked "c. 1905" are not otherwise dated or datable. It should be understood that the dating for those pieces is approximate at best.

Utilities

At the time of construction of the new facility on Central Avenue, power for the Weeber repair and manufacturing machinery came from a gas-powered internal combustion engine, a product of the C. F. Weeber Manufacturing Works itself. A bill for gas use on Sherman Street between December 1, 1905 and March 1, 1906, shows that both illuminating gas (3,400 cubic feet) and fuel gas (47,400 cubic feet) were used. Between March 1, 1906 and June 4, 1906, the consumption was 400 cubic feet of illuminating gas (for \$.52); between March 1 and April 21 (likely the moving date to Central Avenue), 21,000 cubic feet of fuel gas (at a cost of \$21.62) was consumed at the Sherman Avenue plant.

From September 1 to December 1, 1906, only illuminating gas was consumed at the new Central Avenue facility. The cost for 43,000 feet was \$55.90. Only illuminating gas also was purchased from December 1, 1906 to March 1, 1907; 49,700 feet at \$1.00 per thousand cubic feet. Since no fuel gas was billed for these months, it appears that illuminating gas was used to power the internal combustion engine that Weeber built and run his machinery. Perhaps in error Weeber was being sent the illuminating fuel that he did not require. The bill for March 1 to April 26, 1907, shows entries for

³⁵⁸Marion Weeber Welsh to Geoffrey N. Stein, December 10, 1975.

³⁶¹Words visible on the wagon body include "tapestries," "rugs," "upholsteries," "carpets," "without," "injury," "estimates" and "furnished."

³⁶²*The Argus*, February 23, 1917.

³⁶³R. K. LeBlond Machine Tool Company, *Illustrated Catalogue of Machine Tools* (Cincinnati, 1902), p. 13.



Figure 5.4: Photographic Print, c. 1909. “C. F. Weeber Mfg. Works. Salesroom & Service Repair Shop Haynes & Ford Cars—Agency 1909.” Apparently taken during the winter, this heavily retouched print was used as an image for Weeber advertising. Postcards with this picture on them do not show the building on the left with the piles of snow in front. Retouching eliminated the snow in front. Retouching also eliminated the snow in front of the two (Christian’s Manufacturing Works and Emil’s bicycle enterprise) Weeber businesses and strengthened the appearance of the two cars as well as the lettering on the Manufacturing Works windows. The upper story windows also have the retoucher’s ink on them to eliminate glare. NYSM Collection, H-2000.39.80.



Figure 5.5: Postcard, c. 1909. Interior view of the machine shop at the rear of 170-172 Central Avenue. Marion Weeber dated this image as 1907 but the Model T Ford at the center of the picture would suggest 1909 or 1910. Christian Weeber stands to the right of that car, wearing a leather coat and cap. Marion Weeber also identified a “salesman in car, waring [sic] cardigan sweater.” She added that there was an “open testing yard back of machine shop ran thru to Bradford Street.” And that the machine shop “moved upstairs—about 1919 after renting store to Kelly Springfield Tire Co.” On another print of this image, she wrote, “Repair Service Garage and Machine Shop. . . 1907” [sic]. The wagon or truck body behind Christian Weeber is marked with words indicating its owner was a tapestry, rug and upholstery cleaner.³⁶¹ In addition to Weeber, several of the men here also appear in the photo of the showroom in Figure 5.2.

Table 5.2: Companies listed in handbills and catalogues in the Weeber collection.

Name	Place	Goods	Date
Niagara Machine & Tool Wks.	Buffalo, N.Y.	Sheet metal equip.	1926
Morgan Spring Company	Worcester, Mass.	Wire and springs	c. 1905
Emmert Mfg. Co.	Waynesboro, Pa.	Vises	1906
Diamond Saw & Stamping Wks.	Buffalo, N.Y.	Hack saws	c. 1905
B. F. Barnes Co.	Rockford, Ill.	Upright drills	c. 1905
Whitney Mfg. Co.	Hartford, Ct.	Woodruff keys, cutters	1905
Keystone Screw Co.	Yardley, Pa.	Machine screws, etc.	1921
Oliver Mfg. Co.	Chicago, Ill.	Jacks (wagon, lifting)	1904
Patterson, Gottfried & Hunter, Ltd.	New York, N.Y.	Metals	c. 1905
Gem Manufacturing Co.	Pittsburgh, Pa.	Oilers, etc.	c. 1915
J. G. Blount Co.	Everett, Mass.	Grinding equipt., etc.	c. 1905
Gardner Wire Co.	Chicago, Ill.	Springs, hardware	1925
Gardner Wire Co.	Chicago, Ill.	Rubber, wire, etc.	1921
Baird Machine Co.	Bridgeport, Ct.	Ball burnishing mach.	1918
Boston Gear Works	Boston, Mass.	Sprockets, chains, etc.	1908
Henry Disston & Sons	Philadelphia, Pa.	Files and rasps	1905
Athol Machine Co.	Athol, Mass.	Vises, etc.	c.1905
Pannier Bros. Stamp Co.	Pittsburgh, Pa.	Markers	c. 1925
Chas. D. Durkee & Co., Inc.	New York, N.Y.	Marine hardware	c. 1901
Hendey Machine Co.	Torrington, Ct.	Shapers	1900
Medart Patent Pulley Co.	St. Louis, Mo.	Pulleys et al.	1907
Townsend Furnace... Co.	Albany, N.Y.	Gear patterns etc.	1905
Lunkenheimer Co.	Cincinnati, Ohio	Valves et al.	1902
Stow Mfg. Co.	Binghamton, N.Y.	Flexible shafts	1901
Ball Bearing Co.	Boston, Mass.	Bearings	c.1900
L. Best Co.	New York, N.Y.	Wheel dresser	c. 1910
Gay & Ward	Athol, Mass.	Gear cutters	1901
F. A. Errington	New York, N.Y.	Lathe accessories	c.1910
Modern Tool Co.	Erie, Pa.	Tapping attach.	c.1905
Chase Brass & Copper Co., Inc.	Waterbury, Ct.	Metals	1929
Winkley Co.	Hartford, Ct.	Oiling devices	c. 1905
Francis L. Freas Glass Wks.	Conshohocken, Pa.	Hydrometers, etc.	1918
Oneida National Chuck Co.	Oneida, N.Y.	Chucks	1909
Westcott Chuck Co.	Oneida, N.Y.	Chucks	1906
R. K. Leblond Machine Tool Co.	Cincinnati, Ohio	Milling machines	c. 1903
Billings & Spencer Co.	Hartford, Ct.	Tool holders	c. 1905
Woodward Co.	Albany, N.Y.	Steel	c. 1920
Hobbs Mfg. Co.	Worcester, Mass.	Washers	c. 1905
Armstrong Bros. Tool Co.	Chicago, Ill.	Tool holders	c. 1900
Mass. Steel Casting Co.	W. Everett, Mass.	Steel castings	c. 1905
Graham Mfg. Co.	Providence, R.I.	Jig vise	1902
Phillips-Laffitte Co.	Philadelphia, Pa.	Welding plates	1906
Whitney Mfg. Co.	Hartford, Ct.	Milling machines	1906
Canton Fillet Co.	Canton, Ohio	Foundry supplies	c. 1905
Pratt & Whitney Co.	Hartford, Ct.	Machinery tools	c. 1905

illuminating gas erased with consumption of fuel gas (30,600 feet) in place. The difference in cost was \$.20 per thousand feet, i.e., \$1.20 versus \$1.00. For the next billing period, April 26 to September 1, 1907, the price for the two different gases was the same; \$1.00 per thousand feet. Weeber was billed for 73,400 feet of illuminating gas, apparently his preferred fuel.

Whether any gas was used in the room heating stoves in the following years at 170-172 Central Avenue needs to be determined. Consumption of 3,600 cubic feet of fuel gas (contrasted with illuminating gas) during the warm weather period between May 21 and June 21, 1909, suggests that the gas sold at a cost of \$3.60 to Weeber, as fuel was used for powering equipment. Other surviving Municipal Gas Company bills for the Central Avenue facility include those for \$4 (June 21 to July 21, 1909); and \$6.80 (September 18 through October 20, 1909); all at \$1.00 per thousand cubic feet. Perhaps the higher cost in the last period indicates some gas being used for heat.



In the later 1900s, electricity was provided by the Albany Electric Illuminating Company. The bill for April 1 to July 1, 1906, documents use at 170 Central Avenue of 20,700 watts at eight cents per thousand for a total cost of \$1.65. A bill for August 1, 1906 to September 1, 1906, indicates consumption of 13,300 watts at 8 cents per thousand for a charge of \$1.06. A second bill for the same period shows use of 17,400 watts at a cost of \$1.39. While this double billing suggests two meters and two accounts, additional surviving bills for 1906 and 1907 make no mention of multiple accounts. By 1909, as seen below, there clearly were two billing accounts.

In October 1906, 44,900 watts were used (\$3.59); in November 1906, 40,800 (\$3.26); in December 1906, 61,500 watts (\$4.92); in February 1907, 37,000 (\$5.71); in March 1906, 29,000 watts (\$2.32); and in May 1907, 13,000 watts (\$1.04). On November 13, 1906 and May 3, 1907, C. F. Weeber was charged for 24 lamps each date for a combined cost (two billings) of \$6.96.

Electricity use for March 25, 1909 to April 25, 1909, was 52,000 watts (\$5.20) on one bill and 197,000 watts (\$7.88) on another. Both were sent to C. F. Weeber at 170 Central Avenue. For the next month, the charges were \$7.20 (72,000 watts at

10 cents per thousand) on Account 48-2 and \$6.92 (173,000 watts at 4 cents per thousand) on account 48-1. Also, in May Weeber was billed \$3.48 for 24 sixteen candlepower lamps. From June 25 to July 25, 1909, account 48-2 was billed \$7.10 for 71,000 watts registered on a meter.

While initial power for machinery in the Central Avenue facility was provided by a Weeber gas engine and belt transmission, apparently some electric motors soon were in use. In 1907, the General Electric Company of Schenectady repaired a field coil for a one horsepower "IC 500 V Motor—Spec. #33" for a charge of \$9.65 plus \$.65 for shipping.³⁶⁴ Also in 1907, the E. G. Bernard Company of Troy rewound two field coils for the Weeber Works at charges of \$5.60 and \$6.30.³⁶⁵

Communications

In the 1900s, Christian Weeber and the C. F. Weeber Manufacturing Works relied upon three media for business communications: mail, telegraphy and telephony. Imprinted statement forms, letterhead stationery and envelopes in the 1906 and 1907 period were provided by *The Argus* company in Albany. Typical of bills during the two-year period were Argus charges for 2,000 envelopes (\$7), 1,000 letterheads (\$4.50) and 500 statements (\$2.50).

The oldest surviving telephone bill from the Hudson River Telephone Company dates from March 1, 1906. It is addressed to C. F. Weeber, Jr. at 55 Sherman Street, where the telephone number was W257R. The monthly rental charge was \$4 with toll calls incurred in February adding another \$40.³⁶⁶ Documenting the Weeber firm's move, toll slips from June 1906 record calls from West 460, the number for the C. F. Weeber Manufacturing Works on Central Avenue.

The Hudson River Telephone Company bills counted local calls within the monthly billing periods. Local calls at the Weeber Manufactur-

³⁶⁴Weeber's customer order number was 4/11/07. The billing date was May 16, 1907.

³⁶⁵The bill dates were September 14 and 30, 1907. Payment followed on September 16 and 30, respectively.

³⁶⁶For the same period and for several months following, to Christian Weeber's telephone bills are pinned those for E. [Emil] O. Weeber, number W358L, for his residence at 272 Western Avenue. The monthly rent for that telephone was \$2. The Christian Weeber family, it should be recalled, resided in an apartment in the Emil Weeber house.

ing Works totaled 137 in September 1906; 112 in November 1906; 143 in March 1907; 132 in April 1907; 133 in May 1907; 203 in July 1907; 231 in August 1907; and 160 in September 1907. Toll calls were fewer. The longest surviving list, that for late June and most of July 1907, shows eleven regional toll calls, i.e., Schenectady, Troy, Glen, Cobleskill, Cohoes, etc., and no American Telephone and Telegraph long distance calls in that month.³⁶⁷

In the 1900s, two telephone companies operated in Albany and many commercial operations maintained service in both systems. In addition to the Hudson River Telephone Company bills, the Weeber collection at the New York State Museum includes a partial Albany Home Telephone Company bill to C. F. W[e]eber dated October 1, 1907. The total for service between October 1, 1907 and January 1, 1908 was \$9 with a 10% discount if paid on or before October 10, 1907. The bill is stamped paid on October 12, 1907. Another Albany Home Telephone Company bill for Exchange Number 460 (Weeber had the same number for both systems.) totaled \$1.94 for service in September 1909.

In January 1908, W. J. Cleveland, superintendent of construction for the Hudson River Telephone Company, wrote to Christian Weeber at 170 Central Avenue, "Beg to acknowledge receipt of your favor of the 20th inst., in relation to your telephone trouble, and wish to advise that it will have our immediate attention."³⁶⁸ Weeber marked the letter, "Re. 1/22 C."

In March 1908, P. G. Ten Eyck wrote to "Mr. W[e]eber" from Atlantic City, New Jersey, to say he had just arrived but "hasten to write and ask if you have brought my auto into the city as yet." If so, Ten Eyck wished to know "what conclusion have you arrived at as regards repairs." He was curious to know what Weeber thought "necessary and the approximate cost."³⁶⁹ Weeber marked the

³⁶⁷Examples of long distance calls in other billing months during 1906 and 1907 include conversations with personnel at the Maxwell-Briscoe Motor Company Tarrytown, the H.H. Franklin Manufacturing Company in Syracuse and the Whitney Manufacturing Company in Hartford, Connecticut.

³⁶⁸The Cleveland letter is dated January 21, 1908.

³⁶⁹Ten Eyck, on Galen Hall stationery, March 5, 1908. Peter G. Ten Eyck, according to the 1907 Albany city directory, was manager of the Federal Railway Signal facility on the Troy Road "beyond city line" in what later became Menands. He lived at 142 Washington Avenue. Perhaps Ten Eyck's car had become inoperable at the Federal factory.

letter "Called." One assumes he telephoned Ten Eyck.

By June 1, 1909, the Weeber Manufacturing Works was being billed by the Central New York Telephone and Telegraph Company rather than the Hudson River entity. For May 1909, there were 301 calls with separate billing for ten toll calls. For July, there were 241 calls with 21 toll calls. One toll number that has been identified is 1634 in Troy, the telephone for Scott D. Nichols, the Ford dealer there. In August 1909, 241 calls with thirteen toll calls added \$3.08 to the monthly exchange service charge of \$4.17.

A bill from the Reuben H. Donnelley Company in April 1907 attests to a C. F. Weeber Manufacturing Works advertisement in the "Jany issue Tel Directory" for \$3.

Bills to C. F. Weeber from the Postal Telegraph-Cable Company survive from the 1907-1910 period. Individual telegrams are itemized for the months of April, June, July, August and September 1909, when most messages were sent to New York City (64) and Detroit (30). Charges ran from \$.25 to \$.77 per telegram. The bill for April with 14 telegrams totaled \$4.41. In September twenty-six telegrams cost \$9.34. As will be seen below, Christian Weeber, as Ford agent during this time, communicated frequently both with the Ford branch in New York City and the Ford main office in Detroit. Other destinations for Weeber telegrams included Buffalo, Rochester, Chicago, Pittsburgh, Evansville, South Schroon, Cleveland, Hartford (Connecticut), Bridgeport and Brandon [sic].

Bills itemizing telegrams also survive for August, September and October 1910. Again New York City, where the factory branches of both the Haynes and Ford companies were located, was the primary destination for Weeber's telegrams, accounting for 55 of 71 sent or received. Other destinations were Detroit (4), Norwich, Chicago, Clayton, Saratoga, Syracuse (2), Glens Falls, Buffalo, Akron, Cincinnati (2) and Kokomo. Costs ranged from twenty-five to fifty-five cents.

Miscellaneous Operational Expenses

In 1909, Willis W. Griffin of Albany was a distributing agent for the Cresenola Soap Company of

Gloversville. A bill for two dozen soaps at \$.85 per dozen³⁷⁰ suggests that the Weeber Works provided soap for its employees' use.

A bill from W. H. S. Miner, a dealer in milk and cream with a branch at 28 North Pearl Street, indicates "C. F. Webber" was billed for "milk tickets" at a cost of \$2 per day on June 4, June 21, July 6 and July 24, 1906. Where the milk was delivered is not indicated on the Miner bill.³⁷¹



Following Christian Weeber's death, title to the property on Central Avenue was held variously by the First Trust Company, Waramaug, Inc., Henry Walk and John F. Walk. In 1944, the building at 170-172 Central was sold to the Hudson Valley Asbestos Corporation, which had occupied the premises by 1935.

In 1956, the Asbestos Corporation sold to George M. Spadaro and Austin A. Giuffre, who operated the Boulevard Appliance Company. Boulevard Appliance gave way to Teleservice Technicians, Inc. By 1978, the store was empty.

Eventually, all the former Weeber buildings, at 168, 170 and 172 Central Avenue, were demolished. The property became a garden for neighboring St. John's Evangelical Lutheran Church.

³⁷⁰The bill head, printed with the emblem of the Organized Soap Workers of America, is dated June 4 and marked paid by Griffin the same day.

³⁷¹The bill, dated August 1, 1906, was paid on September 5.



Figure 5.6: 170-172 Central Avenue, Albany, 1930s. Marion Weeber dated this image from 1933. The style of the console radios in the window suggests a somewhat later time. An incomplete pencil notation on the reverse (“44... front...”) indicates the print, only a portion of which is present, dates from a period of property transfer. The Hudson Valley Asbestos Corporation sold Stromberg-Carlson and Motorola radios for home and automobile use. Marion Weeber also noted “Machine Shop Upstairs Store Front Rented.” In the 1930s, Universal Auto Parts operated in the former Weeber building at 168 Central out of the picture to the left. A portion of the Emil Weeber bicycle shop is shown at the right. In 1942, 168 Central was vacant while the Weeber Cycle Works continued to operate. Photograph: Gift of Marion Weeber, NYSM Collection, H-1987.39.13.

CHAPTER 6. AUTOMOBILE DEALER

Christian Weeber selling automobiles of another manufacturer dates from 1906 or before. In early 1910, *The Sunday Press* said that the "first automobile industry in Albany was started in 1905" when the C. F. Weeber Manufacturing Works moved to Central Avenue.

The press stated while there were agencies for the sale of machines in the city before that, the Weeber firm was the first to go into the business exclusively. Supplies for automobiles were kept in stock and a general repairing business was begun.³⁷²

In 1917 *The Argus* claimed that:

With the advent of the larger manufacturers Mr. Weeber abandoned the work of manufacturing and turned to sales representative. This was in 1905. The concern moved to its present location on Central Avenue, where a most completely equipped show room was laid out and a machine shop fitted up. Here are shown [1917] the latest styles in Haynes, Standards and Allen cars.³⁷³

In August 1906, Weeber was identified as an automobile dealer ("C. F. Weeber, (Dealer)") by an *Argus* article describing the Albany Automobile Club's reliability run to Boston in June. While the report identified the drivers of specific cars, dealers in the event were only listed as participants without a specific connection to particular cars.³⁷⁴ Weeber also was identified as a dealer by

³⁷²March 6, 1910.

³⁷³February 18, 1917. Weeber was by no means the first automobile dealer in Albany. An earlier business handling cars made elsewhere, for example, was the Automobile Storage and Trading Company. Two years before the construction of the Weeber facility on Central Avenue, it was announced that Automobile Storage "have taken the Oldsmobile agency for 1903 for the following counties: Albany, Rensselaer, Montgomery, Fulton, Washington, Saratoga and Schenectady." See *The Horseless Age*, vol. 11, no. 5, February 4, 1903. The Michigan-built Oldsmobile was one of the more successful low-cost cars of the day.

³⁷⁴August 5, 1906. The makes of cars in the list of include Stearns, Peerless, Stoddard-Dayton, Maxwell, Knox, Locomobile, Winton, Columbia, Thomas, Franklin, Darracq, Cadillac, U.S. Long Distance, Pope-Toledo, White, F.I.A.T., Northern, Dedrick, Pierce, Ford, Oldsmobile, Brazier, Packard, Morse, Stevens-Duryea, Buick, Autocar and National. The only Ford

the Association of Licensed Automobile Manufacturers in October 1906 in a cover letter for the mailing of the *Standard for Hexagon Head Screws, Cast and Plain Nuts*. The Association distributed it in response to "so many inquiries from automobile dealers throughout the country in regard to the screw standard."³⁷⁵

It's possible that at this time Weeber still contemplated the fabrication of his own Weeber automobiles. In November 1906, *The Argus* identified six automobile garages in Albany and "one manufactory, the Weeber Manufacturing Company, [sic] on Central Avenue."³⁷⁶ A few weeks before, the paper noted that for 1907, the Central Automobile Company, in which Weeber was involved with Willard J. Sutherland at the same Central Avenue address as the Weeber Manufacturing Works, would have the agencies for both Maxwell and Ford cars, i.e., Weeber would be selling cars made by others.

The exact relationship between Weeber and Sutherland has not been determined here. No documents of their alliance survive in the Weeber collections at the New York State Museum. Nor do any records of incorporation exist in the Office of the Secretary of State. Clearly, the partnership in the Central Automobile Company and Weeber's own Manufacturing Works both operated until sometime in 1907 at 170-172 Central Avenue. Sutherland himself said their partnership lasted from 1904 to 1907.

An effort to distinguish between the affairs of the Central and Weeber Manufacturing businesses is suggested by surviving Weeber telephone records. Long distance calls made by "Sutherland" are documented in April and May 1907. On a Hudson River Telephone Company toll slip dated July 21 1906, a call from "West 460 Sutherland" to 694L in

was driven by G. A. Hubbard. One wonders if the "Dedrick" might have been a car operated by Weeber customer Archland Dederick

³⁷⁵Association of Licensed Automobile Manufacturers, *Bulletin No. 18* (Self-published: New York, 1906). The publication date is "July 1906." The cover letter, "To Automobile Dealers," is dated October 15, 1906.

³⁷⁶November 4, 1906.

Schenectady has a pencil notation reading "Central Auto Co." A bill to the Central Auto Company from the Utica Cycle Company, apparently for five rolls of tape, survives and is attached to the Weeber telephone bill for September 1907.

It was about that time, September or October 1907, the mutual or cooperative operations of the Weeber and Central companies ended. A bill from the Standard Oil Company of New York for gasoline delivered to the "C. F. Weeber Mfg. Co.—Successors to Cent. Auto Co." is dated October 3, 1907. More discussion of Christian Weeber's association with the Central Automobile Company follows in Chapters Eight and Nine.

Statements from companies providing materials for the C. F. Weeber Manufacturing Works operations as an automobile sales and service company in the 1900s, especially between 1907 and 1910, survive in the Weeber collection at the New York State Museum. These statements, along with handbills and correspondence from the same period, give insight into the operations of the Weeber Company and, by extension, other automotive retailers at that time. Invoices from 1909 are particularly numerous in the Weeber collection, giving a snapshot view of the retail automobile business at that time.

Tools and Equipment

Reference has been made to durable machinery acquired to equip the C. F. Weeber Manufacturing Works facility at 170-172 Central Avenue in 1906 and later. In addition, accessories for lathes and drill presses and hand tools were acquired. For example, in April 1907, the Weeber Works ordered 28 "S. F." [semi-finished] wrenches in sixteen different patterns for \$7.69 less 45% from the Billings & Spencer Company of Hartford, Connecticut. A year later another order was forwarded with requested material except "six semi[-]finished wrenches No. 268, which we are out of."³⁷⁷

Walter C. Gold, in Philadelphia, Pennsylvania, sold Weeber two Keystone Emery Wheels in October 1908. In May 1909, Gold wrote to ask Weeber "to look up your stock at this time." He enclosed a stamped envelope for Weeber's reply. In September 1909, Gold wrote again to tell Weeber

³⁷⁷The unsigned letter, dated March 31, 1908, concluded, "We would ask if we shall forward you these when in stock?" Weeber marked the letter "An[swer] 4/2."

that Robert A. Milne "is no longer in my employ. A new representative will call and see you in the course of a short time." In the meantime, Weeber again was advised to "look over your stock of Emery Wheels."³⁷⁸ Surviving Gold bills document Weeber's purchase of two six-inch Corundum wheels for \$3.05 each less 60% on July 21, 1906 ("Included in shipment to Thomas Stephens & Sons, Albany, N.Y."³⁷⁹); another Corundum wheel at the same price plus two Celluloid wheels at \$1.40 each less 30% on February 28, 1907; three Celluloid wheels at \$1.15 each less 30% on April 25, 1907; two Corundum wheels on August 15, 1907; and one unspecified, but probably Corundum, wheel at \$3.05 less 60% plus one Celluloid wheel for \$1.00 with no discount on June 22, 1909.

On April 23, 1907, the Weeber Company was billed \$4 for a Diamo-Carbo Emery Wheel Dresser shipped by mail from the Desmond-Stephen Manufacturing Company, makers of the dresser in Urbana, Ohio. The bill was paid on July 1, 1907.

Other types of tools offered to the Weeber Works in the 1910 period include Fulton hack saw blades from Montgomery & Company in New York City (as cheap as \$2.29 for the six-inch size in lots of ten gross or more at a time). The Weeber Works purchased a half gross of eight-inch blades, fourteen pitch for \$1.95 shipped via National Express on October 1, 1909. Grease cups might have come from the Bowen Manufacturing Company of Auburn ("...it has been sometime since you have favored us with an order for Grease Cups.").³⁸⁰ Based on a handbill for the Wells tool holder for lathes, Weeber considered purchasing such a device from Montgomery & Company. In May 1909, J. M. Warren & Company in Troy wrote concerning Vixen files recently sent to Weeber. "If you have tested these, we shall be very glad to have you report as to their merits. Will you kindly reply at your earliest

³⁷⁸Walter C. Gold to C. R. [sic] Weeber, Machinist, September 28, 1909.

³⁷⁹H-1933.6.682 in the Weeber collection at the State Museum is a stereotype of a November 10, 1906, testimonial letter on Thomas Stephens & Sons letterhead. Signed by Walter B. Stephens, the text praises the Weeber Shock Relievers "applied to my Model 'G' Franklin...I heartily recommend them." The Stephens firm was "builders and real estate agents."

³⁸⁰Two identical letters, the earlier signed by G. W. Severson, to C. F. Wheeler Mfg. Works, September 7, 1909 and to C. F. Wecker Mfg. Works, April 28, 1910.

convenience.”³⁸¹ Weeber noted “Write 5/18.” An undated letter from Olney & Warren of New York City accompanied a pamphlet about the Howard Grease or Oil Hanger. Olney was looking for “a live agent in your city.”

In 1908, the Weeber Works contemplated the purchase of a screw press, a device useful for pressing gears on to or from shafts. The firm of Manning, Maxwell & Moore in New York City responded to a Weeber letter dated January 25, 1908, by quoting prices for three different W. F. & John Barnes presses made in Rockford, Illinois. At \$65, \$100 and \$125 FOB (freight on board) New York, each press was subject to a 5% discount. With no response from Weeber, Thomas S. Stephens for the Manning firm wrote on February 29, 1908, “to have you advise us what disposition has been made of this matter and if we may hope to be favored with your esteemed order.” Weeber marked this letter “Ans. 3/2.” Whether he purchased such a press, certainly very useful in an auto repair shop, is unknown here.

In early 1908, Weeber returned a scale purchased from the Fairbanks Company in Albany in October 1907 for \$6.30. Weeber questioned a charge of \$.63, a 10% handling charge on the return. Fairbanks decided Weeber should not have been charged “and [we] are therefore this day crediting you with same.”³⁸²

In 1910, the Buffalo Foundry & Machine Company sent a booklet to Weeber and, in an accompanying letter, asked if the Albany firm might “be in the market for Steam Hammers.”³⁸³ The year before, Tate, Jones & Co., Inc., wrote to praise its heat treating furnaces that would produce a superior steel and allow Weeber to decrease the weight of its cars and the “percentage of breakage.”³⁸⁴ One assumes that Tate found an address for the Weeber Works in a list of auto manufacturers. In April 1908, the Chicago House Wrecking Company sent a broadcast letter to the Weeber Works asking if there might be interest in 6,000 to 8,000 gallon steel storage tanks that had “come off railroad

tank cars...carrying such products as Crude Oil, Naptha, Gasoline and other grades of oil.”

Consumable Goods (oil, gasoline, acetylene, etc.)

Oil

Between 1906 and 1911, a number of suppliers sold lubricating oil to the C. F. Weeber Manufacturing Works for which documentation survives. It should be remembered that internal combustion engines of the period consumed oil in a fashion quite unlike those a century later, where negligible amounts are lost between changes.

Lipscomb, Bleecker and Godley, on Hudson Avenue in Albany, billed for ½ barrel of heavy auto oil in July 1906 and May 1907 and an entire barrel in July 1907 at a total cost of \$43.60. The same firm provided a barrel of “special engine oil” in June 1906 for \$13.75, a bill paid in October. William R. Bleecker, “Successor to Liscomb, Bleecker and Godley,” sold ten gallons of “B & G. med auto oil” at \$.40 a gallon in June 1909.

The Standard Oil Company of New York, at 23 South Pearl Street in Albany, shipped six gallon cans of Mobil oil on October 1907 delivered via truck. The Weeber firm enjoyed a 30% discount from the total \$4.50 price. In May 1909, ten additional gallon containers were sold at 75 cents a piece also subject to a 30% discount. In August 1909, G. C. Van Deusen, of Standard Oil in Albany, wrote to adjust an oil price and also to request another invoice showing dates of this work as of August instead of April and June suggesting that Weeber was repairing Standard vehicles.

In April 1909, E. A. Tygert, “Consulting Engineers on Lubrication” in Philadelphia, Pennsylvania, sold the Weeber Manufacturing Works one barrel of “Motorlube medium” at 30 cents per gallon (\$16.35 total) shipped “Boat FOB [freight on board]” The Tygert billhead noted that the company was “Sole Mfrs. Of Motorlube Oil for Automobiles and Power Boats.”

The Brooks Oil Company in Cleveland, Ohio, shipped 53 gallons of Corliss Engine oil to the Weeber Works at \$.25 per gallon in March 1906; one case of auto oil at \$.30 a unit for a total of \$3.00 in June; and another barrel of Corliss engine oil in September 1906, the \$13.13 bill for which was paid

³⁸¹ “MOD” to C. F. Weber Mfg. Co., May 14, 1909. The question mark was omitted in the original.

³⁸² W. Emmons Starck [Stack?], auditor, to C. F. Weeber Mfg. Co., February 24, 1908.

³⁸³ E. G. Rippely, sales manager, to C. F. Weber Mfg. Co., February 10, 1910.

³⁸⁴ A. Siulson [illegible?], assistant sales manager, to C. F. Weeber Mfg. Works, May 26, 1909.

in January 1907. Correspondence in May 1909 regarding Brooks billing practices attests to continued Weeber purchases as of that date.

The Crescent Oil and Grease Company, also in Cleveland, responding to a mail order, shipped a gallon of "Franklin Auto Oil No. 1" gratis on June 15, 1909. Apparently pleased with the sample of Franklin oil, the Weeber company ordered a half-barrel (32 gallons) two weeks later and two and a half barrels at the beginning of July for a total cost of \$32.02. Another order followed in August. In September, the Crescent Company wrote that it was "in receipt of your order given to our representative, Mr. Sampliner, No. 532 for 25 barrels of Franklin Auto Oil, @ 28c per gallon." Weeber still was so pleased with the Franklin oil that the Crescent Company confirmed "agreement to give you exclusive sale of our goods in the city of Albany, N.Y." In addition to the 25 barrels, Crescent was shipping a barrel of No. 1 Franklin Auto Oil, a pail of No 2 Cotton Fibre Grease and one sign.³⁸⁵

With Weeber as an agent for his oils, B. F. Chandler of the Crescent Company wrote soon again to suggest, "Mr. Weeber we would kindly suggest to you that you carry our full line" of oils, numbers 1, 2 and 3. The last would satisfy those "people [who] want a heavier oil, like the Vacuum A..." The last was not as good as No 1 "but sometime you have to have it to supply the trade."

We are giving you liberal terms, and we think you could afford to carry a little stock on hand, so as not to be inconvenienced by being out of goods when called for.

We notice that you say in your letter to omit the brand and our name on the barrels. As per your request we will omit our name, but Mr. Weeber you do not need to be afraid that we will take away your customers, as we have hundreds of jobbers that we ship good direct to their people, and we would not under any consideration take their trade away, and when these people write to us direct, we just refer them to their jobbers, so you can sell the Franklin Auto Oil and rest assured that we will not take your trade away.³⁸⁶

One last Chandler letter survives from September 1909. In it, he acknowledges receipt of a check

³⁸⁵B. H. Chandler to C. F. Weeber Mfg. Works, September 2, 1909.

³⁸⁶B. H. Chandler to C. F. Weeber Mfg. Works, September 12, 1909.

for \$32.02 to cover invoices from June and July. He offers a "nice advertisement in the shape of a gasoline gauge. We will send you some ... Kindly let us know if you would desire to have your name on them, as it will make a very pretty add [sic]." Weeber marked the letter in pencil. "Write we should be pleased to have our name on them" and "wrote 9/28." A final surviving Crescent Company letter to Weeber from May 1911 acknowledges receipt of a check for \$78.24 to pay invoices dated September 1910.

The Great Western Oil Company, also in Cleveland, sent 2.5 barrels of Crown Motor Oil at \$.30 a gallon in April 1909. They subtracted \$1.50 from the \$19.80 cost of the oil, apparently since the seller had promised to cover the cost of shipping.³⁸⁷

In January 1908, Christian Weeber wrote to the Kendall Refining Company in Bradford, Pennsylvania, to request that oil barrels shipped to him not be painted with a brand name. The oil was intended for resale to Weeber customers. "O.K.," responded the Kendall firm saying:

This is what we understand you wish us to do in the future. We are perfectly satisfied that you will work up a nice business with this oil as it is the finest product obtainable from the Pennsylvania crude and we fully guarantee to maintain this quality. You should receive a good price for this high grade oil. Trusting that you will do a good business with this oil...³⁸⁸

Weeber noted in pencil on the Kendall letter, "Write that they did not comply with wish" and "Ans. 3/19." "O.K.," he responded on March 21, 1908, with regret for the error. "This was an oversight in the shipping department. On all future shipments we will make sure that the brand is left off as requested."

A Kendall order was shipped via the Buffalo, Rochester and Pittsburgh Railway for 2.5 barrels (62 gallons) of "Auto Oil #1 Red" at \$.35 a gallon on April 22, 1909. The extra barrel containers were sent free. The Weeber Company was given a \$1.12 shipping allowance, making the total due \$20.58,

³⁸⁷It's likely the oil was delivered with the shipping costs received on the spot from the Weeber firm. The bill is marked by hand "less Frt @ 32" and \$1.50 is subtracted from the \$19.80 selling price leaving the net cost of \$18.30, which was paid on July 8, 1909.

³⁸⁸"Dictated. O.K./F. D." to C. F. Weeber Mfg. Wks., January 31, 1908.

a sum paid in July 1, 1909. Meanwhile, on June 3, 1909, the Kendall concern wrote to offer a trial offer of oils and gasoline. Sunshine Premium Oil was 6.5c per gallon FOB railroad cars in Bradford. Deodorized gasoline was 10c FOB cars.

In May 1910, Weeber wrote the Kendall firm that, as paraphrased by "P.H." for Kendall, "purchasers of medium priced cars cannot afford to pay a high price for their supplies. We have had this in mind, however, and our prices for #1 Red and #1 Pale Auto oils have been very reasonable." The Kendall letter continued by noting, "until further notice" the price of those two oils was to be \$.30 per gallon in barrels and half barrels FOB Albany. The Royal Motor oil was only \$.20 per gallon. "As refiners, we are able to quote you closer prices than what you can secure through jobbers."³⁸⁹

In July 1909, the Hisgen brothers, proprietors of the 4 Brothers Axle Grease Company and the 4 Brothers Independent Oil Company, both in Albany, billed for ten gallons of Ruby Cylinder oil at \$.45 and ten pounds of transmission grease for \$.75 with ten pounds of "Extra Hard Transmission Grease" at no cost ("Free Corrected invoice"). The Hisgens offered two percent for ten days or sixty days net. Weeber paid in 65 days.

Christian Weeber apparently looked continuously for additional suppliers of oils and greases to distribute or sell at retail. In July 1909, he received a letter from the William C. Robinson & Son Company in Boston.

We understand that our Mr. J. R. Williams called upon you several days ago and took up with you the question of your handling our AUTOLINE in Albany. We understand that he agreed that if you would do so you would be the only one to whom we would offer it in your City, and we are writing to confirm his proposition to you, also the prices which he quoted, namely, if bought in small lots, 40c less 20% per gallon, and if bought in lots of 25 barrels or more per annum at 40c less 30% per gallon, FOB Albany.³⁹⁰

³⁸⁹"P.H." to C.F. Weeber Mfg. Works, May 12, 1910. On September 1, 1906, however, Weeber had purchased five gallons of #3 Royal Motor Oil at \$.25 per gallon and five gallons of #4 at \$.20 as well as twenty-five pounds of #3 Motor Grease at \$.08 and two 5 gallon cans at \$.65 from the Great Western Oil Company of Cleveland. The bill was paid on November 13, 1906.

³⁹⁰W. C. Robinson, president, to C. F. Weeber, July 20, 1909. Robinson noted that his oils were made from the best grade of Pennsylvania crude.

Robinson & Son noted that the company sold large quantities in various parts of the country "but have heretofore not pushed it in your locality." The Robinson firm had "no doubt that you can make a very good thing out of it..." and guaranteed "not to sell to any other person in Albany if you will accept our proposition." Two weeks later, Robinson wrote again. "Our Mr. J. R. Williams informs us that he has again called upon you in regard to our AUTOLINE, and wire, therefore, once more writing to know if we cannot interest you in the handling of our AUTOLINE, GREOIL, etc. in Albany."³⁹¹ Whether there was any additional correspondence between Weeber and Robinson is unknown here.

In 1910, Raymond Schulz of the Albany Cork Works was providing oil to the Weeber firm. On September 13, a half barrel (32 gallons) of Packard oil was sold from the Clinton Avenue supplier for \$9.60. Two weeks later another half barrel was supplied. Two extra empty barrels were sold at fifty cents each. The sales were rebilled on March 9, 1911, when the account was settled.

Other oil companies that solicited Weeber business in 1909-1910 included the Emery Manufacturing Company in Bradford, Pennsylvania (1909), the J. A. Seitz Company of Syracuse (1909), and the A. W. Harris Oil Company in Providence, Rhode Island (1910).³⁹² In 1909, the Havoline Oil Company of New York sought information about anyone offering the Weeber firm "Packard" oil. While Havoline was the sole authorized (by the Packard Motor Car Company) user of the Packard name. "We understand several different oil companies are claiming to manufacture 'Packard' oil... We would thank you to let us know if you have had any such oil offered to you, and if so, by whom?"³⁹³ While any reply to this request is unknown, Weeber placed an order with Havoline a few weeks later.

³⁹¹Edwin A. Robinson, manager of sales, to C. F. Weeber, August 5, 1909.

³⁹²The Harris firm sent a testimonial letter from the Benz Company in New York City praising the Harris oil used in the "12 0h.p." car raced in Florida. The Emery enterprise enclosed a testimonial from the Hewitt Motor Company in New York as well as a price list for oils and greases. J. A. Seitz, who signed the letter, noted that he could supply "anything you might wish in the various automobile line."

³⁹³L. S. Tainter, sales manager for the Havoline Oil Company, to Weeber Mfg. Wks., June 21, 1909.

Grease

Lubricating grease came from a variety of sources, such as the Penn Petroleum Company of Philadelphia, Pennsylvania, which supplied 200 pounds of grease for twenty cents per hundredweight in April 1907 and then a keg each of number one and number four grease and a barrel of machinery oil, all for \$20.30 in July 1907.

In August 1906, the New York & New Jersey Lubricant Company in Manhattan shipped via National Express twenty pounds of "Non-Fluid Oil" at \$.15 a pound. A typed note on the invoice said the price in fifty-pound cans was \$.12 a pound. The bill was paid in October. In August 1908, New York & New Jersey sent "As promised in ours of the 7th" new quotes on non-fluid oils. Dealer prices ran from \$.125 to \$.15 a pound, depending on container size with "Freight allowed to Albany, N.Y." In May 1909, Weeber received "Quotations for 1909 Season," covering "Non-Fluid Oils" and "MoToRol" oils.³⁹⁴

In February 1908, Christian Weeber received a trade price sheet for Albany Grease from Adam Cook's Sons in New York City. The price was \$.14 per pound for small quantities (cans containing one to fifty pounds). Barrels containing 400 pounds were \$40. The price list noted that the Cook Company maintained consumer prices offering "a splendid margin of profit in our Albany Grease for you." These end prices ran from \$.25 per pound in a one-pound can to \$48 for a 400-pound barrel. A Cook letter dated March 21, 1908, said that "Agreeable to the request of our Mr. Naughton, who called on you a few days ago, we are sending you under separate cover prepaid samples of our Nos. 0 & 1 Albany Grease for you to try."

In May 1909, Weeber wrote to United Manufacturers in New York City asking for samples of the A-#5 and K-#4 "Non-Fluid Oil." The United letterhead, in a reply dated June 4, 1909, is printed "N.Y. & N.J. Lubricant Dept." perhaps indicated that United was a successor to the New York & New Jersey Lubricating Company. In any case T. A. Matthews for United suggested that Weeber test both samples to see which would meet the need. A follow-up letter asking about receipt of the sam-

³⁹⁴Oil prices ranged from \$.29 to \$.47 per gallon to the dealers with end sales intended to range from \$.50 to \$.70.

ples is marked "no samples received," suggesting reference to a Weeber employee. Apparently Weeber himself wrote "write we did not receive" and "wrote 7/28 copy." In early August, United wrote to say they were tracing the missing samples but in any case were sending "by paid express, duplicate samples, which we trust will this time reach you without delay." By September, Weeber had placed an order for a "sample shipment of our 'K-#4' grade Non-Fluid Oil."

We were pleased to receive this order, for we are certain that you can develop a large and permanent trade on our Non-Fluid Oil among our customers, by pushing same. To aid you we are sending under separate cover, a supply of circulars like the enclosed, which please distribute among automobilists. . .

Please note that the retail prices on our Non-Fluid Oils, as shown in the enclosed circular are restricted. We insist upon their being maintained, and do not sell to dealers who cut prices.³⁹⁵

Albany Belting and Supply Company supplied ten pounds of "Albany Grease" in April 1909 for \$.15 a pound.

The Borne, Scrymser Company sent twenty pails (100 pounds) of "Hard Petroleum Grease" via the Peoples Line of Hudson River boats on May 19, 1909. On July 19, another 100 pounds in ten five-pound pails again went to Albany on the Peoples Line. Both shipments cost Christian Weeber \$.08 a pound. While both invoices offered a 1% discount for payment within ten days and asked for net payment within thirty days, each bill was paid about two months after shipment.

At some point, while Christian Weeber was a Ford agent or still servicing a number of Ford cars, he purchased a Runyen Grease Cabinet from the Warren Refining & Chemical Company.³⁹⁶ This device was designed for use with Varacity Lubricant, the grease dispensed through a hose by a hand pump that was part of the cabinet. The last paragraph of the Warren instruction sheet in the Wee-

³⁹⁵G. P. Holstein for United Manufacturers to C. F. Weeber Mfg. Works, September 11, 1909. The circular describes K000 oil for differential gears, steering gears, axles, universal joints compression cups, etc. as well as K-00 Special oil for transmissions. Prices ranged from \$.75 for a three-pound can to \$7.50 for a fifty-pound can.

³⁹⁶The "Warren" name suggests the Warren Refining & Chemical Company might have been located in Warren, Pennsylvania.

ber collection at the New York State Museum advises that "Garages handling Ford cars are enthusiastic about this Grease, because it is the only grease that remains in the differential and is not forced out on to the wheels from the end bearings of the main shaft." The next, and final two sentences, that have been marked by Weeber "Att." and circled in pencil, read, "Care should be taken that the transmission gear case should not be filled over two-thirds full. Otherwise the gears are obliged to force it out."

Gasoline

The Taylor Automobile Company on Orange Street in Albany sold the Weeber Manufacturing Works five gallons of gasoline at \$.18 a gallon March 24, May 3, May 11 and June 7, 1906.

In 1907, 1909 and 1910, gasoline in larger quantities was delivered to the Weeber Manufacturing Company by the Albany Department of Standard Oil Company of New York with an Albany operation on Van Rensselaer Island. In the spring and summer of 1909, most deliveries were via "TW1128," one assumes a tank wagon with a four digit identification number. The drivers were alternatively P. Laban, Snyder and Keal.³⁹⁷ The large quantities in 1909 suggest resale to end users, i.e., the Weeber Works operating as a retail gasoline outlet. The numerous charges from May and June 1909 were paid on August 12, 1909; those from August 1909 were paid on October 18, 1909. One assumes there were receipts now missing for gasoline supplied in July 1909. The quantities and prices documented by surviving invoices are presented in Table 6.1.

Acetylene

Before the mid-1910s, the most effective automobile headlamps used acetylene gas for fuel. A generator on the car could produce the acetylene by means of calcium carbide reacting with water. Or the motorist could purchase a supply of the gas compressed within in a portable tank that, when empty, could be refilled or exchanged for another.

³⁹⁷The Albany city directories for 1908 and 1909 show a Peter La Ban as an iceman and Maurenes Laban a driver. In 1908, both Charles Snyder and Fred W. Snyder were drivers. In 1909, Charles E. Snyder of Rensselaer was a driver.

The Weeber Manufacturing Works purchased calcium carbide from the Albany Hardware and Iron Company. Surviving invoices document that on July 17, 1909, Weeber bought three ten-pound cans at \$.70 each; on July 21, six more cans; and on July 30 a case of carbide for \$4.20.

The C. F. Weeber Manufacturing Works also did a lively business with suppliers of acetylene in tanks. Correspondence with the Milwaukee-based Avery Portable Lighting Company branch in New York City, beginning with a request for payment from Weeber in late 1907, is numerous in the Weeber collection at the State Museum, particularly with documents from the winter of 1908.³⁹⁸ At that time, the Avery letterhead included a list of "Recharge Depots" by locations in North American cities with Albany at the top.

A carbon copy of a typed, November 1908, letter from Weeber to "Mr. Avery" (E. C. Avery, secretary and manager of the New York branch), indicates that the two had negotiated at the Avery facility ("as stated while at your place") the cost of refilling tanks. In his letter, Weeber also notes the price he was planning to bill retail dealers for the recharges.

... we are to receive the size 40 [cubic feet] at \$1.15; size 60 at \$1.25; size 80 at \$1.75 less 5% the 1st or 10th of the month.

We will leave the figures just as they were given there, yet we have altered the prices to the dealer somewhat. The recharges are sold as follows: size 40 at \$2.50; 60 at \$2.75; 80 at \$3.50, and we add 40c transportation to each recharge, which would be \$1.65 to the size 40, \$1.90 to the 60, and \$2.40 to the 80, less 5% for ten days....

P.S. Please send us the recharges sent today by Monday night's boat, two new size 40 Tanks.³⁹⁹

The reference to the "boat" indicates shipment on a Hudson River steamboat line. Otherwise, transport of the tanks between Albany and New

³⁹⁸An invoice dated November 5, 1907, is for a copper Auto-gas tank at \$21 delivered from Albany. The Avery letter dated December 19, was mailed from New York. It asks Weeber's attention "to our statement of the 30th ult. [November] for \$22.25. This amount is past due and we presume that you have overlooked it. . ." Weeber marked the letter "Ans. 12/20 Check sent 12/20." The bill is stamped paid on December 23. The Avery letter is signed by the New York branch manager A. W. K. . . [illegible].

³⁹⁹C. F. Weeber Mfg. Works (unsigned copy) to "Mr. Avery," November 28, 1908.

Table 6.1: Invoices for gasoline purchases by the Weeber Manufacturing Company.

Date	Quantity	Cost per Gallon	Total for the Delivery
10/3/1907 ^a	110	\$.14	\$15.40
10/14/1907	80	\$.13	\$10.40
5/1/1909	45	\$.11	\$04.95
5/10/1909	105	\$.11	\$11.35
5/14/1909	65	\$.11	\$07.15
5/18/1909	65	\$.11	\$07.15
5/24/1909	60	\$.11	\$06.60
5/29/1909	110	\$.11	\$12.10
6/4/1909	85	\$.11	\$09.35
6/8/1909	70	\$.11	\$07.70
6/11/1909	70	\$.11	\$07.70
6/14/1909	35	\$.11	\$03.85
6/16/1909	30	\$.11	\$03.30
6/17/1909	45	\$.11	\$04.95
6/21/1909	50	\$.11	\$05.50
6/23/1909	30	\$.11	\$03.30
6/26/1909	75	\$.11	\$08.25
6/30/1909	100	\$.11	\$11.00
8/4/1909	70	\$.11	\$07.70
8/6/1909	25	\$.11	\$02.75
8/9/1909 ^b	35	\$.12	\$04.20
8/12/1909	105	\$.11	\$11.55
8/14/1909	30	\$.11	\$03.30
8/16/1909	40	\$.11	\$04.40
8/19/1909	55	\$.11	\$06.05
8/21/1909	110	\$.11	\$12.10
8/25/1909	55	\$.11	\$06.05
8/23/1909	35	\$.11	\$03.85
8/28/1909	65	\$.11	\$07.15
5/2/1910	60	\$.10	\$06.00
5/4/1910	65	\$.10	\$06.50
5/9/1910	100	\$.10	\$10.00
10/7/1910	80	\$.10	\$08.00
10/7/1910	60	\$.10	\$06.00

^aThe earliest bill notes the sale was to the "C. F. Weeber Mfg. Co.-Successors to Cent. Auto Co."

^bAn adjustment slip dated August 17, 1909, notes an "Allowance of 1c per gal on Invoice 8/9/09 35 gals. M. Gaso @ .01 35." Payment was received on October 18, 1909.

York was via the New York Central and Hudson River Railroad. Avery charged Weeber \$.52 for shipment of seven empty "gas drums" on January 11, 1909. Apparently the shipping cost of filled tanks was included with the price of the refill.

On January 20, 1909, Avery shipped twelve filled tanks, four of each size, via rail. The Avery invoice lists the serial numbers for each. A bill dated February 5 summarized the Weeber sales in January; a total of three shipments of filled tanks and charges for three shipments of empties, in all \$47.49. Weeber marked the bill "Pd."

In February, apparently as the Avery Company prepared to dispose of its business, Weeber returned some tanks permanently and received an Avery check as a refund on the deposits made for those tanks. For ten #40 and four #60 the total deposit was \$240.50 (\$16.50 for each #40 and \$19.50 for each #60). From the refund, \$13.30 was subtracted for fourteen keys, bands and unions.⁴⁰⁰ A few days later, Weeber sent Avery fourteen pairs of bands and four union connections, resulting in a credit memo of \$12.60. At the same time, he also returned one #80 (\$22.50), a #60 and four #40 tanks for an additional credit of \$123.25. Transportation charges to Weeber for the shipping of seven tanks and one box of hardware totaled \$.43.

The seventh tank, it turns out, was "Prest-O-Lite #38161," belonging to a competing supplier "but we are accepting it just the same as though it was an AUTOGAS #40." Avery added to his letter. "Our office will undoubtedly be open here until the first of March and possibly longer."⁴⁰¹ Further permanent returns followed, e.g., four #80 at the end of February. "When your shipment of these four tanks arrived it was in bad condition, one of the crates having been broken open and the bolts to one set of bands were lost."⁴⁰²

The Avery Portable Lighting Company continued to recharge tanks to the end of March, billing Weeber on the 31st for one #80 refill (\$1.75) and two #60 (@\$1.15 plus \$.45 for shipping on the Peoples Line. Christian Weeber marked the bill "Pd. 3/31/09". E. C. Avery's last letter in the Weeber

collection at the New York State Museum notes his visit with Christian Weeber the previous day. Whether in Albany or New York, somewhere other than at the Avery facility, is not clear. "Upon the writer's return here after seeing you yesterday:

... we are turning over our entire stock of AUTOGAS TANKS to the Commercial Acetylene Co. today [March 31, 1909], consequently we will be unable to supply you with any more recharges. You, of course, understand the position taken by the Prest-O-Lite Co. in relation to supplying their tanks in exchange for AUTOGAS.⁴⁰³

An Avery document in the Weeber collection is a broadside dated May 10, 1909 advising "Automobile Dealers and Owners" that a former employee doing business in Chicago as the Autogas Recharging Company was a former bookkeeper who had "gained no practical knowledge whatever of making or refilling Autogas tanks." Incidental to the subject of the broadside but germane here is the statement that "we have discontinued making or recharging Autogas tanks, having disposed of our business to the Commercial Acetylene Co. of New York."⁴⁰⁴

A final letter from the Avery Portable Lighting Company of Milwaukee is dated June 8, 1909. It accompanied a bill dated April 1, 1909, for \$81.15, "the amount due us from you according to the books of the New York Branch, which were recently turned over to us for final settlement." The letter is signed by A. W. Kaeshuer who, in 1907, had been manager of the New York branch. Weeber marked the Avery letter in pencil with some of his notations crossed out. "Look up receipts & write today Matter is settled Wrote Copy 6/16."

At the beginning of 1910, Weeber still had some Autogas tanks on hand. Sending them to the Marion Acetylene Specialty Company in Jersey City, New Jersey, for recharge, he had them returned empty via the Adams Express Company. Although the Acetylene Specialty letterhead claimed, "We repair all tanks at lowest prices" and "We recharge acetylene gas tanks of every description," the four tanks were being shipped empty since they did not comply "with specifications of railroad requirements as per enclosed SPECIAL INFORMATION

⁴⁰⁰Avery to Weeber, Mfg. Works, February 16, 1909. An Avery letter the previous day accompanied a check for \$139.81, a refund also for ten #40 and four #60 tanks less the January charges (\$47.49 less 5% and \$2.80 for fourteen keys and unions).

⁴⁰¹Avery to Weeber Mfg. Works, February 20, 1909.

⁴⁰²Avery to Weeber Mfg. Works, March 3, 1909.

⁴⁰³Avery to Weeber Mfg. Works, March 31, 1909. The author does not know what arrangement the Prest-O-Lite concern made regarding AUTOGAS tanks.

⁴⁰⁴The heading reads, "Milwaukee, Wis., May 10, 1909."

concerning railroad rules and regulations for safe transportation of inflammable gases."⁴⁰⁵

Marion Acetylene, and its predecessor Acetylene Gas Specialty Company, had recharged tanks for Weeber in 1909. In April there was one #40 @ \$1.15 and three #60 @ \$1.40 for a total of \$5.35. Another \$.25 charge was added for the "Amount paid to Peoples Line on arrival of the tanks (Hudson Nav. Co. receipt encl)," indicating shipment by boat in both directions. In early May, one #80 @ \$1.90, three #60 and one #40 tanks were filled. An additional \$.25 was billed for freight paid to the Peoples Line on receipt of the tanks by Acetylene Gas Specialty. Paying within ten days, Weeber subtracted 5% (\$.37) from the billed amount. In late May one #80, five #60 and two #40 were also billed. Again, there was a sum of \$.64 for "paid charges on receipt of tanks." The bill is marked in ink, "Thanks for promptness." Weeber had subtracted 5% (\$.58) from the total. And in early July a bill, now from the Marion Acetylene Specialty Company, invoiced for the recharge of two #60 tanks and two #40 tanks shipped by rail.⁴⁰⁶

Apparently, for his acetylene recharge business, Weeber eventually turned to the branch at 1904 Broadway in New York. (Avery had been at 243-245 West 57th Street "near Broadway.") As early as June 1909, Weeber had attempted to purchase a Prest-O-Lite tank from the New York Sporting Goods Company at 17 Warren Street in Manhattan, but the order could not be filled: "We have over fifty of them on order with the factory but they cannot deliver a single one."⁴⁰⁷ In September 1909, he received notice of a backorder for two Style B Prest-O-Lite tanks from the Motor Car Equipment Company at 55 Warren Street in New York City. "... the Prestolite people and [are] not making any deliveries and do not know when they will, as they have not sold any tanks for the last three months."⁴⁰⁸

⁴⁰⁵C. Bournemille for the Marion Acetylene Specialty Company, January 17, 1910.

⁴⁰⁶The filled tanks were "Shipped this date [July 9, 1909] via Adams Express."

⁴⁰⁷H. T. Fowler for the New York Sporting Goods Company, June 9, 1909. A telegram dated May 28, 1909, from the Acetylene Gas Specialty Company in New York, suggests an interim if not an alternative recharge arrangement there in the post-Avery period: "Tanks only rec'd last night will be shipped tomorrow morning."

⁴⁰⁸L. L. Waldman for the Motor Car Equipment Company to C. F. Weeber Mfg. Works, September 18, 1909. The order also

As early as April 1909, Weeber paid the Prest-O-Lite Company for three "tank cases "B" [filling thereof]" at \$2 each less 5% for prompt payment and in May 1909 for a \$1 tester. Within a short time, Weeber himself was a Prest-O-Lite dealer. An undated Prest-O-Lite flyer among his correspondence suggests dealers recommend that owners of larger cars switch from the 40 cubic foot Style B tank to the 70 cubic foot Style A. The retail cost of the larger tank was \$50; "price to you [dealer] \$35. Retail recharges \$3.00 in New York; price to you \$2.00." Another Prest-O-Lite mailing announced "for the convenience of car dealers...small newspaper advertisements, copies of which we enclose." The sample ads showed a "Motorcycle Size" acetylene tank, "A Handy Reserve Supply for Autos" and other Prest-O-Lite products. The cuts are free. "Order all five cuts if you can use them."⁴⁰⁹ Whether Weeber did is not known here.

On two occasions in 1909, the Weeber Works purchased "gas tank box"[es] for \$3 each from the 35% [sic] Automobile Supply Company at 97 Chambers Street in New York. The bill heads are printed, "You Save An Average Of 35% When You Buy From Us... 35% Automobile Supply Co. New York."⁴¹⁰ Gas tank boxes, according to a New York Sporting Goods Company catalogue for 1909, were "made for 20 in. gas [acetylene] tanks and have openings for pressure registers. These cases do away with the necessity of unfastening tank bands to exchange empty for full tanks and prevent collection of mud or corrosion on the tanks."⁴¹¹

Hard Goods (Repair Parts, Accessories)

General Supplies

Several catalogues in the Weeber collections were created by supply houses for comprehensive offerings of general automobile parts, equipment and supplies. The Post & Lester Company of Hartford, Connecticut's *Motor Car Supplies 1907*, previously

included "two small folding chairs." Weeber noted, "write to cancel all 9/21."

⁴⁰⁹The cover flyer, dated January 10, 1910, is signed by M. R. Burlingame, advertising manager.

⁴¹⁰The invoices are dated June 7, 1909 (paid on June 14) and July 15, 1909 (paid on July 24).

⁴¹¹Catalogue no., 41, p. 35. H-1933.6.198A-B.

mentioned, claimed the firm was “The Largest Mail Order Motor Car Supply House in America.” Also, as noted before, the Weeber Shock Reliever and Weeber Valve Tool are displayed among the 112 pages, showing a wide variety of auto-related equipment and accessories, even injection pumps for steam-powered cars.

The *Catalog of Automobile Supplies '08* was a 96-page publication of the Motor Car Equipment Company of New York.⁴¹² This “Annual Encyclopedia of the Best Imported and Domestic Automobile Accessories” intended for end consumer use does not list any Weeber products; as has and will be seen, the C. F. Weeber Manufacturing Works purchased a variety of supplies from Motor Equipment.

The Weeber collection includes a Motor Car Equipment “Export Price List,” dated April 1, 1908, “to be used in connection with illustrated catalog.”⁴¹³ Discount prices “allowed to legitimate dealers in Automobile Supplies only” are shown side by side with the list figures. For example, a \$40 Jones speedometer would cost a dealer \$30. The Weeber collection also has a *1909 Wholesale Catalogue of Automobile Specialties* sold by the Motor Car Equipment Company. This 41-page booklet has no Weeber specialties in it. A rubber stamp noted that a more comprehensive, 136-page catalogue would be sent upon receipt of \$.10 for postage.⁴¹⁴

A 1909 catalogue came from the Phoenix Auto Supply Company of St. Louis, Missouri. This 144-page, soft-cover *Catalogue No. 5* was intended for retail, mail order sales. A laid in “Phoenix Special Snap Sheet No. 18” noted, “Large Discounts to Dealers.”⁴¹⁵ A check of the Phoenix pages revealed no listings of Weeber products.

An undated copy of a catalogue titled *Motor Accessory Magazine* likely was distributed by United Manufacturers in New York City in 1909.⁴¹⁶ A selling cooperative, comprised of Jones Speedometer, C. A. Mezger, Inc., Connecticut Telephone and Electric Company, Weed Chain Tire Grip Company, New York and New Jersey Lubricant Company and United, made its offices in the Jones Speedometer Building on Broadway in New York.

⁴¹²H-1933.6.186.

⁴¹³H-1933.6.266.

⁴¹⁴H-1933.6.304.

⁴¹⁵H-1933.6.230.

⁴¹⁶H-1933.6.307. The 1909 date is based on correspondence Weeber had with United in that year.

The Weeber Manufacturing Works’ dealings with United Manufacturers about speedometers (Jones), windshields (Mezger) and lubricants (New York and New Jersey) are discussed in other sections of this book.

Lamps

In the period before electric headlamps were fitted to cars at the factory, lamps often were accessory items purchased separately. Consequently, the C. F. Weeber Manufacturing Company dealt in lamps and lamp repair and supplying acetylene for its customers.

One of the major makers of automotive lamps was the Badger Brass Manufacturing Company of Kenosha, Wisconsin. In April 1908, the Weeber Works ordered three pairs of Solar Headlights from the Badger main office, which referred the order to the Badger Eastern Branch in New York City. Two months early, the New York Sporting Goods Company had written Weeber to note, “that your order given to our Mr. Crook, reads \$6.60 each. This is the very best price we can make on these lamps and we could not entertain your order at any other price. The price \$6.60 is the best price that the Badger Brass Company can give anyone ordering 100 lamps.” Weeber noted on the letter, “Call Mr. Nichols about this,” “Ans. 3/5” and “order 7 lamps.”⁴¹⁷ In June 1909, the Weeber Works purchased two oil pots and burners for “#726 lamp repaired” for \$1.75 and one oil pot and burner for a #605 lamp. The latter was discounted 50% to \$.75 to which was added \$.16 for postage. In 1909, Weeber purchased ten Solar headlights #956-A from Badger at \$5.20 each.⁴¹⁸ An impressive *Solar Lamps* catalogue for 1909 is part of the Weeber collection at the New York State Museum. Consumer prices listed include that for the 956A at \$8.⁴¹⁹

In April 1908, the Atwood Manufacturing Company of Amesbury, Massachusetts, wrote the Weeber firm to offer headlamps and generators “left over the first of the year.” For headlights retailing at \$32, Weeber was offered a price of \$10 or \$11

⁴¹⁷James E. Murray, secretary of the New York Sporting Goods Company, to C. F. Weeber Manufacturing Works, February 25, 1908.

⁴¹⁸Four lamps were shipped from New York via American Express in July (invoice dated July 14) and six from New York in August (August 23).

⁴¹⁹New York State Museum collection, H-1933.6.178.

per pair according to model. The \$12 gas generators could be purchased for \$5 FOB Amesbury. The Atwood letter, enclosing a broadside showing the merchandise, said it had twenty-five pairs of headlights and twenty-five generators available.

Another seller of lamps was the Saxon Lamp Company at 530 W. 28th Street in New York. Weeber had purchased three tail lamps at \$1.80 each in October 1907. In December, a Saxon letter reminded Weeber that when "the writer saw you at the Grand Central Palace [auto] Show your Mr. Weeber promised that as soon as he had gotten back to Albany and looked around he would send us in a sample order for a pair of headlights such as suggested, namely #56 which is a very suitable lamp for Ford Runabouts, but so far we have not heard anything from you on the subject and therefore trust that upon receipt hereof you will look into same and advise us as to what you have decide upon and oblige."⁴²⁰

The Edmunds & Jones Manufacturing Company of Detroit was another well-known maker of lamps, called the E. & J. line. In October 1907, the Weeber Manufacturing Works purchased two #60 gas lamps at \$5.50 each; two #3 oil side lamps at \$3 each; a #1 tail lamp at \$2.75; and an acetylene generator at \$4.75. In short, it was a complete lighting outfit for one automobile.⁴²¹

The Post & Lester Company, general suppliers of automobile parts and accessories, sold the Weeber Manufacturing Works two pairs of "Royal DE [sic] Lux Headlights #196R" in August 1909 for \$17 total.⁴²² The New York Auto Lamp Company sold Weeber three pairs of "101-6¼" Extra flare" @ \$6.48 and a "200 Tail Lamp @ \$1.85 on August

⁴²⁰H. Saxon to C. F. Weeber Mfg. Works at 53 Bradford Street, December 13, 1907. Weeber noted on the letter, "An 12/14" without indicating the nature of the reply. The Saxon invoice for the three tail lamps shows the goods were shipped via American Express. And that payment was receipted by C. J. [or "T" illegible ?] Greenberg on December 16, 1907.

⁴²¹In May 1909, the Weeber firm purchased a \$.90 "#4—A fount comp" for \$.90 to which invoice \$.016 was added for postage by the Edmunds & Jones Company.

⁴²²This bill was marked paid on September 23, 1909, the same day as Weeber settled a July 21, 1909, charge for six boxes of cotter pins (\$.60); six boxes of lock washers (\$1.50); six gas bags (\$.68); and twelve "Brays Improved patent Elta Gas burners" (\$.3.00). On April 3, 1909, Post & Lester billed a charge of \$2.75 for a door for a "60 F lamp like-illustration", which Weeber marked paid on June 14, 1909 on the invoice.

31, 1909.⁴²³ A handbill in the Weeber collection at the State Museum touts the Adlake automobile lamp, an acetylene device available with two different carbide generators. The manufacturer was the Adams & Westlake Company of Chicago, New York and Philadelphia.⁴²⁴

Weeber purchased from the Pittsburgh Lamp, Brass and Glass Company generators that use calcium carbide with water to produce acetylene. On July 9, 1909, Pittsburgh Lamp telegraphed, "Will ship Generators next Monday." On July 12, in response to mail orders,⁴²⁵ invoices from Pittsburgh, document three #93 gas generators shipped at \$6 each; along with one #93½ at \$4; and two rubber gaskets for gas generators at no charge, all in a box for which Weeber was charged \$.50. Three more number 93½ generators were billed on July 27. Three gaskets for "Large Generator #93" were sent by mail for no charge on August 20, 1909. Pittsburgh wrote on September 15, 1909 that it could "ship #93 Generators within a couple of days... Trusting we may be in receipt of your order, we remain."

A few weeks earlier, the Syracuse Rubber Company had written to say they sold the Pittsburgh Generator under the Reliable name. The #93 was the large size available to Weeber at \$5. He noted on the letter "Ordered 8/14 Copy." Apparently another hand wrote in pencil, "Order three + write Pitts Co to Cancel order." However, Weeber returned the Syracuse "Generator because it did not have running board attachment." Syracuse Rubber responded with a letter noting, "we can furnish you with generator, same price with running board attachment. Your order did not state which one you want in in [sic] this case we always send side attachment."⁴²⁶ Nevertheless, the Weeber Works turned elsewhere and by letter purchased the #93 with running board bracket for \$6 total from the Bi-Motor Equipment Company of Boston. The invoice is dated August 27, 1909. Apparently pleased with the Bi-Motor's service, Weeber bought an-

⁴²³The New York Auto Lamp invoice also billed for three 40" horn tubes; 12 [horn] reeds; three #12 bulbs; and three #14 bulbs. The total bill was \$26.66, paid on October 16, 1909.

⁴²⁴H-1933.6.227.

⁴²⁵The Pittsburgh Lamp invoices in the blank line following pre-printed "Salesman" have the typed word "Mail."

⁴²⁶H. Howlett for the Syracuse Rubber Company to C. F. Weeber Mfg. Co., August 21, 1909.

other #93 generator on August 31, 1909, paying for both on October 8.

Other running board generators in the summer of 1909 came from the Wilson Trading Company of New York (two running board generators at \$4 each plus three #9 pumps at \$.90 each) billed on July 12; and "3 large #45 Generators with running board bracket large \$4.95" from the Beckley-Ralston Company of Chicago. These items, billed on August 8 were shipped "Via Fcty." On July 20, 1909, the Albany Hardware and Iron Company sold the Weeber Works a "Solar Generator #11" for \$6.75 and two "Style B Gas Tanks" at \$17.50 each. In short, there was a lively Weeber trade in acetylene generators in summer 1909.

Miscellaneous equipment for gas lighting systems included rubber hose to carry gas from a generator or supply tank. In April and May 1909, Weeber bought hose from the Albany Rubber Supply Company for \$1.97. Then in July he purchased 100 feet of rubber lamp tubing from the Albany Hardware and Iron Company for \$4.50.⁴²⁷ In November 1907, Weeber paid the H. W. Johns-Manville Company of New York \$3.75 for a reel of ¼" Canadax wicking for oil lamp use at \$.15 a pound.

Repair parts for lamps also were a Weeber need. In 1907, the Weeber Works purchased two 8½" bevel glass front panes for a #72 lamp from the Manhattan Screw & Stamping Works, makers or distributors of the Phoebus automobile lamps.⁴²⁸ Also in 1907, the Weeber firm purchased "two only Dietz Lenses for Orient 1906 Lamps" at \$.50 each, discounted 25% from the R. E. Dietz Company ("The Largest Manufacturers of Lanterns in the World") in New York. The bill notes a discount of \$.04 for payment within ten days. The bill is dated December 10, 1907, and, uncharacteristically quick for a Weeber payment, was marked paid on December 12, 1907.⁴²⁹

⁴²⁷All Albany Hardware bills for July 1909 purchases, including those for carbide mentioned above, as well as for a pair of Weed chains at \$11 discounted 25%, were paid on September 23, 1909.

⁴²⁸The invoices for the glasses are dated October 25, 1907, when the charge was \$.35 (and a generator basket apparently was sent at no charge) and November 22, 1907, when the charge was \$.45. Shipping was via express. Payment of both bills was received on December 30, 1907. The Manhattan bill heads note the manufacture of "Metal Goods. Turned Parts, Metal Stamping, Rolled Thread Products. Some of Our Specialties" in addition to "Phoebus Lamps" for automobiles.

⁴²⁹Shipping was via American Express.

In 1909, Weeber purchased a 7½" mirror (the author assumes a reflecting mirror for the back of a lamp) from Gray & Davis, makers of carriage and automobile lamps in Amesbury, Massachusetts. The charge was \$4.75 less 25%. The same day, August 27, another mirror, a 7" type, was returned to inventory and Weeber credited with \$3.57. Then on August 30, apparently a third mirror, a #71, was sent to Weeber also at \$3.57, which was paid on October 23, 1909.

The Weeber firm commissioned lamp repairs it did not undertake itself, sending, for example, a lamp to the Rose Manufacturing Company in Philadelphia in the summer of 1907.⁴³⁰ Also in 1907, the Manhattan Screw & Stamping Works repaired two lamps using one replacement front door, one clear glass, two ruby glass panes, a ring for one of the ruby glasses and two burners. Thirteen hours of labor were expended resulting in a total bill of \$7.75.⁴³¹

In May 1909, the Atwood Manufacturing Company ("Coach, Automobile and Carriage Lamps in Great Variety") in Amesbury, Massachusetts, repaired, "1 Flange" for \$1 and charged \$.26 for postage. A door was to "go forward via express tonight," on August 9, 1909, from the C. T. Ham Manufacturing Company, a lamp maker in Rochester. The invoice for the repair included a front door glass for \$.50 and a half-hour's labor at \$.25. Shipping was via National Express. With a 2% discount for payment within ten days, Weeber's cost was \$.74. Also in 1909, the Weeber firm shipped a search light to the auto parts supplier Post & Lester in Hartford, Connecticut, for repair. Post & Lester wrote to state that, "we have ordered a lens from the factory which we expect will be received in a day or two. We will then make the repair promptly." Two weeks later Post & Lester wrote again, one assumes about the same matter. "We are in receipt of your request of the 24th asking us to cancel your order, but we are unable to

⁴³⁰The surviving Rose invoice is only for "Expressage on lamp rec'd for repairs 7/5/07" with no record of any repair work done. The shipping cost was \$.65. The invoice is marked in pencil, "Send Stamps" and the bill is marked paid on September 7, 1907. Rose Manufacturing was the source of "Neverout Patent Motor Lamps."

⁴³¹The invoice dated May 13, 1907, was stamped paid on June 25.

do so as the goods were forwarded to you several days ago."⁴³²

In 1909, a pair of six-inch lamps was shipped to the C. M. Hall Lamp Company in Detroit. Unfortunately:

We find these lamps so badly damaged that we are unable to put them in perfect shape, without the use of new parts. As we are unable to secure these parts, due to the fact that the American Lamp Co., has closed out their business, and as our parts are not interchangeable with their make of lamp, we are absolutely unable to do anything for you in the way of repairs.⁴³³

Electric lighting began to be used in automobiles in the 1900s. If not for headlamps, then at first electricity powered side, tail, dashboard or interior lamps in some vehicles. A promotional letter to the "Webber Automobile Wks [Works]" in 1910 claimed, "Today nearly as many cars are using electric side lights as are using oil side lights and electric headlights are rapidly coming into use." Consequently the Willard Storage Battery Company of Cleveland wrote to see if the Weeber organization might be interested in becoming a selling agency for the ELBA Auto Lighting System. "Do you want us to consider you in your territory?"⁴³⁴ There is no notation of a Weeber reply on the Willard letter.

A few years later, as electric lighting replaced gas on new cars, the Apple Electric Company of Dayton, Ohio, marketed the Aplco Automobile Electric Lighting Systems. A July 1913 "Bulletin No. 36" in the Weeber collection at the New York State Museum was a "Book of Suggestions for Installing" the Aplco system.⁴³⁵ Primarily, the booklet presents photographs of Aplco retrofit installations on a number of different makes of cars—although none on Haynes or Studebaker autos, the two makes the Weeber Works were selling at that time. Whether Weeber installed any of these Apple dynamos (generators) driven by roller chain from a convenient shaft on a subject car is unknown here.

⁴³²"M" for the Post & Lester Company to C. F. Weeber Mfg. Wks., September 15, 1909; to the C. F. Weber Mfg. Co., September 28, 1909.

⁴³³W. F. Auklaer? [illegible?], assistant general manager, to C. F. Weber [sic] Mfg. Works, September 23, 1909. Weeber noted on the letter, "write to return" and "wrote 9/28 Copy."

⁴³⁴G. L. Chandler for the Willard Storage Battery Company to Weeber Automobile Wks., April 18, 1910.

⁴³⁵H-1933.6. 274.

A July 1909 response from the American Ever-Ready Company to a Weeber query concerning a bulb for a flashlight suggests the possibility that Weeber was selling, or contemplating selling, such innovative handlights, perhaps for use around automobiles.⁴³⁶ A broadside toting Melchlor Batteries, "a wonderful achievement in the manufacture of small dry batteries" for portable lights that "will become staple articles," followed from EverReady a year later. The reader of the broadside was advised to "order now. You can make a handsome profit in selling them."⁴³⁷

Tires

In the 1900s, tires were short-lived objects requiring frequent repair and replacement. (Discussions of them might well have been placed with consumable substances, such as gasoline and oil.) The correspondence file about tires is considerable in the Weeber collections at the New York State Museum. The bills for tires sold to, or repaired for, the C. F. Weeber Manufacturing Works comprise the largest segment of the invoices surviving from the last years of the 1900s.

The earliest documents of the Weeber tire business are price lists from the 1905 period. A Fisk Rubber Company, of Chicopee Falls, Massachusetts, retail price list is dated January 1, 1905.⁴³⁸ An Albany Rubber Tire Company invoice from August 31, 1906, is for a "Fisk Case 3½ x 32 Tube 1 Mould" with a list price of \$3.50 discounted 25%. Morgan & Wright of Detroit were early makers of auto tires; an "Auto Sundry Price List" with a laid in dealer price list dates from 1907.⁴³⁹

Among the makers of tires purchased by the Weeber firm was the B. F. Goodrich Company of New York. Goodrich invoices noted that shipment was from Reade Street in Manhattan but that payment was to be made to "Our Branch in Akron, Ohio." Surviving bills from November 1907 as

⁴³⁶P. D. Seaborn to C. F. Weeber Mfg. Works, July 19, 1909.

⁴³⁷W. G. Mills, sales manager, American Ever Ready Company, February 17, 1910. On August 9, 1909, Mills had sent a broadside noting the increase in price of two miniature bulbs to \$.60 (net to the trade \$.405) due to the cost of manufacture. "It is the smallest lamp of its character manufactured, and the most skillful help must be employed on same."

⁴³⁸H-1933.6.324. The handbill notes, "Pump and Repair Outfit with each set of four tires." Prices for a "complete tire" ranged from \$23.10 to \$92.50 depending upon size.

⁴³⁹H-1933.6.396 A-B.

well as June through October 1909 show multiple purchases of tires and tubes together and separate orders for tires and tubes. Shipping was express collect, sometimes from the Adams Express and National Express companies, but usually from the American Express Company. Discounts varied by product from 5% through 10% to 20%. An additional 5% was subtracted for payment by cash within ten days. The earliest bill, from November 12, 1907, shows a charge of \$30.75 for a regular smooth tread 28" x 3" tire; \$6 for one tube; and \$8.25 for another. With discounts, the billing amount was \$30.78. With payment on November 21, another \$1.54 was removed, making the final cost to the Weeber concern \$29.24.

By 1909, the same size tire was less than \$15, although this may have been for a different style. The most expensive tire listed for \$49.55, a 36" x 5" smooth tread case, shipped on June 1, 1909. The Goodrich Company also provided generator tubing for acetylene lighting systems; 44 feet of tubing cost \$2.60 in 1909. In all there are seventeen Goodrich invoices in the Weeber collection at the New York State Museum. A photograph of the interior of the Weeber showroom in 1909 or 1910 shows a "Goodrich Automobile Tires" sign (and two for Fisk tires), indicating that the Weeber Works was a Goodrich tire dealer.

Letters from the Goodrich Company to the Weeber Manufacturing Works concern such subjects as: the repair of a tube that the Goodrich inspectors said blew out because of it "having been pinched in the case [tire]" and which Weeber wrote to have repd. [repaired]; the different size tires that could be mounted on a given rim, e.g., "36 x 4½, 36 x 5 and 37 x 5 all fit on the same rim;" a charge of \$35.40 that Weeber thought was a double billing; and a bill sent to the Weeber Manufacturing Works in error "inasmuch as this charge of April 12th [1909], \$1.65 was rendered to the Weeber Cycle Works."

In November 1907, the Weeber Manufacturing Works sent a package with shipping charges due to the International Rubber Company in Milltown, New Jersey. A letter from H. K. Felton at the tire company advised that they would accept "no goods for repair or replacement unless charges are prepaid." Weeber was advised to pay the shipping costs "and at the same time write us fully in regard to it." A pencil note in Weeber's hand reads, "Ans.

11/25 Please deliver free & chg same to us CFWeeber O.K. please Expense O.B. Matteson."⁴⁴⁰ On December 2, 1907, Felton wrote that, "As it [the tire] has worn through the rubber to the fabric without any signs of being defective in any way we see no reason why it should not be recovered at the regular price of \$7.75." The Weeber firm was asked to advise on the proposed repair and someone noted in pencil on Felton's letter, "Answered 12/4." Whether there was a problem with that tire or another, a final Felton note from January 24, 1908, said in reply to a Weeber letter from the previous day, "We will adjust the matter by sending you a retreaded 28 x 3 Casing at a special price of \$6.00."

Twenty-two invoices and seventeen letters from the Firestone Tire and Rubber Company survive from late 1907, 1908 and 1909. The invoices are for purchases of tires and tubes. Shipping, when noted on the invoices, was via express. Shipment from the New York branch was noted on the forms. One assumes the remaining shipments were from the Firestone factory in Akron, Ohio. Most tires and tubes were in the 28" x 3" and 30" x 3½" in. sizes. Pencil notations on many of the invoices record a 5% discount from the printed, one assumes, dealer prices, although the earliest, December 6, 1907, invoice, for a 30" x 3" clincher case and tube shows a 30% printed discount in addition to the 5% marked in pencil. Shipments with no charges include two clincher tube replacements, a "Clincher Case Repaired, Retread" and another clincher case repair. A replacement clincher case was shipped at the "Spl. Price a/c replc." of \$6.75 in 30" x 3" size. A set of two retaining rings and twelve bolts with nuts was shipped via American Express from Akron. Perhaps the incorrect fasteners were sent or not enough of the appropriate parts. A week later the Weeber Manufacturing Works received a half set of bolts and nuts for 32" x 3 ½" demountable rims at no charge.

Firestone correspondence was concerned with new products, price increase and, chiefly, with adjustments to charges and discussions of repairs to tires and tubes sent to the New York branch

⁴⁴⁰The 1907 and 1908 Albany city directories list Otis B. Matteson as an agent for the National Express Company. He resided on Pine Avenue.

for possible work. On July 6, 1909, for example, Firestone wrote that a defective tube would be replaced without charge and a tire could be retreaded. "...undoubtedly due to the cause which you mention and inasmuch as we have no doubt that the trouble is remedied in the underset of the axle, we are willing to retread the present case without charge and will give it this treatment and return to you promptly."⁴⁴¹

On the other hand, the same writer on the same day declared that upon inspecting a tire, "We judge [it] has run upwards of 3,500 miles. This casing has five nail punctures and a ½" cut through it, the tread being worn entirely through to the breaker and the case is beyond repair." Weeber, or someone else, noted on the letter, "...ordered new 36 x 4 Ans. Copy Barzen tire Out of town Phone to Barzen." Firestone wrote again on July 23 to acknowledge the order for a new regular clincher casing. Apparently, in response to a question from the Weeber Works, the unsigned Firestone letter said that the only allowance for the old tire was as scrap since it had given the maximum guaranteed mileage. A credit of 81c was given. Someone, not Weeber, has written on the letter, "Is credit to be given Mr Barzen 81c?" Weeber replied, "Cr. Barzen Chg. Ex."⁴⁴²

At the end of August, Dan C. Swanden [illegible?], of Firestone in New York, responded to a Weeber request for the repair of a tire.

We note in your letter that you say your customer was only able to secure from 500 to 1,000 miles, and we think he must have advised you wrong on this, as the appearance of the shoe shows upwards of 2,000 miles of service, and is in such a condition that we could not make satisfactory repair.

We are willing to make an exception in this case and send you a new shoe in adjustment for \$10.00 net.

We think your customer should have no reason to complain at this price, and upon receipt of instructions from you we shall be pleased to make prompt delivery.⁴⁴³

Weeber wrote in pencil on the letter, "Desk Show to Mr. Bishop." The letter is also marked, "Write

⁴⁴¹W. P. Beuren [illegible?] for the Firestone Tire & Rubber Company to C. F. Weeber Mfg. Co., July 6, 1909.

⁴⁴²"Barzen" may have been Phillip J. Barzen, an Albany saloon keeper, according to the 1909 city directory.

⁴⁴³Swanden to C. F. Weeber Mfg. Co., August 31, 1909.

that our customer has stated the truth & does not want anything done" as well as "Ans. 9/4 Copy." Firestone wrote again in an unsigned, September 7 letter to acknowledge that their proposal, "... is not satisfactory to your customer. If you can make an adjustment with your customer, which will be satisfactory to him, by getting \$6.75 for a new case, kindly advise, and we shall ship a new one on this basis. We want to get your customer lined up for you, and we are willing to make this concession not because we feel he is entitled to this price, but in order to help you retain his business." The Firestone letter is marked in pencil, "Mr. Bishops Case," "who's case is this," "Wrote 9/9/ copy" and "Desk."⁴⁴⁴

The Fisk Rubber Company of Chicopee Falls, Massachusetts was a major supplier of rubber goods. A number of Fisk letters to Christian Weeber or the Weeber Manufacturing Works as well as two bills survive from the 1907-1910 period in the Weeber collection at the New York State Museum. In October 1907, Weeber purchased six outside sleeves for tires and cement and French chalk for \$7.85 less 5%. Shipment was from the New York branch of the Fisk Company but payment was made to the "home office" on October 21.

On February 8, 1908, the New York branch of the Fisk Company wrote in response to a request for a "moulded 3¼ x 28 casing." Unfortunately for Weeber and his customer, that tire had been discontinued. Rather than purchase a substitute style at a dealer price of \$24.88, Weeber directed on the Fisk letter that his employee should, "Write that owner had decided to have old retreaded." The following April, Weeber shipped a similar tire although in "3½ x 30" size for possible repair. "Upon examination, we find it to be a tire manufactured in 1904, and its condition is such we could not repair; and we regret to state we cannot offer your customer any adjustment on this casing, owing to its extreme age. You, no doubt, know the natural deterioration

⁴⁴⁴The Albany city directory for 1909 lists twenty people named Bishop. For another tire judged previously repaired "by an outside party" and worn out, Firestone, September 11, 1909, advised that no adjustment was in order and that a new tire would cost "\$23.00 net." That letter is marked, "Show to Mr. Edile [illegible?]", "Send back" and "Wrote to return 9/22." The city directory lists L. S. Edler & Company, coal shippers, as well as Charles and John E. Edick, both waiters.

of rubber would ruin a casing in this length of time, if it had not been used at all."⁴⁴⁵

P. H. Wilson of the Fisk Company advised Weeber's "customer to get what service he can from it, as it would not be advisable to repair." Weeber marked the Fisk letter, "Order returned." Among the other surviving Fisk letters is one from the New York branch in July 1910, responding to a Weeber request to return two tires "in exchange for other goods. Providing these tires are in first-class and saleable condition, we shall be willing to have you return them to us, and we will credit you at the price paid for same. Any goods taken in exchange, however, we will of course bill at present prices."⁴⁴⁶

A photograph of the C. F. Weeber Manufacturing Works showroom interior in 1909 or 1910 shows two permanent signs advertising "Fisk Tires Any Rim." Another sign fixed to the wall between the showroom and workshop in the photo is for G & J tires, the product of the G & J Tire Company of Indianapolis, Indiana. Apparently, Weeber was a G & J dealer at the same time as he sold Fisk tires.

Twelve invoices from 1909 document Weeber generally traded with the G & J New York branch. Tires and tubes were the chief business but repairs and the purchase of tire cement and talcum powder also are documented. Shipping was by the American Express Company. On many of the bills is pasted a slip of paper marked, "This invoice is subject to a further trade discount of 5%." The invoices are marked with both Weeber and G & J order numbers. An exception is the last invoice that documents "Your Order Wire" for a 36" x 5" clincher case and two tubes for \$78.10. This sum was discounted at 5% twice, the bill marked in pencil for one discount, "Brown allows."

In early August 1909, Weeber wrote to the G & J New York branch about a "34 x 4 Clincher off a Ford six-cylinder car, which was shipped into us in damaged condition, and we note what you say about this case having been used only about one month." G. & J manager W. K. Philp [illegible?] observed in a letter dated August 6, however, that the tire "had either [been] given a very good mileage up the present time or had been consid-

erably abused. . . until every ply of fabric has been worn through." While the "original cover may not have been quite what it should," replacement apparently would not have been a "fair proposition." Consequently, Philp offered to replace the case with a new one for \$25. His letter is marked in pencil, "Look at Dealer price 34.50 trade 39.50 customer write. . . wrote 8/11." A. E. Vinton, G & J "local manager," replied on August 18,

In view of the facts as outlined in your letter we have decided to reduce our former proposal of \$25.00 for replacement on this casing and will make the charge \$20.00.

We are forwarding you a new casing in replacement on this basis which we trust will be entirely satisfactory to all parties concerned.

Five invoices from the period May through September 1909 document Weeber's purchases from the Diamond Rubber Company of New York, a subsidiary of an Akron, Ohio firm. All shipments were by American Express from New York. The four bills for the sale of tires are marked in pencil figuring a 5% discount, again one assumes from dealer prices. The fifth invoice is for the \$4.40 repair of a tire. Two bills have slips pasted to them noting that "DIAMOND TIRES, Casing and Tubes are worth all and more than they sell for. We reserve the right to withdraw prices from any dealer who sells to consumers below our schedule price."

Correspondence from the Diamond Rubber Company dates from January 1908 (with reference to sales in late 1907) and ends in September 1909. The last date coincides with a 10% price increase for both dealer and end customer. Whether this increase determined an end to Weeber dealing with the Diamond Rubber Company is unknown here. The tenor of the earliest letters indeed suggests an unpleasant affair regarding charges; a situation which might well have given cause to end the purchase of tires at that point.

The first Diamond letter accompanied a check for \$28.95 to reimburse Weeber for a November 1907 C.O.D. shipment. The letter also mentions a credit to Weeber's account of \$24.40. Apparently this was a charge, later subject to an adjustment to \$18.55. A January 29, 1908, letter from the Akron credit department requested payment "so we can

⁴⁴⁵P. H. Wilson for the Fisk Rubber Company to C. F. Weeber Mfg. Co., April 11, 1908.

⁴⁴⁶T. H. Wilkins for the Fisk Rubber Company to C. F. Weeber Mfg. Works, July 29, 1910.

close out the November account."⁴⁴⁷ Next, after Weeber requested advice from Diamond's New York office, J. Jordan wrote the following:

We cannot quite understand the situation, as the amount which now stands against you is quite in accordance with our regular trade schedule. The event leading up to the delay and trouble which were caused by you have been fully explained and, while we very much regret the apparent negligence on our part in connection with this shipment, we do not think that you will find further reason for withholding payment of the amount due.

Enclosing documentation including, "the papers which Mr. Davidson brought in with him from his last visit to you," Jordan wrote again after receipt of another Weeber letter:

To be perfectly frank, we do not understand what further you wish us to do with regard to our charge but, if there is anything that we have overlooked and that can possibly be done to wipe out the trouble caused you, we shall be very glad to hear from you.

The last Jordan letter in this matter responded to another Weeber note. As indicated above, the response to this last letter was satisfactory enough to both sides that trade continued.

In reply to you favor of the 4th inst., we had no previous idea that you were looking for an agreement that would reduce the amount of our charge, or we would have told you before that any such proposition would be entirely out of the question.

We are very sorry to state that no change can be made in the account and we, therefore must ask that you make settlement in accordance with the enclosed statement.⁴⁴⁸

In fact, the Weeber relationship with the Diamond Rubber Company's New York branch remained cordial and helpful to Weeber into September 1909. In late August, the Weeber Works shipped a damaged tire that the Diamond people discovered to be "jabbed through in one place, and the tread is cut, loose and worn." Nevertheless, the tire could be repaired "by inserting a new section and applying new tread, and we will be pleased to do the work for you, merely charging for the

⁴⁴⁷H. E. Riker to C. F. Weeber Mfg. Wks., January 29, 1908.

⁴⁴⁸J. Jordan for the Diamond Rubber Company to C. F. Weeber Mfg. Works, February 3, 1908; February 4, 1908; February 8, 1908.

sectional repair, which would be approximately. . . \$4.00."⁴⁴⁹ The letter is marked in pencil, "Write to Repair same & return as soon as possible."

A few days later, Weeber shipped an inner tube that the Diamond staff found "slightly cut on the base." But, "If it will be the means of adjusting the matter to your customer's entire satisfaction, we will be glad to repair this tube, putting it in first class condition, without expense to you."⁴⁵⁰ Weeber marked the letter "Wrote 9/15" and the Diamond Company replied on September 17 reporting that the tube already was in the "repair shop to be put in good condition without charge. As soon as repairs are complete, it will be returned to you."⁴⁵¹

The latest Diamond price lists in the Weeber collection at the New York State Museum date from 1915 with both a "Users Net Prices" folder and a "Trade Prices" folder noting prices in effect on February 1. A smooth tread 30" x 3" size, one of the more common types in use, listed for \$8.50 but cost the dealer only \$7.25 less five percent for cash.

On three occasions in the spring and summer of 1909, the Empire Tire Company of Trenton, New Jersey, sold the Weeber firm "red [inner] tubes shipped "U S Coll." [United States collect]. The Empire Company also credited the Weeber account with \$4.15 for a 32" x 3" tube, apparently defective item. Weeber's cover letter, however, had indicated that the tube in questions was a 30" x 3½" size. Empire shipped the latter style, charging Weeber the difference.⁴⁵² He marked the Empire letter, "Is this OK CFW," suggesting that someone needed to check the requirement.

After an inquiry in April 1908 at the Hartford [Connecticut] Rubber Works Company about a price on a Dunlop tire for a customer, the Weeber Manufacturing Works purchased tires, tubes and

⁴⁴⁹William L. Hampton to C. F. Weeber Mfg. Works, September 2, 1909. The invoice for the tire repair is for \$4.40. Dated September 14, 1909, it was marked paid on October 16, 1909.

⁴⁵⁰William L. Hampton to C. F. Weeber Mfg. Works, September 14, 1909.

⁴⁵¹William L. Hampton to C. F. Weeber Mfg. Co. [sic], September 17, 1909.

⁴⁵²Ray S. Paddock for the Empire Tire Company to C. F. Weeber Mfg. Works, June 2, 1909.

shoe liners from the Hartford Company in April, September and October 1909.⁴⁵³

From the Excelsior Tire Company at 1777 Broadway in New York, "Mr. Weeber" bought four Hartford cases (two each of 36" x 5" and 36" x 4") for \$110 total with the invoice marked in ink by hand, "Guaranteed 1st Class stock & regular mileage." In 1909, he also purchased four tires (\$10.38 each) and four tubes (\$2.58 each) as seconds from the Wilson Trading Company in New York for \$51.84 less \$2.59. That invoice was stamped "not guaranteed."⁴⁵⁴ A letter from May 1909 indicates an earlier order to Wilson "given our Mr. Crook on the 11th inst." that was shipped less seconds of two Diamond tubes "we are all out of, and at the present time we cannot say when we will have any more to offer."⁴⁵⁵ In August 1909, the Weeber Works purchased a "M. & W. [Morgan and Wright] Second 36 x 5 Bailey Tread" tire for \$36.92 subject to 2% discount if paid within ten days⁴⁵⁶ from the New York Sporting Goods Company, a supplier of various automobile parts and accessories.

On August 4, 1909, the Albany Hardware and Iron Company sold the Weeber Company two Continental casings, two Capitol tubes, tire lugs and tire chains for \$126.52 including discounts. Apparently, Weeber questioned the price charged for Capitol inner tubes. Albany Hardware replied, "that since the advance in prices on July 15th, the best we can do on Capitol Tubes is \$10.55 [in 36" x 5" size] less 5% with an additional 5% for cash. Our bill is therefore, correct. This makes it 5% cheaper than either the Goodrich or Diamond or any of the others."⁴⁵⁷ Actually the invoice price on the Capitol tubes had been \$10.60 so that Weeber was now charged 5c less. Payment followed on October 22.

In April 1908, the Weeber works ordered a "set of tires" from the Ajax-Grieb Rubber Company in

New York.⁴⁵⁸ The Crescent Tire Company, at 1947 Broadway in New York, was a source for a \$22.50 tire in 1909, which was shipped cash on delivery. In January 1911, the Weeber Works exchanged two "30 x 3 Imperial Shoes" with the Automobile Surplus Stock Syndicate at 160 W. 56th Street in New York.⁴⁵⁹

In September 1909, both the Goodyear Tire & Rubber Company in Akron and the Continental Caoutchouc Company in New York City sent notices to the Weeber Manufacturing Works of price increases due to the rising cost of crude rubber. Goodyear noted that on September 25, 1909, the price was "in the neighborhood of \$2.10 per lb.—by far the highest price ever known."⁴⁶⁰ On September 28, Continental said their price increase was ten percent on tires and tubes.

The covers of two booklets describing Acme Red Letter tires are imprinted with the name and address of the C. F. Weeber Manufacturing Works, giving evidence that on February 1, 1915, when the listed prices went into effect, the Weeber firm was an Acme dealer. The Acme Rubber Manufacturing Company of Trenton, New Jersey, claimed in the booklets that their tires were superior partly because their employees were paid on a day wage and premium plan with close supervision of each man's work, thus insuring against the carelessness and imperfections of hurried piecework common in many of the large factories.⁴⁶¹ Pencil notations and calculations mark each booklet. Calculations on both show a ten percent discount from an initial price.

Other tire price lists from the 1910s in the Weeber collection include those from the United States Rubber Company of New York (February 1, 1915 net price list for "Nobby Tread Tires");⁴⁶² Rutherford Rubber Company of Rutherford, New Jersey (July 1915 consumer prices in a catalogue⁴⁶³ stamped with the Albany Branch address of 177

⁴⁵³The April 13, 1908, Hartford letter to the C. F. Weeber Mfg. Works was signed by E. S. Roe. Weeber marked the letter, "Hold until you hear from Hubbard," perhaps referring to a customer as well as "200 [\$2.00] extra."

⁴⁵⁴The Wilson invoice is dated September 29, 1909. The Excelsior invoice is dated only "June 23."

⁴⁵⁵Wilson Trading Company (unsigned) to C. F. Weeber Mfg. Wks., May 14, 1909.

⁴⁵⁶The invoice, dated August 28, 1909, notes the tire was shipped on August 25.

⁴⁵⁷W. J. B. for Albany Hardware and Iron Company, August 14, 1909.

⁴⁵⁸M. J. Jacobs for the Ajax-Grieb Rubber Company to the C. F. Weeber Mfg. Wks., April 2, 1908. In the letter Jacobs notes that the order failed to specify a tire size.

⁴⁵⁹The invoice dated January 17, 1911, was marked by Weeber "From & for Downing" and "Good Rec." The Weeber address is typed "47 Bradford St."

⁴⁶⁰An undated sheet, perhaps part of a catalogue, lists Goodyear prices for Akron clincher tires and Goodyear single tube and detachable tires. H-1933.6.382.

⁴⁶¹H-1933.6.318 and H-1933.6.324.

⁴⁶²H-1933.6.330.

⁴⁶³H-1933.6.252.



Figure 6.1: Photograph of Cover of Acme Red Letter Tires booklet with Weeber imprint. The C. F. Weeber Manufacturing Works sold tires made by the Acme Rubber Manufacturing Company of Trenton, New Jersey, as documented by this 1915 price list. NYSM Collection, H-1933.6.318.

Central Avenue—across the street from the Weeber Works); Pressman Tire Company of Philadelphia (dealer prices effective January 1, 1917); Mason Tire and Rubber Company of Kent, Ohio (end user prices effective January 4, 1917) with a Hinsdill Electric Company (378 Central Avenue in Albany) imprint; Tough Tread Tire Company of Newark, New Jersey (undated end user list); Schavoit Rubber Company of Stamford, Connecticut (end user price list effective April 2, 1917) on which Christian Weeber noted in pencil, “9/13/17 Less 30%”; McLean Tire & Rubber Company of Cleveland (end user list effective September 17, 1910 for Champion tires); B. F. Goodrich Company (“Car Owner’s List” effective May 8, 1918); and the Swinehart Tire & Rubber Company of Akron, Ohio. The last group consists of a Swinehart brochure explaining the benefits of Swinehart “Cellular Truck Tires,” an end user truck cellular and hard rubber tire price list effective July 1, 1915; and an end user price list effective January 1, 1917, for pneumatic tires. A two page mailing from the National Tire Company of Trenton, New Jersey, has been marked “4/4/17” by Weeber. Giving both net and list prices, the flyer suggests the dealer could “split the difference with your customer and save him 20 per cent and have profit of 33 1-3 per cent on your cost. Do this and you will get most of the Tire and Tube Business in your section.”⁴⁶⁴ A booklet displaying photos of vehicles using McNaull tires probably dates from 1917. The rear cover is stamped with “R. C. Garhartt Corp., 15 Central Ave. Albany, N.Y.”⁴⁶⁵

With tires prone to puncture and other injury resulting in loss of air, motorists of the 1900s sometimes sought alternatives to a pneumatic cushion on their cars. One alternative was a denser elastic substance in the tire. In 1909, the Weeber Works paid the Newmastic Tire Company in New York City for filling four tires with Newmastic material. The price was \$25 each for two 36” x 5” tires and \$21 each for two 36” x 4.” The total, \$92, was discounted 20%, then 10% and then

⁴⁶⁴H-1933.6.392.

⁴⁶⁵H-1933.6.308. The most recent license plate in the photographs shows a “1917” date.

5%, making Weeber's cost \$62.93.⁴⁶⁶ A Newmastic booklet in the Weeber collection at the New York State Museum dates from 1905, as the formerly St. Louis-based company was reorganizing and apparently relocating to 370 Manhattan Avenue in New York.⁴⁶⁷ A handbill in the Weeber collection touts the Pneumo-Wheel, a device using a solid rubber tire with a pneumatic hub.⁴⁶⁸ Whether the Weeber Works purchased any of the wheels, patented in 1906 by C. F. Marohn in Milwaukee, is unknown here.

For repair of tire tubes and for tire maintenance supplies during the first ten months of 1906, Christian Weeber turned to his brother, Emil, at the Weeber Cycle Works. Purchases on 39 different days ran up a total of \$14.02 for repair of auto tubes and sale of tape, "valve insides," a pump, ball bearings and several cans of enamel paint. Repairs to a "green wheel" (bicycle) on April 13, July 13, August 14 (new spokes truing green wheels) and September 11 ("fitting new chain on green wheel"), all suggest Christian, or perhaps Pauline Weeber used a bicycle. Fitting a New Hartford 77 tire on April 24 for \$2.75 likely was on the bicycle.⁴⁶⁹

In November 1907, the C. A. Shaler Company, makers of electric vulcanizers in Waupin, Wisconsin, acknowledged a Weeber order and its particular request. The text of the Shaler letter gives light on Weeber's business conditions at the time and suggests the importance of vulcanization in tire maintenance.

Agreeable to your favor of the 19th we are making immediate shipment of your future order, and altho' strictly contrary to our usual terms, we are invoicing to date As Jan'y 1st.

A regards to advisability of consigning Vulcanizers, we of course cannot decide such a matter for you, but we ourselves would absolutely refuse to consign any goods, as we believe it does not display good faith on the part of the consumer that will demand such terms. Our Guarantee is sufficiently generous to insure and sincere purchaser of our line.

⁴⁶⁶The 5% figure likely indicates a discount for payment within a stipulated number of days. The bill is dated June 14, 1909, and marked paid on June 29. The Weeber Works also purchased 22 lugs at \$.35 each and two inner tubes at \$3.50, making the total paid \$77.63.

⁴⁶⁷H-1933.6.388.

⁴⁶⁸H-1933.6.383.

⁴⁶⁹The bill dated November 1, 1906, for C. F. Weeber is stamped paid, although the date of payment is not recorded.

Thanking you and feeling very sure that if you continue your interest in the Vulcanizers you can certainly turn over a very generous quantity of them, we are...⁴⁷⁰

On June 9, 1909, the Weeber Works ordered Hagstrom patches from Charles J. Downing, "Factory Sales Agent" for automobile supplies in New York City. On July 23, Downing wrote to state that Weeber's order for six 3-inch Hagstrom patches "was forwarded by me with Mr. Blaisdell who will arrive at your City this morning. I hope he leaves them with you and if he overlooks it please write me on receipt, and oblige." Downing wrote again on September 18, 1909, to list three separate \$8 shipments of six patches each (July 22, September 7 and September 18). "These bills are rendered under the name of the Standard Motor Parts Co., which name I use so as to keep my Jobbing business separate from my Mfr's Agency accounts." Downing hoped this reckoning "agrees with your books." In April 1910, Albany Hardware provided blowout patches for cars belonging to Travers, O'Neil and Barrett.⁴⁷¹ In July 1909, Albany Hardware had sold Weeber one dozen rolls of tire tape at \$.30 each.

In May 1909, the Anderson Forge and Machinery Company of Detroit telegraphed the Weeber Manufacturing Works. "Will express thirty by three and one half clincher type wheel today unless advised."⁴⁷²

In December 1907, the C. F. Weeber Manufacturing Works bought one pair of Kant Skids from the Leather Tire Goods Company of Newton Upper Falls, Massachusetts. The author presumes these were detachable treads placed over regular tires. In 28" x 3" size, the devices cost \$9.00 less 25% (\$2.25) plus another 5% (\$.35) as shown in Weeber's pencil notation on the invoice. A Leather Tire letter apologized for slow delivery of the Weeber

⁴⁷⁰Unsigned letter from C. A. Shaler Company to C. F. Weeber Mfg. Works, November 21, 1907. The letterhead notes the Shaler portable vulcanizer, when attached to an electric light socket and used current costing 1/2c per hour, maintained constant heat while mending cuts, punctures and blowouts.

⁴⁷¹The invoice dated April 20, 1910, lists "Travers Blowout Patch #2" and "O'Neil Blowout Patch #4", etc. The author assumes these are the names of car owners rather than blowout patch manufacturers. The invoice is marked in pencil, "order returned."

⁴⁷²Postal Telegraph Commercial Cables telegram, May 15, 1909, 12:15 p.m. The telegram is marked in pencil, "Phoned Sm. [illegible?] 12 30 p.m."

order but noted a “great rush of business this Winter and... the recent fire which destroyed our factory...” Within a few days, Leather Tire hoped to be shipping the same day that orders were received. “Hoping that the goods will not be too late for your customers and wishing you a prosperous new year, we remain.”⁴⁷³



In the winter of 1908, Christian Weeber communicated with the Stepney Spare Wheel Agency, Inc. in New York City about an English emergency wheel system for quick resumption of a journey interrupted by tire damage. A fifth tire mounted on a rim could be bolted quickly to another wheel with a flat tire, thus avoiding the changing of a wheel or the repair of a flat tire on the spot. The Stepney letterhead claimed, “On and Gone In Less Than a Minute.”

Perhaps the Stepney system came to Weeber’s attention via Walter L. Palmer. A Stepney letter addressed to Palmer at 5 Lafayette Street in Albany, in the Weeber collection at the New York State Museum, tells of the advantages of using the Spare Motor Wheel and of the sales successes, e.g., “It is the wheel used on every taxicab in New York City.” Weeber has written on the letter to Palmer, “Wrote for prices 2/20.”⁴⁷⁴ Palmer, a Weeber customer, who in 1906 drove a Maxwell,⁴⁷⁵ was a well-known painter, Walter Launt Palmer (1854-1932), son of the even better known sculptor, Erastus Dow Palmer (1817-1904). In 1908, Walter shared the Lafayette Street address with his mother, May J. Palmer. In 1906 he had provided a testimonial letter for the Weeber shock reliever, claiming that

⁴⁷³A. P. Marshall for the Leather Tire Goods Company to C. F. Weeber Mfg. Works, December 31, 1907. The Weeber collection at the State Museum also includes a handbill dated May 5, 1910, from the 20th Century Tire Protector Company in Midlothian, Texas, for a leather tire cover suitable for clincher rims. The cover letter offered Weeber 25% off list prices until “we have placed an agent in your territory.”

⁴⁷⁴The Stepney letter to Palmer is dated February 17, 1909. It was signed by W. Liesberger.

⁴⁷⁵*The Argus*, September 23, 1906. On September 9, the paper reported that during the summer, Palmer had been “making a tour of the resorts on the New England coast” presumably with his auto. With the twelve-horsepower Maxwell he had been “in town Wednesday. He came up from Selkirk, where he has a country home.”

after two months they had “added greatly to the comfort and pleasure of riding.”⁴⁷⁶

A Stepney letter dated February 25, 1908, obviously in response to a communication from Weeber, offered to send a wheel for sixty days with freight paid both ways if Weeber was not satisfied with it. He noted at the bottom of the letter “ordered 3/2.”

The next Stepney communication, on March 9, 1908, reports shipment of a 32” x 3½” wheel, although it appears that Weeber asked for a 32” x 4.” “We will ship you at the earliest possible moment the other wheel ordered and you need not hurry in returning this wheel as same can be used for demonstrating purposes and returned at a future date.” If Weeber were to “forward us sufficient orders” in the following thirty days, he “very likely” would be offered “exclusive rights to Albany and nearby towns.”

On March 24, the Stepney firm wrote to acknowledge a Weeber letter from the previous day “and return herewith invoice marked ‘thirty days, twenty percent.’” Stepney “regret[ed] that you are returning the wheel, 32 x 3½, as there is no doubt but you would have had a call for same sometime in the near future...”

On May 18, 1909, “L.E. Roy” wrote on behalf of the American Stepney Spare Wheel Company to say that the Weeber order from the previous day for a wheel to fit both the front and rear of a Thomas Flyer, sizes 36” x 4” and 36” x 5” respectively, could not be filled since no Combination Wheel could fit ordinary wheels with more than one-half inch size difference. American Stepney took “the liberty of sending... via American Express a... size 36 x 5 to fit on the rear wheels in view of the fact that accidents are more liable to happen to the rear wheels than to the front.” The date of the order suggests that Weeber intended to equip one of the Thomas Flyer vehicles being prepared for the Interurban Auto-Bus operation described later in this work.

In the summer of 1909, Stepney billed for three wheels, two combination 30” x 3½” x 3” clinchers at \$25 each on June 11, 1909; and one 32” x 4” reg-

⁴⁷⁶The testimonial letter, dated November 19, 1906, was one of several Weeber and shock absorber inventor Fletcher W. Battershall had copied in stereotype format for advertising use.

ular clincher at \$22 on June 25, 1909, all subject to a 20% discount.⁴⁷⁷

Perhaps Christian Weeber attempted to become a distributor of the emergency wheels himself. Or perhaps he merely wished to dispose of unsold wheels. In either case, a letter from the Anderson Forge and Machine Company in Detroit responded to a Weeber solicitation. "Replying to your inquiry of the 17th inst., will state that existing conditions are such that we have recently decided not to book any new orders for Emergency Wheels. Regretting that we cannot be of service to you in instant, we remain."⁴⁷⁸



In July 1909, Indicator Sales Company, Inc., at 1773 Broadway in New York, shipped via American Express 50 valve caps, 25 valve "insides" and 6 "Pressuretell Valves" (one dollar each) for a total of \$7.85. The last were indicating tire valves with a built-in pressure gauge. An August 1909 Indicator Sales letter suggested that Pressuretell prices and all other Schrader valves and parts could be had at prices "much lower than you have heretofore been paying." For example, valve caps were \$17.50 per thousand and Pressuretell valves 76c each.⁴⁷⁹ The American Vulcanizing Works, at 211 Hudson Avenue in Albany, provided repair work for tires and tubes. From late winter into the summer of 1909, American Vulcanizing repaired a tube and case for a car belonging to "P. Dederick" for \$3.55 less 25% and four other tires and three tubes. Tire repairs cost from \$1 to \$3.50. Fixing tubes was \$.55 to \$1.00 with all charges subject to a 25% discount. Invoices from the summer of 1910 indicate further repair work, such as "blowout repaired retreading" of a Diamond case for \$12 subject, still to a 25% discount.

Tire Pumps

In October 1906, the Weeber Works were billed by the Judd and Leland Manufacturing Company

⁴⁷⁷ A bill from June 11, 1909, for two 30" x 3½" x 3" "Comb. Reg. Cl." (combination regular clincher) wheels at \$25 each may be the initial invoice for the 30 x 3½ x 3 inch wheels.

⁴⁷⁸ F. Archer Hinchman, secretary and treasurer of the Anderson firm, to the C. F. Weeber Mfg. Works, August 20, 1909. Weeber marked the message with a pencil oval apparently indicating that he had read it with no further action required.

⁴⁷⁹ L. E. Ray for Indicator Sales Company to Eeber [sic] Mfg. Works, August 27, 1909.

of Clifton Springs for a "sample Eureka Triplex" pump for \$4.50, a bill paid the following December.⁴⁸⁰ In the winter of 1908, Christian Weeber wrote to Judd & Leland about a problem with a "Eureka Triplex pump," presumably a different unit. He was advised to return it "by first express and we will put it in shape at no expense to you." Judd & Leland further thanked Weeber "for calling our attention to the defect" and Weeber was advised in response to his query that the "best single cylinder auto pump that we make" cost \$.75 with a brass cylinder and \$.65 in a steel version.⁴⁸¹ Weeber noted on the letter, "Ans. 3/30 Pump sent 3/30."

Tire Holders and Covers

Accessory tire covers were sold to the Weeber Manufacturing Works by the New York Sporting Goods Company. A 34" x 4" buttoned cover costing \$1.65 was "Shipped With Other Goods" in August 1909.

Another supplier of tire covers was the Nathan Novelty Manufacturing Company, incorporated as the Nathan Anklet Support Company on Reade Street in Manhattan. A June 1909 letter advised the C. F. Weber [sic] Manufacturing Works that covers made of a "new enameled material," less likely to crack than other stuff, were available with a reduced cost due to Nathan's "making large quantities, which we are now doing." In lots of one dozen, the covers were \$16.50 per dozen without bags and \$18 with bags. In lots of twelve dozen, the prices were \$12.75 and \$14.25. Edwin Nathan noted, "We will be pleased to receive orders for twelve dozen quantities, shipments of same may be divided into two or three parts between now and September 15th."⁴⁸² Whether Weeber ordered any Nathan tire covers is unknown here but as will be seen below, Weeber did buy top covers from the New York supplier.

⁴⁸⁰ The Judd and Leland billhead notes manufacture of Cyclone and Tornado bicycle and spray pumps, tin ware, leather valves, plungers and packings.

⁴⁸¹ Z. H. Haney, Judd & Leland secretary, to C. F. Weaver [sic] Mfg. Co., March 25, 1908.

⁴⁸² Edwin B. Nathan to C. F. Weeber Mfg. Works, June 4, 1909.

FACTORIES STANNEILLS, U.S.A. BERLIN, GERMANY.
LLANNELLY, ENGLAND, PARIS, FRANCE.

TELEPHONES 4580 COLUMBUS.
4-581

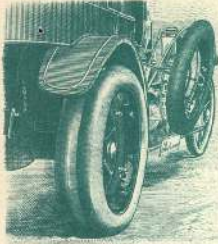

REAR VIEW SHOWING STEPNEY IN USE

American Stepney Spare Wheel Co.

1773 Broadway,
New York.

INCORPORATED.

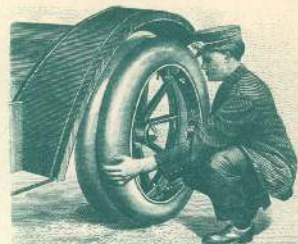

STEPNEY BEING ATTACHED

CHIEF OFFICE | CHELTENHAM
| GLOUCESTER, ENGLAND.

EACH WHEEL REGISTERED
AND FULLY GUARANTEED.

August 9, 1909.

REFERENCES

Andrew Carnegie
John Jacob Astor
Harry Payne Whitney
C. K. G. Billings
Thomas Edison, Orange, N. J.
Hon. Truman H. Newbury, Sec'y Navy
Senator Foraker, Cincinnati, Ohio
F. F. Proctor (Keith & Proctor)
J. D. Adams (Adams Chewing Gum Co.)
Percy Wrigley (Wrigley Spearmint Co.)
Percy G. Williams
William Morris
Martin Beck
Bryce Allen (Allen Steamship Line)
Lichtenstein Millinery Co.
Knabe Piano Co.
John Huyler (Huyler's Candy)
Clarkson Cowl (James A. Hearn & Co.)
A. J. Cammeyer
City Dept. of Finance
John W. Gates
John Underwood, (Underwood Typewriter)
Franklin Simon Co.
A. A. Cowles
W. H. Cooper (Siegel Cooper Co.)
Temple Bowdoin
N. Y. Taxicab Co.
N. Y. Transportation Co.
Hexter Taximeter Cab Co.
Wm. H. Seach Co.
Union Taxicab Co.
Quaker City Cab Co., Philadelphia, Pa.
Taximeter Cab Co., Boston, Mass.
Atlanta Taxicab Co., Atlanta, Ga.
Cherry Auto Cab Co., New York
Central Park Taxicab Co., New York
Parkway Taxicab Co., New York
Atlas Motor Car Co., New York
Sultan Motor Car Co., Springfield, Mass.
Packard Motor Car Co., Detroit, Mich.
White Steamer Co., New York
John T. Brush, N. Y. Base Ball Club
J. M. Schoonmaker, Vice-Pres.
N. Y. L. E. & W. R. R.
Maxwell-Briscoe Co., Tarrytown, N. Y.
Lossier Motor Co., New York
Moulton Stables, New York
New York Cab Co., New York
Frawley's Stables, New York
Louisville Taxicab Co., Louisville, Ky.
Syracuse Taxicab Co., Syracuse, N. Y.
Zimbrich Taxicab Co., Rochester, N. Y.

The C. F. Weeber Mfg. Works,
Albany, N. Y.

Gentlemen:-

Replying to your favor of August 4th,
beg to state that you are correct in your
assertion in regard to sending us a check
for \$56.00 representing the gross bill of
June 13th.

We would have discovered this
mistake and notified you to that effect had
our bookkeeper been up to date in his work,
as we have been systemizing our books for
the past month, and we naturally fell
behind with the current work.

When your check was received, an
entry had been made of same, and if it were
posted immediately, we would have discovered
the mistake at the same time.

We therefore beg to submit, as per
your request a statement of your account to
date, deducting 20% of the total and crediting
you with your check of July 31st for \$56.00.

We trust that this explanation is
entirely satisfactory to you.

Thanking you for past favors, and
anticipating your further commands, we remain

Yours very truly,

AMERICAN STEPNEY SPARE WHEEL CO.

By *J. Roy*

Figure 6.2: The Stepney Spare Wheel Company letterhead. NYSM Collection, H-2000.39.NN.

Jacks and Tire Chains

Frequent tire changes called for jacks to lift wheels from the ground. The Oliver Manufacturing Company of Chicago, whose billhead claimed Oliver was the "Largest Manufactory of Jacks in the United States," sold the Weeber Manufacturing Works twenty-five jacks in May 1909. The cost was \$2.50 each less 60%. The bill was paid in July 1909.

Chains to improve traction in mud and snow were sold and used frequently. As will be seen below, Christian Weeber secured a patent for tire chains. In February 1909, however, his company purchased two sets of Weed brand chains at \$5.25 each from the Post & Lester Company. In addition, the order contained two gas lamps, a half-pound of repair patches and a half dozen Michelin tire irons, all shipped via Adams Express. The Weeber operation purchased additional items from Post & Lester in March and April 1909, including tire covers, screw drivers, pliers, valve tools and lamp burners.⁴⁸³

In 1910, Weeber "wrote postel [sic] for price" after receiving an advertisement from the Standard Traction Tread Company, a Boston, Massachusetts firm selling chain on a reel. The dealer would cut the requisite chain from the reel needed for a customer's tires, obviating the need to stock or order many different chain sets to fit a variety of sizes. Standard Traction Tread responded to Weeber's postcard with a letter outlining discounts for a first order as well as subsequent orders. "We are ready to ship Standard Traction Treads now, in any quantities, either in reels or bagged in pairs, if so required, though cost per pair to you in reels is much less."⁴⁸⁴ Whether the Weeber Works ordered any Standard chain is unknown here.

⁴⁸³The Weeber collection at the New York State Museum includes a 1907 Post & Lester catalogue. The inside cover is printed, "We Sell the Trade Only." The Post & Lester Company, *Motor Car Supplies 1907* (Hartford, Ct.), H-1933.6.193. Also in 1909, Weeber received two letters (July 20 and December 28) from the Weed Chain Tire Grip Company of New York alerting him about patent infringements on the Parson's Non-Skid patent, "under which we are the lone Licensees."

⁴⁸⁴J. L. Mulholland, secretary, to Messrs. C. F. Weeber Mfg. Works, March 23, 1910. The first Standard communication from March 18, 1910, was signed by M. A. Kennedy, apparently Standard's president, since Mulholland had written, "Answering your inquiry, we take pleasure in enclosing you [sic] booklet covering Mr. Kennedy's experience with Chain Treads. You will find it thoughtfully written by a conservative Dealer."

A September 1914 price list for Weed chains for solid (truck) tires in the Weeber holdings at the New York State Museum points to Weeber's involvement with truck sales and repairs. His business dealings with individual truck manufacturers are delineated elsewhere in this book.

General Supplies

The Motor Car Equipment Company claimed to carry "Automobile Supplies of Every Description." The Weeber Manufacturing Works, in fact, purchased a variety of material from Motor Car. Surviving bills from 1909 include charges for robe rails, copper tubing, clocks, pliers, rubber gas tubing, lamps, horns, tire cover, funnels, cotter pins, lamp burners, tire irons, muffler cut outs, waste cans, priming cups, trunk racks, oil guns, gas can and wrenches. Charges totaled \$16.41 on five bills dating from April 5, 1909 through August 26, 1909.⁴⁸⁵

Another, more local supplier of metal parts was the Cox Brass Manufacturing Company. In 1909, Cox provided tire holders, lamp brackets, brass foot pedals and a foot rest, all discounted 33⅓% from the retail prices.⁴⁸⁶ The Albany Hardware and Iron Company was a source of a variety of automobile supplies for the C. F. Weeber Manufacturing Works. In the spring of 1910, for example, Weeber purchased six sparkplugs, three jacks, a trunk rack, a case of carbide, a Nightingale exhaust whistle, a Solar acetylene generator (discounted 25%), eight sets of tire chains (25%) and five lamp covers (50%) for a total cost of \$75.28 including discounts.

Electrical Parts and Supplies

The Brooke Automobile Supply Company, at 197 Fulton Street in Manhattan, was a jobber and manufacturer providing electrical parts to the Weeber Manufacturing Company [sic]. In March 1907, the Brooke Company billed for 500 battery connections, 77.5 feet of wire, "cox patches" and a "Sterling animeter." The total bill was \$18.91 for the goods shipped by express.

⁴⁸⁵An August 7, 1909, invoice was for two eight-gallon copper funnels at \$.75 each. Excluded from the list above are backordered Prestolite tanks, mentioned earlier in the text, and folding chairs.

⁴⁸⁶Another invoice, from June 3, 1909, charges \$.70 for two brass hoops.

Herz & Company in New York shipped terminals in early 1908. Mr. [P.D.] Seaborn, a commercial traveler for the American Ever Ready Company in New York, visited the Weeber Works in May 1910 and quoted Bull Dog battery connectors at four cents each (as well as an ammeter at \$1.15). The Monroe Electrical Manufacturing Company in Monroe, Michigan, quoted prices of \$6 to \$12 per thousand connectors depending on type and quantity with the possibility of additional discounts. Whether Weeber responded to either of these offers is unknown here.

Batteries, of course, were important in the automobile trade. In the early years, non-rechargeable dry cells were used both for ignition and lighting. In September 1909, Weeber ordered a barrel of No. 6 Columbia dry cells from the National Carbon Company. With so many cells on order, it was obvious they were intended for resale and National Carbon included "one of our large window advertising signs" in the shipment.⁴⁸⁷ A year earlier, the Stackpole Battery Company of St. Marys, Pennsylvania, had written to "confirm the 14½¢ factory price on contract for our Autocrat Cell made by our Mr. Stover."⁴⁸⁸ In June 1909, J. H. Bunnell & Company of New York wrote to "regret that you have not been ordering as many of our 'JOVE' Dry Cells as it seems to us this season of the year would warrant."⁴⁸⁹ Perhaps the letter had its intended effect, for within a month the Weeber Works purchased 125 "#6 square Jove" batteries at \$.16 each shipped via the "Peoples Boat" from New York.⁴⁹⁰

The Weeber Works, Bunnell's observation notwithstanding, obviously purchased large numbers of dry cell batteries. Bills from the National Carbon Company in Cleveland document the purchase of 125 2½" x 6" size batteries on July 9,

⁴⁸⁷N. C. Cotabish, sales manager, to C. F. Weeber Mfg. Works, September 29, 1909. The Weeber collection at the New York State Museum includes a third edition of *Kinks*, a National Carbon booklet with miscellaneous information intended for the use of automobilists. Published apparently in early 1905, the booklet features information about National Carbon dry cell batteries for ignition use. H-1933.6.276.

⁴⁸⁸H. C. Stackpole, treasurer, to C. F. Weeber Mfg. Co., April 13, 1908.

⁴⁸⁹June 4, 1909. Weeber marked the letter, "Write 6/10 Copy."

⁴⁹⁰The bill also notes the replacement of twelve #6 batteries at no charge; the return of twelve Delta Mic spark plugs; and the shipment of 100 connectors at a cost of \$1.20. "Square," incidentally, refers to the shape of the battery, rectangular rather than the usual cylindrical dry cell cylinder.

1906, for \$20.88; 125 on September 5, 1906; 125 on September 22, 1906; 125 on March 23, 1907; 250 on May 3, 1907 for \$40.50; 375 on July 15, 1907 for \$60.75; 250 on August 30, 1907 for \$40.38; 250 on October 12, 1907; 125 on May 14, 1909 for \$19.38; and 125 on July 13, 1909.⁴⁹¹ In all, 1,875 dry cell batteries were purchased from this one supplier. The Central Electric Manufacturing Company of Rock Island, Illinois, makers of Black Hawk dry cells, also shipped the same size battery. On October 19, 1906, 125 batteries at \$.135 each cost \$16.88; on December 14, 1906, 250 batteries cost \$33.75; and on April 4, 1907, 125 batteries cost \$16.88 plus \$.40 for packing. The American Electrical Novelty and Manufacturing Company was another supplier, shipping via the Peoples [steamboat] Line 125 batteries on April 1, 1909 for \$21.25; two on July 8, 1909 for \$.30 plus \$.06 postage; and 125 on July 31, 1909.⁴⁹²

Christian Weeber's activities in the Albany Storage Battery Company in the 1910s and 1920s are described in a later section of this book. Storage batteries also were in use in the 1908 period. Correspondence regarding storage batteries survives in the Weeber collection at the State Museum from that time. In 1907, while supplying another product, the General Accumulator & Battery Company of Milwaukee sent Weeber sales materials for the Radium storage battery that featured, for an extra cost, a charge indicator attached to each cell letting the observer know at a glance the condition of the battery.⁴⁹³ Other advertising material for storage batteries came from the Electric Storage Battery Company of Philadelphia, makers of the Exide battery, and the Pumpelly Battery Company of Indianapolis. In 1908, the Robertson Electric Company of Buffalo wrote as a follow up to a visit of "our Mr. Rasmussen, who called upon you a day or two ago" regarding the Gould Storage Battery as well as the Pfanstiehl Caterpillar Flame Spark Coil.⁴⁹⁴ A "Catalogue H, '09" in the Weeber collec-

⁴⁹¹Shipping except for the first purchase was "Via Red Line Prepaid." The first shipment was "via 'LSMA—N.Y.C. Prepaid.'" A credit for \$4.05 was allowed on the May 3 invoice "account loose zinc connections."

⁴⁹²The April 1 invoice also included sixty Bull Dog connectors (\$2.10 for all) and six "V. light" (\$4.50 for all). The July 31 bill also charged \$2.43 for three trouble lights.

⁴⁹³William J. Schubert for the General Accumulator & Battery Company to C. F. Weeber Mfg. Works, August 21, 1907.

⁴⁹⁴A.P.H. Saul, sales manager, to C. F. Weeber Mfg. Works, May 1, 1908.

tion at the New York State Museum describes the "Alvern 6-60" ignition battery, the product of the Alvern Battery Company of Evansville, Indiana.⁴⁹⁵

A generator for maintaining the charge of storage batteries was available from the Motsinger Device Manufacturing Company of Pendleton, Indiana. Claiming eight years of production with 30,000 of the "only time-tried automatic dynamo[s] for gas engine ignition" in use, the Auto-Sparker was a "battery charger for all reliable storage batteries, and on account of its uniform speed at different speeds of the engine it is the best."⁴⁹⁶ Weeber replied in December 1907, eliciting a second Motsinger letter. W. G. Silver, Motsinger's secretary, informed the Weeber firm that a quotation of 50% off list price that Weeber had mentioned was an error. The list was \$15, with a "special price of \$13.50 if three or more machines are ordered." The Motsinger note concluded by acknowledging "your willingness to give the machine a trial but better information about this quotation will certainly be appreciated by us."⁴⁹⁷

In early 1908 a Weeber battery customer, Edward D. Mix, wrote to Christian Weeber that the battery in the Mix car was charged several times in March but that was, Mix thought, defective because of a "short circuit or some such like procedure." Mix concluded by writing he was "laying the facts before you for such action on your part as I am entitled to."⁴⁹⁸ Weeber marked the letter "Ans. 4/29" but did not indicate what message he sent.

Another problem battery was a Hobo, the product of the Hoosier Storage Battery Company in

Evansville, Indiana. On May 14, 1909, the Hoosier firm billed the Weeber Works \$27.00 for six HOB0 ignition batteries. On June 29, 1909, Vern W. Jones, Hoosier manager, advised Weeber regarding a problem battery. "Empty the acid all out of this battery, pack it carefully in a box and return to us by freight and we will undertake to put it in good condition again, free of cost, which we trust will be satisfactory to you." Weeber marked on the letter "Show to Henry [illegible?]", Henry, as shown above, was a Weeber employee.

Apparently Weeber liked the Hobo batteries. In July 1909, Jones wrote to acknowledge a telegram of the same day ordering two Hobos by express and four by freight. While prices had advanced fifty cents each a few days before, Weeber was not charged for his order but future shipments would be.⁴⁹⁹ Hobos, however, were inexpensive batteries. Even with the increased prices, they sold for \$5.50 each in lots of one to eleven in a single shipment. An order of 24 or more batteries cost \$4.50 each.⁵⁰⁰

The Albany Electric Illuminating Company provided battery service for Weeber. From March 31 through May 29, 1909, twenty-six batteries were charged and one repaired, at a cost of \$15.75. The two bills sent to Weeber list a surname with each battery. One assumes the names are those of automobilists who entrusted their cars to Weeber for repair. Several names are recognizable as owners of Ford cars.⁵⁰¹

The alternative or supplement to battery ignition was the magneto. A K-W Ignition Company *Bulletin Number Ten* in the Weeber collection at the New York State Museum is a 1909 catalogue of magnetos and coils.⁵⁰² The Weeber Works ordered a magneto from K-W in Cleveland, Ohio, in May 1909. A. F. Williams, K-W secretary and treasurer, wrote a lengthy acknowledgement noting shipment that day or the next by American Express. He went on to explain K-W policy of "opening no accounts with anyone, no matter who they are or however well rated." He explained the need to adjust the old coil, "that is, see that

⁴⁹⁵H-1933.6.327.

⁴⁹⁶W.G. Silver, secretary, to C. F. Weaver Cycle Wks. [sic], September 25, 1907. The Motsinger letter is appended "Note circular on Muffler. Your trade discount on Muffler is 33 1/3% from list." And the letter is marked in pencil, "Wrote for further information 12 21." A circular in the Weeber collection claims that the Motsinger Auto-Sparker "successfully dispenses with all batteries." The text mentions that the Auto-Sparker had been in use for five years. In that case, the flyer predates the Motsinger letter that speaks of the device being used as a battery charger.

⁴⁹⁷Silver to C. F. Weeber Mfg. Co., December 23, 1907. Silver mentioned he could not find correspondence "with your company relating to this matter in our files." Perhaps since he previously had written to the "Weaver Cycle Wks.," a search for letters to Weeber had been unsuccessful. His previous letter did claim the Auto-Sparkers "will sell and make you a profit of 50%."

⁴⁹⁸Mix to C. F. Weeber, April 25, 1908. Mix wrote on the letterhead of James Mix "Watchmaker, Jeweler & Silversmith."

⁴⁹⁹Jones to C. F. Weeber Mfg. Co., July 7, 1909.

⁵⁰⁰The price list is dated July 20, 1909.

⁵⁰¹These names are Reid, Mickle, Klein, Alexander, Dedrick, Posson, Troidle, Bramer, Gleason, Grattan, Brown, George, Nicholas, Barzen, Van Dorn, Deitz, Frier, Happel, Foster, Teitz, Bruns, Ford and Dockstader. Some names appear more than once.

⁵⁰²H-1933.6.240.

the platinum contact points are filed off perfectly clean and level and the vibrators adjusted close to the core with a light even tension. . . .⁵⁰³ An invoice, apparently for this magneto, is dated May 22, 1909. It shows a 25% discount on the \$35 magneto. A sticker showing a face on which is printed the word "THANKS" perhaps portends the rash of "happy faces" that festooned many letters in the later twentieth century.

Williams wrote again a month later to ask why there had been no recent order since "No doubt there are a number of owners who are thoroughly disgusted with battery ignition."⁵⁰⁴ At year's end, K-W had written to ask if the Weeber Works "could or could not handle our agency this year [1910]." With no reply, K-W wrote again in February and forwarded a query from a Mr. Walsh.⁵⁰⁵ Weeber marked the letter "will call Mr. Walsh, Ans. 2/22 Copy." Apparently, Weeber did continue to sell K-W magnetos because on June 28, 1910, Williams forwarded a new discount schedule promising greater profits since jobbers had been eliminated from the distribution system.

Other magnetos Weeber inspected included the American, the product of the American Electric Fuse Company of Muskegon, Michigan and New York City. Traveling representative, O. H. Shade, visited Weeber in May 1909. A follow-up letter offered "to ship you any equipment that will take care of your requirements on 30 days approval."⁵⁰⁶ In 1910, the Remy Electric Company of Anderson, Indiana, wrote accompanying a circular for a new model high tension magneto. Sales manager G. D. Driscoll also sent a list of cars that could be retrofitted with the new device. He noted, "We want to keep in close touch with all distributing agents who are handling cars with Remy equipment."⁵⁰⁷ In August 1910, the Weeber Works bought a Model D magneto from C. F. Splitdorf in New York City for \$65.50.⁵⁰⁸

A blue print drawing in the Weeber collection of a double (magneto and battery) ignition system is marked "LAVALETTE & CO. DEC 11 1907 112-

114 West 42nd St., New York City" as well as "U.S. No. 16. Wiring Diagram For [for] Double Ignition 4 Cylinder Engine." Whether the Weeber Manufacturing Works installed or repaired such an ignition system is unknown here.⁵⁰⁹

Ignition coils were a component prone to failure in auto ignition systems. A major manufacturer of coils, timers and related parts was the Heinze Electric Company in Lowell, Massachusetts. Heinze was a supplier of such parts to the C. F. Weeber Manufacturing Works as early as November 1906, when a \$4.50 "Marine Coil" was shipped via express. Into 1909, Heinze sold Weeber additional coils, timers, brushes, timer knives, contact springs, contact bars, vibrator springs and nuts. The standard discount from the retail prices was 50%. If not shipped by express, the goods were sent by mail. On May 7, 1909, for example, four brushes, eight timer knives and two nuts, with a total list price of \$.84, cost Weeber \$.42 plus \$.02 for postage.

In 1909 the Pfanstiehl Electrical Laboratory in North Chicago offered "on trial any style coil in which you may be interested." The coil could be returned "at our expense" after thirty or sixty days' use.⁵¹⁰

Herz & Company of New York shipped Weeber a timer for a two-cylinder engine "180° ¾ bore" via "Amer. X." to the "Weeber Mfg. Co." at 255 Sherman Street on May 21, 1906. The price of \$15 was discounted 50%. Perhaps this device was intended for use on a Maxwell car for which Weeber's Central Automobile Company was an agent. Two months later, Herz sold the Weeber Works, now located at 172 Central Avenue, miscellaneous electrical parts including wire, cable and terminals, for \$10.38.

An undated catalogue in the Weeber collection at the New York State Museum is from the Pittsfield Spark Coil Company ("Successors to The Jewell Mfg. Co.") of Pittsfield, Massachusetts. In addition to coils, the booklet shows spark plugs and "magneto dynamos" for motorcycles, autos

⁵⁰³To C. F. Weeber Mfg. Works, May 20, 1909.

⁵⁰⁴June 26, 1909.

⁵⁰⁵The letter is dated February 18, 1910.

⁵⁰⁶R. W. Augustine, manager of igniter department, from New York to C. F. Weeber Mfg. Company, May 21, 1909.

⁵⁰⁷To C. F. Weeber Mfg. Works, March 19, 1910.

⁵⁰⁸The invoice, dated August 4, 1910, records shipping via American Express.

⁵⁰⁹Patent number 875,534 was granted December 31, 1907, to Henri De La Valette of Paris, France, who said the "invention relates to magneto-igniting devices for explosive engines, in which the whole of the magneto-igniting device can be swung around its axis of rotation, in either direction, according as the ignition is to be forwarded or retarded."

⁵¹⁰J. M. Troxel, secretary and treasurer, to C. E. Weber Mfg. Co. [sic], August 6, 1909.

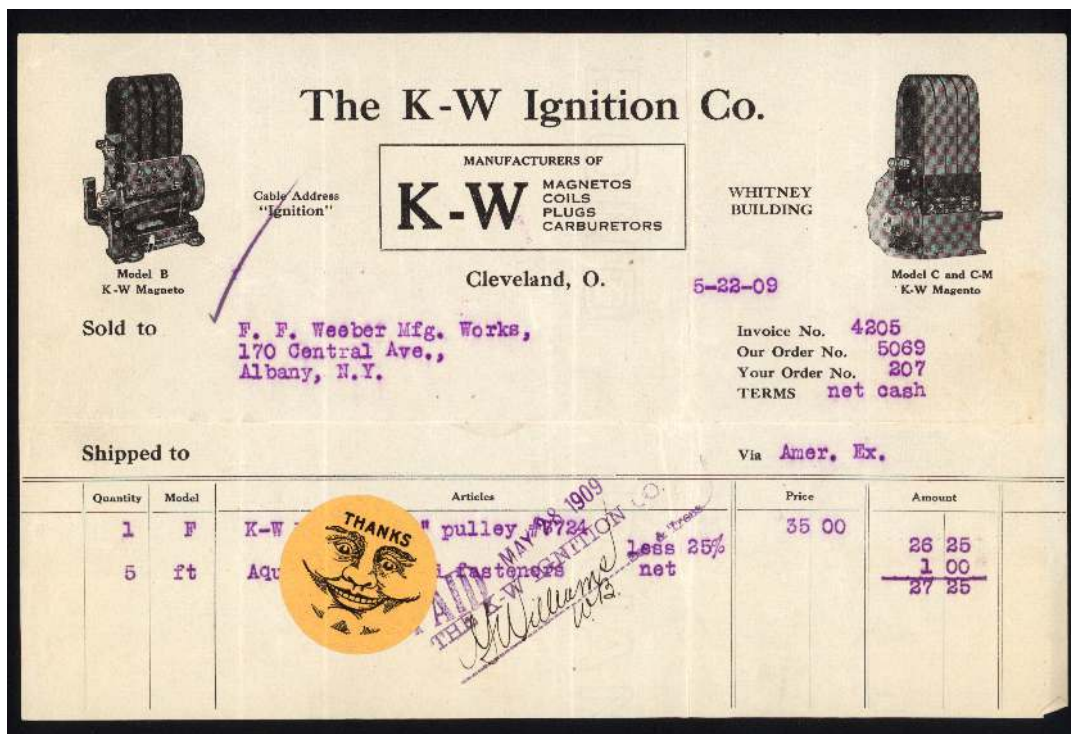

Figure 6.3: Invoice for a K-W magneto shipped in May 1909 via American Express to the Weeber Manufacturing Works, May 22, 1909. Note the Man in the Moon thank you sticker. NYSM Collection, H-2000.39.NN.

and launches.⁵¹¹ The Pittsfield publication probably dates from about 1905.

An instruction booklet for the Atwater Kent Manufacturing Works ignition system dates from 1915.⁵¹² The "Unisparker" was basically a distributor made by the Philadelphia concern. Perhaps the penciled calculations on the back cover showing a ten percent discount reflect a purchase by the C. F. Weeber Manufacturing Works. An instruction manual for the "Electric Starter and Lighter" of the United States Light and Heating Company in Niagara Falls, New York, may indicate the purchase, or sale, of a car fitted with U.S. Lighting motor-generator, regulator and battery that comprised the starting and lighting system.⁵¹³ A 1916 advance catalogue from Paul G. Niehoff and Company ("Metallurgic Research Laboratories") of Chicago offered magneto, generator and coil parts to the Weeber Manufacturing Works.⁵¹⁴

Spark plugs, of course, were essential replacement parts for gasoline-fueled engines. In the summer of 1909, the Weeber Manufacturing Works ordered All-In-One spark plugs "to fit the Model T Ford" from the Comet Electrical Manufacturing Company in Detroit. These plugs retailed for \$1.50 and cost the dealer \$1, with an additional discount for lots of fifty. On a Comet letter explaining the company's terms, Weeber noted, "Wrote & check sent 7/11."⁵¹⁵ Another supplier of spark plugs to Weeber was the R. E. Hardy Company of Brooklyn. It sent 24 Vulcan Plugs listing for \$1.25 at a cost to Weeber of \$14.40, plus 3 "Cadillac Cores" listing for \$.90 but costing Weeber \$.75 on May 5, 1909 with a further 12 Vulcans charged on July 14, 1909.

The Post & Lester Company was a firm responding to a Weeber spark plug query in 1909. Spitfire plugs were \$6 a dozen or \$45 in 100 lots in some sizes; \$9 and \$70 in another. "We can make immediate shipment and should be pleased to be favored with your order."⁵¹⁶ In fact, previous to the

⁵¹¹H-1933.6.261.

⁵¹²H-1933.6.246.

⁵¹³H-1933.6.213. *Bulletin 510-A*, printed in June 1915, superseded *Bulletin(s) 509* and *510*.

⁵¹⁴H-1933.6.176.

⁵¹⁵E.P.H. for the Comet Electrical Manufacturing Company, to C. F. Weeber Mfg. Works, July 7, 1910.

⁵¹⁶Post & Lester Company to C. F. Weeber Mfg. Company, August 18, 1909.

Post & Lester letter, Weeber had purchased two dozen ½" Brown spark plugs at \$.55 each on April 24, 1909. It was followed on April 30 by an order for one dozen each of Soot-Proof (\$7) and "Spit-Fire" (\$6) plugs and another half-dozen Brown spark plugs for \$3.30.⁵¹⁷

A broadside for Red Head sparkplugs from the Emil Grossman Company suggests a source of cheaper (\$1) plugs. "All good dealers are giving us a temporary home until some kind person comes and claims us for the balance of our lives."

A. R. Mosler & Company, on West 29th Street in New York, sold Weeber four Spitfire plugs for \$.15 each plus 4 asbestos gaskets at \$.05 each. All shipped via "Reg. Mail" for \$.13 on June 2, 1909. Six "porcelains" were sent on June 8, adding \$1.03 to the \$.93 bill from the week before. On July 23, Mosler billed for 24 Spitfires, shipped via American Express, for a total charge of \$14.40

E. Q. Williams of Syracuse sold the Weeber firm twelve ½" mica plugs on July 27, 1909, at \$.50 each; twelve more on August 21, 1909; and twenty-four on August 25, 1909. J. H. Bunnell & Company supplied one dozen Delta spark plugs at \$.50 each on July 12, 1909. The Motor Car Equipment Company also sold a dozen plugs, in this case ½" Rajah plugs at \$.70 each on October 12, 1907.⁵¹⁸ The Wilson Trading Company of New York billed for a dozen Splitdorf plugs for \$5.40 on May 11, 1909.⁵¹⁹ Advertising material in the Weeber collection about spark plugs includes a "Torbensen Gear; Incorporated" brochure dated November 1903 for T.G.I. Sparking Plugs and a Anderson Spark Plug Company (Washington, D.C.) booklet marked, perhaps commemoratively, "Jamestown Exposition 1907."⁵²⁰

⁵¹⁷The Post & Lester bill dated April 30, 1909, includes many other items: half-dozen Rapid Cut (\$1.00); dozen tin boxes of cotter pins (\$.1.10); ten pounds of tape (\$2.70), six gas bags (for acetylene lighting use—\$.75); dozen Schmidt (lamp) burners \$1.20); half-dozen Bray Elta burners (\$1); dozen Sampson pliers (\$3.25); half-dozen Giant oil guns (\$2.25); and half-dozen adjustable, eight-inch, "S" wrenches (\$3.50). The total bill was \$33.10.

⁵¹⁸The Motor Car Equipment invoice also billed for 10 feet of 1.5-inch Camel hair [brake] lining at \$.20 a foot and three Michelin [tire] levers at \$.90 each.

⁵¹⁹The Wilson bill also asked for \$1.95 for a "Dia. Sec Tube 30x3 NOT GUARANTEED." Weeber subtracted 5% (\$.09) for cash payment.

⁵²⁰H-1933.6.326A-C and 312. The former is rubber stamped "10% Discount."

Horns, Whistles and Cutouts

Among the pamphlets received from the Weeber estate in 1933 was a 1909 catalogue for Klaxon horns manufactured by the Lovell-McConnell Manufacturing Company of Newark, New Jersey. Whether the Weeber Works sold the "X Ray of Sound" is unknown here but there is a Klaxon horn among the Weeber materials donated to the New York State Museum in 1933. The Klaxons, in electric motor-driven form, were expensive; \$30 and up. A photo in the Klaxon catalogue shows a Pierce Great Arrow car, owned by "J. C. Fitzgerald, Esq." of Albany, fitted with a Klaxon horn.⁵²¹ One might assume that the horn had been fitted by the Pierce agent but a second copy of the Klaxon booklet in the Weeber collection perhaps indicates Weeber was at least interested in selling the horns. Another pamphlet is for the Long Distance Siren, the product of the Sterk Manufacturing Company of Chicago. The hand crank siren was a \$35 alternative to "that poor little 'honk, honk' of your bulb horn."⁵²² Whether Christian Weeber sold any of these sirens is unknown here.

Exhaust whistles were a popular accessory in 1910. Diverting exhaust gas to the whistle produced a loud noise in a single tone or several depending upon the design. The Nightingale Whistle Manufacturing Company, at 1693 Broadway in New York City, promoted their \$7 outfit in 1909. Two solicitation letters and a brochure from 1909 survive in the Weeber collection at the State Museum. While the Nightingale promised "a chromatic scale of bird-like notes" and "a rich melodious trill for town use" that would "if desired...penetrate more than a mile on the road",⁵²³ documentation shows Weeber purchased two units that year from the Gabriel Horn Manufacturing Company in Cleveland, Ohio. His initial order for a No. 3 horn was exchanged for a No. 2, to be fitted to a Ford car in the spring. In July, he ordered another such horn "suitable for a model 'T' car. The attachment of valve on this car should be made before the muffler but as near

⁵²¹Lovell-McConnell Manufacturing Company, *Klaxon Warning Signal*, (Newark, New Jersey, 1909). The booklet notes "KLAXON (roarer) is from the Greek verb 'Klaxo' (to cause to roar or shriek)."

⁵²²H-1933.6.275 and H-1933.6.306

⁵²³The handbill probably dates from the fall of 1909. The letters are dated June 4, 1909 and December 15, 1909.



Figure 6.4: Cutout received by the New York State Museum with the Weeber material removed from the buildings at 168-170-172 Central Avenue. A hole in the exhaust pipe in front of the muffler allowed exhaust gas to flow unimpeded (by the muffler's baffles) through the cutout when the driver pulled a cable opening the lid. NYSM Collection, H-1933.6.40.

to it as possible."⁵²⁴ Weeber also purchased three "Blue Ribbon Motor Chimes—Valves 1½" tube threaded" at \$4 each from the Beckley-Ralston Company in Chicago in August 1909.

Exhaust cutouts were another popular accessory on automobiles of the 1900s. Essentially this created a muffler bypass, as the cutout decreased exhaust back pressure and provided more power from the engine at the expense of noise. In theory the cutout was opened only in sparsely populated rural areas.

One cutout maker, contacted by the C. F. Weeber Manufacturing Works, was the S. B. R. Specialty Company on 54th Street in Manhattan with a factory in East Orange, New Jersey. In response to a query from Weeber, "C. P. N." writing for S. B. R. enclosed a handbill and wrote that the "new discount... is 50%." Retail prices for the cutouts were

⁵²⁴J. F. Gibler, assistant manager for the Gabriel Horn Manufacturing Company, to C. F. Weeber Mfg. Works, May 7, 1909 and July 13, 1909.

\$3.50, \$4 and \$4.50.⁵²⁵ Whether Weeber ordered any of the patented devices is unknown here.

Weeber did purchase cutouts from the R.I.V. Company of New York City. An order dated August 5, 1909, was filled and sent by express on August 6, when R.I.V. secretary H. S. Neats wrote in response to a Weeber query:

Regarding discounts would say that we are giving you now the same discount as given the Auto Supply Co., and all the New York jobbers and appreciate what you are doing with the sale of these cutouts but at the present time it is impossible to do any better in the discount line. Should we, in the future, be able to take care of you any better, we shall be pleased to advise you.⁵²⁶

Bills in the Weeber collection at the State Museum document purchases from R.I.V. on October 27, 1908 (cutouts at \$5.50 and \$3.75) plus two control levers at \$2 each for a total of \$9.55 less 5% for payment within ten days; two cutouts on May 21, 1909 at \$3.75 each less 40% less another 5% for payment within ten days for a total of \$4.28; three cutouts at \$3.75 each on June 12, 1909; two for \$3.75 each less 40% but not the additional 5% for a total of \$4.50 on July 10, 1909; two on July 26, 1909 for the 40% plus 5% discount for a total of \$4.28; two on August 4, 1909 for \$4.50 total after the 40% discount; six on August 6, 1909 at \$3.75 each subject to the 40% and 5% discounts for a total of \$17.10 (after the previous \$4.50 charge was added); and six on August 25 subject to the double discount for a total of \$12.83. Weeber also purchased R.I.V. ball bearings, apparently five-hundred ("5/C") of item "(407)" in July 1909. The charge was \$13.75 less 50% and then less 2%. R.I.V. in 1909 shipped via American Express.

Speedometers, Clocks and Other Instruments

Automobile speedometers often were aftermarket accessory items. Speedometer catalogues as well as invoices and Weeber correspondence from 1908

⁵²⁵C.P.N. for the S.B.R. Specialty Company to C F. Weeber Mfg. Works, February 3, 1910. A patent, 942,011, dated November 30, 1909, for a "muffler cut-out for explosive engines" was assigned to the S.B.R. Specialty Company by Louis Raffalovich of New York City, who claimed ease of installation. "All that is necessary to do... is to provide a suitable opening in the exhaust pipe and my invention clamped thereon in the manner described or in any suitable way."

⁵²⁶To C. F. Weeber Mfg. Works, August 6, 1909.

and 1909 with several manufacturers and distributors of such instruments survive at the New York State Museum. A Parker Manufacturing Company (Boston, Massachusetts) catalogue and installation manual depicts \$30 to \$65 standard speedometers.⁵²⁷ A firm with which Christian Weeber dealt was the Warner Instrument Company of Boston and Beloit, Wisconsin. In January 1908, Weeber returned an "Auto-Meter" to Wisconsin for adjustment; A. E. Moon, writing for the Warner Instrument Company, said, "We always desire to get in close touch with our customers if anything is wrong, our satisfied customers being our best advertisement."⁵²⁸

A few days later, Arthur H. Brown, manager of the Warner operation in Boston, wrote to announce that his company had instituted a policy of giving dealers a 25% discount on Auto-Meter parts. Heretofore, dealers and end users had been charged the retail price for parts "not by any means to crib a profit from the dealer but to avoid any possible errors in equipment through indirect dealing." Now, with much greater demand, "We feel it is only just to make the dealer a discount so that he will not have his labor for his pains in these cases."⁵²⁹ Two additional letters from Brown discuss the repair of a speedometer with a broken shaft (January 28, 1908) and the fitting of a customer's clock to a speedometer (February 3, 1908). He advised that it would be necessary for the clock to be sent to the factory. Or he could have a different clock installed "and then accept the other instrument in exchange with the cash difference. . . The price of the instrument with clock and light attachments is \$125.00 or \$50.00 more than the price of the regular instrument."

In the spring of 1908, Weeber was dealing with the Auto Improvement Company, maker of "Ever Ready" speedometers at 316-322 Hudson Street in New York City. C. P. Browne, writing for Auto Improvement in April, noted shipment of an order "with the exception of the one instrument which is to be mounted on a show-board" since he was waiting for a "fresh consignment of show-boards within a day or two." He apologized for a delay in shipping the remaining items but "the Runabout, being a new instrument with us this season, we

have not been able to turn out enough to supply the demand."⁵³⁰ In August 1909, R. W. Crary [illegible?], General Sales Manager, wrote about a "Cyclemeter" returned for credit. "We find that there is absolutely nothing wrong with the instrument. . . Under these conditions, we hardly feel like issuing credit for this instrument, and would like to know if we shall ship it back to you for your stock."⁵³¹

Surviving bills from the Auto Improvement Company include one from April 17, 1909, for two "Runabout Twins" speedometers for left hand drive Model T Fords at \$30 each and an eighty-mile per hour "Mileometer" for a Thor motorcycle at \$15. The \$75 total bill was discounted 40% and subject to a credit of \$26.67. Thor motorcycles, it should be noted, were sold by Christian Weeber's brother, Emil at a bicycle and motorcycle business adjacent to the Weeber Manufacturing Works on Central Avenue. On June 7, 1909, Auto Improvement shipped via Wells Fargo Express an exchange head for a 1909 "old style" Runabout for no charge. On August 13, it sent a repaired Mileometer new style head, also at no charge via National Express.

In 1908, Weeber was doing business with another major maker of speedometers, the Stewart & Clark Manufacturing Company in Chicago. A booklet in the Weeber holdings at the State Museum describes the "1908 Improved Models" with consumer prices ranging from \$25 to \$75.⁵³² In March 1908, Weeber shipped a swivel joint for repair, a job producing two exchanges of letters to clarify the problem.⁵³³ The next year repairs were done to a speedometer at no charge according to a five-year guarantee. A \$1 was charged for a new brass cup, the old one "being somewhat the worse from contact with grease and subjection to the elements. We thought that your customer would be much better pleased if we would send him a new Cup, at the special price of \$1, thus making his Instrument present an entirely new appearance rather than for us to return it in the old dirty look-

⁵²⁷Undated pamphlet, H-1933.6. 311.

⁵²⁸To the C. F. Weeber Mfg. Works, January 13, 1908.

⁵²⁹Brown to C. F. Weeber Mfg. Works, January 25, 1908.

⁵³⁰To C. F. Weeber Mfg. Works, April 30, 1908.

⁵³¹To F. Weeber Mfg. Works, August 13, 1909. Weeber has marked on the Crary letter in pencil, "Ans. 8/14/09 Copy" but not indicated his thoughts on the proposed return.

⁵³²The booklet has State Museum accession number H-1933.6.271.

⁵³³F. O. Fleischer to C. F. Weeber Mfg. Works, March 31, 1908 and April 1, 1908.

ing condition.”⁵³⁴ Later that year Weeber corresponded with a New York City branch of the Stewart & Clark concern at 1878 Broadway regarding repairs.⁵³⁵

In June 1909, Stewart & Clark billed the Weeber firm \$2 for repairing a flexible shaft. Christian Weeber noted on the bill, “Chg. to Mr. Brown,” apparently referring to the owner of the speedometer being repaired. In July, Stewart & Clark, from their New York City office, shipped via American Express a shaft with a swivel joint for \$11.50 and a dash bracket for \$1, both discounted 25%. And on August 20, 1909, in response to a telegram order the previous day, a set of gears was mailed to the Weeber Company from New York for a charge of \$2.06. The bill was paid on October 21.

A local dealer in Stewart speedometers was the Albany Hardware and Iron Company, which wrote to the C. F. Weeber Mfg. Co. [sic] on June 15, 1909, to advise that Albany Hardware had “just received a supply of Stewart Speedometers, Models 11 and 12, retailing at \$25.00 and \$15.00. Can make prompt shipment and would be pleased to receive your orders.” In April 1909, Weeber also purchased two Stewart speedometers, “‘30’ #11 Mod. T. Ford,” at \$16.67 each from the Post & Lester Company.⁵³⁶

By 1915, there was a “Stewart Products Service Station” at 338 Central Avenue. A Stewart installation manual in the Weeber collection at the New York State Museum, with information about 1915 and earlier speedometers, has the Stewart service station address and telephone number on the cover.⁵³⁷

Another important source of speedometers was United Manufacturers of New York City, distributor of the Jones speedometer. Weeber communicated with United in June 1909 about a replacement part, which was “broken beyond repair and will supply you with a new one, without charge,



Figure 6.5: Photograph of sales sample of Stewart Model B speedometer, c. 1910, on a stand for use in selling from the C. F. Weeber Manufacturing Works facility on Central Avenue in Albany. This deluxe instrument has a device to indicate the pitch of the grade the vehicle was climbing or descending. NYSM Collection, H-1933.6.58.

and return to you today.” A few weeks later, Weeber forwarded an additional order.⁵³⁸

In July, United Manufacturers sent Weeber, at his request, a parts price list. In August he received a list of the speedometers, clocks and horns available for the 1910 season. The document noted that “1909 trade discount quotations will NOT apply on 1910 Line prices. We shall be pleased to quote revised discounts on application.”⁵³⁹ In September 1909, Weeber was sent a “Jones Speedometer Banner” for his show room. “If you are selling too many Speedometers, you won’t care for it. If not, you want it and you want it bad, and you want it on the most conspicuous wall space you’ve got, because it’s great.”⁵⁴⁰ Photographs of the Weeber plant in the 1909-1910-period show a Jones Speedometer sign attached to the exterior of the glass booth in the southwest corner of the show-room.

⁵³⁴The writer’s last name, “R. S. W. . . .,” is illegible. The letter is dated May 17, 1909.

⁵³⁵F. M. White to C. F. Weeber Mfg. Works, July 7, 1909; H. O. Fleisher, July 19, 1909; H. O. Fleischer, August 17, 1909; F. M. White, August 24, 1909.

⁵³⁶Post & Lester shipped via express. Weeber paid the April 3 bill on June 14, 1909.

⁵³⁷H-1933.6.297.

⁵³⁸Jones Speedometer Department to C. F. Weeber Mfg. Works, June 29, 1909; United Manufacturers to C. F. Weeber Mfg. Works, June 28, 1909.

⁵³⁹G. L. Holmes to C. F. Weeber, August 2, 1909.

⁵⁴⁰G. L. Holmes to C. F. Weeber, September 21, 1909.

A Stewart & Clark letter to the C. F. Weber [sic] Mfg. Works from June 10, 1909, discussed a Jones Speedometer Company letter claiming a Stewart centrifugal speedometer infringed on a Jones patent. The Stewart message said, however, "The claims of the Jones Speedometer Co. are really too absurd to justify any detailed denial on our part. We operate under Patent No. 855676, granted us on June 4th, 1907...It is our sincere belief that this action has been brought for no other purpose than to bolster up the declining trade of an inferior speedometer." The controversy prompted the Hoeffcker Company in Boston, makers of the "Steady Hand Speedometers," to write the Weeber firm about "Speedometer Litigation." Mentioning the involvement of three speedometer makers "in a legal tangle regarding the priority of patent claims," the Hoeffcker Company said its positions was "ABSOLUTELY IMPREGNABLE. Our patent claims are intact and the dealer as well as the consumer are in NO DANGER OF BOTHER in using the Hoeffcker Speedometer...Prices range from \$35 to \$125. Get our 1910 quotations, they will interest you."⁵⁴¹

Weeber pursued purchase of automobile clocks without speedometers from the American Electrical Novelty & Mfg. Company in New York City, which referred an order to the Albany Hardware & Iron Company, "distributors for us of these instruments" and from the Motor Car Equipment Company in New York, which sold its Continental Clock for \$3.50 in the month of May 1909 only, the regular price being \$3.75. "We trust that if are in the remain."⁵⁴² For repair of automobile clocks, Weeber could turn to Cass M. Krammer at 25 Central Avenue in Albany. He fixed an "auto clock movement" and ground glass to fit for \$.75 on August 11, 1909. A handbill for the "Lewis Nojar Rubber Retained Auto Clock" in the Weeber collection at the New York State Museum likely dates from 1916.

In 1918, the Weeber Manufacturing Works apparently was selling Boyce Moto-Meters. At a minimum, the Weeber concern was involved with the repair of these thermometers, which indicated engine cooling system temperatures from fittings

⁵⁴¹F. M. Rollins to C. F. Weeber Mfg. Co. [sic], August 18, 1909.

⁵⁴²H-1933.6.270. The text describing the stem-wound clocks notes a March 28, 1916, patent date.

atop radiator caps. A card in the Weeber collection at the New York State Museum is a Moto-Meter repair and replacement parts price list "subject to regular trade discounts" effective March 1, 1918. Pinned to the list is a business card for J. K. Dalton, "representing" the Moto-Meter Company of Long Island City. On the card in pencil, probably in Dalton's hand, is marked, "OK Exchange 2 Lids" [the last word is indistinct].

Windshields and Tops

Windshields and tops often were aftermarket items. Christian Weeber's correspondence file shows that he purchased accessory windshields in the 1908-1909 period. A letter from the Troy Carriage Sun Shade Company in Troy, Ohio, claims, "...it is a pleasure to form your business acquaintanceship" and acknowledges an order "given our Mr. Pervear specifying for one No. 5 Front to be shipped at once." B. Horn, the company secretary, continued letting Weeber know his organization was "well equipped with the Ford B/P's and considering the number of cars you have sold since January 1st we are certainly in position to do a great deal of business with you." Apparently, Weeber had alluded to his car sales with his order letter.⁵⁴³ A fine, 1909, twenty-four page, Troy Carriage Sun Shade Company catalogue survives in the Weeber collections at the New York State Museum. The Number 5 front is identified as "A Genuinely Good Low-Priced Pattern" and "No Cheap Make-Shift."⁵⁴⁴

United Manufacturers, at Broadway and 76th Street in New York City, responded to two Weeber orders, numbers 259 and 446 (United Manufacturers orders M-10218 and M-10910) in June and August of 1909 respectively for "Automatic" windshields. Apparently, the first was too small for its intended use. United wrote in August that they were "informed by our Factory that they will make shipment immediately." Seemingly, Weeber asked about returning the smaller windshield. United thought, "Of course, it would be to the advantage of both of us, were you to find a purchaser for the

⁵⁴³B. Horn to C. F. Weeber Mfg. Wks., March 9, 1908. The author surmises that "B/P's" refers to blueprints, i.e., the Troy firm was prepared to fabricate a front without the need for Weeber to measure the car in question.

⁵⁴⁴Troy Carriage Sun Shade Company, "Troy Automobile Fronts" (Troy, Ohio, 1908 or 1909), p. 15.



MODEL No. 5—Continued

A GENUINELY GOOD LOW-PRICED PATTERN
NO CHEAP MAKE-SHIFT

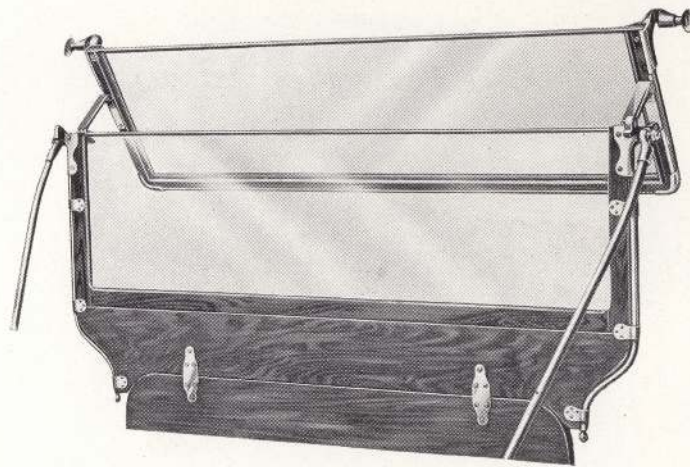

Double Hinge Joint permits upper section to fold **INSIDE** without interfering with the steering wheel.

A steel plug countersunk in each end of the supporting fixture receives the locking thumb-screw and makes wear and rattle impossible. (See also description of "Light Six" on Page 3.)

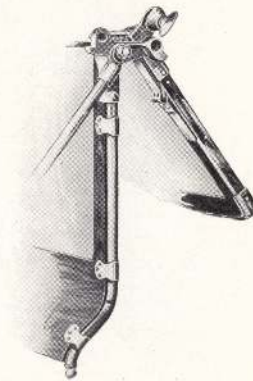

See Pages 14 and 16.

Page fifteen

Figure 6.6: The Troy Carriage Sun Shade catalogue, 1909. Christian Weeber ordered for a customer, probably for installation on a Ford car. Folding windshield, listed complete with filler boards, sold for \$40 complete. NYSM Collection, H-1933.6.231.

Shield you now have on hand. Should you, however, be unable to dispose of this Shield, through sale, you may return same, well packed, addressed to our factory, C. A. Mezger, 1629 Broadway, New York City."⁵⁴⁵

Christian Weeber heard from C. A. Mezger, Inc., a few weeks later when treasurer R. M. Owen wrote of an injunction against the New York Sporting Goods Company "for selling an infringement of the Automatic Wind Shield." This, Owen promised, was one of "only the first steps in our campaign of maintaining our rights and protecting you in your legitimate profits on the sale of windshields." Owen concluded his letter by noting that until the creation of the Automatic, which sold at \$67.50, there had been no demand for windshields. Now the Automatic cost "the amazingly low price of \$25, for this price we will continue to furnish the highest grade materials throughout, including French Plate Glass."⁵⁴⁶

Owen wrote again in March 1910, enclosing a copy of a decree signed by Judge John F. Philips of the Circuit Court of the United States for the Western Division of the Western District of Missouri. It was regarding the matter of C. A. Mezger, Incorporated versus the Pioneer Auto Top & Supply Company forbidding Pioneer from infringing on the windshield patent, number 917,752 granted to Edwin K. Conover and assigned to C. A. Mezger, Inc. Owen said the Mezger patents "broadly cover Automatic and all other folding windshields. Several more important cases now pending in the courts are being pressed to an early decision."⁵⁴⁷

The Conover patent, assigned to C. A. Mezger, Incorporated, has among its objects the possibility of adjustment without the driver leaving his seat and the quality of being "easily adjusted to its raised or lowered position, and automatically lock[ing] in either of said positions." The mechanism used projections to engaging detents secured with springs to lock the windshield in place. To adjust the windshield, the driver needed only to apply enough pressure to overcome the pull of the springs.

⁵⁴⁵Charles Rubel for United Manufacturers to C. F. Weeber Mfg. Works, August 7, 1909.

⁵⁴⁶Owen to C. F. Weeber, August 25, 1909. The decree, according to Owen, was signed by Judge Lacombe of the United States Circuit Court, Southern District of New York, on July 26, 1909.

⁵⁴⁷Owen to C. F. Weeber, March 16, 1910.

Another supplier of windshields was the Emil Grossman Company at 232 W. 58th Street in New York City. Emil Grossman, president of the concern, himself wrote to the Weeber Manufacturing Works in August 1909, to announce "the biggest advertising campaign ever undertaken on windshields." The Grossman company was about to send out 50,000 letters and catalogues to some of the 250,000 automobile owners in the United States. In particular, Grossman was going to push the "HYDRAULIC" windshield. A follow-up letter listed prices for both hydraulic and spring action windshields. The former retailed at \$30 or \$32.50, according to width; the latter at \$25 or \$27.50. The dealer discount was 25% on five windshields or less in one delivery; 33½% for five or more; and 40% for a contract for 100 with specific delivery dates. In all cases, an additional 5% was allowed for cash. "...we hope you will take advantage... by placing your order NOW so that you may not lose sales as you did the past season."⁵⁴⁸

The seller of the Auto Pneumatic Glass Front, the Automobile Equipment Company of Detroit, offered its \$40 product discounted at 35% with an additional 5% off for cash FOB Detroit. Terms were "10% with order, balance C.O.D. or sight draft attached to bill of lading. Open account ten day settlement at well rated houses." The maker claimed, "You hardly have to demonstrate it" since the windshield would sell as soon as the customer saw it. The "air cushion makes it proof against accidental breakage by dropping."⁵⁴⁹ If replacement glass was needed, the Hires Turner Glass Company of Philadelphia was ready to supply it, even though "American Plate Glass factories are hopelessly choked up with orders for WIND SHIELD GLASS." The reason was that such glass was a factory "by-product." European factories, on the other hand, "can manufacture Wind Shield Glass exclusively if necessary" and Hires had "close associations" with those factories. In an April 1910 letter, Hires asked Weeber for a "list of your requirements."⁵⁵⁰ Another windshield supplier, whose handbill was retained by the C. F. Weeber Manufacturing Works, was the

⁵⁴⁸Emil Grossman to Weeber Mfg. Works, August 26, 1909 and August 31, 1909.

⁵⁴⁹C. A. Carey for the Automobile Equipment Company to Weeber [sic] Automobile [sic] Works, May 14, 1909.

⁵⁵⁰S. C. Gilmore, secretary, to Weeber C. F. Mfg. Wks. [sic], April 30, 1910.

Limousine-Carriage Manufacturing Company of Chicago, "Sole Manufacturers of the [\$60] Schild-back Divided Windshield."⁵⁵¹

Weeber also received solicitations for his top business. The Michigan Top Company in Detroit, becoming the center of the American automobile industry, offered both \$45 mohair and \$32.50 Fairfield Auto Rubber Duck tops as well as tops in "Morrocoline (Imitation Leather)" and "Pantasote (Genuine)."⁵⁵²

Another manufacturer was the Detroit Motor Car Supply Company, which for 1909 offered the Wishbone Rival Top of waterproofed duck for \$39.50, complete with side curtains and storm front "for one or lots of 100."⁵⁵³ For 1910, Detroit offered Fairfield rubber, English mohair and Pantasote versions of its tops. For runabouts, Fairfield's complete cost was \$39.50. The other two materials were \$49.50. An undated letter said the Detroit firm had "1,000 measurements of 1908-1909- and 1910 cars. We could cover Noahs Arc if Noah would fill out the measurement blank. It is easy and simple. We have [sic] also, measurements of many cars as far back as 1903." An additional Detroit message claimed it "makes the twenty-fourth (24th) letter we have sent you explaining our plan of selling Auto Tops to dealers." Detroit Motor Car supposedly was "not discouraged as we have most of the dealers buying from us at the present time" shipping 100 tops per day. But "we want some more orders from you."⁵⁵⁴

⁵⁵¹H-1933.6.277. The flyer is undated. However, the photo shows a portion of a 1908-1910 period car without front doors. Limousine-Carriage also made auto bodies and tops and did "general carriage work." A pamphlet promoting custom bodies of the Limousine Carriage [without the hyphen] Manufacturing Company, H-1933.6.309, also is part of the Weeber collection at the New York State Museum. One of the cars depicted is a Model K Winton, i.e., a 1906 model. Perhaps Christian Weeber picked up this booklet at a Chicago auto show. The Weeber collection also includes two identical undated handbills advertising "High Grade Automobile Bodies" built by the Buffalo Auto Body & Trimming Company at 338 Ellicott Street in Buffalo. H-1933.6. 386 and 387.

⁵⁵²Unsigned letter to C. F. Weeber, February 2, 1910. The year is not indicated on the letter but the attached circular is for the 1910 season. It shows carriage tops as well as equipment for automobiles. Pantasote tops are the most expensive followed by mohair, Morrocoline and Fairfield rubber in that order. Pantasote was an artificial leather made of coated fabric.

⁵⁵³Handbill H-1933.6.247.

⁵⁵⁴Incomplete, undated 1910 letter to C. F. Weeber Mfg. Works; letter signed by sales manager (illegible signature be-

Still another top manufacturer, whose 1910 catalogue⁵⁵⁵ made its way to the Weeber Manufacturing Works, was W. H. Newton & Son of Cortland, N.Y. At the publication date, January 1, 1910, Newton claimed to have specifications for many popular makes of 1910 cars as well as those for recent Ford, Maxwell and E.M.F. models, all of which Christian Weeber had or would sell. Newton charged \$5 extra for work for which there were no measurements of the car on hand. Top prices ranged up to \$99 for a "Fancy Mohair" extension touring car top, both without storm front or sides. A Sterling Top and Equipment Company, Inc. (New York City), catalogue lists "topping outfits" for 1914 through 1918 cars requiring replacement of top covering material to fit on extant bows.⁵⁵⁶

The Nathan Novelty Manufacturing Company supplied Weeber with covers for folded automobile tops. A special size rubber cover, shipped via American Express, cost \$3.00 in April 1909; two rubber covers to fit Model T Ford tops were sent at \$2.50 each in June 1909; and another at \$2.50 was sent via National Express in August 1909.

In May 1909, the Vehicle Apron & Hood Company of Columbus, Ohio, makers of top covers, lamp covers, robes and horse covers among other products, answered a Weeber query by mailing a catalogue as well as indicating in a letter that the dust hoods in which Weeber had expressed interest were shown on "page 4 of this book." Further, "Our discount to you will be 50% from the price quoted there in."⁵⁵⁷

License Plates

Until 1910, automobiles registered in New York were required to display the registration number on a license plate furnished by the registrant. The standardized format required a white field with black characters. Overall size was 15" x 6" with

ginning "L. E. . . ." to Weber [sic] Mfg. Wks., May 20, 1909. These two items are part of accession H-2000.39.

⁵⁵⁵*Newton Tops 1910* is H-1933.6.264.

⁵⁵⁶H-1933.6.234. The Weeber collection also includes an undated handbill advertising Sterling "Winter Automobile Equipage" as well as the repair and rebuilding of automobile bodies. H.1933.6.272.

⁵⁵⁷A. S. Celucker [?] to C. F. Weber, May 10, 1909.

EMIL GROSSMAN COMPANY

MANUFACTURER OF

Hydraulic and Springaction Wind Shields

Red Head Spark Plugs etc, etc.

DETROIT BRANCH
874 WOODWARD AVE.

232 WEST 58TH STREET

CHICAGO BRANCH
1436 MICHIGAN AVE.

New York, August 26, 1909.

Weeber Manufacturing Works,
Albany, N. Y.

RE: WIND SHIELD CAMPAIGN.

Dear Sirs:

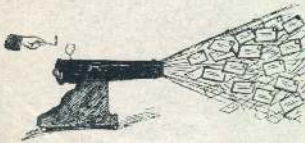

On September 5th we will fire the first gun in the biggest advertising campaign ever undertaken on wind shields. We will send out the first series of 50,000 letters and HYDRAULIC Shield catalogs to the 250,000 registered owners in America. In conjunction with this we will conduct a vigorous campaign in the leading automobile magazines and trade papers.

Of course this represents an enormous outlay and you may be sure we would not assume this expense if The HYDRAULIC did not possess undisputed superiority over all other makes. You know what gratifying results we achieved in our campaign on RED HEAD Spark Plugs--we will eclipse that success.

Get your order ready.

Yours very truly,

EMIL GROSSMAN COMPANY,

Emil Grossman
President.

Figure 6.7: Emil Grossman letter, August 26, 1909. Note the illustration where the cannon is shooting a load of campaign mail. NYSM Collection, H-1933.6.NN.

the numbers 4" high by 1 1/16" wide.⁵⁵⁸ In 1909, the C. F. Weeber Manufacturing Works purchased supplies for producing license plates from the N. Stafford Company at 67 Fulton Street in New York. On March 25 of that year, the Works bought six "auto pads" (providing the field for the plate at \$.40 each); six "N.Y." figures to identify the state of registration (\$.07 each); and six sets of figures (\$.70 each). On April 30, they bought six license hangers (\$.40 each) and 34 figures (\$.07 each). On June 5, the purchase was six hangers and 28 figures (at \$.09 each). On June 21, it was six hangers and 67 figures (\$.07 each); on July 12, six pads and 33 figures (\$.07); and on July 21, six pads and 28 figures (\$.07 each). A letter from the Stafford Company, dated August 11, 1909, says, "thanks for your check duly received also let us know whether you do not need some more badges and figures."⁵⁵⁹

Miscellaneous Parts and Accessories

In the winter of 1908, Germain Hogan, who manufactured metallic packing in a Troy factory, contacted Christian Weeber to promote a "Timer Bracket" for Ford runabouts. In a letter to "Mr. Weeber Mfg. Works," Hogan wrote:

We are sending some Folders of Timer Bracket for Ford-Runabout, they are going to sell well we have made up ten which are all sold are making up 100 and will have them out soon The price is \$8.00 less 25% to agents. How would you like to have the agency for your territory? Trusting you will consider the matter favorably, I am⁵⁶⁰

Weeber marked Hogan's letter, "Ans. 3/24 will try to sell." Apparently, some time passed before Hogan was able to deliver a bracket. On April 17, he wrote:

I went to your Garage last evening with one of the "Timer Brackets but you had gone, and I left it with the Saloon keeper across the street from you, with the understanding that

⁵⁵⁸New York State Department of Motor Vehicles, "Motor Vehicle and Driver Registration in New York State" (Albany, 1988).

⁵⁵⁹The Stafford letterhead notes the company, "established half a century," could supply bronze and other metal signs, medals, stencils, inks, rubber stamps, steel stamps among other items.

⁵⁶⁰Germain Hogan, March 2, 1908. The letterhead reads, "Germain Hogan Manufacturer of Sterling Metallic Packing Office and Plant 180 Fourth Street Troy, N.Y."

he would see that you got the same today, no doubt you have rec'd it. Trusting you will be able to do some business, I am.

What response Weeber made to this second surviving Hogan letter is unknown here.

Also in 1908, Weeber dealt with Eugene Arnstein in Chicago, a manufacturer and distributor of automobile accessories and bicycle fittings. On March 21, 1908, Arnstein wrote to ask about payment for bills dated February 29 and March 2 for a total of \$18.70. The letter is marked by Weeber in pencil, "Ans. 4/23." Having received partial payment, the Arnstein firm, in its own letter of April 23, acknowledges receipt of \$18.05 and then responds to Weeber's "remarks relative to Oil and Grease gun". Arnstein acknowledged an error in shipping a more expensive, "Aluminized Gun" instead of a Japanned finish model specified in a March 2 invoice. Arnstein was not going to press for the \$.65 difference (\$3.40 versus \$2.75) but "on the gun forwarded to you on Feb. 29th, we must say that we cannot allow you a better price than \$3.40, and would thank you to favor us with your remittance of 65c."

The final two paragraphs of the Arnstein letter deal with Weeber's comments about a draft made against the Weeber Manufacturing Works. Unfortunately, Weeber's letter is not available for analysis. Arnstein's observations on payment, and the apparent slow response to other creditors as shown by dates of billing and payment, suggest that Christian Weeber was slower rather than quicker to pay. While Weeber has marked the Arnstein letter, "Ans. 4/28," his response to the following also is unavailable.

We also note your remarks relative to our drawing draft upon you and in connection with this, we wish to advise you that on April 1st we sent you a statement of your account saying that if you had not remitted by the 13th we would take it for granted that it would be all right to issue a draft upon you. It is a strict rule with our collection department to notify all our customers before drawing upon them, and we regret very much to note that you desire to sever connections with our house for future business. While we appreciate your business and it is our desire to have a continuance of same, we think that if you will investigate our statement you will find that we are correct.

It has always been our desire to serve you to the best of our ability and any orders that we have had the pleasure to receiving from you have always had our prompt attention. We trust the contents of this letter will tend to reverse your opinion regarding future relations with our house.

Thanking you for your remittance, and awaiting your further advice, we beg to remain...⁵⁶¹

On March 7, 1908, Christian Weeber wrote to the Hayes Manufacturing Company in Detroit to inquire about tool boxes. In receipt of a March 9 replay and a circular from Hayes, Weeber marked the incoming letter with a list of items he subsequently ordered. In columnar form there are 12 items under an "Ordered 3/14" heading. Whether these all were tool boxes is not clear, since the objects are identified by letters rather than descriptions, e.g., "B," "T" and "W."

A second Hayes letter states that the supplier was "in receipt of your favor of the 14th and note specifications for the tool boxes on order given our... Mr. Emmons in February." Emmons himself was author of the communiqué and continued:

We have also entered your order for one set of Motor Specialty guards at \$8.50, enameled black, but would state the price of \$8.50 was quoted on the basis of ten sets. If you find these guards meet with your requirements and are satisfactory, we shall expect future orders to be in lots of at least ten sets.

Please bear in mind that we would like to have you give us a few days notice on future orders as we are sometimes held up by other stuff going through the factory.⁵⁶²

At the end of the 1910s, as the C. F. Weeber Manufacturing Works neared the end of its period as a new car agency, Christian Weeber, in a more mature automobile industry, dealt with a new group of parts suppliers. For example, the Weeber collection at the New York State Museum has a late 1918 or early 1919 catalogue of "Povasco Steering Wheels & Radiator Caps," the products of the Pouvailsmith Corporation in Poughkeepsie.⁵⁶³

⁵⁶¹E. Riort (illegible signature?) writing for Eugene Arnstein, April 23, 1908.

⁵⁶²Hayes Manufacturing Company "Per E" to C. F. Weeber Mfg. Works, March 9, 1908; E. D. Emmons, sales manager, to C. F. Weeber Mfg. Works, March 17, 1908.

⁵⁶³H-1933.6.302. A few 1919 model cars are listed with their radiator cap requirements.

Other Supplies, Services and Sublet Repairs

Perhaps Christian Weeber's order for *Who Makes What* published by the *Hardware Dealers' Magazine*, was intended as a means of supply for the production of his automotive specialties. Or perhaps it was for access to material of a more general nature needed in the course of running an auto agency. Weeber ordered a copy of the annual "book of reference for buyers and makers. A directory of manufacturers, products, jobbers, wholesalers, foreign merchants and export commission houses and buyers," in the late spring of 1909.⁵⁶⁴

Weeber secured miscellaneous standard hardware items for use in auto repair from a variety of suppliers. Some suppliers were located some distance from Albany. In March 1909, for example, he purchased 15,000 cotter pins in six different sizes for \$15 less 67.5%⁵⁶⁵ from the Auto Supply Company on Broadway in Manhattan. A later order for 3,000 more cotter pins unfortunately went astray and the Company wrote to request "that you kindly furnish us with the order number of same."⁵⁶⁶

Local hardware dealers also supplied the Weeber Company. In 1909, G. V. & F. W. Cameron at 284 Central Avenue, just west of the Weeber Works, maintained a Weeber account. From February 1 to July 14, a bill of \$26.56 had been run up. In July Weeber added a piece of circular glass (\$.25); a box of 1½ x ¼ stove bolts (\$.38); one-quarter pound of shellac (\$.75); six skate straps (\$.30); a piece of circular fitted circular glass (\$.30); three [steel] pulleys (\$.15); one brass pulley (\$.10); 2.5 yards of brass chain (\$.25); and one 10" circular glass (\$.25), making a total bill of \$29.29, which was paid on August 11, 1909. The Albany Iron and Hardware Company also provided a variety of goods, such as, two pounds of tapped ¾" hex nuts (\$14); five

⁵⁶⁴A letter concerning Weeber's order of the reference book was signed by Daniel T. Mallett of the *Hardware Dealers' Magazine* on June 8, 1909.

⁵⁶⁵The order also included six #25 wrenches at \$.36 each and three #21 wrenches at \$.24 each before discount.

⁵⁶⁶T. H. Adams [illegible?] for the Auto Supply Company, July 30, 1909. Weeber marked the letter, "Ans. 7/31 By (B.) Copy." The later Auto Supply invoice is dated June 11, 1909. The \$3 total for cotters in three different sizes was discounted 75%.

pounds of ½" hex nuts (\$10); and one 2" "Muffler S B R Cut Out" (\$5.50); all subject to a 25% discount.

In 1907, the National Sewing Machine Company of Belvidere, Illinois, sent a form letter informing the Weeber Works that National was a manufacturer of "all kinds of special washers, hubs, pins, bushings, shafts, studs, rollers, nuts, bolts, etc. also set and cap screws" as well as "Gray iron castings."⁵⁶⁷ In 1913, the New Departure Manufacturing Company of Bristol, Connecticut, sent Weeber, along with a letter praising New Departure ball bearings, the "'New Departure Ball Bearing Manual' for dealers and garage men."⁵⁶⁸

In 1909, the Weeber company bought fifty "1½ x 2¼ x ⅜ SS Clips, Black" from the firm of C. Cowles & Company in Hartford, Connecticut. The July 30 order was billed on August 5 and paid on October 16. The clips were discounted 70% and a further 10% decreasing the nominal \$10.25 charge to \$2.77. A 1907 Cowles *Catalogue of Automobile Trim-mings, Mountings and Hardware* in the Weeber collection at the New York State Museum has check marks opposite a number of listings for automobile spring clips, including "Special Size" clips made to order.⁵⁶⁹ The only clips given the 70% and then 10% discount are "Automobile Short Spring Clips." None of the Cowles clips in the catalogue, however, match the size given on the bill.

In April 1909, the Weeber firm purchased 9.5 feet of cable from Robert B. Wing & Son, ship chandlers in Albany. The \$.29 bill was paid with "Stamps." During the following summer, two more lengths of cable and one of wire on three invoices totaled \$.88, the last one marked in pencil, "Send Stamps." In 1911, the Weeber Works purchased 145 feet of manila rope for \$1.53 from M. G. Stoneman & Son in Albany.⁵⁷⁰

On July 15, 1909, the Weeber Works wrote to the Woven Steel Hose and Rubber Company of Trenton, New Jersey, asking for "Lining" (one assumes brake lining) to be delivered on July 17 in Albany. J. R. Kelso, Woven Steel manager, in writing on July 17, noted that Weeber's letter had not

⁵⁶⁷F. L. Goodrich, manager of contracting department, to C. F. Weeber Mfg. Wks., December 27, 1907.

⁵⁶⁸Unsigned letter to C. F. Weeber Mfg. Works, September 16, 1913.

⁵⁶⁹H-1933.6.194. The laid in price list is dated July 15, 1907.

⁵⁷⁰The February 17 transaction saw the Weeber firm acquire 45 feet of ⅞" rope and 100 feet of ¾". Payment by means of postage stamps was not unusual.

been mailed until the 16th and it was "impossible for us to have this lining in Albany today but we will get it off at once and hope that the delay will not inconvenience you."⁵⁷¹ A month later, Weeber wrote to the Empire Automobile Tire Company, also in Trenton, about brake lining. A letter from Empire's New York City office followed "as you happen to be in our territory. We are sending you under separate cover a sample of our Brake Lining and would be pleased to get some of your business. We will give you 50% discount from list prices, with 5% for cash ten days on all Brake Lining purchases."⁵⁷² A 1918 catalogue of clutch facings from the Raybestos Company of Bridgeport, Connecticut, shows dealer and consumer prices for automobile, truck and motorcycle clutches.⁵⁷³

Welding, soldering and machining were undertaken at the Weeber facility. Letters soliciting Weeber business survive from firms dealing in soldering fluid (George Callahan & Company in New York, 1910); flux for brass and aluminum founding (Sandoval Zink Company of East St. Louis, Illinois, 1909); McAdamite metal, a brass and bronze substitute (United States McAdamite Metal Company of Brooklyn, no date); bar iron (Milton Manufacturing Company of Milton, Pennsylvania, 1909); brass and copper fasteners (U. T. Hungerford Brass & Copper Company of New York, 1909); chrome nickel and nickel steels (Cyclops Steel & Iron Works of Sheffield, England, through a New York agent, 1910); and drill rods (New Process Steel Company of Lancaster, Pennsylvania, 1909). The Weeber Works, probably in late 1907, purchased "one box of our aluminum solder" from the Aluminum Solder and Refining Company of Owego. H. L. Conde, company president, wrote in January 1908 to ask "if your trial of this product was satisfactory, and if you are in a position to use any more?" Weeber marked the letter "Ans. 1/24," but a second, similar Conde letter followed in March 1908. A booklet in the Weeber collections describ-

⁵⁷¹The Weeber collection at the New York State Museum also has a Woven Steel Hose & Rubber Company "Blue Edge" brake lining price list with the name of the distributor imprinted on it, that of Scully & Brandt, Inc., in Manhattan. Christian Weeber marked the brochure "6/27/18," suggesting a continuing interest in Woven Steel products. The brochure also includes information about clutch facings and various Woven Steel hoses.

⁵⁷²"J. H." for the Empire Automobile Tire Company to C. F. Weeber Mfg. Co., August 25, 1909.

⁵⁷³H-1933.6.293.

ing aluminum solder and flux manufactured by E. F. Lester in Fayetteville has been pierced, perhaps for hanging as a handy reference.⁵⁷⁴

Welding supplies sold to the C. F. Weeber Manufacturing Works in the 1906 through 1909 period came, at least in part, from Peter A. Frasse & Company in New York City. In August 1906, Frasse shipped 12¼ pounds of #10 brass wire and 5 pounds of brazing flux (\$5.19). On February 21, 1907, another 21.25 pounds of spelter wire cost the Weeber firm (at 255 Sherman Street) \$5.95. On February 1, 1909, 13.75 pounds of spelter wire and five pounds of Hotalings' brazing flux were \$4.98. Another five pounds of Hotalings' flux and ten pounds of spelter were \$1.40 and \$2.80 respectively on July 8, 1909. Eighteen pounds of wire at \$.26 a pound cost \$4.68 on August 5, 1909. Five pounds of Hotalings' flux at \$.28 per pound were \$1.40 on August 27, 1909.

On July 20, 1906, the Weeber Works were billed for 28 pounds of Magnolia Metal, for use as a bearing material, at \$.25 a pound less 20% shipped via National Express by the Magnolia Metal Company of New York City. Late in 1907, Weeber probably ordered "a small quantity" again. In January 1908, E. C. Robson, Magnolia assistant secretary, wrote to ask "relative to further business."

Weeber replied two months later, on March 19. Next Magnolia president E. C. Miller wrote to say the Weeber letter was "something of a surprise." Apparently, Weeber had said that he was unable to secure Magnolia Metal from the Albany Hardware [and Iron] Company. Miller assured Weeber that Albany Hardware "does sell considerable Magnolia Metal in Albany, but if you prefer to have us ship your metal direct, we shall be very glad to do so."

We note that some time back in order to deliver a small shipment promptly our traveler did turn same over to the Albany Hardware Co., for execution, but if you will look the matter up you will find we invoiced direct to you.

There was certainly no intention to refuse to accept any order of yours, and if you care to favor us further with a requisition, or an op-

portunity to quote you, we shall appreciate it very much.⁵⁷⁵

In February 1910, Robson wrote again to ask if the Weeber firm might be "in need of anything in the line of Babbitt metals" and enclosed a pamphlet about Magnolia Metal. "We have furnished you this grade in the past and you have no doubt been able to discern it [sic] superiority over any other metal on the market. We are prepared to furnish same as heretofore 20 cts per lb."⁵⁷⁶

In January 1908, the Weeber Works ordered 200 feet of ¼" annealed copper tubing and some brass tubing from the Waterbury Brass Company in Waterbury, Connecticut. A letter in response said that Waterbury was referring the order to the Benedict & Burnham Manufacturing Company "of this city."

We take this action as we have given up the manufacture of tubing of any kind and the company mentioned are now handling whatever small orders we receive for same. We think you will appreciate the fact that you will receive better service by dealing directly with the mill manufacturing the goods.⁵⁷⁷

An order in February 1908, from Peter A. Frasse & Company in New York, either for metals, tools, auto parts or a combination of these lines, "went astray." Francis G. Dyken, writing for the Frasse firm, reported that a "representative of the Express Company called today" to ask for a bill for the value of the lost material. Dyken asked Weeber whether "it will be satisfactory to have us do so, or do you prefer to present the claim yourself. . . . Shipment will be made today of the second lot."⁵⁷⁸ Weeber noted on the letter, "Ans. 3/2 asked to send bill to Ex. Co."

⁵⁷⁵Miller, as president and general manager, to C. F. Weeber Mfg. Works, March 20, 1908. An invoice dated July 31, 1909, for 21.25 pounds of Magnolia Metal at \$.22 a pound purchased from the Albany Hardware and Iron Company, survives in the Weeber collection at the New York State Museum. The bill was paid on September 23, 1909.

⁵⁷⁶Miller to C. F. Weeber Mfg. Co., February 5, 1910.

⁵⁷⁷A. W. Percey to C. F. Weeber Mfg. Works, January 24, 1908.

⁵⁷⁸Francis G. Dyken to C. F. Weeber Mfg. Co., February 24, 1908. A Frasse & Company letter (C. M. Conrad, cashier) dated March 17, 1908, asked for payment for the successful delivery (the express company having settled "with you"). Weeber marked this letter, "Ans. 3/18 Check sent 3/18." A final surviving Frasse letter (George Stadtmuller, April 9, 1907) wished "to hand you corrected statement as per our books and we find that the original one showing a balance of \$3.89

⁵⁷⁴H-1933.6.343. The booklet was "our catalogue for 1906 to the trade."

Drills for working in metal were vital in the automobile repair business of the 1900s. The Albany Hardware and Iron Company sold C. F. Weeber at 170 Central Avenue two $2\frac{5}{64}$ S S drills at \$.18 each and one $\frac{3}{8}$ drill at \$.17 as well as a half-pound of #10 ounce cut tacks for \$.07 on October 24, 1906. The bill was paid on December 3. In March 1907, the Weeber Works purchased two chuck keys, useful for drills and lathes, from the Jacobs Manufacturing Company of Hartford, Connecticut, for \$.30 each discounted 30% plus \$.13 for postage.

In addition to the purchase of new drill bits, grinding machines could be used to prolong the life of used drills. In 1909, the Heald Machine Company of Worcester, Massachusetts, maker of the American Twist Drill Grinder, wrote to the Weeber Auto Manufacturing Company, that, "We are advised by our Mr. Frost who called upon you on the 26th inst., that you were interested to a certain extent in the matter of drill grinders." A catalogue was sent "under separate cover" and an offer made for Weeber to test a machine.⁵⁷⁹ At about the same time, Edgar T. Ward & Sons of Boston wrote to promote their Capital Tough Brand of high speed drills.⁵⁸⁰ A year later, the United States Electrical Tool Company of Cincinnati wrote the Weeber firm to praise the "U.S. electric drills and grinders." The tools "run off of the ordinary lamp socket, either direct or alternating current." A machine was offered on a trial basis; "if not a time and labor-saver, return it to us at our expense."⁵⁸¹ In August 1909, the Union Twist Drill Company of Athol, Massachusetts, responded to a Weeber query not about drills but about gear cutters. While Weeber sought a cutter for a gear with ten teeth, Union responded that such a tool would have to be specially made for \$6.50; the regular cutter for 15 teeth was \$3.00 less 33 $\frac{1}{3}$ %. Weeber marked the Union letter, "order #7 10P 7/8" hole [order #] 8 [10 P] . . . Write Copy 8/17."⁵⁸²

Also in 1909, Weeber received a letter from the Townsend Woodstock Company, "contract woodworkers" in North Manchester, Indiana.

was through an incorrect addition on our bookkeeper's part." Weeber marked this letter, "Ans. 4/18 want itemized bill."

⁵⁷⁹C. N. Coneau [illegible?], secretary, to Weeber Auto. Mfg. Co., March 29, 1908.

⁵⁸⁰G. R. Osgood to C. F. Weeber Mfg. Co., February 29, 1908.

⁵⁸¹George H. Filtes to C. F. Weeber Mfg. Co., June 2, 1909.

⁵⁸²J.H.D. for the Union Twist Drill Company to C. F. Weeber Mfg. Co., August 6, 1909.

We are advised that you are buying specially machined woodwork for your line. If our information is correct, it seems to us that we should be able to interest you; at least we should be glad to have a place on your list and to receive your inquiries.

We are not prepared to furnish bent stock, but in any other branch of the business our equipment is complete.

If there is anything at the present time in which you feel we could interest you, we would be glad to send our representative to call on you at your Albany Office.⁵⁸³

What led the Woodstock Company to write to Weeber ("C. F. Weeber, Jr.") is unknown here. Apparently, Weeber was interested in the Woodstock offer for he marked the letter "8/23 Copy Write."

Materials for gaskets and packing were essential to the work of the Weeber firm. Thus in June 1906, Weeber received one yard of $\frac{1}{32}$ " "Autobestos" sheet packing for \$4.31 from the Keascey & Matison Company of Ambler, Pennsylvania. In July 1906, six pounds of "Vaporite" was received from A. W. Chesterton & Company of Boston, makers and jobbers of steam packings. In response to a query from the Weeber Works, the Garlock Packing Company of Palmyra, in an initial letter, quoted prices for Style 900 sheet [packing] on which letter Weeber noted instruction for an employee to "order about 1 yard $\frac{1}{32}$." A second Garlock letter recorded shipment, via express, of almost three pounds of $\frac{1}{32}$ " Garlock sheet material for \$3.97, a sum received by Garlock in early September.

One of the earliest price lists surviving in the Weeber collection at the New York State Museum is that dated August 1900 from H. M. Grant, supplier of "Hard and Flexible Fibre Sheets for Electrical and Mechanical Purposes." Heavily soiled and stained, the brochure has on it a series of numbers in a column recorded in pencil.

In November 1906 and August 1907, the Delaware Hard Fibre Company of Wilmington, Delaware, sent 99 pounds of fiber material at prices ranging from \$.20 to \$.33 per pound, depending upon thickness. In April 1908, Delaware Hard Fibre wrote to the Weeber Works that their "order of the 8th received and will have our prompt and

⁵⁸³H.T. for the Townsend Woodstock Company to C. F. Weeber, Jr., Albany, N.Y., August 17, 1909.

best attention. Thanking you for the same, we are,
Yours truly.”⁵⁸⁴

In November 1907, J. Spaulding & Sons Company, “manufacturers of high grade fibre,” wrote:

We do not wish to worry you with our letters but we do want your business. We have written you several letters and they possibly have annoyed you a little. We do not want to trouble you but we are this persistent because we are very anxious to get started with you.

When you are next in the market, will you not write us for quotations, whether for Hard Fibre Sheets, Rods, Tubes, Washers or Special Shapes?⁵⁸⁵

Weeber wrote in pencil on the Spaulding letter, “Ordered 12 /9 ½’ [inches] x 12” x 36.” Interestingly, Spaulding sent the very same text in a letter dated July 7, 1909. This time Weeber simply acknowledged reading it with a pencil oval mark. Asbestos wicking came from M. G. Stoneman & Son in Albany in January 1907 at a cost of \$.34 per pound for ten pounds plus \$.35 for an express charge.

Leather, apparently for upholstery use, came from Philip Sternfeld, an Albany wholesale dealer in leather, findings and shoe supplies. In January 1907, by example, he sold a side of elk leather totaling 15¼ square feet to the “Weber Automobile Works” for \$9.92 plus \$.35 for “expressage.” In April, another piece of leather, slightly larger, cost the Weeber firm \$11.56, including delivery. In October 1906, G. Adolph Poppe, a harness maker at 176 Central Avenue, supplied the neighboring Weeber concern with three “new straps” at \$.20 each.⁵⁸⁶

Wipers were essential to a manufacturing and repair operation such as the Weeber Works. In July 1906, Weeber purchased a bale of “U. S. Wipers.” The 107 pounds of cloth cost \$16.05 at \$.15 per pound. For washing automobiles, the Phoenix Oil Company of Cleveland contacted the Weeber Works in early 1910, offering Murphy’s Oil Soap in quarter, half and full barrels at \$.075, \$.07 and

\$.06 per pound, respectively, “strictly on a trial basis delivered to your railroad station.”⁵⁸⁷

Contracted Repairs

A bill for goods and services sold to the C. F. Weeber Manufacturing Company during 1909 demonstrates that at least some specialized welding, as well as repainting of automobiles, was contracted to other concerns. William L. Schupp and Sons billed \$103.91 for work and materials from January to the beginning of December. Payment came in the form of “Credit on our acct” with the bill stamped “PAID Dec. 4 1907, C. F. Weeber Mfg. Works per” and marked by hand “A.C.” [?].

A large portion of the work in the Schupp account is for welding of spring leaves but there was also \$27.16 for making truss rods. Refinishing of a “Red Ford auto” cost \$10, although the Weeber Company bought much paint material from Schupp for its own use, including 92 pounds of white paint for \$16.56 and 15.5 pounds of black paint for \$3.88. Weeber also purchased iron, e.g., “4½ pounds of 1” band iron” on October 8, 1907.⁵⁸⁸

E. J. Hayes’ Troy Spring Works on Congress Street in Troy sold and repaired many springs for the Weeber firm. The earliest surviving bill in the Weeber collection at the New York State Museum dates from May 17, 1906, when “2 only 1½ x 8 like old spg.” were sold for \$2. Repairs in 1907 included four on February 21 (\$3.25); two on April 5 (\$2); and two on June 12 (\$2.50). In 1909, three springs were repaired on March 8 (\$5); two on March 16 (\$5); 1 on March 27 (\$3); two on March 30 (\$6); two on April 3 (\$5); one on April 7, (\$2.50); one on June 17 (\$2); and four on July 15 (\$10.50). Springs sold included three 1½ x 7 Ford rear springs (\$8.50 on July 15) and six Ford front springs (\$15 on August 9). All of these Troy Spring Works charges were billed again on September 2 and paid on October 30, 1909.

⁵⁸⁴Unsigned letter to C. F. Weeber Mfg. Works, April 10, 1908.

⁵⁸⁵“Dict. by H. N. S.” to C. F. Weeber Mfg. Works, November 26, 1907.

⁵⁸⁶The building at 176 Central Avenue would shortly be occupied by Emil Weeber’s bicycle shop.

⁵⁸⁷Unsigned letter to C. F. Weeber Automobile Works, March 17, 1910.

⁵⁸⁸Who “A.C.” is, if indeed those are the initials on the bill, has not been determined here. The Schupp billhead notes that the concern primarily was engaged in carriage building. On April 2, 1909, Walker & Gibson, wholesale druggists in Albany, billed C. F. Weeber \$1.65 for a gallon of “Interior Cycle Enamel Blk.”

Apparently in the summer of 1909 Weeber turned to Knox & Schaible, carriage manufacturers, for spring repairs on Spruce Street in Albany, more convenient for Weeber. Charges for repairing a single spring were \$1 each on August 13 and August 31, while on September 8 the cost for repairing a spring with two new leaves was \$2. Knox & Schaible also billed for covering top bows and sticks (\$4 on September 21) and for painting an auto (\$18 on August 28).

While not obligatory for motor vehicle operators, liability insurance was available in the 1900s in case of collisions as well as for theft, fire and other damage. M. Richardson, who supplied Christian Weeber with advertising material, represented several different companies.⁵⁸⁹ Cantine & Rice, also in Albany in 1909, were agents for the American Fidelity Company of Montpelier, Vermont. For insuring an individual operating a twenty-horsepower auto, such as the Ford T, for up to \$10,000 in an accident causing injury or death to two or more persons, the cost was \$29 per year. Additional drivers added to the premium, e.g. 15% more for another driver, 25% for two more.⁵⁹⁰

Whether Christian Weeber was in a position to profit by recommending insurance agents to his customers or whether the insurance material he preserved was solely for his personal use is unknown here. Weeber was, however, approached by the National Surety Company of New York with an opportunity to sell automobile bail bonds on consignment. "The arrest and detention of Automobilists for exceeding the speed limits and other alleged infractions of the local laws has made them very popular." The "powers" were available in a "neat, compact form in books of two" good for up to \$500 for one year at a cost of \$15 a set. "If you desire to accept the sale of same, kindly advise us at once and we will send you all the necessary information. The commission we allow is 25%."⁵⁹¹

⁵⁸⁹Richardson is identified only by his first initial and surname in the city directories for 1908, 1909, 1912 and 1914. In 1908 and 1909, he was resident manager for the Aetna Life Insurance Company at 112 State Street. In 1912 his title was assistant manager.

⁵⁹⁰See sales material in the Weeber collection at the New York State Museum.

⁵⁹¹H. S. Simon for National Surety Company. No inside address. No date but probably 1909 or 1910.

In-House Repair Business and Brief Look at the Used Car Business

While some repair jobs were farmed out by the C. F. Weeber Manufacturing Works, many were performed by the Weeber concern itself. It's likely that Christian Weeber's talent and experience as an engineer and machinist prompted others to turn to him when seeking particularly difficult work executed. Perhaps that is what caused Stanley L. Reed & Company in Elizabeth, New Jersey, to write to the Weeber Manufacturing Works in 1908 looking for a steering gear for a 1907 Mitchell. The Reed firm, similar to Weeber, was an agent for Ford cars. One might surmise that the Ford Motor Company branch in New York, after declining to provide such a part, suggested that Reed write to Weeber. The Reed letter is very specific about the dimensions of the needed part, e.g., "This gear must stand an angle of 49° 15,' Length of shaft from where gear bolt on frame 3 ft 11½."

"In quoting please give full particulars as to construction and material. Please send catalogue of your line." Weeber noted in pencil, "Ans. 3/3" and "Circular enclosed."⁵⁹² One wonders why Reed did not contact the Mitchell Motor Car Company in Racine, Wisconsin, directly for a part to fit a one-year old model.

Surviving bills from Thomas B. Jeffery & Company are among the earliest surviving documents of the Weeber automobile repair business. In May 1906, the C. F. Weeber Manufacturing Works, at 255 Sherman Street, was billed \$8.95 for Model K (1904) Rambler governor and exhaust parts. Remittance was to be made to "our representative for your locality," the Homan & Schulz Company in New York City. Three more Jeffery bills from May and June 1906 suggest the work was extensive. Model K suspension, brake and rear axle parts totaled \$30.15 less a 15% discount. Rather than the factory in Kenosha, Wisconsin, which had mailed the first bill, now it was the Jeffery New England branch in Boston requesting payment.⁵⁹³ A Rambler parts list booklet in the Weeber collection at the New York State Museum has pencil notations

⁵⁹²Stanley L. Reed & Co. to Weeber Mfg. Works, February 24, 1908.

⁵⁹³The four repair bills are dated May 5, 1906, May 26, 1906, June 4, 1906 and June 16 1906. The first (\$8.95) bill was not discounted.

on a listing for a “hub inside flange, and axle brake drum” for a Model K at \$3.50 as well as marks indicating interest in “Hub ball cup, inside bearing” (\$.25) and “Ball cup, outside bearing” (\$.15) among other parts.⁵⁹⁴

Other 1906 repairs were made to one or, less likely, two Kensington cars. On August 1, the Weeber Manufacturing Works purchased a Kensington bevel gear and rack for \$12 from the Taylor Automobile Company in Albany. Then, on November 30, the American Roller Bearing Company in South Framingham, Massachusetts, billed for a Kensington bearing at \$3.75 as well as “repairs on bearing returned” for \$1.90.⁵⁹⁵

The Weeber Manufacturing Works promised prompt repairs if the evidence of a 1909 telegram is typical. That telegram and a letter in response suggest the speed with which shipment of goods could take place. Apparently sent to McCord and Company, a lubricator manufacturer in Chicago, on Thursday, September 9, the wire requested, “Mail today small bevel pinion gear to fit oiler on nineteen eight S Buick; please have here Friday A.M.” Unfortunately, McCord needed to forward the telegraphed message to the McCord Manufacturing Company in Detroit, “as they are handling all of the automobile business formerly handled by this Company.” The September 9 McCord letter noted that the writer “fear[s] it will be impossible for them to get the gear to you Friday morning.”⁵⁹⁶

In the early years of the twentieth century, steam and electric autos competed for customers with cars powered by gasoline fueled-internal combustion engines. While there is no record of the C. F. Weeber Manufacturing Works selling or repairing steam-engined vehicles (and one should remember Christian Weeber fabricated model steam engines as a Pratt student), in 1909 his company did work on an electric car. In 1909, the Columbia Motor Car Company of Hartford, Connecticut, wrote that Weeber Works acknowledge receipt of a letter informing the Columbia firm of “pending... by

⁵⁹⁴Ibid.

⁵⁹⁵Kensington Automobile Company production had ended at Buffalo in 1904. It’s unlikely there were many such cars in Albany and vicinity.

⁵⁹⁶Morrill Dunn, McCord and Company vice president, to C. F. Weeber [sic] Mfg. Works, September 9, 1909. Dunn’s name is listed in the 1908 city directory as vice president and secretary of the McCord concern. The signature on the letter to Weeber is difficult to read. The typist’s code at the bottom of the letter, “MD-L,” confirms Morrill Dunn’s identity.

express prepaid broken parts for an Electric. We note you wish us to forward you duplicate of same...” A few days later, Columbia reported, “The parts you have returned have been sent to our Repair Department, and will be taken care of promptly.”⁵⁹⁷

While a dealer for several makes of cars over a decade and a half, Christian Weeber nevertheless sometimes turned to suppliers other than car manufacturers for parts. Certainly, when a part was a replacement for an item originally fabricated by a company other than the assembler of the car, looking to a secondary supplier made sense. So in 1907, the Weeber Works communicated with Robert Bosch New York, Inc. regarding a magneto for a Ford. A Bosch letter from February 1908 followed a message two months previous with the information that “our Bosch High Tension Magneto, type ‘D A 2,’ can be used, in connection with a special distributor which you will have to provide...” The price was \$40 less 20% “[a]s we understand you are agents for Ford cars” with a further 2% for cash with the order. Weeber noted on the Bosch letter, “Wrote for magneto for Van How[?] 4/6.”

In 1909, Weeber ordered “two halves of white bronze bearings for the crank pin end of connecting rod. 1¾” in diameter x 1⅞” face”⁵⁹⁸ from the Brennan Motor Manufacturing Company of Syracuse, makers of gasoline engines for automotive, marine and stationary use. What engine used this bearing and the type of installation in which the engine was used are unknown here. Perhaps an auto with a Brennan engine was being repaired. Or perhaps Weeber was working on a boat engine. Several marine supply catalogues survive in the Weeber collection at the New York State Museum.

In August 1907, the Weeber Works ordered one quart of Radium Decarbonizer from the General Accumulator and Battery Company of Milwaukee.

⁵⁹⁷F. Gilcrest, parts order department, to C. F. Weeber Mfg. Works, August 6, 1909; H.A.C. for the Columbia Motor Car Company to C. F. Weeber Mfg. Company, August 9, 1909. In May 1908, the Albany Automobile Exchange at Lark and State Streets in Albany had advertised for sale a used Columbia Electric Victoria that had “run 300 miles; will be sold as a bargain. Good as new. Demonstration at any time.” See *The Argus*, May 31, 1908. One wonders if this might be the same vehicle the Weeber Works repaired a year later.

⁵⁹⁸Unsigned letter to “C. F. Weeber, Albany, N.Y.,” July 24, 1909. Weeber marked the letter in pencil, “Did they arrive?”

A letter of instructions from General Accumulator ended with an implication that “representation for New York” might be available to Weeber.⁵⁹⁹ What experience the Weeber firm had with the Decarbonizer, a liquid poured into an engine cylinder to clean it, is unknown here.

Two 1917 order forms for Burd High Compression Piston Rings document a Weeber parts supplier in the later 1910s. Actually the Burd Company, of Rockford, Illinois, had a branch at 1060 Madison Avenue in Albany, where C. F. Weeber exchanged four rings for eight of a different size.⁶⁰⁰

In late 1910, as Weeber relinquished his status as a Ford agent, he ordered a carburetor, manifold and other parts for a 1909 Ford Model T from the manufacturer of the carburetor, the Stromberg Motor Devices Company in New York City. The 1909 Ford, probably belonging to B. Hennessey,⁶⁰¹ originally had been equipped with a Kingston or Buffalo carburetor⁶⁰² rather than a Stromberg. The new carburetor, a Type A-#1 costing \$22.50, required a different manifold at \$6.75 as well as other parts for \$1.90. The total bill for the items shipped via American Express was \$31.15 subject to a 20% discount. Weeber, noting on the invoice, “as per statement ans. Paid,” determined a further subtraction of 80c. While the bill, dated December 8, 1910, was subject to a further discount of 5% if paid before December 17, Weeber, as apparently was his custom, delayed payment even beyond the normal 30-day period for the net amount. The bill is marked “Pd. 1/25/1.” Another carburetor repair in the same period was to a Schebler device,

⁵⁹⁹Wm. [illegible?] J. Schubert for General Accumulator, to C. F. Weeber Mfg. Works, August 21, 1907. Schubert’s letter also called Weeber’s attention to “our batteries, and can quote you a discount at this time, should we be favored with an order.” The bill for the Decarbonizer also is dated August 21, 1907. The price was \$1.50. Shipping was via U.S. Express.

⁶⁰⁰Both orders are dated June 26, 1917. They document delivery of the rings to the Weeber facility at 170 Central Avenue. The Burd salesman of record was A. C. Preston. The price of 3.5 inch diameter rings was \$1.25 subject to a 30% trade discount. The larger, 3⁷/₈” rings returned for credit retailed at \$1.50. The order forms in the Weeber collection at the New York State Museum are accompanied by a brochure giving installation instructions.

⁶⁰¹The Stromberg invoice is marked in pencil under a typed “Ford Model ‘T’ 1909” notation, “B. Hennessey.” The Albany city directory for 1910-1911 lists no “B. Hennessey.” There is a Burtice Hennessey, a carpenter working and residing at 534 Morris Street.

⁶⁰²Kimes and Clark, p. 576.

the product of Wheeler & Schebler in Indianapolis. The carburetor, apparently belonging to a Mr. Heidenrich, was repaired at no charge and shipped back to the Weeber Manufacturing Works via express.⁶⁰³

Surviving documents point to Christian Weeber’s involvement with the repair of automobiles for which stocks of repair parts were nonexistent. Consequently, replacing broken parts was a particular challenge. In August 1909, for example, Weeber wrote to the Covert Motor Vehicle Company in Lockport looking for a “large bevel drive gear.” The reply from Covert indicated that the special order gear would cost \$10 and “as the gear manufacturers are so busy on regular work it would be impossible to have one of these made up, short of from 6 to 8 weeks after receipt of order.”⁶⁰⁴

A month later, the Weeber Works wrote looking for a shifting yoke for a Covert Chainless Runabout. This time the response noted that since production of the car had ended “some 5 or 6 years ago, we now have very few extra parts on hand, . . . but as this [yoke] is made of bronze, you should be able to readily make one of these yourselves.”⁶⁰⁵

Weeber wrote once more in September asking for a cone clutch casting. While Covert did not have any in stock, they could “procure one of these for you, promptly. . . .” The piece would be made to order of manganese bronze at \$.35 per pound with a total weight of ten to fifteen pounds. A postscript told the Weeber firm that Covert was “entirely out of cones and lock nuts for the ball bearing for the clutch adjustment.”⁶⁰⁶ Weeber noted in pen-

⁶⁰³The Wheeler & Schebler invoice is marked in pencil, probably, “Heidenrich.” The Albany city directory for 1910-1911 lists toolmaker Charles Heidenrich, who worked at 55 Madison Avenue and resided at 26 Irving Street. There also are several men named Heidenreich and Heidrich. Of the former group, John Fred Heidenreich, operator of the Waterville Laundry at 289 Central Avenue, perhaps is the likeliest auto owner. Of the latter group, perhaps architect Charles Heidrich is the likeliest.

⁶⁰⁴E. J. Futton for the Covert Motor Vehicle Company to C. F. Weeber [sic] Mfg. Co., August 29, 1909.

⁶⁰⁵B. V. Covert to C. F. Weeber Mfg. Works, September 14, 1909.

⁶⁰⁶B. V. Covert to C. F. Weeber Mfg. Co., September 29, 1909.

cil, "Phoned Mr. Forst that they have none in stock."⁶⁰⁷

In December 1909, Weeber wrote to the New Process Raw Hide Company in Syracuse, still looking for what New Process identified as "one bevel gear such as we understand this to be (70 tooth for Covert runabout)...". This could be provided "\$15.00 net, terms 30 days, delivery 6 to 8 weeks."⁶⁰⁸ Weeber noted on the New Process reply, "1/14 wrote to Covert to see if he is going to get any..." On January 15, E. J. Futton, secretary of the Covert Company, wrote in response to a Weeber letter from the previous day to say that "we have as yet not been in a position to secure any of the larger Runabout gears, and would suggest that you send your large gear to the New Process Raw Hide Co....believing they might have some forgings in stock from which they could make this gear for you. If not, they no doubt would be able to make this gear for you, of bronze."⁶⁰⁹ Weeber noted in pencil on the Covert, "Wrote Forst 1/19 Copy" and "ordered 3/2 Copy."

The last document of the months-long effort to secure the Covert gear is a New Process letter from March 4, 1910. In it, chief engineer W. H. Diefendorf acknowledges a Weeber letter "of the 10th [sic] to hand" and tells Weeber he could get no "better price than previously quoted. It would take at least 4 to 6 weeks to get this gear out and we should have the old gear to work by." Weeber noted in pencil he, "Decided to try without."⁶¹⁰

Another relatively exotic repair the Weeber Works attempted was to a Gyroscope engine, a device using a vertical crankshaft. Apparently, the requisite crankshaft was unavailable from the auto maker, the Blomstrom Manufacturing Company in Detroit, so in March 1910 Weeber wrote to the Standard Connecting Rod Company in Beaver

Falls, Pennsylvania. In reply, Standard acknowledged the request for price and delivery noting that it would need a sketch showing stroke, diameters and length overall before it could "name you our best terms and price. The best delivery we could name you this shaft would be from July 1st to 15th."⁶¹¹ Seemingly dissatisfied with this information, Christian Weeber noted on the Standard letter, "Write to Anderson Co."

In the Weeber collection at the State Museum is a Gyroscope catalogue complete with a cross section drawing of the engine. Stamped with the name of a selling agent, the S. H. Peterson Automobile Company in Chicago,⁶¹² the booklet also is marked in ink on the cover with "Dr. E. E. Finch, East Greenbush N.Y." Perhaps Finch was the car owner.⁶¹³ And perhaps there is an indication of the date of the Weeber letter to the Blomstrom Company in a pencil notation, likely in Weeber's hand, on the Gyroscope cover: "wrote 2/25" with an additional illegible word.

In April 1908, Weeber sought a radiator. The Hayes Manufacturing Company in Detroit noted he needed it for a two-cylinder car "about the same design and style as that used on the Maxwell." Perhaps it was for a Maxwell that Weeber needed a replacement. If so, one wonders why he did not order one from Maxwell itself. In any event, Hayes said, "we have never made hoods or radiators for the Maxwell and have nothing in stock of this particular style." Hayes did have a radiator for a two-cylinder Jackson available for \$30 FOB. Or with a suitable blueprint, Hayes could "make up anything special for you."⁶¹⁴ Weeber noted in pencil on the Hayes letter, "Wrote [illegible?] Mr [illegible?] Hilfrank [illegible?] Castleton N. Y. 4/28 \$40oo [\$40.00] FOB [freight on board] Albany."

⁶⁰⁷A check of the Albany city directories, including the section for Rensselaer, revealed no resident named Forst in 1909 or 1910.

⁶⁰⁸W.H. Diefendorf, chief engineer, for The New Process Raw Hide Company, to C. F. Weeber Mfg. Works, January 1, 1910.

⁶⁰⁹Futton to C. F. Weeber Mfg. Works, January 15, 1910.

⁶¹⁰Diefendorf to C. F. Weeber Mfg. Wks., March 4, 1910. A New Process bill dated January 2, 1907, documents sale of a "Steel Ber [illegible?] 20 into 10 T. 4233S.P. 1¹/₈..." for \$8. The author assumes the "T" refers to teeth on a custom made gear(s). Weeber marked the invoice "OK CFW."

⁶¹¹John Gillen [illegible?] for Standard Connecting Rod Company to C. F. Weeber Mfg. Works, March 18, 1910.

⁶¹²H-2000.39.86.

⁶¹³Frederick S. Kollé, ed., *Physicians' Who's Who New York State Section* (New York: Physicians' Who's Who Publishing Company, 1913), p. 114, has a listing for Elmer Ellsworth Finch of East Greenbush. Finch was born in Coxsackie in 1866. His medical degree (1886) was from the Albany Medical College. His office was at Schodack Center.

⁶¹⁴E. D. Emmons, Hayes sales manager, to C. F. Weeber Mfg. Works, April 23, 1908.

One might wonder how Christian Weeber's correspondents learned of his work and why they contacted him from afar, for example, Rev. John B. Smith, president of the Mary Allen Seminary in Crocket, Texas. He wrote to the C. F. Weber [sic] Mfg. Works in April 1908 to state that the:

...cage which screws in to hold the valve stem in position in one of the intake valves of my double opposed air cooled, 10—12 H.P. gasoline motor was accidentally broken. Can you furnish the repair? The engine does not seem to have any name of maker on it. If you cannot, can you make one without the engine? The plug opposite the exhaust [sic] valve is same size and thread as the place into which this valve stem guide, or gage, screws. With this plug and other measurement I can send, can you make the repair? [sic] What will be the charge?⁶¹⁵

Weeber noted on the Smith letter that he "Ans. 4/14." Unfortunately for the reader, Weeber did not indicate whether he could fix the engine or not. A portion of a Weeber letter from June 6, 1904 addressed to the postmaster in Brenham, Texas, is in the Weeber collection at the New York State Museum. The surviving piece of the letter is typed, "Could you kindly give me the right address of Rev." Apparently, the letter was returned to Weeber. Since Brenham and Crocket are approximately only fifty miles apart, perhaps Weeber's first contact with John Smith predates the 1908 correspondence.

The grinding of valves on internal combustion engines was a frequent task undertaken by repair shops in the 1910 period. On July 9, 1909, the Weeber Works was billed \$1.00 for six boxes of "Rapid cut for grinding valves" plus \$.20 for postage by the Post & Lester Company of Hartford, Connecticut. The bill is marked paid on August 11, 1909. In January 1913, Christian Weeber ordered valve grinding compound from the Clover Manufacturing Company of New York City. Charles F. Willard of the Clover Company wrote, after receipt of the order, that "looking up our books find that we have no direct representative in your neighbor-

⁶¹⁵Smith to C. F. Weeber, Albany, N.Y., April 9, 1908. The Seminary letterhead indicates there were "Literary, Musical and Industrial Departments" in the school. Mrs. A. E. Smith was principal.

hood" and went on to ask if Weeber might wish to take on that role, enjoying "substantial discounts." Weeber answered the next day, eliciting another Willard letter.

We are in receipt of your letter of Jan. 14th, and assure you that we are very, very much surprised at the criticism you have made.

There must be some mistake either in the trial or in this particular lot of compound, for while it is used very extensively not only in this city but throughout the United States, we have never had such a complaint as this before, and assure that most all of our orders at the present time are repeat orders, many of these being as high as 2 to 5 gross.

We are sending you under separate cover one can of this compound gratis, and would like to have you give it a thorough trial before criticizing it, as we feel sure there has been a mistake somewhere in this particular case.

Would you please let us know for what purpose you use this compound, for while we have never had occasion to make a courser grade, if for some particular reason your work requires it, we would be pleased to give this matter consideration especially for you.

Feeling sure that we will receive a more favorable report if you will give this compound a careful trial, we beg to remain. . . ⁶¹⁶

Weeber marked this second Willard letter "Ans. 1/18." Unfortunately, the nature of his reply is not recorded.

An undated (by year) document on Trojan Garage letterhead in Weeber's pencil handwriting lists extensive repairs to an unidentified, possible fire damaged car. Whether these were jobs Weeber Manufacturing proposed to perform or were repairs to be made on a car for Weeber is unclear. Each of the items on the list is accompanied by a checkmark. The bottom of the list is marked by Weeber, "Sent 10/10." To suggest the extent to which repairs could be made on a vehicle, the list as transcribed by the author follows.

- Carburetor to factory as new
- 8 Valve springs
- Painting
- Reps to breather tubes

⁶¹⁶Unsigned dictated letter from "CFW" [sic] to C. F. Weeber, January 16, 1908.

- Shiall [illegible?] reps to radiator
- Full set of magneto and primary wires
- Magneto sent to factory or new one
- Brake springs . . . [illegible?]
- New Rubber mat
- Insulator thimbles through dash to Coil
- Dash board burnt to bottom but will do⁶¹⁷



Not all repair work was performed to the satisfaction of the Weeber firm or its customers. On July 12, 1910, Christian Weeber wrote to the Interurban Auto-Bus Company at Thompson's Lake:

By the removal of Car from our shop yesterday (which was not completed) we have decided to discontinue your work. Have therefore cancelled all Thomas parts on order undelivered. Within next few days will send a bill for all work done, for which kindly send check to close acct. Trusting this is satisfactory & hoping to receive check shortly we are
Yours respectfully,
CFWeeber Mfg. Wks.
Per CFWeeber⁶¹⁸

The Interurban Auto-Bus story began in 1909. In February, the *Altamont Enterprise* reported that a "new auto-bus line from Albany to Thompson's Lake is now an assured fact and buses will be running between these points by May 1st at the latest."

The Interurban Auto-bus company, Joseph W. [sic] and Joseph M. Oaks and Daniel T. Casey, directors, has been incorporated with a capital of \$15,000. The Albany terminal will be the New Kenmore, and the Thompson Lake terminal the Lakeside Inn. A regular service of 1½ hours each way will be inaugurated. The route of the new line will be through Normansville, Elsmere, Delmar, Slingerlands, New Scotland, New Salem, East Berne, Warner's lake [sic], Thompson's lake [sic] and Berne.⁶¹⁹

⁶¹⁷The Trojan Garage letterhead notes that the firm sold Locomobile and Buick cars as well as Reliance trucks. Officials were Pierce H. Russell, president; Roy V. Rhodes, treasurer and general manager; and Hugh H. McClellan, M.E., "in charge of plant."

⁶¹⁸Carbon copy of letter from C. F. Weeber to Interurban Auto-Bus, July 12, 1910.

⁶¹⁹"New Auto-Bus Line," February 12, 1909. Reprinted by the *Altamont Enterprise* in "Back in Time," February 14, 2008. The January 29, 1909, certificate of incorporation for the Interurban Auto Bus Company [sic] was signed by Joseph A.

In June of 1909, Weeber purchased a used Thomas car from the Harry S. Houpt Company in New York. The Houpt Company wrote soon after the auto was shipped that "two sets of sprockets were place in the tonneau of the car under the tires. It is strange that you have not found them."⁶²⁰ This car likely was a 1907 sixty-horsepower Thomas, because at 9:30 a.m. on July 9, Weeber "ordered by wire" a pair of brake drums for \$12 each to fit such a vehicle.⁶²¹

A Weeber invoice for the Interurban Auto-Bus Company and dated August 4, 1909, records, "One 1907 Thomas Flyer repaired new parts furnished & fitted with Bus body as per contract of #1 Thomas Bus" at a cost of \$2,400. Extras added \$92 to the total. A check for \$1,400 provided a credit leaving a balance of \$1,092 in a bill sent on August 5, 1909.

This bus body likely is that built by John Kingsbury in Albany, who billed C. F. Weeber on June 1, 1909, for work completed on May 28.

Sight Seeing Car, making to order new body with canopy top & curtains & ironing, trimming, painting & varnishing & putting on same complete with rubber matting inside & on runboards, \$450.00; making, painting, let-

Oaks of the Kenmore Hotel in Albany, Joseph M. Oaks of Thompson's Lake and Daniel T. Casey of 119 State Street in Albany. These directors held twenty, ten and ten \$100 shares each respectively in the company. Other shareholders were James A. Quinn of 119 State Street (five shares) and Charles O'Brien of the Kenmore Hotel (five shares). The amount of capital with which the corporation began business was \$10,000; the certificate does not account for the remaining \$5,000. The certificate of incorporation, in Book 14 page 50 in the Office of the Secretary of State, is stamped "Casey & Quinn Attorneys at Law." The certificate delineates three different routes between Albany and Thompson's Lake. The corporation was dissolved by proclamation on December 15, 1932. The Albany city directory for 1908-1909 lists Daniel T. Casey and James A. Quinn as partners in a law firm at 119 State Street. James A. Oaks was president of the Oaks Hotel Company at the Kenmore. Frank J. Oaks was assistant steward there. Charles A. O'Brien was bookkeeper at the hotel. There is no listing for Joseph M. Oaks. However, Joseph M. Oakes [sic] is shown as being in the hotel business in Berne, which encompassed Thompson's Lake, in the 1910 federal census. Joseph M. Oaks likely was the brother of Frank J. Oaks and the son of Joseph A. Oaks; Joseph M.'s age was 25 years in the 1910 census.

⁶²⁰F. D. Gassinger to C. F. Weeber Mfg. Works, July 8, 1909.

⁶²¹F. Crebbin of the Thomas purchasing department wrote to the Weeber Company on July 7, 1909, in response to an inquiry regarding the brake drums. Weeber noted his telegraph order on the letter. A Thomas letter from August 13, 1909, acknowledged receipt of a \$24 check.

tering & putting on signs, \$12.00; extra for leather trimming, \$28.50.⁶²²

Apparently the Interurban-Auto Bus concern was in the market for several Thomases. On May 28, Joseph A. Jones of the Thomas sales department in New York City, wrote the Weeber Works acknowledging "your esteemed favor" of the previous day. In that communiqué, Weeber had noted the purchase of the Thomas from the Houpt Company. In reply, the Thomas branch reported that it had two 1907 cars "going through our shop being put into thorough repair." Weeber was invited to have a look as these cars were, "we think, just the cars you are looking for."

On June 10, the Thomas Motor Company branch wired that they had "1907 Touring ready; \$1,320, act quick may be sold anytime." Weeber's response brought a Jones letter written the next day advising him that the car mentioned in the telegram was not one that "we have had through the shop." The sprockets and chains on this latest car were not new but "in very good condition." There was, however, a 1907 Thomas in the shop that was to be fitted with new sprockets and chains. That car would cost \$1,800. The cheaper car had a likely buyer who had had a demonstration the previous day but if Weeber wired immediately and mailed a check, the car would be held for his inspection. Weeber noted on the letter, "Called 6/16."

A month later, on August 13, 1909, the E. R. Thomas Motor Company branch in New York itself wrote Weeber offering two 1906 Thomas cars "in very fair condition" as well as two 1907 and one 1908 model, all "in good condition, and we can quote you a very good figure on them."⁶²³ It's possible that one of the 1907 models was shipped to Albany because on August 20, 1909, the Thomas branch in New York acknowledged receipt of an order for a "Model 36 Transmission Case" to be shipped from the factory. On the 23rd, the Thomas branch wrote again to say they had shipped a transmission case via American Express. They had advised the factory to send the "case ordered for

⁶²²A stamp indicates the bill was paid on September 1, 1909. A separate receipt shows that Weeber, on July 21, 1909, paid \$250 "By Cash on Account." Kingsbury's letterhead notes he was a manufacturer of "fine carriages and sleighs" as well as a repairer and painter of automobiles. His factory was at 131-133 Hudson Avenue.

⁶²³Joseph A. Jones, Sales Department, to C. F. Weeber Mfg. Co. [sic], August 13, 1909.

you [Weeber] to New York. In case you have received the case, kindly return one to us."⁶²⁴

The mobility of automobile agency employees prompted Francis [illegible?] Bowen, of the Simplex Automobile Company in New York City, to write to Christian Weeber at this point to note he, Bowen, was now associated with Simplex. What follows suggests that he recently had left the Thomas branch and knew of Weeber's search for a vehicle suitable for bus use. He mentioned that Simplex had a 40 to 50 horsepower de Dietrich seven passenger touring car for sale that was "even more powerful than the Thomas 60 H.P. and is chain driven. The de Dietrich ranks as one of the best cars built in the world." The car was available to Weeber for \$1,400 complete or for \$1,200 for the chassis alone, "assuredly the best bargain that we know of."⁶²⁵

On February 18, 1910, J. (Joseph) A. Oaks, president of the Oaks Hotel Company, wrote from the Kenmore Hotel in Albany:

I called you up several times, and was also at your office two or three times in reference to the Body of the Thomas Car bought of you. Now, I need that Body, and when I bought the Machine, of course I bought the whole thing. You told me it would cost so much, and I said "All right."

Now, you know you have enjoyed considerable business from us in the past, and did very nicely out of the two Machines you fixed over for us. The last one, I bought personally. The first one, the Company bought. There was something said about the first one. On the last one, I spent about \$50.00 for fixing over the Top, and \$25.00 for wind-shield, and I hope that you will let me have it, and am sure that you will not regret it.

Weeber noted in pencil, "3/2 wrote will let know whether next few days" as well as "write & send bill 3/18."

On April 5, J. M. Oaks, (likely Joseph A. Oaks' son), wrote on Lakeside Hotel stationery from Thompson's Lake, "Please put the touring body

⁶²⁴F. Crebbin, parts department, to C. F. Weeber, August 23, 1909. A telegram from New York on August 17 had advised the Weeber Mfg. Works, "wired factory to ship case direct to you." The author presumes the Model 36 was a 1907 and not a 1906 Thomas.

⁶²⁵The signature is the sole representation of the writer's name, which appears to be Francis Bowen. The letter was written on August 24, 1909. Weeber noted, "write 8/27 copy."

back on our Thomas car as soon as possible, according to our conversation on telephone the other day." Oaks signature noted that he was manager of the Interurban Auto Bus Company as well as of the hotel.

One more Oaks letter survives in the Weeber collection at the State Museum. On May 23, 1910, J. M. Oaks wrote from Thompson's Lake:

In reply to your letter will say that if you will order the steering gear for Matthes' [?] Thomas Car and give us prompt attention on our repair work this summer at the price quoted, we will give you considerable of our business. Bills payable monthly, if mailed weekly to me at above [Lakeside Hotel] address. Do not let the bill run three months as last season, because it requires time to check up work unless bills are rendered promptly.

Seemingly, it was at this point that relations between the Weeber and Interurban companies soured to the point that the latter removed their vehicle from the former's premises.

Another customer with complaints was Frederic W. Tietz, Jr., a musical instrument maker and dealer in Albany. Along with a check "in full settlement to date," Tietz wrote the following:

When I sent the Auto up to have the Radiator repaired I also left word with your Book Keeper to have your man stop the Oil from leaking out of front and running all over the front Tire also to stop Oil from throwing out of hind Wheel but it seems it is just the same as ever.

You will remember you promised to do this for me with out charge at some time when you were not busy as the Car was always throwing Oil.

Kindly let me Know [sic] when it will be convenient for you to straighten my Car out and oblige...

P.S. You also promised me a Tire Tools which I forgot to speak about.⁶²⁶

In early 1908, A. Bolduc of New Bedford, Massachusetts, wrote to Weeber that he, Bolduc, had

⁶²⁶Frederic W. Tietz to C. F. Weeber, June 14, 1909. Weeber noted on the letter, "Any[?] Attention" and "6/18 Copy."

received a statement noting a \$10 charge. Bolduc continued, "I wish you would send me a bill for this acct as I dont [sic] remember buying any thing from you and I have look [sic] all my bills and I dont [sic] see any bill for it." Bolduc signed his letter, "A Bolduc North End Garage Successor to North End Garage Co."

Weeber responded by letter eliciting a second note from Bolduc. In his second message, Bolduc explained that the North End Garage Company didn't exist any longer, since he had "bought them out but I see that you will get your money as I know who got the goods and it was one of the members of the company the Garage will run on the name of Bolduc Garage."⁶²⁷

Perhaps letters incorporating complaints that were preserved because those messages required reaction and action on the part of the Weeber Manufacturing Works. James Love, an Albany hatter, wrote in September 1908, enclosing a check for \$18.34 to settle a bill. In a postscript he added, "The Cut Out you put in my car was a miserable failure."⁶²⁸

A customer with a different problem was V. E. Consalus, treasurer of the Geyser Spring Company in Saratoga Springs. In response to a Weeber letter, Consalus wrote in June 1910, "I personally returned one coil unit for credit. The Bookeeper [sic] was out & I left the coil on the show case together with a note also explained it to one of the boys in the shop. I think if you call their attention they will remember it." The next day Weeber wrote, "We are in receipt of yours of the 28th inst in reference to Coil Unit. We have taken the matter up with the man in shop that waited on you when you were here and he claims you did not return anything but said you spoke of returning one. . . Kindly look further in the matter and let us know as we want the matter settle up right." Weeber wrote on Consalus' letter, "Ans. 6/29/10," notations that he scratched out as well as "wrote 9/13 explaining de-

⁶²⁷A. Bolduc to C. F. Weeber February 3, 1908 and March 5, 1908. Bolduc's letterhead shows him to be a plumber, tinsmith and hot air furnace fitter at 924 Acushnet Street in New Bedford. The 1923 New Bedford directory lists Azarie Bolduc as a plumber at 126 Perry Street. In 1908 Bolduc wrote that his North End Garage was at 117 Bowditch Street.

⁶²⁸James Love to C.F. Weeber, September 21, 1908.

lay & told you [?] deduct what we know [?] was right, Copy."⁶²⁹



The C. F. Weeber Manufacturing Works sublet automotive body work. The same John Kingsbury bill for the sightseeing body stated a \$1 March 23, 1909, charge for "repairing, glueing [sic] & nailing up moldings ect [sic]" on "Shaws Ford" as well as \$35 March 31 charge for "taking apart, cleaning, [sic] repainting, stripeing, [sic] & varnishing body and chassis complete, scraping & refinishing widow frames & putting all together & in order" on the same vehicle.⁶³⁰

A Weeber account with John Kingsbury produced a statement of charges on January 1, 1911, extending back one year to the cost of the sightseeing body. Additional work in 1909 included putting fenders on Dr. Shaw's car (\$6 on April 8); adding hardware and lights (windows) to the top of a Haynes (\$.85 on May 13 and \$4.45 on May 27); repainting Mr. Dookheim's Ford runabout in gray and adding an enamel duck to a box (\$25 and \$1.50 respectively on June 7); painting a Ford runabout in green (\$20 on June 20); painting and varnishing a fender on a Haynes (\$2.50 on June 22); making a new top cover to order for Dr. Hart's car (\$10 on June 22); painting and varnishing as well as installing a new fender on Dr. Shaw's car (\$2 and \$1 respectively on September 2); cleaning and dressing the leather on a "Black Touring Car" (\$2.50 on September 8); cleaning the trimming probably on the same car (\$1.80 on September 26); and re-trimming a Ford touring car (\$14.40 discounted 10% on November 8). The total charges were \$569.06 against which there was a "special deduction" of \$50 and credits of \$10.80, \$150 and \$129.50 on June 7, June 30 and September 7 respectively. The outstanding amount was \$228.76.

Notations on the statement in Christian Weeber's hand record, "1/6 By Check" as well as "Pd. 3/6/11 CFW." The amounts paid on each of those

⁶²⁹Consalus to C. F. Weeber Mfg. Works, June 28, 1910; C. F. Weeber Mfg. Works to V. E. Consalus, June 29, 1910. The Weeber letter is a typed copy, one of the few surviving in the Weeber collection at the New York State Museum.

⁶³⁰A \$40 cost is noted at the conclusion of the description although Weeber was charged only \$35. Perhaps the \$5 difference was intended to allow Weeber a mark up for that amount.

two dates are unclear but it's likely the last remittance was \$150.

In June 1909, John J. Maas, a "manufacturer, carpenter and builder" at 239 Sherman Street, billed Christian Weeber for charges in May and June including, "1 hour machine work at dash board" (\$.70); five feet of white wood (\$.40); two feet of birch (\$.20); fourteen feet of oak (\$1.12); and "½ hour machine work at oak" (\$1.12). The total charge of \$2.77 was decreased by \$.95 "By your bill." The author assumes all Maas' work was automotive, although conceivably some might have been done for the Weeber facility on Central Avenue. The house on Manning Boulevard was not yet under construction.

In 1910 and 1911, Weeber contracted with Knox & Schaible, on Spruce Street in Albany, for painting and trim work. Charges for painting included \$40 on December 27, 1910; \$22.50 the same day; and \$30 on January 19, 1911. Other charges made a total of \$100 billed on March 1, 1911. Christian Weeber noted that \$50 was paid by "check & counter acct." A second Knox & Schaible bill on March 24, 1911, listed the \$50 due plus \$40 for painting Mr. McCabe's auto and \$2.75 for "new cel [Celluloid?] sheet & sewing in curtain."

In the spring of 1909, the Willoughby Company in Utica, manufacturers of carriages, sleighs and automobiles bodies, wrote to the Weeber firm to ask if there might be an interest in "Limousines and Landaulets for the fall and winter trade." Bodies could be provided in wood or aluminum "from your design or ours."⁶³¹ It's unlikely that Weeber, who noted his reading of the letter with a penciled oval, ever purchased a Willoughby body but the retention of the letter suggests that such a purchase was considered a possibility.

In January 1908, the Weeber Manufacturing Works received a letter from L. Sonneborn Sons, Inc. in New York, promoting "protective enamel for all metals, wood and concrete." The Weeber firm was invited to ask for a sample. Weeber duly requested a sample in white but a second Sonneborn letter informed him that the paint came "in black only." Weeber wrote again and a sample was sent. Sonneborn followed up three months later to ask if the "tests made with same sample met with your requirements, and if we may expect your

⁶³¹E. A. Willoughby, president, to C. F. Weeber Mfg. Works, May 27, 1909.

CUSTOMERS VEHICLES NOT INSURED UNDER OUR POLICIES

JACOB S. KINGSBURY
ALBANY, N. Y., Jan. 1, 1911.

Mr. C. F. Weeber,

AUTOMOBILES TO JOHN KINGSBURY, DR.

REPAIRED AND REPAINTED
 WE MAKE TO ORDER
 TOPS,
 SLIP-LININGS,
 LUGGAGE CARRIERS,
 ETC.

MANUFACTURER OF
**FINE CARRIAGES AND SLEIGHS
 AND AUTOMOBILE BODIES**
 ALBANY, N. Y.

FACTORY:
 131-133 HUDSON AVE.
 AND
 7-9-11 JAY ST.
 OFFICE:
 133 HUDSON AVE.

ALL WORK UNDER MY OWN SUPERVISION AND WARRANTED

Dec. 31/09	New sight-seeing body built to order with top and curtains complete on car	450 00
	Extra for leather	28 50
Apr. 8	(Dr. Shaw) Putting on fenders, making iron New fender bolts	6 00
May 13	Haynes,- Putting in 4 brass screw studs, 4 brass snaps	40
	1 buckle on 2" strap	25
	1 strap 24" long	20
	27 2 lights in front curtain	
	1 light in back curtain	
	7 eyelets	4 45
June 7	Ford Runabout,- Repainting (gray)	25.00
	(Bookheim,- Putting enamel duck top on box	1 50
June 20	Ford Runabout,- Repainting (green)	20 00
June 25	Haynes,- Painting and varnishing new fender	2 50
June 22	(Dr. Hart) New top cover made to order	10 00
Sept 2	(Dr. Shaw) Painting and varnishing new fender	2 00
	Putting on new fender	1 00
8	Black Touring Car,- Cleaning and dressing leather	2 50
26	Cleaning trimming	1 80
Nov. 8	Ford Touring Car,- Retrimming car	14.40
		10%
		12 96
		569 06
June 7	Special Deduction	50.00
" 30	Credit	10.80
Sept 7	"	150.00
	"	129.50
		340 30
		228 76
		2876
		200 00
		58 00
		150 00

1/6 By Check

pd 3/6/11

Figure 6.8: John Kingsbury bill with Christian Weeber's penciled notations, January 1, 1911. NYSM Collection, H-2000.39.NN.

valued orders....” The last surviving Sonneborn letter states, “regret very much to note that the sample of our AMALIE PROTECTIVE ENAMEL forwarded to you does not meet with your requirements.” Nevertheless, Sonneborn was sending a copy of their catalogue and in the letter mentioned the prices on some of their other products: Amalie Guaranteed Non Carbon Oil (“used by the leading garages throughout the United States”) at \$.30 a gallon in original barrels FOB New York; Amalie Automobile Soap at \$.04 per pound; and Amalie Gear Case Oil at \$.30 a gallon.⁶³² Whether Weeber purchased any Sonneborn products is unknown here. A year later, the Weeber Works received two letters from the Pecora Paint Company in Philadelphia, Pennsylvania, promoting Pecora Machinery Paints.⁶³³

Weeber did buy “Special Heat Resisting Liquid” in a gallon can along with “Gloria Aluminum bronze” in a one pound can from the Baer Brothers in New York City in 1907. He also purchased two gallons of gilt edge metal polish from W. H. Cross in Brooklyn, the order “sent with Weeber Cycle Works” at 147 Central Avenue, indicating a cooperative business arrangement between Weeber brothers. An order from wholesale druggists Walker & Gibson in Albany for one dozen half-pint containers of Hopkins Star Polish, along with three quarts of the same product, indicates that Weeber purchased for resale.⁶³⁴ Five gallon purchases of wood alcohol from Walker & Gibson on December 6, 10 and 15, 1910, as well as on January 31, 1911

⁶³²A. Solomon [illegible?] for L. Sonneborn Sons, Inc. to C. F. Weeber [sic] Mfg. Works, to C. F. Weeber Mfg. Works, January 17, 1908; January 20, 1908; Julius Rabin for L. Sonneborn Sons, Inc., to C. F. Weeber Mfg. Co., April 15, 1908; April 22, 1908. The Sonneborn letterhead indicates the company represented the German firm of Oilworks, Stern-Sonneborn A.G.

⁶³³Both letters to the C. F. Weeber Mfg. Wks., April 6 and April 21, 1910, are signed “S Bowen’s Son.” The letterhead notes the principal in the Pecora Paint Company was S. B. Bowen.

⁶³⁴The Baer Brothers bill is dated February 9, 1907, and was marked paid on March 23. The total cost was \$2.25. The W. H. Cross bill for \$1.80 is dated April 9, 1907, and was paid on June 11, 1907. The Walker & Gibson bill is dated October 21 1907, and was paid on December 5. The price notations are confusing. The half pints may have cost \$.125 each and the quarts \$1.25. Those figures do not seem logical, i.e., the cost of purchasing the larger quantity would thus have been more expensive per fluid unit than the purchase of the smaller quantity. A final notation indicates a total charge of \$2.75.

and February 21, 1911, at \$.60 a gallon probably was for use as a general solvent.

The extent of the Weeber automobile repair business in the post-1920 period is not well documented in the materials preserved at the New York State Museum. That such repairs were undertaken is suggested by a few documents, such as a 1925 Detroit Steel Products Company list of leaf spring applications for cars and trucks. This booklet is rubber stamped with the name and address of the Shippey Spring Service Station at 376 Central Avenue, where “springs [were] installed and repaired.”⁶³⁵ There is also a 1928 edition of the Ambler Autobestos catalogue of brake linings and clutch facings. This item printed with the name of the local dealer, the Peerless Auto Parts Company at 261-263 Central Avenue.⁶³⁶

⁶³⁵H-1933.6.235. Penciled price calculations on the covers do not appear to be in Christian Weeber’s hand.

⁶³⁶H-1933.6.202. The Peerless warehouse was at 250 Sherman Street, across from the earlier Weeber Mfg. Works site. The Ambler products were made by the Keasbey & Mattison Company of Ambler, Pennsylvania.

CHAPTER 7. AGENT FOR THE MAXWELL-BRISCOE MOTOR COMPANY OF TARRYTOWN, NEW YORK AND THE CORBIN MOTOR VEHICLE CORPORATION OF NEW BRITAIN, CONNECTICUT

1906-1907

By August 1906, Christian Weeber owned a Maxwell car. He was involved in the activities of the Central Automobile Company, which, in 1906, became a Maxwell agency at the same Central Avenue address as the C. F. Weeber Manufacturing Works. His partner in the Central operation was Willard J. Sutherland, Sr., once principally in the produce business. Sutherland probably was a somewhat passive player in the operations of the Central Automobile Company, while his son, Harry L. Sutherland, likely was more active in the automobile operation.

By September 1906, Christian Weeber, sometimes identified as Charles Weeber, as part of the Central Automobile Company, also was selling Fords (the history of his relationship with the Ford Motor Company is delineated below). In 1906, *The Albany Argus* reported that of the approximately 250 cars owned by Albanians, the leading makes were Maxwell, Locomobile, Peerless, Thomas and Ford.⁶³⁷ Given that both the Ford and Maxwell lines had relatively inexpensive models and somewhat more expensive cars, one might credit Weeber and Willard Sutherland with foresight securing agencies with the greatest sales potential.

In September 1906, Harry Sutherland also had a Maxwell. "Mr. Henry Sutherland left last week in a Maxwell car for a tour through Schuylerville, Greenwich, and as far north as Lake George." A month later, Sutherland returned from a "success-

ful trip" to Schuylerville and planned "a flying trip in a Maxwell Touring Car to the Maxwell-Briscoe Company's factory in Tarrytown."

The date at which the Central Company operation began selling Maxwells may be simultaneous with Ford sales but cannot be pinpointed here. Telephone records suggest early summer as a possibility. Certainly by early November 1906, the Maxwell agency operation was in full swing. That was when *The Argus* reported that, "The Central Automobile Company, which has the agency for this territory of the Maxwell car, has established a sub-agency in Troy."⁶³⁸ While the details of that Troy operation have not been uncovered here, the reader might note that in the spring of 1906 the newly established Schenectady Automobile Exchange, at 18 Lafayette Street, likely not affiliated with the Central Automobile Company, was selling Mitchell and Maxwell cars.⁶³⁹

In the fall of 1906, a Maxwell Model H reportedly established a world record of 3,000 miles in

⁶³⁷*The Argus*, September 2, 1906, September 9, 1906 and September 23, 1906. Car registrations for the first six months of 1905 in New York State showed Ford in sixth place (221 cars) and Maxwell in thirteenth (99 cars) among gasoline-fueled autos. First was Cadillac with 444 registrations. *The Horseless Age*, August 2, 1905, vol. 18, no. 5, abstracting a report in the *New York Herald*.

⁶³⁸November 11, 1906. The identification of the Troy sub-agent for the Central Automobile Company has not been revealed after a quick check of the *Troy Record* (November 1-12, 1906) and an even shorter scan of the *Troy Daily Press*, the latter unfortunately in out-of-focus microform. In October 1910, the Trojan Maxwell dealers were Burdick & Hartwell (John Burdick and Harold G. Hartwell). Neither Burdick nor Hartwell are listed in the automobile business in the (July 1) 1907 Troy directory. The 1908 directory (July 1, 1908) shows John Burdick in the automobile trade at 35 First Street, while Hartwell was a bookkeeper in the Hall, Hartwell & Company shirt business. For 1909 Burdick had moved to 192 River Street; whether he was a Maxwell agent then or the year before is not indicated. For 1909 Hartwell remained with the shirt company. In 1913, the Ilium Garage (George S. Bord and James N. Bussey), selling Maxwell and RCH, had replaced Burdick & Hartwell, both still individually in the auto business.

⁶³⁹For an announcement of the Schenectady Automobile Exchange organization see *The Horseless Age*, vol. 17, no. 20, May 16, 1906.



Figure 7.1: Photographs of Willard J. Sutherland (bottom row, center) and Christian Weeber (3rd row, second from right) in Albany Automobile Dealers' Association photograph, 1921. H-1970.110.51.

seven days, seven hours and thirty minutes. In the process, "daily bulletins were received by the Central Automobile Company."⁶⁴⁰

Among likely Central Automobile Company customers was a John J. Kennedy who, driving a 16-20 horsepower Maxwell, took advantage of fine weather and made "daily runs out toward Clarksville" in early November 1906.⁶⁴¹ A few weeks earlier, Walter L. Palmer, still at his summer home in Selkirk, "drove up to Albany several times last week in his Maxwell Runabout."⁶⁴² Another local Maxwell operator was Mrs. Howard Martin, who drove a "'Doctor' Maxwell" and had "taken many short trips in and about the city in the past two weeks."⁶⁴³ Fletcher W. Battershall and his wife, Maude F. Battershall, "who went to Portland, Maine, in their Maxwell Runabout... returned after a six weeks visit at this summer resort."⁶⁴⁴ *The Argus* noted the following April that after the winter, Battershall "is again driving his Maxwell Runabout."⁶⁴⁵ In June 1907, "Mr. McCormick, Mr. C. A. Stuart, Mr. McHugh and Mr. C. A. Wilson" drove a two-cylinder Maxwell to Lakeside, a new hotel at Thompson's Lake.⁶⁴⁶ Christian Weeber, along with C. [Chauncey] D. Hakes and Frank B. Graves, "took a spin to Thompson's lake, Sunday [August 11, 1907]."⁶⁴⁷ As shown elsewhere in this work, in 1909 and 1910 Christian Weeber was involved in business transactions with the owner of the hotel.

Surviving Hudson River Telephone Company toll records document calls from Weeber's West

⁶⁴⁰*The Argus*, November 11, 1906. Ending on October 31, reportedly "in the history of the world this is the greatest distance ever traveled by any self-propelled vehicle." Expenses for the run totaled only \$49.50.

⁶⁴¹*The Argus*, November 11, 1906. The Albany city directory for 1906 lists two men named John J. Kennedy. One, a bottler, boarded at 17 Judson Street. The other, an inspector for the Home Telephone Company and perhaps the likely automobilist, boarded at 159 Hudson Avenue. A year later, both men remained in Albany but in new boarding houses.

⁶⁴²*The Argus*, September 23, 1906.

⁶⁴³*The Argus*, October 14, 1906. The "doctor" reference was to a Maxwell Runabout reportedly chosen by many physicians for use in their professional travel. The paper, on September 2, 1906, had observed that Mrs. Martin's Maxwell "is as complicated to manage as a larger car which is ordinarily driven by a man."

⁶⁴⁴*The Argus*, September 23, 1906. Battershall's second novel, *Mists* (1894), is set at a Maine resort.

⁶⁴⁵April 7, 1907.

⁶⁴⁶*The Argus*, June 2, 1907.

⁶⁴⁷*Albany Evening Journal* August 14, 1907.

460 number to the Maxwell-Briscoe Motor Company in Tarrytown on July 6, 1906 (with a pencil notation of "Central Auto Co"); on August 1, 29 and 30, 1906; probably on September 14, 1906 (to "360 Downer" but otherwise not identified as the Maxwell telephone) and on September 18, 19 and 28, 1906; on October 23, 1906; and on November 21, 1906. An October 31, 1906, call to the "Repair Dept." in Tarrytown suggests Weeber was involved with the maintenance of a Maxwell car.

The next year, calls to the Maxwell-Briscoe Motor Company occurred on April 29, July 29 and September 16. On April 20, 1907, a party named "Dorman" was telephoned in Tarrytown. On August 5, "Jas. Kater" telephoned "Burns" in Tarrytown and on August 6, Kater called "Turner" in Tarrytown. On August 21, Weeber's telephone reached "Towner" in Tarrytown. Confirming Harry Sutherland's involvement with Weeber, the latter's telephone bills show the former called Towner on September 7, 1907.⁶⁴⁸

A check of the *Hudson River Directory* for 1908-1909 shows that Frank A. Dorman was secretary of the Maxwell-Briscoe Motor Company. Perhaps it was he whom Weeber contacted in April 1907 or perhaps it was Sherman W. Dorman, a clerk. Both Dormans resided at the same Tarrytown address.

In March 1907, Theodore W. Van Hoesen bought a Maxwell from the Central Automobile Company. The following month, new Maxwell customers were MacNaughton Thompson and Henry T. Martin, who bought Runabouts; Dr. W. H. George, "of the Central Automobile Company, [who] bought a new Maxwell Runabout on Friday [April 12], of the Central Automobile Company";⁶⁴⁹ George E. Thompson, who bought a Runabout from Central; and William Trumbley of Rensselaer, who bought a Model R. L. Runabout. The Central Automobile Company had "its warerooms filled with exhibition cars of the two firms it represents," including R.L., R.M. and H.B. Maxwells and Model M [sic] Fords.⁶⁵⁰ Fletcher Battershall, Christian Wee-

⁶⁴⁸The *Hudson River Directory* editions for 1906 through 1908 list several people named "Burns" and "Turner." Among them are Solomon Burns, a machinist residing in Tarrytown (1906); John E. Burns, a manager residing in Tarrytown (1908); and Joseph S. Turner, a machinist living in North Tarrytown (1908). Whether any of these men was employed by the Maxwell-Briscoe firm is unknown here.

⁶⁴⁹*The Argus*, April 14, 1907.

⁶⁵⁰*The Argus*, April 21, 1907. It's likely the newspaper had the Model N Ford in mind.

ber's collaborator in the shock absorber affair, was "again driving his Maxwell Runabout."⁶⁵¹



In April 1907, with the Central Automobile Company selling both makes, *The Argus* noted that Harry Sutherland "is driving almost every day in order to demonstrate the possibilities of the Maxwell & Ford cars which are the particular makes sold at the Central Avenue Garage."⁶⁵² But at some point in 1907, certainly before October 3, the business relationship between Christian Weeber and the Sutherlands ended. The Central Automobile Company relocated to 130 Quail Street as the Maxwell agency. Christian Weeber continued to sell Fords at 170-172 Central Avenue. In the late winter of 1908, the Central Automobile Company used display advertisements to announce their "New Show Rooms" were open at 130-132 Quail Street and the 1908 Maxwell models were on display. The Central Company was "Distributors for Albany, Rensselaer and Schoharie Counties" with "Agents Wanted in Unoccupied Territory."⁶⁵³

In April 1908, Christian Weeber wrote to the Bosch Magneto Company in New York seeking a Bosch magneto for "a 4-cylinder Maxwell Runabout." The Bosch Company replied, noting the \$115 list price in a reply, stated that the Weeber firm would be allowed a 20% discount "and if within 12 months your purchases reach 10 magnetos, we will refund an additional % [percent]..." There also was a 2% reduction for prepayment. On the letter, Weeber penciled, "Wrote about delivery 4/22."⁶⁵⁴

In March 1909 *The Argus* noted that the Central Company represented "the Maxwell and the Knox machines."⁶⁵⁵ Central continued to advertise its Maxwell line. The newspapers noted the sale of

Maxwell cars to local customers.⁶⁵⁶ But soon there was a "Maxwell Auto Company" doing business in Albany, an agency which, "on account of their increase in business,... leased the large three story building at No. 72 Central Avenue" for occupancy "on or about September 1 [1909]".⁶⁵⁷ For the 1910 season, the Central Automobile Company was selling Knox and Hupmobile but not Maxwell cars.⁶⁵⁸ For 1911, as recounted below, the Central Automobile Company replaced the C. F. Weeber Manufacturing Works as a distributing agency for Ford automobiles. In addition, the Central Company sold 1911 Knox and Paterson machines.⁶⁵⁹

By 1910 the Tarrytown-based Maxwell-Briscoe Company, if it hadn't assumed sole sales responsibility directly in the Albany area through a subsidiary, had, at a minimum, channeled Maxwell operations to the new Maxwell facility on lower Central Avenue. The new Maxwell-Briscoe Albany Company was an exhibitor at the 1910 Albany Auto Show. Walter K. Hadley, manager at the 72-74 Central Avenue operation east of the Weeber business, was in charge. Columbia Cars were also at the show, displayed by the Maxwell firm. That was understandable since both Maxwell and Columbia had become part of the United States Motor Company. By October 1911, the Maxwell dealer was the United Motor Albany Company, at 44 State Street, with Hadley as manager.⁶⁶⁰ Whether this com-

⁶⁵⁶*The Argus*, March 7, 1909, has a large Central display advertisement. The paper also notes the sale of Maxwells to H. R. Wright of Albany, A. J. Peets of Watervliet and Dr. Fisher M. Joslin of Voorheesville.

⁶⁵⁷*The Argus*, August 22, 1909. The *Times Union*, however, for October 4, 1909, said the Central Automobile Company was "agent for two of the most popular and dependable cars on the market, the 'Knox' and the 'Maxwell'..."

⁶⁵⁸*Albany Times Union*, March 5, 1910. The company, however, is identified as the "Central Auto Exchange" at 130 Quail Street. Perhaps the Hupmobile was a late addition for the 1910 model year. *The Argus* for March 6, 1910, only mentions the Knox line at the Central Automobile Company. Display advertisements on March 13 and March 20, 1910, only had information about the \$3250 Knox Model R.

⁶⁵⁹*The Argus*, February 19, 1911. Central had three Knox cars, one Paterson and three Fords at the 1911 Albany Auto Show.

⁶⁶⁰The *Times Union* for March 5, 1910, notes that six Maxwells and two Columbias would be displayed at the first annual Albany Auto Show. The newspaper also described the recently organized United States Motor Company. Hadley first appears in the Albany city directory for 1910. Towards the end of the auto show, Hadley said he had sold sixteen cars there already. See the *Sunday Press* for March 13, 1910. One wonders if the Weeber firm had sold that many cars during

⁶⁵¹*The Argus*, April 7, 1907.

⁶⁵²April 28, 1907. The newspaper also reported that Sutherland had "returned from a visit to the Maxwell factories in Tarrytown."

⁶⁵³*The Argus*, March 15, 1908. See also March 24, 1908, for a different display advertisement.

⁶⁵⁴"Keins," vice-president, to C. F. Weeber Mfg. Works, April 20, 1908.

⁶⁵⁵March 28, 1909. The paper reported January 17, 1909, that the Central Company had "taken the agency for the Knox Water Cooled Pleasure and Commercial cars." A \$2,950 Model O was on display then at 130 Quail Street.

pany or the Maxwell-Briscoe Albany Company or both actually were parts of the United States Motor Company or merely affiliated agencies is unknown here.

As postscript to Christian Weeber's involvement with the Central Automobile Company and Maxwell automobiles, it might be noted that an advertisement in the September 9, 1909, *Albany Times Union* announced a Maxwell Runabout in "fine running order" was for sale "cheap to a quick buyer." Interested parties were to write to Box 26 in Valatie. A letter written by W. J. Empie in Seward on September 10 to Box 26 asked about the car, its condition and "very lowest price." Christian Weeber noted on the letter "write" and someone, perhaps he, "wrote 9/21." The connection between the post office box in Valatie and Christian Weeber remains a mystery here. Perhaps in 1909, while he was still a Ford agent in Albany, he had a sub-agent in Valatie.

Perhaps the Central Automobile Company was a Corbin agency when Christian Weeber was associated with the firm in 1906. Whether a contracted agent or not, the Central concern sold a Corbin to Christian's brother, Emil. In September 1906, *The Argus* noted that, "Mr. Emil Weeber, who purchased a Corbin Touring Car of the Central Automobile Company, is making a tour through the east with Mrs. Weeber and Mr. and Mrs. Walter Van Wely."⁶⁶¹ In 1910, a list of cars, encompassing vehicles that Christian Weeber wished to sell, includes a 1906 Corbin Touring Car. On that list, a value of \$500-\$450 is attached to the car. In 1906 the Corbin factory prices was \$2,000. Whether the

Central operation sold any Corbin cars other than that to Emil Weeber is unknown here.⁶⁶²

the show. In the 1911 city directory Hadley is reported to have "moved from city" leading one to wonder if he might have been a Maxwell-Briscoe employee who came to Albany to run a factory dealership. Display advertisements for United Motors appear in *The Argus*, October 20, 1910 and February 19, 1911. The company also sold Columbia autos and Sampson trucks. *The Argus* for August 28, 1910, reported that the Maxwell-Briscoe Company with Hadley in charge was "making a quick recoup from the setback occasioned by the burning of the Lark Street quarters of the Albany agency..."

⁶⁶¹September 26, 1906. The story concluded, "Pittsfield, Lenox, Stockbridge and some of the other prominent summer resorts have been visited." The paper on October 2 had reported that the two couples, who had been making a tour of the Berkshires in Emil Weeber's Corbin, "have returned to the city." In this period, Corbins were known for air-cooling of the engines. Christian Weeber's surviving car also is air-cooled.

⁶⁶²



Figure 7.2: Photograph of Weeber family in a Maxwell touring car, probably a Model H of 1906 or HB of 1907, Quail Street and Western Avenue in Albany in 1906. From left to right: Christian Weeber, Hertha Weeber (Christian's sister), Dorothy Weeber (Christian's niece, the daughter of his brother Edward and wife Emma), Marion Weeber and Pauline Weeber. For reference, the reader might keep in mind that Marion was born on September 5, 1905 and Dorothy in 1899. NYSM Collection, H-1987.39.6.



Figure 7.3: Photograph of Weeber family in a Maxwell car, c. 1907. This second photo may show the same car but likelier a different one fitted with an extension top, headlamps, ornate lettering on the radiator and perhaps different color wheels. Marion Weeber labeled the view, "Driving in the Country About 1908." Posing were Christian Weeber, Marion at the wheel, Pauline, Hertha and Christian's mother, Dorothea. If Christian Weeber's involvement with Maxwell cars ended in 1907, then that is another argument for dating this photo from that year rather than the next when, apparently, Weeber was a Ford agent exclusively. New York State Museum Collection, H-1987.39.7.

CHAPTER 8. AGENT FOR THE FORD MOTOR COMPANY OF DETROIT, MICHIGAN

1906 - 1908 Model Years

While the Ford Motor Company in Detroit, Michigan, would find unparalleled success with the Model T introduced in 1908, by 1906 the enterprise already was among the more successful builders in the United States. The Fords available just before the T included the two-cylinder F (through 1906); low-cost, four-cylinder N, R and S models; and the expensive (\$2,800) six-cylinder Model K.⁶⁶³

By 1906, Christian Weeber was in a partnership arrangement with Willard J. Sutherland, selling Ford and Maxwell cars. In August, *The Argus* reported that the “first Ford runabout [Model N] has arrived, and that the long awaited for car is a success in every particular.” The new six-cylinder Model K also was deemed a pronounced success” by the newspaper, although nothing was said about its arrival in Albany.⁶⁶⁴

In mid-September 1906, Henry M. Sage, Charles L. A. Whitney, Archland Dederick and Charles H. Sabin, “who have ordered Ford runabouts expect to have them reach the city this week.”⁶⁶⁵ Francis

⁶⁶³An undated Model N parts price list is part of the Weeber collection at the New York State Museum, H-1933.6.298. A Ford advertisement in *The Motor Way* for December 14, 1905 (p. 38), notes that deliveries of the new “Models N & K will not be made before March” 1906. Small print claimed “1906 will be a ‘Ford Year.’ Agents who have closed with us can congratulate themselves.”

⁶⁶⁴August 19, 1906. *The Horseless Age*, July 11, 1906, vol. 18, no. 2, has an extensive description of the Model N supplemented with an explanation of the car’s high quality and low price based on automatic production machinery, interchangeable parts and volume all “putting the automobile in the same class with typewriters, sewing machines, guns and other interchangeable products.”

⁶⁶⁵*The Argus*, September 16, 1906. Elsewhere in the same issue, *The Argus* noted that H. M. Sage, Charles L. A. Whitney, Archland Dederick and Charles H. Sabin, as well as P. K. Dederick, E. B. Cantine and Louis F. Greenleaf, all were automobile owners in the summer colony at Loudonville. Coincidentally, in 1906 Whitney also purchased from the Weeber family the farm where Christian Weeber grew up. On September 9, 1906, *The Argus* reported that the Ford Motor Company had sold cars to G. A. Hubbard, Francis B. Harrington, Jr., Charles



Figure 8.1: Photograph of Model N Ford in front of 168 Central Avenue. A portion of the Weeber Manufacturing Works (and, depending upon the date this photo was taken, of the Central Automobile Company) showroom appears on the viewer’s right. NYSM Collection, H-2000.39.105.

B. Harrington had "his new 17½ H.P. Ford runabout" by the end of September and was "making short trips about Albany with splendid time records."⁶⁶⁶

By mid-October, Whitney had taken delivery of the Ford runabout "ordered several weeks ago through the C. M. [sic] Weeber agency" and a "car load of Ford runabouts" had been shipped "from the factory to supply orders given by Mr. C. M. [sic] Weeber." The buyers for the "small cars" were Dederick, Peter Gansevoort Ten Eyck and Colonel Selden E. Marvin, all of Albany as well as Dr. A. C. Abrahams of Newtonville. At mid-month, these men "received their Ford runabouts, ordered through the Central Automobile Company [sic]. The machines arrived on Wednesday."⁶⁶⁷ "Dr. Abrahams of Newtonville, who purchased a Ford runabout through the Central Automobile Company, [was]... meeting with every success in the use of his new machine." Other Dederick family Ford motorists were P. K. Dederick and Mrs. Archland Dederick, who had been driving an Oldsmobile during the summer of 1906.⁶⁶⁸

The Argus claimed the Ford Model N was a sensation as a hill climber. "The car is rated at 15 horsepower but the motor shows over 18. The weight of the car is just 1,000 pounds and in this relation between power and weight is the secret of its success on heavy grades." F. A. [sic] Harrington, on the other hand, "has a six-cylinder Ford machine from New York on trial."⁶⁶⁹ Perhaps Harrington obtained the car from the Ford Motor Company branch in New York City. Another local owner of a six-cylinder Ford was Philip Barzen, a Second Street saloon keeper who, with his wife and John

Renny, had "been making extensive tours" by early September 1906.⁶⁷⁰

For October 21, 1906, *The Argus*, announced that:

The management of the Central Automobile Company, which is composed of Mr. W. J. Sutherland and Mr. C. W. Weeber, will be Albany agents for both the Maxwell and Ford machines, and during the winter months will have on exhibition the 1907 models from these manufactories.⁶⁵³

In early 1907, Albanian Ford buyers included John Gordon, who by the end of March had "purchased a Ford Runabout of the Central Automobile Company" even as experienced Ford owners took to the roads following a winter layoff, e.g., "Colonel... Marvin... now making daily trips in his Ford Runabout"⁶⁷¹ and Mrs. Archland Dederick, "who owns a Ford Runabout... driving again."⁶⁷²

The earliest surviving correspondence between Christian Weeber and the Ford Motor Company dates from October 1907, probably after the separation of the Central Automobile Company and the C. F. Weeber Manufacturing Works, i.e. the severing of the business arrangement between Christian Weeber and Willard Sutherland. It was then that R. S. Andrews wrote from Detroit that the manufacturer would replace a broken Model S spring although the spring looked "as though it had been broken on account of having been overloaded." Weeber was advised to notify the Ford Company in the future for advice about whether a part would be replaced gratis. A note at the bottom of Andrews' letter noted that as of the day on which he wrote, there were 9,672 Models N and R runabouts on the road.⁶⁷³

At the end of October, the Detroit factory wrote that the new Model S cars were out of stock but a shipment was expected within a day. In fact, an invoice dated October 31 lists a Model S with serial number 452 for Weeber. The base price of \$700 was increased \$50 for a top. Incidental expenses, such as oil, gasoline and shipping, brought the total to \$771.80. However, Weeber enjoyed a 15% discount on the price of the car, plus 20% and 25%

⁶⁷⁰*The Argus*, September 2, 1906. Philip J. Barzen is listed at 332 Second Street in both the 1906 and 1907 directories. There is no listing for Renny.

⁶⁷¹*The Argus*, March 31, 1907.

⁶⁷²*The Argus*, March 24, 1907.

⁶⁷³Andrews to Weeber, October 17, 1907.

H. Sabin, C. L. A. Whitney, Archland Dederick, Henry M. Sage and Philip Brazen [sic] all of Albany. The last probably was Philip J. Barzen.

⁶⁶⁶*The Argus*, September 26, 1906.

⁶⁶⁷*The Argus*, October 21, 1906. "Wednesday" was October 17, 1906.

⁶⁶⁸*The Argus*, September 2, 1906 and November 4, 1906. "... many of the most enjoyable trips taken by Mr. P. K. Dederick is [sic] in his Ford auto." "P. K." refers either to Peter K. Dederick or Preston K. Dederick.

⁶⁶⁹*The Argus*, October 14, 1906. On September 16, 1906, the newspaper reported that "Mr. and Mrs. F. B. [sic] Harrington, in their Ford Runabout, are touring the Berkshires. They will be away for about two weeks."

off the other charges, making his total cost \$656.45, paid on November 2, 1907. On the other hand, a Model K, shipped in November 1907, listed for \$2,994 including a \$150 top and \$46 lighting equipment. Weeber's discount was 20%.⁶⁷⁴

Most of Weeber's communication to the Ford Company was with the New York Branch at 1723 Broadway in New York City. In addition to regional distribution of cars and parts, the Ford branch, which opened in late 1905, served as a local retail Ford agency.⁶⁷⁵ Gaston Plantiff was the branch manager. A man of significance in the evolution of the Ford Company had a cordial relationship with Christian Weeber. Plantiff wrote to Ford in November 1907 ostensibly to note that he had shipped a radiator and hoped "it will prove to be all right." Plantiff continued,

Let me hear from you as to how you are getting along. I expect to be up your way again next week but in the meantime do not fail to let me know if there is anything we can do to help sales or promote the game in any way.

Thanking you for past favors, and with kind regards, beg to remain,⁶⁷⁶

A month later Plantiff wrote that he wanted to ship a Model K Runabout "as is" to Weeber, who then could have a "local carriage dealer widen the seat later on if necessary. We would like very much to ship this up to you this month so as to make

⁶⁷⁴Pencil notations on the invoice note that the "Presto tank" and gas piping were omitted. *The Horseless Age*, October 3, 1906, noted reports "that agents' commissions on the Ford four-cylinder runabouts will be reduced by 20 percent to 10 percent the coming year. Six-cylinder touring cars will be built with very few changes from the 1906 model." Apparently, the prospective change in commissions remained only a rumor.

⁶⁷⁵*The Horseless Age*, vol. 16, no. 4, July 26 1905; vol. 16, no. 16, October 18, 1905. John Wanamaker had served as Ford agent in New York City prior to the establishment of the Ford branch. In late 1903, C. A. Duerr & Company were "agents for the Ford car" moving from 38th Street to 1787 Broadway at 58th Street for sales, "retaining a garage and repair shop at 50 West Fourth-third street." See *The Horseless Age*, November 25, 1903, vol. 12, no. 22. On September 16, 1903, the journal reported that the Duerr firm at 152 West 38th Street "has recently taken the agency of the Ford automobile" and the first Fords "have recently arrived at the Thirty-eighth street office of the Ford Company."

⁶⁷⁶Plantiff to Weeber, November 19, 1907. Other correspondents at the New York branch included E. S. Whitmore, Edward T. Baskett, William Becket Harding, A. C. Vanderpoel and M. B. Leahy. In a letter to Weeber dated February 25, 1908, Vanderpoel said that, "Mr. Harding, with whom you had your original conversation, is no longer with us..."

your business for December show up big to the factory."

Seemingly, the information about the seat was in response to a Weeber query, who also had asked about Model S cars. Plantiff said:

We are a little short on S's at present but will stretch a point in your favor if you are in need of any, but please let us know as soon as possible so that we can make our arrangements at this end.

We are glad to see that things are so bright up your section and know you will continue to do a good business this winter.⁶⁷⁷

Weeber penciled on the Plantiff letter that he had answered on December 23 and was "waiting for wire."

A Model K Runabout, serial number 795, duly was billed on December 31. Its final retail cost was \$2,809.50 plus \$37.50 for shipping. Weeber's discounted obligation was \$2,280.75, a debt paid on January 7th, 1908. The C. F. Weeber Manufacturing Company did, in fact, receive at least three Model S cars in December; one was invoiced on December 7 and two, likely as a result of Weeber's request to Plantiff, on December 31, 1907. The customer charges for each were \$721.80 for the first car and \$722.50 for the later two. Of this higher total, \$1 was for gas and oil, \$2.50 for "time & expenses" and \$19 for freight. Weeber's cost less his agency discounts was \$617.25. A month earlier, he had received a Model N, which fitted with top, lamps and horn and delivered with two gallons of gasoline (\$.50) and one gallon of oil (\$1), listed for \$686.30. The discounted price was \$582.30.

Surviving correspondence regarding Ford replacement parts in late 1907 includes that about a Model K transmission. The customer price was \$80. Weeber's 25% discount on parts made his cost \$60 less a \$20 allowance for the old transmission shipped prepaid express. Weeber also received a note from the Ford factory in Detroit in reply to a query from him about a noisy Model N transmission. The manufacturer advised that "no doubt but what a new set of gears would remedy the noise to a large extent, particularly if the teeth on the old gears are worn off very much." Weeber also was told that the Ford Company "would not care" to furnish running boards and fenders for Model N cars since the vehicles were designed without such

⁶⁷⁷Plantiff to Weeber, December 21, 1907.

equipment, "and we would be very much opposed to having anyone alter the design."⁶⁷⁸ Also, in late 1907, the New York Branch replied to Weeber's order for a "bronze worm" (gear) and front springs for a Model B Ford, a car built for the 1904 and 1905 model years.

A Western Union Telegraph Company telegram from the Ford Motor Company in New York to "C F Weber Mfg Works" is dated April 6. There was no year designation. The text, "Have not got [sic] model F. Cylinders [sic] in stock," suggests a period early in Christian Weeber's career as a Ford agent since the Model F went out of production in 1906.



Interesting and somewhat mysterious letters to Christian Weeber in December 1907 and January 1908, suggest that the writer, J. Frank Boylan of Pittsfield, Massachusetts, served as Weeber's agent in an attempt to sell at least one Ford car. The first letter, from December 11, 1907, forwards Boylan's Pittsfield address, "trusting you will have occasion to use it in the near future." On December 19, Boylan wrote that he was going to:

...be in New York next week and should like to take the madam for a Ford demonstration while there as I shall meet her at that time and place.

If you think it is necessary I trust you will send me a letter of introduction. On my way back shall stop off in Albany and make you a call...

On January 8, Boylan wrote:

I am giving the proposition you offered my considerable thought and I shall be with you Monday am. Believing that at that time we can reach an agreement and get down to business without any further delay.

The final two letters apparently conclude Boylan's end of the correspondence. On January 22, he wrote to say that Weeber no doubt was wondering what had happened. Boylan continued:

My eyes have got so bad that I am compelled to give up and I simply took my things and returned to Pittsfield as I could not afford to be idle in Albany

⁶⁷⁸Letter signed "R.L. [illegible?] A." and dated December 7, 1907.

I do not know how long I shall have to remain idle on this account so perhaps you had better not wait for me as it is liable to be some time in fact I believe I shall have to have some operations before I get through with it.

However I shall do my best to carry that sale through with Mrs. Gay.

The last Boylan letter is dated January 28, 1908. In it, he acknowledges a letter from Weeber and reports that his eyes are much better, so much that he would be "getting busy again."

I guess I quit that Albany Doctor just in time to save my eyes and that is all. Have not been able to see Mrs. Gay since I returned home so can give no news at this time. However I shall see her in the near future.

I have nothing in store for the future in case you happen to hear of anything I should appreciate considering it.

On this final Boylan letter, Weeber noted that he had answered, probably on February 6.⁶⁷⁹



Another prospect for a car purchase was Clifford A. Booth of Delmar. His name was forwarded to Weeber from the Detroit offices of the Ford Motor Company, which had corresponded with Booth. "As this territory is under your jurisdiction, we would suggest that you get in touch with the gentleman and see if it is not possible to secure his order."⁶⁸⁰ An attachment with the New York branch address to the letter requested Weeber to "Kindly report result of your interview with this prospect as soon as possible."

December 1907 was the time for Weeber to contract for distribution rights for the 1908 year. On December 11, Plaintiff wrote, "returning you [sic] contracts and ask that you kindly sign the rider under the word Accepted, which you will find attached to each copy, and return same to us by next mail. We regret to trouble you again in this matter but feel that it is better to embody all agreements under one contract."⁶⁸¹

Apparently, Weeber had asked about including Schoharie County in his operating territory but on December 18, Plaintiff wrote to him that Schoharie

⁶⁷⁹Weeber's notation is "Ans. 2/6."

⁶⁸⁰A.H. Sargeant for the Ford Motor Company to Weeber, December 11, 1907.

⁶⁸¹Plaintiff to Weeber, December 11, 1907.

had been “closed by our factory to the Heller-Spawn Motor Car Co. of Binghampton [sic].” Weeber, nevertheless, maintained a large distribution area, advertising that he was “General Agent and Distributor for Ford Cars in Albany, Columbia and Rensselaer County Below Troy”.⁶⁸² In January 1908, the Ford branch forwarded to Weeber a sample contract “we think you might use with your sub-agencies.”⁶⁸³

In March 1908, Plaintiff wrote to the Weeber Manufacturing Company [sic] asking for a list of all its contracted sub-agents. Because many such agents in Weeber’s territory were buying parts, it was to Weeber’s advantage to have those purchases credited “in on your rebate.” Also, the Ford “factory” wanted the list because “they are anxious to have a representative in every city and town and they have asked us to see that you close up with someone in each and every town in your territory regardless of whether he purchases a car at once or not.” Plaintiff closed by noting he expected to be in Albany in a week or ten days, “when he will call upon you.”⁶⁸⁴

In February 1908, Plaintiff had written to Weeber regarding a matter not made explicit in the short letter but perhaps referring to sales territory in Saratoga County. The letter specifically reads:

As I am leaving for the factory tomorrow it will be impossible for me to take up the matter of the Saratoga proposition which was talked over with your Mr. Weeber last week.

Just as soon as I return from Detroit I will advise you and we will attend to the matter.⁶⁸⁵

Perhaps it was the eventual diminution of this territory which led, in part, to the end of business dealings between the Weeber and Ford companies. By late winter 1913, some 2,000 Ford dealers were documented in the United States. Alan Nevins has noted, “Year by year, it was the policy of the company to reduce the area allotted on dealer and increase the number of dealers.”⁶⁸⁶

Invoices surviving from early 1908 indicate that the C. F. Weeber Manufacturing Company purchased eight Model S cars (serial numbers 730, 725,

740, 752, 759, 745, 747, 750) in January; one Model S (serial 46) and one Model N (serial 5872) in March; and one Model S (serial 1709) in May. Surviving sight draft receipts for the first six months of the year show payments to the Ford Motor Company totaling \$19,709.85.⁶⁸⁷ Plaintiff wrote to Weeber in January acknowledging a telegram ordering four Model S cars, “two with tops and have immediately telegraphed our factory to ship same forward.” He concluded, “Thanking you for the order and trusting to have the pleasure of seeing you before long, we beg to remain.”⁶⁸⁸

Christian Weeber advertised the Ford cars in the Albany newspapers. In January, he requested from the Ford Motor Company electrotypes of all the Ford models. However, a response from Detroit indicated that the N, R and K roadster electrotypes were out of stock.

We have mailed you a single and double column “S” cut, and a small cut of the touring car [probably a reference to the coming Model T] and hope you will be able to get along for the present with these, but if it is absolutely necessary that you have the other cuts, please advise and we will have same made up for you.

Weeber noted in pencil on the Ford letter, “CW 1/16 ordered double & single. . . K Roadster & N [Model N].”⁶⁸⁹ In fact, in Weeber display advertisements in the winter of 1908, engravings depict a Model K touring car, a K roadster, a Model N, a Model S runabout and a Model S roadster.⁶⁹⁰ In February, the Ford Company advertising department in Detroit wrote that they would be sending Weeber the 800 catalogues he requested. And they added, apparently having seen some Weeber advertisements we notice that you are using an old cut of the roadster, which is very bad, and the N cut does not do the car justice. Please see that these

⁶⁸⁷These drafts date from January 2 (\$3,515), February 21 (\$2,040), March 24 (\$1,244.85), May 8 (\$2,550), May 15 (\$2,550), June 3 (\$2,550), June 5 (\$2,710), and June 15 (\$2,550). All were made payable to the order of the Corn Exchange Bank of New York paid through the Albany Trust Company.

⁶⁸⁸January 8, 1908.

⁶⁸⁹The Ford letter, dated January 13, 1908, is signed by “R.T.W.: for the “Advertising Dept.”

⁶⁹⁰See, for examples, *The Argus*, February 16, and 23, 1908, as well as March 1, 15 and 29, 1908. Also, the *Albany Evening Journal* for February 22 and 29, 1908.

⁶⁸²*The Argus*, various issues in February and March 1908.

⁶⁸³Whitmore to Weeber, January 14, 1908.

⁶⁸⁴March 4, 1908.

⁶⁸⁵Plaintiff to C. F. Weeber Mfg. Works, February 17, 1908.

⁶⁸⁶Allan Nevins, *Ford: The Times, the Man[,] the Company* (New York: Charles Scribner’s Sons, 1954), p. 401.

are changed and we think it will improve the looks of your advertising.⁶⁹¹

A following letter, dated February 12, 1908, confirmed a telegram that informed Weeber that the 800 "N & S catalogs" were being shipped by the printer. While Weeber might "find the covers of these a little soiled for the reason that they were not thoroughly dry, but we did not wish to inconvenience you by delaying the shipment, knowing that you were in such urgent need of these books."⁶⁹²

An advertisement in the *Albany Evening Journal* for February 29, 1908, has a cut of the Model N and those showing various S and K models, suggesting use of a new illustration as recommended by the Ford Motor Company. This Weeber advertisement also describes the coming Model T, "expected to be ready for delivery shortly. Body design similar to **MODEL K**...The price has not been definitely decided, but will be between \$850 and \$1,000...**Don't order any light 5-Passenger touring car until you have seen this model. Orders now being taken to be delivered as received. Call to see Photos and get full particulars.**" It would be many months, however, before the first Model Ts arrived in Albany.

In the same February 1908 advertisement, Weeber was more specific about deliveries of the Model S roadster, a variation of the Model S runabout. With a roadster on display, he expected the first car load on March 10. "Judging from orders already booked it will be in great demand." Another new car, the \$800 Model S coupe, had just "been brought out for Physicians and others wishing an enclosed car for winter and stormy weather use." The February 29 advertisement, noting Wednesday and Saturday evening business hours, also mentioned the continuing Weeber car giveaway contest described below.⁶⁹³

On February 13, 1908, the Ford factory office wrote to Weeber to acknowledge receipt of a telegram and to promise shipment of three Model S

coupes "within the next three or four days."⁶⁹⁴ A letter to the Weeber firm in February 1908 indicated the roadster different from its runabout in being fitted with a rumble seat and having the fenders and running boards enclosed as on the Model K. "The standard color is red and positively no option will be given." Christian Weeber, pleased with the opportunity, noted on the letter in pencil, "Ordered by wire 4 roadsters 2/21 PM."⁶⁹⁵ On February 21, M. B. Leahy of the New York Branch wrote that the company was in receipt of two telegrams, one regarding payment for the coupes and the other regarding the S roadsters. For the latter, "...we will not require a deposit on this shipment, that part of the letter was for the attention of our smaller agents." Leahy wrote again on March 14 to say that a Model S was on display in the New York Branch showroom. "The car is all that we have claimed for it and in fact shows up better than the photograph and has created quite a sensation along Broadway." He encouraged Weeber to "drop in and take a look and you might bring along any customers who are interested." Because of the demand for the S roadster, shipments of N and S runabouts were to be delayed. Weeber noted on the letter boldly in pencil, "Ans. 3/18 (4 I witti [illegible?]) (4 roadsters)."

During the winter of 1908, Plaintiff wrote to Weeber twice to promote the use of automobiles by business enterprises. "We refer particularly to telephone, lighting, gas and other companies employing outside men." Plaintiff's first letter urged Weeber to make "a thorough canvas of your territory along these lines." The second letter asked Weeber for a book of testimonials to get in touch with:

...any Ford owners in your territory who are using their cars in business and have them write letters as to their experience. We do not mean doctors particularly as the automobile has come to be an accepted factor in their profession, but rather we want letters from electric lighting, real estate, life insurance or other concerns employing men in outside work, and from Water and Fire Departments. Try to have them emphasize the value of an automobile in their business, showing the amount of work accomplished and time

⁶⁹¹The letter, dated February 7, 1908, is signed "R.T.W."

⁶⁹²This letter also was signed "R.T.W." A following letter with a similar signature from February 26, 1908, advised the Weeber firm that the Ford Company was having "the Engraving Company mail you two 4" electros and two 2," of the new Model S Roadster car..."

⁶⁹³An *Albany Evening Journal* advertisement one week earlier, on February 22, 1908, has no mention of the Model S roadster but does show the "just brought out" coupe.

⁶⁹⁴This letter was signed by Stanley Roberts for the sales department

⁶⁹⁵The letter from the Ford branch in New York was signed by M. B. Leahy.

FORD MOTOR CARS

Can Now Be Seen in the Following Models at the
C. F. Weeber Mfg. Works Show Rooms
170-172 Central Avenue

General Agent and Distributor for Ford Cars in Albany, Columbia and Rensselaer County Below Troy.

We are the pioneers in the Auto business in Albany. We built the first complete Automobile that dates as far back as 1896. Our repair shop is the largest and finest equipped in this part of the State, and every one who addition is complete it will triple our present plant.

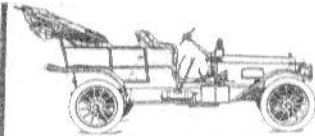

FORD Model K, 6-Cyl., 40 H. P.
\$2,800. Fully Equipped \$3,000

This is the most striking automobile yet made, and also the most complete. It has 60 horsepower and is the most powerful engine ever made. It has 120 miles per hour and is the most powerful engine ever made. It has 120 miles per hour and is the most powerful engine ever made.

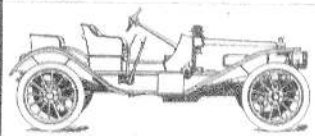

FORD K Roadster, 8-Cyl., 40 H. P.
\$2,900 Fully Equipped

This car has the latest motor ever made. It has 80 horsepower and is the most powerful engine ever made. It has 120 miles per hour and is the most powerful engine ever made.



FORD Model S, 4-Cyl., Coupe, 18 H. P.
\$800 F. O. B. Factory

This is the most wonderful small "Roadster" ever made. It has 18 horsepower and is the most powerful engine ever made. It has 120 miles per hour and is the most powerful engine ever made.

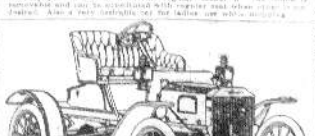

FORD Model S, 4-Cyl., Runabout, 18 H. P.
\$700 F. O. B. Factory

This is the most wonderful small "Roadster" ever made. It has 18 horsepower and is the most powerful engine ever made. It has 120 miles per hour and is the most powerful engine ever made.

FREE CATALOGUE NOW BEING SENT TO ALL WHO WANT IT. The first one that you can get is the BEST NUMBER. It contains the names of the FORD CATALOGUE from the season to the 1908. It contains the names of the FORD CATALOGUE from the season to the 1908. It contains the names of the FORD CATALOGUE from the season to the 1908.

OPEN WEDNESDAY AND SATURDAY EVENINGS.

PROSPECTS BRIGHT FOR AUTO SEASON

LOCAL LEAD PLANNING TO INCREASE IN THE COMING MONTHS. THE YEAR 1908 IS EXPECTED TO BE THE MOST SUCCESSFUL ONE SINCE THE INTRODUCTION OF THE AUTOMOBILE.

Albany and Troy managers expect to see a large increase in the sale of cars for the coming season. They expect to see a large increase in the sale of cars for the coming season.

At the same time, the managers expect to see a large increase in the sale of cars for the coming season. They expect to see a large increase in the sale of cars for the coming season.

At the same time, the managers expect to see a large increase in the sale of cars for the coming season. They expect to see a large increase in the sale of cars for the coming season.

At the same time, the managers expect to see a large increase in the sale of cars for the coming season. They expect to see a large increase in the sale of cars for the coming season.

At the same time, the managers expect to see a large increase in the sale of cars for the coming season. They expect to see a large increase in the sale of cars for the coming season.

At the same time, the managers expect to see a large increase in the sale of cars for the coming season. They expect to see a large increase in the sale of cars for the coming season.

At the same time, the managers expect to see a large increase in the sale of cars for the coming season. They expect to see a large increase in the sale of cars for the coming season.

At the same time, the managers expect to see a large increase in the sale of cars for the coming season. They expect to see a large increase in the sale of cars for the coming season.

At the same time, the managers expect to see a large increase in the sale of cars for the coming season. They expect to see a large increase in the sale of cars for the coming season.

At the same time, the managers expect to see a large increase in the sale of cars for the coming season. They expect to see a large increase in the sale of cars for the coming season.

At the same time, the managers expect to see a large increase in the sale of cars for the coming season. They expect to see a large increase in the sale of cars for the coming season.

At the same time, the managers expect to see a large increase in the sale of cars for the coming season. They expect to see a large increase in the sale of cars for the coming season.

At the same time, the managers expect to see a large increase in the sale of cars for the coming season. They expect to see a large increase in the sale of cars for the coming season.

At the same time, the managers expect to see a large increase in the sale of cars for the coming season. They expect to see a large increase in the sale of cars for the coming season.

At the same time, the managers expect to see a large increase in the sale of cars for the coming season. They expect to see a large increase in the sale of cars for the coming season.

Do you wish to dispose of your old car?

I will offer you the highest possible value in exchange for the relinquished

STEVENS-DURYEA LIGHT SIX
LET ME MAKE YOU A PROPOSITION



FIRST COST vs. UPKEEP

The Stevens-Duryea Light Six is a car of moderate size, cost and no up-keep whatever. It is a car that will give you the most pleasure for the least money.

THE LIGHT SIX, (6-CYL.) 35 H. P. - - - - \$3,500
MODEL X (4-CYL.) 24 H. P. - - - - 2,750

C. S. Ransom,
15 E. Pearl Street
Stevens-Duryea Motor Cars

THE OLDSMOBILE

Considered by those who know to be the most reliable car on market.

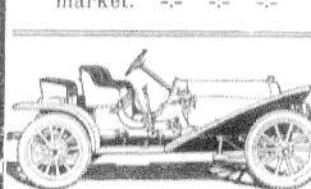

The 45 H. P. Oldsmobile \$2,750
Runabout, fully equipped

If You Are Looking for a Runabout Try

The OLDSMOBILE
ALBANY AUTOMOBILE EXCHANGE
LARGEST DEALERS
ALBANY TROY
Lark and State Streets 22-24 Fourth Street

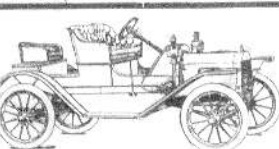

FORD MODELS, Roadster
4 Cyl., 18 H. P.
\$750 F. O. B. Factory

This is being to be the most popular light Roadster for 1908. It has 18 horsepower and is the most powerful engine ever made. It has 120 miles per hour and is the most powerful engine ever made.

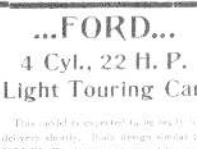

...FORD... 4 Cyl., 22 H. P. Light Touring Car

This car is expected to be the most popular light Roadster for 1908. It has 22 horsepower and is the most powerful engine ever made. It has 120 miles per hour and is the most powerful engine ever made.

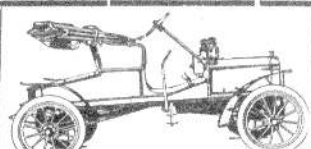

FORD MODEL N, 4-Cyl., 18 H. P. Runabout
\$600 F. O. B. Factory

This is the most popular Runabout on the market today. It has 18 horsepower and is the most powerful engine ever made. It has 120 miles per hour and is the most powerful engine ever made.

Figure 8.2: Display advertisement from *The Argus*, March 1, 1908. While displaying all the Ford models available in the late winter of 1908, this Weeber advertisement announced the coming Model T. "Orders now being taken to be delivered as received. Call to see Photos and get full particulars." Courtesy of New York State Library, Manuscripts and Special Collections.

saved, as well as the moderate cost of maintenance.

Please answer by return mail telling us about how many letters we may expect from your territory. Do not neglect this matter but take hold and help us to get this book published quickly as it will be of great value to yourself as well as to us.⁶⁹⁶

Weeber marked “over” on the second Plaintiff letter and on the reverse, in fact, made a list in pencil of ten names, three of which are crossed out. Included were Frank Newcomb, Mr. Haberlin, Mr. Heiderich? [illegible?], Mr. Van Hoesen, Henry Martin, Dr. Troidel [illegible?], Dr. Marshall, Mr. Lansing, Mr. Pruitt [illegible?], and Mr. Battershall.⁶⁹⁷ On February 18, M. B. Leahy wrote to Weeber asking, “How about the testimonial letters from customers using Ford cars for business purposes?” Weeber noted in pencil, “Ans. 2/20.” His answer apparently was an explanation of his not wishing to distress his clientele. Leahy wrote a day later that, “We note what you say with reference to obtaining testimonial letters and of course do not wish you to annoy your customers but are anxious to get in all that we can before publishing our new booklet.” Apparently no copy of the booklet, if published, survives in the Weeber collection at the New York State Museum.

By early 1908, Christian Weeber’s success as a Ford dealer allowed him to sponsor a contest with a Ford runabout as a prize. Thanks to his “making great account of the Ford cars this season,”⁶⁹⁸ Weeber was able to write off his (\$510) cost of a \$600 Ford N as well as those expenses of the second-prize speedometer and third-prize automobile clock. The Weeber Manufacturing Company explained:

The first one that can make up the RIGHT NUMBER OF NAMES contained in the FORD CATALOGUE, from the letters in the title C. F. WEEBER MANUFACTURING WORKS will be the winner of the FORD RUNABOUT. Catalogues, Blanks and Envelopes will be furnished and time stamped as received, in presence of contestant. Contest

⁶⁹⁶Plaintiff to Weeber, January 20, 1908 and February 4, 1908.

⁶⁹⁷The Albany directory for 1908 lists John P. B. Haberlin, an embalmer; Benno G. Troidle, a physician; Bertram E. Marshall, a physician; and Fletcher W. Battershall, superintending court reporter and lawyer. The other names on Weeber’s list have multiple entries for the same surname.

⁶⁹⁸*The Argus*, February 2, 1908.

will close MAY 2ND. After closing, judges will be appointed to decide on the correct number, and then the envelopes will be opened and the correct ones awarded, according to its entry. THIS CONTEST IS OPEN TO ALL WHO ARE SIXTEEN YEARS OR OVER. Call and inspect our large stock, equipment and plant, and see that what we say is correct.⁶⁹⁹

The Argus commented:

Now, a Ford runabout is not picked up every day, and there are some hundreds of folk who listen to the honk! honk! of the automobiles whizzing by with a distinctly envious feeling because automobiles are only purchasable by folk with money to burn in gasoline. Those hundreds of folk have the finest possible chance to win the Weeber prize by the exercise of some simple arithmetic and a careful survey of the Ford catalogue. The idea of the contest is to secure careful reading of the Ford catalogue by the Albany public; but the idea of the contestants will be to win then Ford runabout. This is how it is to be done: The contestant making up the right number of names contained in the Ford catalogue from the letters in the title, “C. F. Weeber Manufacturing Works” gets the Ford runabout.⁷⁰⁰

The *Sunday Press* also took note of the contest, perhaps, in part, because of a very large Weeber display advertisement on March 29, 1908.

The Weeber advertisement, noting the firm’s status as “general agent and distributor for Ford cars in Albany, Columbia, and Rensselaer County below Troy,” featured the illustrations and information about two different Model K cars; three Model S versions; and the coming “most marvelous light touring car” Model T. Introducing the illustrated cars, Weeber said:

We are the pioneers in the Auto business in Albany. We built the first complete Automobile that dates as far back as 1898. Our repair shop is the largest and finest equipped in this part of the state, and when our new addition is complete it will triple our present plant.

While many Weeber display advertisements utilized text provided by the car manufacturers, this example includes information obviously written

⁶⁹⁹The rules were published as part of a display advertisement that appeared in the February 2, 1908, edition of *The Argus*.

⁷⁰⁰March 29, 1908.

by Christian Weeber or an employee. For example, of the K roadster he said it held the record for the fastest time between New York City and Albany. Of the S roadster there were “[t]hree carloads now on order which will arrive shortly. Please you order now and not get disappointed.” And the S coupe was a “very desirable car for ladies’ use while shopping.”

Meanwhile, the Weeber showroom, open for business six days and Wednesday and Saturday evenings,⁷⁰¹ was decorated with red, white and blue electric lights. A “large force [was] now at work planning for the spring trade.” The repair shop, already “the largest and finest equipped in this part of the State,” was going triple in size with an addition. And the contest “stimulated a great amount of enthusiasm for the [giveaway] scheme.”⁷⁰² In mid-February, Weeber received “a carload of coupes...and these are growing in favor. The Ford runabout and the Ford roadster are selling well and he reports several sales of new cars.”⁷⁰³

By March 1, Weeber could report “a number of sales during the past week and lively interest in the prize contest for the Ford runabout.”⁷⁰⁴ Unfortunately, the author of the present work has not determined if the car duly was given to a contestant. There is, however, documentation and the record of the awarding of a Model S roadster from the C. F. Weeber Manufacturing Works in a second contest sponsored by the *Press-Knickerbocker-Express* and *Sunday Press* in the late summer and fall of 1908.

The newspapers’ event combined a popularity contest with a competition to sign up subscribers. In addition to the Model S, the publisher distributed two pianos, diamond rings and gold watches to the runners up. The contest was open to “The Most Popular Young Ladies, Either Single or Married, in Albany and Vicinity.” Nominating a contestant awarded that woman 1,000 “votes.” Single votes could be clipped from the daily newspaper. Multiple votes could be secured by subscribing to the papers with vote numbers ranging from 200 for a three-month subscription to the

⁷⁰¹An advertisement in *The Argus*, March 29, 1908, says the Weeber business was open on Tuesday and Saturday evenings.

⁷⁰²*The Argus*, February 2 and 9, 1908. By the latter date, “a number of entries” already had been received.

⁷⁰³*The Argus*, February 23, 1908.

⁷⁰⁴*The Argus*, March 1, 1908.

Press-Knickerbocker-Express to 12,500 for a five-year subscription to both papers. Two weeks before the contest ended, at the end of October, there was a period when the subscription votes were doubled, i.e., ranged from 400 to 25,000.

The *Sunday Press* said of the prize car:

The automobile which is offered absolutely free in this great contest is a brand new Model S Ford roadster. A 15-horsepower, 4-cylinder car of rakish design fully equipped with rumble seat, semi-enclosed body, long sweeping fenders, lamps and running board.

The automobile is on display at C. F. Weeber Mfg. Works automobiles and supplies, 170 and 172 Central Ave., and will also be seen on the principal streets on pleasant days. It will be awarded to the young lady receiving the largest number of votes in the great contest. . .

The \$350 pianos which are offered as second and third grand prizes in this contest are, the celebrated Sanford pianos, style 12. They are on exhibition at Cluett and Sons’ popular music house on State Street. Call and try them. . .

The diamond rings and gold watches are beauties and well worth striving for. They are given as district prizes, a diamond and a watch to each district after the three grand prizes have been awarded.⁷⁰⁵

What arrangement the Weeber Works made for selling the car to the newspaper publisher is unknown here. Obviously, if the car had been a gift from the Weeber concern, that information would have been made public. An engraving in the October 19, 1908 *Press-Knickerbocker-Express* of a piano similar to the prize Sanfords was accompanied by the statement that those prizes were “purchased from Cluett & Sons.”

Mrs. Joseph A. Burkhart, with 310,721 votes, claimed the Ford. Second and third place contestants, winners of the pianos, were Mrs. James L. Hyatt, Jr. (291,057 votes) and Margaret Harlfinger (254,436).⁷⁰⁶ Judges for the contest were George

⁷⁰⁵September 20, 1908.

⁷⁰⁶A check of Albany city directories including the listings for Rensselaer did not turn up a Joseph A. Burkhart although there was a Joseph A. Burke, a foreman, living at 81 Lark Street in Albany. James L. Hyatt, Jr. was an assistant engineer at the State Armory. Another James L. Hyatt, likely the younger man’s father, was Albany police chief. The 1910 census lists Margaret V. Harlfinger, born about 1889, as the wife of John A. Harlfinger. An unmarried Margaret Harlfinger appears as dependent daughter in the 1900 census.

Addington, county judge; Frank A. McNamee, civil service commissioner and insurance executive; and Patrick H. McDonald, eighth ward alderman.



It's likely that the contract between the C. F. Weeber Manufacturing Works and the Ford Motor Company for the 1908 model year does not survive. There is, however, a duplicate of a form dated September 26, 1908, on which the Weeber concern listed purchases as it sought rebates from Ford "under our contract dated Jan. 4, 1908." The purchases totaled \$32,129.80. The rebate sought at 3% amounted to \$963.89. Given the evidence of carload (four autos) shipments to the Weeber Manufacturing Works in 1908, it's likely the rebate was earned entirely as a result of the Weeber firm exceeding a predetermined purchase figure rather than the Weeber operation having earned a portion of the rebate through the sales of sub-agents.

The rebate certificate lists the purchase by the Weeber company of two Model N cars (in November 1907 and March 1908); no Model R cars; sixteen Model S runabouts (possibly sometimes known as the Model R) between early November 1907 and September 29, 1908; twenty-five Model S roadsters between March 24 and June 15, 1908; and two Model K cars, one each in November and December 1907. Included in the rebate total was \$80 for two automobile tops. Otherwise, the \$32,129.80 was formed by the discounted, i.e., wholesale, price of the cars.⁷⁰⁷

Christian Weeber's appreciation for the Model S is reflected in the number of such cars, especially the roadster version, he bought. After this variety became available, only one runabout was received, while twenty-five of the former came to Albany from New York.

⁷⁰⁷The individual purchases are listed by date and dollar amount. The Model N bought on November 18, 1907, for example, cost the Weeber Company \$582.30. The car load (four vehicles) of Model S autos in January 1908 was \$2,460. The Model K purchased on December 1907 was \$2,285.25. A Weeber advertisement in *The Argus* for April 19, 1908, lists the Ford line for 1908. This included the \$600 N, \$700 S runabout, \$750 S roadster, \$800 S coupe, \$2800 K touring, \$2800 K roadster and \$850 T touring. The last, of course, was not available at the time. There is no listing for the R. All prices were freight on board except the for the poor selling K models, which were \$2,800 delivered.

In spite of Christian Weeber noting in March 1908 an "increased demand for the six-cylinder car this season,"⁷⁰⁸ it's obvious that the Model K also had limited appeal. Plaintiff wrote to Weeber in early April 1908, that the New York Branch of the Ford Motor Company "fear[ed] that in the excitement of taking orders for the Model 'S' roadsters you have lost sight of the six cylinder cars." Plaintiff continued by saying the "outlook in New York for the delivery of Ford Sixes is very bright and we believe that you could secure some business for your territory if properly worked." He concluded by offering to assist in demonstrations "or in any other way possible," and by suggesting that "Deliveries to you of the 'S' Roadster and Touring Car (when they come through) will depend largely on your ability to handle our full line, as preference will be give to those who do."⁷⁰⁹

Ten days later, Plaintiff wrote again to ask if there might be prospects for a Model K. If so:

... we will send at our expense a six cylinder Model "K" Car and a demonstrator to help close the sale.

As we are making this [s]ame offer to a number of other Agents in this locality, it will be necessary for you to reply at once and in answering please note following.

Name three dates for demonstrations and if possible we will fill the first, if not the second or the third.

State whether you want a Model "K" touring car or a Six-Forty roadster and how many demonstrations we will be asked to make."⁷¹⁰

A month earlier both Plaintiff and M. B. Leahy had written from New York about the prospect of Ray Hubbell of Northville becoming a Model K customer. Hubbell, as owner of a Model B Ford, had been brought to the Ford Motor Company's attention by their agent J. W. Sisson in Gloversville. Hubbell was having his B repainted and "put in first class condition" with the goal of trading it for a six-cylinder car.

Sisson was "not in a position to take this car" and had "turned Mr. Hubbell over" to the New York

⁷⁰⁸Indirect quote in *The Argus*, March 29, 1908. Weeber is also credited with observing that there was "a large sale of the runabout roadster."

⁷⁰⁹Plaintiff to Weeber, April 4, 1908. The reference to the "Touring Car" probably refers to the Model T.

⁷¹⁰Plaintiff to Weeber, April 14, 1908. Weeber noted in pencil, "an[swer] 4/15."

FORD ON TOP
ALSO
Our Number of Sales
Which Speaks for Its SUPERIOR QUALITY and Most
Exceptional AUTOMOBILE VALUE in the World.

C. F. WEEBER MFG. WORKS
170-172 Central Avenue
General Agent and Distributor for Ford Cars in Albany, Columbia, and Rensselaer County Below Troy.

DON'T EXPERIMENT — BUY A FORD
and you will be a Pleased Possessor of a Four or Six Cylinder Car.

1908 MODELS

Model "N," 4-cyl. Runabout	\$600 f o b factory
Model "S," 4-cyl. Runabout	\$700 f o b factory
Model "S," 4-cyl. Coupe	\$800 f o b factory
Model "S," 4-cyl. Roadster (as cut)	\$750 f o b factory
Model "T," 4-cyl. Touring Car	\$850 f o b factory
Model "K," 6-cyl. Touring Car or Roadster	\$2800 delivered

Order Now. We Have Six Models on Exhibition.
See Standing Notice on page 1.

Figure 8.3: Display advertisement from *The Argus*, April 19, 1908. A couple in a Model K Ford roadster were on top of the world in a Weeber advertisement of the 1908 Ford line. Courtesy of New York State Library, Manuscripts and Special Collections.

Branch. Since Weeber was “not far from Northfield we thought you would be in a better position to handle this proposition than anybody else.” While Hubbell reportedly wanted \$1,000 for his car, the New York Branch had told him that Weeber would offer \$800 or \$850 “but of course [we] made him no terms whatever.”⁷¹¹

On March 7, Plaintiff acknowledged a Weeber letter from the previous day and said, “I am indeed glad that you finally found Mr. Hubbell and that you hung on to him and sincerely hope that you will be able to close with him later on.”⁷¹²

Leahy wrote again on March 13:

We have your favor of the 12th inst., and note fully all that you say in regard to Mr. Hubbell. We hate to feel that Mr. Hubbell would purchase anything but a six cylinder Ford. We know that he was very much pleased with the car when he was here but of course you know how it is when a man has a car to turn in and gets out among the Automobile robbers.

We know that several concerns are cutting prices and making all kinds of allowances on second hand cars in order to move their stuff.

Mr. Sisson is pretty friendly with Mr. Hubbell and we are writing asking him to keep his eye on Hubbell and see that he doesn't do anything rash.⁷¹³

Since the last Model K purchase by Weeber was made on December 31, 1907, it's obvious that Hubbell did not buy such a car from the Weeber firm. Other communications from the Ford Motor Company alerted Weeber of additional prospects for cars. Thus Leahy wrote on February 29, 1908, that C. B. Flint of the Newton Fire Brick Company in Albany was “in the market for a runabout.”

The S roadsters were the vehicle in demand in the early spring. The Ford factory wrote to Weeber on March 26 responding to a letter inquiring about his S roadster orders. Stanley Roberts, for the sales

department, said that no factory direct shipments had been made to Weeber “as yet.” The demand was so great that the factory wished to supply each agent with a demonstrator car, “so that by the time your carload arrives, they will not only be sold, but you will probably have a couple more carload orders in.” Weeber was advised to take up “matters of delivery” with the New York Branch.

Nevertheless, it was the coming Model T that occupied much of the attention of the Ford Motor Company and the Weeber Manufacturing Works. A March 18 letter signed for James Couzens, secretary and treasurer of the Ford Company, was addressed to factory branches and agents. The price of the car had been established at \$850. A delay in getting the essential steel had created a production delay “due to the steel mills being closed down for such a long period on account of the financial depression. . . .” Couzens estimated that it would be July 1 before shipments would begin. In meantime, he urged agents not to accept orders for the new car or advertise it and to promote the N, S and K models. “The line is better and more extensive than last year's, so the Model 'T' should not be particularly missed. Please acknowledge.”

Weeber noted on the Couzens letter that he acknowledged it on March 23. Before the letter had arrived, and perhaps in response to a question to him from a potential customer about Ford Model T taxicabs, on the nineteenth Weeber had telegraphed, “When will you start to deliver T taximeter—wire word to be here by noon.” The next day, the Ford Company telegraphed, “Early part of July, expect to start Taximeter Cab deliveries.” In a March 21 follow-up letter, wrote to the Weeber firm, “Information in regard to deliveries on these cars has no doubt reached you in a general circular letter which we sent out.”⁷¹⁴

In April 1908, the Weeber Manufacturing Works claimed that, “Ford [is] on Top Also our Number of Sales.” A display advertisement listed the N, three versions of the S (runabout, coupe and roadster), the K and the T, as 1908 models, although the last was not yet available.⁷¹⁵

⁷¹¹Leahy to Weeber Mfg. Co. [sic], March 2, 1908.

⁷¹²Plaintiff to Weeber, March 7, 1908. Plaintiff closed the letter “With my regards, believe me.”

⁷¹³Leahy to Weeber Mfg. Co. [sic.], March 13, 1908. Leahy went on to describe the shipping schedule for both versions of the Model S. “. . . orders on these two models have been coming in pretty fast and we have already placed at the factory specifications for twenty-seven car loads which have not yet been shipped.” A portion of a letter from Weeber to J. W. Sisson on March 9, 1908, remains in the Weeber collection at the New York State Museum. Only a few words of the text body survive, “. . . representatives for the Ford cars.”

⁷¹⁴The texts of the telegrams are quoted in Couzens' letter.

⁷¹⁵*The Argus*, April 19, 1908; *The Sunday Press*, April 19, 1908. The prices for the cars were \$600 (N); \$700 (S runabout); \$800 (S coupe); \$750 (S roadster); and \$850 (T touring car). All these prices were fob the factory. The K was \$2,800 delivered. There was no mention of the R model in the advertisement. An early image of the Model T appeared in a Weeber advertisement in

Christian Weeber had his doubts about the Model T. Perhaps it was his satisfaction with the Model S that prompted him to write to the factory to complain about what he perceived as a lack of power in the Model T as well as the location of the steering wheel on the left side of the car in contrast with being on the right side on previous Fords. In a two-page letter, Stanley Roberts assured Weeber that the T was powerful enough.

... Simply because we have not increased the bore, does not mean that the power and pulling power has not been increased to a great extent, for frankly, Mr. Weeber, this Model "T" is a more powerful car for its size, and horsepower, than the Model "N" is, and that is saying a good deal, as you will appreciate. We have had this car out in 14 in. of snow, with full load, and she plows through this snow on high gear without any trouble....

As to the steering gear, this, we believe is going to be a decided selling point. It permits the driver to run up along side of the curb and get out on the sidewalk, without stepping out into the road and then walking around. In the winter, and particularly on wet, muddy days, it is a decided nuisance to get out into a muddy road before getting to the sidewalk. Furthermore, it places you in a position where you can watch the oncoming traffic, and you can handle your car to a great deal better advantage....

Yes—we realize that there will be objections to this but it is simply another evidence of Mr. Ford's wonderful originality.

The Model "N" was objected to from one end to the other, but has proven itself worthy. Perhaps people won't be quite as skeptical about the Model "T," but nevertheless, there will be a number of knocks and suggestions for improvement, but we believe they will all go the way of similar ones on the Model "N."

You can rest assured that this Model "T" is a wonder from one end to the other. For simplicity and power it has surprised everyone, and there is no question at all but what your sales on this will outnumber those of all other models three to 1.

Until you get this car, we want you to bend your entire efforts on the runabout, for there is an enormous trade to be had on this type

The Argus for March 29, 1908. The text promised "the most marvelous light touring car made.... Although this car will be somewhat late in delivery, but it will be wise to enter your order now, so you will get yours in rotation as received."

of car, and then when the light touring car comes out, you will have a line that will enable you to give every single competitor the go-by, and enable you to secure almost the monopoly of the automobile business in your territory.

With best wishes for your continued success, we beg to remain...⁷¹⁶

Plaintiff wrote to Weeber two days later inviting him to an automobile carnival in New York City. Sponsored by the "prominent Automobile Houses," the week-long event in early April was to "commemorate the tenth anniversary of practical Automobile Construction in this Country." A parade, races, hill climbs and other events were on the calendar. Weeber and his customers were encouraged to take part in the parade. The New York Branch of the Ford Company was to be open from 8 a.m. to 10 p.m. "and would be pleased to have you make this Branch your headquarters during the week, and would request that you kindly extend this invitation to the Ford Owners in your territory and also all prospective customers."⁷¹⁷

Plaintiff visited Albany before the carnival, writing to Weeber on April 3 that he regretted not having been able to spend more time together but encouraged "Mrs. Weeber and yourself" to spend a day at the carnival "when I should be very glad to devote my time to you." Plaintiff continued by mentioning that he was still not able to make "prompt deliveries" of the S roadsters but assured Weeber that "you will be one of the first favored ones when the cars commence to come through." As far as S coupes were concerned, "we could get a few more of these if necessary but we are not carrying any in stock at present."⁷¹⁸ On April 13, Plaintiff wired Weeber that "Car load S roadster will be shipped from factory this week." Whether Weeber traveled to New York during the carnival is unknown here but he was in New York soon after; in response to an April 21 letter from Vanderpoel asking for a check for \$22.58 to clear a bill for gasoline and oil. Weeber wrote in pencil, "attend to while at N.Y. 4/24."

⁷¹⁶Roberts to C. F. Weeber Mfg. Works, March 26, 1908. The Weeber display advertisement in *The Argus* on March 29, 1908, noted that the Ford T motor, while rated at twenty horsepower, "shows 26 H.P. on testing brake."

⁷¹⁷Plaintiff to Weeber, March 28, 1908.

⁷¹⁸Weeber noted on the Plaintiff letter, "CV An 4/8."



Figure 8.4: *Ford Times*, May 15, 1909. The New York Branch of the Ford Motor Company decorated for an automobile carnival. NYSM Collection, H-2000.39.151.

Whatever his thoughts on the Model T, Weeber wrote to the New York Branch on April 6 and again on April 8 asking for catalogues. Because no booklets were available in New York, the request was forwarded to the factory. On April 13, a note from advertising manager H. B. Harper in Detroit informed Weeber he was being sent two copies of the “advanced catalogue ‘T.’”⁷¹⁹ It would be, however, some six months before the Ford T cars themselves would be shipped.

Weeber also looked to Ford offices in Detroit and New York for copies of “The Ford March and Two-Step,” a new composition by Harry Zickel, “the well-known composer” and “originator of ragtime in America.”⁷²⁰ The Ford advertising department had said that while “this is intended to advertise our cars, it is gotten out with as little ‘advertisy’ appearance as possible—it possesses real merit as a musical production...” Ford agents were to be charged the cost price of the music; three cents a copy. Piano owners were suggested as “possible auto buyers.”⁷²¹ Weeber invited anyone interested in the Ford March to stop at the Weeber showroom or send a post card “as the music will be given away free.”⁷²² Response to the music, on a national scale, was positive. The Ford Company followed their sending of sample copies with suggestions to further the advertising value of the “Ford March.” Among the suggestions were to “Furnish a copy to each instructor of dancing or owner of a dance academy” as well as to “Send a copy to the schools where the children march in to music.” The piece was being arranged for band and orchestra with plans to arrange it “for automatic piano players, phonographs, etc.” Ford agents were advised that

⁷¹⁹“P.W.” to Weeber Mfg. Company [sic], April 7, 1908; Leahy to C. F. Weeber, April 10, 1908; “H.B.H.” [Harper] to Weeber, April 13, 1908.

⁷²⁰*The Argus*, April 26, 1908. Zickel is credited with writing “Black America” and “Jolly Student.” The Ford piece was “handsomely printed and will find a place and look well on the piano of the ‘most exclusive.’”

⁷²¹Broadcast letter to “All Branches and Agents,” April 6, 1908.

⁷²²*The Argus*, April 26, 1908. H. B. Harper in response to a communication from Weeber complaining about non-receipt of two copies of the “Ford March,” advised that replacements were being sent to “take the place of the two that seem to have gone astray.” For additional copies, “kindly take it up with our New York Branch.” Harper to C. F. Weeber Mfg. Works, April 13, 1908.

“the music [is] the cheapest effective advertising you can secure. . . .”⁷²³

In the late spring of 1908, the Albany Automobile Club sponsored a hill climb in Menands. The May 23 competition took the form of a time trial. The winners being the fastest cars to reach the top one-half mile from a standing start west of the Delaware and Hudson tracks near the Menands railroad station. The sixty contestants were divided into eight classes by number of engine cylinders (for gasoline cars) and, primarily, by selling price.⁷²⁴ Christian Weeber, driving a Model S roadster, proved victorious in the class for the least expensive (under \$850) cars. His time of 1 minute, 35 and $\frac{1}{5}$ seconds was only $\frac{1}{5}$ of a second quicker than the second place finisher, Francis B. Harrington,⁷²⁵ in another Ford S Roadster. Third place was a Ford runabout driven by Fletcher Battershall. Fourth place was taken by a Maxwell.

The Argus noted that spectators were kept apprised of results by blackboards “tacked on poles along the route and where men were engaged in chalking up the times, which was telephoned from the finish.”

The event as a whole attracted much attention from the points nearby and was as interesting and exciting locally as the Baircliff [sic] race which occurred at Westchester county a short time ago. An ambulance was on hand but was not needed due to the good work of the men who were stationed at the sharp curves of the road and who were engaged in swinging danger flags when autos were sighted in the distance, thus preventing accidents. . . .

The Albany Automobile club members have good reason to be proud of yesterday’s event. It was the most perfectly managed affair ever held under auto auspices and there was not a hitch in the entire program⁷²⁶

⁷²³Broadcast letter from the Ford Motor Company to All Agents, April 20, 1908.

⁷²⁴*The Argus*, April 26, 1908.

⁷²⁵The Albany city directory for 1908-1909 lists Francis B. Harrington as assistant to the superintendent of the Union Railroad Station. The superintendent was Frank A. Harrington, probably Francis’ father. The *Knickerbocker Press* for May 5, 1912, noted that Francis A. Harrington of Menands had newly registered a Peerless automobile. The Peerless was an expensive auto, the cheapest 1912 version of which listed for \$4,000.

⁷²⁶May 24, 1908. There was no second hill climb. *The Argus*, May 30, 1909, noted that only fourteen cars had been entered for all seventeen events by the registration deadline.

Christian Weeber, however, did not agree with *The Argus* opinion. A Weeber Manufacturing Works advertisement a week later claimed that the Ford K entry “was BARRED OUT of its CLASS, cars selling from \$2,000 to \$3,000.” The reason “we believe it was done on account of its enormous power and considered it unjust treatment.” A K entered in Class 12 [probably the free-for-all for six-cylinder gasoline-powered cars] “on account of some misunderstanding came too late to take part.”⁷²⁷

The advertisement, of course, emphasized the Model S victory of the car entered by the Weeber Manufacturing Works.

The car was not changed in any particular, but entered with full road equipment. Muffler was not disconnected. Head Light and Rumble not removed. Time 1.35 1-5, all on high gear, which was lower than any car selling up to \$1,750. All Fords entered were winners, as they came in with a good margin over their nearest competitors, which shows FORD RUNABOUTS are a reliable and powerful car.

In addition to claiming a trophy, the C. F. Weeber Manufacturing Works presented the prize for the first event, which was won by a Maxwell Model K, entered by the Central Automobile Company.⁷²⁸ Fastest time of the day, incidentally, was accomplished in the free-for-all race by C. S. Ransom in a Stevens-Duryea six-cylinder car, 53½ seconds.

In July, *The Argus* called Christian Weeber “indefatigable in automobile interests, who is responsible for the Ford boom in this vicinity.” Weeber, of late, had “been bragging about the qualities of a Ford car, its economy and reliability. He gives data to prove what he says from a signed statement from Dr. A. H. Heaton, president of the Sedalia (Mo.) Automobile Club, who is touring through Europe in a Ford runabout, and who started out to

American Automobile Association rules required a minimum of three cars for each class. The climb was to have taken place June 5 on the Kenwood Road. Whether Christian Weeber had submitted an entry form is unknown here. “Baircliff” refers to the Briarcliff races.

⁷²⁷*The Argus*, May 31, 1908. *The Sunday Press*, May 31, 1908. Readers interested in the Model K were advised to “[c]all and inspect our stock and ask for a real demonstration which will prove to your satisfaction.”

⁷²⁸The Maxwell K was a runabout but its retail price of \$1,750 apparently put it into a different class than that in which the Weeber-driven Ford won. See Kimes *op cit*.



Figure 8.5: Photograph by Christian Weeber's friend, Arthur B. Strough, of Weeber driving a Ford Model S to victory in the First Annual Hill Climbing Contest of the Albany Automobile Club, May 23, 1908. NYSM Collection, H-1987.39.9.



Figure 8.6: Trophy awarded Christian Weeber for his Menands Hill Climb victory, May 23, 1908. NYSM Collection, H.-1970.110.43.

prove it could be done on \$4.68 per day."⁷²⁹ What followed were figures likely supplied to Weeber by the Ford Motor Company rather than by Heaton directly.

In early August, Weeber was in Detroit "placing orders for the 1909 Ford runabout and touring car. He is also particularly interested in the new model T car, which is expected to make a hit next season with the autoists."⁷³⁰ Meanwhile the Weeber Manufacturing Works continued, as has been seen, to sell other Ford models. In August, *The Argus* quoted *Ford Times*, Ford Motor Company's magazine, as having a "pleasant compliment" for Christian Weeber, who had spent "several days in Detroit arranging for future business. Weeber is the sort of hustler we would like to have in every city. His record of sixty-nine retail sales this season gives the reason why."⁷³¹

⁷²⁹July 5, 1908.

⁷³⁰*The Argus*, August 2, 1908. The touring car likely refers to the Model T, as all the other Fords, except the K were runabouts or roadsters.

⁷³¹Quoted in *The Argus*, August 23, 1908. The *Ford Times* article is in vol. 1, no. 9, August 15, 1908, p. 16.

Ford Times September 1, 1908, edition includes a two-page editorial column credited to Weeber, "who has been a very successful Ford dealer in that [Albany] territory." The article is reprinted here in its entirety. It's likely that editor H. B. Harper had interviewed Weeber on the latter's 1908 trip to Detroit. In the same issue, in a separate column, Harper or a colleague in asking for contributions from other Ford sellers, said, "we do not ask you to write a polished story of several thousand words. Mr. Weeber could, probably, have written as good an articles as we did, but he was too busy to more than outline the points. You give us the hints and we will endeavor to so write it as to correctly convey your ideas and not disgrace you as an author." With that introduction, the *Ford Times* article follows here, likely in a paraphrase of Christian Weeber's words but nevertheless a means to learning his, or perhaps Harper's, sales experiences and techniques.

Securing Prospects

No matter how many possible buyers you have in your territory your sales will be small unless you devise some means of impressing those prospects with the advantages of the Ford car and create in them the desire to own a FORD. They already have a desire to own an automobile; it's up to you to direct their thoughts from the general idea to the specific car you have to sell. Make them think Ford instead of automobile.

To do this means work, cost money and takes time, but it pays. In order to stimulate a Ford desire in the minds of all the possible prospects in my city, I first ADVERTISE. The daily papers will carry your name into every home. It's your introduction as it were. How to advertise is too broad a subject to discuss here, but there's an advertising department at the factory whose manager is paid to assist you. Call on him for copy and suggestions. The FORD TIMES, too, will often contribute an idea that you can utilize. From this advertising you will secure some direct inquiries. On these you bend all your selling energies for every sale consummated helps another sale—when you are selling Fords.

Always make it a point to ask each buyer, as a favor, to suggest some neighbor or friend who in his opinion might be sold. I have noticed that if Jones buys, Jones has a friend who thinks that if Jones can afford a car, guesses he can and tells Jones that if his car is all right, he

will buy one too. I can point to a number of sales made in just this way. Getting after the man "Jones" told me about.

Sometimes the man who pays for the car is not the one to be "sold." A recent sale demonstrated this point. A certain young lady had a young lady friend who drove a car and often invited the first young lady to accompany her. Now we all like "your riding" but the more we do it the more we want a car for ourselves. I had observed this non-owner riding with the owner and sought the first opportunity to demonstrate the Ford to her.

"Do you suppose I can learn to run this car?"

"Of course you can—simplest thing in the world."

And I traded seats and taught her how to run the car.

Then she informed me she "just knew papa would buy if he knew I knew how to run it."

Then I saw papa, a busy business man, and sold him the car for his daughter for "she already knew how to run it."

If two doctors live in the same block and one buys a car, I call the other by phone and offer to take him in my car to make his calls some afternoon. The very fact that his competitor owns a car helps me to eventually sell him.

If I sell a car to a man in a certain neighborhood, I immediately canvass that entire part of town for I know that this man has neighbors who will not permit him to get ahead of them. If Jones' wife brags to Smith's wife about their Ford car, Mrs. Smith gives Mr. Smith no rest until she too has a car in which to go shopping. She isn't going to allow that Jones woman to flaunt it over her.

Another scheme I have recently employed with success is that of going after the man who owns a big car. I can soon prove to him that he really needs a Ford just to save his expensive machine. You would be surprised how many wealthy owners are really anxious to cut down their car expense, and when I show them how by using the Ford 50% of the time it will actually pay its cost through the saving in gasoline, oil, tires, and repairs—be actually more convenient for use *that* 50% of the time and while paying for itself give the man an extra car for emergency.

To the man who is looking for sales, numerous ways will present themselves for getting next to people who can be sold if they can be started thinking Ford cars and how to make

them think is something circumstances control.⁷³²

1909 Model Year

An undated newspaper clip from the second half of 1909 reports that the C. F. Weeber Manufacturing Works was the Albany agency for Ford and Ohio cars and Chase trucks. "In the sale of these popular cars, a fine business has thus far been done and for the future the outlook is bright. The Ford car, for which Mr. Weeber is exclusive agent, in Albany, is one of the best and most popular cars in existence. . . ."⁷³³

The Weeber file of correspondence with the Ford Motor Company, both the factory and New York branch, contains only one item dated between the April 1908 and April 1909. Apparently this gap was represented by letters and telegrams not preserved, either by Christian Weeber or Marion Weeber Welsh, or lost in some fashion despite their efforts.

The Model T Ford cars finally were introduced in October 1908.⁷³⁴ By mid-month, Weeber was being forwarded the names of prospective customers interested in the new car. On October 19, for example, Leahy wrote that Ward Van De Bogart of Copake and William Wallace Darrow of the *Chatham Courier* in Chatham, should be contacted. The latter man, Darrow, was someone with whom Weeber was to have considerable interaction.⁷³⁵

One surmises that the Weeber service operation contributed a significant portion of the business' net income. However smooth running the repair shops, there were naturally difficulties. The incompetence of a shop supervisor has been mentioned above. There was, also, in October 1908, a minor fire, as a gasoline tank in an automobile blew up. *The Argus* reported:

(Bang! Siss! Boom! Fire!) Friday night caused great commotion in the block and called out the fire department. But the fire was out be-

⁷³²Vol. 1, no. 10, September 1, 1908, pp. 8-9. Also reprinted in *The Argus*, September 6, 1908.

⁷³³The loose, incomplete clipping came to the State Museum from Marion Weeber in May 1983.

⁷³⁴Kimes, *op cit.*, p. 575.

⁷³⁵Weeber noted on Leahy's letter that he "wrote 11/13." Darrow's name was crossed out in pencil.

fore the fire department reached it, and the automobile was but slightly damaged.⁷³⁶

In February 1909, Christian Weeber, "who has the Albany agency of the Ford motor cars," was reported "interested" in Henry Ford's effort to enforce patent rights for his invention of an automotive drive train (This is in distinction to the Selden patent affair in which the Ford Motor Company was an alleged infringer.). A story in *The Argus* reported that fifteen or twenty of the leading manufacturers might have been in violation of the drive shaft patent. Ford's efforts to enforce the patent allegedly were creating "more excitement among car manufacturers than they have known since the early days of the Senden [sic] suit."⁷³⁷

A Weeber Manufacturing Works advertisement in early April 1909 likely had content forwarded by the Ford Motor Company. The text claimed the Model T was worth buying since it was worth copying. "FIFTEEN TO TWENTY MANUFACTURERS of higher priced cars have been notified to cease infringing on the Ford patent system of final drive." The use of vanadium steel in the Ford, magneto ignition and a high power to weight ratio were other points touted. The low Model T prices with "NOTHING OVER A THOUSAND" (touring car at \$850; roadster at \$825; coupe at \$950; and town car "at an even thousand") were additional Ford advantages.⁷³⁸

It may have been mid-winter 1909 before Christian Weeber received Model T cars. On February 7, *The Argus* reported that the Weeber showrooms had the "1909 Ford car. . . on exhibition." Even as it offered "remarkable value and many few features which the Weeber Company is demonstrating," the car was in short supply. Weeber advertised the Model T in February ("Now on Exhibition") and March ("Best Automobile Value in the World").⁷³⁹ While reporting "a large spring sale with six styles of Ford cars,"⁷⁴⁰ in April 1909 Weeber wrote to Detroit to ask about what, apparently, he perceived

⁷³⁶October 10, 1908.

⁷³⁷*The Argus*, February 28, 1909. The reference, of course, was to the Selden suit.

⁷³⁸*Press-Knickerbocker-Express*, April 2, 1909; *Albany Evening Journal*, April 3, 1909.

⁷³⁹*Press-Knickerbocker-Express*, February 12, 1909; *The Sunday Press*, March 28, 1909. The former records the advertiser as the "C. F. Weeber Mfg. Works & Show Rooms."

⁷⁴⁰*The Argus*, April 4, 1909. On March 28, the paper had reported that the Weeber concern had "a commodious garage and represents the Ford car, making a specialty of the Ford

as delayed deliveries. H. B. Harper, assistant commercial manager, replied, saying that the matter had been referred to the New York Branch for more definitive information about shipments to Albany. In general, Harper said, he had Henry Ford's assurance that production in May would reach a capacity of 75 to 100 cars per day. The problem, he continued, had not been with shipments but with orders overwhelming the company's capacity to build cars. The "very large production which we have been able to keep up has seemed small as compared with the business." He concluded by saying the factory was doing all it could "to raise the rate of production and the consequent rapidity of shipment so that all of our dealers will have no cause to complain."⁷⁴¹

Weeber was not mollified. On May 7, after failing to reach Plaintiff by telephone, he wrote to Plaintiff at the New York Branch. The reply, dated May 8, suggests Plaintiff's regard for Weeber and his business. That letter, is quoted here in full.

My dear Mr. Weeber:

I am in receipt of your letter of the 7th and am very sorry that you think I am [sic] trying to dodge you on the phone. This is not so.

Mr. Couzens has been in town and I have been very busy with him regarding work on the outside, and have left a great many matters with Mr. Vanderpoel to be attended to.

It is not that I do not care to talk to you but there is nothing to say in reference to deliveries.

I appreciate your position thoroughly and know exactly how you feel, and I have instructed them to give you the benefit of shipments as much as possible. I don't expect the cars will commence to come through fast until this coming week, and then I imagine we will ship a great many.

I still believe we are going to do a tremendous business.

In reference to taking more orders, I will let you know about this sometime this coming week.

I don't see why our salesman should make such a statement to your customers, as we

runabout." The availability of the roadsters and a shortage of touring cars likely contributed to this specialization. See the main text regarding a June 1, 1909, letter from the New York Branch of the Ford Motor Company urging agents to steer potential touring car customers to roadsters.

⁷⁴¹Harper to C. F. Weeber Mfg. Works, April 28, 1909.

have no cars here but one coupe and a landaulette, and you can have these if you want them. Our salesroom looks more like a skating rink than an automobile show room.

Cannot give you any more definite information at the present time.

Very truly yours.⁷⁴²

Among several letters giving Weeber names of prospective customers, Plaintiff wrote on May 15, 1909, that he expected to ship him several cars in the coming week. He asked Weeber to

"Please take care of Mr. Ten Eyck...He certainly seems to want a Ford car very badly, and I imagine he would do a lot of good...Hope to ship you quite a few cars next week."⁷⁴³

On May 22, Plaintiff wrote again, as the order situation had not yet stabilized.

I understand there is a carload of cars on the road to you, and hope from this time on, we will be able to ship you quite a few carloads each week; however, everything is so uncertain we do not want to make any promises at all.

Awfully sorry matters are in this condition, but it is not the writer's fault. I can only hope everything will turn out all right before the end of the season.

Hope to see you soon, with kind regards,

Apparently, Plaintiff's letter and one of Weeber's crossed, for on the 25th of May, Plaintiff wrote again. "Answering your letter of the 22nd beg to advise that it is impossible for me to tell you the exact number of cars you may expect but you can be sure we will do all we can for you." A surviving freight bill from the New York Central & Hudson River Railroad Company, dated May 22, 1909, includes shipment from Detroit to C. F. Weeber of three automobiles, three horns, three sets of tools, one top and nine lamps. In all, the 10,000 pound shipment cost Weeber \$56.

A letter signed by Vanderpoel on June 1, 1909, advised the "Weeber Mfg. Co." that the New York Branch car allotment for the coming month was going to consist of more roadsters than touring cars. The Weeber management was encouraged to "induce some of your touring car customers to change to roadsters." The Weeber firm was requested to

⁷⁴²Plaintiff to C. F. Weeber, May 8, 1909.

⁷⁴³Ten Eyck's first name is lacking in the correspondence.

Ford Motor Company

HENRY FORD, PRESIDENT
JOHN F. DODGE, VICE PRES.
JAMES COUZENS, SECRETARY

AUTOMOBILE MANUFACTURERS

WORKS AND OFFICE
PIQUETTE AND BEAUCHIEN STREETS

Detroit, U.S.A.

April
28th,
1909.

The C. F. Weeber Mfg. Works,
Albany,
N.Y.

Gentlemen:-

ALL STATEMENTS OR AGREEMENTS CONTAINED IN THIS LETTER ARE CONTINGENT ON STRIKES, ACCIDENTS, FIRES, OR ANY OTHER CAUSES BEYOND OUR CONTROL AND ALL CONTRACTS ARE SUBJECT TO APPROVAL BY THE SIGNATURE OF A DULY AUTHORIZED EXECUTIVE OFFICER OF THIS COMPANY. CLERICAL ERRORS SUBJECT TO CORRECTION.

We are in receipt of yours of the 24th regarding the question of deliveries, and have referred same to our New York Branch for attention, as they can advise you more definitely regarding shipments into Albany than we can from here. We can say that you may look for a considerable improvement in this matter of shipments now that Mr. Ford has put into operation the improvements he had in mind for this car, namely the thermo-siphon system of cooling, and we have his assurance that early in May the rate of production will have reached our capacity of from seventy-five to one-hundred cars per day.

I do not know if you appreciate that we have already delivered more Model "T" cars in the four months of 1909 than the Ford Motor Company ever built of any other model in the same four months of any other year. The trouble has not been with shipments, we have been making them fast enough, but the orders that have been received have been so greatly in excess of our expectations that the very large production which we have been able to keep up has seemed small as compared with the business. You can rest assured that we are doing all that can possibly be done to raise the rate of production and the consequent rapidity of shipment so that all of our dealers will have no cause to complain.

Yours very truly,

FORD MOTOR COMPANY

H. B. Harper
Asst. Commercial Manager.

HBH-AR

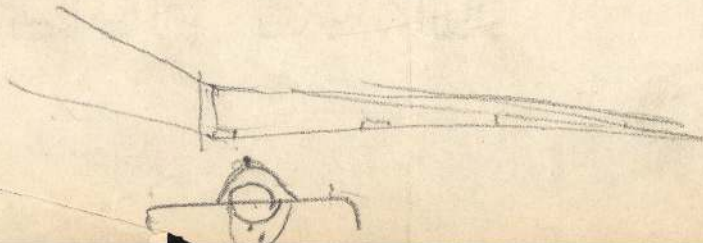

Figure 8.7: H. B. Harper letter to Weeber Mfg. Works, April 28, 1909 with what appears to be one of Christian Weeber's drawings on it. This two-part image is very similar to the sketches from the 1920s as Weeber worked on his helicopter. NYSM Collection, H-1933.6.NN.

respond with "what you may be able to do in this matter." Christian Weeber noted on the letter, "Write today."

One potential customer for a roadster was H. E. Blake of the New York State Department of Highways at Schroon Lake. He wrote to Weeber on June 23 to ask if the latter might be in a "position to guarantee the delivery of a Ford Model T roadster at any definite date in the near future." While Blake had not yet decided to buy, "if I could get one within a few days might decide to do so." Weeber noted on the Blake letter, "Write 6/29 copy."

On the same day, June 29, Blake wrote again:

On the 29th of May, last, I bought of you a model F Franklin car No. 1644 and I have your written agreement to take in the same at \$350 toward a Ford model T roadster should I desire to have you do so. I have decided to make this deal I would like to get the Ford at the earliest possible date at which you can deliver it to me.

If possible please let me know at once when you can make delivery, and if that is not possible then please let me know about when you think you can make delivery and oblige.⁷⁴⁴

Weeber finally received a broadcast letter from Detroit dated June 29, 1909: "To All Dealers Under Branches" advising that beginning July 6, the Ford Motor Company would be "ready to accept and enter orders" for delivery in early August of touring cars as well as "roadsters, town cars, landaulets and tourabouts." Each order was to be forwarded to the branch offices with a \$100 deposit and the name of the final customer. Shipments were to be made according to dates the orders were received. "The first orders in will be the first shipped." Production was to be about 450 cars a week.⁷⁴⁵ Plaintiff soon wrote to Weeber, advising him to get his "new orders for August" in "as early as possible

⁷⁴⁴H. E. Blake to C. F. Weeber, June 23, 1909 and June 29 1909. On the later letter, Weeber noted, "write 5/2 [sic] copy." Blake wrote on Department of Highway stationery. The Model F. Franklin was a light touring car. The serial number suggests Blake's machine was built in 1905.

⁷⁴⁵The letter was signed by the "Commercial Department." Dealers were urged to promote the sale of accessories such as tops, lamps windshields and speedometers. They also were requested to acknowledge the letter "direct to the Branch with whom you hold contract." A broadcast letter from the New York Branch addressed to C. F. Weeber and dated May 27, 1909, advised him that "instructions from the home office" indicated that "hereafter we can accept only currency or draft on a New York City Bank in payment for cars."

for it looks to me as though they are going to deliver orders in rotation."⁷⁴⁶

In early July, Weeber contacted the New York Branch requesting that the roadsters he had ordered be shipped in gray paint. Vanderpoel wrote that his organization had wired the factory with Weeber's wish. A telegram from the factory to the Weeber Mfg. Co. [sic] said, "More gray roadsters probably in week or ten days." Other telegrams in this period reported "Three roadsters shipped you yesterday" (May 7); "Carload being shipped next week" (June 12); and "Three touring shipped you fourteenth" (June 17).

One wonders if the desired roadsters (above) were Model S or Model T cars. Although the S was no longer current, Vanderpoel wrote to Weeber on September 11, 1909, to state that the New York Branch had three S Roadsters on which the list price had been cut from \$750 to \$700. "We had such numerous requests for this model, although we had sold all of our last year's output, that the factory made up a few additional cars." It should be remembered that Weeber had enjoyed sales success with the S.

A letter from Plaintiff dated July 19, told Weeber, and probably every other Ford dealer doing business with the New York Branch, three weeks of the August production "has already been sold and contracted for, with a deposit on each car." Agents were advised to order cars for August and September "at once." Weeber noted that he "Called & arranged matter 7/22."

A circular letter to "all dealers and sub-dealers" dated July 28, reported that now all of August's production had been contracted for as well as a "large portion of September." The dealers were advised to "place your orders and deposits AT ONCE" for September deliveries. The same day, Vanderpoel wrote Weeber that three cars already ordered had been changed from "tourabouts" to touring cars "as requested." Remittance for cars 12795, 12796 and 12797, with "new style" tops, was

⁷⁴⁶Plaintiff to C. F. Weeber, July 1, 1909. Weeber had written Plaintiff on June 29 to complain about C.O.D. shipments and Plaintiff's letter focused chiefly on that subject. He wrote, "This is indeed a mistake and nothing else because the writer never gave instruction to C.O.D. you since he has been in the place. I don't believe you will be bothered from this time on, but if you do there will be some trouble around the office."

to be received during the week of August 8, i.e., delivery was expected at that time.⁷⁴⁷

In late June 1909, Silas M. Smith, a carriage manufacturer, blacksmith and agricultural implement dealer in North Germantown, wrote to the Ford Motor Company in New York. He asked if there were no Ford agent in his town, for the "best Prices and Discount to the trade you have to offer on the first Sample Car and how [long] it would take you to fill first order on Sample Car." Vanderpoel forwarded Smith's letter to Weeber, informing the latter that Smith had been mailed a 1909 catalogue. Weeber contacted Smith, who in reply asked for Weeber's "best prices on a Sample Model T Touring Car with top and no Top with Sirch [sic] Light." Smith wrote again soon after, noting that he had cash prices in mind. After hearing from Weeber once more, Smith wrote on July 15, 1909 to state:

My Customer has lertn [sic] that you ar [sic] futhing [?] only A new Car 1910 and he wants prices on this befor [sic] he gives eny [sic] order if have eny cuts of this Car send me one and name prices for Same and the [?] Discount to me he claims you have price to [sic] high Can you do any better on Top and lights Am very anxious to sell this customer he is a man of good influence and will be able to help in Scuring [sic] more on his [?] and being at [sic] old customer of mine I would like to favor him all I can

Due I understand this correct \$935 with Top I will receive [sic] 5% on the first Sale. And ten with rebate of 5% on Second Car is the \$935 F.O.B. Factory or Albany⁷⁴⁸

In August 1909, a Ford and Mitchell dealer in Plattsburgh, Langlois and Company, corresponded with the "C. F. Weber Mfg. Wks.," regarding two cars for which Langlois hoped to have customers. In one letter, "H.J.L." said he was "unable to locate either of the two prospects by phone or in person. It is now 8.30 p.m. and will try to get in touch with them some time later tonight." In another letter, dated "226/09" [sic], Langlois said [He] "was unable to land customer today,

⁷⁴⁷A. C. Vanderpoel to C. F. Weeber, July 28, 1909. Weeber's order date was July 8. Terms were to be "S/D/B/L," i.e., sight draft bill of lading.

⁷⁴⁸Smith to Ford Motor Company, June 28, 1909. Vanderpoel to Weeber, June 29, 1909. Smith to C. F. Weeber Works, July 5, 1909. Smith to C. F. Weeber Mfg. Works, July 7, 1909 and July 15, 1909.

but may be able to agree tomorrow. I had originally arranged to drive the car up from Albany thus saving the \$36 freight Alb. – Plg. [Albany to Plattsburgh] but he did not want to chance driving during unfavorable weather. Only way out now is to get another prospect and get two cars shipped. Will let you know by noon over telephone sure, Friday."

Whether any cars were sold to Langlois is undocumented here. On the other hand, the Elmer Automobile Company in Hartford, Connecticut, wrote to "Mr. Weber" on September 19, 1909, asking, "Can you use two touring cars or two runabouts? Same arrived this week. Wire at once if you want any of them."⁷⁴⁹ At some point, likely in 1909, Frank Bowen on New York Branch of the Ford Motor Company stationery, wrote to C. F. Weeber that the car he had "wired you about is one I sold myself and is in fine running order. . . ." Bowen apparently wished to move the car to Weeber, estimating it would take two days to put it "in perfect shape to go on the road." Obviously not a shaft-drive Ford, the car had new chains and sprockets. "I am getting it at the price quoted because of friendship. Cars of this model are selling in New York at the present time for \$1,500."⁷⁵⁰

B. J. McDonald, a stove dealer in Schenectady, wrote to "Mr. Weeber" on August 16, 1909, to propose trading his Pierce-Arrow for a "light touring car. I would prefer a Ford." His Pierce tourer was in "A-1 condition just been repainted." He asked Weeber to let him know "if you are in for a deal." Weeber noted in pencil on McDonald's letter, "write what type, number of cylinders & year made & at what price you are holding" as well as "wrote 8/26 copy," the last indicating he wanted to have a copy of the outgoing letter.⁷⁵¹ McDonald responded in a letter on September 13.

I was over to your place yesterday and you was locked up and I telephoned at your house but could not get you in regard to the automobile that I have to trade with you is a

⁷⁴⁹¹¹⁵Pencil notations record, "write" and "9/2."

⁷⁵⁰Weeber drew a pencil oval on the Bowen letter. How he responded otherwise, if at all, is unknown here. In this period, mid-1909, Weeber purchased one or more used Thomas chain-drive cars as has been discussed earlier in this book.

⁷⁵¹McDonald to Weeber, August 16, 1909. McDonald's letterhead indicates he was at 742 Albany Street as well as 301 Page Street. Weeber's brother Louis, it will be remembered, had a butcher shop on Albany Street.

pierce arrow 1905 2 cilendar [sic] design engine I have overhauled it last winter put new gears in transmission and dif gears also new piston rings and had it repainted with a first class job the upholsed [sic] is fine shape tires in good shape and clock on tire holders extra tubes. 3 of them. Please let me know at once it has 20 horsepower yours truly⁷⁵²

On August 23, 1909, Frank W. Palmer of Blue Spring Farm at New Baltimore Station, wrote the Ford Motor Company in Detroit to say he was "somewhat interested in your car and I would like the Story of your trip from Ocean to Ocean and any other literature that you have on the subject." Someone noted on Palmer's letter that "Literature Sent." Weeber added, "Wrote 9/8 CFW." A cover letter from the Ford Company to C. F. Weeber suggested that he "get in touch with this gentleman and see what can be done to effect a sale." Weeber added in pencil, "Wrote to Mr. Palmer."

Two Model T cars were the Ford Motor Company's entries in the "Ocean to Ocean," New York to Seattle, automobile endurance contest. Part race and part road rally, the event had only six entries. While one of the Fords was the first car to reach Seattle, some five months later it was disqualified for an illegal engine change enroute and first place was awarded to the Shawmut entry. By then, the Ford Company had benefited greatly by advertising the performance of the lightweight Ford cars against much heavier and more expensive machines. H. B. Harper, the Ford advertising manager who served as co-driver on one Ford car, had written an account of the race, which likely is the publication Frank Palmer requested.⁷⁵³ During the period of uncertainty following the Shawmut Company's claim that the quicker Ford should be disqualified, Plaintiff wrote to Weeber. Since the contest had taken the competitors through Albany, he asked if Weeber knew of "any violations made by this [Shawmut] car and its crew." Weeber responded by letter but the content of his reply is unknown here.⁷⁵⁴ The C. F. Weeber Manufacturing

Works capitalized on the Fords' performance with a large display advertisement in *The Argus* praising the "Car That Won the New York to Seattle Contest." This, the advertising writer continued, was the "Same Model 'T' Ford that every buyer gets... the same \$850 4-cylinder... that beat those high-powered, high-priced heavyweight cars in a race too severe for 99 out of 100 of the cars at any price, on the market today."⁷⁵⁵ In another advertisement, the Weeber concern offered "the book 'Story of Race' which we will gladly mail on request."⁷⁵⁶

Among Ford Motor Company correspondence in the Weeber collection at the New York State Museum are letters regarding repair parts. L. J. Follett, writing from Saratoga Springs on Knights of Sherwood Forest letterhead on August 8, 1909, for example, asked if the Weeber Company could "send me a Brass Cap recommended by the Ford people to keep the oil from running out of [Model N] rear axle housing on to tires. The supply is too great and cannot cut it down with washers." Weeber noted on the letter, "Send one as soon as rec'd. Ans. 8/9/09" and "Sent 8/13."⁷⁵⁷ A month later, Weeber was looking for a new or second hand body for a Model K touring car. The Ford factory wrote from Detroit that it had "none of the same on hand." However, the New York Branch, in a separate communication written the same day, said it had a second hand "Ko6" body, i.e., 1906 model, which was available at \$40. In "splendid shape," the "only thing being against it is the style." In September 1909, when the Weeber Manufacturing Works ordered a 1908 Model K radiator to fit to a 1906 model car, the factory wrote to advise that a 1908 pump and "improved water connection" were needed, and that the company had "taken the liberty to add these latter to your requisition... If,

⁷⁵²McDonald to "Mr. Webber," September 13, 1909.

⁷⁵³For a history of the "Ocean to Ocean" event see Terrence M. Cole, "Ocean to Ocean by Model T Henry Ford and the 1909 Transcontinental Auto Contest," *Journal of Sport History*, vol. 18, no. 2 (Summer 1991), pp. 224-240.

⁷⁵⁴Plaintiff to C. F. Weeber, August 31, 1909. Weeber wrote on the letter, "wrote 9/3." A September 23, 1909, telegram from the Ford Motor Company in Detroit advised the "Weber Mfg Co." that "Ford car number two expect to pass through Al-

bany Sunday." A pencil note, apparently in Weeber's hand, states, "wire Mon. [?] a.m. 9/27." A second telegram from the Ford Motor Company in New York dated September 27, notes, "Car number two passed Albany last night."

⁷⁵⁵August 1, 1909.

⁷⁵⁶April 10, 1910.

⁷⁵⁷The remainder of the letter head is marked "Saratoga Conclave, No. 147, Uniformed Rank Foresters of America."



Figure 8.8: Photograph of Weeber Mfg. Works facility exterior with Fords and personnel, including Christian Weeber, c. 1909. Notable are the coupe model at left center and the Tourabout at right center. On the right of the photo is Emil Weeber's bicycle and motorcycle shop. It's probably Emil Weeber with his hand on the other side of the tree. NYSM Collection, H-1970.110.29.

for any reason, you cannot use them you may return them for credit.”⁷⁵⁸

In September 1909, Weeber received a request for Model T parts, a commutator brush assembly and a cylinder head outlet hose, from Scott D. Nichols. The letter requested that the parts be mailed at once “so we will get them by afternoon.” Pencil notations on the Nichols letter state, “Sent by Man 9/23 By B.”⁷⁵⁹ Nichols, as Ford agent in nearby Troy, was someone with whom the Weeber Manufacturing Works would have frequent dealings in the 1910 period.

Other repair business in the summer of 1909 is suggested by a copy of a letter from the Ford Company in Detroit to Ford owner Danforth Einsworth of Albany, who complained of oil fouling of the spark plugs in his car. The Ford writer, “R.E.B.,” advised the use of a “very light high fire test oil,” such as Standard Light Auto Oil. If that did not solve the problem, Einsworth was advised to have new pistons and rings installed by “Messrs Weeber & Co.” The only charge would be for labor. The defective parts would be exchanged for credit. A pencil notation on the letter documents \$3.25 for the “S.O. Co. of N.Y.” Another says, “Going to bring car over.”⁷⁶⁰

Also during the summer, a “tourist from Pittsfield” [Massachusetts] was “laid up with rear axle trouble.” Vanderpoel, in New York, advised the Weeber Company to “fix him up to the best of your ability, replacing all parts and looking to us for replacement in turn. Of course we can make no allowance for labor which you may put on car, and for which he should pay.”⁷⁶¹

In October 1909, Weeber wrote to Plaintiff directly by hand about a continuing problem a Ford owner had with his car.

In reference to our conversation on the stoop of the Ten Eyck Hotel regarding replacing engines, etc. Wish to say that...the man owning the coupe has had a very troublesome...factory engine, he has had nothing

⁷⁵⁸J. M. Donahue? [illegible?] to Weeber Mfg. Wks., September 9, 1909.

⁷⁵⁹Nichols to Weeber Mfg. Co., September 22, 1909. The letterhead is printed variously, “Rated Horse Power Is What You Read About—Actual Horse Power Is What I Sell,” “The Auto Man,” “The Old and Tried Out Kind at The Right Price” and “Don’t Experiment.”

⁷⁶⁰Ford Motor Company to Danforth Einsworth, September 20, 1909.

⁷⁶¹Vanderpoel to C. F. Weeber Mfgr. Co., July 15, 1909.

but trouble all last spring due to starting heating, etc. He is now starting to give us some trouble there is hardly a day that we must not go out to start his car in street or tow him in. We would like to see him get a new power plant of the Thermo System as we believe this will be the only means of keeping him contented to not sell his car, he has always been a loyal Ford owner, it will be to our interest to keep car on the street. If you wish to send the above it will need radiator also, as his...the old pattern as stated above. Hoping to hear from you favorably return mail I am...⁷⁶²

As assistant manager of the New York Branch of the Ford Motor Company, on September 1, 1909, a letter from Vanderpoel advised the C. F. Weeber Mfg. Works, in response to a query that “approximately the business done by you this year to date is thirty-two thousand (\$32,000) dollars.” Ten days later, W. R. Sampson wrote that the Weeber Mfg. Company account had owed \$468.65, “still unpaid” from a September 1 statement. Weeber noted in pencil that he wrote in reply on September 14, probably suggesting that he would settle his account on a visit to New York. Sampson responded on September 16, suggesting that, “if you can make your visit to this place about Sept. 20th, you will find this time very suitable for settling [sic] your account, as we expect to be very busy closing out our fiscal year the latter part of the month.”

Christian Weeber added another significant automobile line to his business toward the end of 1909. The Haynes cars, built by the Haynes Automobile Company of Kokomo, Indiana, were, at that point, more than three times as expensive as the Model T Fords. There was no competition between the two product lines for the same customers even after the Haynes prices were lowered significantly for the 1910 model year, the first for Weeber. There were, however, complications for Weeber when it came to representing the two manufacturers. These difficulties are delineated in the section dealing with Weeber as a Haynes dealer.

⁷⁶²C. F. Weeber to Gaston Plaintiff, October 20, 1909. The surviving document is a carbon of the handwritten letter. Several of the words are too faint to be read. The reference to the car owner is “Dr Sha...,” possibly Henry L. K. Shaw, an Albany physician. Or the man may have been William F. Shaw of Voorheesville. See the Haynes chapter of this work for discussion of a coupe built by Weeber for a Doctor Shaw on a Haynes chassis. Weeber’s proposal to replace the Ford engine with a thermo siphon type suggests the car in question was a very early Model T equipped with a water pump.

1910 Model Year

In early August 1909, the Weeber Manufacturing Works began to hear from the Ford Motor Company about the 1910 Model T line. Initial prices were set only for the \$1,050 coupes and \$1,100 landaulets. Dealers were advised that orders for those models only could be accepted for delivery after September 30, 1909, i.e., the end of the 1909 model year. On August 21, the Ford Commercial Department sent prices for the other cars, specifically \$950 for the touring cars and tourabouts; \$900 for roadsters; and \$1,200 for town cars. The open cars listed for \$75 less “unequipped” i.e., without an unlined top, windshield, two gas lamps and generator, two side oil lamps, tail lamp and horn.

On August 25, “W.B.D.” of the Commercial Department advised the Weeber Manufacturing Works that 300 Model T catalogues had been shipped, as requested in a letter dated two days earlier. Weeber noted in pencil, “Did you order 300 thought was 3 doz.” On September 22, “W.B.D.” wrote to the Weeber firm that 100 Model T “catalogs and envelopes for same” were being sent that day, “as requested in your letter of Sept. 17th.”

The Gifford-Wood Company of Hudson, manufacturers of conveying equipment, if not a Weeber sub-dealer for the 1909 model year likely was in the automobile business in some other capacity. A letter sent to the Weeber Company on September 17, 1909, while first noting that some requested Model S and T parts books had not yet been received, continued by stating that as far as the 1910 Model T was concerned:

... we do not care to do anything in the matter of taking the agency over for some time, therefore, it would not pay you to send a car down to have us look it over. We believed you fully understood our position in the matter as was talked over with your representative when he was down here the other day.⁷⁶³

The continuing success of the C. F. Weeber Manufacturing Works as a Ford dealership is suggested by the first prize of \$100 the company won in the automobile parade staged as part of the Hudson-Fulton Celebration in Albany in October 1909. The prize “for the greatest number of cars in line went to the “C. F. Weeber Manufacturing Co., [sic]

⁷⁶³The letter is signed with the initials “WMG.” Weeber drew a pencil oval and noted “wrote” on the sheet.

agents of the Ford machine.” What number of cars the Weeber firm supplied of the 227 total in the parade⁷⁶⁴ has not been determined here.

In January 1910, *The Argus*, noting that the Model T was a “great favorite in Albany, judging from recent sales,” retained a positive view of Christian Weeber’s business relationship with the Ford Motor Company.⁷⁶⁵ The Weeber Manufacturing Company advertised, “If you want one of these cars it will be best to get your order in now [January 1910] for spring delivery, as later it may mean a waiting list.”⁷⁶⁶

The joint Ford-Haynes exhibit at the first automobile show sponsored by the Albany Automobile Dealers Association held at the Washington Avenue Armory in February 1910. The Weeber exhibit included a display of four Fords, which by themselves were the “equal to many separate booths,” according to the *Albany Press-Knickerbocker* and *Albany Morning Express*. The vehicles included a touring car, a roadster, a town car “enclosed for four passengers” and a combination runabout and delivery car, which attracted “the most attention. It can be used as a pleasure vehicle and, with the seats removed, a business wagon. It is a type of car that is becoming popular for people who need cars for both purposes.”⁷⁶⁷

The newspaper’s description was that of the Ford Tourabout, the open vehicle resembling the touring car without rear doors. On the Tourabout, the rear seat could be removed allowing cargo to be placed on the flat floor behind the front seat. At the conclusion of the auto show, Christian Weeber suggested to the *Sunday Press* that the event be continued as the means of “... making this section one of the greatest auto centres [sic] in this country. We have made a number of sales during the show and among them is the purchase of a Ford run-

⁷⁶⁴*The Argus*, October 8, 1909. Second prize of \$75 went to the Locomobile agent, the Taylor Auto Company, “for the greatest value presented by any one make.” Third prize of \$25 was awarded for the exhibition of “a battle scarred Knox of the vintage of 1900.”

⁷⁶⁵January 30, 1910.

⁷⁶⁶*The Argus*, January 2, 1910. A display advertisement the previous November also advised buyers to “get you [sic] order in now for spring delivery, as later it may mean a waiting list.” See *The Argus*, November 21, 1909.

⁷⁶⁷February 11, 1910. The touring car was identified as a “30-horse power” machine, a probable error since all Model T cars, the only vehicles in the 1910 Ford line, had the same twenty-horsepower engine.

about by the Albany and Troy Amusement Company. The auto show should be an annual affair in Albany."⁷⁶⁸

In January 1910, Gaston Plantiff noted that the New York Branch of the Ford Motor Company, still at 1723 Broadway, had about fifty agents "in the territory which it controls." These agents were expected to extend courteous treatment "to every Ford owner under all conditions." With so many agencies under its supervision, it was impossible for the New York Branch to be in touch with each Ford owner. As far as possible, this was done by "a special corps of experts whose business it is to keep looking after the interests of our agents and their sub-agents."⁷⁶⁹ One of the agents, of course, was Christian Weeber.

In spite of his successes in selling Model T Fords, the 1910 selling season proved difficult for Christian Weeber as his relations with the Ford Motor Company became unpleasant and contentious. Although correspondence from Ford suggested Weeber should have sold more cars, invoices and order acknowledgements indicate a steady business (see Table 8.1 on the next page). A summary of the surviving purchase and order records follows. In all cases, the discount from the list prices for the C. F. Weeber organization was fifteen percent. Freight charges were additional.⁷⁷⁰

Interestingly, payment for some of these cars did not follow immediately upon their arrival in Albany. The three vehicles invoiced on May 14, 1910, apparently were paid two months later, since Weeber marked the invoice "Pd. July 26." The three cars billed on January 6, were paid on January 25. Those dated May 31 are marked in pencil, "Pd. & unloaded."

⁷⁶⁸Quoted in the issue for March 13, 1910. Weeber Manufacturing Works display advertisements for both Ford and Haynes cars appeared in the March 6 *Sunday Press* and the March 12 *Press-Knickerbocker-Express*. "Demonstration Gladly Given."

⁷⁶⁹Gaston Plantiff, "Meeting Competition," *Ford Times*, vol. 3, no. 7, January 1, 1910, p. 2.

⁷⁷⁰Seven letters to Weeber from the Ford Motor Company in January 1910 ask the buyers' names for cars numbered 6258, 6472, 6536, 6537, 6697, 8774, 8806, 8829, 9296 and 9764. The last two buyers, someone has noted on the incoming letters, were "Dr. W. E. Dietz" and "Dr. Graham" respectively. For the first number, someone has written on the Ford letter, "Cannot find anyone who... [illegible]... a Ford by that number." These serial numbers are from the 1909 model year.

On January 12, 1910, N. [Norval] A. Hawkins, Ford Commercial Manager, sent a form letter to C. F. Weeber asking about cars in his stock or in those of his sub-agents. A space filled in with the number seven indicated that Weeber was that many cars "behind now on your contract estimates." "Don't talk road conditions, weather conditions, crop conditions or any other conditions, but show yourself a hustler and dealer of keen business judgment by carrying a good stock of Ford cars at all times." Someone, apparently Hawkins, circled the "7" and drew a line to a handwritten postscript, "You ought to sell this many coupes in Albany—Send us your orders!"⁷⁷¹

Two days later Hawkins wrote again asking about the "coupe business."

It is might discouraging to the writer to note that our Albany Dealer has sold so few coupes to date, and we are just wondering if you are giving this car the attention you should...

If you have not already taken the matter up with every dealer in your territory who should be ordering out coupes now, please *GET RIGHT AFTER THEM*. Give your salesmen a "coupe talk" and let's see if we can't bring this coupe business [sic] up where it belongs.

You understand we look to our branches and larger dealers entirely to move these closed body jobs and we wish you would outline a strenuous campaign for coupe business [sic] especially, and report say next week Thursday, the 20th, just what your results have been to date.

We expect you will at least order a coupe demonstrator shipped at once.

Hawkins appended a note in his hand adding, "Ought to be a dozen T coupes in Albany. What's the matter, Weeber?"⁷⁷²

It's difficult to judge Weeber's response to this affront. Perhaps he was familiar enough with Hawkins not to be upset. In fairness to Weeber, one should note that the coupe was not a successful model. Total production has been estimated at only 47 for the 1909 fiscal year; 187 for 1910; and 45 for 1911. Comparable figures for the touring cars

⁷⁷¹Hawkins to Weeber, January 12, 1910. Hawkins had been commercial manager of the Ford Motor Company since 1907. See *The Horseless Age*, vol. 20, no. 23, December 4, 1907, p. 824.

⁷⁷²Hawkins to Weeber, January 14, 1910. The body of the letter was typed.

Table 8.1: Invoice records for Ford cars sold by Weeber in 1910.

Date	Model	Serial	Equipment	Record Type
January 6	Tourabout	14188 ^a	Full with Firestone tires	Invoice
January 6	Tourabout	13898	Full with Firestone tires	Invoice
January 6	Touring	14149	Full with Firestone tires	Invoice
February 14	Roadster		Lamps, generator, top, windshield, speedometer	Acknowledge
February 14	Town Car		Lamps	Acknowledge
March 19	Roadster	17893	Full with Diamond tires	Invoice
March 19	Touring	17860	Full with Diamond tires	Invoice
March 19	Touring	17884	Full with Diamond tires	Invoice
April 2	Touring	19417	Full with Diamond tires	Invoice
April 2	Touring	19407	Full with Diamond tires	Invoice
April 2	Touring	19428	Full with Diamond tires	Invoice
April 25	Touring	21773	Full with Diamond tires	Invoice
April 25	Touring	21831	Full with Diamond tires	Invoice
April 25	Roadster	21817	Full with Diamond tires	Invoice
April 28	Touring	22172	Full with Diamond tires	Invoice
April 28	Touring	22180	Full with Diamond tires	Invoice
April 28	Touring	22179	Full with Diamond tires	Invoice
May 5	Touring	23422	Full with Goodrich or Dia. tires	Invoice
May 5	Touring	23344	Full with Goodrich or Dia. tires	Invoice
May 5	Touring	23394	Full with Goodrich or Dia. tires	Invoice
May 14	Roadster	24551	Full with Goodrich tires	Invoice
May 14	Touring	24618	Full. Tires not specified	Invoice
May 14	Touring	24590	Full. Tires not specified	Invoice
May 31	Roadster	26472	Full with Goodrich tires	Invoice
May 31	Touring	26554	Full with Goodrich tires	Invoice
May 31	Touring	26552	Full with Goodrich tires	Invoice
July 2	Tourabout	23862	Full with Goodrich tires	Invoice

^aBruce W. McCalley, *Model T Ford: The Car that Changed the World* (Iola, Wisconsin: Krause Publications, 1994), pp. 485-488, lists production dates for serial numbers incorporating this and the following cars. The car with serial 14118 was built on December 30 or 31, 1909; 26554 was built on May 25, 26 or 27, 1910. Most, if not all, cars in this period were painted green.

are 7,728, 16,890 and 26,405 respectively.⁷⁷³ Weeber did buy at least one coupe, shown in a photograph in front of the C. F. Weeber Manufacturing Works facility. Hawkins' suggestion that a dozen such cars should have been on Albany's streets is far-fetched. Perhaps he was being pressured to move an unpopular line.

In March 1910, the "C. F. Weeber Mfg. Co." heard from Vanderpoel in a letter pointing to Weeber's contract to deliver 25 cars by the end of the month. By March 3, only nine cars had been sold to customers. Vanderpoel asked that Weeber forward orders for "such [train] carload orders as you desire direct this month, specifying models and dates on which they will be delivered, and any carload orders for your sub-agents which you have on file."

Vanderpoel continued by observing that demand for Fords in the southern and western United States threatened to make future timely deliveries in the East questionable. Weeber was encouraged to order all sixteen contracted cars immediately, even if he did not have customers for all. In return, he would:

Earn the gratitude of the representatives of the FORD MOTOR COMPANY at this branch, and we believe you would make the Home Office sit up and take notice of what Albany can do when she really gets started.

Awaiting the pleasure of your reply, accompanied by the above mentioned orders, we remain...⁷⁷⁴

A week later Weeber heard from Plaintiff, who noted Weeber was "way behind on orders according to your estimate." While this was not critical to the New York Branch, which could "dispose of practically everything we can get hold of," there was going to be "tremendous shortage of low price stuff this coming April, May and June." Plaintiff, also noted that the factory could "unload their entire product west of the Mississippi River" and continued by noting that "I want to see our best agents like you and several others protected and

⁷⁷³Kimes, pp.575-577. The 1910 figure combines touring cars and Tourabout models. The Model T Ford Club of America (www.mtfca.com/encyclo/fdsales.htm) reports coupe sales at 117 for calendar 1909; 132 for 1910; and 56 for 1911. For 1910, Tourabout sales were 532 and touring sales 16,399.

⁷⁷⁴Vanderpoel, as assistant branch manager, to C. F. Weeber Mfg. Co., March 3, 1910.

the only way this can be done is to send in your orders now."

This may seem like a jolly but it is the absolute truth. I only wish you could find time to go to the factory and convince yourself.

Do the best you can and get in as many carload orders as possible for March and April delivery.

Hoping to see you soon and with kind regards, I remain...⁷⁷⁵

During the next two weeks, Weeber apparently wrote to the New York Branch about the latter interfering with his relationship to the sub-agents in his territory. Plaintiff responded on March 24:

I suppose Mr. [M. A.] Enders [Jr.] has been up to see you by this time and has taken up and settled the matter referred to in your letter of the 19.th

Do not think for a minute that we are trying any sneak game. That is not our way of doing business, there is some misunderstanding somewhere, and you can rest assured we will take care of you.

It is not our intention to go over your head but we must have business from you [sic] territory.

I understand that you had a very fine show in Albany and I was sorry I was not there to see it, however, I hope you will do your share of business before the season is over.

With kind regards, I am...⁷⁷⁶

In April, the New York Branch of Ford Motor Company included C. F. Weeber among recipients of a mass mailing of a Ford letter and of a report from the Auto Directories Company, Inc. in New York City. Included was a listing of the automobiles registered in New York State during the week ending April 9, 1910. Fords were the leading make with 104 cars, a number the Ford letter stated was fourteen more "than has ever before been registered in this state in the similar period of time, in the History of the Industry." Weeber and the other

⁷⁷⁵Plaintiff to C. F. Weeber, March 10, 1910.

⁷⁷⁶Plaintiff (signed by "E.S.") to C. F. Weeber, March 24, 1910. "Mr. Enders" was M. A. Enders, head salesman at the New York Branch, who in 1910 was made branch manager in Cincinnati. See *Ford Times*, undated 1910 issue, p. 493. "For the last three years Mr. Enders has been the assistant to Manager Plaintiff in the selling end of the business at New York and it is due to Mr. Enders' ability as a salesman that many difficult sales have been pulled through for Ford."

mail recipients were advised that “it will be gratifying to you, as it is to us, when you remember the part you had in swelling this list.” Haynes cars, also sold by Weeber, accounted for eleven registrations during the week, tied for twenty-first place with Autocar.⁷⁷⁷

In May, Harper wrote from the “Foreign Department” in New York to point to the sales successes of Scott D. Nichols in Troy, compared to the less than glowing Weeber “Ford sales in your territory.” That Harper letter also gave Weeber the name of a potential customer.

As the coupe, the town car was a slow selling Model T the New York Branch of the Ford Company endeavored to promote during the 1910 season. In January, in a circular letter to Weeber sent under separate cover, Plaintiff said he was sending a “quantity of letters and town car circulars that we ask you to send out to all liverymen and every hotel in your territory.” Since Plaintiff had “quite a few [town cars] coming thru at this time,” he hoped that Weeber could “help us dispose of some of them.”⁷⁷⁸ At some point in the late winter or early spring, the Ford Motor Company forwarded to the Weeber Manufacturing Works a copy of a letter from a Memphis, Tennessee, Ford agent, W. S. Bruce & Company, praising Ford taxicabs sold by the Bruce firm, “perhaps more cars for livery service than [in] any other City in proportion to population. Some of the twelve cars sold in February and March 1909 had been run 24 hours a day with as many as four drivers on the cars during that time. You would really be astounded to know the service these cars gave.”⁷⁷⁹

Christian Weeber advertised the town car. Similar display ads in *The Argus* (February 13) and the *Sunday Press* (February 20) featured the \$2,000

⁷⁷⁷Ford Motor Company to C. F. Weeber, April 13, 1910. The list shows 1,155 cars sold during the week compared to 712 the same week a year previous. The two through five ranked makes and the number of each registered were Buick (81), Cadillac (76), Maxwell (73) and Chalmers (52). Altogether there were some 115 makes of gasoline and steam cars excluding twelve makes of foreign cars (34 vehicles) and 18 dealer registrations (probably for demonstrator cars). Also excluded were nine makes of electric cars representing sixteen units. Studebaker, sold by Weeber beginning in 1910, accounted for eight cars registered during the reporting week.

⁷⁷⁸Plaintiff to C. F. Weeber, January 28, 1910. The signature is a rubber stamp.

⁷⁷⁹The letter, dated February 23, 1910, was signed by “Wm. G. Bruce, manager.”

Haynes Model 19 touring car as well as the Ford town car, which was “[j]ust the car for family or business use in good or stormy weather, and you will have all these conveniences for only \$1,200 WITH EXTRA TOURING BODY, \$1,350.”

There were no Albany customers for the car with or without the extra body. In April, Weeber wrote Plaintiff that he had “on hand a town car that we ordered for show purposes . . . find we will not have any sales for . . . up here.” He proposed exchanging it for a touring car or roadster. “We are willing to pay chgs. to N.Y. We think you can sell them much easier in N.Y.”⁷⁸⁰ Plaintiff, likely writing about the same vehicle ordered in February in response to his urging, said that at that point in April he could not take the car. He did advise Vanderpoel to have it shipped “from your place at once” should the Branch receive an order for such a vehicle. “Hope to be in your section next week and will call upon you as I have been wanting to have a long talk with you. We are very much pleased with the way you are getting along and hope the good work continues.”⁷⁸¹

It is likely that Plaintiff met with Weeber in Albany as he hoped. In early June, *The Horseless Age* noted that Plaintiff had returned to “the metropolis . . . after having covered a large territory in a trip through his district in a Ford car, visiting various agents almost as far north as the Canadian border.”⁷⁸²

Weeber’s sub-agents may have provided his Manufacturing Works with income during the 1910 model year but there certainly were difficulties as well. In June 1910, Enders, of the New York Branch, wrote Weeber asking him to sign “a new set of contracts in favor of W. D. Larkin, Averill Park, New York.” Weeber also was requested to have Larkin forward “his check for \$100 to apply on same.” “We regret that we found it necessary to do this work all over again but the contracts were not presentable enough for our approval. We are glad that you have someone working for you

⁷⁸⁰C. F. Weeber to Gaston Plaintiff, April 2, 1910. The surviving document is a carbon copy of Weeber’s handwritten letter, some of which is illegible.

⁷⁸¹Plaintiff to C. F. Weeber, April 8, 1910. Kimes notes town car production as 236 for 1909; 377 for 1910; and 315 for 1911. The Model T Ford Club of America, *op cit.*, reports town car sales for calendar 1909 at 284; 304 for 1910; and 337 for 1911.

⁷⁸²June 8, 1910, vol. 25, no. 23.

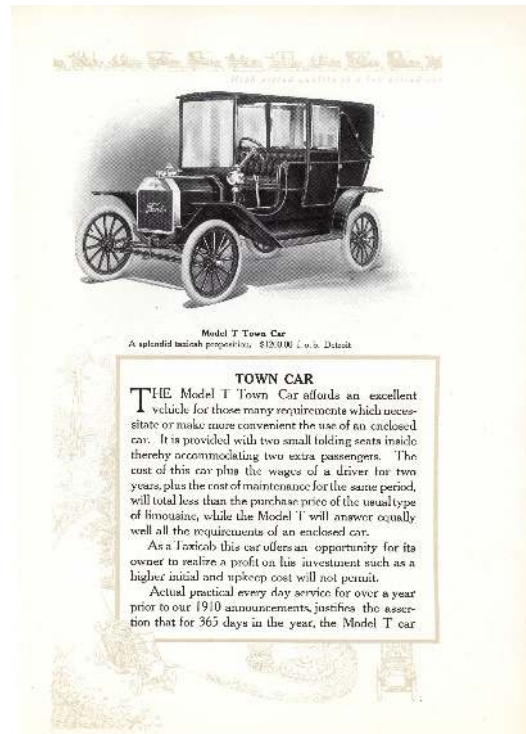
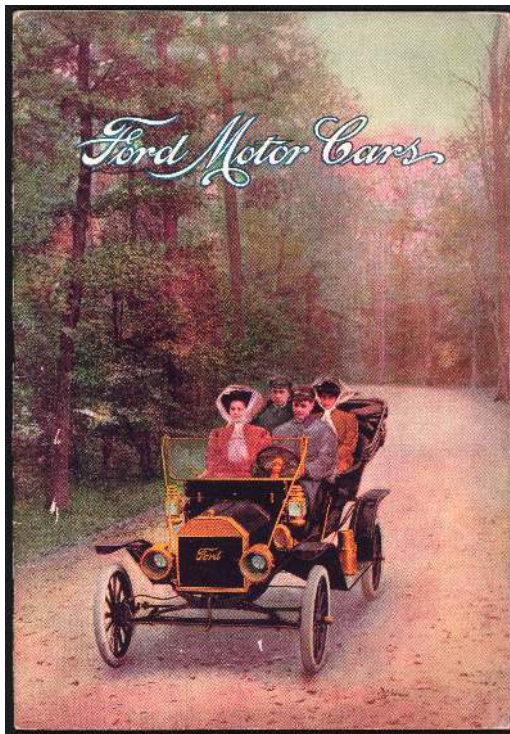

Figure 8.9: Ford Motor Cars Catalogue, 1910. Polychrome cover (unusual for 1910 period) and page describing the Ford town car (“splendid taxicab proposition”). NYSM Collection, H-2000.39.87.

in this section, as you certainly need them to help you out.”⁷⁸³

As noted previously, for the 1908 model year, if not earlier, Schoharie was part of the selling territory of the Heller-Spawn Motor Car Company and its successors of Binghamton. A letter from the Ford Motor Company in New York to Irving Posson in November 1909, accompanied by “contracts in triplicate for Schoharie and vicinity in Schoharie County, N.Y.,” calling for the delivery of six cars, attests to his appointment as a sub-agent. “We are in a position to make immediate deliveries on all models and you may go ahead and take orders for early deliveries just as fast as you like.”⁷⁸⁴

A few months later, in 1910 when Fayette Spawn remained the Ford dealer in Binghamton,⁷⁸⁵ Pos-

son apparently thought control of the selling territory where he lived was in Christian Weeber’s hands. Noting that N. S. and L. J. Wright in Schoharie were advertising the sale of Ford cars, in April Posson wrote to “Mr. Weeber:”

This Mr. Wright said the Ford auto ever since I have been trying to drum up a trade was nothing but a toy for in the parlor for children to play with now I can prove he said this now they have forbid me to try and sell a auto here or they would take the commission now let me know as soon as possible if they have got the agent to sell them.

Yours truly,

Irving Posson

P.S. My wife & Helen send their best wishes to Mrs. Weeber & Marion.⁷⁸⁶

⁷⁸³Enders to C. F. Weeber, June 21, 1910.

⁷⁸⁴M. A. Enders, Jr., to I. Posson, November 19, 1909. How Weeber came into possession of this letter is unknown here.

⁷⁸⁵The 1910 Binghamton directory shows Fayette E. Spawn as manager of the Spawn Auto Supply at 25 Henry Street; Lewis L. Heller, who in 1909 had operated the garage at 205 Water Street, had died. *Ford Times* for November 1, 1909, printed a short obituary, noting the passing “of one of our highly regarded dealers, Mr. L. L. Heller of Binghamton, N.Y.” He was “in the hustle every minute and possessed a personality that endeared him to his many friends.” The March 15,

1910, *Ford Times* has a photo of “a big winter order, this one from Binghamton, [sic] N.Y. F. E. Spawn, Binghamton [sic] dealer is shown...” with seven cars in front of his business establishment. The 1911 directory shows Fay E. Spawn as manager of the Binghamton Ford Sales Company at 205 Water Street.

⁷⁸⁶Posson to “Mr. Weeber,” April 10, 1910. Spelling, grammar and punctuation reproduced as written by Posson. To the Posson letter has been clipped a display advertisement for the Ford sold by “N.S. & L.J. Wright, Agents.” The car is described as “superior to all other manufactured to climb hills, muddy

Weeber noted in pencil on Posson's letter, "Wrote 4/14 no copy," so his comments on the situation in Schoharie apparently are lost.



President of the Chatham Courier Company, J. Wallace Darrow, as principal in J. W. Darrow & Son in 1910 was a Ford sub-agent to Christian Weeber. In late March of that year, Weeber wrote to Darrow asking if also he might wish to sell Haynes cars. Darrow's response was that:

... I could not well take on the Haynes, that is if it required me to purchase a demonstrator car. I could do this, I suppose, run a paragraph in connection with the Ford adv. (if agreeable to Mr Enders) announcing agency for.

... Send me some Haynes catalogs.

P.S. I think possibly Mr Enders will make an exhibit of Fords at our county fair here first week in September (20,000 people here last day) and you could send down one or two Haynes cars.

Darrow also asked about a (Ford) touring car. "When do you expect the [railroad] car in which brings my touring car?"⁷⁸⁷

Also in March 1910, Howard P. Hess wrote to Weeber from Valatie enclosing a J. W. Darrow & Son newspaper advertisement for Ford automobiles. Hess' letterhead was printed "Peter Hess Hardware, Heating, Plumbing... Automobile Supplies All Kinds of Repairing Promptly Done." Hess noted that the advertisement "appeared in a paper that is published in this town," i.e., Darrow's own newspaper. "You will note this party is selling below the regular prices. I did not think the Ford Co. would establish a direct agent so near you. I understand he is buying direct."

Weeber noted on the Hess letter, "Ans. 3/27 Copy" indicating, the author presumes, that he wanted a copy made of his reply. Of course, Darrow was Weeber's sub-agent. The Darrow adver-

and sandy hills... The guidance of the car can be made from a walk to 50 miles an hour without removing hand from steering wheel." This certainly does not describe a parlor toy.

⁷⁸⁷Darrow to C. F. Weeber Mfg. Co., March 26, 1910. The *Chatham Courier* continued as a Columbia County newspaper. Enders was associated with the New York Branch of the Ford Motor Company. Plaintiff refers to Enders in a letter to Weeber dated March 24, 1910. *Ford Times* for January 15, 1909, notes that, "Mr. Enders [sold] a coupe just before the lights went out on the [New York automobile show] closing night."

tisement stated that "our territory includes Valatie and Kinderhook and vicinity." And the advertised prices, \$950 for the touring car and \$900 for the roadster, both with "full equipment," were the regular Ford prices. In short, Hess had no legitimate complaint unless Darrow was receiving cars from sources other than Weeber and this doesn't seem to have been the case.

Darrow and Son display advertisements actually appeared in two issues of the weekly *Courier*. The text was identical in the March 16 and 23, 1910 issues. While it was the former ad that Hess forwarded to Christian Weeber, the latter added a cut of a Model T roadster. Readers were advised that "Demonstrations [would be] Given After April 1;" a statement suggesting that the Darrow sub-agency was a new one awaiting its first auto, probably the touring car to which Darrow referred in his March 26 letter.

In May, Weeber wrote to Darrow apparently thanking him for a note with leads to potential buyers. "Will get after the parties in question. Many thanks for same." Weeber continued by asking, "How soon do you expect you will need cars? Please let us know prospects by return mail." Darrow replied on the same sheet of stationery, under Weeber's penciled signature, that "I have two or three on edge as buyers but can't get them to come to a decision. Have given several demonstrations & all are pleased. Next thing is to get them to place an order."⁷⁸⁸

In June Darrow wrote several times about Ford sales. On the ninth he told Weeber he would "try to get some one to take delivery of car as soon as possible." On the 28th he wrote no fewer than three times. In a typed note to "C. F. Webber," Darrow responded to a letter informing him of the imminent delivery of a car. Darrow replied by saying that the original arrangement was for a July 10 delivery to a customer.

I will again bring the matter of taking the car before July 10, to the attention of the purchaser. I have no money to advance to take the car. ... You say that it is our place to take the car as soon as it is received. No, not if the order was placed for a certain date as in this case, July 10.

⁷⁸⁸C. F. Weeber to J. W. Darrow, May 5, 1910. The undated reply is signed "Darrow." The advertisement sent to Weeber with the Howard P. Hess letter said that, "Demonstrations [of Ford cars by Darrow] given after April 1" [1910].

Apparently addressing another matter in his same letter, Darrow noted that Mark Soule of Chatham had called on Weeber on June 27, when Weeber “made him a proposition on a Ford car.” Soule subsequently mentioned this to Darrow, who wrote to Weeber:

I shall expect my commission on this car the same as if he placed the order with me. What arrangements you have made with him is nothing to me. He is a customer of mine. I have given him demonstrations and talked with him on several occasions. Let me know if this is your intention.

A handwritten note followed in which Darrow reported that “the party Mark Soule has bought a Jackson of the Kinderhook agent... [remainder illegible]”

The third June 28 letter concerned the customer expecting a July 10 delivery. The purchaser had offered to give Weeber:

...a 30-day note which you can use at the bank and take car now. The reason for specifying July 10 was because he is to have some money paid him then. He is perfectly good. Is head of the Charles [?] Ghent Co. doing our ... [illegible?]... business. Let me know by phone on receipt of this if you want to... [illegible?]... I understand you have some... [illegible?]... cars just in. I want him to have one of these, not the one you offered to Mark Soule yesterday. When shall I send up for it? Can we get it Monday [?] or Tuesday?

The next day, Darrow wrote again to tell Weeber:

Mr. Woodward, the party buying, says he will pay discount on note if you want it. It's not up to me to do anything about it until time arrives when car was to be delivered viz July 10. Anything earlier than that is up to you. I don't care whether party takes machine before July 10 or not. If you want the note [?] party to pay discount, you can have it and he will take car next week. He is to be away rest of this week.

One additional, handwritten letter on *Chatham Courier* letterhead survives in the Weeber collection. On September 23, Darrow wrote to say, “I need the money by middle of next week sent [?] as my daughter leaves for school Saturday. Deduct what I owe you. You know I had to pay freight on the Woodward car or couldn't have made sale.” Weeber noted in pencil on Darrow's letter, “Sent Check.”

On July 12, 1910, Weeber wrote by hand to W. P. Fiero, Jr. in Springfield, Massachusetts, who “had called the 5th looking for a 1910... [illegible?]... Ford T.” Weeber noted that he had a T “that has been standing in one of our local subagt. [subagent] show rooms for several months & has not been used over 150 miles...” It could “not be told from new.” In fact, it might even have been better “as it has just been limbered up. We are willing to quote you this car delivered at Albany at [\$]875.00, a... price \$100 less than the standard delivered priced here. Fiero was invited to go to [the] place to look over & ride in it. This price is rock & can not accept any less as all we are looking for is at cost to us.”⁷⁸⁹ Fiero likely was William P. Fiero, Jr. (1874-1925) of White Plains. Weeber wrote to Fiero at the “Haynes House” (actually the Haynes Hotel) in Springfield, probably a temporary address. A newspaper obituary for Fiero noted he had been in the automobile business “practically all his life”.⁷⁹⁰

J. K. Barringer, a farm machinery dealer and perhaps a Weeber sub-agent in Castleton, wrote to Weeber in October about the repair of his car and the possible sale of another. The present author assumes all the vehicles in question were Fords.

You can't imagine how much better my car runs since you fixed the coil. It dont seem if ever has run as it does now. Do you suppose that could have been weak from the start as it does pick up so quick now. I drove down to see Mr Herrick the other day. I think he is more in favor of the car than I ever saw him before. I dont think it would have been any trouble to have [?] sold him this car if Mr Baker had not had that trouble with his. That made him a little afraid. I did not know what his trouble was at that time. I hope you may sell him one yet. Will do all I can for you.⁷⁹¹

⁷⁸⁹A carbon copy of the letter is part of the Weeber collection at the New York State Museum. Punctuation is as in the original.

⁷⁹⁰Catherine F. Gair, *Collection of Fiero Family Histories and Genealogies* (Hardscrabble Press: Berrien Springs, Michigan, 1983), p. 87. The Gair book has no mention of James N. Fiero nor of Maude G. Fiero, erstwhile father-in-law and wife respectively, of Fletcher W. Battershall mentioned elsewhere in this Weeber biography.

⁷⁹¹J. K. Barringer to C. W. [sic] Weeber, October 12, 1910. The handwritten letter is partially illegible. Weeber noted on it “ans. 10/25 no Copie” [?].

In October 1910, as Christian Weeber was making the transition from selling Ford Motor Company cars to selling the products of the Studebaker Brothers Company, he received a letter from C. A. Shadick in Nassau, Rensselaer County. Shadick, who perhaps coincidentally sold Studebaker cars as well as carriages, wagons and harness, asked Weeber:

What will you give me off on your Ford Cars on a Sub Agent base I have Three who wants cars now If you will give me a right discount I will sell them Let me know with out fail at once as they are all in the right shape to land.⁷⁹²

Weeber marked Shadick's letter with "Called 1/18."

G. E. Ward of Ravena, treasurer of the Ward Coal & Fruit Company, was a Weeber sub-agent. In a letter to Weeber in June 1909, Ward wrote:

The bearer of this letter Dr. Lester, is located at Indian Fields, eight miles west from here [Ravena] in our section. The writer was out to his place this morning with the Ford, and he was just getting ready to go up to look at some automobiles. I think he ought to have a Ford. Trust you will try and make him think so too.⁷⁹³

A month later, Ward wrote to Weeber enclosing a check for \$800 for the "Phillip's machine" with the promise to give Weeber a check for the balance the next day since Ward was going to be in Albany "probably by nine o'clock, and I would like my carbomotor [sic] fixed and anything else that needs attention on my machine. I am willing to leave it there all day tomorrow if necessary."

Of the deal with Phillips, Ward advised Weeber to bill for the car and accessories:

...at regular price, and he will pay that amount to me and you can give me credit on my account for my commission, also render me a bill for the commission. Phillips wants his top, lamps and generator, same as I have,

⁷⁹²Shadick to C. F. Weeber Mfg. Works, October 17, 1910.

⁷⁹³G. E. Ward to C. F. Weeber, June 3, 1909. Indian Fields was a hamlet destroyed by the construction of the Alcove Reservoir, part of the Albany city water system. Kollé, *op cit.*, p. 204, lists Whittlesey D. Lester, born 1875 in Brooklyn and an 1899 graduate of the Albany Medical College. His practice and residence in 1913 were at Indian Fields.

put on tomorrow complete and no doubt he will want some other extras.

Of his own car troubles, Ward wrote:

I had a nice time with it yesterday out in the woods, but I managed to get it a going after I gave it a rest. If any piece of machinery ever needed a rest I believe it was that carbomotor. Yesterday I worked on it two hours before dinner and could not budge it. Left it an hour, after dinner, and started first crank.⁷⁹⁴

In September 1910, in another Ward letter complaining about the cost of 115 repair hours on Ward's car in Weeber's shop and of a persistent ignition problem, Ward wrote, "I have had extra work done on it to make it like a demonstrating car as much as possible to demonstrate the durability of the Ford." A month later, Ward was looking for a spring, a box of carbide and a rubber gasket for the generator. There was no mention of Ford sales.⁷⁹⁵

Throughout much of 1910, the Weeber Manufacturing Works carried on extensive correspondence with the Ford Motor Company regarding full and partial credit for defective parts. In February, the Ford New York Branch distributed a four-page memorandum listing the allowances for various types of defective equipment. Beyond the basic ninety-day warranty, many replacement parts were sold at half-price for service of less than one year. Worn-out parts or those deteriorated by neglect, e.g., lack of lubrication, did not qualify for half-price replacement.⁷⁹⁶

In spite of the listings, the Weeber firm still had difficulties in deciding which parts were worthy of half-price or full cost free replacement. Apparently someone at the Weeber Manufacturing Works was careless in attaching car serial numbers to parts being returned to the factory. In June 1910, for example, "AAV" of the Repair Department wrote to tell the Weeber Company that cars 3350 and 4106 had been shipped to Boston and Cleveland respectively, while car 75303 "has not as yet been manufactured." The Weeber firm responded about the first car, which A.A.V. repeated

⁷⁹⁴Ward to C. F. Weeber, July 15, 1909.

⁷⁹⁵Ward to C. F. Weeber, September 19, 1910; October 19, 1910. On the latter letter Weeber noted, "wrote for check 10/2.5"

⁷⁹⁶Vanderpoel to C. F. Weeber, February 19, 1910.

had been consigned to the Boston Branch on June 15 and "is now in the hands of a private owner in the State of Rhode Island. We can, however, apply a credit against this car number but this low number would take the minimum amount of credit and for that reason, also to have our records correct we would be glad to have you ascertain the exact car number." A.A.V. did acknowledge that 4106 should have been 4107 "and we will issue credit for these parts accordingly." On July 26, A.A.V. wrote to the Weeber Manufacturing Works in response to the request of the return of Model S drive shaft and differential parts, for which, apparently, no credit had been allowed. A.A.V. declined to send the parts back because they "have been greatly worn and are, therefore, unfit for further use, and we do not think it would be a good policy to install them in any of our cars as it would surely break up the entire differential eventually." Instead, the Ford Company planned to "allow you a liberal allowance for the junk value of same, which we trust is acceptable. . . . Our credit goes forward immediately through the New York Branch, and we trust that it will reach you in due time."⁷⁹⁷



As late as August 1910, Weeber received "a carload of cars now on the tracks at Albany consigned to you." In a letter, assistant New York Branch manager A. C. Vanderpoel on August 2, agreed to the unloading of the autos "and [to] apply the rebate earned by you to date amounting to \$560 against the payment for same." Weeber's obligation was reduced to \$1,862.50 but that was not the end of the matter. On August 8, Vanderpoel wrote again:

We to-day wired you as follows:

Have instructed bank to reduce draft on carload nine hundred dollars. Letter follows.

The deduction from this draft represents the approximate amount of the rebate that will have been earned by you, if you take up the carload of cars in question.

We must insist that these cars be taken up at once, as we are compelled to make immediate disposition of them, which would involve trouble to both you and ourselves in the way of readjusting the territory now under your charge.

⁷⁹⁷"AAV" to C. F. Weeber Mfg. Works, July 26, 1910.

As per as late as August 1910 phone conversation with the writer to-day we well expect you to have this draft taken up not later than Thursday. With this in view we are enclosing you herewith a memo for your signature, which we trust you will execute at once and return to us.

Weeber noted on the Vanderpoel letter, "Wrote 8/12 unloaded [8/12]." On August 15, Plaintiff sent a letter to the "Weeber Mfg. Co. encouraging additional sales of the 1910 models of which there were "several thousand. . . to build and sell." The Weeber firm was asked to get after its sub-dealers "at once and keep after them. . . We are looking to your territory for several carload orders this month and ask that you promptly advise what we may expect." Weeber recorded "ans. 8/18." What message he conveyed is not indicated but as late as October 5, 1910, the New York Branch apparently did not know that the Weeber Manufacturing Works was to cease selling Ford cars. On that date, Albert Hirsch sent what appears to be a circular letter to the Weeber firm. After observing that no new contracts had been signed yet with anyone for the coming year, Hirsch stated that the Ford people, in planning for 1911, had "kept you in mind and count upon you as part of our organization, and we certainly hope that after you are made familiar with what our intentions are, you will appreciate the necessity for our delay."

We want you to understand that we want you to continue in the same old way and that the future has many good things in sort for us, and as you all know the Ford methods of doing business, it is needless to go further into detail.

We also want you to feel that we are with you in all your endeavors to place Ford cars. We want you to sell all the cars you can at the present and as our new contracts will have another volume of business clause in them you will be credited with all the sales made between now and the time of the closing of our new contracts.⁷⁹⁸

On October 4, 1910, the Ford Motor Company distributed a price list for the 1911 models to its dealers. Reductions were significant for touring cars and roadsters. Effective November 1, 1910. The former was to sell for \$780 equipped, down

⁷⁹⁸Hirsch to Weeber Mfg. Co. The inside address is in a different ink color from the rest of the typed message.

from \$950, while the latter was \$680, down from \$900. Dealers were encouraged to dispose of present stock, including demonstrators, immediately. Orders taken on or after October 10 would be processed at the new prices, although those would not be public until November 1. Christian Weeber preserved a fine catalogue for the 1911 Ford cars.⁷⁹⁹ Whether the Weeber firm sold any 1911 Fords is unknown here.

In the fall of 1910, Christian Weeber had an account with Scott D. Nichols, the Ford (as well as Premier, Overland and Reo) dealer in Troy. By January 6, 1911, the balance was \$88.76 when Weeber purchased a Model T roadster body. Subsequently, during January, Weeber bought a variety of engine parts for Ford S and T cars. He was allotted a 25% discount but charged for his "share of express." On January 25, Weeber paid \$114.37 by check since the Nichols invoice notes, "Body to pay in spring as agreed." Weeber subsequently penciled, "Pd. 5/19/11."⁸⁰⁰ In brief, by the fall of 1910 Weeber was purchasing Ford parts from a source other than the Ford Motor Company.

The most used second-hand car of the 1910s was the Model T Ford. While the Weeber Manufacturing Works served as agent for a number of non-Ford auto makers, it was inevitable that the company would encounter Fords traded for other cars or Fords brought for repair. Among the reference works received from the Weeber estate in the early 1930s were several Model T publications: a *Ford Manual*, which is undated but apparently, judging by a photograph, for the 1915 models; a *Price List of Parts... Effective May 1, 1915*; and two copies of a *Price List of Parts & Accessories... October 15th, 1917*.⁸⁰¹

Ironically, in the fall of 1910, the Central Automobile Company, once Christian Weeber's business in partnership with Willard Sutherland, Sr., became a successor Ford agency only a few blocks from the Weeber facility. While a display advertisement for "Ford cars at Reduced Prices" might suggest, without additional information that Suther-

⁷⁹⁹H-2000.39.88. Interestingly prices for the slow selling coupe and town car remained unchanged at \$1,050 and \$1,200, respectively.

⁸⁰⁰The bill is dated January 21, 1911.

⁸⁰¹The New York State Museum accession numbers for these booklets are H-1933.6.239, H-1933.6.251, H-1933.6.241 and H-1933.6.242. Grease stains on some of these items attest to their use.

land had acquired a group of cars from another dealer, even Weeber, one should keep in mind, as noted above, that the prices for 1911 model Fords were reduced from those of comparable 1910 models. More significantly, the last line of the Central Company text indicates that the firm had replaced the Weeber Manufacturing Works as the Albany-based distributing agency – "Distributors–Live Dealers want in unoccupied territory."⁸⁰²

⁸⁰²*The Argus*, December 4, 1910.

CHAPTER 9. AGENT FOR THE HAYNES AUTOMOBILE COMPANY OF KOKOMO, INDIANA

1910 Model Year

Christian Weeber represented the Haynes Automobile Company of Kokomo, Indiana, longer than that of any other car manufacturer. From one of the pioneering (1890s) manufacturers and sellers of cars, the Haynes offered mid- to high-price offerings that first complemented Weeber's low price Fords and then later the EMF, Studebaker and Allen cars he sold. In 1909, when the Ford Model T touring car cost \$850, the Haynes cost \$2,900 or \$3,000, depending upon body style. All Haynes at that point used the same four-cylinder, 36-horsepower [sic] engine.⁸⁰³ It was at this time Weeber established his Haynes agency.

Although Weeber was not a Haynes dealer for the 1907 and 1908 model years, Haynes catalogues for those cars survive in the Weeber collection at the New York State Museum.⁸⁰⁴ Whether the Weeber Manufacturing Works relationship with the Haynes Automobile Company began early enough in 1909 to provide Weeber with cars from that model year is uncertain. The author would suggest it unlikely, given the evidence of an undated newspaper clip previously cited apparently from the second half of 1909 in which the Weeber firm is identified as agent for Ford and Ohio cars and Chase trucks.

Rather than with the factory in Indiana, Christian Weeber, in his Haynes business, dealt primarily with the Haynes Automobile Company in New York City. This was a selling and distributing firm, organized in 1908 and incorporated in 1909, that remained legally independent of the Haynes op-

eration in Indiana. President Ernest W. Headington, of the Haynes Automobile Company in New York, was sole stockholder, when, in 1921, the New York-based Haynes organization changed its name to the Haynes Automobile Company of New York, Inc.⁸⁰⁵

Queries about Haynes autos addressed to the Haynes Company in New York at 1715 Broadway⁸⁰⁶ were forwarded to selling sub-dealers. Thus, in December 1909, Headington wrote the C. F. Weeber Manufacturing Works to report that M. E. Luck in Keene Valley had written to ask about Haynes cars. Headington noted that, "While Mr. Luck is not in your territory, he is nearer to you than any of our other agents." Headington already had written to Luck, inviting him to visit the Weeber facility in Albany. Weeber noted on the Headington letter that two days later he had written an acknowledgement to Headington and a letter to Luck.⁸⁰⁷

Also in December 1909, Headington wrote to Weeber to note that Walter L. Gee, of the W. L. Gee Automobile Company in Saratoga Springs, had contacted the Haynes Company "about an agency proposition in his territory." Headington noted that the Saratoga area belonged to Weeber and that he had referred Gee to Weeber, in case the latter

⁸⁰³Kimes, p. 689. Other sites designate it as a 30 horsepower engine.

⁸⁰⁴H-2000.39.93 and H-2000.39.94 respectively. There is also a *Price List of Parts 1906 Models 1907* (H-1933.6.238) with smudges and stains suggesting some use by mechanics. A Haynes reprinting of the National Association of Automobile Manufacturers "Standard Warranty" adopted July 1, 1907, indicates a printing of the 32-page booklet no earlier than that date.

⁸⁰⁵See Haynes Automobile Company certificates of incorporation, increase of capital stock, change of name, etc., in the corporations unit of the New York Secretary of State. Previous to the incorporation of the Haynes Automobile Company of New York, the Haynes operation in New York City was overseen by C. B. Warren. In late 1907, he was appointed general sales manager of the Haynes Automobile Company in Kokomo. It was then that Ernest Heddington [sic] became manager of the New York Branch of the Haynes operation. See *The Horseless Age*, vol. 20, no. 18, October 30, 1907 and no. 20, November 13, 1907. The predecessor Haynes-Apperson Company opened a branch office at 1713 Broadway in 1904; F. Y. Carrie was manager. See *The Horseless Age*, vol. 14, no. 10, September 7, 1904.

⁸⁰⁶Upper Broadway in this period was "automobile row" in Manhattan, the site of many sales emporia.

⁸⁰⁷Headington to C. F. Weeber Manufacturing Works [hereafter abbreviated to "Weeber"], December 7, 1909.

might wish to have a “representative in this territory.” Headington asked Weeber to write to Gee, which Weeber did a few days later.⁸⁰⁸ During this period, *The Argus* noted in January 1910 that, “Mr. C. F. Weeber since taking the agency for the Haynes has made many sales in this section—evidence of the growing popularity of this car among automobilists.”⁸⁰⁹

For 1910, the Haynes Model 19, in a variety of body styles, cost \$2,000. The car utilized the similar four-cylinder, 30-horsepower rated engine as more expensive, discontinued models from the previous year. By November 1909, Weeber display advertisements illustrated and touted the new Haynes (and Model T Ford). The Haynes had “all the earmarks of highest grade, and is as good as it looks, and yet sells for \$2,000 fully equipped.”⁸¹⁰ In February 1910, a small Weeber advertisement in the *Albany Evening Journal* claimed the Model 19 was the “best large car proposition. We invite inspection.”⁸¹¹

In March 1910, the first annual Albany new car show took place at the Washington Avenue Armory. The Weeber exhibit of Haynes and Ford cars reportedly included five-passenger Haynes touring cars, one each with thirty- and forty-horsepower engines [sic]. In addition, there was a thirty-horsepower chassis, likely on loan from the Haynes Company, that allowed “a prospective buyer to see the frame work of the machine.”⁸¹²

A receipt for the Weeber booth at the show survives in the Weeber collection at the New York State Museum. Floor space 2D cost \$125. William J. KcKown, in a letter dated February 22, 1910, asked Weeber how many cars he intended to exhibit so that the committee could make up small signs for them. A penciled list in Weeber’s hand attached to letter notes four Thor motorcycles, three Yale motorcycles, two Minneapolis two-speed motor-

cycles, five Fords and two Haynes as well as the notation that he replied by “phone 2/28.” McKown’s letter also noted the enclosure of 100 Exhibitors Complimentary Tickets to be handed out at will but for which Weeber would be charged \$.25 for any collected at the door of the Armory. The motorcycles, of course, belonged to Emil Weeber, whose cycle shop was adjacent to the Weeber Manufacturing Works on Central Avenue.

Headington traveled to Albany for the auto show, subsequently contacting Christian Weeber to note that Mr. John Knickerbocker, whose address was unknown, had stopped at the Haynes display. Mrs. Charles Henry Johnson of Albany had “called at the booth during the Show and is very much interested in our model 19. Will you kindly take the matter up with her at your earliest convenience?” A day later, Headington asked Weeber to send on orders for cars sold with desired delivery dates so that those orders could be forwarded to the factory “that they may be taken care of at an early date.” Weeber noted that he wrote to New York in reply to the request two days later.⁸¹³

In April, Headington advised Weeber by letter that he had three model 19 touring cars available. These all had Pantasote tops and were finished in Brewster green with cream runner gear, all carmine and all blue respectively. Weeber was advised, “In case you have any calls for immediate delivery, wire us.”⁸¹⁴

On April 13, Charles McDonough put down a \$200 deposit on a “fully equipped” Model 19 at the Weeber Manufacturing Works. The next day he paid an additional \$550 on the total cost of \$2,000. The remaining sum, \$1,250, was written off by Christian Weeber for “Cr ty [carpentry?] work done at building.”⁸¹⁵ This was likely Weeber’s new residence on Manning Boulevard. A letter to Weeber from John H. Jackson, who operated a roofing and masonry materials business, noted in December 1909, “I understand that Mr. Mc Donough

⁸⁰⁸Headington to Weeber, December 18, 1909.

⁸⁰⁹January 30, 1910.

⁸¹⁰*The Argus*, November 21, 1909.

⁸¹¹February 17, 1910. In a column of similar small advertisements, there is none for a Ford agent. The Maxwell was advertised by the Maxwell-Briscoe Albany Company at 72 -74 Central Avenue.

⁸¹²*Albany Press-Knickebocker & Albany Morning Express*, February 11, 1910. The horsepower designation likely is in error. There was only one Haynes model for 1910, the Model 19. The *Haynes Year-Book*, a descriptive catalogue for the 1910 Haynes, gives a horsepower rating of thirty. H-2000.39.95. There was a forty-horsepower engine for 1911.

⁸¹³Headington to Weeber, January 18, 1910 and January 19, 1910. According to 1910 census records, May B. W. Johnson (Mrs. Charles Henry Johnson) was a teacher and the wife of the superintendent of the Albany Orphan Asylum. There is no John Knickerbocker listing in the 1910 Albany directory.

⁸¹⁴Headington to Weeber, April 22, 1910.

⁸¹⁵The Albany city directory for 1910 lists Charles J. McDonough of 477 Hudson Avenue as a general contractor and builder. His display advertisement claimed he did “Work of All Kinds.”



Figure 9.1: The C.F. Weeber Mfg. Works displayed cars in the first Albany Automobile Dealers' Association auto show at the Washington Avenue Armory in March 1910. While Fords are seen in the center of the photo, and Thor motorcycles sold by Christian Weeber's brother, Emil through his Weeber Cycle Works, are on the right. Haynes cars appear on the left side of the picture. NYSM Collection, H-1970.110.50

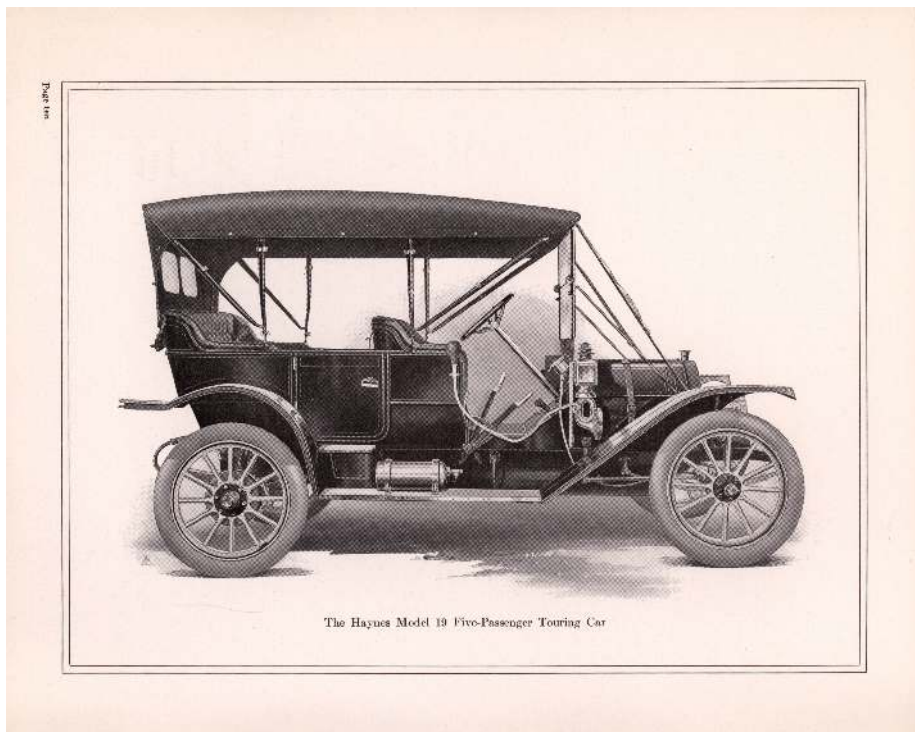

Figure 9.2: *Haynes Year Book* sales catalogue, 1910. Colors were royal blue or Brewster green, both “18 coats, rubbed and varnished. Wheels cream color or same as body.” NYSM Collection, H-2000.39.95.

is putting up your Concrete Foundation, but you have not yet let the Contract for the Plastering.”⁸¹⁶

Also in April 1910, Christian Weeber received a copy of a letter from Julian C. Chase, editor of *Motor* magazine in New York, to Charles H. Bussikummer of the Albany Trust Company. Bussikummer had written to the *Motor* to ask about fuel consumption by the Haynes Model 19. Chase said that the company promised twelve miles to the gallon but “We understand that much better results are actually secured. We consider the Haynes car one of the best upon the market, and certainly a good investment in the motor car line.”⁸¹⁷

Bussikummer apparently had purchased his Haynes from Christian Weeber, with whom he was on a first name basis. An undated letter from Bussikummer to Weeber addresses the latter as “Dear Chris.” Writing from the Bristol Hotel in Asbury Park, New Jersey, apparently while on a summer vacation, Bussikummer noted that the “car has been running fine ever since I came here only one mishap.” After the belt driven by the flywheel broke, Bussikummer had one fabricated “but they dont [sic] succeed in putting one on so that it will not slip off which it does very often every day.” He requested that Weeber send two belts by mail or express as soon as he received the letter “and tell just what to do to put it on properly thanking you for this and past favors I am.” Weeber marked the letter in pencil, “sent 8/31 write 8/31.”

In the Weeber collection at the New York State Museum, a second brochure for the Model 19 claimed the 1910 car was “The Government Bond of Automobile Investment.”⁸¹⁸ A *Haynes Parts List and Instructions 1910* booklet in the Weeber collection at the museum, heavily soiled and marked with price change for some parts, likely was used by the Weeber Works for the maintenance of customer cars. A four-page “List of Parts Showing Changes in Price. Model 19 Model 23, 24, 25 Model 26, 27, 28 Model 30, 33, 34, 35, 36, 37” is marked,

⁸¹⁶Jackson to Weeber, December 4, 1909. Only the first page of this letter survives in the Weeber archive at the New York State Museum. Jackson’s letterhead is printed “Established 1852 New York State Drain Tile and Fire Proofing Works. . . Successor to Jackson Bros.”

⁸¹⁷Chase to Bussikummer, April 16, 1910. *The Argus* for July 5, 1908, reported that Bussikummer, “the new treasurer of the Albany Trust company, has a jaunty new red automobile which Mrs. Bussikummer drives as skillfully as her husband.

⁸¹⁸H-2000.39.96.

probably in Christian Weeber’s hand, in pencil, “File in price list.”⁸¹⁹

In April, a Weeber newspaper advertisement for Haynes and Ford cars said Haynes agents were “wanted in Columbia, Greene, Schoharie, Rensselaer, Schenectady, Saratoga, Washington and northern counties.”⁸²⁰ The implication is that Weeber controlled a vast distribution territory, perhaps as far as the Canadian border. How many agents he procured for this area is unknown here. That he may have had an even larger territory extending westward may be indicated by a 1910 letter from the C. Arthur Benjamin Auto Agency in Syracuse, thanking Weeber for ceding two counties.

Headington’s New York distributorship was not the only source of Haynes automobiles for resale by Weeber. In May 1910, Weeber received a letter from the Reimers Motor Car Company of Louisville, Kentucky, offering a Model 19 limousine at cost, \$2,375. The car reportedly was built for the Reimers Company especially for the local automobile show. While it “created a big sensation,” it did not sell, “owing to the fact that the weather is so warm the Limousines are not used at all.” The vehicle was finished with electric lights, goat skin upholstery and windows finished with mahogany inside and ebony outside.⁸²¹ Weeber noted the letter was to go to the “Haynes file.”

By 1910, the matter of used cars was becoming significant in the automobile business. In January, Weeber corresponded with H. L. Reed, a real estate agent with offices in New York, Albany, Amsterdam and Schenectady, who wished to sell a Model U (1908) Haynes Touring Car. Reed was having the car painted so that it would “come out [from the paint shop] like a new car.” Reed offered to let Weeber keep ten percent of \$1,850, if he could “find me a buyer.”⁸²²

W. B. Guy wrote to Weeber from Cooperstown on October 23, 1910, apparently regarding the purchase or trade and purchase of a used car of un-

⁸¹⁹Haynes Automobile Company, *Instruction Book and Parts Catalog Haynes Automobiles 1910* (Kokomo, Indiana, 1910). The cover below “1910” is stamped “1911,” suggesting a late 1910 printing. Models 36 and 37 were built for the 1917 model year. H-1933.6 305.

⁸²⁰*The Argus*, April 10, 1910.

⁸²¹Carl G. Riemers, secretary (and treasurer), to C. F. Weeber, May 24, 1910.

⁸²²Reed to Weeber, January 25, 1910. Reed said the car, which cost him \$4,000, would be “in apple pie order in about two weeks.”

specified make. "Your telegram was phoned to me this P.M from Utica as I understand it you want 300 dollars to boot if I do not care to trade I have a better offer on a new car."⁸²³

Another potential trade of an older car for a new one was the subject of correspondence as Headington sent Weeber a letter received from John K. Alexander of Schenectady, who wished to trade a "special Haynes car." Alexander had purchased the car from Headington about a year earlier for \$1,000. Headington estimated its current worth at \$500 or \$600.

Headington told Weeber that the matter of a trade was up to Weeber, "and I shall leave this entirely to your own discretion whether you trade with him or not. I realize that the second hand business is the unfortunate part of the automobile business and as you know about what amount of trading you care to do, I shall leave this matter to you."⁸²⁴ Weeber's penciled note on the Headington letter is indistinct but may read, "Haynes 1/31 offer."

Perhaps even new Haynes cars were potentially troublesome. In October 1910, Schenectady pharmacist Henry A. Kerste wrote to Weeber:

Enclosed please find my check for \$3097 for payment in full. I am still having trouble with Car. What will you allow me for it. I will take back my old Car. I will take any offer within reason. You will be more able to take matter up with the Haynes Co. then I will be & get an adjustment. Kindly let me know.⁸²⁵

Pencil notes on Kerste's letter include, "chk. ok a." and "10/10 will let know shortly."

The sale of both Ford and Haynes automobiles together created a problem for Weeber. In the 1910 period, the matter of the Selden automobile patent legitimacy was coming to a head. George B. Selden's claim that he had patented the basic design of the internal-combustion powered automobile had led to two groups of manufacturers, one which paid a royalty and one which rejected the Selden patent claims. The Haynes Company was among the licensed manufacturers, while the Ford Motor Company led the group rejecting the patent.

⁸²³The letterhead is printed "Hoffman House." Guy's letter is dated October 23, 1910. He noted "at home after Oct. 26.27. [26th or 27th]."

⁸²⁴Headington to Weeber, January 31, 1910.

⁸²⁵Kerste to C. F. Weeber, October 6, 1910.

In the winter of 1910, the Ford Motor Company advertised that if requested, it would give each Ford buyer a bond "backed by a Company of over \$6,000,000.00 of assets [plus \$6,000,000 of assets from the bonding company]...so that every individual owner of a Ford car will be protected..." from suit by the association of licensed manufacturers. In fact, at least one Weeber customer, E. G. Rice of Albany, received such a bond. In sending the bond, Ford assistant commercial manager, H. B. Harper, wrote to the Weeber firm. "If you have any other customers in your territory, who would feel a little easier about it if they had a bond, do not feel any hesitation about asking for it. The only information we require is the car [serial] number."⁸²⁶

In April 1910, Headington wrote to Weeber that he regretted "to advise the Licensed Association are after us because of the fact you are handling Ford cars in connection with our car. I have explained to them the act that our contract is with you personally while that of the Ford Company is with the Weeber Mfg. Co., but this does not satisfy them."⁸²⁷

"Have you any suggestion to make whereby we could get around this difficulty.[sic] I am frank to admit our business dealings with you have been absolutely satisfactory and I regret very much this point should come up at the present time..."⁸²⁸ Weeber noted that he, "Called at N.Y. 5/11."

Perhaps ironically, in May Weeber apparently received a broadcast letter from the Association of Licensed Automobile Manufacturers addressed to "Dear Sirs," stating that since the recipient handled licensed cars, "we will be glad to furnish you free of charge, upon request, two handsome and effective signs, as illustrated herewith" as well as "any reasonable number" of copies of a pamphlet entitled "What is the Selden Patent?" The text of the sign, "suitable for either hanging on the wall or in the window or standing on a table," read "Cars Sold Here Are Licensed Under Selden Patent." The text of the letter continued with a list of suits recently filed against non-licensed manufacturers.⁸²⁹

⁸²⁶The Ford advertisement was reproduced in the *Ford Times*, vol. 3, no. 10, February 15, 1910, pp. 10-11, with the note that it had appeared "in Recent Issues of New York and Chicago Papers." Harper's letter dated March 12, 1910, was sent to C. F. Weeber & Co.

⁸²⁷Headington to Weeber, April 27, 1910.

⁸²⁸Ibid.

⁸²⁹Alfred Reeves, general manager, May 14, 1910.

This Bond Assures Real Protection

to Owners of Ford Cars

No. **3**

Ford Motor Company



National Surety Company

Know All Men By These Presents:

THAT WE, FORD MOTOR COMPANY, a corporation organized and existing under the laws of the State of Michigan, and having its principal place of business in the City of Detroit, in the said State, as principal, and NATIONAL SURETY COMPANY, a corporation organized under the laws of the State of New York, and having its principal place of business in the City of New York, as surety (both of which corporations will, for the sake of brevity, be hereinafter referred to as the "OBLIGORS") do hereby covenant and agree with the purchaser or purchasers of Model T Car No. 9-28, its mechanism and every part thereof, manufactured by said FORD MOTOR COMPANY, that they will indemnify said purchaser or purchasers, his, its or their executors, personal representatives, assigns and successors, and save them harmless from all claims, demands and actions, either in law or equity, which may be brought against them or either of them by any licensee, assignee, trustee, owner or holder of Letters Patent of the United States No. 549,160, commonly known as the "Selden Patent" for any alleged infringement thereof and for any royalties, profits or damages arising therefrom.

IT IS A CONDITION PRECEDENT in any recovery herein that notice in writing shall be given by said purchaser or purchasers, his, its or their executors, personal representatives, assigns and successors, to each of said "OBLIGORS" not later than ten (10) days after any claim, demand action or suit for such alleged infringement has been made or brought against them to enforce the same, whereupon said "OBLIGORS" or either of them shall have the right, at their own proper cost and expense to defend such claim, demand, action or suit.

IN WITNESS WHEREOF, the said FORD MOTOR COMPANY and the said NATIONAL SURETY COMPANY have caused these presents to be executed by their duly authorized officers or attorneys in fact, this _____ day of _____, 1911

FORD MOTOR COMPANY,
By J. B. Stanger
Attorney in fact

NATIONAL SURETY COMPANY,
By J. C. Leonard
Attorney in fact

Figure 9.3: Reproduction of Ford Motor Company–National Surety Company bond. *Ford Times*, vol. 3, no. 12, March 15, 1910, pp. 15-16. The bond issued to purchasers of Ford cars as protection against Selden Patent claims. "It represents \$12,000,000.00 worth of protection and it is yours for the asking." NYSM Collection, H-2000.39.166.

The Selden matter had not yet been settled, either globally or in the specific Weeber case, as Haynes sales manager, C. B. Warren in Kokomo, wrote to the "Weeber Auto Works" on October 1, 1910. Warren said the "Association of Licensed automobiles" had reported that Weeber was selling the Ford car. "In order that the Association may be satisfied that you are not handling the Ford, we ask that you sign and return to us the enclosed affidavit, sworn to in due form." Weeber noted, "10/10 wrote will let know within next few weeks." On October 12, Warren acknowledged Weeber's letter of the tenth and that Weeber was "getting matter in such shape that the License Association can have no criticism at your point."

In this connection, we must beg to advise that we must have the affidavit signed and returned at once. When matters of this kind gets [sic] into the hands of the Association, it is beyond our control. If they should notify us that we should cancel your contract, we have not [sic] alternative in the matter. We, therefore, beg of you to get it to us promptly, signed, that we may satisfy the association.⁸³⁰

Although a January 9, 1911, federal court ruling nullified the Selden patent,⁸³¹ Weeber's relief in the licensing dilemma had come through his dropping the often contentious association with the Ford Motor Company in favor of cars manufactured by the Studebaker Corporation, a licensed producer. Meanwhile he continued to sell and repair Haynes cars.

The number of Haynes sales in 1910 by the C. F. Weeber Manufacturing Works seems to have been small but without a surviving record of the vehicles sold outright to end users or moved to sub-agents, any figure is speculation. Total Haynes production for 1910 was "about 1,000 automobiles", a modest figure compared to approximately 19,000 Fords.⁸³²

In May 1910, a potential Weeber customer apparently asked about the availability of a Haynes with a toy tonneau body. Headington, as manager of the Haynes Automobile Company of New York and

Weeber's supplier, wrote that he had telegraphed the factory and thought he "shall be able to fix you up." A following letter acknowledges that the "customer cannot wait for the toy tonneau. In case you are in need of anything for immediate deliver at any time, let me hear from you and if possible I will take care of you."⁸³³

In June, Headington wrote to ask about "prospects for business in the immediate future" for 1910 models. He had "one or two cars oe [sic] every type" for delivery "and we would appreciate any special effort that you might make to move any of these cars." The next day a letter, following a telegram, listed a blue and yellow touring car, a green and yellow touring car and a brown touring car, any of which could be equipped either with a mohair or Pantasote top.⁸³⁴

In July and August, A. G. Williams and Headington respectively, wrote to ask if Weeber could "move one or two 1910 cars before the season closes" or "what might be the prospect for moving one or two 1910 cars at the present time."⁸³⁵

In 1910, Weeber had constructed a coupe body on a Model 19 Haynes chassis for a Dr. Shaw. What agency actually fabricated the body and what changes were made are unclear. Possibly John Kingsbury was the builder (see Chapter Seven). The author assumes Dr. Shaw is the same individual who owned the Ford the Weeber Works repaired the year before. While this might have been Henry L. K. Shaw, a physician whose office and residence were at 361 State Street in Albany,⁸³⁶ it likelier was William F. Shaw of Voorheesville. On December 21, 1907, W. F. Shaw, from the Piney Woods Inn in Southern Pines, North Carolina, wrote to the C. F. Weeber Manufacturing Works that a bill forwarded to him from Voorheesville remained unpaid because he had "neglected it.—If you will call my attention to this account when I

⁸³³Headington to Weeber, May 23 and May 28, 1910. Apparently there was another customer for a toy tonneau, for Headington on June 18, 1910, in a postscript to a letter noted, "Toy tonneau dust covers will go forward Monday."

⁸³⁴Headington to Weeber, June 13 and 14, 1910.

⁸³⁵Williams to Weeber, July 21, 1910 and Headington to Weeber, August 19, 1910. Williams said he had a blue toy tonneau, a blue with cream running gear touring car and a blue and cream roadster. Headington offered a blue and yellow touring car as well as a blue and yellow toy tonneau.

⁸³⁶Henry L. K. Shaw is listed at the State Street address in the 1910 and 1911 city directories. The 1910 census shows he was 36 years old and in general practice.

⁸³⁰Warren to C. F. Weeber Mfg. Company, October 12, 1910.

⁸³¹Robert Lacey, *Ford the Men and the Machine* (Boston, 1986), p. 101.

⁸³²W.C. Madden. *Haynes-Apperson and America's First Practical Automobile* (Jefferson, North Carolina: McFarland & Company, Inc., 2003); Kimes, *op. cit.*, says there were 1,083 Haynes and 19,050 Fords for model year 1910.

return home about Jan. 1st will send check—Have no check book with me or would write at once.”⁸³⁷

As Gaston Plantiff noted, quoted above a letter to Christian Weeber, physicians in the late 1890s and 1900s were strongly represented among pioneers in adopting automobiles for professional travel. Since calls from the sick came year-round, Shaw (whichever Dr. Shaw this was) and Weeber probably saw the coupe body as an asset in responding to winter emergencies.

Acknowledging a photo of the Shaw coupe Weeber sent to the Kokomo office, Haynes General Manager Harry H. Elmer said the car had “some class to its appearance. I shall take great pleasure in showing this to some of our agents who come to the factory quite frequently.”⁸³⁸ Acknowledging a photo sent to the New York agency, Headington wrote that if Weeber had “larger photographs, something suitable for framing, we should be very glad to have them.”⁸³⁹

Christian Weeber’s relationship with Elmer apparently was a personal one. In August 1910, Weeber wrote to “Mr. Elmer c/o Haynes Auto Co.,” addressing his correspondent, “Dear Friend.” The message basically was a request for assistance in the repair of Shaw’s car.

Some time ago we ordered cap for gasoline tank for Dr Shaw’s Car, the one I sent you photo of. He is very much displeased the way parts are shipped & is starting to talk about it. We had his car in for repair yesterday & I find the front drive shaft universal joint very much worn & he feels very uneasy about it. Don’t you think it best to send us a joint by return express together with gasoline tank cap so I can again get him in a pleased mood. Hoping to receive same by return express & thanking you for same I am Yours Respt.⁸⁴⁰

⁸³⁷The 1910 federal census shows William F. Shaw and his wife, Ella Wood Shaw, as residents of Maple Avenue in Voorheesville. He was a 46-year old physician in general practice. The Shaws, as well as her father living with them, also appear in the 1930 census.

⁸³⁸Elmer to Weeber, August 1, 1910.

⁸³⁹Headington to Weeber, September 27, 1910.

⁸⁴⁰C. F. Weeber to Elmer, August 4, 1910. Weeber has marked his letter, the copy of which is on his company letterhead, “Duplicate sent 8/4.”

1911 Model Year

In August 1910, the C. F. Weeber Manufacturing Works advertised that it had used cars for sale, “All Prices, Ranging from \$50 Up,” that needed to be sold “to make room for our 1911 models. Our prices will be very attractive. All cars will be guaranteed to be in good condition.”⁸⁴¹

For 1911, the Haynes line was split into two models: the \$3,000 Model Y on a 125-inch wheelbase with a 40-horsepower engine; and the \$2,100 Model 20 on a 114-inch wheelbase powered by a 28-horsepower engine. Headington at the New York agency wrote to Weeber on August 29, 1910, in response to a Weeber query about the introduction of the 1911 models. Deliveries of the Model 20 were to begin as early as the end of the week (the letter being written on a Monday). Williams was to call on Weeber as soon as the next day, hoping to get an order for a demonstrator vehicle. The Model Y, on the other hand, “will not come through for at least sixty days” but Headington wanted to know what Weeber thought “about the prospects of moving a few of these large cars in the vicinity of Albany. It is a ‘cracker-jack’ proposition, and at the price will compare with any of our competitors.” Headington concluded his letter by acknowledging Weeber’s apparent offer to “move one of the [remaining 1910] Model 19s in your territory.”⁸⁴²

A surviving “selling agreement” dated September 3, 1911, between the C. F. Weeber Manufacturing Works and the Haynes Automobile Company of New York, is signed by Headington for Haynes and “C. F. Weeber” as a dealer. The selling agreement provided the Weeber Company with Albany, Schenectady, Schoharie and Greene Counties as its sales territory “and to have the right to sell in any unoccupied territory until each time he may be notified by letter or other written notice from the company to the contrary” until August 30, 1911.⁸⁴³

Weeber agreed to purchase thirteen Model 20 and two Model Y. These vehicles were to be

⁸⁴¹*The Argus*, August 21, 1910. The display ad continued, “Don’t fail to call, as it will mean a big bargain for you.” The company name, likely through an oversight in proofreading, is given as “C. F. Weeber Mfg. Co.”

⁸⁴²Headington to Weeber, August 29, 1910.

⁸⁴³Unoccupied territory did not include Troy, where the city directory for 1911 carried an advertisement for the Bolton-Myers Auto & Truck Company, dealers in Haynes and Parry vehicles, at 191 River Street.



Figure 9.4: Photographs of Haynes Model 19 coupe. This is the coupe-bodied Haynes that Christian Weeber had constructed for Dr. Shaw. The images are snapshots, perhaps similar to the photos sent to Elmer and Headington prompting the latter to ask for larger prints “suitable for framing.” NYSM Collection, H-2000.39.106,108.

shipped in September (one), December (one), January (two), February (two), March (three), April (four) and May (two). The contract provided for a 20% discount to Weeber on the cost of the cars and on parts. In return, he agreed not to offer the cars at less than the “catalog list price.” He agreed to pay for the cars when notified that they were ready for shipment or to have sight drafts attached to the “Bill[s] of Lading F.O.B. Kokomo.” Weeber further agreed to sell only within the territory allotted to him; to forward inquiries from outside his territory to the Haynes Company in New York; to have “at all times at least one workman who shall thoroughly understand the different types and styles of **Haynes Automobiles**; to thoroughly and diligently advertise and push the sale of the **Haynes Automobile**” within his territory; and to have one car on display and one for “demonstrating purposes.” In the event that Weeber appointed a sub-dealer, he was to sign a contract, “which is practically a duplicate of this agreement, and is subject to the approval of the [Haynes] Company...”

Since the Selden Patent was still in effect at the date of the signing, and the Haynes manufacturer was “paying substantial royalty thereunder,” Wee-

ber agreed not to “make, sell directly or indirectly any unlicensed vehicles, that is to say, any gasoline automobiles not manufactured under license under the Selden patent” during the contract period.⁸⁴⁴

On September 27, 1910, Weeber telegraphed the New York agency twice to order a 1911 Model 20. The next day, Headington acknowledged receipt of the specifications for the car, which was “guaranteed for delivery the last week in October. A telegram from Headington to Weeber on October 22, confirmed, “Will deliver car on date promised.” A bill to Weeber in February 1911 for a Model 20 with serial number 61 and engine number 3513, shows a cost of \$1,600 plus \$30 for freight.⁸⁴⁵ This indicates a then standard 20% discount from the list price to the Haynes retail seller.

For the Albany Auto Show in the Washington Avenue Armory in February 1911, the Weeber Manufacturing Works indicated it would display (in addition to E-M-F and Flanders autos) five

⁸⁴⁴Weeber collection at the New York State Museum.

⁸⁴⁵Headington to Weeber, September 27 and 28, 1910. Telegram: Headington to Weeber, October 22, 1910. The bill dated February 15, 1911 and marked paid on February 18, 1911, likely is for a car other than that delivered in October.

Haynes cars: four Model 20 vehicles with various body configurations costing \$2,000 or \$2100, as well as a seven-passenger, “fully equipped” four-door, Model Y touring car at \$3,000. A display advertisement suggested visitors to the show that they:

Just keep your eyes peeled for our booth if you wish to purchase the best your money can buy. We will not take up your time here [in this advertisement] to show cuts, etc., but will leave this to show you when you call, where we can explain more fully and have the goods before us, so we can explain merits, etc. All you want is the goods that will perform perfectly, and give you the desired looks and pleasure. Then, after you buy, results is [sic] what you want. If this is what you are looking for we have the cars that will do it...⁸⁴⁶

The Weeber accession by the New York State Museum following Weeber’s death included a thirty-six page *Haynes Price List of Parts for Models 19 and 20 1910-1911*.

1912 Model Year

For 1912, there were 30, 40 and 60-horsepower Haynes cars for \$1,650 to \$3,900.

A “selling agreement” dated September 1, 1911, between the C. F. Weeber Manufacturing Works and the Haynes Automobile Company of New York, is signed by Headington for the Haynes company but remains unsigned by Weeber. Likely, two copies of the contract were sent to Albany, the second and signed copy having been returned to New York.

The agreement continued Weeber’s selling territory in Albany, Schenectady, Schoharie and Greene counties. In return, the Weeber firm contracted for twenty Model 21 (40-horsepower) and five Model Y (60-horsepower) cars. Weeber was obligated to place a \$300 deposit with the Haynes Company for the duration of the contract. Other terms were identical to those in the agreement signed the year before, except all references to the Selden Patent had been eliminated.⁸⁴⁷

While there was no Albany Automobile Show during the winter of 1911-1912, there was an event

⁸⁴⁶*Albany Evening Journal*, February 22 and February 24, 1911.

⁸⁴⁷Weeber collection at the New York State Museum.

in Troy in mid-February. The Albany Sunday *Knickerbocker Press*, in anticipation of the opening of the show in the armory at State and Ferry Streets, presented a story of pioneer automobile days in Albany. While claiming that the “Gasoline Car of Hains [sic] the First” in the United States, “Weeber of Albany Followed Suit.” Since Troy was outside Weeber sales territory for Haynes cars, the Weeber Manufacturing Works did not exhibit in the show. Rather Bolton and Myers of Troy displayed Haynes (and Parry) cars.⁸⁴⁸

A program for the “Haynes House Party,” held June 25-27, 1912 in Kokomo, survives in the Weeber collection at the New York State Museum and suggests that Christian Weeber attended the event. Designed for Haynes dealers, the program consisted of many talks, some as brief as ten minutes on such topics as “Carburetion,” “Know Your Goods,” “Care of the Elba Storage Battery” and “Reaching the Ultimate Purchaser.” Presenters included Elwood Haynes and East Coast Haynes manager E. W. Headington. Representatives of a variety of journals, such as the *Scientific American*, *Brooklyn Eagle* and *Motor World*, spoke. A factory tour was on the schedule. The final banquet took place at the Y.M.C.A.

Among new Albany owners of Haynes cars in early April 1912 was J. [John] R. Carnell, Jr., Christian Weeber’s boyhood friend. Carnell likely purchased his Haynes from the Weeber Manufacturing Works.⁸⁴⁹ Two other newly licensed Haynes cars in April were owned by teamster William Hesch of 504 First Street and osteopath Dr. Mae V. D. Hart of 140 State Street.⁸⁵⁰ At the end of April or in early May, Peter McCabe of 28 William Street registered a Haynes.⁸⁵¹

⁸⁴⁸Advertisement in the *Knickerbocker Press*, February 11, 1912.

⁸⁴⁹A list of early April registrants, their addresses and the makes of cars appears in the *Knickerbocker Press* for April 14, 1912. Carnell, who lived with his sister and widowed father at 469 State Street, was the only Haynes registrant in an extensive list including car owners in Albany, Rensselaer and Schenectady counties. See a later chapter of this book for comments Carnell made about Weeber at the latter’s death.

⁸⁵⁰*Knickerbocker Press*, April 21, 1912. Again, these were the only Haynes registrations reported in an extensive list of cars licensed the previous week in Albany, Rensselaer, Schenectady and Saratoga counties.

⁸⁵¹*Knickerbocker Press*, May 5, 1912. McCabe also registered a White truck, likely purchased from a dealership other than the C. F. Weeber Manufacturing Works.

In early 1912, the *Knickerbocker Press* estimated that 2,000 cars had been sold in the city of Albany since 1901. At the time of its article, February 11, the paper said about 600 cars were registered in Albany County. While by twenty-first century standards those two figures and the number of cars sold in the 1910 period by the C. F. Weeber Manufacturing Works seem small, Christian Weeber's success, especially in the years he sold Ford cars in addition to Haynes (never a large seller) and other makes, was significant.

1913 Model Year

In 1913, there was a six-cylinder Haynes but the most expensive vehicle in the line remained a four-cylinder, \$3,500 limousine. At the annual Albany Automobile Show, held at the Washington Avenue Armory from February 15 through 22, 1913, the C. F. Weeber Manufacturing Works displayed one each of Haynes Models 22 and 24 touring cars. Also in the three-space Weeber display area were two Studebaker touring cars (Models 25 and 35) and a Model 35 limousine.⁸⁵² Christian Weeber, a member of the show's executive committee, served as chairman of the poster committee. Weeber's advertisement in the show program claimed the Haynes and Studebaker cars "Stand Supreme in Their Line."⁸⁵³

Among Haynes advertising materials for the 1913 Model 22 was a hard-cover, twelve-page booklet entitled, *The Complete Car*.⁸⁵⁴ Emphasis was on the self-starter, a component new for 1913, but mention was made as well of the Haynes clutch, suspension, engine and upholstery. Five copies of the booklet, three in their original brown paper envelopes, were received by the State Museum from Pauline P. Weeber.

A *Haynes Parts List and Instructions for Models 21 and 22 1912-13* is also part of the Weeber legacy preserved at the State Museum. Much smudging and many greasy fingerprints point to extensive reference by Weeber's mechanics. A few price changes

⁸⁵²Albany Automobile Dealers' Association, *Official Program*, p. 73. Emil Weeber's Weeber Cycle Works elsewhere in the show displayed three Thor and three Indian motorcycles.

⁸⁵³*Ibid.*, p. 26.

⁸⁵⁴Haynes Automobile Company (Kokomo, Indiana, n.d.). The last page is marked "Designed and Written by the Dunlap-Ward Advertising Company[,] Chicago."

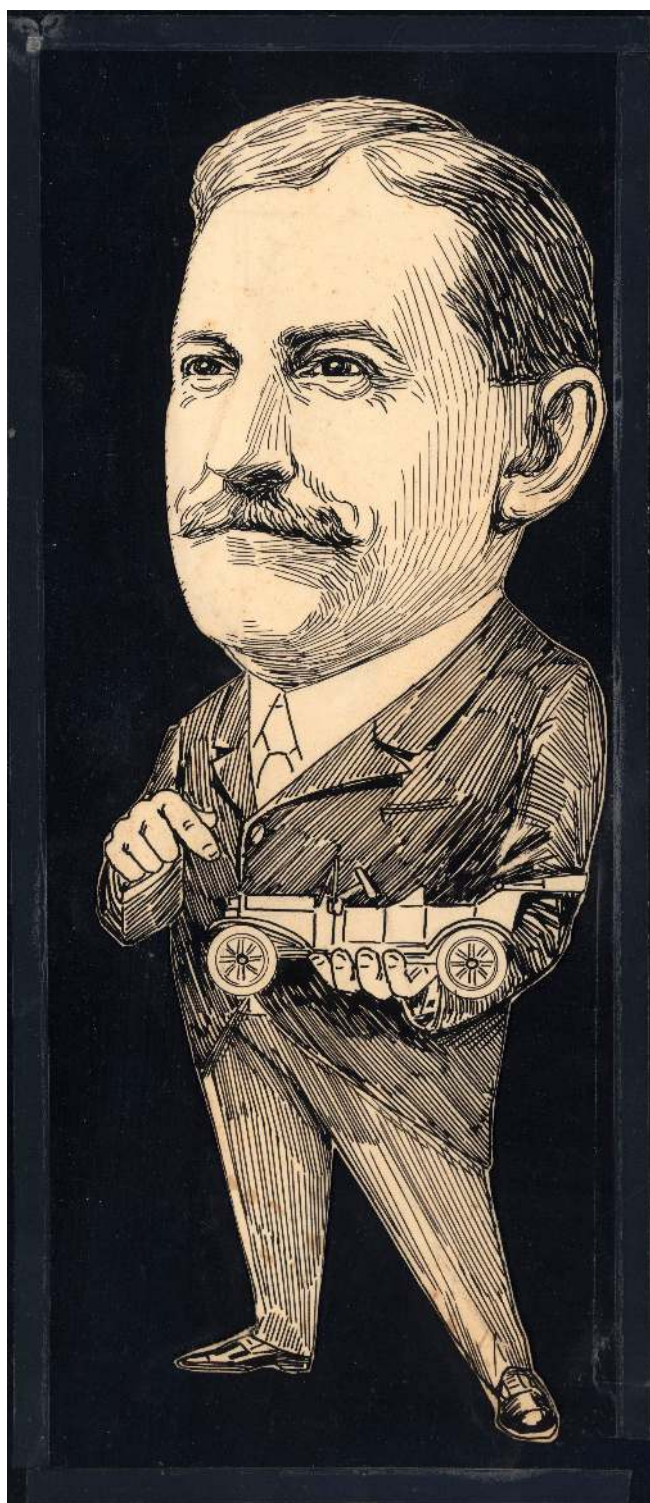

Figure 9.5: *Times Union*, February 18, 1913. Christian Weeber depicted in a caricature by Lorenzo W. Ford during the annual automobile show at the Washington Avenue Armory. Weeber is identified as "Pioneer Auto Man. Inventor—Haynes N Studebaker." In defense to a claim by C.D. Hakes of the Albany Garage, that the Chalmers is the best car on the market, Weeber responds, "That's true but the HAYNES is the Best—and then some!" NYSM Collection, H-1970.110.44.

have been noted by hand. Similar *Haynes Parts List and Instructions for Model 21 1912* and *Instruction Book and Parts Price List Models 23, 24, 25* (1913), on the other hand, apparently saw rather little use.

1914 Model Year

Christian Weeber, again a member of the executive committee⁸⁵⁵ and in charge of posters in 1914 (and 1915), displayed both

Haynes and Studebaker autos at the annual auto show. The Haynes featured an electric gear shift, which the *Albany Times Union* claimed would eliminate the hand lever “for all time, not only insofar as the Haynes car is concerned, but among all the manufacturers of medium priced cars, who will likewise adopt this new mechanism, with the advent of the 1915 season.” The electric gear change was to be standard on all 1914 Haynes models.⁸⁵⁶ The newspaper likely was rewriting from a Haynes press release. In any case, the electric gear change was not a success and subsequently dropped from the Haynes equipment list.

Christian Weeber identified, as “an expert judge of motor vehicles” (and his company “the pioneer among auto dealers in this city”), spoke to a reporter for the *Albany Evening Journal* before the show. While credited to Weeber, the *Journal* wording perhaps suggests Haynes publicity.

I believe there are more women driving Haynes cars today than at any other time in the history of the company. Also that a larger percentage than ever before of the visitors to the automobile show, and particularly to the Haynes exhibit, belong to the gentler sex. The trend in automobile building in the last two seasons has been toward refinement, manufacturers having thoroughly satisfied themselves that in addition to furnishing

⁸⁵⁵*The Argus*, March 9, 1914, indicated that committee members, including Weeber’s former partner W. J. Sutherland, had, according to Chauncey Hakes president of the Automobile Dealers’ Association, “done everything possible to give the public what we promised in the way of an up-to-date and satisfactory show....”

⁸⁵⁶March 7, 1914. A Haynes-supplied display advertisement, with the C. F. Weeber Manufacturing Works name and address included, in *The Argus*, March 8, 1914, features a drawing showing push buttons for the various gears located in the center of the steering wheel. Readers were invited to arrange a Haynes demonstration. “We will not urge you to buy, but will appreciate the opportunity of demonstrating the superiority of the Haynes car to you.”

mechanical improvements to appeal to the men, they must add to the luxury, comfort and convenience of their cars for the benefit of the women folks. For instance, with the adoption of the Vulcan electric gears shift, we have not only appealed to the men as a mechanical proposition, but we have also been favored with the hearty approval of women motorists the country over, because this wonderful device has simplified driving to such an extent that anyone who can steer straight can now easily drive a Haynes car. But we did not stop there. We have catered to the taste of the most discriminating women, especially in building our closed body cars, with the most gratifying results. For luxury in appointments, beauty in design, comfort and convenience, our limousines and coupes are equal to any other cars regardless of price. What is the result? Thus far nearly all our closed body cars are sold, so that with the remaining few bodies left it is now a case of first come, first served. I attribute this condition, in a large measure, to our adoption of the electric gear shift, because our cars are now electrically controlled throughout, and for that reason many men and women who have been denied the pleasures of motoring find in the electrically controlled gasoline car a combination hitherto not obtainable.”⁸⁵⁷

To an *Argus* reporter Weeber said:

Let me tell you...As a slogan, “First in the field - ahead of the times always” sounds good, and how many manufacturers are there that can live up to it? Only one that I know of, and that is the Haynes Company.

It is known the world over that Elwood Haynes, president of the Haynes Automobile company, invented, and built the first gasoline self-propelled vehicle in the years 1892-1894, and the original of which has been for many years on exhibition at our National Museum, the Smithsonian Institution, Washington.

It is also an acknowledged fact that Elwood Haynes has either been the originator or among the first to adopt every important improvement on the automobile, since he built

⁸⁵⁷March 3, 1914. A book credited to Elwood Haynes pen, *The Complete Motorist* (Kokomo, Indiana: privately printed, 1913-1914), describes the operation of the electro-pneumatic gear shifting device. In large part the *Motorist*, two copies of which are among the Weeber artifacts at the New York State Museum, describes the 1914 Haynes cars but it also includes a history of the Haynes Company.

the “horseless carriage” back in ‘93. The long list of “firsts” which he has to his credit is evidence enough of his leadership in automobile construction.

Elwood Haynes was ahead of the times 11 years ago when he turned his dream of building a self-propelled vehicle into a reality – and he is ahead of the times to-day when he adopts the electric gear shifting mechanism, the greatest refinement in automobile construction in recent years. The device entirely eliminates the hand shift lever, and permits the driver to shift gears by electricity, silently, skilfully [sic] and without physical effort.

As I say, a slogan sounds good, but it is necessary to live up to it, and the Haynes Company has certainly merited the one just adopted, “first in the field—ahead of the times always.”⁸⁵⁸

As befitting his status as a pioneer dealer, at the auto show on March 9 Weeber displayed one of the first cars built by the Weeber Manufacturing Works. This one-cylinder touring car that has been part of the New York State Museum collection since 1933. In 1914, “procured [by Weeber] from B. McNary of Rensselaer,” it was “a veteran four-wheeler which has the distinction of being one of the earliest cars in this part of the state still in running order”.⁸⁵⁹ That car is described more comprehensively elsewhere in this work.

A *Haynes Price List of Parts for Models 26, 27, 28* came to the New York State Museum from Pauline Weeber. Soiling and a column of penciled numbers added on the back cover show the 56-page booklet provided some service to the Weeber Manufacturing Works.

1915 Model Year

In February 1915, the *Albany Evening Journal* quoted Christian Weeber extensively about the power and efficiency of the Haynes Light Six. While the words are ascribed to Weeber, one might wish to compare the text of the study made at the Worcester Polytechnic Institute, whose test is described in a Haynes press release. In case these statements are, indeed, literally transcriptions of Christian Weeber’s talk to a *Journal* reporter, the text of the article is reproduced here in its entirety.

⁸⁵⁸March 8, 1914.

⁸⁵⁹*Albany Evening Journal*, March 10, 1914.

According to the results of the test just completed at the Worcester Polytechnic institute, the Haynes Light Six actually delivers 41.25 horsepower at the rear wheels, states C. F. Weeber of the C. F. Weeber Manufacturing Company, distributors in this territory for the Haynes, America’s first car. Such power at the rear wheels is remarkable. A stock car was used and operated under the same conditions as encountered in actual road driving. An unusual characteristic that the test brought out is the fact that there is no drop in the horse power delivered until a car speed of 60 miles per hour is attained. This power that is delivered to the point where actually used in propelling the car is 136 per cent the S.A.E. rating of 29.4 horse power. The motor is 3 1/2x5 inches with the six cylinders cast en bloc.

The fact that such a great amount of power may be obtained at the rear wheels, with a motor of this size, is still more significant when it is considered that the car had been run but 600 miles before the test was made.

Losses between the motor and the rear wheels are approximately three per cent in the universal joints and four to seven per cent in the drive gears. The greatest loss is in the tires. This loss amount [sic] to about 15 per cent, depending upon the make of tire and its inflation.

The efficiency of an automobile is the ratio of the power delivered at the rear wheels to the power actually developed by the motor. Considerable power is always lost in transmitting the power from the engine to the point of usage. If the motor developed 100 horse power and but 50 horse power was available at the rear wheels, the efficiency would be but 50 per cent. Automobile effectiveness is determined by the weight, and the power delivered at the rear wheels.⁸⁶⁰

For 1915, in addition to Studebaker cars at the annual Albany Auto Show in March, the Weeber Manufacturing Works was to display at the State Armory in spaces 42, 43 and 44 a Haynes Light Six and a Haynes Kokomo Six, a “touring car with special equipment peculiar to this make—it is an exclusive car in every particular.”⁸⁶¹ The Weeber Manufacturing Works advertised the Haynes Light

⁸⁶⁰February 18, 1915.

⁸⁶¹The automobile show program for 1915 records the Weeber Manufacturing Works display of Studebaker cars and at least one Studebaker delivery vehicle but does not mention Haynes. The *Albany Times Union*, however, March 13, 1915, mentions the Haynes cars at the Weeber booth.

Haynes' 4 Cylinder
Electric Shift, \$1,985.00

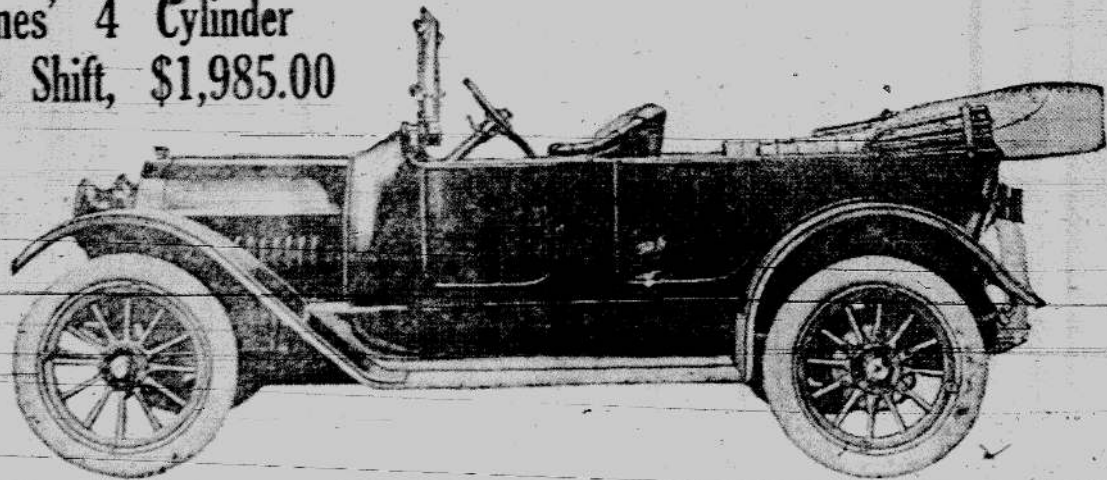

“HAYNES”

The Haynes is the oldest American automobile. But one was built during the 1893-1894 season—the first successful self-propelled vehicle in this country. It now stands on exhibition in the Smithsonian Institution, Washington, D. C. Today, this season, three thousand Haynes cars will be built—and sold. Sold, not alone because the Haynes possesses this, the greatest of all records and exclusive to the Haynes car, but because its owners have been demonstrating during these twenty-one years in road “races,” in reliability “runs,” in “hill climbs,” of every description, under all conditions, in this country and abroad, with themselves the only “competitors,” that Haynes cars are good cars, and that given ordinary care and attention, the Haynes remains a good car, a mighty good car—indefinitely.

Another feature possessed by the present day Haynes, which, though not exclusive, is practically so, and one which has made the Haynes the most widely-discussed car in America, is the Vulcan Electric Gear Shift, conceded everywhere as the acme in automobile refinement.

When the Haynes Automobile Company adopted the idea of shifting gears by electricity, the use of the hand lever was abolished for all times, not only in so far as the Haynes car is concerned, but among all manufacturers of medium priced cars, who will likewise adopt this new mechanism, with the advent of the 1915 season. Meanwhile, the Haynes Automobile Company offers it now as standard equipment on all models.

C. F. WEEBER MFG. WORKS

Automobiles and Supplies

170-172 Central Ave.,

Albany, N. Y.

Figure 9.6: In the *Albany Evening Journal*, March 3, 1914, Weeber Mfg. Works display advertisement touted the Haynes Electric Gear Shift the day before the opening of the Albany Auto Show. Courtesy of the New York State Library, Manuscripts and Special Collections.

Six in Albany newspapers in conjunction the annual show.⁸⁶²

A lapel button in the New York State Museum collections, H-1970.110.4A, is marked "Troy Auto Show Feb. 1915." It is possible Christian Weeber, member of the executive committee for the Albany Auto Show, attended the Troy exposition as a visitor or perhaps an advisor rather than as an exhibitor.

1916 Model Year

Having dropped the Studebaker line for 1916, Weeber, in the same Albany Auto Show spaces as the previous year, had Haynes, Allen and Standard cars. The new makes provided both a cheaper car (the Allen) and a more expensive one (the Standard) than the Haynes, although the Haynes and Standard models were not much different in price.

For 1916, the Haynes offered a "Light Six" and a new "Light Twelve," the cost difference between the two being \$400 for each body style, e.g., the "Light Six" five-passenger touring car cost \$1,485 and the twelve \$1,885. A fine, three-color booklet describing the new Haynes cars has the word "Copy" in Christian Weeber's handwriting three times each on the front and back covers. The Weeber business rubber stamp is present on the first inside page.

A "dealer's coin pass"⁸⁶³ for the National Automobile Show New York 1916" indicates that Christian Weeber traveled to New York for that event.

1917 Model Year

A display advertisement in the *Albany Evening Journal*, in conjunction with the annual Albany Auto Show, shows that the two Haynes lines, i.e., the "Light" sixes and twelves continued for 1917, albeit with higher prices, \$1,595 and \$2,095 respectively for the five-passenger touring cars. The *Evening Journal*, in commenting upon Christian Weeber's display of Standard, Allen and Haynes

⁸⁶²See, for example, the *Albany Evening Journal*, February 16, 1915, for an advertisement that advised readers that the Haynes, among other attributes, had the highest horsepower to weight ratio of any American automobile.

⁸⁶³Identified with those words by Marion Weeber. H-1970.110.7.

cars at the annual Albany Automobile Dealers' Association exhibition at the Washington Avenue Armory, said:

As the oldest automobile man in Albany, having in 1898 built and owned the first car in the city, it is only fitting that he should handle the Haynes, America's first car. Two of these famous light sixes are on exhibition in his booth, where they are attracting the attention of which they are deserving.⁸⁶⁴

The Argus ascribed to Christian Weeber, "distributor of the Haynes car in this locality," the statement at the auto show that the "South is buying more cars this year... than in any time in its history." Although the reason why Weeber would be recognized as an authority on the subject of southern auto sales is unknown here, the indirect quote concludes with the news that volume had increased by almost fifty percent. "The sounder financial condition of the States south of the Mason and Dixon line is largely responsible for the increased shipments."

On February 20, 1917, the *Albany Evening Journal* noted that the Weeber Works had sold a Haynes Touring Car to Dr. G. L. Bielby [sic].⁸⁶⁵

1918 Model Year

For 1918, five-passenger and seven-passenger Haynes Touring Cars, along with two Standard autos, were in the Weeber exhibit at the Albany Auto Show. Weeber employee, A. C. Dederick, told the *Albany Times Union*, his company had "sold 50% more cars this winter than last, with good prospects for plenty of spring sales." It was a positive and surprising report in light of the wartime conditions that often lead to shortages of material. Dederick continued to note, "There may be some delay in making deliveries but that can be overcome by running the cars through from the factory." Of the Haynes cars on display he said, "...both have long wheelbase with long flexible springs which give them easy riding qualities."⁸⁶⁶

⁸⁶⁴February 22, 1917. *The Argus*, February 22, 1917, repeats this text verbatim.

⁸⁶⁵City directories for 1916 and 1917 list physician Dr. George L. Beilby with an office and residence at 247 State Street.

⁸⁶⁶February 16, 1918.



Figure 9.7: Photograph of automobile dealers in New York, c. 1916. Automobile Dealers Convention New York City (taken outside hotel). Marion Weeber identified her father as “Chris Weeber—Front row, extreme right Derby, velvet collar overcoat, mustache, foot forward, fist hand.” In the front row, Weeber is the third man from the right. Photograph by N. Lazarnick. H-1970.110.49.



Figure 9.8: Weeber exhibit at the Albany Automobile Dealers' Association show, 1917. A Haynes Light Six touring car is prominent in the center. To the left of the Haynes, is Allen, another auto make sold at that time by the C.F. Weeber Mfg. Works. The *Albany Evening Journal*, February 24, 1917, said the Weeber display "was one of the largest exhibits at the show." NYSM Collection, H-2000.39.78.

The Argus said Christian Weeber's long association with Haynes created in him "a certain affection for the shiny bodied cars of that make in his exhibit." With a booth near the show entrance, "a good crowd is always gathered about the cars and Mr. Weeber has seen them slip one by one from his hands into the hands of buyers."

Later Weeber found the show had been "a gold mine for his sturdy [Haynes and Standard] cars."

Fine, that's all I can say for the way the show has been conducted. I have experienced the biggest business ever and look for its continuation, as a result of the show, for some time. I have opened negotiations for the sale of many of the cars in the exhibit and many more have already been sold. That there is any reluctance on the part of the people of Albany to buy automobiles seems far fetched when the record of sales is produced.⁸⁶⁷

World War I, as well as a factor in automobile production and distribution in early 1918,

⁸⁶⁷*The Argus*, February 21, 22, 23 and 24, 1918. On February 22, the newspaper said Weeber's, "Coles are right at the entrance to the show," mistaking that make either for the Haynes or Standard or both.

also affected car prices. In February, *The Argus* reported Haynes higher prices as of March 1. Weeber advertised that all Haynes cars would be \$125 more expensive as of that date. Pre-advance those prices ranged from \$1,725 for a six-cylinder, five-passenger touring car to \$2,785 for a twelve-cylinder, seven-passenger tourer, with these prices already subject to delivery costs plus a war tax.⁸⁶⁸ Christian Weeber also commented that an "automobile shortage" was expected in the spring. Weeber's information had come from S. M. How, Haynes general manager, who had written to describe a situation in which Eastern United States dealers had few cars on hand in spite of their starting the winter with a good supply. "The principal

⁸⁶⁸Haynes Automobile Company, *Haynes "America's First Car"* (Kokomo, Indiana, 1918), a Haynes catalogue, probably printed in the late winter or spring of 1918, includes a price list pasted in which reflects the \$125 increase, i.e., the six-cylinder, five-passenger touring car is listed at \$1,850 and the twelve-cylinder, seven-passenger tourer is \$2,910. The most expensive car, incidentally, was a town car at \$3,985. The war tax was \$47 on all models.

reasons for this condition has [sic] been the freight car shortage, aided by embargoes."⁸⁶⁹

In the Weeber collection at the New York State Museum, a twenty-page Haynes catalogue reflects the price increase. Distributed sometime between March 1 and July 4, 1918 (when "the Haynes institution will round out a quarter-century of constant progress"), the two-color booklet has the car prices on a slip pasted on the inside back cover, perhaps suggesting that at the time of publication the Haynes Company had allowed for future price changes. That slip of paper notes that "Demountable tops for open models, \$300 [see below]. To cover war tax, \$47.00 on all models." A Weeber Manufacturing Works rubber stamp marks the catalogue front cover.⁸⁷⁰

The Haynes Automobile Company published a monthly magazine, *The Haynes Pioneer*, largely as an advertising device. Among the objects in the New York State Museum's Weeber collection are a number of *Pioneer* issues depicting the 1918 Haynes models. Several of the magazines are stamped on their covers with the Weeber Works name and address, suggesting these issues were intended either for use in the Weeber show room or for distribution to customers.⁸⁷¹

A brochure in the Weeber collection at the New York State Museum promoted "Detachable Sedan Tops" for Haynes models 38, 39 and 44, i.e., 1918 models. Reflecting wartime conditions, the Haynes Automobile Company suggested that railroad schedules were "uncertain, trains are overcrowded, passenger traffic is disrupted. Business must suffer. . ." But using the automobile was an answer. "Use it now, as a patriotic duty. . ."⁸⁷² The key to driving in inclement weather, the Haynes Company suggested, was a detachable top. Whether for roadster or touring car, the top cost consumers \$300. Whether the Weeber Works sold any is unknown here.

The Hotel Woodward, at Broadway and 55th Street in Manhattan, printed a *Directory of Automob-*

ile Row,⁸⁷³ probably in 1918. This slight booklet lists the personnel of the Haynes Automobile Company of New York, both managers and salesmen. Among the former were E. W. Headington, president and manager; W. H. Webster, sales manager; E. Keller, wholesale manager; C. R. Senior, used car manager; and R. J. Oakes, service department manager. Perhaps the Weeber Manufacturing Works in this period had dealings with Keller as well as Headington.

1919 Model Year

At the annual Albany Auto Show in February 1919, the C. F. Weeber Manufacturing Works' Haynes display included "one of their first models," probably on loan from the Haynes Motor Company, as well as one of the latest twelve-cylinder Haynes models, "the perfection, one would think, of automobiles."⁸⁷⁴

In March 1919, S. M. How sent a broadcast "Special Trade Letter No. 24" to Haynes dealers pushing the sale of demountable tops and seat slip-covers. Apparently, typical of Haynes operations, such letters advised dealers of sale items and included a price schedule. For the removable hard tops, for example, the dealer cost for a 1918 Model 39 seven-passenger touring car was \$200. Retail was \$215. The markup on each top was \$15, while it was \$5 on each set of seat covers. Attached to the trade letter were sample letters to be typed on the dealer's letterhead and sent to potential customers with information about the tops. Whether Christian Weeber sent any such letters is unknown here and a section of the S. M. How letter in effect argued against doing so.

Because of the matter of time we are closing prospects direct from the factory. However, when we make a sale in your territory you will receive your profit.

Copies of prospect letters we receive will be mailed you for follow-up.

Every co-operation will be given you to close your prospects before the spring weather increases the resistance of demountable top selling.⁸⁷⁵

⁸⁷³H-1933.6.269. The back cover noted the hotel was "In the heart of the Automobile Section of New York City."

⁸⁷⁴*The Argus*, February 17, 1919.

⁸⁷⁵The Limousine Top Company of Kalamazoo, Michigan, also made accessory tops for open Haynes cars. Three

⁸⁶⁹*The Argus*, February 17 and 21, 1918.

⁸⁷⁰H-1933.6.325.

⁸⁷¹The *Haynes Pioneer* issues on hand are those for October 1917, January 1918, March 1918, May 1918 (three copies) and July 1918. That for July 1918 is marked "Published Monthly by the Haynes Automobile Company Kokomo, Indiana. . . vol. 6, no. 1." Subscription price was 25c per year. H-1933.6.356, 373, 374, 375, 377, 378, 391,

⁸⁷²H-1933.6.385.

Another advertising device that has been preserved in the Weeber collection is a series of nine different layouts on light paper sent to dealers for use in newspapers. Attached text advised dealers that a “mat or stereotype will be furnished gratis on request.” Also, attached was information about size, e.g., “Special newspaper copy number 4377—Size 150 lines by 3 columns.” The prices given in the advertisements probably reflect mid-year advances due to wartime increases. However, the advertisements for 1919 models are undated but “1919 finds the Haynes more popular than ever.”

1920 Model Year

The C. F. Weeber Manufacturing Works displayed Haynes cars at the Albany Auto Show in February 1920,⁸⁷⁶ showing a “Chummy Roadster” and a seven-passenger touring car. The former reportedly “came in for much favorable discussion” featuring “the lightness of the roadster and the durability of the touring car for touring and for city driving.” It was “finished beautifully” and had “all the modern conveniences.”⁸⁷⁷ Another observer thought the Chummy seating plan “promotes sociability.”⁸⁷⁸

A Haynes display advertisement in *The Argus* was keyed to the Albany Auto Show with a headline noting the “One Display You Cannot Afford to Miss is the Haynes Exhibit.” Readers were directed to “Exhibit 17-18” as well as “C. F. Weeber” at 168 Central Avenue (telephone West 460).⁸⁷⁹ A story likely distributed by the Haynes Automobile

brochures describing such tops are among Weeber artifacts at the New York State Museum. One of two identical brochures was mailed to the Weeber Works from Kalamazoo on December 17, 1918; the other has no address or stamp on it. The Limousine tops were more expensive than those distributed by the Haynes factory; \$350 for a touring car top. Limousine tops, made “for several leading makes of cars, your own included,” were intended to be permanently installed with the side panels removed for warm weather, if desired. The third handbill (H-1933.6.384) probably dates from 1918 and has information about tops for 1917 and 1918 models. The author does not know whether Weeber ordered any Limousine equipment.

⁸⁷⁶Albany Times Union, February 21, 1920.

⁸⁷⁷The Argus, February 25, 1920.

⁸⁷⁸Albany Evening Journal, February 28, 1920. “Chummy” usually denotes a front to back staggering of the seats.

⁸⁷⁹The Argus, February 22, 1920. The photograph in the advertisement shows a Haynes sedan rather than either of the show cars.

Company appearing in the *Albany Evening Journal* at the time of the show told of a California physician who, so satisfied with his 1915 model Haynes, refused to sell it back to the dealer for the original price. The last paragraph of the story added that “C. F. Weeber, the Albany representative of the Haynes car, attests to the marvelous performances of the machine.”⁸⁸⁰

A photograph of the Albany Automobile Dealers’ Association in 1921 includes Christian Weeber, although he was no longer a Haynes dealer; in fact no longer selling any new cars. Among the publications received from Pauline Weeber was an instruction booklet for the 1922 Haynes Model 75. Grease marks indicate use of the volume by a mechanic. Perhaps Haynes owners continued to seek out the Weeber Manufacturing Works, after many years of selling and servicing Haynes cars, even after other agents represented the Haynes Company in Albany.

Production for the Haynes model years during Weeber’s association with the Haynes Company, 1909-1920, has been recorded at: 1909, 363 cars; 1910, 1,083; 1911, 1,110; 1912, 1,310; 1913, 1,336; 1914, 1,883; 1915, 5,610; 1916, 9,813; 1917, 5,586; 1918, 2,236; 1919, 3,746; and 1920, 993.⁸⁸¹ What portions of these numbers were sold through the Weeber firm and its sub-dealers has not been discovered here.

⁸⁸⁰February 21, 1920. Also in the same edition of the newspaper was a C. F. Weeber Manufacturing Works (at 168 Central Avenue) display advertisement for Haynes “Character Cars.” The Weeber Collection at the New York State Museum includes a catalog of Haynes cars for the 1920 season.

⁸⁸¹Kimes, Beverly Rae, et al., *Standard Catalog of American Cars 1805-1942* (third edition, Iola, Wisconsin, 1996). Haynes production ended in early 1925.

CHAPTER 10. AGENT FOR THE JEWEL CARRIAGE COMPANY OF CARTHAGE, OHIO

In late spring 1909, Christian Weeber corresponded with the Jewel Carriage Company of Carthage, Ohio, about selling the Ohio automobile. The \$2,000, 35-40 horsepower touring car was available to the C. F. Weeber Manufacturing Works for a 20% discount. Jewel president, Charles F. Pratt, and treasurer, Albert. E. Schafer,⁸⁸² each sent several letters encouraging Weeber to order a demonstration car. At approximately twice the price of the Ford Model T, the Ohio would complement the Ford car line already offered by the Weeber Works.

By early June, Schafer had visited Albany and Weeber had begun to advertise the Ohio Model 40, although he did not yet have a car on hand. A large display advertisement, twice in *The Argus* and at least once in the *Albany Evening Journal*, alerted readers that, "We are able to make prompt deliveries of this splendid car."⁸⁸³ Schafer soon wrote that he regretted that Weeber had not "placed an order with me when I was there, because I feel positive had you done so and had the car on the floor by this time, that it's splendid value would have induced a ready sale and you would not only have had your profit, but been in shape to order more by this [June 16, 1909] time." Schafer wrote again in July repeating his regret that Weeber had not ordered a car when Schafer visited. In fact, in spite of Weeber's advertising for the Ohio, he apparently had not yet ordered a car at all. Schafer wrote:

We are having a splendid demand for the car from all sections and wish that we might have your order for a car to show in your prosperous community, when we feel sure that with our prompt deliveries, we could make you some good money before the season is over.⁸⁸⁴

Schafer's next letter, on July 13, told Weeber that a sales representative, Alexander Howell, had a demonstration car in Manhattan. Howell was to contact Weeber about a visit to New York. Weeber noted in pencil on Schafer's letter, "ordered 7/22." Pratt wrote Weeber on the 24th that a car would be shipped with Goodyear tires, since neither the desired Diamond or Goodrich were available. Terms of delivery required 20% attached." Weeber was requested to send an initial \$320 payment. He noted in pencil on Pratt's letter, "check sent 7/26" as well as "wired 7/26."

The Jewel Carriage Company bill to the Weeber Manufacturing Works is dated July 27, 1909. The Model 40 Ohio had chassis number 526 and engine number 2500. The cost was \$2,000 plus \$100 for a top all less 20% or \$420. Deducting the initial \$320 payment, \$1,360 was due by sight draft.

As the bill⁸⁸⁵ indicates, the car was shipped with a top, which Weeber had not ordered. Pratt acknowledged Jewel's error, asking Weeber to "[p]lay the draft and then decide what you want to do afterwards, we will be glad to refund for the top. It is our mistake in mis-reading your letter. It came in late Saturday and in order to get the job off quickly we rushed the order through the factory and this lead [sic] to a misunderstanding."⁸⁸⁶ Another glitch in filling the order was a missing tool

⁸⁸²Both Pratt and Schafer used only initials for their given names. Their full first names have been obtained from Cincinnati city directories. The directory issued in June 1909 has a paid notice for the Jewel Carriage Company as a "wholesale manufacturer of medium and high grade buggies, motor buggies and automobiles; capacity 20,000 vehicles annually." Into 1909, there was also a Jewel automobile manufactured by the Forest City Motor Car Company of Massillon, Ohio. See *The Horseless Age*, vol. 19, no. 23, June 5, 1907, pp. 747-748; Kimes, *op. cit.*, p. 784.

⁸⁸³*The Argus*, June 13 and 20, 1909; *Albany Evening Journal*, June 12, 1909. The advertisement apparently had been prepared by the Jewel Carriage Company for use by its dealers.

⁸⁸⁴A. E. Schafer to C. F. Weeber Manufacturing Works, July 3, 1909.

⁸⁸⁵The invoice and the sight draft survive in the Weeber collection at the New York State Museum. The latter is dated July 28, 1909, paid to the order of the Miami Valley National Bank in Hamilton, Ohio.

⁸⁸⁶C. F. Pratt to C. F. Weeber Manufacturing Works, July 28, 1909.

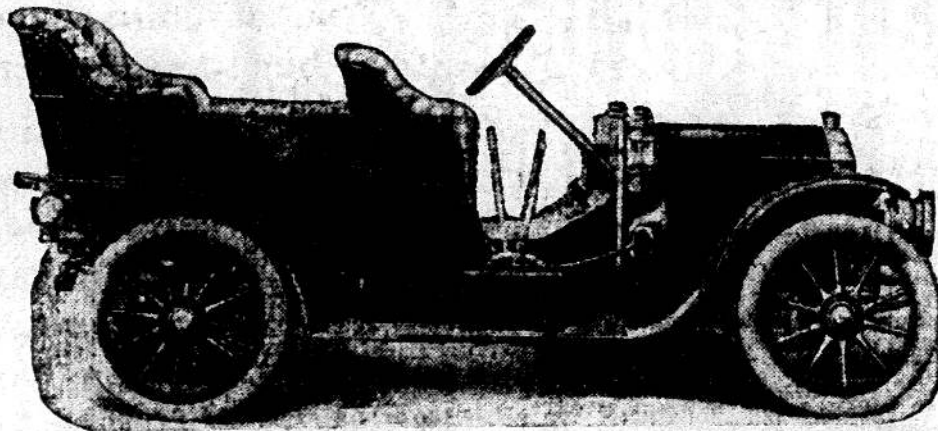

Ohio Model 40

Built on Integrity

35-40 H. P. \$2,000

THE OHIO is a car of honest, dependable value throughout. It will stand the most minute investigation—no matter how high your standards may be.

We are able to make prompt deliveries of this splendid car.

Motor: 35-40 horse power—four-cylinder, four-cycle, $4\frac{1}{4}$ inch bore by $4\frac{1}{2}$ inch stroke; thermo-syphon radiation with honey comb radiator; integral oiling system; speed, 4 to 50 miles an hour. *Transmission:* Nickel-steel, selective type, fitted with annular bearings; five disc (bronze and steel) clutch, with cork inserts; two universal joints on drive shaft.

Frame: Reinforced, cold-rolled steel, channel section, drop pattern. *Springs:* Semi-elliptic in front, platform springs in rear. *Wheels:* 34 inch by 4 inch, artillery pattern, fitted with quick detachable tires. *Wheel Base:* 110 inches. *Axles:* Drop forged "I" beam front, floating rear. *Brakes:* 12 inch internal expanding emergency brake; 12 inch external contracting foot lever brake. *Steering Gear:* Irreversible type with spring end connections to arms. *Electric Source:* Low tension magneto, coil and batteries. *Body:* Straight line with mahogany dash; very roomy five passenger tonneau (26 inches between seats); luxuriously painted and trimmed, heavily upholstered in finest grade leather. *Equipment:* Shock absorbers, large searchlights with gas generator, dash and tail lamps, large horn, jack, tool kit, pump and rubber repair kit.

C. F. Weeber Mfg. Wks.

172 Central Avenue

ALBANY, N. Y.

Figure 10.1: *The Argus*, June 20, 1909. Weeber Manufacturing Works display advertisement for the Ohio car. Courtesy of the New York State Library, Manuscripts and Special Collections.

kit; the Carriage Company quickly forwarded a second tool kit, “express all charges paid.”⁸⁸⁷ In late August, Jewel replaced a defective part of the emergency brake lever. “Kindly return defective one to us. We are also sending you 100 more circulars.”⁸⁸⁸

Inquiries at the factory about the Ohio car factory were brought to Weeber’s attention. R. Wilson Smart of Troy⁸⁸⁹ was one man interested in the car. Weeber noted on the letter from Pratt that, “Kinney [illegible?] said he will call,” and that he “wrote to Jewell [sic] 8/27.” The Albany Rubber Company was another interested party. Pratt advised, “Better see them.” Weeber noted, “Phone will let Ruo... [illegible?].” An undated clipping from an unidentified Albany newspaper printed sometime after June 1909 reports that the Weeber Manufacturing Works was an agency for the Ohio car.⁸⁹⁰

A story in the Albany *Times Union* for October 4, 1909, noted that the C. F. Weeber Manufacturing Works was the Albany agent for the Ohio (as well as for Ford cars and Chase trucks). Still, apparently, the end was at hand for the Weeber-Jewel business relationship. In September, Weeber ordered a runabout for October 15 delivery. On September 13, Pratt wrote that he could not accept the order or continue the Ohio agency for 1910 unless Weeber ordered a “certain number of cars. You can readily appreciate the fact that no one can afford to tie up the territory which we have given you on the basis on one car.” Pratt expected Weeber to commit to fifteen cars with a cash deposit of \$50 for each vehicle. “You have had our car now for several weeks, and know what it will do, and you know whether or not you want to continue the agency.”⁸⁹¹

Weeber replied on September 27,th to which letter Pratt responded on the 29th by returning Weeber’s check for the runabout. “We certainly would not make a contract for another 12 months on a ba-

⁸⁸⁷Edgar E. Muller to C. F. Weeber Manufacturing Works, August 7, 1909.

⁸⁸⁸Pratt to C. F. Weeber Manufacturing Works, August 28, 1909.

⁸⁸⁹The Troy city directory for 1909 lists Smart as a collar worker residing on Spring Avenue.

⁸⁹⁰The clipping, provided to the Museum by Marion Weeber in 1983, mentions the success of a coast-to-coast travel by two Ford cars, a trial that took place in June 1909 and is discussed elsewhere in this work.

⁸⁹¹Charles F. Pratt to Weeber Manufacturing Works, September 29, 1909.

sis of one car, much as we would like to have you handle our machine... We don’t think we are taking an unfair view or are treating you unfairly... If you think you are not treated properly come down to see us next week at the [carriage dealers] New York show... Come down and see us and we will go over these matters candidly and fairly.” With only a pencil mark of acknowledgement on the document by Weeber after seeing Pratt’s letter and a lack of further correspondence from the Jewel Carriage Company, this final communication apparently marks the end of Weeber’s Ohio automobile endeavor. What disposition was made of the Ohio touring car has not been determined here.⁸⁹² By the summer of 1911, the Troy Carriage Works in “Upper Troy” was an agency for the Ohio as well as Speedwell and Mitchell automobiles.⁸⁹³

Perhaps the fact that Weeber was arranging to sell the Haynes automobile figured into his decision to sever ties with the Jewel Company. While for 1909 the Series X Haynes touring car had listed at \$3,000, for 1910, the first year of Weeber’s sale of the Haynes, the Model 19 was only \$2,000. For the same price as the Ohio, a Haynes customer was offered a 36-horsepower car on a 110.5-inch wheelbase, both figures comparable to the Ohio 40. Although in 1909, the Ohio would have filled a thousand dollar increment gap between the \$850 Ford T touring car and the \$3,000 Haynes X for 1910 in the offerings of the C. F. Weeber Manufacturing Works for the Ohio was redundant.

⁸⁹²In 1914, an Ohio automobile was registered with plate number 78220 by Morris J. Davies of Utica. See J. R. Burton & Co., *Official Automobile Directory of the State of New York* (New York, 1914).

⁸⁹³See a Troy Carriage Works advertisement in the 1911 Albany city directory. The Troy firm also sold Kelly and Speedwell trucks from its Third Avenue and 21st Street location.

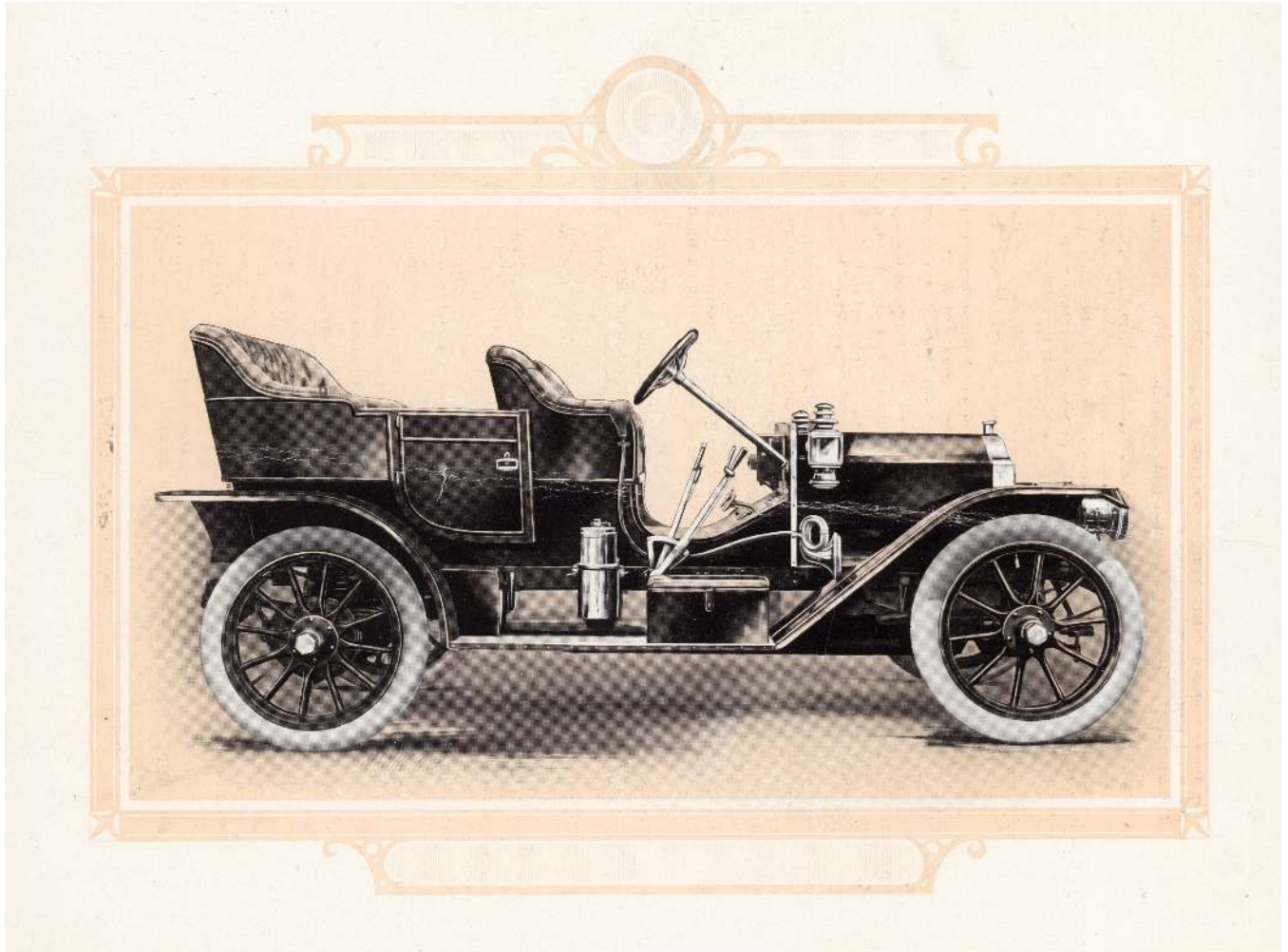

Figure 10.2: Jewel Carriage Company's brochure, c. 1909. The engraving from the Ohio circular shows the Ohio 35-40 horsepower touring car. The body of the four-cylinder car was painted "Ohio red, deep and rich, with black mouldings and black stripe on gear." Standard equipment included the horn, tool kit, pump, jack, "rubber repair kit" and all the lamps. The headlights were called "extra size search lights with large size mirrors." NYSM Collection, H-1933.6.NN.

CHAPTER 11. AGENT FOR THE E-M-F COMPANY OF DETROIT, MICHIGAN AND THE STUDEBAKER BROTHERS COMPANY OF NEW YORK, NEW YORK (SUBSIDIARY OF STUDEBAKER BROTHERS COMPANY OF SOUTH BEND, INDIANA)

1911 Model Year

In the late winter of 1910, Christian Weeber may have hinted that his days as a Ford dealer were ending. Speaking with a reporter for the *Sunday Press*, Weeber said that while he looked forward to a prosperous year “and that his orders showed an increase over last year:”

I consider the automobile business still in its infancy...and capable of much greater development. Farmers in particular are now buying three times as many machines as they did last year. I should say the tendency of the business is now toward the medium priced machines, from \$1,000 to \$2,000. These cars are well made and are proving very satisfactory. The cheaper grades [such as Ford?] are not able to stand the competition and will not be on the market long. The repairing business is on the increase and will be for while, and then, when only the better grades of cars are used, there will not be as much repairing to be done.”⁸⁹⁴

In the winter of 1910 Christian Weeber negotiated regarding several cars he wanted to sell to the Krouse Motor Car Company in Philadelphia, Pennsylvania, a firm claiming to be the “largest dealers and brokers of automobiles in the world.” On February 2, the Krouse Company wrote:

Your letter of the 1st inst. at hand. Will you please let us know how far are we off from the figures you wish to sell your cars for. It is a difficult matter to give a correct estimate on cars you have not seen so if you will write

us and give us you bottom figures we may be able to transact business with you.⁸⁹⁵

An undated inventory of cars typed on Weeber Manufacturing Works letterhead apparently dates from this period. Perhaps it is the list shared with the Krouse Company but the writer has no way to connect positively the Krouse letter and the surviving document.

Beside each of the autos listed on the surviving document, two figures are written in pencil, apparently high and low values. The numbers are totaled at the bottom of the list. Pencil notations near the bottom of the paper read, “Ads 50” and “Buick [or Brush] 350.” Additional pencil figures tie specific cars via pencil lines running from outside the main body of the list. That list reads:

1	1906	Corbin touring car,	500-450
1	1907	Haynes “...”	800-600
1	1906	Maxwell runabout,	350-250-275
1	1909	T Ford coupe,	600-500-550
2	1908	S Ford roadsters,	850-800
4	1908	S Ford roadsters,	1500
1	1909	Chase Truck Model O	550-500
1	1909	T Ford touring car,	700-700
2	1909	T Ford tourabouts,	1400-1400
1	1909	T Ford tunabout, [sic]	650-600
2	1907	R Ford runabouts,	650-600
			7050 6400 ⁸⁹⁶

Of the cars on the Weeber list, one wonders whether the Maxwell might be the same used car about which Weeber had written the previous year and if the Corbin was that purchased by Emil Weeber in 1906 from the Central Automobile Com-

⁸⁹⁴The *Sunday Press*, March 6, 1910.

⁸⁹⁵The writer’s signature is partially illegible. It may read, “Jas M. Laughl...”

pany. The Ford T coupe was an extremely poor selling vehicle. Perhaps this was the same car shown in the photo of the Weeber Manufacturing Works building on Central Avenue. The T Tourabouts were much less popular than the touring cars. Some months later in 1910, as will be seen below, Christian Weeber sent a list (whether the same or a different one is unknown here) of cars to a different agency for the disposal of vehicles he had on hand.



In the summer of 1910, Christian Weeber communicated with the New York office of the Studebaker Brothers Company of South Bend, Indiana about becoming a dealer for E-M-F and Flanders cars. The E-M-F was a product of the E-M-F Company of Detroit, a company recently acquired by the Studebaker Brothers Company.⁸⁹⁷ The Flanders operation, owned by the Studebaker Brothers Company, also was located in Detroit.

The Studebaker Brothers Company, directly or through subsidiaries, such as the Studebaker Brothers Company of New York, distributed both makes; the E-M-F being a more expensive (\$1,000) car than the Flanders (\$800). During the 1909 and 1910 model years, E-M-F and Studebaker cars had been sold by the Albany Garage on Howard Street. Indeed, the Albany Garage had at least one sub-agent, Daniel H. Cowles in Glens Falls.⁸⁹⁸ The Albany Garage Company displayed E-M-F and Flanders (Studebaker) cars at the Albany auto

⁸⁹⁷*The Motor World*, March 10, 1910, vol. 22, no. 10, reported "Studebaker Buys E-M-F." While Studebaker had owned 36% of the E-M-F stock, the companies had been involved in litigation. E-M-F reportedly had refused to supply Studebaker with cars and was appointing its own agents.

⁸⁹⁸*The Argus*, January 3, 1909, noted that the Albany Garage had a successful holiday season selling E-M-F and other cars. On January 10, 1909, the paper reported, "There is a waiting list of automobile enthusiasts waiting to take their turns at the E-M-F demonstrators." On January 17, the paper reported that "Cowls," as sub-agent for the Albany Garage, had sold three cars "last week and reports automobile interests lively in that town." On January 31, the newspaper reported more E-M-F sales at the Albany Garage. In June 1909, the Albany Garage advertised that it was agent for Peerless, Simplex, Aperson, Palmer & Singer, Studebaker and E.M.F. cars. See *The Argus*, June 6, 1909. In May, the Garage delivered three E-M-F cars to Cowles. See *The Argus*, May 16, 1909. The 1909-1910 and 1911-1912 Glens Falls directories list the Empire Automobile Company at 45-47 Warren Street with Daniel H. Cowles as president. The makes of cars sold are not shown.

show in March 1910.⁸⁹⁹ Later in 1910, however, Albany Garage advertised only Peerless and Simplex autos, having given up distribution of Studebaker cars or having been dropped by the Studebaker Brothers Company.

A two-page letter to "C. F. Weeber" from W. J. Donlan of the automobile department of the Studebaker Brothers Company of New York, on August 31, 1910, delineated the reasons why Weeber should become a Flanders and E-M-F agent. Referring to the "present condition of the financial market and the apparent future of some of the automobile manufacturers," the writer advised that the potential agent for a 1911 line should seek one. . .

. . . that will continue to be manufactured for some years to come, because you know very well that it's an expensive proposition to work a year or two on one car, drop it and work a year or two on some other car, and then drop that owing to the fact that company goes out of business or is absorbed by some larger concern.

Were Weeber to become a Studebaker agent, he would have dealt with the Studebaker Brothers Company of New York rather than with the Indiana factory. His contacts in New York, with the largest parts supply of any manufacturer in the city, would know him personally so that he would not have to worry about dealing with strangers "a thousand miles away." The advantage would be "about the same as the friendly greeting you get at your club, in comparison to the icy stare of the 'cheap' hotel clerk as you look across the register at a strange hotel." Donlan noted that he was sending, at "the request of Mr. Bittig," a "complete list of literature on E-M-F and Flanders cars." Weeber marked the letter, "wrote 9/6 Copie [?] attached [?]."

By early autumn 1910, Weeber had committed to giving up his Ford agency and adding Studebaker-distributed cars to his C. F. Weeber Manufacturing Works automotive offerings. Apparently during the negotiating period with Studebaker, Weeber was concerned about the disposition of some automobiles he had on hand in Albany and arranged to ship them to the Studebaker Brothers Company of New York for sale. While the exact understanding

⁸⁹⁹*Albany Times-Union*, March 5, 1910. The Albany Garage Company also exhibited Peerless and Simplex cars at the auto show.

is unclear, given the absence of outgoing communications from Weeber, a late September 1910 letter to him from C. [Charles] A. Redden, manager of the Studebaker automobile department, indicates that vehicles were on their way to New York.

Your telegram just at hand, and I will make arrangements to get the cars up here as soon as they arrive and have them put on the sales floor without delay, and will try to do something on them to-morrow as the town is absolutely packed with auto fanatics coming to this race.⁹⁰⁰

Redden noted in his letter that he was sending some E-M-F and Flanders advertising material to Weeber's house rather than the Manufacturing Works, "so that until you notify us there will be no occasion for any employees at your office to know of the change you are making." Apparently, Redden had been in Albany, or Weeber had been accompanied by his wife in a trip to New York, as the new business relationship was established, for Redden ended his letter by stating his thought that "the connections we have just established will result in a pleasant and successful business future for you" and extending "best good wishes, and my respectful compliments to Mrs. Weeber [sic], believe me."

It appears that Redden's letter and one from Weeber, both dated September 30, crossed, since on October 4, Redden's colleague, C. M. Kraham, wrote to Weeber acknowledging the Weeber communication and telling him that "the two cars mentioned in your letter have been received, and we shall take pleasure in putting forth every effort possible to dispose of these for you at the prices which you have named."⁹⁰¹

On October 15, Kraham wrote again asking for the prices "we should get for cars you recently sent us" since the original list had been misplaced.⁹⁰² Whether the desired sales took place has not been determined here. On the other hand, in the next few months Weeber traded a Ford Model T with the Studebaker Brothers Company of New York, perhaps one of the cars in question for an E-M-F. The Company also "presented" him with three runabouts (two Fords and a Maxwell), "all

his property." Whether any of these vehicles were among those on the list reproduced above is unclear but seems likely since that list includes two Model R Fords and one Maxwell, all runabouts.⁹⁰³

The Studebaker Company felt that Weeber could have been quicker to start work as a Studebaker agent. A Studebaker Brothers telegram dated October 11 claimed, "Every moments [sic] delay with you means your [sic] losing sales... it is very important that you get busy quick so that we can announce you as our agent and sell cars in Albany. Please wire when you will be ready [sic] New price is putting it ever with a rush." Weeber noted on the telegram in pencil, "wire 10/12 12 30 noon." Still Redden was concerned. On October 15 he wrote, "I have been away a great deal of the time since I saw you... but have just returned and learned that you have not yet taken your demonstrating car..."

Redden continued by claiming that there would be a shortage of E-M-F cars in the spring "since there will be about half as many people in the business making them as there were last year." He advised that effort be made to sell cars in the fall. Redden wanted to "impress on you the importance of getting your demonstrator in there as soon as we can ship it, so that we can send a man up there to help you go round the county and place a sub-agent in every little town."

At \$1,000, the E-M-F supposedly was a good a car as any other that might be available at \$1,250, in the spring, so that if a buyer wanted to store the car for the winter at 1.5%, he would still be ahead. Redden concluded by stating he hoped Weeber would "understand the spirit of this letter" and send "shipping orders for your demonstrator immediately."⁹⁰⁴

The earliest surviving invoice for Weeber's order of an E-M-F car is that dated November 9, 1910, when he traded a Ford T Model. The E-M-F touring car he received cost him \$820, a 15% discount from the \$1,000 list. A top and a windshield were discounted 20% from the \$80 cost. He was billed

⁹⁰⁰Redden to C. F. Weeber, September 30, 1910.

⁹⁰¹Kraham to C. F. Weeber Mfg. Works, October 4, 1910.

⁹⁰²Kraham to Weeber, October 15, 1910. Weeber noted on the latter, "sent 1/-25 in Donlon [illegible?] letter."

⁹⁰³The November 9, 1910, invoice notes that Weeber purchased a \$1,000 (less agency discounts) E-M-F touring car for \$126.75 plus a Ford T car in exchange. An invoice from December 19, 1910, lists the return of three cars, "all his property." Both Studebaker Brothers Company of New York invoices were addressed to C. F. Weeber, rather than the C. F. Weeber Manufacturing Works, at 170 Central Avenue in Albany.

⁹⁰⁴Redden to Weeber, October 15, 1910.

\$22.75 for freight, probably from New York City.⁹⁰⁵ A second invoice from the Studebaker Brothers for an identical car, with motor number 18150, dates from November 21, 1910. It is marked "Paid Nov. 23, 1910."

The earliest invoice for a Flanders is for a \$700 roadster on which Weeber received a 15% discount. Top and windshield were discounted 20% of \$55. The entire \$661.75, including \$22.75 for freight, was marked by Weeber, "Pd. 12/9 [1910] by Draft."⁹⁰⁶

The earliest surviving contracts between C. F. Weeber himself (rather than the C. F. Weeber Manufacturing Works) and the Everitt-Metzger-Flanders Company of Detroit and the Studebaker Brothers Company of New York, date from December 6, 1910. These are both for the selling territory of "Columbia County, State of New York," differing in that one is for E-M-F "30" and the other for Flanders "20" cars. For the manufacturer, the contracts were signed by G. E. Kelly, general sales manager of the Everitt-Metzger-Flanders Company, and by F. E. Fisher, assistant to the president. C. A. Redden was the signer for the Studebaker Brothers Company of New York

Weeber agreed to buy six E-M-F cars, all with tops and windshields, to be delivered one each in December 1910, January 1911 and February 1911, with the remaining three in March. All but one, a demi-tonneau, were to be touring cars and be shipped from New York. Given appropriate notice, all orders were subject to change on Weeber's part.

Weeber agreed to forward a \$150 good faith deposit. In return, he was entitled to an 18% discount from the \$1,000 list price on each car. A sliding scale increased the discount to 19% for six to eleven cars and extended to 26% for sale of 48 or more vehicles. Weeber marked in pencil on the contract an "X" over the December delivery, suggesting, possibly, that he omitted that car. He circled the four other delivery dates, perhaps indicating that those were to be accepted. He wrote "Hallenbeck" next to the February delivery and "1 car for Mr. Herick" next to the March schedule. He also noted "Extra 1 Roadster 2 Tourings."

⁹⁰⁵The November 9, 1910, invoice is stamped "Paid" with a November 15, 1910 date.

⁹⁰⁶The invoice is dated December 5, 1910.

The Flanders contract, requiring a \$100 deposit, involved four roadsters, none of which had a top or windshield. One car was to be sent from New York in the second week of January; one in the second week of February; and two in the second week of March. Weeber noted in pencil adjacent to the February schedule "Hallenbeck" (probably Charles Hollenbeck, his Cobleskill sub-dealer). For the March deliveries he wrote, "set back to later date." His discount from the \$700 car list price was 15%. Parts were to be discounted 25% except tops and windshields, which were 20% less than list.

In January 1911, Weeber was billed for several E-M-F parts (all at 25% discount), suggesting that he was active in the repair of E-M-F and Flanders cars at that point.⁹⁰⁷ During the winter of 1911, Weeber purchased one Flanders Model 20 Suburban, two Flanders roadsters, one E-M-F Model 30 demi-tonneau and five touring cars. All vehicles were shipped with tops and windshields at extra cost. In all, the E-M-F Company billed Weeber for \$7,829.25. While most of the cars were shipped to Weeber in Albany, several went to his sub-agents at other destinations, specifically an E-M-F touring to Charles Hollenbeck in Cobleskill and an E-M-F touring car together with the Suburban to Frank S. Pulver at Boston Corners. All the invoices designate the railroad companies involved in getting the automobiles from Detroit to their final New York destinations. A cash on delivery invoice from the Studebaker Brothers Company of New York for delivery to Weeber of a Flanders 20 four-door touring car notes a freight charge of \$25 for shipment from Detroit to New York. With a 15% discount on the \$800 car, plus 20% on the combined \$80 top and windshield prices, on May 20, Weeber was billed \$769, a sum marked paid the same day.⁹⁰⁸

1912 Model Year

For the 1912 model year, a dealer's agreement between the C. F. Weeber Manufacturing Works (rather than for Christian Weeber as in the year before) and the Studebaker Corporation, granted selling rights for Albany, Schoharie and Columbia

⁹⁰⁷Weeber marked all three invoices in pencil, "Pd. 2/13/11." One bill was for a left hand rear fender for a 1910 Model E-M-F.

⁹⁰⁸These documents are part of the Weeber collection at the New York State Museum.

counties for the period of September 1, 1911 and August 1, 1912. The Weeber concern was to buy fifty each of E-M-F and Flanders cars to be shipped between September 10, 1911 and July 10, 1912. Of these vehicles, forty were to be E-M-F touring cars; 36 Flanders touring cars; and the remainder a mixture of demi-tonneaus, roadsters and four-passenger open Flanders cars. All vehicles were to be shipped with tops, windshields and speedometers.

Christian Weeber, who signed for the Weeber enterprise, agreed to make a deposit of \$600 to guarantee payment for repair parts. He was to benefit from a sliding scale giving his company a discount of between 18% and 23% on the list prices of automobiles and parts, depending upon how much he had purchased from the Studebaker Company. For example, for purchases up to and including \$10,000, the 18% discount was in effect. Between \$10,000 and \$20,000, 19% could be subtracted from Weeber purchases.

The contract has a typed paragraph under a "Remarks" heading:

It is understood and agreed by the C. F. Weeber Mfg. Works that they will establish a branch in Columbia County, at Hudson, N.Y., also sub-agencies in upper and lower sections of Columbia County, probably at Kinderhook and Ancram Lead Mines; also will establish sub-agent at Ravena in Albany County; also secure sub-agent in Schoharie County at Cobblestill [sic] and any additional sub-agencies necessary to fully develop entire territory.⁹⁰⁹

Two Studebaker sub-dealer agreements survive for the 1912 model year. Signed by Weeber, by Redden for the Studebaker Brothers Company and by the sub-dealers, the agreements gave the last discounts of 16% on new car prices up to purchases of \$10,000 with a sliding scale giving a 21% discount "at net prices in excess of \$50,000." Apparently, then, Weeber received 2% of the selling prices received by his sub-dealers.

For 1912, F. [Frank] S. Pulver of Ancram Lead Mines contracted for eight E-M-F and four Flanders cars to be sold in the lower part of Columbia County "below Hudson to a line drawn to Philmont." Pulver agreed to keep on his showroom floor one of each car make "during contract

if same can be had from factory." He also agreed to deposit \$300 as "a guaranty for the payment of his repair parts account, and to avoid the necessity of C.O.D. shipments of such repair parts...The Dealer agrees to account to the Sub-Dealer for such sum upon the expiration of this contract."

The issue of territoriality was examined and delineated in an extended paragraph. Pulver agreed not to sell to buyers outside his territory:

...except that should any person or persons residing outside his territory come unsolicited to the Sub-Dealer's place of business, sales may be made for delivery of cars off the floor to such persons and not otherwise, and in all such case the Sub-Dealer hereby agrees that he will pay to the Dealer or Sub-Dealer in whose territory the purchaser resides, one-half of the net profit represented by the difference between the regular list selling price of the car, parts and accessories, plus freight and the net cost to the Sub-Dealer of the car, parts and accessories plus freight...

The second contract was with George H. Brown and Brother of Kinderhook for the upper part of Columbia County "above Hudson and Philmont." This agreement also was for twelve cars, eight E-M-F and four Flanders, with shipping dates ranging from October 1911 through July 1912. The contract was signed by Redden, Weeber and George H. Brown. Weeber noted in ink, "Remarks It is agreed that the Paterson cars can be handled with above CFW."⁹¹⁰

There was no Albany auto show in 1912. Christian Weeber, however, promoted his Studebaker line elsewhere. For example, large display advertisements in the *Knickerbocker Press* in April included images of the Flanders 20 touring car and lengthy texts obviously prepared by the Studebaker Corporation.⁹¹¹ One advertisement (April 12) noted the Flanders was a car with international appeal. The E-M-F 30 was "made for American roads... [But the] '20' accurately conforms to European ideals and engineering standards—and in competition with their own it sells as fast we can

⁹¹⁰The Paterson was the product of the W. A. Paterson Company of Flint, Michigan. Manufactured from 1909 to 1923, production for 1911 totaled only 293 cars and 424 for 1912. See Kimes, *Standard Catalog*. As noted above, Weeber's erstwhile partners, Willard J. and Harry L. Sutherland, sold Paterson cars in 1911 at their Central Automobile Company on Quail Street in Albany.

⁹¹¹April 15 and 27, 1912.

⁹⁰⁹Weeber collection, New York State Museum, H-1970.110.17D.

supply them." Potential buyers were advised to secure a Flanders 20 quickly "else you will surely be disappointed, as more than 10,000 persons were a year ago." Only at the bottom of the advertisement did the Weeber Manufacturing Company [sic] name appear in type smaller than that for the Studebaker Corporation. A smaller but still substantial newspaper advertisement in early May incorporated a coupon addressed to the "C. F. Weeber Mfg. Co." The text of the ad and the coupon, clearly produced by the Studebaker Corporation, advised the reader to return the coupon so that he could learn "how you think a man ought to buy a car, if he wants his money's worth."⁹¹² Other Flanders display ads in the *Knickerbocker Press* followed on May 8, 11, 14, 18 and 22, 1912. On May 18, the almost a half-page display included the line, "To Publisher—Insert local dealer's name, address, and telephone number,"⁹¹³ indicating that the extensive advertising campaign likely was funded almost, if not entirely, by the Studebaker Corporation.

In April 1912, Christian Weeber's long-time acquaintance, Fletcher W. Battershall, his erstwhile partner in the shock absorber venture, registered an E-M-F car, one assumes he purchased from the Weeber Manufacturing Works. Among other Albany drivers of Studebaker cars in 1912 were G. Shepard King of 208 North Allen Street, who registered an E-M-F during the second week of April; and Charles L. Underhill of 322B Hamilton Street, who registered a Studebaker. If these were new cars, then it's likely that King's and Underhill's autos were purchased from the Weeber Manufacturing Works. Schenectady and Rensselaer counties, on the other hand, while also home to new registrants, were in different distributing agents' territories.⁹¹⁴

Two weeks later, Albany county residents registering Studebaker-made cars included: Edward J. Bedell of Delmar (Studebaker); Conrad Fox of 274 Third Street in Albany (E-M-F); Howard F. Hills, 101 Columbia Street (E-M-F); and Mary B. Searle of Watervliet (Studebaker). Additional buyers again were reported in Schenectady, Rensse-

laer and Saratoga counties, among them Christian Weeber's brother, Louis F. Weeber of Schenectady.⁹¹⁵ One assumes he acquired his car from Christian rather than from an agent in his home city. If indeed, there was a Studebaker agent in Schenectady, then Christian paid the "Dealer or Sub-Dealer in whose territory the purchaser resides, one-half of the net profit represented by the difference between the regular list selling price of the car, parts and accessories, plus freight and the net cost to the Sub-Dealer of the car, parts and accessories plus freight..." as noted above. At the end of the month or the beginning of May, Albany County Studebaker registrants were Schuyler Crouse of Voorheesville (Studebaker); Charles D. Niver of South Bethlehem (E-M-F); James Cummings of Voorheesville (E-M-F); and John C. Failing of 206 State Street in Albany (Studebaker).⁹¹⁶ Also in May, William H. G. Heffner of 119 Third Avenue in Albany, Albert G. Tanner of Cohoes and John B. Alix of Green Island, all registered Studebaker cars. William R. VanAlstyne of Kinderhook licensed an E-M-F.⁹¹⁷

An interesting artifact of Christian Weeber's experience as a Studebaker agent hides in the covers of *The Haynes Pioneer* for March 1916, a publication of the Haynes Automobile Company, whose cars Weeber also sold. Inside those covers actually is a parts book for the Studebaker 30 for 1912 and previous years. The cover also is marked "EMF-30" in pencil, indicating, of course, the earlier trade name for the car. The cover also is rubber stamped "C. F. Weeber Mfg. Works," indicating that the object was intended to be associated with the Weeber firm. Heavy soiling of the pages and price corrections written in both suggest this booklet was the working shop copy for the Weeber firm as it repaired Studebaker and E-M-F cars.⁹¹⁸

Other reference materials from the 1911-1912 or even 1911-1913 period in the Weeber collection at the New York State Museum include a Flanders 20 *Price List of Parts* for the "Model 'S' Flanders '20.'" This booklet, a well-used document of 78

⁹¹⁵*Knickerbocker Press*, April 21, 1912.

⁹¹⁶*Knickerbocker Press*, May 5, 1912.

⁹¹⁷*Knickerbocker Press*, May 12, 1912.

⁹¹⁸H-1933.6.376. Any title page, if there once was one, is missing. Page 51 is marked in pencil, "A B Colehammer 385 River [street] Troy, N.Y." Perhaps this refers to a Weeber customer. The Troy city directories for 1913 through 1915 list Alvah D. [sic] Colehammer, a salesman living at 6 Grand Street.

⁹¹²*Knickerbocker Press*, May 4, 1912.

⁹¹³The Weeber Manufacturing Works telephone number was West 460.

⁹¹⁴The list appearing in the *Knickerbocker Press* for April 14, 1912, does not indicate if new or used cars were being licensed.

glossy pages, may refer to 1910 or 1911 models since the images of complete cars show doorless front seating areas.⁹¹⁹ A second, coverless, incomplete, different price list is for the "20" renamed as the "Model 'S' Studebaker '20.'" This combination of parts photographs and lists is an even greasier and shabbier booklet with many price corrections and such notes as "cannot furnish" written in by hand in ink.⁹²⁰ The author assumes this second price list dates from the 1912 calendar year since recent authorities have noted that the smaller 1913 Studebaker car was known as the SA 25.⁹²¹

More definitively focused on the 1912 model year are four catalogues for Studebaker cars. Preserved until 2000 by the Weeber family were two identical "Studebaker E-M-F 30" 1912 "Preliminary Catalogue[s]; a "Studebaker Flanders 20" 1912 "Preliminary Catalogue;" and a "Flanders 20 Motor Cars" catalogue for 1912 depicting various "Studebaker 1912 Model Flanders '20'" cars.⁹²²

In May 1912, Redden visited Weeber in Albany. Interviewed by the *Times Union*, Redden spoke about the coming vast market for light (750 pound payload) delivery trucks to replace horse-drawn wagons. There were some 321,400 such wagons in use in four eastern states alone. Of course, Redden spoke of the Flanders truck, with Studebaker "building 30,000 of these chassis to fill our 1912 orders." Weeber "bore out Mr. Redden in his belief in the future of the light delivery car with a statement that tremendous interest has been aroused by the Flanders model he has shown here."⁹²³

A month later, Redden, "considered a fixture with the Studebaker corporation, [sic] being the dean of the automobile branch managers and having made up an enviable record in building up their business throughout the territory controlled by the New York branch," resigned to become New York and New England sales manager for the Metzger Motor Company's Everitt car. At Studebaker, Redden had been "unusually successful and attributes it to his policy of fair treatment to the agents and to protecting their interests and demanding they get a square deal, and as a re-

sult he is popular with his dealer and agents."⁹²⁴ Christian Weeber henceforth dealt with others at the Studebaker branch. His contract for 1913 was signed by E. R. Benson for the New York office.

1913 Model Year

The 1913 year marked a transition from Studebaker's distribution of E-M-F and Flanders automobiles to selling cars carrying the Studebaker name. In September 1912, Christian Weeber, for the C. F. Weeber Manufacturing Works, signed a contract with the Studebaker Corporation of America for 135 cars. Five were E-M-F Model 30 and five were Flanders Model 20 autos, possibly produced for the 1912 model year. They were to be shipped in September and October 1912.⁹²⁵ The other deliveries were to be Studebaker "35" (62 cars); Studebaker "25" (42 cars); and Studebaker "Six" (12 cars), all to be shipped between November 1912 and the end of July 1913.⁹²⁶

Weeber's selling territory was all of Albany, Schoharie, Columbia and now also Schenectady counties. He was to make a deposit of \$775 as a guaranty for payment of his repair parts account. He was to enjoy a 20% discount on purchases up to \$10,000 with a scale sliding to 25% for purchases over \$50,000. Weeber agreed to keep one automobile in stock.

In December 1912, Weeber received a copy of a statement signed by E. R. Benson for the Studebaker Corporation and by Weeber for the Weeber Manufacturing Works, noting an order change in

⁹²⁴*Knickerbocker Press*, June 12, 1912. Redden is identified in the story as Charles F. Redden. Barney Everitt and William Metzger, of course, are the "E" and the "M" of the E-M-F auto. Walter Flanders eventually rejoined his erstwhile partners, although the new Flanders Motor Car Company and the Flanders (the renamed Everitt) lasted only into 1913. See Kimes, pp. 552, 567.

⁹²⁵It is possible that some of the Flanders cars were sold as the Studebaker 20.

⁹²⁶Two parts books in the Weeber collection at the New York State Museum, H-1933.6.242 and 283, attest to a renaming of the Flanders 20. One is imprinted with the Flanders name. The other, lacking the title page, is for the Studebaker 20. The parts and parts numbers generally are identical except that the numbers for the Studebaker version have an "S" prefix, e.g., "1370" is the roadster top in the Flanders book; in the Studebaker book the number is "S1370." Additional ex-Weeber parts books for 1913 Studebakers are H-1933.6.220 for the Model "AA" 35 and Model "E" Six as well as H-1933.6.287 for the Model SA "25."

⁹¹⁹H-1933.6.243.

⁹²⁰H-1933.6.282. Pages missing include those before 15 and after 106.

⁹²¹Kimes, p. 1414.

⁹²²H-2000.39.90, 91, 89 and 92, respectively.

⁹²³May 18, 1912.

the shipping of four each of the E-M-F and Flanders cars and ten Studebakers. The Weeber deposit was to be "decreased in accordance with the above modification to the amount of \$675."⁹²⁷ In February 1913, Weeber was sent a copy of addenda to his contract along with a \$100 check "to take care of the difference in deposit."

In November 1912, Weeber received four separate letters from F. L. Sanford, assistant manager of the Studebaker branch in New York. Each was accompanied by a signed contract with a sub-agent for Weeber's operations in 1913. These sub-agents were Frank Fonda for the city of Schenectady; George A. Brown & Brother of Kinderhook; W. D. Young of Cobleskill; and Snyder Brothers of Ravena.

Fonda, who had all of Schenectady County as his territory, agreed on September 11, 1912, to buy 28 cars: 12 Studebaker "35" touring cars; 12 Studebaker "25" touring cars; 3 Studebaker "Six" touring cars, one each of E-M-F and Flanders touring cars; plus three delivery trucks. He deposited \$250 with Weeber and benefited from a sliding discount ranging from 16% to 21% on net prices over \$50,000. In addition to Fonda's and Weeber's signatures, the contract was signed by G. H. Phelps, Studebaker branch manager, who recommended acceptance by the Studebaker Corporation and E. R. Benson as sales manager.

Young's contract is dated November 1, 1912. In it he is given selling rights in the towns of Sharon, Carlisle, Esperance, Seward, Cobleskill, Schoharie, Wright, Richmondville and Middleburg in Schoharie County. He agreed to take fifteen Studebaker touring cars (seven "35s", six "25s" and one "Six") between the beginning of January and the end of July 1913.

On November 8, 1912, Snyder Brothers, given the town of Coeymans in Albany County, agreed to purchase ten cars (five each of "35" and "25") between November 15, 1912 and July 31, 1913. All were to be equipped with top, windshield, speedometer and Prestolite tank. Snyder Brothers were to keep one car in stock. Fonda and Young were to keep two Studebakers on hand.

⁹²⁷The statement is not explicit whether these cars were shipped or the orders were cancelled. The statement is dated December 26, 1913, but the author believes this was an error and the actual date was December 26, 1912.

With Frank Pulver apparently out of the Studebaker business, George H. Brown and Brother asked Weeber for selling rights in all of Columbia County. In a contract written on C. F. Weeber Manufacturing Works letterhead and signed by Brown and Weeber, the Brown Company agreed to "take and pay for all cars on contract for December, January, February and March" with a \$100 deposit given as each car was sold. Brown further agreed "not to handle or sell any other a than Studebaker and Patterson [sic] and you will destroy all stationary [sic] on hand and have new supply printed and in bold type make mention that you are the exclusive agent for Studebaker cars for Columbia County. We understand you have a representative in Philmont and will also in Hudson if necessary to handle properly."⁹²⁸ Brown's regular sub-dealer's agreement with Weeber and the Studebaker Corporation of American called for 24 cars (ten "35" touring cars; nine "25" touring cars; four "25" roadsters; and one "Six" touring car) as well as one delivery vehicle. All were to be shipped between December 1912 and the end of July 1913. All the cars were to be fitted with tops, windshields and Prestolite tanks. The Brown concern was to keep three Studebakers in stock.

According to the *Albany Times Union*, the "pull Weeber has at the home [Studebaker] office" resulted in his display, in spaces 42, 43 and 44 of the Albany auto show in February 1913, of a chassis "with the working parts cut out to show all the interior details of pistons, valves and gears." Weeber borrowing Studebaker for the chassis ("in great demand among Studebaker dealers") supposedly was based on the large number of cars he sold. By mid-February he already had sold ninety cars for spring delivery "through his various sub-agents, and he says that that's just a starter." He predicted the biggest year ever for the American automobile industry and Studebaker "will be way in the van when it comes to figure out the number of cars disposed of."⁹²⁹ A second story written at the time of the auto show claimed that Studebaker dealer Weeber was "always ready to explain the workings of the machine."⁹³⁰ Another newspaper said, "These [Studebaker] cars are becoming

⁹²⁸The contract is dated November 6, 1912. Weeber's own letterhead still read "Distributor of HAYNES, E-M-F '30' AND FLANDERS '20.'"

⁹²⁹February 15, 1913.

⁹³⁰*Albany Evening Journal*, February 19, 1913.

more conspicuous in this section for the reason that the buyer gets great returns from a small investment."⁹³¹

Four workshop materials for 1913 Studebakers survive in the Weeber collection at the New York State Museum: *Price List of Parts 1913 Model "AA" Thirty-five, Model "E" Right Drive Six, Price List of Parts Model "Six"* and an incomplete price list for the "Model 'SA' Studebaker '25."⁹³²

1914 Model Year

At the Washington Avenue Armory in late February and early March 1914, Christian Weeber, on the executive show committee, showed both Haynes and Studebaker cars. The Albany *Times Union*, probably parroting a press release, praised the latter make "as perhaps the greatest achievement among all those which stand to the credit of the Studebaker factories that such a car as the electrically lighted, and started, seven-passenger Studebaker 'Six' can be sold to the public completely equipped for \$1,575."⁹³³ For three days during the show, automobiles made "way to the business vehicles" when the Weeber Manufacturing Works displayed a Studebaker delivery van in the "Truck Display In Fair Japan" (Japanese decorations being the theme for the annual dealers' show).

The Studebaker line for 1914 consisted of a four-cylinder Model SC and a six-cylinder EB. Parts books for both survive in the Weeber collection at the New York State Museum.⁹³⁴ The first edition book for the EB is particularly grease-stained with fingerprints on many pages attesting to heavy use.

1915 Model Year

Weeber's representation of the generally unchanged Studebaker line continued through the

1915 model year.⁹³⁵ At the Albany auto show in February, in addition to Haynes cars, the C. F. Weeber Manufacturing Works displayed a six-cylinder Studebaker touring car; a four-cylinder touring; a four-cylinder roadster; a delivery truck; a six-cylinder chassis; and "the Studebaker full floating, Timkin bearing rear axle." The last two items likely were on loan from the Studebaker Brothers company. A display ad in *The Argus* advised readers that the Studebaker "Car Luxurious" could be seen "in the simple and conservative elegance of its appearance" at spaces 42, 43 and 44 at the auto show.⁹³⁶

Surviving 1915 model Studebaker parts books used by the Weeber Manufacturing Works include a first edition *Price List of Parts Model SD Four* with prices effective November 1, 1914.⁹³⁷ There also are two parts books for the Model EC Six, one of which apparently is unused and retains a postcard designed to have a new owner register his car with the Studebaker Company in Detroit. The other, fingerprint-stained EC parts list is incomplete.⁹³⁸ A fourth parts book for 1915 Studebakers combines EC with EB parts, i.e., those for the 1914 six-cylinder cars.⁹³⁹ This last book is incomplete, lacking the covers that would indicate date of publication or price effectiveness.

Organized in 1899, when the business was horse-drawn vehicles, the Studebaker Brothers Company of New York was dissolved by the parent company at the end of 1915.⁹⁴⁰ Automobile production at South Bend, however, continued for another half-century. Whether it was the change in distribution system that in 1915 precipitated Weeber's dropping the Studebaker line or whether the decision was Studebaker's remains to be determined. In any case, for the 1916 model year, in addition to Haynes, Christian Weeber was selling

⁹³¹*The Argus*, February 16, 1913.

⁹³²H-1933.6.339, H-1933.6.220, H-1933.6.319 and H-1933.6.287. The cover on the second is marked, "This price list is effective on and after November 23d, 1915", i.e., it was printed two years after the 1913 model year. The third "Price List. . . Effective on and after July 1st, 1913," is marked by hand in ink, "1913 R.H. Drive 6."

⁹³³March 7, 1914.

⁹³⁴There are two copies of the parts book for SC: H-1933.6.216 and 217. The first is stamped with the name and address of the C. F. Weeber Manufacturing Works ("Automobiles and Supplies"). The EB book is H-1933.6.286.

⁹³⁵The Studebakers for 1915 were the Model SD four-cylinder and the EC six.

⁹³⁶February 14, 1915. A similar but not identical display advertisement appeared in the *Albany Evening Journal*, February 17, 1915.

⁹³⁷H-1933.6.288.

⁹³⁸H-1933.6.218 and 219 respectively.

⁹³⁹H-1933.6.280.

⁹⁴⁰"Studebaker Brothers Company of New York Certificate of Dissolution by Consent of Stockholders" in corporations office of New York Secretary of State.



Figure 11.2: Photograph of Christian Weeber in a 1915 Studebaker automobile fitted with his Traction Rings invention and an improvised snow plow. He plowed the snowbound avenue in front of his house to demonstrate his new traction rings and the power of the Studebaker car. NYSM Collection, H-2000.39.79.

Allen and Standard cars instead of Studebaker. Studebaker sales in Albany, however, continued in the hands of the Albany Garage Company (also dealing in Ford, Hupmobile and Peerless cars).

While Weeber may no longer have been selling Studebakers, he likely continued to repair them. The Weeber collection at the New York State Museum includes several well used parts price lists for 1916 and 1917 Studebaker cars. These include a first edition list for the SF four-cylinder car. The front cover is marked in ink, perhaps in Christian Weeber's hand, "Office Copy 1916-Four." This list was effective August 21, 1915, a date perhaps when the Weeber Works was still considered a Studebaker agency. Two other well-used SF price lists are second edition copies with May 24, 1916, effective prices. One copy of these books is marked in ink "OFFICE."⁹⁴¹

There are two different prices lists for the 1916 Model ED six-cylinder cars. The first edition booklet has a Weeber Manufacturing Works stamp on the cover. It lacks the title page with date of effectiveness for the prices. The other price list lacks several pages, including the covers, but the title page is present giving a price effectiveness date of October 16, 1915. There are significant price differences in the two books, those in the latter often being lower.⁹⁴² In fact, a third publication, *Studebaker Revised Prices of Repair Parts for the Studebaker Models of 1914, 1915, 1916*,⁹⁴³ with an effective date of May 15, 1916, has prices similar to those announced for October 16, 1915. In effect, many Studebaker price were lowered in 1915.

The most recent Studebaker parts price list in the Weeber collection covers 1916 and 1917 cars, both four-cylinder and six-cylinder chassis in Series 16, 17 and 18.⁹⁴⁴ Lacking covers, with many torn pages and much grease staining, this booklet, pierced with a string for hanging it as a handy reference, suggests a continued busy Studebaker repair business into 1917, one assumes, for the Weeber Manufacturing Works.

⁹⁴¹H-1933.6.214. The other copy, without the "office" marking, is H-1933.6.215.

⁹⁴²H-1933.6.284 and H-1933.6.283 respectively.

⁹⁴³There is a complete revised list as well as an incomplete copy in the Weeber collection, H-1933.6.278 and H-1933.6.279 respectively.

⁹⁴⁴H-1933.6. 285.

CHAPTER 12. AGENT FOR THE ALLEN MOTOR COMPANY OF FOSTORIA, OHIO

In early 1916, Weeber advertised that his company had “selected the Allen Car to fill the gap in our line for a popular priced four-cylinder car and are satisfied we have the car that will make good.” In February 1916, the Weeber had the \$795 Allen touring car at the Albany auto show, even as he sought agents “in Unoccupied Territory.”⁹⁴⁵

For the 1917 automobile show at the Washington Avenue Armory, the C. F. Weeber Manufacturing Works displayed Allen as well as Haynes and Standard cars. The four-cylinder \$850 Allen, combined with the Haynes and Standard lines, gave “Mr. Weeber...one of the most complete lines of any Albany distributor” according to *The Argus*.⁹⁴⁶ A small February 23, 1917, *Argus* display advertisement, in conjunction with the auto show, touted the “New...sensible handsome” car with “unique finishes.”

A photograph of the exhibit (in Chapter Ten of this book) has an Allen cloverleaf roadster prominent in the image. While on February 22, 1917, *The Argus* reported, “freight congestion has interfered with the delivery of the Allen cars which Mr. Weeber intended to exhibit,” the next day a load of Allen cars “which had been on the road for some time, arrived...[in the] afternoon, making his [Weeber’s] exhibit complete” and left “C. F. Weeber...very happy last night.”⁹⁴⁷ The Allen cars on display were “much talked about,”⁹⁴⁸ including the Allen Classic four-passenger roadster but a year later, for the 1918 show, Weeber’s exhibit had only Haynes and Standard on display.

While Allen production continued into 1922, production figures remained modest. Totals for the years in which the Weeber Manufacturing Works sold Allen cars are 1,180 for 1916, 1,723 for 1917 and 1,922 for 1918, when the price for the five-

passenger touring car rose to \$1,095⁹⁴⁹. What percentage Weeber accounted for Allen sales has not been determined here.

An extant Allen parts price list from October 1917 for most Allens built to that point was received by the State Museum from the Weeber property on Central Avenue. The publication date suggests that the Weeber-Allen sales arrangement endured through the 1917 model year and perhaps into 1918. In fact, a pencil notation on the cover reads “1918.” A moderate amount of grease staining on the booklet testifies to its use. The only pencil notations in the book are the correction of two radiator hose prices for the 38 and 40 models. A second price list in the Weeber collection apparently only covers the 1917 models.⁹⁵⁰ By the 1920 model year, the Allen agency in Albany was the Albany Garage Company.⁹⁵¹

⁹⁴⁵ Albany *Times Union*, February 15, 1916; Albany *Evening Journal*, February 16, 1916.

⁹⁴⁶ February 22, 1917.

⁹⁴⁷ *The Argus*, February 24, 1917.

⁹⁴⁸ Albany *Evening Journal*, February 24, 1917.

⁹⁴⁹ Kimes et al., pp. 26-27.

⁹⁵⁰ The second price list lacks its covers. Illustrations show the sedan and coupe with their 1917 prices. The text notes the list covers the 37 and Classic models. The first list is imprinted, “Parts Price List for Allen Cars Including Model 33...34...35...38...40... The Allen Motor Co Fostoria, Ohio Second Edition Published October 1917”. H-1933.6.245 and H-1933.6.201A.

⁹⁵¹ *The Argus*, March 22, 1920, has a description of the Allen car and a display advertisement from the Albany Garage Company, both items coincide with the annual local auto show. The Albany *Evening Journal* for February 21, 1920, reported that the Garage Company “has taken over the agency for the Allen car and is showing several models in the exhibit at the automobile show in the armory.”

CHAPTER 13. AGENT FOR THE STANDARD STEEL CAR COMPANY OF PITTSBURGH, PENNSYLVANIA (FACTORY AT BUTLER)

1916 Model Year

For 1916, with the Studebaker gone from his salesroom, Christian Weeber offered the \$800 Allen car (comparable to the four-cylinder Studebaker he had sold the year before) as well as the \$1,735, eight-cylinder Standard. Built by the Standard Steel [railroad] Car Company since 1915, the Standard eight was to have a companion, \$1,000, six-cylinder car “later in the season,” according to an Albany *Times Union* report.

Christian Weeber probably secured the Standard dealership in January 1916, only a few weeks before the annual Albany auto show, at which three different Standards were to be displayed. Several weeks earlier, and “before taking on the Standard agency,” Weeber visited the Butler, Pennsylvania, Standard plant, a factory with a reported investment of “hundreds of millions of dollars, where all materials are manufactured.”

The output of the plant in alloy steels is from seven to eleven thousand tons per day. Mr. Weeber states he never saw anything like it before, and he has visited many of the largest auto manufacturers in this country. None of which control their source of raw materials.⁹⁵²

As a Standard dealer, Weeber advertised that he was looking for “[sub-] Agents in Rensselaer, Schenectady, Greene and Columbia Counties.” Interestingly, the display advertisement in the *Times Union* is marked “C. F. Weeber” rather than “C. F. Weeber Manufacturing Works.”⁹⁵³ At the auto show, two rather than three Standards were on display, a roadster and a touring car. A Standard representative also was on hand, “laying great

⁹⁵²February 15, 1916.

⁹⁵³February 15, 1916. Both the Haynes and Allen advertisements in the newspaper also identify the dealer as “C. F. Weeber.” A February 19, 1916, *Times Union* advertisement for the Weeber Traction Rings, on the other hand, is marked “C. F. Weeber Mfg. Works.”

stress on the durability of the car.” Studebaker cars, meanwhile, were being shown by the Albany Garage Company, where the “car that is attracting the most attention in the Garage company’s big exhibit is the Studebaker.”

So many visitors to the show have been attracted by this car that the Garage Company has been forced to call in many of its sub-agents in order properly to take care of the buyers.⁹⁵⁴

1917 Model Year

A 1917 Standard was the first car visitors saw at the 1917 Albany auto show. For the new Standard, Weeber claimed:

...remarkably attractive lines and finish of this car on par with its performance. With its magneto equipped eight cylinder motor, delivering over 80 horse power, the driver experiences a feeling of power almost unbelievable.⁹⁵⁵

A large C. F. Weeber Manufacturing Works display advertisement (“For 1917—The First ‘8’ with a Magneto”) in *The Argus* on February 24, 1917, urged readers to “See this car in spaces 42-43-44 at the Armory to-night before the Big Auto Show Closes.” The auto show Standard, painted beige and fitted with Spanish leather upholstery, attracted “so much attention” and was sold on February 23 to F. O. Carnos [sic] of Albany.⁹⁵⁶ On

⁹⁵⁴*Albany Evening Journal*, February 16, 1916.

⁹⁵⁵Quoted in the *Albany Evening Journal*, February 22, 1917. *The Argus*, February 22, 1917, also noted that the Standard Eight was “the first car which greets the visitor’s eye when entering the automobile show.”

⁹⁵⁶*The Argus*, February 24, 1917. A different display advertisement appeared in the *Albany Evening Journal* for February 17, 1917, noting, “We Will Exhibit at Auto Show in State Armory, Albany, Feb. 17th to 24th.” “Carnos” likely was Frank O.



Figure 13.1: Photograph of Albany Automobile dealers luncheon, 1916. Christian Weeber at a “well known Country Inn near Albany,” Marion Weeber noted, “Chris is at top right and had removed his derby, no doubt by request. His hair is still curled-up from wearing it. He usually combed his hair down flat.” NYSM Collection, H-1984.2.2.

February 22 and 23, other large display ads followed the first. A Weeber notice of the auto show display at the Armory was appended to Standard text claiming that “Words Fail” (February 22) and “Neither brush nor pen can picture stamina, strength and power” of the car (February 23). The *Albany Evening Journal* said the Standard was “one of the big features of the show.”⁹⁵⁷

1918 Model Year

The Weeber Manufacturing Works continued to sell both Standard and Haynes cars in the 1918 model year. The six- and twelve-cylinder Haynes models meshed with the eight-cylinder Standards in prices and number of engine cylinders. In late

Carnes, an agent for the New England Cotton Yarn Company. Carnes, at 25 Manning Boulevard, lived near Christian Weeber. See the 1916 Albany city directory. Standard prices for 1917 were \$1,950 for a four-passenger roadster; \$2,000 for a seven-passenger touring car; \$2,500 for a “Springfield sedan;” and \$3,500 for a limousine. The author does not know which model Carnes purchased but assumes it was a touring car.

⁹⁵⁷February 24, 1917.

February, Weeber advertised four Standard models with “Power and Grandeur,” ranging in cost from \$2,450 for either a seven-passenger touring car or a roadster to \$4,000 for a limousine. The sedan cost \$3,500. The Haynes cars, on the other hand, ranged from \$1,725 for a six-cylinder touring car to \$2,785 for a twelve-cylinder touring. The six-cylinder sedan cost \$2,585. (Haynes car prices were advanced \$125 on March 1, 1918.) All the cars sold by the Weeber Company also had freight and war tax added to their delivered prices.⁹⁵⁸

1919 Model Year

The C. F. Weeber Manufacturing Works offered the Standard Eight again during 1919. At the time of the annual Albany auto show in February, a Weeber display advertisement listed Standards from \$2,750 for a seven-passenger touring car to \$4,300 for a limousine. Interestingly, at this point, Weeber’s two car lines—Standard and Haynes—offered no potentially high volume, four-cylinder

⁹⁵⁸*The Argus*, February 17, 1918.

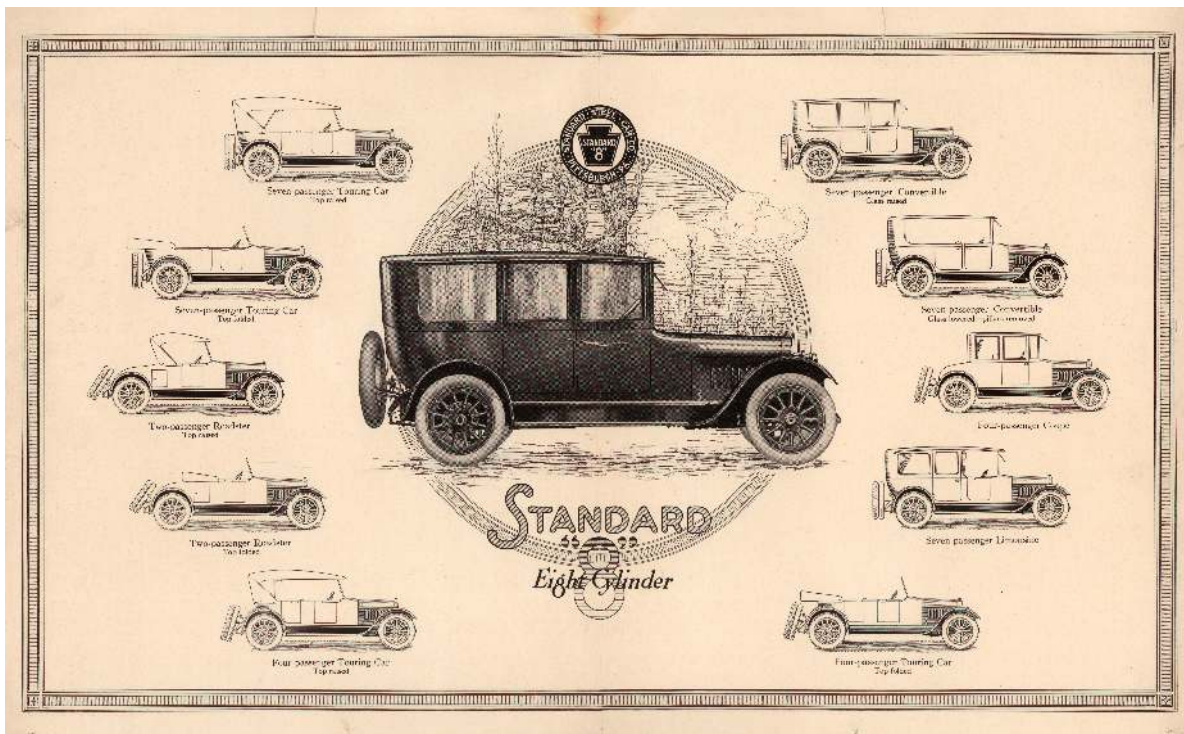

Figure 13.2: Standard automobiles brochure, 1918. The cover panel has been stamped with the C. F. Weeber Manufacturing Works name and address. The rear panel has specifications for the Standard Eight Model G. NYSM Collection, H-1984.2.2.

cars, only sixes, eights and twelves. The Haynes cars were slightly cheaper than the Standards in six-cylinder format and slightly more expensive in twelve-cylinder versions, e.g., seven-passenger Haynes touring cars were \$2,485 and \$3,250 according to engine type. Perhaps it was this redundancy of the parallel Haynes and Standard lines that prompted Weeber to drop the latter for 1920.

Still in May 1919, the Weeber Manufacturing Works was offered “for immediate delivery” any of three Standard touring cars by the Taylor Motors Corporation at 1920 Broadway in New York City. A concluding note suggests that the Taylor firm was a distributing agency for Standard autos, perhaps Weeber’s normal source of cars for resale. “At this writing we can make delivery on four passengers two weeks from date of receipt of your order.”⁹⁵⁹

A booklet titled, *Hotel Woodward...New York Presents a Directory Automobile Row,* in the Weeber

collection at the New York State Museum, probably dates from 1918. It lists the Taylor Motor Corporation at Broadway and 64th Street as distributors of the Standard cars. G. Herbert Taylor was president of the Taylor firm; Edward H. Rodgers, manager and treasurer; H. C. Whitney, sales manager; and A. H. Atwood, wholesale manager. If the Weeber Manufacturing Works, indeed, routinely secured their Standard cars from the Taylor Corporation, then it’s likely these were the men with whom Christian Weeber and his associates dealt.

⁹⁵⁹E. C. Johnson [illegible?] to C. F. Weeber Mfg. Wks., May 2, 1919. The writer’s signature is difficult to read. While the title under the signature reads, “Vice Pres. & Sec’y,” the letterhead indicates that two other individuals had held those positions not long before.

Albany Automobile Show



AUTOMOBILES WILL HAVE A BIG YEAR, DECLARES HUGO

Secretary Predicts Registration in New York State for 1919 Will Total 550,000 Cars

MORE MONEY IN CIRCULATION

Francis M. Hugo, Secretary of the New York State Motor Vehicle Association, declared today that the automobile industry in this state will have a big year in 1919. He predicted that the registration of motor vehicles in this state for 1919 will total 550,000 cars, a record for the state.



Francis M. Hugo

Francis M. Hugo, secretary of the New York State Motor Vehicle Association, declared today that the automobile industry in this state will have a big year in 1919. He predicted that the registration of motor vehicles in this state for 1919 will total 550,000 cars, a record for the state.

Mr. Hugo said that the increase in the number of automobiles in this state is due to the fact that the automobile is becoming more popular than ever before. He said that the automobile is now being used for business as well as for pleasure.

He also said that the automobile industry is now becoming more important than ever before. He said that the automobile is now being used for business as well as for pleasure.

PROMISING FUTURE FOR INTERNATIONAL BRANCH

A. J. McNeish, general manager of the International Branch of the Albany Automobile Show, declared today that the future of the international branch of the show is very promising.

Mr. McNeish said that the international branch of the show is now becoming more important than ever before. He said that the international branch of the show is now being used for business as well as for pleasure.

HIGHWAY ACCIDENTS NOT WHOLLY DUE TO MOTORISTS

Unreasonable Automobile Legislation the Result of Passion, Prejudice and Ignorance of Facts

WHAT THE STATISTICS SHOW

Christian Weeber, fifth from right in the drawing above, is the author of the article. He is a prominent automobile dealer and has written extensively on automobile-related topics.



Christian Weeber

Christian Weeber, fifth from right in the drawing above, is the author of the article. He is a prominent automobile dealer and has written extensively on automobile-related topics.

Mr. Weeber said that the statistics show that highway accidents are not wholly due to motorists. He said that many accidents are caused by unreasonable automobile legislation.

He said that the statistics show that many accidents are caused by unreasonable automobile legislation. He said that the statistics show that many accidents are caused by unreasonable automobile legislation.

Christian Weeber, fifth from right in the drawing above, is the author of the article. He is a prominent automobile dealer and has written extensively on automobile-related topics.

Mr. Weeber said that the statistics show that highway accidents are not wholly due to motorists. He said that many accidents are caused by unreasonable automobile legislation.

He said that the statistics show that many accidents are caused by unreasonable automobile legislation. He said that the statistics show that many accidents are caused by unreasonable automobile legislation.

Christian Weeber, fifth from right in the drawing above, is the author of the article. He is a prominent automobile dealer and has written extensively on automobile-related topics.

Mr. Weeber said that the statistics show that highway accidents are not wholly due to motorists. He said that many accidents are caused by unreasonable automobile legislation.

He said that the statistics show that many accidents are caused by unreasonable automobile legislation. He said that the statistics show that many accidents are caused by unreasonable automobile legislation.

Christian Weeber, fifth from right in the drawing above, is the author of the article. He is a prominent automobile dealer and has written extensively on automobile-related topics.

Mr. Weeber said that the statistics show that highway accidents are not wholly due to motorists. He said that many accidents are caused by unreasonable automobile legislation.

He said that the statistics show that many accidents are caused by unreasonable automobile legislation. He said that the statistics show that many accidents are caused by unreasonable automobile legislation.

NEGLECT OF HOUSING PLANS BY U. S. SHAMEFUL, SAYS KOHN

Responsible Governmental Authorities, U. S. 32-Negative of housing for the future is a shameful neglect, declared U. S. Representative Charles C. Kohn today.

Mr. Kohn said that the neglect of housing plans by the U. S. is a shameful neglect. He said that the neglect of housing plans by the U. S. is a shameful neglect.

Responsible Governmental Authorities, U. S. 32-Negative of housing for the future is a shameful neglect, declared U. S. Representative Charles C. Kohn today.

Mr. Kohn said that the neglect of housing plans by the U. S. is a shameful neglect. He said that the neglect of housing plans by the U. S. is a shameful neglect.

Responsible Governmental Authorities, U. S. 32-Negative of housing for the future is a shameful neglect, declared U. S. Representative Charles C. Kohn today.

Mr. Kohn said that the neglect of housing plans by the U. S. is a shameful neglect. He said that the neglect of housing plans by the U. S. is a shameful neglect.

Responsible Governmental Authorities, U. S. 32-Negative of housing for the future is a shameful neglect, declared U. S. Representative Charles C. Kohn today.

Mr. Kohn said that the neglect of housing plans by the U. S. is a shameful neglect. He said that the neglect of housing plans by the U. S. is a shameful neglect.

Responsible Governmental Authorities, U. S. 32-Negative of housing for the future is a shameful neglect, declared U. S. Representative Charles C. Kohn today.

Mr. Kohn said that the neglect of housing plans by the U. S. is a shameful neglect. He said that the neglect of housing plans by the U. S. is a shameful neglect.

Responsible Governmental Authorities, U. S. 32-Negative of housing for the future is a shameful neglect, declared U. S. Representative Charles C. Kohn today.

Mr. Kohn said that the neglect of housing plans by the U. S. is a shameful neglect. He said that the neglect of housing plans by the U. S. is a shameful neglect.

GERMAN PROFESSOR REVIEWS RUN'S SHORTCOMINGS

German Professor Reviews Run's Shortcomings

The German professor reviewed the shortcomings of the run. He said that the run has many shortcomings. He said that the run has many shortcomings.

Figure 13.3: Albany Evening Journal, February 15, 1919. Drawing of Christian Weeber (fifth from right) with other Albany automobile dealers depicted by cartoonist at the time of the annual car show in the Washington Avenue Armory. Courtesy of the New York State Library, Manuscript and Special Collections.

CHAPTER 14. AGENT FOR VARIOUS TRUCK MANUFACTURERS: CHASE MOTOR TRUCK COMPANY OF SYRACUSE, NEW YORK

In early 1909, Christian Weeber was agent for the light, air-cooled, two-stroke trucks manufactured by the Chase Motor Truck Company of Syracuse.⁹⁶⁰ Chase sales manager W. H. Durphy, responding to a communication from the Weeber Manufacturing Works, noted that he was pleased to hear that Weeber was “pushing the sale of the CHASE MOTOR WAGONS vigorously and that you have a number of prospects lined up to whom you will make demonstrations in the near future.” A three-cylinder model had been introduced recently, “so more powerful on hills, that we wish you could arrange to take one of these.” Delivery on the new truck was two weeks, while the less powerful two-cylinder wagons were available in three or four days.⁹⁶¹

Durphy’s colleague, A. M. Clehan, also wrote to Weeber praising the larger truck. Quoting the Chase agents in Washington, D.C., H. C. Wilson & Bro., Clehan noted that:

Six barrels of four, weight 140 lbs. apiece, and four good men including the driver started up Capitol Hill on high speed and maintained the same speed all the way up, the engine running as smoothly as could be all the time... The car then proceeded to a very muddy street on which, a few days previously, some of our taxicabs had been stuck all night, and plowed through with the same load on without any trouble whatever... we can go through any mud providing it is not more than 18 inches deep.⁹⁶²

⁹⁶⁰*The Horseless Age*, October 3, 1906, announced the organization of the Chase Motor Truck Company, a partnership to build trucks, delivery wagons and combination vehicles—“a light wagon for tools and materials... which can be quickly turned into a pleasure car.” One of the partners, Aurin M. Chase, had been associated with the H. H. Franklin Manufacturing Company, a Syracuse builder of autos with air-cooled engines.

⁹⁶¹W. H. Durphy to C. F. Weeber Manufacturing Company, March 23, 1909.

⁹⁶²*Ibid.*

The utilization of hard rubber tires on high wheels similar to those fitted to carriages and horse-drawn wagons likely contributed to the Chase’s utility on unimproved roadways. Clehan confirmed this idea by noting that “in the matter of performance and capacity for bad roads and conditions, there is nothing on the market that can touch our three cylinder wagon, and we would advise our agents to push this model... Can we not have an order from you for a three cylinder car either with a democrat body or full panel top? We feel certain you would sell it in a very few days after receiving it.” Whether Weeber agreed or not is unclear but two weeks later he requested an electrotype of the two-cylinder wagon. Durphy said he was pleased Weeber was “going to do some advertising and we sincerely hope that you can send us an order with a few days. If you are making demonstrations, we should like to know what success you are having.”⁹⁶³ In fact, a Weeber Manufacturing Works display advertisement for Chase Motor Wagons appeared in the March 28 and April 4, 1909, issues of the *Albany Argus*. The newspaper noted, “The garage has ready for delivery a number of motor trucks of from 500 pounds to five tons.”⁹⁶⁴

One prospect, Durphy suggested, was “Mr. Baker, President of the Albany Iron & Hardware Co.,” a friend of Chase business manager E. A. Kingsbury. A demonstration “will do no harm and may lead to a sale for you, particularly if you mention that we have just sold the two most prominent hardware concerns in this city [Syracuse].”⁹⁶⁵ Weeber indicated in pencil on Durphy’s letter on May 3 that he was taking action although his precise words are illegible. Kingsbury himself wrote to Weeber on May 19, acknowledging a

⁹⁶³Durphy to Weeber Manufacturing Works, April 8, 1909.

⁹⁶⁴April 4, 1909.

⁹⁶⁵Durphy to Weeber Manufacturing Works, April 26, 1909.

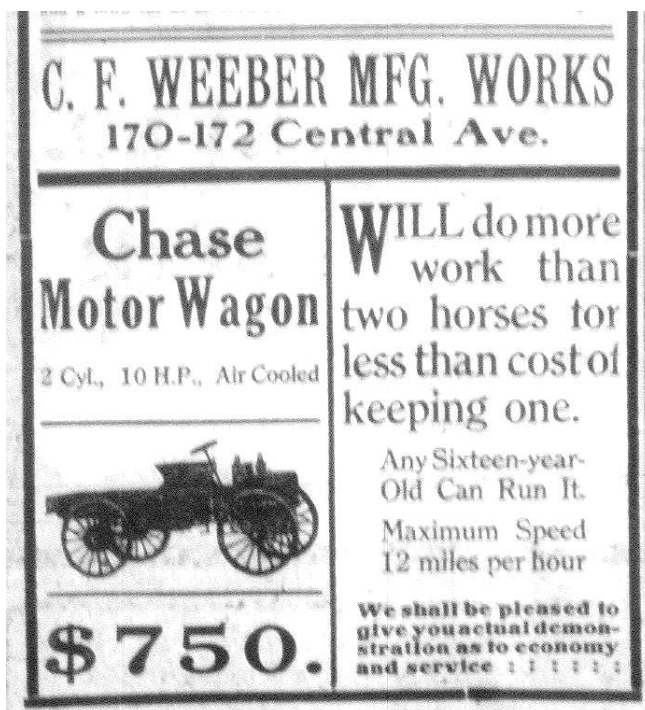

Figure 14.1: *The Argus*, April 4, 1909. Christian Weeber advertised Chase trucks in the early spring of 1909. Courtesy of the New York State Library, Manuscripts and Special Collections.

“valued communication of May 18th.” Kingsbury thought Albany was ripe for Chase sales and “with your ability, that it will only be a question of time ‘ere you have made a goodly start.”⁹⁶⁶

Weeber also advertised the Chase in several Albany newspapers in combination with promotions of the Weeber Manufacturing Works as a Ford agency. For example, the *Sunday Press* for March 14 and March 28, 1909, ran a display advertisement the upper two-thirds of which were dedicated to the Model T Ford and the bottom third to the “Chase Motor Wagon.” At \$750 for the two-cylinder, ten-horsepower, air-cooled version, the Chase would “do more work than two horses for less than cost of keeping one. Any Sixteen-year Old Can Run It. Maximum Speed 12 miles per hour. We shall be pleased to give you actual demonstration as to economy and service.” A small cut of the Chase accompanied the text.

Apparently Weeber’s sales territory included Troy, for on May 22, 1909, Durphy wrote that the Hudson River Motor Vehicle Company of Troy had

⁹⁶⁶E. A. Kingsbury to Weeber Manufacturing Works, May 19, 1909.

asked for “catalogue and discounts.” Chase had mailed a catalogue and “advised that they could probably make satisfactory arrangements with you [Weeber] if they had a prospective order in sight.” Weeber noted “write” on the letter along with the date “5/26.” In June, Kingsbury let Weeber know that William S. Nicholls in Hoosick Falls had inquired about the Chase truck and had been advised that “you [Weeber] are looking after our interests in that territory.” Weeber noted that he “wrote to both 6/18.”

As far as catalogues are concerned, late in May the Chase Company promised to send twenty-five of a new edition and asked if Weeber might want some of the “blue card,” a flyer with an image and specifications for the two-cylinder truck. The fact that only twenty-five catalogues would satisfy a distributor for the Chase truck suggests the limited market the manufacturer saw for their product in the Albany area.

Durphy wrote to Weeber in June that he had heard that the Albany branch of the Milburn Wagon Company was “interested in a light delivery wagon, and would like to negotiate for an agency.” Weeber made a note to “call” and “phone.” Later he penciled that, “They say that they are not interested in any Motor Wagon & have no idea of selling any.” On the other hand, Josiah Young, at 375 River Street in Troy, wrote the factory asking for a catalogue and “full information.” Weeber noted that he or a colleague should “write today as I would like to sell truck.”

In September 1909, Durphy wrote to the Weeber firm that the new Model F Surrey was proving to be a popular item with the factory having “shipped seven of them this week, and it will help you to put in a demonstrator.” A few weeks later, Chase wrote to ask if there might be a market for a wagon “a little heavier than our Standard Model D,” perhaps with a carrying capacity of 1,500 pounds. With the larger engine (4 $\frac{1}{8}$ ” bore x 4” stroke), it would sell for \$1,250 with an express truck body. Weeber noted, “write” and “10.” By February 1910, such a truck was available with a rated capacity of 1,500 pounds “of course subject to the usual overload of 50%.”⁹⁶⁷ The 10-foot express body listed for \$1,250. The “full panel top” version cost \$1,450.

⁹⁶⁷W. M. Chase to Weeber Manufacturing Works, February 10, 1910.

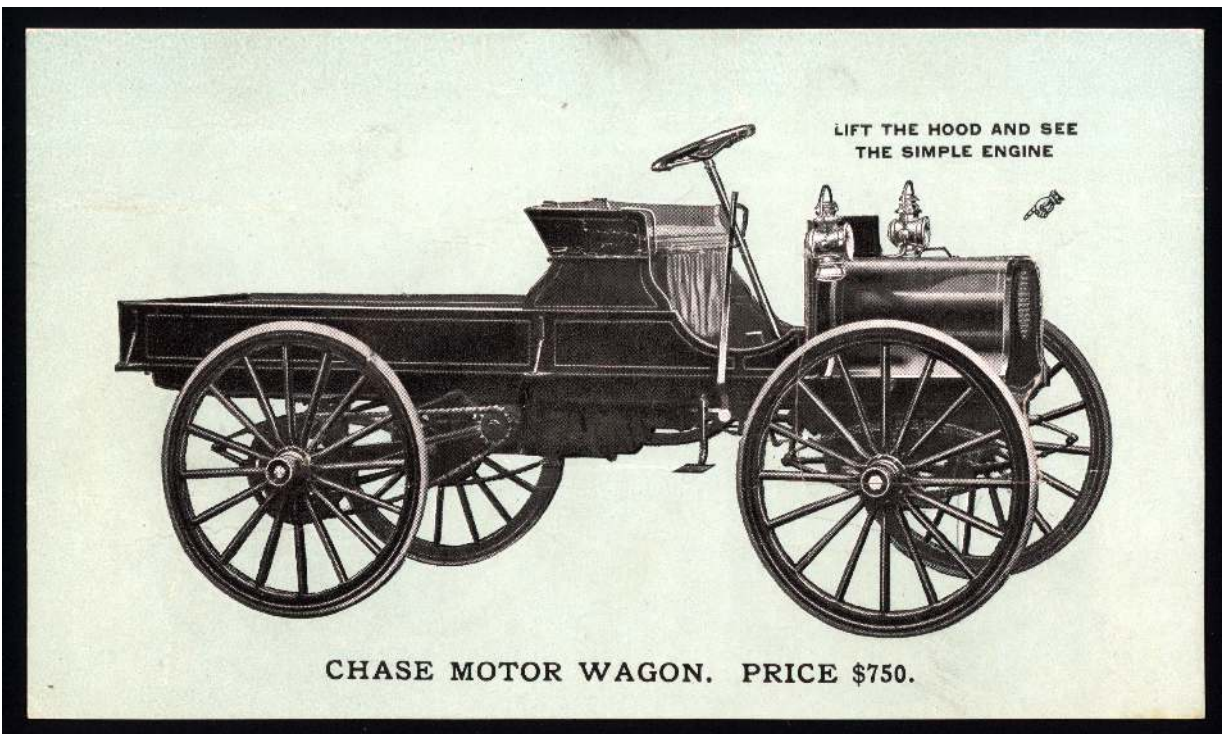

Figure 14.2: Advertising card, c. 1909, for the light Chase truck. Lifting the flap on the card where the engine hood is shown reveals an engraved image of the two-cylinder, air-cooled, two-stroke power plant. This card is pinned to a May 28, 1909, letter from E. A. Kingsbury to the Weeber Manufacturing Works. NYSM Collection, H-2000.39.NN.

Meanwhile, a lighter, Model D Chase, rated at a half-ton load capacity, in Kansas City apparently bested the performance of several other trucks in a reliability run. “The high wheels were able to get through the road obstructions with the minimum account of power, although the load carried [1,350 pounds] was excessive.”⁹⁶⁸

In October 1909, the *Times Union* reported that the Weeber Manufacturing Works were agents for the Chase truck (as well as Ford and Ohio cars).⁹⁶⁹ In February 1910, a new Chase sales manager, A. G. Durston,⁹⁷⁰ communicated with the Weeber Manufacturing Works. In early March 1910, he wrote again to note that the factory had fifteen 1909 models C and D Chase trucks left over. The vehicles were “taking up valuable space in our factory” and so were being offered at a 30% discount from the selling prices. The only difference between

the 1909 and 1910 models, Durston wrote, was the plain bearings in the former.⁹⁷¹

As noted above, in a list of used vehicles, probably dating from early 1910, Weeber included a 1909 Chase truck “Model O,” most likely a transcription error for a Model C. Pencil notations give the value of the truck at \$500-\$550. On April 26, 1910, Weeber wrote to L. (Louis) W. Killeen, a tobacconist in Schenectady, to ask if “you are still interested in a Motor Wagon, if so can quote you an interesting figure.” Killeen answered on the same sheet. “What Have You to offer.” Weeber noted, “an [answer] 5/2 Copy \$500.” Of course, one does not know specifically what vehicle was being promoted but the \$500 figure suggests that Weeber was offering Killeen the Chase truck on the used vehicle list.

In September 1910, Weeber telegraphed the Chase Company asking for the address of their New York City agent. Kingsbury replied by mail with the address of the Motor Mark on Broadway. The last surviving letter to Weeber from the Chase Company is a letter from Kingsbury on October

⁹⁶⁸Chase to Weeber Manufacturing Works, form letter, February 4, 1910.

⁹⁶⁹October 4, 1909.

⁹⁷⁰In 1910, Durston held 100 Chase shares. See “Certificate to Increase the Number of Directors of the Chase Motor Truck Company” in the corporations unit of the New York Secretary of State.

⁹⁷¹Durston to Weeber Manufacturing Works, March 2, 1910.

17, 1910, noting that he was aware of “one or two complaints of our representatives borrowing money from agencies.” But, he continued, “all of our traveling men are always supplied with their salary check promptly and satisfactory funds for traveling expenses and there is no reason why they cannot procure money from this Company if it is needed.”⁹⁷²

Perhaps Weeber’s sales of American trucks, at least as early as 1909, figured in his giving up Chase distribution, although the American vehicles generally were heavier than the Chase wagons. The Chase Company built trucks until about 1917 and was dissolved in 1921.⁹⁷³

American Motor Truck Company of Lockport, New York

In 1909, the C. F. Weeber Manufacturing Works represented the American Motor Truck Company in distribution of American trucks. The American company, organized at the end of 1905, was a subsidiary of the American District Steam Company of Lockport, manufacturers of “heating and power systems,” according to the 1909 Lockport city directory. American District Steam owned over 50% of American Motor Truck stock. In addition, many of the directors and officers of the two companies were the same individuals.⁹⁷⁴

In November 1906, *The Horseless Age* described a 1907 line of three- and five-ton American trucks “as previously.”⁹⁷⁵ A new American Motor Truck factory was in Caledonia, where production likely began in early 1907. Early March 1906, *The Horse-*

less Age already had published drawings of the truck along with a comprehensive description. Notable were 2½-inch drag bars supplementing rear hub brakes and a planetary transmission. “Believing that the sliding gear transmission in the hands of untrained men is liable to serious derangement, due to unskilled handling,” the American company had “designed an improved form of planetary gear, which is of exceptional size and strength.”⁹⁷⁶ Given his experience with the planetary transmissions in the Ford cars, perhaps Christian Weeber thought the American use of that system advantageous, as well.

At the end of 1906, American displayed a 3-ton stake body truck at the annual—and important—Chicago auto show.⁹⁷⁷ It will be remembered that Christian Weeber had been at the Chicago show the previous year to promote his automobile specialties. It is possible that he went again in 1907 and there encountered American Motor Truck Company officials but the author has no evidence of such a trip.

In any event, in the summer of 1909 American Motor Truck vice-president and general manager Elmer B. Olmsted⁹⁷⁸ responded to a Weeber query about a 1½-2 ton chassis, for which Weeber had a prospect. With a wood panel top extending over the driver’s seat, the cost to the buyer would have been \$3,250. Olmsted noted that the American factory was “turning out lots of these Model M cars, and they are doing fine work.”⁹⁷⁹

At the end of the summer, Olmsted again wrote in response to a query from Weeber. This time a potential customer was interested in a “hard tired

⁹⁷²Kingsbury to Weeber Manufacturing Works, October 17, 1910.

⁹⁷³James T. Lenzke, editor, *Standard Catalog of American Light-Duty Trucks* (Iola, Wisconsin, 2001).

⁹⁷⁴In August 1908, American District Steam owned 260 shares of American Motor Truck. Eleven individuals owned a combined total of 230 shares. See certificate of “Unanimous Consent of Stockholders to Increase of Number of Directors” in the Corporations office of the New York Secretary of State. As illustration of the joint employment responsibilities, in 1909 Charles R. Bishop was secretary and general manager of the District Steam Company and president of the truck company; Robert Hall was treasurer of the steam company and secretary of the truck company; Henry J. Babcock was constructing engineer of the steam company and treasurer of the truck company. See Lockport city directories as well as the American Motor Truck Company letterhead.

⁹⁷⁵Vol. 18, no. 20, November 14, 1906.

⁹⁷⁶*The Horseless Age*. Vol. 19, no. 4, January 23, 1907, reported, “Their new plant is nearing completion, and the company expect to begin business by the 1st of February.” Officers at that point were Carl [sic] R. Bishop, president; H. C. Eddy, vice-president; Robert Hall, secretary; H. J. Babcock, treasurer; and J. A. White, secretary [sic] and general manager. *The Horseless Age*, January 24, 1906, reported that the incorporators of the American Motor Truck Company of Albany [sic] were Bishop, Henry J. Babcock, Robert Hall, Bert W. Hall and Henry C. Eddy. The description of the American truck is in the March 7, 1906, vol. 17, no. 10 issue.

⁹⁷⁷The two-speed, four-cylinder, 40-horsepower, chain-drive truck ran on solid rubber tires and had a top speed of twelve miles per hour. See *The Horseless Age*, December 4, 1907, vol. 20, no. 23.

⁹⁷⁸Olmsted in 1908 had been secretary of the Auto-Car Equipment Company of Kenmore. See Buffalo city directory.

⁹⁷⁹Olmsted to C. F. Weeber Manufacturing Works, July 27, 1909.

stage built on the order of our sightseeing car to carry 25 passengers and to have at least a 45 H.P. engine." Olmsted referred Weeber to the American catalogue, which included a 24-passenger car with lamps, roll up curtains and a swivel electric search-light giving 80 hr. service from 6 volt 60 ampere storage battery" for \$4,250. A 29-passenger rig would cost \$4,500. A 30-passenger "special model 300 with low hung construction" was \$5,000, subject to "our extreme discount of 20%." Olmsted said several vehicles similar to the last were in use in San Juan, Puerto Rico. Olmsted ended his letter by asking what had "become of your prospect for model M 1½ ton chassis on which we quoted you price July 27th?"⁹⁸⁰ Weeber noted that he would "write... called 9/4."

In March 1910, Olmsted wrote again. This time in response to a Weeber query about a three-ton truck with a sliding gear transmission; standard equipment on the 3.5-ton Model L and 5-ton Model O trucks was American's "own planetary with multiple disc clutch." There was, however, an option of a three-speed, selective shift transmission for the Model L, and American was prepared to build a sliding gear transmission for the O at a cost of \$250 for a customer in Wisconsin "willing to pay extra price to get it." Olmsted thought the planetary gear "far better for this work... The Bagley & Sewall Company of Watertown, N.Y. have used one of these in their five-ton truck for three years with perfect satisfaction...."

Olmsted wrote that the manufacturer was prepared to "allow you our extreme agency discount of 20%." Quick delivery was possible, since regular shipping for the season did not begin until the middle of April "and we have run our factory night and day all winter to get stock ahead." Weeber penciled on Olmsted's letter that he "wrote to Troy 3/2 and sent card," apparently in response to a query there, perhaps to the potential buyer interested in the sliding gear transmission. Weeber also recorded that he "wrote for more catalogues 3/28."⁹⁸¹

The beginning and ending dates for the period in which the Weeber concern sold American trucks has not been determined here. The last entry

⁹⁸⁰Olmsted to C. F. Weeber Mfg. Works, September 2, 1909. It should be remembered that Weeber supplied a customer with a sightseeing vehicle constructed on a used Thomas automobile chassis the month prior.

⁹⁸¹Olmsted to Weeber Mfg. Works, March 23, 1910.

for the American Motor Truck Company is in the 1910 Lockport directory. It is likely production ended during that year leaving Weeber without a source of medium and heavy trucks until he secured a Mais agency. By the summer of 1911, as the American Motor Truck Company was dissolved, it was owned wholly by L. E. Ewing of Cleveland, Ohio.⁹⁸² The District Steam Company survived the end of the truck enterprise.

Mais Motor Truck Company of Indianapolis, Indiana

By 1911, the C. F. Weeber Manufacturing Company was an agency for the shaft-driven, medium to heavy duty vehicles manufactured by the Mais Motor Truck Company of Indianapolis.

The business relationship continued at least to mid-1912, when Christian Weeber and W. T. Baes [illegible?], of the Mais sales department, corresponded about replacing a defective wheel on a truck owned by A. J. Cunningham of Greenville. The truck's serial number, 125, suggests limited production for Mais vehicles. Other Mais trucks handled by Weeber had suffered problems with a steering wheel, gears, toe board, dead axle and radiator.⁹⁸³

In November 1911, the Weeber Company, apparently in response to a customer's interest in a truck purchase, received a telegram followed by a letter from C. H. Warwick, Mais general sales manager, quoting a price of \$2,950 for a 1.5 ton chassis truck with a 160-inch wheelbase.⁹⁸⁴ A follow-up letter from Warwick mentioned that longer wheelbase frames with a length up to fifteen feet "back of the driver's seat" were possible "where light commodities are to be hauled."⁹⁸⁵ The author has not determined whether Weeber subsequently ordered and sold such a truck.

⁹⁸²Ewing as American president owned 756 of 760 outstanding shares. See "Proceedings for the Voluntary Dissolution of American Motor Truck Company" in corporation unit of New York Secretary of State.

⁹⁸³Various letters from Mais Motor Truck Company personnel to the C. F. Weeber Mfg. Works, September 13, 1911; November 6, 1911; March 12, 1912; June 12, 1912; and June 18, 1912.

⁹⁸⁴C. H. Warwick to C. F. Weeber Mfg. Works, November 10, 1911.

⁹⁸⁵Warwick to C. F. Weeber Mfg. Works, November 10, 1911.



Figure 14.3: Photograph of the 30-passenger American Motor Truck Company stage. E. B. Olmsted, general manager of the company, said the photo was taken in front of the Caledonia factory when the car “was out testing before it was finally finished. I spent a Sunday afternoon with a party making a long country trip. We did a [sic] 102 miles in six hours running time over all kinds of roads.” NYSM Collection, H-1933.6.NN.

Another telegram from the Mais Motor Truck Company to the “C. F. Weeber Mfg. Co.” informed Weeber that Mais could not fit four-inch tires on their truck but could supply “three and one half inch diamond which we believe [sic] will give better service than your own tires Wire answer.”⁹⁸⁶

In November 1911, Mais advertising manager Paul P. Willis wrote to the Weeber Works enclosing a page from the *Brewers’ Journal*, a full page advertisement for Mais trucks. The Weeber concern was listed as one of twelve “distributors in principal cities.” Willis suggested “an ad that you might utilize also if you care to have a follow-up system among the brewers in your territory.”⁹⁸⁷

In February 1912, Will H. Brown, president and general manager of the Mais firm, wrote to the

⁹⁸⁶The Western Union Day Letter, signed “Mais Motor Truck Co.,” is dated November 20 without a year designation.

⁹⁸⁷Willis to Weeber Mfg. Works, November 10, 1911. The other Mais distributors were in New York City, Boston, Toledo, Pittsburgh, St. Louis, Los Angeles, Detroit, Philadelphia, Chicago, Cleveland and San Francisco. The enclosure survives with the Willis letter in the Weeber collection at the New York State Museum.

Weeber Manufacturing Company that conditions were:

...improving daily at the factory, and we refinements on the car as fast as developments show where anything needed. With the reorganization of the Company, we are in better shape to serve our agents.

Want to assure you of the heartiest cooperation from this end of the line, and hope that the handling of the Mais truck will prove a successful venture for you.⁹⁸⁸

At the end of May 1912, Brown’s secretary, A. E. Funkhouse, wrote to the Weeber firm that “Mr. Alanson A. Aird, of Watervliet, N.Y., is in the market for a commercial truck.” The Mais Company sent Aird “some literature pertaining to the Mais—advising him that you would be glad to give him a demonstration.” Weeber marked the Funkhouse letter “Phoned 6/18/12 will think over about drive & again.”

In July 1912, the Mais firm was in receivership⁹⁸⁹ and it is likely Weeber’s business relationship with

⁹⁸⁸February 20, 1912.

⁹⁸⁹*The Carriage Monthly*, vol. 50, no. 1, April 1914.

CHAS. R. BISHOP, President.

E. B. OLMSTED, Vice Pres. & Gen'l Mgr.

ROBERT HALL, Secy.

H. J. BABCOCK, Treas.



CABLE ADDRESS, "AMERTRUCK"
CODES—WESTERN UNION & A.B.C. 5th Edition.

Lockport, N. Y. July 27, 1909

C. F. Weeber Mfg. Works,
170 Central Ave.,
Albany, N. Y.

Gentlemen:-

Referring to yours of the 16th and your prospect for one of our model M 1 1/2 to 2 ton chassis, with wood panel top extending over the driver's seat would cost approximately \$3250.00. We have just completed and delivered a truck with the upper half of rear panel of screen wire, and the lower half tail gate, so that if the load is a long one or bulky freight may be loaded out on the tail gate, or it can be closed up and locked securely.

We shall be pleased to hear from you on this prospect, and hope you will land it.

We are turning out lots of these model M cars, and they are doing fine work.

Yours very truly,

Vice Pres. & Gen'l Manager.

EBO/E

Figure 14.4: American Motor Truck Company letterhead, 1909-1910. NYSM Collection, H-1933-6.NN.

Mais ended at that point. In 1913, a reorganized Mais Motor Truck Company had a completely different group of officers in charge of the Mais factory, Brown having been replaced by Frank H. Wheeler.⁹⁹⁰

By February 1913, Mais trucks were being sold in Albany by the Boulevard Garage Company at State and Lark Streets.⁹⁹¹ In April 1914, *The Carriage Monthly* said the Mais, “one of the best known motor trucks in the United States,” had begun truck deliveries in February 1911. Three years later “some 350 of them are distributed over the United States, all of which [trucks] are said to be in active use.” Whether this low number of vehicles, as opposed to or combined with the Mais bankruptcy, was a factor in Christian Weeber’s separation from the Mais line perhaps is a matter for speculation. The Mais Company reportedly survived to 1916, when the concern was acquired by the Premier Motor Manufacturing Company, also of Indianapolis.⁹⁹²

Other Motor Trucks Considered for Weeber Agency Status

Auto-Car

In the later winter and early spring of 1908, perhaps after receiving queries from potential customers asking about motor trucks, Christian Weeber contacted various manufacturers.

The Auto-Car Equipment Company truck, built in Buffalo, was one possibility Weeber considered. In reply to a Weeber letter, Auto-Car treasurer G. [George] W. Atterbury responded that:

⁹⁹⁰Wheeler had been in the carburetor manufacturing business as Wheeler and Schebler. In 1913, Brown was president and general manager of the Brown Commercial Car Company, automobile manufacturer in Peru, Indiana, with offices in Indianapolis. See the Indianapolis city directories for 1911-1913.

⁹⁹¹Advertisement in the *Albany Evening Journal*, February 19, 1913. The Boulevard Garage also sold Winton and Marmon automobiles. At the 1914 Albany Automobile Show, Boulevard Garage displayed a Mais 3-ton truck. See Albany Automobile Dealers’ Association, *Albany Automobile Show* (program), pp. 38, 79. In 1914, The Boulevard Company also exhibited Marmon and Jeffery automobiles.

⁹⁹²James T. Lenzke, editor, *Standard Catalog of American Light-Duty Trucks* (Iola, Wisconsin, 2001), p. 874. A 1911 starting date is given for the Mais Company.

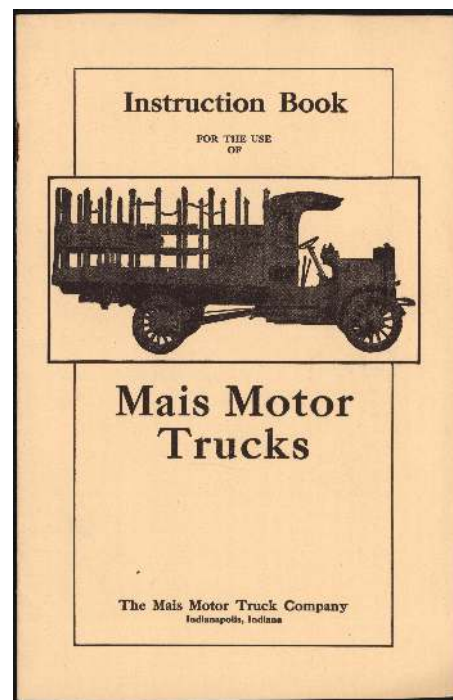

Figure 14.5: Mais instruction booklet cover. NYHSM Collection, H-1933.6.NN.

Your favor of March 12th received and carefully noted. I am glad you like the appearance of our truck for it is certainly the most up to date vehicle in its class ever put out.

I am sure the gasoline car would take any of the regular grades you have in Albany under full load, in fact you can depend on this machine taking any grades ordinarily traversed by teams.⁹⁹³

Mack

Mack was another make considered. Eastern sales manager H. P. Chestnut for the Mack Brothers Motor Car Company in Allentown, Pennsylvania, stated:

The writer did not have a chance to stop off at your city as he had expected returning from

⁹⁹³Atterbury to C. F. Weeber Mfg. Wks., March 14, 1908. The Weeber collection at the New York State Museum contains an extensive catalogue of the Autocar Company of Ardmore, Pennsylvania. This 64 page booklet, *The Autocar for Business Expansion Catalogue Series No. 6* Published May 1914, shows many motor trucks in use by a variety of different agencies. It’s doubtful that there was any connection between the Auto-Car Equipment Company and the Autocar Company. Whether Christian Weeber had any dealings with the Autocar firm is unknown here. The New York State Museum catalogue number for the Autocar catalogue is H-1933.6.200.



Figure 14.6: Photograph of a Mais truck with Weeber sign, c. 1912. NYSM Collection, H-1933.6.158.

Buffalo. Trust you will in the meantime follow up your friends whom you reported considering the purchase of motor trucks. We will likely have a chance of visiting you 10 or 15 days later. In the meantime will hope to hear from you.⁹⁹⁴

Rapid

A third firm contacted was the Rapid Motor Vehicle Company of Pontiac, Michigan. Three letters in response, one with reference to a fourth, survive in the Weeber collection at the State Museum. In one letter, Rapid sales manager W. Myers [illegible?] wrote that Rapid was sending the Weeber Works “a beautiful hanger portraying the largest line of commercial gasoline cars manufactured by any concern in the world.” In another letter, J. R. Bell of the sales department acknowledges receipt of a Weeber letter telling of the arrival of the hanger and the Weeber Company’s effort “to work up some trade in the commercial line.”⁹⁹⁵

⁹⁹⁴ April 1, 1908.

⁹⁹⁵ The sales manager’s signature is difficult to read. His letter is dated March 27, 1908. Two letters signed by Bell are dated April 2 and April 9, 1908.

Reliable Dayton

A fourth manufacturer of commercial vehicles Weeber contacted was the Reliable Dayton Motor Car Company of Chicago, makers of a high wheel automobile. A Reliable letter from late March 1908 alludes to a Weeber customer’s requirement for a vehicle.

In reply to yours of the 25th, for which we thank you, we are enclosing circular of our type “F” equipped with auxiliary delivery body with catalog under separate cover.

If will you put us in touch with this party we will be able at a later date to submit them a model particularly suited to their needs.⁹⁹⁶

⁹⁹⁶ Allan Miller, sales manager, to C. F. Weeber Mfg. Co. [sic], March 27, 1908. A follow-up letter on April 7, 1908, apparently was a standard text promoting the use of reasonably priced automobiles rather than specialized trucks.

Automobile Lines Possibly Considered by Christian Weeber for Agency Representation

Tourist

A Tourist automobile catalogue for 1907 models is part of the Weeber collection at the museum. Pencil marks in the catalogue attest to someone's interest in the car's wooden frame of the smaller, K-7 model, which was a two-cylinder vehicle priced at \$1,250 in touring car form. Why the Los Angeles-built car would have appealed to Christian Weeber, if it did, would be a puzzle since the Tourist firm largely targeted on "Pacific coast buyers."⁹⁹⁷

Berkshire

On the other hand, the Pittsfield, Massachusetts-built Berkshire car, represented by a handbill in the Weeber collection, was a 1907 model more appropriate for sale in the Albany area. The brochure claimed, "Berkshire cars are made to negotiate Berkshire Hills, and a car that does this will do good work anywhere."⁹⁹⁸

Dragon

Two photographs received in the 1930s with the Weeber collection at the New York State Museum show Dragon automobiles. One Dragon is a running chassis with two men sitting on it and the other a five-passenger touring car. The first print is stamped with the name of a Detroit photography business, the Manning Studio. The other has the stamp of a New York City photography firm, Ayer and Wells at 1881 Broadway.⁹⁹⁹ The man behind the steering wheel in both pictures may be the same individual.

⁹⁹⁷*Tourist Automobiles Maid* [sic] in *Los Angeles, Cal.* (no date but the autos depicted were built for the 1907 model year. H-1933.6.224).

⁹⁹⁸The Berkshire was a four-cylinder, chain-drive, \$3,500 machine fitted with a wooden touring car body for five to seven people. The Berkshire Automobile Company "Advance Sheet" is H-1933.6.225 in the Weeber Collection at the New York State Museum. Kimes et al., claim about 150 Berkshires were built from the 1905 to and including the 1912 model years.

⁹⁹⁹The rubber stamp impression is incomplete, lacking the first letters of the initial word. The cars are identified by the word "Dragon" on the hubcaps.

Kimes and Clark note the Dragon Automobile Company of Detroit built its first cars in 1906. Production moved to Philadelphia but the company failed by the end of 1907. While the \$2,000 car supposedly benefited from fine engineering, assembly quality was poor. Both a roadster and a touring car were advertised.¹⁰⁰⁰ Perhaps Christian Weeber investigated selling Dragons, which were shown at the December 1906 auto show at the Grand Central Palace in Manhattan. At that time, his joint venture with Willard Sutherland had agencies for Ford and Maxwell cars. Both the Maxwell and the Ford lines offered cars much cheaper and much more expensive than the Dragons, which in terms of price would have complemented the other two makes.

Schacht

An April 1908 letter from the Schacht Manufacturing Company of Cincinnati promoted that company's high wheel style automobile, "the simplest, most practical, efficient and economical car built today." The Schacht concern was "quite desirous that you take the agency for our Invincible auto runabout in your city and vicinity."¹⁰⁰¹

Various Trade Names

In 1909, the C. F. Weeber Manufacturing Works received several written inquiries seeking agents for automobiles. In February, the Arthrop Motor Car Company of New York City, distributors for the Wisconsin-built Kissel Kar, mailed a form letter to the "Weeber Mfg. Works" looking for "representation in your city." With prices from \$1,350 to \$3,000, the thirty- to sixty-horsepower Kissel Kars were supposedly "the greatest value for the money of any line on the market."¹⁰⁰² Weeber's simple penciled oval on the letter suggests he had little further interest.

Another offer came from H. R. Averill, sales manager for the Fal Motor Company of Chicago, who in May 1909 sought a dealer for the Fal-Car automobile, "which affords a number of attractive

¹⁰⁰⁰Kimes, p. 492.

¹⁰⁰¹Walter J. Ilg [illegible?] stamped signature, Schacht treasurer, to Weeber Mfg. Works, April 17, 1908.

¹⁰⁰²Arthrop Motor Car Company to Weeber Mfg. Works, February 15, 1909.

features at a reasonable price." In spite of the opportunity to "secure unhampered territory," Weeber put the letter aside with only his pencil oval to record his reading of the message.¹⁰⁰³

On the other hand, he noted that he "wrote 7/28" in response to a July 24 letter from the Nordyke & Marmon Company, Inc., in Indianapolis, makers of the Marmon car. This time the query had been addressed to the "Webber Automobile Works," offering an "opportunity for reaching and holding the better class of trade... We want first class representation in your city and are ready now to talk business for 1910."¹⁰⁰⁴ What response Weeber received to his reply has not been documented here.

By early 1910, perhaps dismayed by a troubled relationship with the Ford Motor Company, Christian Weeber had taken the initiative in looking for new lines of automobiles to sell. In March, he received a reply to a query addressed to the Car Makers Selling Company of Chicago, "sales managers" for the makers of Anhut and DeTamble cars and Weyher delivery vehicles. Car Makers representative L. P. Zinke wrote to Weeber that "your territory is still open" for the two auto lines. Weeber was requested to tell "as to the approximate amount of territory you would be able to cover, together with the number of cars you could handle."¹⁰⁰⁵ The Michigan-built Anhut was a short-lived six-cylinder car not sold after the 1910 season. The Indiana-built DeTamble was a less expensive two-cylinder or four-cylinder vehicle built by a financially troubled company that produced cars until 1913.¹⁰⁰⁶

Apparently, Weeber also initiated correspondence with the H. H. Babcock Company of Watertown, which had introduced a Model 30, thirty-five horsepower touring car to supplement the buggy wheel style cars with which they began production the year before. Deliveries of the Model 30 were to begin about May 1, 1910. There was still "some territory that is free and we shall be pleased

¹⁰⁰³H. R. Averill to Webber [sic] Automobile [sic] Works, May 8, 1909. The Fal-Car also is known as the F.A.L.

¹⁰⁰⁴Nordyke & Marmon Company, Inc., to Webber Automobile Works, July 24, 1909.

¹⁰⁰⁵Zinke to C. F. Weeber Mfg. Works, March 24, 1910.

¹⁰⁰⁶Kimes, *op. cit.*, pp. 53, 413.

to hear from you promptly should you desire to investigate the car and apply for agency."¹⁰⁰⁷

Still another firm responding to a query from Weeber was the Monitor Automobile Works of Chicago, manufacturers of two-cylinder, high wheel vehicles intended principally for light delivery work but sometimes equipped for transporting passengers. Sales manager F. W. Stewart wrote with an offer to "arrange with you to handle Monitors in your territory."¹⁰⁰⁸

Other automotive lines Weeber contemplated in the 1909-1910 period include the products of the Henderson Motor Sales Company of Indianapolis (\$1,000 Henderson and, as "general sales agents" for the Cole Motor Car Company, \$1,500 Cole);¹⁰⁰⁹ the Moon Motor Car Company of St. Louis (\$1,500-\$3,000 Moon);¹⁰¹⁰ the Henry Motor Car Company of Muskegon, Michigan (\$1,750 Henry 35);¹⁰¹¹ the National Motor Vehicle Company of Indianapolis (\$2,500 National);¹⁰¹² the Auto-Bug Company of Norwalk, Ohio (Norwalk delivery vehicle);¹⁰¹³ and the Westcott Motor Car Company of Richmond, Indiana ("What could you do with a Peerless or Packard completely equipped so that you could sell for \$2,000.00? You could get rid of a few couldn't you?").¹⁰¹⁴

A February 1910, somewhat vague letter is in the Weeber collection at the State Museum. On the letterhead of C. Arthur Benjamin, Inc., an automobile dealership in Syracuse, the writer, Alvie G. Williams, acknowledges a letter from the Weeber Manufacturing Works and "appreciates your

¹⁰⁰⁷H. H. Babcock Company to C. F. Webber [sic] Automobile [sic] Works, March 25, 1910.

¹⁰⁰⁸Stewart to C. F. Weeber Mfg. Works, February 1, 1910.

¹⁰⁰⁹Charles P. Henderson, vice-president and manager, Henderson Motor Sales Company to Webber [sic] Auto. [sic] Wks., August 5, 1909. While the Cole car existed, the Henderson did not, and according to Kimes, *op. cit.*, p. 695, would not materialize until 1912. In 1910, Charles Henderson was associated with the Westcott Motor Car Company.

¹⁰¹⁰C. A. Duerr, Moon Motor Car Company of New York, to C. F. Webber [sic] Automobile [sic] Wks, August 5, 1909.

¹⁰¹¹David H. Henry, Henry Motor Car Company, to Webber [sic] Automobile [sic] Works, May 7, 1910.

¹⁰¹²J. M. Clarke, National Motor Vehicle Company, to C. F. Weeber [sic] Mfg. Co. [sic], January 20, 1910.

¹⁰¹³Charles Glaser, The Auto-Bug Company, to C. F. Webber [sic] Automobile [sic] Works, March 25, 1910.

¹⁰¹⁴Charles P. Henderson, Westcott Motor Car Company sales department, Indianapolis, to C. F. Weeber Mfg. Works, May 3, 1910. The signature, rubber stamped, is identical to that affixed to a Henderson Motor Sales Company solicitation letter dated August 5, 1909.

releasing the two counties to us, and we will do all we can to assist you in any way possible." What counties these were and, indeed, what was being released is not specified. While the letterhead shows that the Benjamin firm dealt in Packard, Elmore and E-M-F cars, at that point the Weeber concern, to the best of the present writer's knowledge, was a Ford and Haynes dealership. To be sure E-M-F cars replaced Fords in the Weeber line but that was a year later. In case one is tempted to suggest the typist wrote "1910" when "1911" was intended. By the summer of 1911, Williams, who had been secretary of the Benjamin firm, was in business for himself selling Warren automobiles and supplies on South Salina Street.¹⁰¹⁵

Perhaps Christian Weeber had relinquished some of the "northern [perhaps westernmost of the northern] counties" for which he was seeking Haynes agents in April 1910.¹⁰¹⁶ Another possibility might be territory for the Chase truck, although it's likely the Chase Company itself would have overseen distribution in the home city. Or perhaps it was the American truck, for which Weeber was approaching the end of his agency.

¹⁰¹⁵The Syracuse directory for 1911 apparently was distributed in the summer of that year. The 1909 directory, the first year the Benjamin Company is listed, shows Williams as secretary. *The Horseless Age*, April 11, 1900, vol. 6, no. 2, reported that C. Arthur Benjamin's Syracuse Automobile Company was "special agent" for the Locomobile Company of American having the "exclusive agency" for fourteen counties in central and northern New York (Onondaga, Herkimer, Chenango, Cayuga, Jefferson, St. Lawrence, Franklin, Broome, Lewis, Oswego, Cortland, Madison, Oneida and Tompkins). Formerly "interested in the bicycle trade," Benjamin was appointing "sub-agents in the various counties."

¹⁰¹⁶In 1910, Weeber sought sub-agents in seven counties (Columbia, Greene, Schoharie, Rensselaer, Schenectady, Saratoga, Washington) near Albany as well as in the unidentified "northern counties." See a display advertisement in *The Argus*, April 10, 1910.

CHAPTER 15. C. F. WEEBER MANUFACTURING WORKS AFTER DISCONTINUANCE OF NEW AUTOMOBILE SALES

Albany Storage Battery Company

A letter to the C. F. Weeber Manufacturing Works from the Franklin Automobile Company, a Syracuse manufacturer, might suggest that as early as September 1909, Christian Weeber contemplated leaving the retail automobile trade. Or it may indicate merely that he owned property, or planned to, which he could sell to a party interested in establishing an automobile business in Albany. Unfortunately, Weeber's initiating letter to the Franklin Company does not survive in the museum's Weeber collection. Nor is there any indication in the Franklin letter that he intended to respond to that message. The text of the Franklin letter follows:

Your letter of September 22 received.

In reference to a site for the Branch which we are to open in Albany, we are not interested in buying a place. However, we might be interested in leasing a place for a period of three years with an option of five years more.

If this would appeal to you, we would be glad to have a proposition from you.¹⁰¹⁷

That Weeber in the 1909-1910 period wished to sell out is, however, indicated also by a letter to him from A. H. Hughes in Elbridge. Hughes letterhead indicates he was a purveyor of "general merchandise." His letter from January 1910 states:

Yours of the 22nd at hand in reply would say that I have been away or would have answered your letter before. Please give us an outline of your business also what it would

¹⁰¹⁷T.[Thomas] R. Lippard, Franklin assistant general manager, to C. F. Weeber Mfg. Works, September 23, 1909. Lippard is listed in the 1909 Syracuse city directory as a secretary. There is no entry for the Franklin Automobile Company in the 1909 Albany city directory. By the summer of 1910, when the directory for that year was issued, the Franklin Automobile Company was in business at 87 Spring Street. The next year the operation had moved to 242 Washington Avenue.

require in cash to take it over. We are going into the business.¹⁰¹⁸

Clipped to the Hughes letter is a piece of Keeler's Hotel stationery. On it someone has written in ink, "A. H. Hughes Elbridge N.Y." Perhaps someone else added in pencil, "Wagham." [illegible?] Weeber has marked in pencil, "wrote 1/22 No Copy." Might this second document suggest a meeting at Keeler's Hotel in Albany where Weeber mentioned that he was thinking of selling his business and a listener suggested Weeber contact Hughes, who was known to be thinking of buying such an establishment?¹⁰¹⁹ Interestingly, both Hughes and the Franklin Company were located in Onondaga County, giving thought to someone familiar with the auto business there telling Weeber about the opportunities to dispose of his enterprise to parties in central New York. In any case, it was a decade before Weeber gave up the retail automobile business.

In February 1920, Christian Weeber exhibited cars for the last time at the annual Albany car show. Long associated with the show management, Weeber remained on the program committee and also remained an exhibitor in the 1920s. No longer occupying three spaces in the middle of the Armory floor, he now utilized smaller areas primarily to display batteries and automotive accessories.

Marion Weeber recalled the 1924 auto show. "I was in our booth with dad all week, on the main floor of the N.Y. State Armory at the Albany Automobile Show. I was 19. We no longer sold cars, but were demonstrating current Weeber patented inventions, such as our Tire Chains with rings that gripped and Traction Rings with paddles that

¹⁰¹⁸Hughes' letter is dated January 27, 1910.

¹⁰¹⁹The Hughes name and address apparently were written by someone other than Weeber, although the present author cannot be positive. Whether the Wagham name was recorded by Weeber is uncertain, in the author's mind.

clamped on the wheels.”¹⁰²⁰ A contract for the 1925 Albany automobile show was with the C. F. Weeber Mfg. Works, which paid \$80 for ten feet of space and \$20 for a “1 Page Advertisement, Official Program.” A sketch of the exhibit area in the February 1926 show depicts Christian Weeber standing beside a car in his booth, which displayed automobile accessories. His cartoon figure claims, “I built the First Car in Albany.”¹⁰²¹ Weeber was back at the show the next year, again with accessories.



As early as 1915, batteries apparently had been an important part of Weeber’s auto show exhibit. A duplicate contract from the 1916 show, dated December 29, 1915, lists the exhibitor as the Albany Storage Battery Company, Inc.¹⁰²² In 1917, as the C. F. Weeber Manufacturing Works displayed Haynes, Standard and Allen cars, “In another part of the drill shed Mr. Weeber has more space in which the Marco battery is on display. This battery is considered one of the best on the market and is used exclusively by the New York City police department.”¹⁰²³

For 1919, a list of Albany auto show exhibitors notes Weeber’s display of “Haynes, Standard [autos] and Vesta storage batteries.”¹⁰²⁴ *The Argus* said at the show Christian Weeber “was as busy as a man catching snakes... explaining the Vesta storage batteries. He is just at the door, and when someone buys a car they naturally look around for appendages for the machine. Enter Mr. Weeber.”¹⁰²⁵

Surviving Vesta materials in the Weeber collection at the New York State Museum include a June 1, 1917, catalogue with parts both for starting batteries as well as for lighting and ignition units. The prices listed likely are retail charges for a comprehensive list of parts—plates, plate groups, separators, pillar straps, cell connectors, cables, termi-

nals, clamps, sockets, nuts, screws, covers, jars, boxes, handles, hold downs, acid, lead, sealing compound and paint. The cover page is stamped “Albany Storage Battery Co., Inc.,¹⁰²⁶ 168 Central Avenue, Albany. N.Y.” The same page is marked by hand in pencil, “Old.” There is also a Vesta battery catalogue from July 1, 1917, “Bulletin No. 101-C.” It has laid in both consumer and dealer net price lists.

Two different Vesta price lists from February 26, 1918, remain in the Weeber collection. One list shows retail, dealer and “service station contract” prices. The other has retail, dealer and “distributors’ contract” prices, the last being, item for item, less than the service station costs. For example, battery type 75, a six-volt unit, was \$28.73 to service stations and \$23.89 to distributors.¹⁰²⁷ Whether the Albany Storage Battery Company served as a Vesta distributor or service station (or whether Christian Weeber as a dealer merely had a copy of the distributor price sheet) is uncertain but the accumulated Vesta publications suggest service station status.

Another Vesta catalogue is marked by hand in pencil, probably by Christian Weeber, “Latest Cat. Feb. 1, 1919.” Laid inside the catalogue are several price lists from 1919, including a “Prices Schedule—Service Station Contract” from October 20, 1919.” Assuming Weeber’s battery company operated as a Vesta service station, the prices he paid remained less item for item than those charged to Vesta dealers. For example, the Vesta battery number 6L19Y listed for \$56.71 to the consumer or \$53.87 with an exchange battery.¹⁰²⁸ The dealer cost was \$45.37 and the service station price \$35.44. Altogether there were 203 different Vesta six- and twelve-volt batteries.

October 1918 and March 1919 copies of *Twelve-Eighty*, a monthly published by the Vesta Accumulator Company, for the “Promotion of Efficiency of it’s [sic] Service Stations,” further points to the Albany Storage Battery Company serving as a Vesta

¹⁰²⁰Marion Weeber to Geoffrey Stein, November 14, 1990.

¹⁰²¹*Times Union*, February 24, 1926. Weeber shared a large booth on the back (north) wall with the Albany Hardware & Iron Company.

¹⁰²²The rent for space 91, with twelve feet of frontage, was \$36. The space was along the north wall close to the west side of the building. The show ran from February 12 through February 19, 1916.

¹⁰²³*Albany Evening Journal*, February 24, 1917.

¹⁰²⁴*The Argus*, February 23, 1919.

¹⁰²⁵February 18, 1919.

¹⁰²⁶The corporations bureau of the New York Secretary of State reports there is no record of incorporation for the Albany Storage Battery Company.

¹⁰²⁷The retail and dealer prices were \$44.37 and \$33.56, respectively.

¹⁰²⁸Vesta Accumulator Company, “Vesta” catalogue (Chicago, 1919). A pencil notation on the back cover reads, “Green Franklin-1916-runs 12 volt high type used Battery.”

service station. The earlier issue, vol. two, no. 10, shows in part the effect of World War I with advice for the battery business in dealing with shortages of materials.¹⁰²⁹

A photograph, which Marion Weeber dated “about 1914” but may likelier date from about 1917, shows a wheel fitted with a Weeber Traction Ring in front the Weeber Manufacturing Works building at 170 Central Avenue. In the image, one also sees a portion of the adjacent structure at 168 Central (as previously noted, the mailing address for Albany Storage Battery). Above the entrance to the basement level a piece of a sign reads, “...RY CO. Inc.,” one assumes a portion of “Albany Storage Battery Co., Inc.” If this is the case, then it would appear that the battery business was carried on in the lowest level of what was constructed as a townhouse. Given the somewhat messy affair that was the battery business, a ground floor or basement location makes sense.

A 1920 catalogue of the Essex Storage Battery and Supply Company in the Weeber collection at the State Museum contains representations and descriptions of the equipment used by battery repair shops, such as the Albany Storage Battery Company. Included were a “high rate battery drop test” device enabling the user to demonstrate to a customer “on the spot, the real condition of his battery. It saves him time – increases confidence – brings you more repair jobs. It helps you to make immediate sale of a new battery.” The cost was \$112.50. Other equipment included motor-generator sets for charging batteries (\$98 to \$157); rectifiers for charging batteries (\$75 to \$175); repair outfits for steaming open, melting lead and sealing batteries with compound (\$38.50 to \$44); stills for purifying water (\$33 to \$412.50); oxyacetylene, other gas torches and electric devices for burning (cutting) lead (\$40 to \$53.25); rheostats (“charging panels”) for charging batteries from line current (\$28 to \$46.75); plate burning rack (\$121.50); lead burning molds (\$1.65); acid (\$.06 per pound); sealing compound (\$.15 per pound); battery paint (\$7.50 for five gallons); lead (\$.20 per pound); hydrometer (\$2.25); acid syringe (\$4.25–“It saves acid, clothes, benches and floors.”); battery plate press (\$35.50);

¹⁰²⁹The earlier issue, for October 1, 1918, has New York State Museum accession number H-1933.6.349. The later, water damaged publication, dated March 1, 1919, has most of all pages stuck together rendering the contents unreadable.

pillar post builders (\$5.50 set); connector puller (\$2.00); and acid apron (\$3.85 to \$5) among other battery repair items. The Essex catalogue included materials for maintaining other portions of automotive electrical systems (“everything related to starting, lighting and ignition for the automobile”). A “Confidential Net Price List A” is laid into the catalogue. Most of the prices are the same as those listed in the catalogue, although dealers were allowed 10% for cash on the tenth day of the month following the date of invoice and Essex paid excise taxes. The Essex line of batteries, Columbia, was discounted 33⅓% for resale.¹⁰³⁰ While the Essex equipment list is instructive in demonstrating the work and equipment in a battery shop, whether Christian Weeber dealt with Essex is unknown here.

A 1921 prices list for the Strongheart Battery Plate Manufacturing Company in Rochester is dated October 1, 1921. In addition to plates, Strongheart offered maple and oak cases, jars, covers, plate straps, terminals, separators, acid, sealing compound, burning lead, wire leads, acid proof paint and other items since the company would “render our services in getting anything which we do not carry in stock.” Battery dealers were advised that, “We do not manufacture Storage Batteries.” An undated sticker in the Weeber collection advises the reader to “Prolong Life of Your Willard Battery” by keeping the cells filled with distilled water and charging when the specific gravity of the acid fell below 1.250. Whether the Albany Storage Battery Company sold the products of the Willard Storage Battery Company of Cleveland, Ohio, is not known here. A pamphlet for Look Sparking Storage Batteries, manufactured by the Look Electric Company and distributed by the Franco-American Auto & Supply Company of Chicago, also is among Weeber artifacts at the New York State Museum. The Look piece is undated but probably is pre-1920. The text touts a battery that will “give from 1,000 to 1,500 miles per each charge after third charging.” Whether the Weeber Manufacturing Works stocked or sold any Look batteries is unknown here.

In 1922, Weeber was in space 96 for the Armory auto show. Advertising as the Albany Storage

¹⁰³⁰Essex Storage Battery and Supply Company, Incorporated, *Catalog 1920* (Newark, New Jersey), New York State Museum accession H-1933.6.211.

Battery Company, he reported that he distributed Marko and Luthy batteries “with either Wood or Hard Rubber Boxes at unheard of low prices.” He also exchanged and repaired batteries.¹⁰³¹ A Marko storage battery parts list in the Weeber collection at the museum is printed “Effective May 15, 1923” and marked by Christian Weeber in pencil, “5/21/1923,” perhaps the date he received it. A Marko (“The Mark O’ Quality”) catalogue dated April 1924 points to a continuing Weeber-Marko business relationship.

Luthy catalogues in the Weeber collection exist from 1919 through 1921. The earliest is “Catalog Number One,” printed in May 1919 and distributed by Luthy Sales Company, Inc. on Tenth Avenue in New York City. The batteries themselves were the products of the Luthy Storage Battery Company of Newark, New Jersey. “This catalogue is intended primarily for the distributors and agents of the Luthy Battery.” The first section is a listing of automobiles and their required batteries. Other sections of the booklet depict batteries in drawings, list prices, list repair parts and list batteries with the cars which the individual units fit. The 1920 booklet is “Catalog No. 2,” with a fading, mimeographed “Price List No. 4” from September 15, 1920 laid in. “Catalog No. 3,” distributed by the Luthy Battery Sales Company of Boston, Massachusetts, has a price list dated August 1, 1922 laid in.

In late 1922, Weeber received a mailing from the Cole Storage Battery Company in Chicago offering complete batteries, battery parts (with an offer to discount retroactively plates purchased in 100 plate lots once 1,000 had been ordered), and a “special offer,” namely a complete battery station outfit allegedly worth \$240 for \$175. While there is no record of Weeber having needed or purchased such an outfit, its listing suggests the equipment a battery service station required in 1922.

- 10 Battery Tungar [charger] with two bulbs
- 150 Amp. Break down set, complete with voltmeter and ammeter
- Plate burning rack
- Oxweld torch and tip
- Oxweld gauge and connections
- 18 feet of high pressure gum hose
- 10 double clips with one foot of No. 12 wire

¹⁰³¹Display advertisement in the *Albany Evening Journal*, February 16, 1922.

- Putty knife
- Compound knife
- Pair end cutters
- Hand reamer
- Positive post builder
- Negative post builder

A Cole order form noted that Cole paid the federal tax. Buyers were advised to send no money, since shipping was C.O.D. “Examine the goods thoroughly before you pay. You are under no obligation if you are not perfectly satisfied.” The reverse of the form offered “A Real Business Getter!,” namely a three color, steel, 24” x 36” sign for \$2. The dealer’s name would be placed below the standard “Service Station Cole Batteries Dealers Name Here” text. The baked enamel sign mounted on a wooden frame supposedly could be “easily read more than a block away.”¹⁰³²

A September 1926 “Confidential Dealers’ Price List” for automotive electrical parts and supplies distributed by the Standard Motor Products Company of Long Island City, attests to a continuing Albany Storage Battery Company or C.F. Weeber Manufacturing Works trade in such items as coils, battery cables, switches, lamp sockets, lamps and other miscellaneous parts. Standard also sold battery chargers, which were discounted 25% for one to three units; 33⅓% for four or more. The price list apparently accompanied “Catalog Number Twenty-Seven,” which displayed “Automotive Electrical Parts and Specialties for All Cars.” Parts are listed for models from 1916 through 1926.¹⁰³³

In the early 1920s, batteries, rather than line current, often powered radio receivers. Low voltage “A” and higher voltage “B” batteries were needed. Both dry cell and rechargeable storage batteries were used. Morgan E. McMahon has observed that the storage batteries were expensive and messy, emitting fumes and leaking acid. Radio batteries also required frequent recharge. “Battery charging

¹⁰³²The Cole mailing included a “Confidential Dealers’ Net Prices” effective October 20, 1922.

¹⁰³³The two chargers listed at \$14 and \$20 each. Dealer discounts on other items averaged more than 50%. The price list, as other Standard Motor items, was the gift of Pauline P. Weeber. In addition to the price list and catalog twenty-five, there is a water damaged “Standard Parts for Standard Cars Catalog Number Twenty Five” (H-1933.6.265). Perhaps the last dates from 1925, but due to pages adhering to each other, there is no access to the title page. (Catalog twenty-seven is H-1933.6.199.)

stations would pick up a battery and charge it for \$1.00, or would provide rental batteries for 25c a day."¹⁰³⁴ With the introduction of alternating current powered radios in 1927, the radio battery business was done.

Whether the Albany Storage Battery Company was active in the radio battery business has not been determined here. One would think selling and servicing such batteries would have been likely, given that selling and servicing automobile batteries was such a similar occupation. One piece of evidence that Christian Weeber, at a minimum, considered the radio battery business is a letter and accompanying handbill touting the Marko Storage B Battery.

In a cover letter dated June 25, 1924, the Marko Storage Battery Company of Brooklyn announced 24- and 48-volt "B" batteries "with special patented cover arrangement that absolutely prevents acid seepage, which is prevalent in rechargeable "B" Batteries." Both Marko batteries were rated at 4.5 ampere hours. The 24 volt unit listed at \$9.95 and was offered to Weeber at \$5.95. The 48 volt battery listed at \$19.95 and was available to Weeber at \$11.55. Shipment of the first was immediate; that of the second "in about one week."¹⁰³⁵ As has been noted above, Weeber had been a dealer in Marko batteries at least since 1922.

C. F. Weeber Manufacturing Works in the 1920s

While the Albany Storage Battery Company was located at 168 Central Avenue, in the 1920s that address also was that of the C. F. Weeber Manufacturing Works. In 1920, Christian Weeber vacated the first floor of the building at 170-172 Central Avenue, renting the premises to the Kelly-Springfield Tire Company.¹⁰³⁶ The tire operation would occupy the Weeber-owned structure to the end of the decade. Although the Albany city directories show the Kelly-Springfield operation extant during the

summer of 1928, the building was vacant by mid-1931 with Kelly-Springfield no longer in business.

With no show room available, it's not likely that Christian Weeber sold many automobiles in the 1920s. If he had maintained use of the rear portion of his buildings fronting at 170 and 172 Central Avenue, then repair and storage of a number of automobiles would have been possible using Bradford Street for access. Marion Weeber later recalled that the Kelly-Springfield concern occupied the structure from front to back ("rented the main floor through"). If 168 Central Avenue was not crowded enough, in the 1930 period Marion Weeber also had a business presence. The 1931-1932 city directory lists 168 as the location of the "Greeting Carde Studio" and the working address of Marion G. Weeber as an artist. The Greeting Carde Studio was further identified as "greeting card engravers."

Although no longer an automobile dealer in the 1920s, Christian Weeber remained a member of the Empire State Automobile Merchants Association, Inc. at least through 1928. He was also a member of the Albany Chamber of Commerce and the Albany Auto Club.¹⁰³⁷

¹⁰³⁴Morgan A. McMahon, *Vintage Radio* (Palos Verdes Peninsula, California: Vintage Radio, 1981, third edition), p. 214.

¹⁰³⁵Marko Storage Battery Company to Albany Storage Battery Company, June 25, 1924. The letterhead notes that Paul M. Marko was proprietor of the Brooklyn-based firm.

¹⁰³⁶The Kelly-Springfield Company previously had been located at 238 Washington Avenue. See the Albany city directories for 1918 and 1919.

¹⁰³⁷Membership cards for the years 1926, 1927 and 1926-1927 (August 15, 1927) were found in "Card Case Vest Pocket Christian F. Weeber, Sept. 28 1932," according to a note made by Marion Weeber in 1996. These cards are now part of the New York State Museum's Weeber collection, H-1996-31.2-4.

CHAPTER 16. POST-1910 INVENTIONS AND PRODUCTS DEVELOPMENT, MANUFACTURE AND DISTRIBUTION

In early 1912, the Albany *Knickerbocker Press* noted that the Weeber Manufacturing Works “is one of the pioneer institutions in the city and makes most everything for automobiles. Mr. Weeber is one of the leaders in his profession and has many inventions under consideration that he will shortly put upon the market.”

Interestingly, the article continued with a description of the F. W. Battershall Company’s “thermo gasket.” Ironically, and likely coincidentally to the apparently unpatented Battershall invention, one of Christian Weeber’s major projects from the late 1910s to the end of his life was perfecting a fuel transforming system to improve performance and economy in automobile engines. What success Fletcher Battershall had with his thermo gasket is unknown here. The words used to name his device suggest pre-heating of the fuel-air mixture, a system that Weeber utilized as well.

The *Thomas Register of American Manufacturers* for 1914 listed the C. F. Weeber Manufacturing Works as a source of automobile shock absorbers and mufflers but no longer of steering gears. The capital of the Weeber concern was reported as between \$25,000 and \$50,000.¹⁰³⁸

Rails

Christian Weeber’s inventive mind extended to thoughts about improvements in transportation modes other than motor vehicles. On October 28, 1913, he received patent 1,077,236 for a new form of rail intended for use by railroads. A United Kingdom patent, 17,617, for the same was invention dates from July 30, 1912.¹⁰³⁹ The idea to con-

struct a “composite rail consisting of double rails joined to provide a single surface but with stepped joints.” Think of a rail split longitudinally with the sections staggered so the end of one piece reaches the mid-point of the adjacent piece. Each car wheel would roll over two rails, with the jolt and the wear eliminated, where expansion joints separated rails butted at their ends. The Weeber design still allowed for expansion and contraction but without the single troublesome break.

Marion Weeber noted that the rail was “Manufactured in Albany, and a test track was laid by New York Central [railroad] between Albany and New York. Rail prevented train from jumping track.”¹⁰⁴⁰ Apparently, there was little additional interest in the Weeber design. The problems with butted rails ends continued until the widespread introduction of welded rail in the second half of the twentieth century. Interestingly, Weeber, in his United States patent, took cognizance of welded rail but noted that such “construction is very disadvantageous...in view of the fact that there is no room for expansion in case of an increase of the temperature and owing to the fact that, as a consequence, accidents are likely to result. Furthermore, a railroad constructed in this manner is very difficult to repair.” With his design, he also eliminated troublesome bolts and the possibility of expanded rails becoming cemented together through the rusting of fish plates (and of the rail subsequently spreading horizontally due to expansion). With his design, the “railroad may be repaired at any time by substituting new rails with-

¹⁰³⁸See columns 1 and 4003. (The pages are unnumbered. There are three columns to a page.)

¹⁰³⁹The British patent, issued to “Christian Frederick Weeber of 106 Manning Boulevard Albany N Y United States of Amer-

ica Automobile Builder,” was for “Improvements in and relating to compound railway and the like rails.” The patent was good for fourteen years with “Taxes due before 30th July 1916 and annually thereafter.”

¹⁰⁴⁰Inventory of items donated to the New York State Museum in 1970. The accession number is H-1970.110.

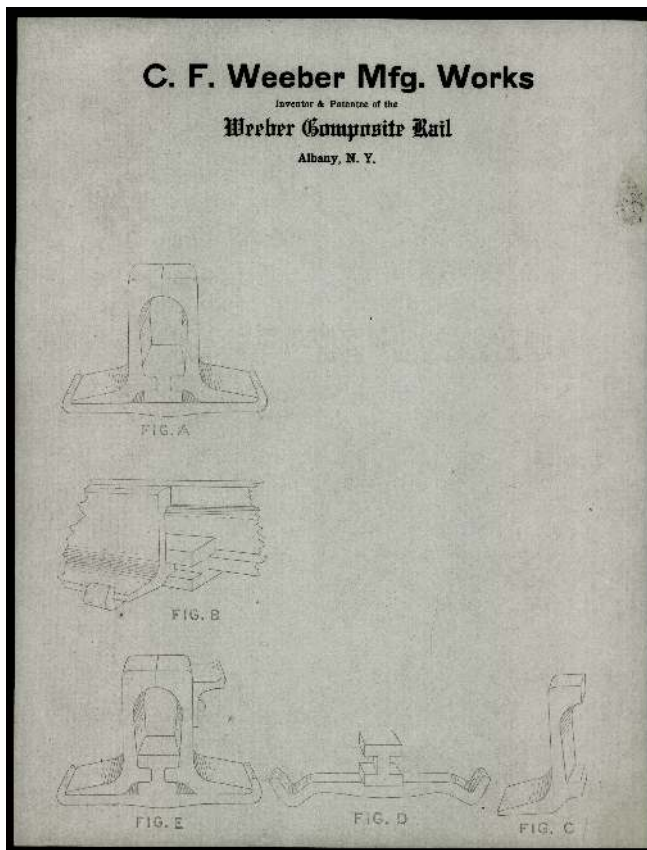

Figure 16.1: Letterhead advertising the Weeber rail joint. NYSM Collection, H-1970.110.20A.

out the necessity of discontinuing the operation of trains."¹⁰⁴¹

Traction Rings

Traction rings, a product of the 1910s, perhaps were Christian Weeber's most successful invention of the last two decades of his life. Patent 1,202,460, for "Traction Devices," was granted on October 21, 1916. A Canadian patent, 189,838, followed on April 22, 1919. By 1917, production occupied a part of the Central Avenue facility as *The Argus* said in February. "In the shop of the company at the present time is manufactured the Weeber traction ring, which, for tourists and winter work, is unexcelled."¹⁰⁴² Traction rings were prominent in Weeber's exhibit at the annual Albany auto show that month, as he advertised a new version "which

¹⁰⁴¹Successful welded rail installations pre-stress the rails and anchor the rails securely in accommodating the expansion factor.

¹⁰⁴²February 18, 1917.



Figure 16.2: Photograph of wheel fitted with a traction ring for publicity purposes leaning against the show window of the C. F. Weeber Manufacturing Works at 170 Central Avenue in Albany. NYSM Collection, H-1987.39.10.

clamps on the rim without drilling holes through Felloe."¹⁰⁴³ Another advertisement, described a traction ring exhibit at the auto show, where "all types and fixtures for every purpose" would be on display. In addition to the "special type for tourists which can be attached without drilling holes in the rim," there were to be "attachable extensions for heavy snow drift work."¹⁰⁴⁴ The *Albany Evening Journal* observed that with the traction rings, "snow banks three and four feet deep can be navigated."¹⁰⁴⁵

On February 20, Christian Weeber was at the show, where "personally in charge of the exhibition, [he] explained the device to a large and interested crowd.

¹⁰⁴³*The Argus*, February 23, 1917.

¹⁰⁴⁴*The Argus*, February 18, 1917. An advertisement with similar but not identical text appeared in the *Albany Evening Journal* for February 17, 1917: "We will display our complete line of TRACTION RINGS for every purpose, which will include a special ring for TOURIST, with clamps to attach without drilling through felloe. We will also have an extension attachment for extra heavy snowdrift work."

¹⁰⁴⁵February 24, 1917.

The traction ring was designed to overcome the difficulty now existing with pneumatic tires, pleasure and delivery cars, traveling through snow, sand and mud. It also prevents tires from forming depressions under the wheels of the car while it is not in operation.

The device consists of lugs, six in number, fastened to an elastic ring at an angle of 15 degrees. The lugs start flat below the hub lines of the wheel so as to depress obstruction [sic]. The action is not to lift the wheels out of depressions at once, but to divide it to one entire revolution of the wheel, making it six short lifts instead of one long one. The lugs depress the obstructions under the wheels instead of cutting it away and allowing the wheels to mire deeper.

If the weather is favorable this morning, Mr. Weeber will give another exhibition of the traction ring, operating a machine along the curbstone in the vicinity of the Armory and on Central Avenue.¹⁰⁴⁶

The next year, 1918, traction rings again were at the Albany auto show. A display advertisement in *The Argus* said the complete line of traction rings were to be on view with emergency clamps on all models. There would be traction rings for "every purpose" with demonstrations "Gladly Given." Agents were "Wanted Everywhere." Later Christian Weeber reported, "a very big trade in traction work" at the show.¹⁰⁴⁷

Marion Weeber wrote that the traction rings were made in Albany "from 1915, and franchised to American Traction Ring Co., White Plains, N.Y., 1917."¹⁰⁴⁸ A late 1920 letter in the Weeber file at the New York State Museum may suggest yet another manufacturer (or perhaps a competitor). In this letter, J. A. Gallagher of the Atlas Powder Company in Philadelphia, asked the B. & A. Machine Company at 203 W. 75th Street in New York to, "please forward us complete information concerning your device for trucks, consisting of blades fasted to rings bolted to driving wheel to give traction in mud, sand or snow, also stating what discount you will allow us as national users."¹⁰⁴⁹

¹⁰⁴⁶*The Argus*, February 21, 1917.

¹⁰⁴⁷February 17 and 21, 1918.

¹⁰⁴⁸Inventory of items donated to the New York State Museum in 1970.

¹⁰⁴⁹November 19, 1920. The Atlas letterhead notes the company was "Manufacturers of Explosives." There are no Weeber or other recipient notations on the letter.

Marion Weeber, recalling her work in the Weeber booth at the annual Albany auto show in 1924, said the traction rings, on display there along with other Weeber inventions, "were a miracle in deep snow and on icy [sic] and muddy roads. The U.S. Army equipped their trucks, with them during World War I."¹⁰⁵⁰

Tire Carrier

On January 31, 1922, Christian Weeber was granted patent 1,404,815 for a spare tire carrier, "especially for application at rear of car to be used in conjunction with another carrier." Tire construction had improved over the course of the previous twenty years but punctures remained common in the early 1920s. While most cars were equipped with a single spare, Weeber's invention added an extra. The device consisted of a flat iron band that was adjustable via a turnbuckle "or other such device to most sized wheels." The rim was held by the pressure of the inner band.

Marion Weeber wrote that the tire carrier was franchised to the American Traction Ring Company of White Plains in 1917 for manufacture and sale. The patent was sold in 1919 to the American Chain Company.¹⁰⁵¹

Tire Chains

Chains fitted to automobile and truck wheels for traction in slippery conditions were widely developed, marketed and used in the early days of motor vehicle transportation. Christian Weeber contributed to the field with an invention granted a Canadian patent, 237,207, in 1924. Weeber claimed, in part:

In combination, with a pair of parallel side chains, of a cross chain extending transversely there between, said cross chain comprising a series of interconnected links, hooks carried by the outer links of said cross chain for detachably connecting said cross chain to said side chains, and rings carried by said links of said cross chain, the inner diameter of said rings being greater than the diameter of the wire forming said links, the relative

¹⁰⁵⁰Marion Weeber to Geoffrey Stein, November 14, 1990.

¹⁰⁵¹Inventory of items donated to the New York State Museum in 1970. The accession number is H-1970.110.

size of said links and rings being such as well permit free movement of said rings.

In 1970, Marion and Gretchen Weeber, gave, among artifacts donated to the New York State Museum, a "sample hook used by Chris as a pocket piece with identification fob." Marion wrote that the chains were:

Manufactured at 170-172 Central Avenue, Albany, N.Y. from 1923. Chris made the machine that formed the hooks from wire. The non-skid rings on cross chains were tempered to extreme hardness. The steel of chains and hooks was given a final rust preventative wash of copper color.¹⁰⁵²

Fuel Systems

More intricate than tire chains or traction rings were the fuel induction systems for automotive engines Christian Weeber developed from as early, he said, as 1898 and continuing to the end of his life. Following a July 26, 1920, application, a patent for fuel systems, 1,624,007, was granted on April 19, 1927. An additional patent was pending at the time of Weeber's death.

While the initial patent was pending, the C. F. Weeber Manufacturing Works was listed as a source of carburetors in the *Thomas Register of American Manufacturers* in 1922 through at least 1925. In both years the Manufacturing Works were reported to still have a capitalization of between \$25,000 and \$50,000.¹⁰⁵³

In the documentation for his 1927 patent, Christian Weeber said:

My invention relates to a fuel system for internal combustion engines, and has, among other objects, that of finely atomizing the liquid fuel and by other means than that of the air current which supplies the air for the explosive mixture; and thereby overcoming the defect often occurring of a "wet" mixture due to insufficiently atomized particles of the liquid fuel carried along by the swiftly moving air current in to engine cylinder.

¹⁰⁵²Inventory of items donated to the New York State Museum in 1970. The accession number for the sample hook is H-1970.110.8.

¹⁰⁵³The 1922-1923 *Thomas Register* was the thirteenth edition; the 1925-1926 was the sixteenth. The Weeber listings appear on columns 1306 and 1487 respectively (three columns to otherwise unnumbered pages). In the 1923 *Register*, there are nineteen sources of carburetors with New York addresses.

Another object of my invention is to substantially vaporize the liquid fuel, and preferably before the admixture thereto of the main body of air, to form an explosive mixture.

A further object is to employ the exhaust gases of the engine as the atomizing, and, by reason of their heat, as the vaporizing medium.¹⁰⁵⁴

In brief, the patented system used a stream of exhaust gas piped from an engine's exhaust manifold to vaporize fuel in a second carburetor (the first being used by itself only to start the engine). The vaporized fuel from the second carburetor was mixed in the intake manifold with that coming from the first carburetor.

The further development of fuel induction systems resulted in a new patent application in 1928, number 299,378. A copy of a petition for special order¹⁰⁵⁵ survives in the New York State Museum collection. In the course of his request for speedy examination of his application, Weeber refers to his long years of experimentation and hints at a precarious financial situation, a condition confirmed by the state of his affairs at his death a few years later. In his petition to the Commissioner of Patents, Christian Weeber, or his patent attorney, Ernest D. Jansen of Albany, wrote on September 14, 1928:

The device disclosed in the... application is the result of along series of experiments and tests carried out by me and the design of which was to discover a sure and simple method whereby substantially full and perfect combustion of the liquid fuel generally used or burned in internal combustion engines could be insured, and a saving in the necessary amount of fuel be effected.

These experiments and tests covered a period of thirty years, I have started experimenting along this line in 1898, and continued to the present time. My principal object has always been the conservation of fuel, which of late years has been very generally recognized as a necessary move if our country is not to face serious shortage before many years.

On a number occasions [sic] during the time I was engaged in these experiments I have succeeded in devising, and have had in operation device which greatly improved the

¹⁰⁵⁴Patent No. 1,625,007, April 19, 1927.

¹⁰⁵⁵H-1979.23.17, the gift of Marion Weeber Welsh and R. Gretchen Weeber.

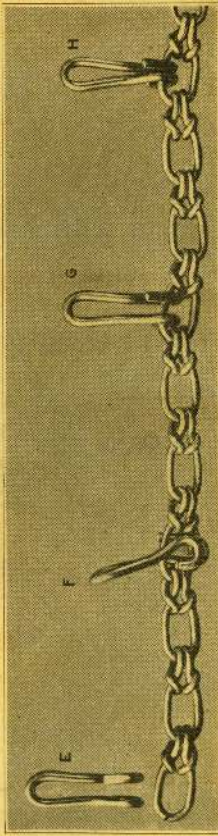

DIRECTIONS FOR OPERATING THE WEEBER QUICK ATTACHABLE AND DETACHABLE HOOKS

- E Shows hook loop spread.
- F Shows same passing through side chain link with hook side first.
- G Shows hook in place after quarter turn to right.
- H Shows hook after loop is compressed with pliers so to bring the hook ends close together. This makes operation complete. Any pull on cross chain aids to keep hook loop closed. To remove, spread hook loop and turn to left and trick is done.

WEEBER
Improved Tire Cross Chains

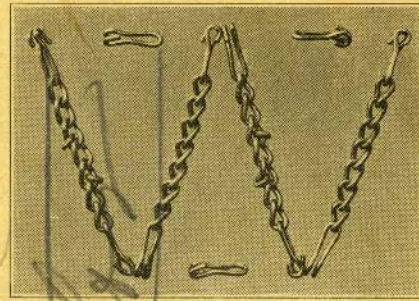

A quality chain that wears well and gives added safety and convenience to chain equipment.

MANUFACTURED ONLY BY
C. F. Weeber Mfg. Works
ALBANY, N. Y., U. S. A.

FOR SALE BY

Handwritten: 119 April 40 H 1923

7011072A

1923

Figure 16.3: Weeber brochure for tire chains, 1923. NYSM Collection, H-1970.110.72A

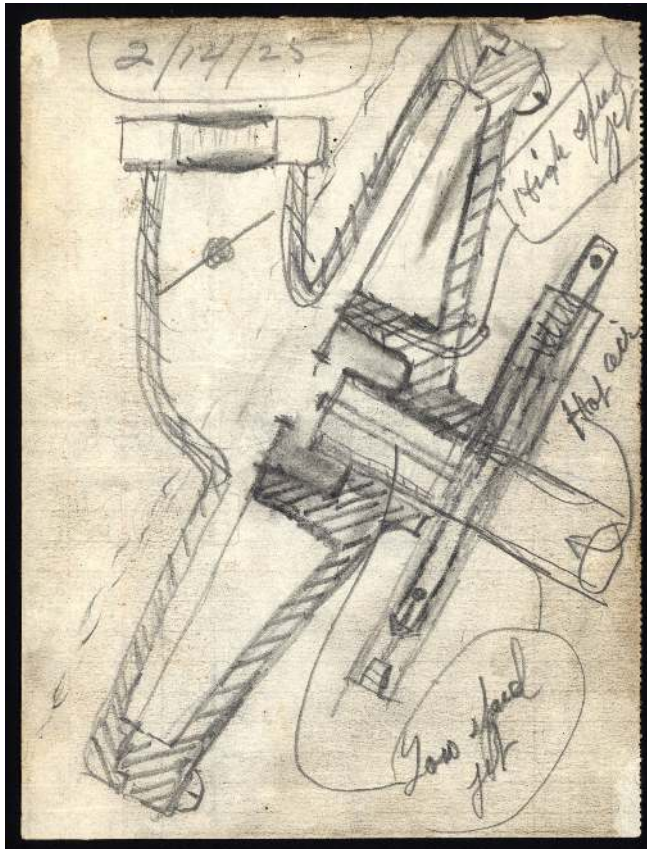

Figure 16.4: Drawing of carburetion arrangement, February 14, 1925, of the “Fuel Transforming System.” Marion Weeber called this one of her father’s “work bench sketches.” NYSM Collection, H-1979.23.6.

combustion of, and effected a considerable saving of fuels which at the time were generally burned in internal combustion engines; but these earlier devices were either too expensive, too complicated, or were rendered obsolete by changes in engine designs or in the general characteristics of the fuels which were generally available, before I was able to reduce the devices to a satisfactory commercial form.

As I was thoroughly convinced that I was working along the right line to get the results desired, I have for the past three or four years devoted as much of my time as possible (somewhat to the detriment of my affairs) to the perfecting of the device which I have disclosed in the application above referred to, and which I am sure does what I started out to accomplish, i.e. improve the combustion of fluid fuel mixtures when burned in an internal combustion engine arranged in accordance with my invention and provided with my device to such an extent that a very considerable saving of fuel is effected; carbon deposits eliminated; the temperature of the motor kept at a satisfactorily low level and without loss of power; and a smooth, flexible performance insured.

To start production of my device in an up-to-date manner, and on a scale which will insure a low manufacturing cost and so permit the device being made available to the public at a reasonably low price, will require a considerable expenditure of time and money, and before proceeding I very naturally wish to reasonably [be] sure that the device will receive the protection of a patent of the United States.

My experiments were finished some months ago, in so far as the method was involved, and a satisfactory device for use on certain makes of motors was designed, and tested, and preliminary arrangements of a financial nature were made. After making the preliminary arrangement, which were based on the supposition that I was nearly ready to proceed with manufacture, and on a commercial scale, it developed that there were certain makes of motors which would require certain changes to me made in the device in order that it would be flexible enough to work on any usual motor. These changes required further experimentation and test and resulted in a further delay in the filing of my application.

Since receiving the filing receipt, which gave information as to the division to which the application had been initially assigned, I have



Figure 16.5: This wooden model of an engine was used to display the pieces of a later fuel transforming system, apparently the version using a two-way valve. The device is marked “Weeber Liquid Fuel Transforming System.” NYSM Collection, H-1933.6.2.

examined the report of the condition of business in the Patent Office and judge from it that eight months or more will elapse before my application will come up for examination in the regular [sic] course.

As a delay of the length waiting for an action by the office, would not only delay the time at which I would with reasonable safety commence business of manufacturing and distributing my device, but may endanger my financial line to a very considerable degree as well, I would respectfully pray that you will direct the examiner to make my application “special” and examine it as expeditiously as is possible.¹⁰⁵⁶

Jansen was sent a letter, dated October 1, 1928, and written over the stamped signature of patent commissioner Thomas E. Robertson. It stated that the petition for speedy consideration was denied, the “facts given are not sufficient to warrant the taking of this . . . out of its turn and placing it ahead

of hundreds of others which were filed before it. . . .”¹⁰⁵⁷

A surviving typed copy of the application itself has marked in pencil, “Notes made by CFW 5/7/30.” This document mentions the “pre-heat” of a fuel charge for “increasing the combustibility of fuel mixtures initially made by a carburetor” but resulting in detrimental high temperatures that “may be actively destructive to valves etc.; and which seriously interferes with the proper lubrication of the piston and cylinder wall.”

Weeber’s new fuel mixture route is described as follows:

In general my improved method of handling and treating fluid fuel mixtures supplied to an internal combustion engine by a suitable mixture forming device, generally a carburetor, [sic] consists in allowing a comparatively small portion of the fuel charge after it has entered the engine cylinder and coming into contact with the hot valve, spark plug, piston, and cylinder and combustion chamber walls [sic] has absorbed heat

¹⁰⁵⁷ Thomas E. Robertson to Ernest D. Jansen, October 1, 1928. Jansen is listed in the Albany city directories as a patent attorney and mechanical engineer.

¹⁰⁵⁶ Ibid.

therefrom, to leak out of the cylinder by the compression stroke of the piston and into an auxiliary passageway or by-passage leading from the combustion chamber to a point in the intake manifold (or other fuel inlet passageway) ahead of the usual inlet valve; the heated fuel mixture as it escapes through the by-passage being further atomized, and its rate of travel speeded up so it will leave the passageway and reenter the manifold as a hot jet of highly atomized fuel. It is of course obvious that any appreciable outflow through the by-passage should be prevented during most of the combustion period.

I now believe it preferable to have a portion of the fuel charge enter the combustion chamber by way of this by-passage as by doing so I maintain an alternating flow through the valve assembly which will tend to keep the ports and mechanism free. I may also permit a small amount of the products of combustion to enter the by-passage, through the atomizing port, a minimum leak insufficient to to [sic] expel the fuel mixture from the by-passage, but sufficient to keep up a resurging through the valve assembly that will tend to the the [sic] restricted ports therein free from sediment which might impair their proper functioning.¹⁰⁵⁸

Jansen died on March 6, 1929.¹⁰⁵⁹ Within a few weeks, Weeber had secured the services of Edward H. Yeager, a patent and trade mark lawyer in Washington, D.C. On April 27, Yeager wrote that he had the power of attorney "in the matter of your pending application" and had received a \$25 check on account. Yeager planned to "copy the record in your case in the Patent Office" and then "take action in the same. You may rest assured that I will carefully review the entire case before taking any action, and that I will exert my best efforts on your behalf."¹⁰⁶⁰

¹⁰⁵⁸Weeber, in the margin of the typed document, wrote "chemicalized" with a line to "atomized" indicating a desired change in wording. He also suggested the change in eleven other places where "atomized" had been typed. The document, a gift of Marion Weeber Welsh and R. Gretchen Weeber, is H-1979.23.21 in the New York State Museum collection.

¹⁰⁵⁹Albany city directory, 1929 ("Year Ending July 1930").

¹⁰⁶⁰Edward H. Yeager to C. F. Weeber, April 27, 1929. Weeber noted in pencil on Yeager's letter, "Ans. 4/30/29 Sketch sent Copies." In the Weeber collection at the New York State Museum is an undated "special offer" solicitation letter from William N. Moore, another patent attorney in Washington, D.C. He offered domestic patents for \$12.50 or "one-half my

A carbon copy of a letter from Weeber to Yeager survives, one of very few copies of outgoing correspondence from Weeber's professional career. Dated April 30, 1929, the typed letter is marked "CFW/MW" at the bottom, indicating that Marion Weeber was the typist for her father. Christian Weeber observed that he was enclosing a sketch of the "automatic type" transformer with his communication. His letter suggests the continuing development of the fuel system.

In further reference to my last letter I am herewith inclosing sketch of cut of automatic type, and you will note that it is a very convenient arrangement.

It has a stroke adjustment for volume and one also for tension. If you can make the claims read to cover this slight change it would help very much. It was done as stated before to prevent fouling. As you will note the spring cage has an assembly of its own and has no through circulation, therefore it is necessary for all gases coming and going to travel around it and you will note that the gases do not travel through the valve stem as shown on drawing, but around it. It has proven that after a full years test, not a particle of any objectionable matter has entered the spring chamber, more than a slight lamp black order soot, which would be in the line of a lubricant instead of doing harm.

As stated before in my former letters, I am very anxious to get this matter to a head so I can start manufacturing. I thank you in advance for every effort you can make to speed the matter as well as getting the valuable claims allowed. Hoping to hear from you shortly, I am.¹⁰⁶¹

Yeager wrote again at the end of June, enclosing a new patent application amendment. He noted that he would not file the amendment until Weeber had approved it.

You will note that in said amendment claims 17 to 20 have been carefully formulated to protect both the method as well as the combination of elements employed by you, to obtain the so called alternating action of the fuel within the by-pass, and that claims 21 to 25 inclusive are the same as the claims contained

usual fee." Canadian patents were \$17, British \$25 and German \$30.

¹⁰⁶¹Christian F. Weeber to Edward H. Yeager, April 30, 1929.

in the amendment previously forwarded you, and direct to the valve construction per se.¹⁰⁶²

Christian Weeber continued to develop his fuel transforming system and contemplated a new patent application as late as the summer of 1931. His patent attorney, Yeager, wrote to him then that “any and all improvements which you have made in the valve construction should be incorporated therein.” Yeager continued:

I note that you are contemplating protecting an improvement in the manifold that runs from the transformer unit to the jet in the engine intake manifold, but this subject matter would have to be covered in a separate application, as it is a distinct and separate matter from the valve construction.

Trusting that you will advise me of your wishes in these matters just as soon as possible, I beg to remain...¹⁰⁶³

The State Museum collection houses a copy of the amendment dated in pencil June 27, 1929, to the application filed on August 13, 1928. In response to “official action of March 23, 1929, amendment is hereby made as follows: Cancel the claims and substitute...” There follow nine claims numbered seventeen through twenty-five. A penciled notation, not in Christian Weeber’s hand, notes, “Claim 17, 18, 19 Allowed 2/21/31.” There are a few changes in Weeber’s hand, notably switching from “atomize” to “chemicalize.” As a summary of the claims, number twenty-five is reproduced here.

In an internal combustion engine, the combination with a cylinder having a bore communicating with the combustion chamber, of a valve casing associated with said bore and having spaced ports, said valve having a cupped extremity in align with said bore and also characterized by a restricted leakage passage to permit the escape of fuel from the cylinder when seated to close one of said ports, resilient means for normally holding the valve so seated, and said restricted passage being rendered ineffective for the purpose specified when the valve is seated to close the other of said ports.¹⁰⁶⁴

¹⁰⁶²Edward H. Yeager to C. F. Weeber, June 27, 1929. Weeber noted in pencil on the Yeager letter, “Ans. 6/29/29 Copy.”

¹⁰⁶³Edward H. Yeager to C. F. Weeber, July 6, 1931. Yeager’s office was in the Victor Building in Washington, D.C. His letterhead notes he was a “Patent and Trade Mark Lawyer.”

¹⁰⁶⁴*Ibid.*

Yeager wrote Weeber in February 1931 to tell him that the patent examiner had allowed three claims in the pending application so Weeber could “see the scope of protection afforded you by these claims.” He continued by advising Weeber that to protect the valve he would have to file a separate application.

Then Yeager mentioned that he would “be pleased to hear from you in regard to this matter as soon as the corporation is formed, and decides to take up the matter of protecting the valve construction.”¹⁰⁶⁵ One assumes Weeber had a corporation to exploit the fuel transformer in mind rather than the “Utilizer” helicopter, also the object of an intended corporation (see below).

The final surviving letter from Yeager to Weeber is dated August 15, 1931. In it, Yeager said that “action was taken in the matter of your pending application...and...I accepted the allowed claims as you suggested in your letter dated August 6, 1931.” Yeager continued by stating he expected “Official Notice of Allowance” within a week or so and would mail the notice to Weeber. Finally, Yeager acknowledged the continuing adjustment of the valve with “slight changes.” When Weeber is “ready to proceed with this case I will be pleased to hear from you.”¹⁰⁶⁶

The functional, if not economic, success of the Weeber Transformer is attested by a number of letters sent to Christian Weeber by users. One pleased purchaser was Edward Osborn, the superintendent of the stationery and printing department of The Delaware and Hudson [railroad] Company. In December 1929, Osborne sent Weeber a check to pay for the device installed on his car two months before.

I am very much pleased with the way it operates. It not only saves gas, but I believe it saves oil. I had the oil changed shortly

¹⁰⁶⁵Edward H. Yeager to C. F. Weeber, February 21, 1931. The third of the allowed claims reads, “In an internal combustion engine, a by-pass establishing communication between the cylinder and a point in the fuel inlet ahead of the usual inlet valve, whereby a portion of the incoming charge is by-passed around said valve during the suction stroke, and means controlling the communication between the by-pass and cylinder, whereby a portion of the charge is permitted to escape from the cylinder during the compression stroke, and prevent such escape during periods of high pressure within the cylinder, said escape portion of the charge reentering the fuel inlet in the form of an atomized jet.”

¹⁰⁶⁶Edward H. Yeager to C. F. Weeber, August 15, 1931.

after you installed [the] Transformer, and it seems to be as clear today as the day I had it changed. You did not mention this to me, but I feel it is my duty to tell you the results I obtain from its use.

As you know, my son drives the car more than I, and he is very much enthused with the device. He says it makes the car start easier, gets away quicker, increases the compression, and has all kinds of power. I was riding with him a week ago and he was driving fifty-eight miles an hour and I asked him to slow down, as I did not care to ride so fast. He said he did not have the accelerator half way to the floor. He also told me that he did not dare to feed gas the way he was in the habit of feeding, as he would be traveling thirty to thirty-five miles an hour before he realized it. You will bear in mind that the car mentioned is a 1923 model.¹⁰⁶⁷

H. [Henry] P. Snow, writing about the fuel transformer in 1931 on Johnson & Johnson letterhead, corrected the printed New Brunswick, New Jersey return address with that of his residence at 7 Ten Eyck Street in Albany. Snow claimed:

I have been using one of your Fuel Transformers on a Big Six Studebaker for the past two years and do not believe that I would care to drive a car without one. It gives me better mileage on gas on average of 16 miles to the gallon, have less carbon, no evidence of knock on a hard pull, can throttle down to 2 miles an hour on high in traffic and not obliged to shift into second gear. It makes a smoother running motor, quicker on pick up and an easier car to handle.

I hope every Motorist will equip his engine with this device as it soon pays for itself.

Wishing you all the success possible,¹⁰⁶⁸

Another Transformer user was Edwin S. Chalker, who operated Chalker's Towel Supply and Overalls in Rensselaer. He wrote to the Weeber Manufacturing Works on February 17, 1931, that since installing the device "on my Willy [Willys] Knight sedan I can hardly believe that I am driving the same car. It has materially increased the gas and oil mileage and has given the car a lot more

power and pick-up. This is especially noticeable at low speeds."¹⁰⁶⁹

Another February 1931 testimonial came from Conrad Hammann. The date similar to Snow's and Chalker's letters suggests that Christian Weeber solicited the documents. In any case, Hammann, an assistant Albany city engineer, wrote:

In November 1929 you installed on my 1925 Dodge, the Weeber Fuel Transformer, and since I have enjoyed better performance in my car.

I cannot help but notice the increase in power, low throttle performance, saving in fuel and freedom from carbon.

I am also impressed with the little or no attention it requires. I think you checked it up but once since its installation and found it in perfect working order.

It surely is most valuable in these days of congested traffic especially in the cities, when low throttle performance is so vital.

If you wish you may recommend me, to any prospective purchaser as one satisfied in every way with the transformer.¹⁰⁷⁰

On February 1, 1979, after conversing with Marion Weeber in her New York City apartment, the author recorded information received from her about the fuel system.

The fuel transforming system for which the museum [already] has a model [H-1933.6.2] went through a development period. At the time of Weeber's death, several examples of a later model were in use, one on Weeber's own car, a Studebaker. Others had been installed on a Washington Avenue (grey line) bus line in Albany on a gratis, demonstration basis. About 1,000 machined pieces were found in W's shop after his death. (M showed us the part on the system removed from her father's car and which she will donate to the museum). Unfortunately for W, there was little demand for the device which decreased fuel consumption about 20% and decreased pollutant output from gasoline powered engines. A patent application was withdrawn

¹⁰⁶⁹E. S. Chalker to C. F. Weeber Mfg. Works, February 17, 1931. One might wonder about the possible long term effect of the transformer keeping internal surfaces clean on the sleeve-valve Knight engine, which was known for improvement in efficiency with the build up of "carbon" deposits, this in contrast to the operation of poppet-valve equipped motors.

¹⁰⁷⁰Conrad Hammann to C. F. Weeber, February 2, 1931.

¹⁰⁶⁷E. Osborn to C. F. Weeber, December 19, 1929.

¹⁰⁶⁸H. P. Snow to C. F. Weeber Mfg. Works, January 31, 1931. Snow is listed as a commercial traveler in the city directory.

after W's death. M will give us the patent correspondence, also.¹⁰⁷¹

Marion Weeber drew a "sketch of Device Removed From Chris Weeber's Experimental Studebaker After His Death, September 28, 1932" for the State Museum. She noted that this system, for which a patent had been applied (serial number 299378), was manufactured and sold by the C. F. Weeber Manufacturing Works from 1929 to 1932. Its components were made of "machined turned steel," cast brass and copper tubing. In addition to the fuel system itself, Marion drew a gasoline tank float "for testing consumption." Marion wrote elsewhere that the "Liquid Fuel Transforming System...with variations" had been demonstrated and sold each year at the annual Albany auto show from 1927 through 1932.¹⁰⁷²

In the same essay, Marion Weeber stated that the fuel system was being tested on the helicopter model her father was building, the "Utilizer" shop prototype. "Different models being made for use on the Helicopter and autos. Airplane 3 cyl. or 9 cyl. air cooled engines in 1932 were operated through one carburator [sic] and one manifold just like an ordinary automobile engine."

The "Type C" fuel transforming system was intended for broad production. Among design surviving sketches in the New York State Museum collection is one dated June 25, 1930, which calls for one-thousand of each of the "Type C Parts."

In 1973, Marion Weeber wrote to the author about a visit she'd had from automotive writer and publisher L. Scott Bailey. He was curious about the fuel transforming system.

Mr. Bailey is very interested in this, as apparently Chris was a pioneer in attempting to awake the public interest in the conservation of fuel and the pollution problem to which the internal combustion engine was contributing. You [New York State Museum] have an exhibit model, which was shown at the Albany auto shows. This attachment was manufactured at 172 Central Avenue, Albany and many area cars were equipped at a cost of about \$75 retail price. The Albany Transit Buses were also equipped with special testing

¹⁰⁷¹February 1, 1979. There is a drawing of one of the pieces on the original New York State Museum memorandum "after his death" inserted into the file.

¹⁰⁷²Marion Weeber, "List of Artifacts and Papers given to N.Y. State Museum, Feb. 6, 1979."

models (the grey line that ran on Washington Avenue) I have testimonial letters from purchasers as to the performance of the device. I have an original casting for the Fuel System... which we will contribute to the permanent Museum Collection if you want it. You may keep the photos. This subject being so timely [at the time of the 1973 oil crisis], should make an interesting State exhibit.¹⁰⁷³

In 1984 Marion Weeber wrote:

In 1970-71 I did some research on air pollution caused by cars.

I was interested to know at the time, what progress the new cars had made toward control of exhaust emissions.

Now that I'm clearing my files, I thought this literature might be of interest to you as the problem is a current one.

You have some early data, a working model and the patent granted to Christian F. Weeber in 1927, "Fuel Systems for Internal Combustion Engines," which system recycled the fuel, much as they are doing today, and produced remarkable results.¹⁰⁷⁴

In 1990 she also noted that:

...there is so much current news on air pollution [sic], you might consider exhibiting the early model of the "Liquid Fuel Transforming System." You may recall this system re-circulated the exhaust for more economical driving and purification. You also have patent papers on this, and testimonial letters from concerned citizens of the time.

The cost of the attachment to a car seemed too high for popular acceptance. Even the Albany Bus Transport Co. turned it down. Few citizens seemed to care about pollution [sic].¹⁰⁷⁵

In 1930, Christian Weeber said of his fuel system, "It breathes like a human being. In fact, its

¹⁰⁷³Marion Weeber Welsh to Geoffrey N. Stein, November 15, 1973. The letters and the casting subsequently were donated to the State Museum by Marion and her sister, Gretchen Weeber.

¹⁰⁷⁴Marion Weeber W. [sic] to Geoffrey Stein, June 16, 1984. Marion Weeber included with her letter to the author a collection of publications from the 1971 period about automobile emissions control. The author responded to Marion Weeber on June 25, 1984, writing, in part, "I remember noting the re-circulation component of the Weeber fuel system, also, and remarking to myself that a similar device had come into use with the advent of pollution control. Your father was a far-sighted man. I remain very much pleased that many relics of his career are in the Museum collection."

¹⁰⁷⁵Marion Weeber to Geoffrey Stein, April 4, 1990.

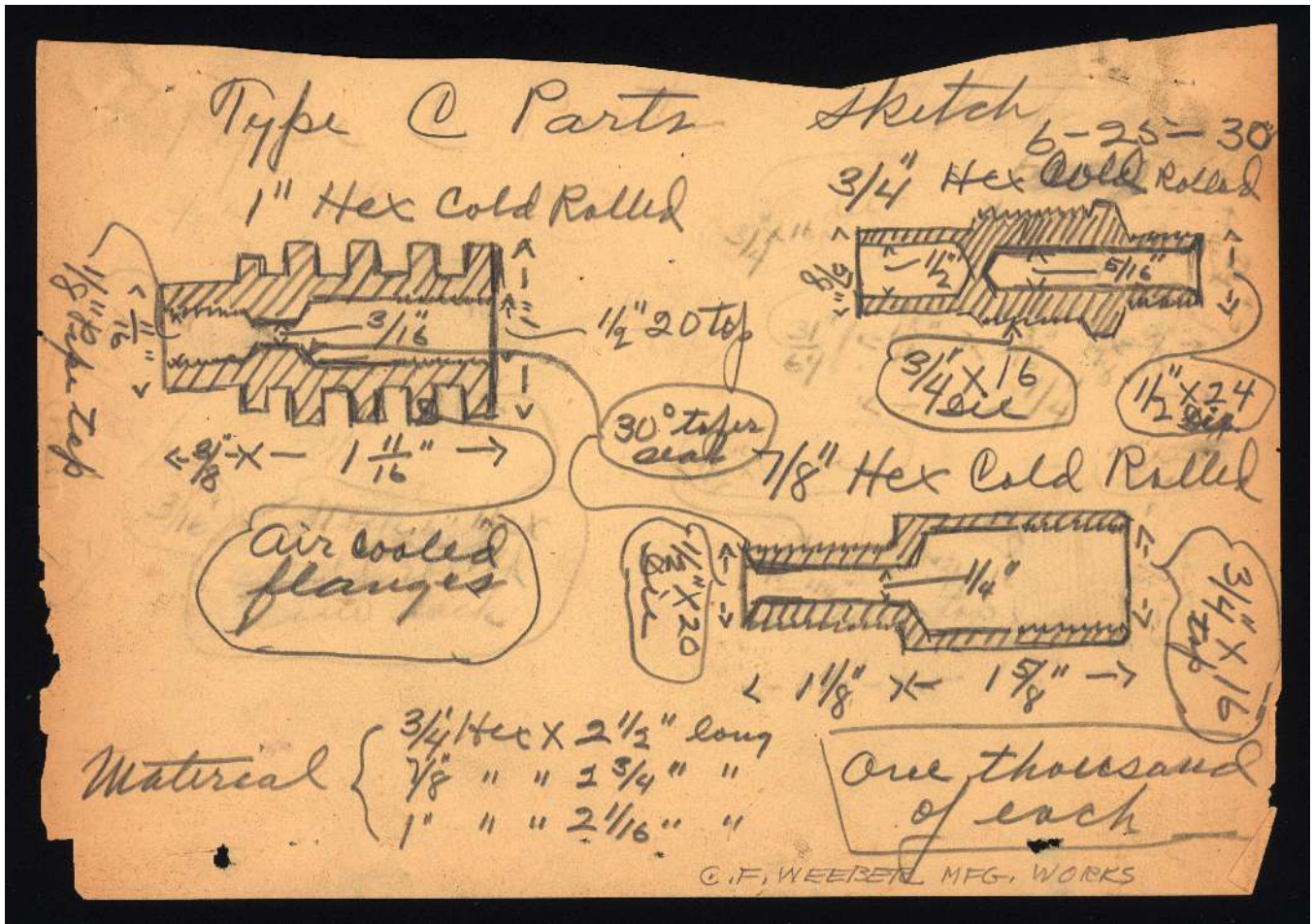

Figure 16.6: Drawing, transformer parts, c. 1930. Sketches and notes in Christian Weeber's hand showing parts needed for 1,000 "Type C" Liquid Fuel Transforming devices. NYSM Collection, H-1979.23.11.



Figure 16.7: 1927 Drawing of Christian Weeber done by Marion Weeber. NYSM Collection, H1974.122.1-2.

principle is much after the fundamentals of human life.” The *Albany Evening Journal* said of Christian Weeber, “He talks of machines breathing, living, acting; of their various parts, the way a physician talks of the part of a body or a psychologist of the mind.”¹⁰⁷⁶

“Utilizer” Helicopter

Christian Weeber said that similar to his fuel transforming origins in the 1890s, flight—the other grand work in the last years of his life—also interested him since those early days. In the late 1920s and early 1930s, he sought to develop helicopter flight, a system he called “Utilizer.”¹⁰⁷⁷ Marion Weeber wrote:

He stressed the economy of this approach to flying. That it would *make use of*, [sic] to the utmost all properties involved and contribute a *useful and needed* service. He mentioned rescue operations at sea, in remote areas, and forest fire fighting. He saw the roads becoming

¹⁰⁷⁶Quoted in the *Albany Evening Journal*, November 24, 1930.
¹⁰⁷⁷Marion Weeber to Geoffrey Stein, July 5, 1975, in response to a query from Stein about the Utilizer name said, “You ask how the name ‘Utilizer’ was developed? C.F.W. named his flying machine.”



Figure 16.8: The fly ball governor, which Marion Weeber called “the only one in existence”, was used by Christian Weeber in his Utilizer experiments. The device is engraved by hand inside “XYII.” NYSM Collection, H-1974.36.1.

congested [sic] with traffic and wanted to fly home and land in his own back yard, or on the flat rooftop of his garage.

He had a passion for helping people, making life happier, more comfortable and mobile. Strange how he worked around the clock, all his life, and sacrificed his own comfort and fortune for this purpose. I do believe however that he was completely happy in his work and accomplishments.¹⁰⁷⁸

Marion Weeber told of her father’s efforts to achieve flight in the 1890s. She described his efforts during the period after his studies at Pratt Institute and before he opened his Albany bicycle shop. During that interim:

He worked at General Electric as a machinist for about a year to gain experience. He stayed with his older brother Louis and sister-in-law Mary, who lived in Schenectady. As I heard the story, he whittled out of wood models of flying machine parts in the kitchen by the old fashioned black coal range every evening. Mary was always after him to clean up his shavings, which flew all over. One morning in exasperation she threw all the parts into the coal range.

After that he dropped the project and soon became involved in building bicycles and the automotive development. Years later when I was a little child, I kneeled quietly beside him in the garden to watch a hummingbird among the flowers. He then told me that was

¹⁰⁷⁸Marion Weeber to Geoffrey Stein, July 5, 1972.

the principle he was working on for a new type of airplane, and he showed me wood and metal model parts that I, of course, did not understand.¹⁰⁷⁹

Louis and Mary's daughter, Gladys Weeber Simmons, confirmed the story of the 1890s flying machine models.

According to Mother, Uncle Chris spent his evenings whittling on what he said were parts for a flying machine model. My mother was less enthusiastic about this project as it fell to her to try to sweep the shavings out of the rug each morning and according to her it was no easy job. She did prevail upon him to put down a newspaper when he worked but those perverse whittlings just scattered everywhere.

One morning when she was (as we would say) "fed up," she gathered up all the parts and burned them!

I don't know what Uncle Chris' immediate reaction was, but years later he used to tell with gusto how "Mary set back my flying machine project by two years or more."¹⁰⁸⁰

Christian Weeber's continuing interest in flight is suggested by his subscription to the French-based journal, *Automobilia and Flight* in 1909. Weeber believed that in addition to the journal, he was to receive some photographs and a text by Homan. According to Frank D. Phillips, manager for the magazine in New York City, the man selling subscriptions in Albany apparently had no authority to offer such a book. While the erstwhile agent, Mr. Stubbs, failed to submit Weeber's payment for the magazine, Phillips wrote, "We will

¹⁰⁷⁹Marion Weeber to Geoffrey Stein, July 22, 1975. In 1971, Marion Weeber wrote the author (May 6, 1971), telling this story thus: "About 1894 Chris lived at his brothers' [sic] home in Schenectady while he worked at G.E. for about six months before going into business in Albany. His sister-in-law, Mrs. Louis Weeber, later told me that he sat in the kitchen and whittled every evening, making strange looking things out of wood. He told her it was an Air Ship. She said she got sick and tired of sweeping up after him, and one day burned his models in the coal range, and that put an end to it, at that time. I asked her what he said. 'Mary, you just set the world back about 100 years.'"

¹⁰⁸⁰Gladys Weeber Simmons (Mrs. Robert M. Simmons) to Marion Weeber, July 11, 1975. Marion Weeber, in a letter to the author on July 22, 1975, noted that Gladys was about "15 years older than me. . . . She attended N.Y. State College for Teachers in Albany. . . and while a student moved to California with her mother, because of ill health. She finished college there and taught in California public schools for many years. . ."

make good to you, even though we did not receive your money. . . . In reference to the pictures, we shall have to ask you to wait a little longer as the cuts necessary for the printing of these pictures were consigned to a former manager of ours, and we have had to write to Paris to have them reconsigned to us."¹⁰⁸¹

Funding for the helicopter project was a problem for Weeber. Having given up the automobile sales and repair business (renting his building at 170-172 Central Avenue), he needed income to support the development of the invention. Marion Weeber said, "Many letters were written during the years of development seeking interest in the project. I typed most of them during my after classes and summer vacation stints, in my High School years."¹⁰⁸²

Marion Weeber also noted that:

Dad had finished testing a successful model of his Helicopter in 1928 and applied for patents. I know he tried to form of a corporation to finance the building of a full size model and their manufacture. Money was very tight at that time, so he apparently tried to raise enough on his own assets.¹⁰⁸³

Another time Marion Weeber wrote to the author:

This was the depression period. He had financial problems of his own, and all his attempts to interest existing Aircraft companies and G. E. had failed. Although he exposed many of his findings to them, he said he never revealed all the features of the "Utilizer" and dissembled it after each test, removing a part, because he did not trust his employees.

At the time of his death in 1932 he was planning to incorporate to develop and manufacture the "Utilizer" for actual service, and many local residents subscribed for shares. I

¹⁰⁸¹Phillips to C. F. Weeber at 272 Western Avenue, i.e., his home address, June 4, 1909. A previous letter, on May 28, 1909, asked Weeber to send the receipt for the subscription. The author does not know to what book the Homan name refers.

¹⁰⁸²Marion Weeber to Geoffrey Stein, July 5, 1975. She added, "If I locate any copies I will save them for you. "

¹⁰⁸³Marion Weeber Welsh to Geoffrey N. Stein, November 11, 1970. Marion Weeber continued (as quoted in the text earlier in the present work), "His usual way was to increase mortgages on his property and by bank notes (he had a line of credit). He had financed all of the experimental development for all his other inventions on his own."

an inclosing information sheet that accompanied a personal letter. Patent papers had been prepared on some features, but the patent and corporation were never consummated.

Although as a young girl I helped him in many of these experiments, where he tested the weight lift with models, I was not knowledgeable enough to put it back together after his death. Engineers and test pilots who took a look at the model said they couldn't understand it.¹⁰⁸⁴

In 1929, Washington, D. C. attorney Edward H. Yeager, who was occupied assisting in a patent application for the Weeber Fuel Transformer, wrote to Christian Weeber that he, Yeager, had noted:

You are about to incorporate the company to be known as the Weeber Aircraft Corporation, and that you contemplate visiting me in Washington in the near future to discuss some important matters in connection with the same.

I would be very pleased to assist you, but suggest that you wire me a day or two in advance of your visit so that I may arrange my calendar accordingly.¹⁰⁸⁵

As he sought investors, Christian Weeber himself wrote, after noting his interest and experiments in flight "since I left Pratt Institute... in 1893:"

I was always a believer in an airship that could Hoover [sic] about slowly and land vertically if necessary, and take off again in the same way, or remain stationary in the air. My ambitions appear to have been realized in several of my inventions recently, and particularly in one.

This I call THE UTILIZER. The test, in my laboratory, with electrically driven motors mounted on accurate scales, shows that with apparent ease the lift in dead air is much greater than any take off at high speed with the most modern airplanes I have on record (and that with favorable flying conditions) The Utilizer also has provision to operate when the motor goes dead, by either pilot or passengers, on gradual or vertical landing with apparent safety. The cost of producing the Utilizer Type Ship will not necessarily be high priced, and as it now appears, no high powered motors will be needed which will mean less weight in motors and fuel.

As you note by the Subscription Blank, I am incorporating to develop the above invention in proper size and ships suitable for actual service. It is needless for me to state, what a successful trial flight of this nature will mean to value of stock, and will be internationally known as well.

The Shares priced at \$10.00 each makes it possible for anyone to invest in this development without burden. I believe you will be glad to have an industry of this nature located here.¹⁰⁸⁶

Christian Weeber's death ended all Utilizer activity. While artifacts of Weeber's automotive projects in the 1930s made their way into the New York State Museum, it was not until the 1970s that the relics of his helicopter experiments also made their way there. In 1974, Gretchen and Marion Weeber gave the State Museum a "Mechanical Governor of the Weeber 'Utilizer' Helicopter, circa [sic] 1928."¹⁰⁸⁷ Marion described this as the following:

A gyroscope, with vibrating reed encased in a brass casting. The operating spindle is partly rusted away but I cleaned it up. This is the original and only existing part for the Utilizer helicopter, circa [sic] 1928.

I am also accumulating the scale model parts and work bench sketches and data, written and drawn by Chris, which show the successful test ratios, lift, etc.¹⁰⁸⁸

In 1975, the Weeber sisters donated the models and sketches Christian Weeber produced as he experimented with the Utilizer idea. In general, the sketches are rough and fragmented. They likely meant much more to their creator than to the casual observer many years later. Marion noted that the sketches were "made on scrap paper kept on Clip-boards in the machine shop and laboratory. All are his hand and establish dates."

The three-dimensional objects similarly are generally unimposing. Perhaps most interesting visually is what Marion labeled the "operating Vibratory Rotor, on motor and plate of test frame (successful test #32)" She suggested that if the museum

¹⁰⁸⁶Christian F. Weeber, "Information Regarding Weeber Aircraft Development" (mimeographed handbill; dated "About 1930" by Marion Weeber, who probably typed the original document).

¹⁰⁸⁷Marion Weeber Welsh to Geoffrey Stein, March 22, 1974.

¹⁰⁸⁸Marion Weeber Welsh to Geoffrey N. Stein, November 15, 1973.

¹⁰⁸⁴Marion Weeber Welsh to Geoffrey N. Stein, May 6, 1971.

¹⁰⁸⁵Edward H. Yeager to C. F. Weeber, June 27, 1929.

were to plug it in, it “would have an interesting display.”

She continued by noting that:

Originally the indoor test for lift-weight ratio, used three electric motors and 2 scales. Mother left it set up for a year and showed it to prospective buyers, airplane and glider manufacturers, but they said they didn’t understand it. I’m sorry the models are in such rusted condition, but Mother stored them in the cellar of her home all those years.¹⁰⁸⁹

¹⁰⁸⁹Marion Weeber Welsh to Geoffrey Stein, May 6, 1975.

CHAPTER 17. DEATH AND LEGACY

Christian Weeber died at age sixty. While his medical history before the final illness is unknown here, at one point in his life he was concerned about his health. He responded to a solicitation from J. Edmund Thompson of Worcester, Massachusetts, in February 1910. A letter to "C. F. Weeber, Jr." at 170 Central Avenue spoke of two types of men. One was stout, short of breath and prone to taking pills for indigestion. The other, one of few, was "a human dynamo and energizes all with who he comes in contact." To find out how to become one of the latter class, Weeber was asked to return a card to Thompson. Weeber duly marked the letter, "Sent postal 2/9."

Worcester city directories of the 1910 period carried Thompson advertisements. His "Physiological Method of Exercise" promised to cure indigestion, constipation, headaches, bilious attacks, insomnia and nervous troubles and reduce weight by exercising the "great INNER MUSCLES (your vital organs)."¹⁰⁹⁰

Christian F. Weeber died on September 28, 1932. He had been ill at home for a week before going to a hospital for surgery for a "strangulation hernia." His heart, however, couldn't withstand the anesthesia, according to his daughter, Marion Weeber.¹⁰⁹¹ Albany Rural Cemetery records document the cause of death as "chronic myocarditis." Weeber's funeral took place at his home on Saturday, October 1, 1932, conducted by Dr. Chalmers E. Frontz, minister of the First Lutheran Church. In addition to his wife and daughters, three brothers, Emil of Albany, Edward of Stuyvesant and John of Yakima, Washington, survived him.

The Knickerbocker Press reported Weeber's death in a front page story complete with photograph.¹⁰⁹² *The New York Times*, in a short obituary dated September 28 and bylined "Special to *The New York Times*," said Weeber had died "last

night [September 27] after an illness of two days." Following "a long time studying the technical development of the automobile, Mr. Weeber in recent years devoted his energies to aeronautical engineering."¹⁰⁹³

The *Albany Evening News* recorded the passing of "Albany's only automobile manufacturer" who had refused "an offer to become technical adviser to Henry Ford" in favor of building cars in Albany.

For many years his name has been associated with the technical development of the automobile, engineers frequently visiting him for advice. In more recent years, he has devoted himself to aeronautic engineering at his laboratory and tool manufacturing plant at 170 Central Avenue.

A pioneer member of the Albany Auto Club and the Albany Automobile Dealers Association, Mr. Weeber also belonged to the Chamber of Commerce.¹⁰⁹⁴

John R. Carnell, who wrote to Marion soon after Christian's death, said he and Christian Weeber had been friends since they were "little schoolmates at Newtonville. I have always cherished [sic] Chris' friendship—Truthfully he was my first boyhood friend and continued such thru all the years since. That your father reciprocated my feeling has been a comfort and source of great pride

¹⁰⁹³September 29, 1932.

¹⁰⁹⁴September 29, 1932. It's unlikely, but one supposes not impossible, that Weeber declined to work for Henry Ford in favor of building cars in Albany. This would have been during the early 1900s, while any personal relationship more logically would have dated from 1906 or later with the sale of Ford cars by the C. F. Weeber Manufacturing Works. While in 1906 Weeber may have contemplated building more cars of his own, essentially he had given up manufacture to sell the products of other makers, the first being Maxwell and Ford. Perhaps Weeber was offered employment by the Ford Motor Company while he was a contracted Ford agent and distributor from 1906 to 1910. Or perhaps the newspaper's reference here actually is to Weeber's decision to abandon the sale of Ford cars in favor of Studebaker for the 1911 selling season. Any contact between Weeber and Henry Ford at best would have been fleeting. As has been demonstrated, most of Weeber's correspondence with the Ford Motor Company was with the New York Branch headed by Gaston Plantiff.

¹⁰⁹⁰See the directories for 1909, 1910 and 1911.

¹⁰⁹¹Marion Weeber to Geoffrey Stein in conversation, August 1987.

¹⁰⁹²September 29, 1932. The Weeber portrait was one taken about 1910. The *Times Union*, September 29, 1932, also printed a story of Weeber's career and passing.

to me.” Carnell continued by saying Weeber’s “loyalty, sincerity, generous kindness, were pure gold—never changing.” And “Chris has left us a wonderful example of integrity and industry, combining in his work inspiration and helpfulness for all who accepted his aid.”¹⁰⁹⁵



Unfortunately for the immediate surviving Weeber family, Christian Weeber had died owing mortgage payments on both his commercial property on Central Avenue and his house on Manning Boulevard. The debt meant that the family would have to move from their residence. In addition, the accumulated materials of over thirty years of invention and business had to be removed from the Central Avenue buildings as foreclosure took the buildings at 168 and 170-172.¹⁰⁹⁶ Ironically, the Weeber family’s misfortune over the course of many decades has proven to be of great benefit to the New York State Museum and its visitors, thanks to the generosity of Pauline, Gretchen and Marion Weeber.

Following Christian Weeber’s death, and with the need to vacate the C. F. Weeber Manufacturing Works property on Central Avenue, Pauline Weeber donated much from the material estate to the New York State Museum.¹⁰⁹⁷ Charles C. Adams, museum director, worked closely with the Weebers, especially Marion, whom he praised “for her care and devotion to the preservation of this material.”

The surviving complete Weeber car “and some parts” were received on October 10, 1933. The two model steam engines reached the Museum from

Pratt Institute on June 18, 1934, and on November 19, 1935, “engines” were delivered to the institution. Adams said he appreciated “the efforts which you two have made to assist us in this matter, and your willingness to furnish us with the documentary materials relating to Mr. Weeber’s inventions.”¹⁰⁹⁸

Marion Weeber appeared at the museum in March 1933, “to follow up information brought to me [director Charles Adams] by Peter Nelson on March 5, 1933, about the Weeber automobile.” She brought with her a clipping from the *Albany Evening News* about the Weeber car. She described the other “automobile materials and records” at the C. F. Weeber Manufacturing Works, 168 Central Avenue. . . telephone 30460.”

The Weeber car was transported by the Country Club Garage on the Western Turnpike for \$3.00. In a memorandum on August 1, 1933, Adams directed that the car be taken to the “Museum Lecture Room for a historic exhibit.” In pencil he subsequently noted, “Conf. Order Sept. 26, 1933;” “October 10, 1933, Auto delivered to Mus. CCA;” and “Auto put in His. Room Nov. 9 1933, CCA.”¹⁰⁹⁹ Marion Weeber recalled that the car “was towed down to the warehouse.”¹¹⁰⁰

Adams quickly followed the delivery of the car to the Museum with directions to pick up. . .

2 loads of the Weeber historic materials from 168 Central Avenue. . . This is the remainder of the automobile and mechanical equipment presented by the Weeber family. All of this can be delivered to Room 5 in the basement. I will supervise the delivery of the material and explain the plans to Mr. Staley.¹¹⁰¹

Marion Weeber’s work in ordering the Weeber materials is documented further in a State Museum memorandum that said, “This collection is all tagged and marked.” The reference is to the last batch of Weeber relics, which in November 1935 needed to be removed as soon as possible because of remodeling of “168-170 Central Ave. . . . Dr. Adams will have to hire a truck for the material.”¹¹⁰² On November 15, 1935, Adams directed

¹⁰⁹⁵Carnell to Marion Weeber from Lake Placid, October 1, 1932. On a photocopy of the original letter, she has noted “Carnell of Albany Business College.” On June 17, 1971, Marion Weeber wrote to Susan Kirkpatrick at the New York State Museum. “One of his best friends as John Carnell and his brother Prentiss of the Albany Business College. John and Chris were about the same age and neighbors in Loudonville. John was his confidant and helped test some of the automotive improvements, on his car.”

¹⁰⁹⁶Marion Weeber to Geoffrey Stein in conversation, August 1987.

¹⁰⁹⁷Gretchen Weeber to Geoffrey Stein, July 24, 1970, wrote, “The car and other items were donated by my Mother, following my Father’s death in September 1932.” Marion Weeber to Geoffrey Stein, August 24, 1970, wrote the “Chris Weeber Collection (which includes the 1898 Weebermobile)” was given “to the N.Y. State Museum by our late Mother, Mrs. Pauline P. Weeber, for their permanent collection.”

¹⁰⁹⁸Adams to Pauline Weeber, November 20, 1935.

¹⁰⁹⁹Adams to “Doctor Cheney,” August 1, 1933.

¹¹⁰⁰Marion Weeber Welsh to Geoffrey N. Stein, May 30, 1972.

¹¹⁰¹Adams to “Doctors Harlan H. Horner and Lloyd L. Cheney,” “Authorization of Drayage by Staley,” memorandum dated November 1, 1933.

¹¹⁰²Marion E. Bollman to “Mr. Whitney,” November 8, 1935.

Mr. Cheney to “authorize Mr. Staley to bring to the Museum the Weeber automobile materials from 168 Central Avenue. I will have to accompany him and make an appointment in order to secure the materials. This is very valuable material and largely metal.” Adams subsequently noted in pencil on his copy of the memorandum, “Weeber materials delivered to Museum—the remainder of the objects. CCA.”¹¹⁰³

Marion Weeber used standard New York State Museum tags in labeling her father’s material. In her hand surviving tags read with such notations as “3-A wooden chassis Christian F. Weeber (early experimental model)” and “2-E Gear Assembly Weebermobile model (experimental).” On many such tags, museum personnel crossed out the numbering system and inserted the four digit numbers in the museum’s sequential overall accession number system for the history collection. In the examples given, the new numbers were 2753 and 2763. In the 1970s, the museum instituted a new system utilizing three (and sometimes four) part numbers, the first part of which indicated the year of acquisition. All the Weeber items received in the 1930s were assigned catalogue numbers beginning with 1933. The two examples above became H-1933.6.5 and H-1933.6.50 A-B. In the interest of accuracy, the items received in 1934 (the two steam engine models) and 1935 (both of the examples here) might be renumbered again to reflect their receipts in 1935 rather than in 1933.

That Charles Adams recognized the value of the Weeber acquisitions is suggested by a letter he wrote to an acquaintance, Sanford L. Cluett, in March 1933. Taking note of the donation of “the first automobile ever made in Albany by C. F. Weeber” as well as “other valuable industrial history material with it,” Adams told Cluett he wished to speak to him about the donation which “looks like a rare gift and we should make the most of it.” Adams indicated the Museum needed “the technical advice of an engineer, and I hope that you will be able to aid the Museum in this way. We will be completely stalled in developing the industrial collections unless we can find some way to get more storage room, and I do not believe the industries of the State will be passive and see this phase

neglected when they realize what this means.”¹¹⁰⁴ Whether Cluett responded to Adams’ request is unknown here.

A lathe used by Christian Weeber in his Central Avenue facility was acquired in the 1930s by Robert E. Sumner, an automobile repairman. His business was later taken over by his son, Herman Sumner, who had worked with him in the 1930s. Herman said his father and another man purchased the R. K. LeBlond Machine Tool Company lathe, shafting and motor from the Weeber facility on Central Avenue and took the equipment to 465 Jay Street.

When the electric utility switched to 60 cycle current, the 40 cycle motor was rebuilt unsuccessfully and was replaced by the Sumners with a different motor. When Herman retired, he contacted the State Museum offering the lathe as a donation. The museum was pleased to add the lathe, the line shafting and even the box used to catch turnings from Christian Weeber’s shop, to its holdings in 1975.¹¹⁰⁵

When she learned that the lathe had gone to the State Museum, Marion Weeber wrote:

My mother, Pauline Weeber was administrator of the [C. F. Weeber] Estate and I and a man cousin were at the machine shop for about six months, cleaning it out, and selling what machinery and tools we could. Our lawyer advised this, so the property could be rented or sold.

At this time, Mr. Charles C. Adams, director of the N.Y. State Museum, was in and made a selection.

About three pieces of machinery were sold including the Lathe. The unsold machinery was sold with the building purchased by our tenant of the ground floor-Hudson Valley Asbestos Corp. There were partners, a Mr. Purcell, pres. and Mr. LaRoe. (I note that they are now [1972] at 20 Railroad Ave.)

The Machine Shop as I knew it was the second floor of the red brick building facing Central Avenue (170-172). It was of very heavy raw wood beam construction with thick flooring, brick walls and windows to north and south. It was run by electric with open leather

¹¹⁰³Adams to Cheney, November 15, 1935.

¹¹⁰⁴Adams to Cluett, March 31, 1933. Cluett was associated with Cluett, Peabody and Company, Inc., in Troy.

¹¹⁰⁵The replacement motor was not acquired by the Museum.

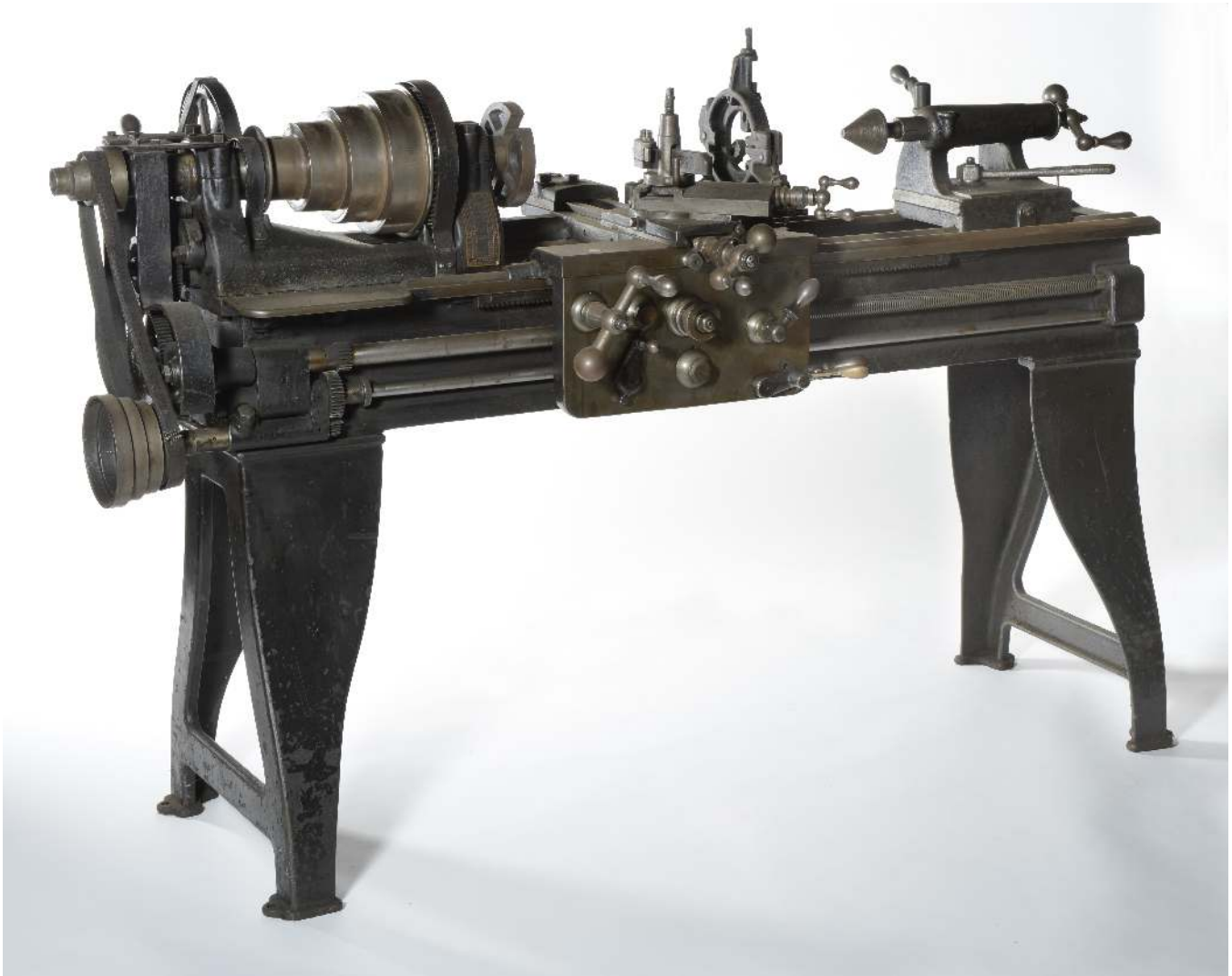

Figure 17.1: The LeBlond Machine Tool Company, 12-inch lathe used for many years by Christian Weeber. Subsequently operated by the Summer Auto Repair Shop in Albany, the lathe was a gift to the New York State Museum by Herman Sumner in 1975. NYSM Collection, H-1975.155.1.

belts overhead. There was also a loft where material and parts were stored and two small partitioned rooms, one for drafting and one for storage. These rooms were kept locked. At times there were several machinists working, but from 1929 on, Chris worked there alone. The entrance to this Shop was through the office located in the neighboring brownstone (168 Central Avenue). Chris bought this brownstone as a buffer between the shop and the church property. It was used for storage battery service, office and storage, and the wall was broken through at 2 levels to connect the buildings.

Originally in 1905-1907 and to about 1922-23 (see photo) the main floor facing Central Avenue, was the Auto Showroom, and the rear of the building on ground floor was the auto Repair & Machine Shop, which housed the Lathe, big punch presses and other machinery and welding equipment. The ground floor ran about 100 ft. beyond the two story front building and had an open yard for car repair which ran through to Bradford Street. About 1922-23 when he discontinued auto sales and service, he rented the main floor through to Kelly Springfield Tire Co., and move the machinery to the second floor.

The Lathe was also used at the factory and repair shop at 255 Sherman St. in 1902-1905. (See Photo).

I do not know whether he had it at 147 Central Avenue in the Bicycle Repair Shop or not in 1895. You may be able to ascertain the age of the lathe by markings on it.

He used the Lathe in the tooling of parts for his models and inventions. On it he also made the tools that formed parts in the manufacture of his inventions, the tire chain hook and others. It was also used to turn out special parts needed in early car repairs I remember the piles of both brass and steel dust and shavings under it.

It was very thoughtful of Mr. Sumner to offer the Lathe for the collection.

Marion Weeber appended her note with a correction. "Machine shop was ground floor to rear with repair shop *not upstairs*."¹¹⁰⁶

In 1987, Robert Preston, in Albany, advertised a "power hacksaw: CA1898, used by Christian Wee-

¹¹⁰⁶Marion Weeber Welsh to Geoffrey N. Stein, June 14, 1972. The photos to which Marion Weeber referred she added were "in your possession, not inclosed." The author is not aware of a picture in the Museum's holdings of the of the Sherman Street facility now (2006) demolished.

ver [sic] to produce Weevermobile in Albany in 1800s \$350."¹¹⁰⁷ While Preston had donated other, non-Weeber material earlier, he said he was too poor to take any less than his asking price and the hacksaw was not acquired by the Museum, whose "funds are depleted for the fiscal year." Geoffrey Stein wrote to Marion Weeber that he had asked Preston to let him know "where the saw goes."¹¹⁰⁸

Exhibits

The Weeber collection was noted in Charles C. Adams' "Twenty-Eighth Report of the Director of the Division of Science and State Museum," appearing with a photograph of Christian Weeber seated in his surviving car, in the May 1935 *New York State Museum Bulletin*. Adams said:

An outstanding historic acquisition has been that of the Weeber Automobile Collection, presented by Mrs. Pauline P. Weeber, Albany, N.Y. Of this collection the outstanding object of interest is an automobile...designed and built by her husband...This is probably the only automobile ever built in Albany. This material makes an excellent nucleus about which to build a collection of distinctly New York State historical objects which bear directly on the automobile industry.¹¹⁰⁹

The complete Weeber car was exhibited in the Witter Memorial Agricultural Museum at the State Fairgrounds in the 1950s. While the Witter hoped to have the car removed before the Fair opened in August 1957,¹¹¹⁰ it was apparently a year later before the transport to Albany took place.¹¹¹¹ Marion Weeber recalled the car "was displayed at the N.Y. State Exposition in Syracuse about 1961. Friends wrote us about seeing it." She also noted that "it

¹¹⁰⁷*Want Ad Digest*, February 1987.

¹¹⁰⁸Stein to Marion Weeber, February 25, 1987.

¹¹⁰⁹The *Bulletin* appeared as Number 304 in May 1935.

¹¹¹⁰M. G. McPherson, acting superintendent of the Witter Memorial Museum, to "Dr. [William] Fenton," New York State Museum, August 10, 1957. "We would like to have this exhibit recalled and moved back to Albany. If possible we would like to have this done before the opening of the Fair, Aug. 30th, as we are planning other use for the space."

¹¹¹¹Albert B. Corey, state historian, to N. F. Ronan, Superintendent of Operations and Maintenance, July 29, 1958. Corey asked, "Will you please provide a large truck to move an antique Weeber automobile from the State Fairgrounds in Syracuse to 1260 Broadway, Albany?...Since it is glaringly inappropriate to the agricultural exhibits at the Fair, it should be removed to Albany immediately."

was displayed for a time at the State Exhibit space on Broadway [in Albany]. Friends visited it there and told us that children were playing in it and tooting the horn."¹¹¹²

After Pauline Paul Weeber's death, "some photos and data were shown to Mr. Lassitor [sic], Director [sic] in December 1963..." wrote Marion Weeber a few years later. She noted, "I also had correspondence with Mr. Eugene F. Kramer, Senior Historian, Nov. 1966, but never got the Weeber Memorabilia together to show."¹¹¹³

In December 1963, the auto was moved from the museum's storage facility at 1260 Broadway to Morgan Hall, an exhibit gallery at the State Museum location in the Education Building on Washington Avenue in Albany. Curator Eugene Kramer noted that the museum planned "an extensive exhibit...based on the history of transportation in New York State." He observed that the car had been "In History Hall at one time prior to being moved to Broadway," so that he understood the car would fit into an available elevator. A mover, identified as "Berbrick," [who] transported the car for \$140 no problem in moving."¹¹¹⁴ A story in the Albany *Knickerbocker News* also mentioned the coming display with the Weebermobile becoming "the focus of a transportation exhibit" after having been in storage "for 30 years." The show was to open "'at a definite future date'" and also was to have models of the first train in New York State, the Clermont and a Concord stagecoach.¹¹¹⁵

Apparently, the transportation exhibit never opened and the Weeber car remained in Morgan Hall being used as a storage facility. In subsequent years, the vehicle was warehoused in rented space at the Rotterdam Industrial Park.

In 1970, the partially dismantled car was freshened in the museum shops at 60 Commerce Avenue, Albany. Curtis Fretz, of the museum's restoration shop, received the automobile in mid-January and worked into the spring. Early on he

"Removed 1½ qts. Gasoline Belived [sic] to be 40 Years Old."

Other work included degreasing and painting the frame; disassembling the engine; refitting bearings; disassembling and cleaning the rear end; welding and repainting the wrinkled fenders; polishing and lacquering the brass parts; repairing a steering wheel found in the Weeber collection but not attached to the car when he started work; filling cracks in the body (but preserving the original paint); and fitting new tires, among other tasks. The engine was started.¹¹¹⁶

In 1984, a replacement, self-generating but non-functional acetylene reproduction headlamp was acquired.¹¹¹⁷

The museum publicized Christian Weeber's life in an article appearing in its own journal, *Naho*, a magazine intended for a general audience. The present author's "Christian Weeber and his Weebermobile" appeared in the spring 1972 issue.¹¹¹⁸

In 1972, Grace O'Connor, in the Albany *Times Union*, wrote a full-page article entitled, "Weebermobile: It all Began With Bicycles." O'Connor quoted Geoffrey Stein about the renovation of the Weeber car. "By and large we did little but make the artifact more beautiful... We refurbished it, conserving rather than restoring it." O'Connor noted the "bounty of memorabilia of Weeber's 35-year automotive career donated by his family as well as through correspondence Stein developed with the inventor's two daughters... Gretchen and Marion." After tracing Weeber's career for the benefit of her readers, O'Connor concluded by writing of the new State Museum facility where"

Stein will have his opportunity to present a demonstration—of how a dedicated historian can start with one automobile from the late 1800s and build a complete exhibit around it which will tell the full story of one of New York's' greatest inventors and promoters of the automobile industry—Christian F. Weeber.¹¹¹⁹

¹¹¹²Marion Weeber Welsh to Geoffrey N. Stein, May 30, 1972.

¹¹¹³Marion Weeber to Geoffrey Stein, August 24, 1970.

¹¹¹⁴Kramer to Richard H. Davis, Building Superintendent, August 12, 1963. Kramer on one copy of the memorandum made notes on the progress of the move, which took place on August 23, 1963.

¹¹¹⁵Patricia Money, "State to Roll Out 1898 Weebermobile," *Knickerbocker News*, August 23, 1963. The models mentioned in the article were commissioned by the Museum in the late 1940s and have been displayed from time to time.

¹¹¹⁶Fretz, a masterful craftsman, worked on the car. In the course of the process, he started the engine but the car was not driven. His notes were consulted and quoted here.

¹¹¹⁷The Autolyte style lamp was furnished at a cost of \$450 by Stuart Bauman of Whitehouse Station, New Jersey.

¹¹¹⁸Vol. 5, no. 1, pp. 3-5.

¹¹¹⁹May 7, 1972. The several exhibits that included Weeber material in the museum building that opened in 1976 are described in the text below.

In 1975, the State Museum considered taking the Weeber automobile to Syracuse for display at the State Fair in August. "However, since the affair is to be outdoors, the decision has been made to wait for an enclosed area before exhibiting it again."¹¹²⁰ In addition, the author wrote to Marion Weeber a few weeks earlier that when the new State Museum building was to open in July 1976, "There will not be a Weeber exhibit at that time. I have proposed such an exhibit, but there are no definite plans for one at present."¹¹²¹

Nevertheless, the Weeber automobile was displayed in the building lobby for the opening of the museum in the new facility, the Cultural Education Center, part of the Nelson A. Rockefeller Empire State Plaza, on July 1, 1976. Marion Weeber was present and posed sitting behind the wheel of the car. She subsequently wrote the author to thank the museum for "beautiful presentation of the Weebermobile, Gasoline Engine [Weeber stationary engine], Patent Certificate and Drafting Instruments. I will treasure the memory."¹¹²²

A few weeks earlier, on June 14, 1976, the Commissioner of Education held a press conference to mark the completion of the Cultural Education Center. As an attention-getter, it had been proposed that Commissioner Ewald B. Nyquist be driven up to the front of the building on the South Mall Plaza in the Weeber car. Objections to the plan were raised by Chief Curator John S. Still, Principal Curator John S. Watson and Associate Curator Geoffrey Stein. The last mentioned potential overheating of the engine and the brittle state of the upholstery. In the end, a fire engine from the museum's collection was used instead.

In 1979, the Albany *Knickerbocker News* published a photograph of museum employee Jan Christman seated in the "1902 Weber automobile, one of several antique cars now on display in a special exhibit at the State Museum complex in

Albany's South Mall."¹¹²³ The location was the museum's South Hall, a gallery area temporarily serving as storage for history collections with occasional curatorial-led tours.

Later that year, the Weeber car was to be included in an exhibit called "Treasure House." Organized by the Roberson Center for the Arts and Sciences in Binghamton, the show, featuring objects from 51 different museums in New York, first had a run at the Roberson to be followed by a three-month scheduled stop beginning October 15 at the State Museum.¹¹²⁴

In a New York State Museum exhibit in 1980, "New York in Motion," the Weeber car was in the fourth floor gallery space that featured artifacts of power generation and devices incorporating integral power sources such as automobile engines.

In November 1983, the Albany Institute of History and Art opened an "Inventors and Invention" exhibit that included the Weeber automobile among objects produced by inventors of the Upper Hudson Valley. The Albany Institute calendar for November and December featured a photo of the Weeber auto on the cover. The exhibit continued into 1984.

In 1990, the State Museum presented "Christian F. Weeber and the Weebermobiles" in the Cultural Education Center (Museum) lobby. The two incomplete cars joined the third Weeber automobile in a temporary exhibit with other artifacts and images from Christian Weeber's life. The component parts of the partial autos were assembled for the event. For example, the iron frame and wooden body of the later car were mated, while the wire suspension wheels were put on to the axles of the earlier machine. Some restoration work was also performed on the later car, including gluing split panels, straightening a reach, and attaching a lamp bracket. The individual pieces for both cars apparently had been stored separately since being received by the museum in 1935.

An exhibit called "Ways We Collect" in the museum's South Hall in late 1995 and 1996, included the Weeber automobile and a painting and table-

¹¹²⁰Geoffrey Stein to Marion Weeber, July 25, 1975. Christian Weeber was referenced in *Cars Made in Upstate New York* by James Bellamy (Squire Hill Publishing Company, 1989) and *Standard Catalog of American Cars, 1805-1942* by Beverly Rae Kimes and Henry Austin Clark, Jr. (Krause Publications, 1985).

¹¹²¹Geoffrey Stein to Marion Weeber, June 6, 1975.

¹¹²²Marion Weeber Welsh to Geoffrey N. Stein, July 7, 1976. She also wrote, "I had a wonderful afternoon at the Museum and it was great to talk with you again. . . . The whole Cultural and Educational Center is a thing of beauty."

¹¹²³February 1, 1979.

¹¹²⁴Rochester *Democrat and Chronicle*, October 12, 1979. The author does not recall the shipment of the Weeber car to Binghamton and has found no record of such a loan.



Figure 17.2: Photograph of Marion Weeber in the Weebermobile, July 1976. NYSM Collection, H-1991.10.NN.

ware designed by Marion Weeber. She attended the opening reception on December 7, 1995.¹¹²⁵

From 2002 to 2012 the Saratoga Automobile Museum displayed the complete Weeber car among a number of historical automobiles.

Final Observation

Three-quarters of a century after his death, Christian Weeber's life provides interest in his entwined but distinct accomplishments as an inventor and as an automotive entrepreneur. It may be these two facets of his life are somewhat contradictory and struck him that way. Perhaps this explains his apparent interest in the 1910 period in selling out his thriving automobile sales and repair operation. A decade later, he did turn from the automobile business to focus more intently on invention—the drive that had inspired his early years and remained the dominant pursuit for the rest of his life.

¹¹²⁵Marion Weeber wrote the author, August 8, 1996. "I must tell you the truth about that Reception [December 7, 1995]. My train was held for engine replacement at Poughkeepsie, and was an hour late, so I ate a chicken sandwich on the train, from which I got food poisoning. When I reached the hotel in Albany, I was deathly sick and dizzy. I almost phoned my regrets, but tried a late appearance anyway. I had to walk carefully and hang on to chairs and people to steady myself. I was very disorganized, and was still sick the following day for my Luncheon appointment with the Albany Institute officials. I was also late for that." In October 1997, the Albany Institute of History and Art opened a temporary exhibit of Marion Weeber's work, "Marion Weeber: Industrial Designer." Jewelry, tableware, candlesticks and other objects donated by Marion to the Institute comprised the show. Marion Weeber also donated similar material to the State Museum in 1986 and 1991.

BIBLIOGRAPHY

Primary Sources

Most of the present work is based on documents and artifacts that comprise the Weeber Collection at the New York State Museum. The individual items are described in the text or in the accompanying footnotes or both. Consequently, these records of Christian Weeber's life and work are not further explained here.

There are other independent sources of information, sometimes also mentioned in the text and notes, which provided essential information in the writing of this book. Specifically, Albany newspapers and automotive trade journals have been vital to seeing this book completed. The most important sources included the following:

*American Automobile, The
Albany Evening Journal
Albany Times Union
Argus, The
Automobile, The
Automobile and Motor Review, The
Automobile Dealer and Repairer
Automobile Review, The
Cycle and Automobile Trade Journal
Dealer and Repairman, The
Directories, city. Various Albany and other directories.
Knickerbocker Press
Record-Knickerbocker-Express
Horseless Age, The
Motor
Motor Way, The
Motor World*

Secondary Works

Bellamy, James F., *Cars Made in Upstate New York* (Red Creek: Squire Hill Publishing Company, 1989).¹¹²⁶

¹¹²⁶Two pages are devoted to Christian F. Weeber. Bellamy lists the years of production as "C. 1899-1905."

Dicke, Thomas S., *Franchising in America* (Chapel Hill: University of North Carolina Press, 1992).¹¹²⁷

Epstein, Ralph C., *The Automobile Industry – Its Economic and Commercial Development* (Chicago: A. W. Shaw Company, 1928).

Gelderman, Carol, *Henry Ford the Wayward Capitalist* (New York: The Dial Press, 1981).

Hewitt, Charles M., Jr., *Automobile Franchise Agreements* (Homewood, Illinois: Richard D. Irwin, Inc., 1956).

Kimes, Beverly Rae and Henry Austin Clark, Jr., *Standard Catalog of American Cars 1805-1942, third edition* (Iola, Wisconsin: Krause Publications, 1996).¹¹²⁸

Lacey, Robert, *Ford The Men and the Machine* (Boston: Little, Brown and Company, 1986).

Nevins, Allan, *Ford: The Times, the Man the Company* (New York: Charles Scribner's Sons, 1954).

Seltzer, Lawrence H., *A Financial History of the American Automobile Industry* (Cambridge, Massachusetts: Houghton Mifflin Company, 1928).

Stein, Geoffrey N., "Christian Weeber and His Weebermobile," *Naho* (vol. 5, no. 1, 1972).

_____, "The Weeber Collection at the New York State Museum," *Journal of the Society of Automotive Historians* (no. 201, 2002).

_____, "The Life and Times of an Early Ford dealer: Christian F. Weeber of Albany, New York," Judith E. Endelman ed., *The Model T Reconsidered Proceedings from the World of the Model T Conference* (Dearborn, Michigan: The Henry Ford, 2008).

¹¹²⁷A chapter, "From Agent to Dealer," is devoted to the early years of the Ford Motor Company.

¹¹²⁸Kimes et al. devote one paragraph and a photograph to Christian Weeber-built automobiles. The text apparently is based on the Stein *Naho* article. More importantly, the Kimes work provided Stein with a ready reference for most pre-World War II American automobile manufacturing enterprises.