

PART FOUR: The Birth of Radio Control

# MODEL BUILDER



WORLD'S MOST COMPLETE MODEL AIRCRAFT PUBLICATION

NOVEMBER 1988

ICD 08545

U.S.A. \$2.95

Canada \$3.95

volume 18, number 202

## CONSTRUCTION

### Simple Hand-Launch R/C Glider

### THE WHISP

### Peanut Scale

### EVANS VP-2



**HOT TIPS FOR BEGINNING MODELERS**

R. A. BERGMAN

# MAKE THE QUANTUM LEAP.

Quantum is Airtronics' world class PCM professional R/C series, offering the finest top of the line features available on any Airtronics R/C system.

This state of the art system is refined and engineered for superior flying. Advanced features allow you to preset and control all aspects of pattern

the flexibility to match your individual preferences and flying style.

The 8 Channel FM/PCM Narrow Band Quantum Series features Pulse Code Modulation, Plug-In RF Module, Electronic Trims, and Adjustable Length and Tension Sticks.

Quantum incorporates Cartridge-Style Plug-In NiCd

Elevator, Flap, and Spoiler Controls.

Quantum QM8P provides Two Snap Roll Adjustments, Idle Up, Low Travel Throttle Trim and Variable Pitch Control Adjustments, Rudder/Aileron and Rudder/Elevator Mixing.

Quantum utilizes a cartridge-style plug-in NiCd battery.

This advanced system also features Travel Adjustments on Elevator, Aileron, Rudder,

Throttle and Prop Pitch, Automatic Dual Rate Rudder, Exponential Adjustment on Ailerons, Elevator and Rudder, Preset Flap Trim, Trim Dual Rate, Retract and Landing Gear Brake System, and Mixture Control.

Quantum features an accessible, front-mounted control panel.

aircraft maneuvers and scale flight operations.

The Quantum QM8P gives you the competitive advantage of fully adaptable transmitter features, providing

#### QM8P SYSTEM SPECIFICATIONS:

Transmitter Type:	8 Channel Digital Proportional Narrow Band
Dimensions:	L: 7" x W: 2" x H: 7 1/2"
Weight:	40 oz.
Power Output:	750 MW
Frequencies:	50 and 72 MHz
Modulation:	FM/PCM
Power Supply:	9.6 Voh NiCd
Current Drain:	210 MA
Receiver Type:	Dual Conversion FM/PCM Narrow Band
Sensitivity:	1.5 Microvolts (nominal)
Power Supply:	4.8-6.0 Voh NiCd

Battery, L.E.D. Indicators, Low Battery L.E.D. Indicator and a Liquid

Crystal Display with Bar Graph Meter and Integrated Timer.

The innovative QM8P also features Servo Reversing, Dual Rate on Elevator, Triple Rate on Aileron, Fail/Safe with Inhibit, and Mix Functions for

One look will tell you this R/C system means business; from its clean professional appearance to its full array of advanced technological flying features.

When only the best is good enough, get the best radio you can buy. Make the quantum leap to Airtronics' Quantum.

 **AIRTRONICS** INC

11 Autry, Irvine, CA 92718 (714) 830-8769

Airtronics' complete new product catalog is available for \$2.00. Please send check or money order to the address above.

# New book "briefings" from H.A.



**BEECHCRAFT: STAGGERING TO STARSHIP.** Ed Phillips, Staggingwing, Twin Beech, Bonanza... every production and experimental Beech airplane ever flown is documented. Complete warbird coverage of UC-43, GB-1, AT-7, AT-11, C-45, the mighty XA-38 Grizzly. Postwar years including Model 35 Bonanza, Travel Air, military and export models, T-34 Mentors, Barons, Dukes and the legendary King Airs; they're all here plus much, much more. With 245 photos, including many never published before, 343-view drawings, technical specifications. 96 pages, 8 1/2" x 11", s/bd. .... 2012A \$14.95



**THE PIPER CLASSICS.** Christy. The fun "Cubs"—simple tube and fabric aircraft. Discusses the evolution of Piper lightplanes—J-3 Cub, J-4 Coupes, J-5 Cruiser, PA-11, PA-18, Vagabonds, Colts, Pacer/Tri-Pacer, even Wag-Aero's CUBy. Also covered: Availability, problems, SPECS, rebuilding, maintaining and operating. 101 illus. 160 pgs., 5" x 8", s/bd. .... 4208B \$13.95



**THE PIPER INDIANS.** Clarke. Gain practical insight into the reasons for the increasing popularity of the Piper Indians! A model-by-model inspection of the series: the original PA-28 Cherokees - the improved Indians; Warriors, Archer, Dakota - the retractables; PA-24 Comanches, PA-28R Arrows - the hard working sixes; and the Tomahawks, Apaches. Covers: where to find, maintenance, specs, refurbishing, and... all of those ADs and STCs and modifications. 112 photos, 288 pgs., 7" x 10", s/bd. .... 4213B \$16.95



**PACIFIC AIR RACE.** Scheppeler. Eight wood, wire and fabric planes took-off from Oakland, CA. Aug. 16, 1927... their destination, Honolulu; their goal, glory prize monies. Two of the eight made it. This is the true story of the pilots, mechanics and the bystanders. 66 b/w photos, 208 pgs., h/bd. .... 4353C \$24.95



**U.S. NAVY CARRIER BOMBERS OF WWII.** Profiles of the TBD Devastator, SBD Dauntless, SB2C Helldiver and TBF/TBM Avenger. Carrier operations, both routine and hazardous are depicted with excellent three-view drawings, color side-view and 121 photos and cockpit views. 120 pgs., 8 1/2" x 11", s/bd. .... 4103A \$9.95



**U.S. NAVY CARRIER FIGHTERS OF WWII.** A fine reference volume containing profiles on the Buffalo, Wildcat, Hellcat, Corsair and Bearcat. Lots of combat photos, cockpit and detail shots, plus high-quality three-view drawings. 153 photos, 51 color side and top-view paintings. 120 pgs., 8 1/2" x 11", s/bd. .... 4104A \$9.95



**WINGS OF CESSNA: MODEL 120 TO THE CITATION III.** Ed Phillips. The complete family of Cessna airplanes from the rag-wing 120 to the high-tech Citation III. Experimental ships, one-of-a-kind, the CH-1 helicopter and military models, every one documented with technical changes by model year, specs... performance, total built and serial number data. Much new info on the classic 170 and 190/195 models. 229 photos of airplanes and instrument panels plus more than 50 detailed 3-view drawings make this a valuable reference for the buff and modeler. 100 pgs., s/bd. .... 2011A \$12.95



**IN DETAIL & SCALE \$7.95 EACH**

F-4 Phantom II Part 1	1041B	B-29 Superfortress	1050B
B-17 Flying Fortress (PL 1)	1042B	B-17 Flying Fortress, Part 2	1051B
F-16 A & B Falcon	1043B	F-4 Phantom, Part 3	1052B
F-111 Aardvark	1044B	F-106 Delta Dart	1053B
F-5E & F Tiger II	1045B	F-15 Eagle	1054B
F-10 Hornet	1046B	F9F Panther	1055B
F-4 Phantom II Part 2	1047B	F9F Cougar	1056B
F-105 Thunderchief	1048B	F11F Tiger	1057B
F-14A Tomcat	1049B	A-10 Warthog	1059B
		F-101 Voodoo	1061B

**MODERN FIGHTING AIRCRAFT \$11.95 EACH**

F-15 Eagle	1301C	The Harrier	1305C
F-16 Falcon	1302C	A-10 Thunderbolt II	1306C
F111	1303C	F/A-18 Hornet	1307C
F-4 Phantom	1304C	F-14 Tomcat	1308C

**FROM THE GROUND UP.** Weick and Hansen. Autobiography of aeronautical engineer Fred Weick, designer of the Ecoupe, Ag-1 Piper Pawnee ag plane and the Piper Cherokee. Weick made a significant contribution to the advancement of aeronautical technology, including development of the steerable tricycle landing gear. Covers history of ERCO and the Ecoupe, development of the Ag-1 Pawnee and the Cherokees. 109 photos, drawings. 556 pgs., 6 1/2" x 9", h/bd. .... 4351C \$39.95

**FOKKER FIGHTERS OF WWI.** Imrie. From the genius of "the Flying Dutchman", Anthony Fokker, came the fighting machines that made heroes out of Immelmann and Boelcke and "Fokker fodder" out of many Allied aircraft. Great photos of the fragile Eindekkers, DR-1 Triplane, D.VII, EV parasols, and obscure types. 120 photos, 68 pgs., 7" x 9 1/2", s/bd. .... 4549C \$8.95

**THE AMERICAN FIGHTER.** Angelucci & Bowers. A definitive reference book on American fighters from 1917 to present, superbly chronicling every model and variant from WWI biplanes to the sophisticated war machine of today. 870 photos and 1340 schematic drawings, with performance specs and production history on every plane. 480 pgs., 8 1/2" x 11", h/bd. .... 3475C \$40.00



**SUPERFORTRESS: THE B-29 AND AMERICAN AIRPOWER.** by General Curtis LeMay and Bill Yenne. Here is the complete story of the B-29 as told by General LeMay who implemented its fighting strategies... from General Billy Mitchell's vision of the '20s for long range strategic bombing... the massive war effort that pushed the B-29 off the drawing boards and through the factory gates in record time and the strategic bombing of Japan and the atomic strikes. 34 pgs. of photos, 288 pgs., 6" x 9", h/bd. .... 3220D \$18.95

**CURTISS 1907-1947.** Bowers. Complete history of Glenn Curtiss and his companies. Model by model coverage with clear crisp factory photos, historical detail and full specs. Covers early experiments by Glenn Curtiss and exhibition tours. From early flying boats, June Bug, NC-4, Jenny, Hawk fighters and racers, Robin, Condor to the P-40s, C-46 and jet a/c. Hundreds of photos, 637 pgs., 5 1/2" x 8 1/2", h/bd. .... 3383C \$34.95

**TEST PILOTS** by Richard Hallion. The complete story of the men, their planes and accomplishments, from the pioneers of flight through the Golden Years to the first jet and the first man on the moon... from Jenny to Voyager, from Spitfire to Space Shuttle—and the technical breakthroughs they risked their lives to verify. Some stories end in tragedy, others in brilliant triumph, but each helped explore the frontiers of flight. Over 150 photos, pgs., 6" x 9", s/bd. June Release ..... 4352C \$17.50

**ONCE THEY WERE EAGLES.** Walton. The men of the Black Sheep Squadron, Corsairs vs Zeros, combat at its best. You'll fly the missions, party with the men, share their victories and heartaches, get to know "Pappy" Boyington. Nifty then-and-now portraits of the pilots. Going to be a classic, this well researched book is great combat writing with no minced words. Well illustrated. 214 pgs., 6" x 9", h/bd. A Reviewer's Choice ..... 2926C \$18.00

**PAN AM: AN AIRLINE AND ITS AIRCRAFT.** R.E.G. Davies. Pan Am's story spans the entire history of air transportation in the U.S., from float planes, to "China Clippers," to the jet age. Covers the history of the airline by focusing on acquisition of a new airplane or expansion of its air routes. 32 full color scale drawings by Mike Machat, 20 maps, 96 pgs., 11" x 8 1/2", h/bd. .... 3478C \$24.95

**TOP GUN.** Hall. Fly with the best fighter pilots in the world, in training at NAS Miramar at the Navy Fighter Weapons School. Ride with them at supersonic speeds as they hone their skills by maneuvering with and out-shooting aggressor aircraft. Witness their rivalries, egos, and camaraderie as they live life on the razor's edge. 144 pgs., 120 photos, 24 in full-color, s/bd., 8" x 8 1/2". .... 4436A \$12.95

**THE SMITHSONIAN BOOK OF FLIGHT.** Walter Boyne. A fresh look at aviation history going beyond a mere chronology of events. Boyne captures the drama of the development of flight as it really is, a deeply interrelated complex of men, machines and national priorities. 155 full-color photos, including a 12 page full-color gatefold, 130 b/w photos, 288 pgs., 9 1/2" x 10 1/2", h/bd. .... 3477 \$38.00

**AIR PORTFOLIOS—A full-color pictorial history of the World's most popular airliners and civil workhorses.** A spotter's guide to the colorful liveries of each operator of that aircraft. Extensive captions give historical perspective and interesting facts. Each book contains approximately 64 color photos in 64 pages. H/bd., 9 1/2" x 7 1/2".

**Vol. 1—Boeing 737 P.P.R.**  
Smith ..... 2391C \$8.95

**Vol. 2—Shorts 330 and 360.**  
Smith ..... 2392C \$8.95

**Vol. 3—Douglas DC-9 and MD-80.**  
Smith ..... 2393C \$8.95

**Vol. 4—Airbus A300 and 310.**  
Smith ..... 2394C \$8.95



## Dramatic New Videos!



**THE AIRSHOW.** The most spectacular performances of the US Blue Angels, Italian Freccia Tricolori, Canadian Snowbirds plus the Brazilian and French national aerobatic teams as they perform at the Canadian Abbotsford International Airshow. Take your seat in the cockpit of the world's fastest and sexiest aircraft as they swoop and soar wingtip to wingtip. Witness exhibitions of the Harrier, Tomcat, Hornet, Concorde and SR-71 Blackbird. 60 min. A REVIEWER'S CHOICE. VHS V8979N BETA B8980N only \$19.95

**ADVANTAGE HORNET.** Breath-taking footage puts you in the cockpit of the F/A-18 Hornet. Share the pilot's view of flight testing, aircraft carrier qualifications, air combat maneuvering, weapons delivery, mid-air refueling and heart-stopping low-level formation flying. Experience this remarkable machine from tree-top level to over 50,000 feet. See why the Hornet was chosen by the U.S. Navy's "Blue Angels." 60 min. VHS V8722D BETA B8723D \$59.95

**EAGLE COUNTRY.** You're there in the cockpit as you scramble after intruders trying to penetrate North America and Central European Airspace. Feel the "G" forces as you push the F-15 to its limits in spectacular air-to-air combat. Brief with F-15 pilots as they discuss tactics, missions and weapons. The F-15 Eagle is every fighter pilot's dream and every MIG pilot's nightmare. 60 min. VHS B8720D BETA B8721D \$69.95

**FIGHTER ACES OF WW II.** Return to 1943 with four Aces of the 357th FG. of the Mighty 8th, their own stories, their gun-camera-footage. Not a Hollywood re-creation, but "The Real Stuff." These are the pilots who changed the course of WWII as they escorted American bombers deep into enemy territory and stayed to challenge, and defeat, the best the Luftwaffe had to offer. 47 minutes. VHS B8714 was \$29.95—Now \$13.98

Pilot Manuals		JANE'S SERIES	
P-38	1401B \$6.95	Harrier, Sweetman	2374C \$10.95
P-39	1402B \$6.95	Phantom, Sweetman	2375C \$10.95
P-40	1403B \$6.95	Hercules Gaines	2381C \$12.95
P-47	1404B \$6.95		
P-61	1405B \$7.95		
P-63	1406B \$7.95		
F-82	1407B \$7.95		
B-17	1408B \$8.95		
B-24	1409B \$10.95		
B-25	1410B \$10.95		
B-26	1411B \$12.95		
F-4U	1412B \$7.95		
F-6F	1413B \$7.95		
FM-2	1414B \$10.95		
AT-6	1415B \$7.95		
Spitfire	1416B \$3.95		
Hurricane	1417B \$3.95		
Mosquito	1418B \$3.95		
Me262	1419B \$7.95		
F-80	1420B \$7.95		
B-29	1436B \$10.95		

# Historic Aviation

3850H CORONATION RD., EAGAN, MN 55122

Charge:  VISA  MasterCard  
Acct. No. \_\_\_\_\_  
Exp. Date \_\_\_\_\_

FREE CATALOG

Please Print Name \_\_\_\_\_  
Address \_\_\_\_\_  
City \_\_\_\_\_  
State \_\_\_\_\_ Zip \_\_\_\_\_

14 DAY MONEY BACK GUARANTEE

Send Items: \_\_\_\_\_ \$ Total for items

\$ 3.95 Handling Total Enc. U.S. Funds

Country \_\_\_\_\_



Call us Toll Free 800-225-5575

MN, AK, and foreign countries use 1-612-454-2493 (not toll free). Charge VISA or MasterCard. MN residents add 6% sales tax. Dealers invited. Authors manuscripts invited.

# MODEL BUILDER

NOVEMBER 1988

volume 18, number 202

898 West Sixteenth St., Newport Beach, California 92663 Phone (714) 645-8830

## CONTENTS

### FEATURES

WORKBENCH, <i>Bill Northrop</i> . . . . .	6
DEAR JAKE . . . . .	7
OVER THE COUNTER . . . . .	8
BIG BIRDS, <i>Al Alman</i> . . . . .	10
CHOPPER CHATTER, <i>Dick Grossman</i> . . . . .	12
ELECTRONICS CORNER, <i>Eloy Marez</i> . . . . .	16
HOW TO FLY PATTERN, <i>Dick Hanson</i> . . . . .	17
ELECTRIC POWER, <i>Mitch Poling</i> . . . . .	18
R/C GUFF, THE LIFE STORY, <i>Dr. Walt Good</i> . . . . .	20
SIMPLY SCALE, <i>Steve Gray</i> . . . . .	24
PLUG SPARKS, <i>John Pond</i> . . . . .	26
ALL ABOUT ARFS, <i>Dr. Art Steinberg</i> . . . . .	32
MODEL DESIGN & TECHNICAL STUFF, <i>Francis Reynolds</i> . . . . .	34
R/C SOARING, <i>Bill Forrey</i> . . . . .	35
INSIDE ENGINES, <i>Stu Richmond</i> . . . . .	40
HEY KID, <i>Bill Warner</i> . . . . .	42
INSIDERS, <i>Dave Linstrum</i> . . . . .	48
HANNAN'S HANGAR, <i>Bill Hannan</i> . . . . .	50
FREE FLIGHT, <i>Bob Stalick</i> . . . . .	56
CONTROL LINE, <i>John Thompson</i> . . . . .	60
RAMBLIN' IN AUSTRALIA, <i>Stu Richmond</i> . . . . .	62

### CONSTRUCTION

THE WHISP, <i>James Tank</i> . . . . .	14
CLASSY CLASS "C" GLIDER, <i>Joe Weathers</i> . . . . .	31
EVANS VP-2 PEANUT, <i>Walt Mooney</i> . . . . .	52

COVER: The Gee Bee Model Z "City of Springfield" was the first of the unlimited racing planes designed and built by the Granville Brothers. Powered by a P&W Wasp Jr. engine producing 535 hp, the Model Z dominated the 1930 National Air Races. The only serious competition the Z faced in the Thompson Trophy Race was the Laird Super Solution, which had days before won the Bendix Trophy piloted by Jimmy Doolittle. No one will ever know how the race might have turned out had mechanical problems intervened, as the two airplanes were closely matched. As it happened, the Laird began to show smoke early in the race and had to drop out with a failing engine. The Gee Bee performed to perfection and swept the field with the remaining challengers to win the 1930 Thompson race at an average speed of 236.2 mph. Shortly thereafter, the Model Z was destroyed while being piloted by Lowell Bayles, who had flown her to the Thompson victory, in an attempt at the landplane speed record. This original 22 x 36 acrylic painting is available for purchase. In addition, collector prints of this and all the past and future race plane cover paintings appearing in *Model Builder* are available from Robert A. Benjamin Aviation Art, 1222-26th Ave. N.E., Olympia, Washington 98506; (206)352-2602. Please call or write for a free illustrated print catalog.

### STAFF

**EDITOR/PUBLISHER**  
Wm. C. Northrop, Jr.

**GENERAL MANAGER**  
Anita Northrop

**ASSISTANT GENERAL MANAGER**  
Dawn Johnson

**MANAGING EDITOR**  
Richard Dowdy

**PRODUCTION ARTIST**  
Kimber Jett-Baird

**DRAWINGS BY**  
Al Novotnik

**ACCOUNTING MANAGER**  
Robert Ruiz

**SUBSCRIPTION MANAGER**  
Audrey Peterson

### CONTRIBUTING EDITORS

Al Alman	Walt Mooney
Jake Doe	Mitch Poling
Bill Forrey	John Pond
Steve Gray	Fernando Ramos
Dick Grossman	Francis Reynolds
Bill Hannan	Stu Richmond
Dick Hanson	Bob Stalick
Cees Kaijim	Art Steinberg
Dave Linstrum	Cliff Tacie
Fred Lehmborg	John Thompson
Eloy Marez	Bill Warner

### ADVERTISING

Gordon Boudewyn  
Advertising Accounts Manager  
Corporate Office  
(619) 744-7337

Al Novotnik  
4 Beverly Pl., Norwalk, CT 06850  
Bus. Phone (203) 847-7478

MODEL BUILDER (ISSN 0194 7079) is published monthly by RCMB INC., 898 West 16th St., Newport Beach, California 92663. Phone (714) 645-8830.

Subscriptions: \$25.00 per year, \$47.00 for two years. Single copies \$2.95. Subscriptions outside the US (except APO & FPO) \$38.00 for one year only. All payments must be in US funds, drawn on a US bank. Copyright 1988 by RCMB INC. All rights reserved. Reproduction without permission prohibited.

Change of address notices must be received six weeks before date of issue that new address takes effect. Send old address with new . . . old label preferred. Duplicate issues cannot be sent. Postmaster send address changes to Model Builder, 898 W. 16th St., Newport Beach, California 92663. Second class postage paid at Newport Beach, California, and additional offices.

# WE PUT THE FUN BACK IN FOUR WHEEL DRIVE!

We are proud to introduce a breakthrough in competition ready four wheel drive cars.

The Mercury Xi-4™.

This truly affordable 1/10 scale four wheel drive radio control car comes in ready to assemble kit form. It has many 'trick' features which give it a distinct advantage in competition racing.

Great strength and low center of gravity have been designed into the shielded monocoque ABS resin frame. The body and rear wing are molded from durable

polycarbonate resins to withstand punishment. All radio, battery and drive train components are protected. Due to the high speeds and torques involved, the steering servo is protected by a triple-save servo saver.

The gear drive system consists of fully assembled front and rear differentials, plus a center differential with a motor protecting adjustable clutch/torque limiter. Drive power comes

from a RS-540 motor and is transferred via dual lightweight toothed belts which provide instant acceleration with minimum power loss. Belt maintenance and tension is simple due to several access hatches located along the drive train. Power is put to the ground through the durable low-profile pin spike tires. The tires are mounted on

**QuikChange™** lightweight one piece chromed wheels for easy maintenance.

The suspension is superbly handled by a 4 wheel independent wishbone system. This system has adjustments for wheel camber and toe-in as well as shock tension and wheel travel. Four universal 'dogbone' drive shafts relay full driving power to all wheels for perfect traction.

# M E R C U R Y

## Xi-4™

### TECHNICAL SPECIFICATIONS:

- Overall length: 13.78 inches (350mm.)
- Overall width: 9.61 inches (244mm.)
- Overall height: 6.19 inches (157mm.)
- Average total weight: 56.44 ounces (1600g.)
- Wheel base: 10.63 inches (270mm.)



The Mercury Xi-4 requires a 2 channel radio equipped and a 7.2VDC NiCd rechargeable battery pack to operate. (not included)



## WORLD ENGINES INC.

8960 Rossash Road, Cincinnati, Oh, 45236  
Phone: (513) 793-5900 • Telex: 214 557

These products are available exclusively through World Engines' dealers nationwide.

Mercury Xi-4 is a trademark of World Engines Inc.



## FOR A "SUPER" FINISH ON YOUR MODEL, TRY SIG SUPERCOAT IRON-ON PLASTIC COVERING AND SUPERTRIM SELF-ADHESIVE TRIM ROLLS



Supercoat being applied to a balsa wing



SIG molded foam wing covered with white Supercoat and decorated with SuperTrim.

More and more modelers are turning to Sig Supercoat for fast and easy finishes on their new models. Its light weight, low cost, and great strength make Supercoat an attractive alternative to the standard high cost iron-on films. SuperTrim rolls are the perfect companion to Supercoat. Use SuperTrim to add stripes, sunbursts, checkerboards, lettering and insignias to your model the easy way. Simply cut out, peel off, and stick-on! Both Supercoat and SuperTrim are totally fuel proof and both come in colors to match our popular Supercoat Dope.

### SUPERCOAT

#### PLASTIC COVERING MATERIAL

- \* SCC-410 Waco Red
- \* SCC-411 Fokker Red
- \* SCC-412 White
- \* SCC-413 Dark Blue
- \* SCC-414 Sky Blue
- \* SCC-415 Medium Blue
- \* SCC-416 Dark Orange
- \* SCC-420 Silver
- \* SCC-418 Cub Yellow
- \* SCC-419 Black
- \* SCC-425 Midnight Blue
- \* SCC-421 Transparent Red
- \* SCC-422 Transparent Yellow
- \* SCC-423 Transparent Blue
- \* SCC-424 Transparent Orange
- \* SCC-417 Antique (Semi-Transparent)

### SUPERTRIM

#### SELF-ADHESIVE TRIM ROLLS

- \* SCT-510 Waco Red
- \* SCT-511 Fokker Red
- \* SCT-512 White
- \* SCT-513 Dark Blue
- \* SCT-514 Sky Blue
- \* SCT-515 Medium Blue
- \* SCT-516 Dark Orange
- \* SCT-520 Silver
- \* SCT-518 Cub Yellow
- \* SCT-519 Black
- \* SCT-525 Midnight Blue
- \* SCT-526 Metallic Blue
- \* SCT-527 Metallic Red
- \* SCT-528 Metallic Gold

\* THESE COLORS MATCH SIG SUPERCOAT DOPE.

**Super Fast** - Less time in the workshop, more time flying.  
**Super Tough** - Resists punctures and scratches.  
**Super Clean** - No messy paints or fumes.

See your dealer first! If not available, call 800-247-5008 toll free for orders only. For domestic orders under \$15 add \$2.50 postage. Over \$15 ppd. Catalog 50 - \$3.00



**SIG MANUFACTURING CO., INC. . . . . Montezuma, IA 50171**



# Performance Blended Fuels

## Just Imagine . . .

- Higher Performance and Cooler Operation Without Burning Higher Nitro!
- Total Lubrication Protection Without an After-Run Oil!
- Smooth, Reliable Transition to Full Throttle and Back to Idle Without the Engine Quitting!
- Castor Protection Without Carbon Buildup!
- Consistent Runs, Gallon After Gallon, Without Constant Needle Valve Adjustments!
- All Quality Blended in the Most Modern, Most State-of-the-Art Facilities in the World!

Well, you don't have to leave it up to your imagination anymore. You can now run a full range of **BYRON ORIGINALS PERFORMANCE BLENDED FUELS**.

Byron Originals fuels have been researched extensively to provide the best of all desired qualities in a fuel. Our first testing was to meet the stringent demands of today's high performance ducted fan engines. Our subsequent testing has proven, regardless of whether you fly sport, pattern, helicopters, or are into boats or cars, your engines deserve the same type of top performance potential and uncompromising lubrication protection of our Performance Blends! We feel, as you do, that regardless of the level of your investment and involvement in R/C, all your engines deserve as much protection as is available.

Each and every supplier of raw materials has been hand selected to become more of a partner with us in the fuel business than a mere supplier. As a result, only the finest quality methanol, nitromethane and lubricants are shipped to our blending facilities. But this is just a start. The freshness of the methanol and nitromethane are guaranteed during our storage with a special nitrogen gas displacement system that continually protects these materials from moisture contamination . . . the fuel you receive is as fresh as the day the raw materials were delivered to us.

### Synthetic or Synthetic/Castor Blend . . . It's Your Choice

Byron Originals Fuels are available in both a Synthetic/Castor Blend and a total Synthetic, each in various nitromethane levels to suit your individual needs and the needs of your engines. And each blend provides top performance and maximum protection in all types of engines.

### Byron Originals Modified Castor . . . Unlike Any Other

With our Synthetic/Castor Blend, you can have your cake and eat it too! No other castor treats your engine to all the high temperature lubrication, boundary and shearing protection (available only from castor oil) without the carboning and varnish build-up normally accompanying a castor blend.

### Extreme Pressure Lubrication and Anti-Corrosion Additives Make the Byron Synthetic a Safer Fuel to Run

Our Synthetic is custom blended to our specifications to provide not only the load-bearing capacities of castor, but to provide effective and long-lasting corrosion protection . . . something rarely provided by Synthetic Lubricants!

### Computerized Blending Facilities Assure Consistent Blends

One of the biggest complaints of modelers, regardless of engine type, is the unavailability of a consistent blend, gallon after gallon. That's why we worked just as hard on designing our state-of-the-art blending facilities as we did on the fuel formulas themselves. Our computerized metering systems guarantee the same accurate blend, regardless of temperature fluctuation. That means you can rely on freshly blended fuels, season in and season out.



See your local dealer  
or order direct:

**Byron Originals, Inc. • P.O. Box 279 • Ida Grove, IA 51445**

**Dealer Inquires: Phone (712) 364-3165**

**Fuel Orders Only: Phone (712) 364-2009**

Item	Order No. (per case)	Retail (Per Gal.)	Factory Price* Per Gallon (1 to 4 Cases)	Factory Price* Per Gallon (5 to 10 Cases)
Byro-Jet 5% Nitro	3130005	\$10.95	\$ 7.50	\$ 7.00
Byro-Jet 10% Nitro	3130010	\$12.95	\$ 8.50	\$ 8.00
Byro-Jet 20% Nitro	3130020	\$17.50	\$12.00	\$11.25

\*All prices include shipping within the 48 contiguous United States. Alaska, Hawaii and Overseas, call for shipping quote. Prices subject to change without notice. Fuel available in case lots only. Minimum order, 1 case.



## from Bill Northrop's workbench

• **BOMB** There's a word with several connotations, the most obvious being an explosive device. It also relates to the fate of a comedian who has either bad timing, lousy writers, poor delivery, the wrong jokes for the particular audience, or all of the above... the **BOMBS!**

About 20 some years ago, this writer came up with another connotation, about which he wrote an article that was published in another model magazine... before *Model Builder* was born. Taking the letters in the word as initials... B.O.M.B., we wrote about the Builder of the Model Business. Come to think of it, you could say this meaning is also somewhat "explosive," though considerably moreso in these times than it was 20 years ago.

We're not exactly sure when the Builder of the Model rule was first established, but we do know what its purpose was then. It was in the days before R/C became the largest and most dominating facet of the model aircraft hobby, and its primary purpose was to prevent the use, in AMA-regulated competition, of "Daddy-built" models by Junior contestants. Many of today's Open and or Senior Citizen modelers who flew in competition back in the pre-R/C days can remember low-teen and pre-teen youngsters appearing at contests with models they couldn't possibly have built without 50 to 100 percent "help" from their modeler father or big brother. And when it came time to fly, maybe Junior was allowed to hold the model while big brother or the father started the engine and adjusted the needle. Then it was, "Hold it here, and there, aim it toward that smokestack, point the nose up... more... dontgetcherfingerinthepropitmightstoptheengine... now throw it!" Hey, don't get us wrong... there's nothing in the world better than getting our youngsters involved in this great hobby... in fact there's not enough of it going on, particularly in recent years... but Juniors and/or beginners of all ages should

step into the competition ring on their own. For every beginning modeler who has experienced help in learning about the hobby, there are many others who have to learn by doing, and by watching others, and by asking questions, and by purchasing their own model supplies, and most of all, *building their own models*. The B.O.M. rule was intended to put every contestant on an even footing and let their own building and flying skills get them to the top.

Then... along came R/C... but don't get the idea we're trying to make R/C the villain in this discussion. For many of its early years, radio control aircraft modeling was merely an extension or offshoot of both free flight and control line. All of the development was accomplished by dedicated, pioneering model designers and builders, some working with electronics specialists, others learning the basics of electronics on their own. During this developmental period in radio control, competition was limited to one area... aerobatics, or stunt, or precision pattern, or just "pattern" for short. This was when it was still a novelty to be able to stand on the ground and make your airplane do all sorts of funny things in the sky, without cables or any other visible means of contact. Magic!

Eventually, scale models began to appear, mostly carefully chosen designs selected for their inherent stability. Then came gliders, and then pylon racers, and then superregenerative receivers, which allowed more than one airplane to be flown at a time. Wow! Throughout all of this development period, the Builder of the Model rule continued, pretty much unchallenged, as many models were still being originally designed and scratch-built by the advanced modelers, while others were building from kits that required extensive modeling skills and the capability of making continual crash repairs!

As the aircraft designs became more dependable, and the radio systems more reliable and requiring less knowledge of electronics to operate successfully, the R/C hobby was also becoming more visible to the non-modeling public. Subsequently, the R/C model industry recognized an in-

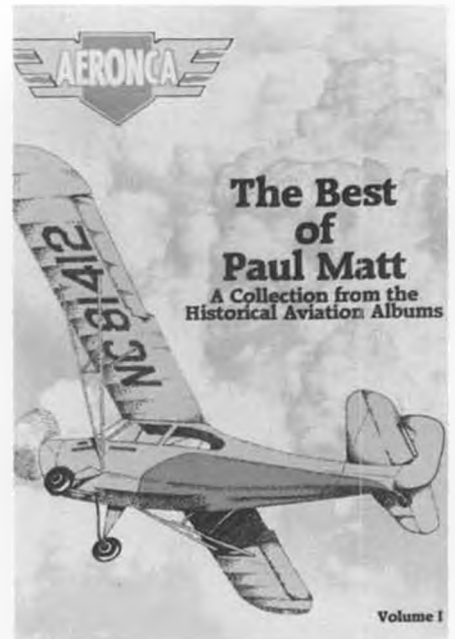

creasing demand from non-modelers... as well as modelers who did not have the time and/or the building skills to create their own models... for increased prefabrication in the kits... even to the point of "totally built kits." Enter the A.R.F. At the same time, certain competition categories, where building and finishing skills were not as critical for earning competition points as flying skills, began to see less importance for maintaining the B.O.M. rule. The first category where this was officially recognized in AMA rules was Formula I Pylon. The pylon competitors voted for this even though realizing that takeoff order in four-plane heats was determined by preflight static judging of all aircraft entered in the contest. Today, with 10-lap times getting down to within eight or nine seconds of the magic one minute, the one-at-a-time release rule is under heavy scrutiny... but that's another story. The point is, Pylon is now a true sport... you can buy and fly... just like any other sport, such as tennis, golf, etc.

Other competition categories, such as



The last, 1946 version of Bob Knutson's canard "Mystery Model" from August Workbench. More info in text this month.





Ed Jeryak's slightly modified (extra 1-1/2-inch fuse behind wing) Grasshopper from November issue. No. 63 is his 63rd plane. Plans to build No. 65 by his 65th birthday, November, 1988.



Skip Ruff's dad, Gordon, looks skeptically at the R/C Martian Space Ship, as described last month. We'll keep you posted.

soaring, and precision aerobatics of fixed wing aircraft and helicopters, will probably soon come into the sport category. . . buy and fly. . . though in all of these, just as in pylon, the hobbyist, who still prefers to research and develop new ideas and aircraft designs, will continue to do his own thing. Just pray that for the continuance of the whole sport/hobby, there will always be enough creative minds to perpetuate it.

As for Scale. . . I guess you knew this was coming. . . the B.O.M. rule is in serious jeopardy, and understandably so. Today's competition level Precision Scale model . . . which earns a high percentage of its competition points based on its static fidelity to scale, its color and markings, and its workmanship. . . on a 1 to 100 basis, mostly occupies a huge grey area from 10 to 90. Below 10 is the scratch-built model that uses a factory-built engine and radio, with everything else built by the modeler, using tools in his own shop to produce parts from raw materials. Above 90 is the purchased model in which the owner installs the engine and radio. . . maybe. In between 10 and 90 lies the "kit model," which may include fiberglass fuselage and fin with molded-in rivet detail, panel lines, fillets, etc.; instruments and panels; retractable landing gear and flap mechanisms; finished flying surfaces with hinges in place; canopies, bubbles, and formed windshields; rigging wire, control cables, and turnbuckles; and on and on and on. Where is the line between "building" and "assembling" the model? Is "assemble" what you do at the field, or in your shop?

Bet you thought I didn't have a simple answer to this problem. It's easy. Split Precision Scale into three classes; Under \$500 Precision Scale, Under \$1500 Precision Scale, and Over \$1500 Precision Scale. Include with the Scale Documentation a folder containing all of the Proof of Purchase slips (they should all be stamped "Paid"). . . Okay, tongue out of cheek. There is no easy answer to this problem. It has been under discussion by serious scale modelers for many years.

Sport Scale could drop the B.O.M. rule if it was changed back to the way it was originally intended. . . a flying event for scale aircraft, where your only documentation was simply proof that the aircraft you enter

to fly is a recognizable model of the real thing. . . period. Unfortunately, the Scale committee back then chose to complicate matters by removing the "period" and adding a bunch of judgeable scale requirements.

Competition free flight, even if R/C should become legal for recovery purposes only, should never be endangered by serious efforts toward manufactured ARFs. The requirements for really competitive F/F aircraft are way beyond the capabilities of

mass production, and there wouldn't be a large enough market to support the effort anyway. As for control line. . . at the moment there doesn't seem to be an immediate B.O.M. threat, but with the recent increase in this facet of the hobby, and with electric power to solve the close-to-civilization environmental objections (spell that "noise"), it may be something to reckon with in the future. Remember,

*Continued on page 107*



### ADVICE FOR THE PROPWORN

—By Jake

Dear Jake:

*I built a model of the U.S.S. Constitution, but it became waterlogged and sank. I'm not sure where I went wrong.*

*Awash in Altamonte*

Dear Awash:

Well, what did you expect? The Constitution was drawn up in 1787 and is on a very old piece of paper. Why would you put a model of it in the water anyway?

Jake

\* \* \*

Dear Jake:

*Last week at a model contest I saw a WWI scale model of an airplane I didn't recognize. I asked the builder what it was, and he*

*said it was an "Armstrong Whitworth." That didn't help me much, so I'm writing to you to ask: exactly what is an Armstrong Whitworth?*

*Joe in New Wilmington, Pennsylvania*

Dear Joe:

About \$135.

Jake

\* \* \*

Dear Jake:

*If I built an R/C helicopter with the rotor blades down at the bottom instead of up above, would it be capable of cutting my grass?*

*Virgil in Vergennes, Vermont*

*Continued on page 106*

# OVER THE COUNTER

All material published in "Over the Counter" is quoted or paraphrased from press releases, furnished by the manufacturers and/or their advertising agencies, unless otherwise specified. The review and/or description of any product by MB does not constitute an endorsement of that product, nor any assurance as to its safety or performance by MB.

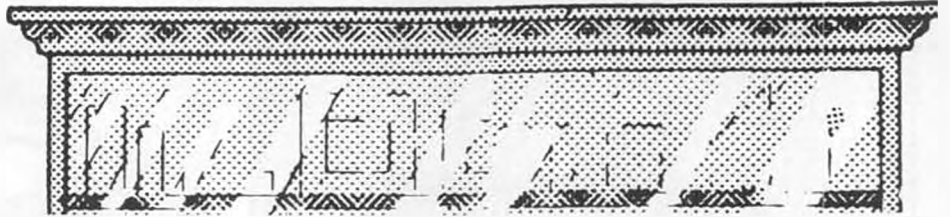

• *Warbirds Worldwide No. 5* is the latest edition of this colorful publication from England available from Zenith Aviation Books. The 48 pages are chock full of vintage photos as well as many contemporary pictures of restored warbirds. At \$9.95, this 8-1/2 x 11 softbound book will make a valuable addition to your library of aviation books and magazines. You can get yours directly from Zenith Aviation. See their ad in this issue.

\* \* \*

Carl Goldberg Models has just introduced a new sport trainer, the Eagle 2, an updated version of the successful Eagle 63. The Eagle 2 has a realigned engine placement, redesigned tail, improved climb-to-glide transition and reposition landing gear for smoother takeoffs and landings. Included in the kit are molded hinges, a universal servo tray, and aileron torque assembly. And the instruction book is all-new too. For more information, contact Goldberg Models, 4734 W. Chicago Ave., Chicago, Illinois 60651.

\* \* \*

When you're ready to cover your Eagle, maybe you'd like to try Glitterstripe trim-sheets for that last touch of creativity. Manufactured by Top Flite Models, Glitterstripe can do things paint can't. No need to mask off tedious pinlines and stripes. Simply cut out Glitterstripe and the adhesive trim sticks easily to your model covering. It's

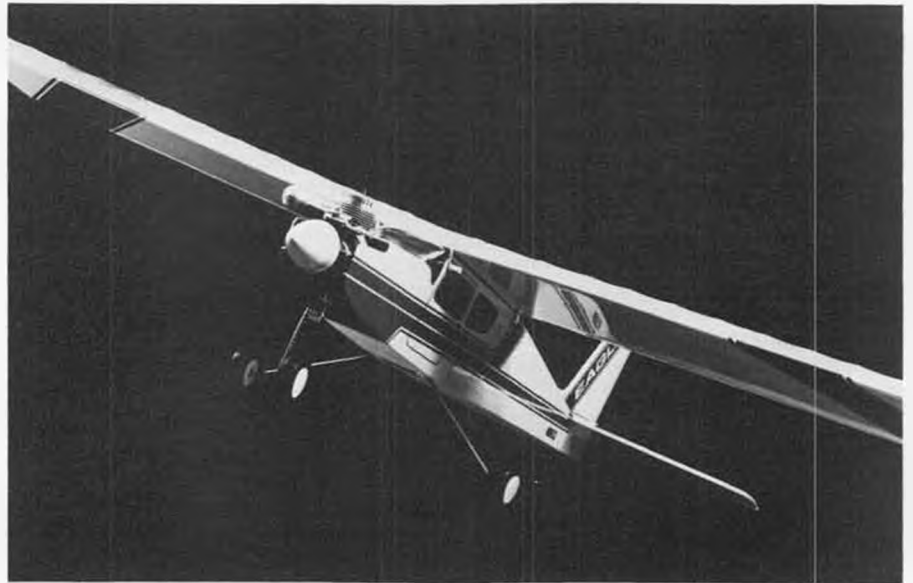

Carl Goldberg Models' new Eagle 2 Sport Trainer.

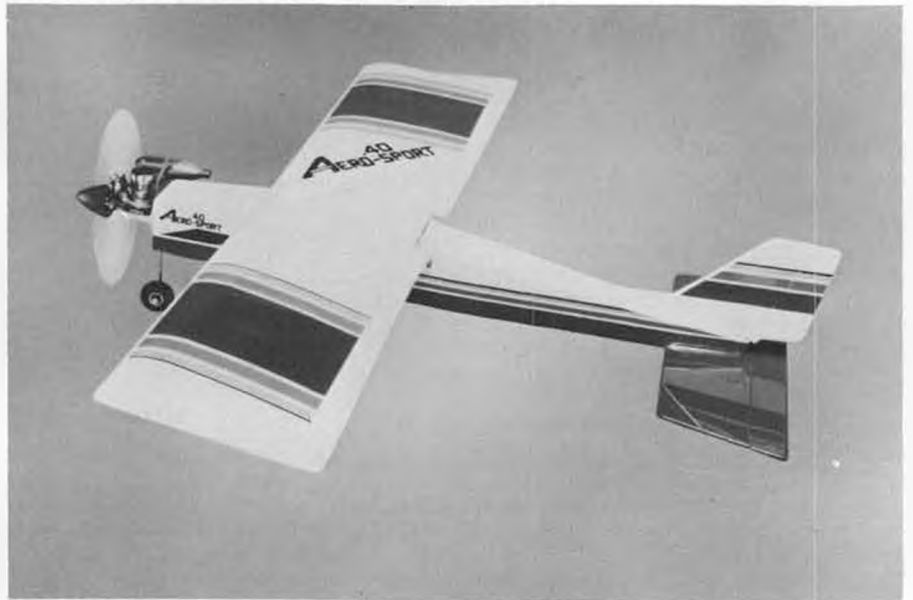

Aero-Sport 40 from Midwest Products.



Warbirds publication from Zenith Aviation.

fuel-proof too. For more information, contact Top Flite Models, 2635 S. Wabash Ave., Chicago, Illinois 60616.

\* \* \*

New wheel pants from Ace R/C are a great way to dress up your model. They're made from rugged .060 ABS plastic, go together quickly, and can be painted with any dope, enamel, or epoxy. Molded into the pant is a flat area to simplify mounting to the landing gear. There's a size for planes

from .20 engine size to 1.20 size, so check 'em out! Ace R/C, 116 W. 19th St., Higginsville, Missouri 64037.

\* \* \*

Concept Technology can enlarge or reduce your drawing or plan to whatever size you wish, accurately and economically. Original plans are scanned into a computer, mathematically enlarged, and then redrawn on a computer output unit. This avoids distortions inherent in optical en-

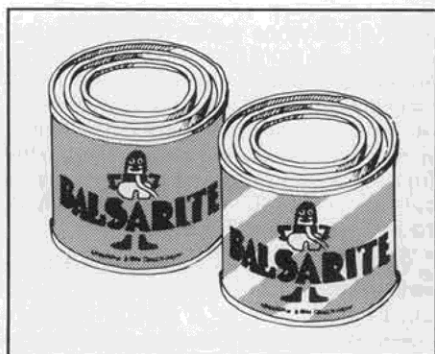

Balsarite's new formula from Coverite.

larging technologies. Concept Technology specializes in giant-scale projects. No drawing is too big, and no source drawing is too small to be of use. For more information, contact Concept Technology, Box 669, Poway, California 92064.

\* \* \*

Upgraded expressly for the sport flier, the new Cox .049 and .09 Medallion engines are now packaged with a muffler and a throttle. With a front rotor, the Medallions offer the higher performance and smoother running that experienced modelers require for their precision airplanes. These quiet engines provide the quickness and responsiveness that advanced R/C flying requires, without creating objectionable noise levels. Look for these new gas engines at your Cox dealer, or write: Cox Hobbies, 1525 E. Warner Ave., Santa Ana, California 92705.

\* \* \*

Sig Manufacturing has a new cyanoacrylate line of glue that has been designed primarily for aircraft modelers. Three years of testing and evaluating have led to this new product, called Sig CA. There is a thin, medium, and thick viscosity CA along with a debonder and a Kwik-Shot accelerator for those who don't think "instant" is fast enough. Look for the new Sig CA glues at your nearest Sig dealer. You won't be disappointed.

\* \* \*

Three new Aero-Sport models are available, a .20, .40, and a .60, each of them easy to build and fly. These three new Success Series sport models have pre-cut wood, all hardware necessary, and an instruction

*Continued on page 93*



New cyanoacrylate glues from Sig Manufacturing.



Wheel pants from Ace R/C.



Cox Hobbies' .049 and .09 Medallion engines.

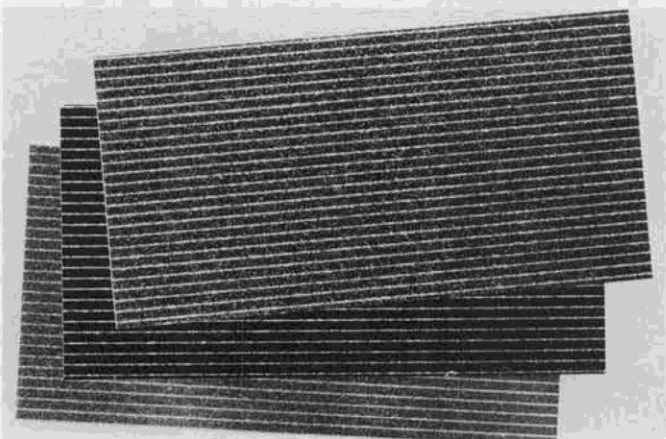

Glitterstrips for decorating models by Top Flite.



Epoxy glue and Quick Sand from Hobbico.

# BIG BIRDS

By AL ALMAN



• Greetings, Big Bird lovers! Big "Al" has once again sprained his brain and asked me to grace his Big Bird column with some wisdom and wit. Unfortunately my stock of both is usually pretty low, but I will stumble along somehow. Incidentally, Big Al is recovering from kidney failure, so now is the time to nail his hide to the wall, while he is still weak and getting used to being on a kidney machine. Al has told me several times if he had known he was going to live this long, he would have taken better care of himself. I always thought he was joking. Seriously, we are glad you are feeling better, Al.

I have had the job of being IMAA's Safety Officer for some months now, and a lot of serious accidents and incidents have come to my attention. I would like to share some of this information with you.

Big Bird Safety can be complicated, however it need not. When we are out flying our models, no matter what size, there are a few questions it's always beneficial to ask ourselves before we rush off into the sky. One question I ask myself, especially when preparing a Big Bird, is "Would I get in it and fly it if it were a full-sized aircraft?" If the answer is no, then I would question whether the model is safe enough to fly around family and friends. Another good question to ask yourself is, "Does my plane meet good noise pollution standards?" Noise does cost flying sites even for Big Birds. If you cannot find a good muffler, Hobby Lobby has a fine selection of German mufflers that work on

engines up to 2.5 cubic inches. They are expensive but extremely quiet. In West Germany no models are allowed to fly that exceed the noise pollution ordinances.

Some people get pretty upset when you try to explain the flying site safety rules to them. Safety rules are really only reminders to think of the other person so that your modeling activities do not cause physical harm to others.

Heaven knows, we often cause harm to ourselves in a moment of thoughtlessness. A case in point would be a friend of mine who was using some old glo fuel to start a fire in his fireplace. This fellow spent several months growing back new skin, and his house was nearly burned down. Now, as you know, most Big Bird fliers are extremely careful with gas cans, but alcohol is pretty dangerous too, and it usually burns with no flame.

Another fellow was out in the woods trying to burn a slash pile; it was not going too well, so he threw a plastic bottle of old glo fuel on the fire. All went well for about 10 seconds, then the bottle became a rocket nearly striking the fellow in the head.

The point I am trying to make is this: We seem to have gone overboard on gasoline safety but totally forgotten the danger of glo fuel. Most cities now have hazardous waste disposal sites and recycling plants where oil, combustibles, and other dangerous materials may be safely disposed of. It may be worth your life to use one of these sites.

Most of us just get a funnel and start pour-

ing our fuel when we are mixing new fuel or transferring old fuel. How many of you folks ground your funnel, bottle, and any attached tubing? Not many I bet. Several serious fires have occurred here in the Northwest. They were caused when inflammable liquids flowing through nylon funnels caused static electrical sparks, which caused an explosion and fire.

We could all save ourselves considerable embarrassment and expense simply by taking a little more time at the flying field to adequately prepare our planes for flight. A good practice is to use a drip can to catch fuel overflow; things can get pretty soggy around the pit area if you just let fuel run on the ground.

Al has mentioned several times that a good method of restraining our Big Birds is necessary; however, most folks do not even have a helper when they fire up their Big Bird. I would strongly recommend any modeler to never fly alone, and even if you are using a safety board to hold down your plane, always have someone there with his hand just resting on the plane.

Bob Benjamin, *Model Builder's* resident aviation artist, would certainly agree with the above statement. One of our local fliers decided he did not need help to fire up his Quadra-powered plane, after start up he laid down his transmitter and began to walk around his plane. At some point his pant cuff caught on the throttle lever and gave the Quadra full power; his plane chewed up Bob's plane and tool box before coming to a halt.

Always have a spotter to help keep you in clear air. It is difficult enough to try to stay below 400 feet; a spotter may help you avoid a midair collision or the occasional full-size plane that may venture below his minimums.

A practice I have given up personally is standing in front of my model and running up to full power. Always start at idle, then move in back of the plane prior to full power check out. There have been many serious injuries to modelers standing in front of their models and running the engine up to full power.

Many of us that fly the bigger-sized planes use several battery packs in our planes. It is a good habit to check each pack



Dick Taylor's Zenoah G-23-powered 4-120 flew at Ace R/C's Float-Fly back in June. Flight performance was exceptional, but it was terribly noisy!



Also flown at Ace's Float-Fly was this scratchbuilt monoplane by Paul Grubich.

with an Expanded Scale Voltmeter prior to flying, even if you have a redundant system.

Speaking of redundant systems reminds me that I was recently talking with Joe Utasi, head man at Jomar Products. Joe was telling me that a lot of you fellows flying Extra 230s and the Big Lasers are experiencing some spurious glitches. Joe thinks there are two reasons this may be happening: the first is that the tail bracing is causing interference with reception, and the second is that some fellows are putting their receivers right next to a very long aluminum spar.

Joe explained that the metal rods or wire cable tail braces or the aluminum spar will act as either a director or reflector to our radio signals. Directors we can live with, reflectors are going to bend our Big Birds. You may eliminate the wire bracing on your Extra 230 and Laser by using Aramid cable; it is nonconductive and is as strong as steel cable. It is also available from Jomar and Aero Space Products.

I cannot pass up the opportunity to say that I really like Joe's Glitch Buster. I have been using one for two years. Even though I have had some pretty long aileron leads, I have never experienced any problems, nor has my receiver had to contend with voltage spikes caused by those big servos that I use.

I have related things that will help you safely fly your Big Birds, and I hope you will notice you have not heard about a lot of extra expensive equipment. Safety is a state of mind that you have to put yourself into. Safely flying our Big Birds takes a conscious effort on our parts, so think about what we are operating and how it is going to effect those around us. Safety is insuring your well being and those around you. In effect, the Golden Rule.

Not all of our problems are created when we shoot our models in the foot. I am going to mention several planes that I have personally witnessed having problems.

I want it clearly understood by both the manufacturers and designers that my statements are not intended to be detrimental to the planes; they are basically excellent kits and semi-kits. I am simply trying to keep everyone involved from reaping the costly effects of a disastrous model crash.

The first plane is the Robin 99 by World Engines. This plane is an excellent flyer and ruggedly built; however, I have seen two tail sections come off in flight because the builders had failed to put any type of bracing on the tail section. Both pilot/builders assured me that the plans showed no bracing; they certainly have them braced now. Incidentally, the Robin 99 is a tough plane; neither plane sustained any serious damage when the tail sections came off in flight, and both are back in the air flying better than ever.

Two other fine planes that are experiencing difficulty are the Behrlens Travelaire 2000 and 4000. These are really nice semi-kits and plans. However, on the 2000 and 4000 Travelaire Biplanes, the center of gravity is located on the plans under the bottom wing's forward spar. This is about four inches too far aft. July 4, 1988, I

*Continued on page 74*



Jim Miller's ST-2500-powered Wimpy was one of the many birds at the Puget Sound Roc's first Float-Fly.



Another good-flying bird at the Roc's Float-Fly was Ken Rowe's Balsa USA Cub.



Roc member Bruce Gale scratchbuilt this Aeronca C-3. An O.S. 90 twin made takeoffs look like a piece of cake.

# CHOPPER CHATTER

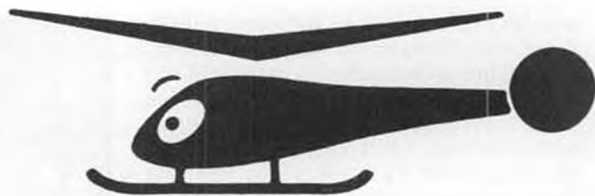

BY DICK GROSSMAN

• There are people who feel that doing an autorotation is like jumping from a burning building. The one you do in practice is almost as dangerous as the one you do for real. I'll admit that I must have done at least 30 emergency autorotations before I ever did my first *intentional* one. The funny thing is that almost all the emergency ones were successful. Doesn't that prove how safe autorotations really are?

*What is it?* An autorotation is a controlled free-fall by a helicopter. It's purpose is to provide a way for a helicopter to land safely in the event the engine quits. We'll see it has other uses as well.

*The way it works:* If the engine quits, collective pitch must be lowered immediately, before the rotor head starts to slow down. For an R/C model, the low-end pitch should be two to four degrees *negative pitch*. As the helicopter descends, the air rushing upwards strikes the blades, helping them to continue spinning as the chopper falls. Before it touches down, the pitch must be changed back to positive, which may be as much as 10 to 12 degrees. In place of the engine, it is now the inertia that has built up in the rotating disc that supplies power to the blades. This restores the lift and brakes the fall of the chopper, allowing it to settle softly to the ground.

An equally important factor in the autorotation is the spinning rotor disc, which functions very much like the wing of an airplane. Even though the blades are in negative pitch, the disc slows the descent, permits the helicopter some degree of controlled glide, and actually brings it to nearly a complete stop as it flares at the bottom of the descent.

Of the two elements in an autorotation, 90 percent of the control and braking is done with the glide and flare. Though the rate of descent can be controlled by small changes in the collective pitch, the input of positive pitch is used mainly in the final two or three feet of the auto.

I've read about the theory of autorotations, the techniques of autorotation, even the *history* of autorotation. What nobody tells you is how to actually perform one. That's what I'm going to try to do.

## EQUIPMENT

The first thing required is, of course, a helicopter with autorotation capability. That means that it must have collective (variable) pitch and an autorotation clutch that will permit the main rotor to disengage from the engine, tail rotor assembly, and main gear. Generally a one-way bearing in the main gear is the means by which this is accomplished. (The centrifugal clutch, which is situated between the engine and the main gear to permit starting the engine, is *not* adequate for this purpose.)

The best rotor blades for doing autorota-

tions are those that are weighted at the tip. They provide extra inertia which keeps the rotor head turning after the engine is shut off. With respect to the blade design, semi-symmetrical and flat-bottomed blades seem to provide more lift with less drag than fully-symmetrical blades; so they're better for autos.

## SET UP

Negative pitch is required to do an auto. Not too little, not too much. With too little negative your helicopter will have a long, flat approach, settling down far from where the auto started. And that's if you're lucky. The rotor speed may have decayed so much

that the blades will stall, and the helicopter will plummet to earth. Excess negative pitch will cause the chopper to drop too quickly, at a very steep angle, requiring such a violent input of back stick and positive pitch that it is almost impossible to achieve a controlled touchdown.

Usually -2 to -4 degrees is the range of negative pitch we're looking for, though for the positive pitch, the more the better, up to 12 or 13 degrees.

## PREPARATION

Practicing autorotations involves using the throttle hold feature of your radio. The more sophisticated radios have many in-



Dwight Shilling perfecting his auto technique.

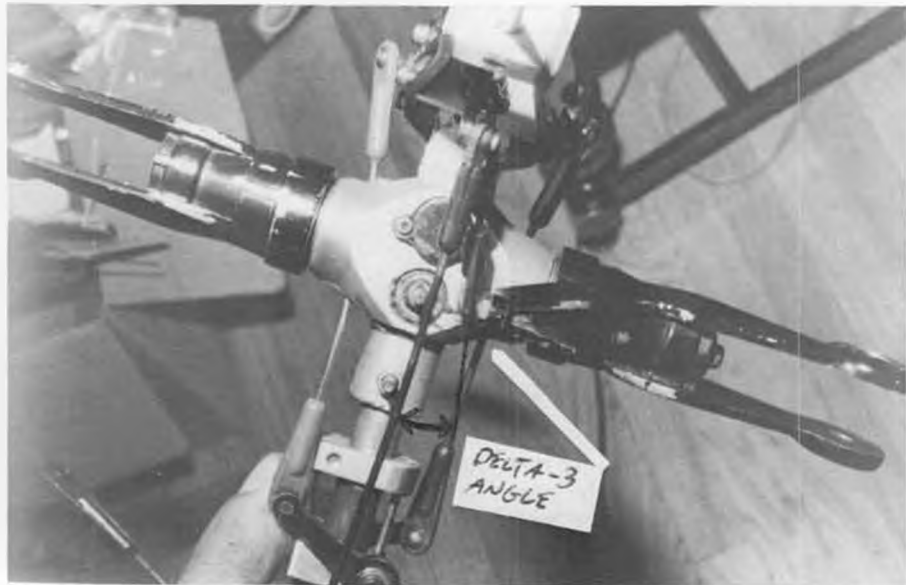

Shortening blade holder and using shorter pivot ball creates Delta-3 hinge, a waste of time.

dividual adjustments that enhance the throttle hold function. The only vital one is that the throttle and collective controls can split, permitting the throttle to be locked into an idle while the collective operates normally. This duplicates the effect of a "dead" engine, except, of course, you don't have to restart the engine after each auto. Also, you can abort the auto at the last second if you need to. Other adjustments possible are a separate pitch curve as found on the JR Galaxy and Airtronics Spectra; a programmable delay of up to three seconds before the low-end pitch setting kicks in, which is found in the Futaba PCM 8; and many variations found in other radios.

Familiarity with the location and operation of the throttle hold switch is very important and should become second nature to the pilot before an auto is even attempted.

#### DRY RUN

Practice starts with full power descents, without using the throttle hold. When the power is cut, the rotor will disengage from the drive train and actually begin to freewheel. As the chopper approaches the ground, pushing up the throttle will add pitch to the blades and bring the engine back up to full speed. The drive train will reengage the autorotation clutch and add power to the blades. You can see that doing this type of descent very closely approximates a complete autorotation, with the exception of the final touchdown. Repetition of this maneuver is good practice for the "big one," and it's a way to determine that your chopper is set up the way you want it. Watching experienced fliers is helpful in learning how to compensate for different weather conditions. For instance, a little more negative pitch is needed when auto-ing into a strong head wind. Having established the proper line and angle of descent, you're ready to perform the same maneuver, power off.

The low stick pitch that you use for normal flying may be different from the pitch you want for an auto. I fly with a lot of negative pitch at low stick for aerobatics, far too much for doing smooth autos. So when I activate throttle hold, a couple degrees of positive pitch gets added to the low end. That's exactly the opposite from the way former U.S. champion Robert Gorham does it. He sets his helicopter with -2 degrees for F.A.I. flying and -5 degrees for autorotations. But that doesn't mean that he uses all that negative pitch for the auto. It's there in reserve to make the fine adjustments he needs to drop his machine right on the mark. In the learning phase, it's better to have the right amount set up from the start—one less thing to think about. In any event, be sure that the settings you're using in practice are the same ones you'll use for real.

#### THE TECHNIQUE

Nothing magical happens when you hit that throttle-hold switch. It's still a helicopter and you have to fly it like one. The big difference is the lack of tail rotor, since the entire tail rotor assembly is disconnected from the rotor during the auto. Steering is done entirely with the pitch and roll control, which remains effective while the rotor



Mike Robbins with beautiful Russian Hind -D.

is freewheeling. Slowing down the descent is done mainly with back cyclic, though a small amount of collective can be added back if the descent is too fast.

The "flare," which works much the same in an auto as it does in a normal power-on approach, results in a flatter angle of approach. Flaring too much and too high can create a situation where the helicopter will level out and stop too high above the ground. This requires immediately lowering the nose with forward cyclic and trying to get closer to the ground. Don't panic! You probably have enough momentum left in the rotor head to complete the auto without any damage to your chopper. Your flare should be smooth and gradual, starting 20 to 25 feet above the ground. Don't forget to allow for the fact that there is a slight lag between the time of your control input and the actual braking of the chopper. Allow for that lag, and don't immediately add more flare thinking you didn't put in enough in the first place. The first flare will level the flight path somewhat, while the smooth input of addi-

tional back cyclic will raise the nose and slow down the forward speed, while still permitting the helicopter to continue descending. Fixed-wing pilots will see that an autorotation is the helicopter equivalent of a "dead-stick" landing. Ideally, your chopper will slow to a stop no more than three feet from the ground. At this point, forward cyclic is used to bring the nose back to level, and roll cyclic is used to correct any leaning. The remaining collective pitch should be smoothly added as the helicopter descends the final couple of feet. You may not need all the remaining positive pitch, and, in fact, slamming in all the collective pitch could cause the machine to jump several feet into the air leaving you high and dry with no rotor speed left. Ideally, touchdown should be made with the helicopter absolutely level, and at zero ground speed. This goal is not always achieved in practice, but you have more of a margin of error than you might think.

*Continued on page 97*

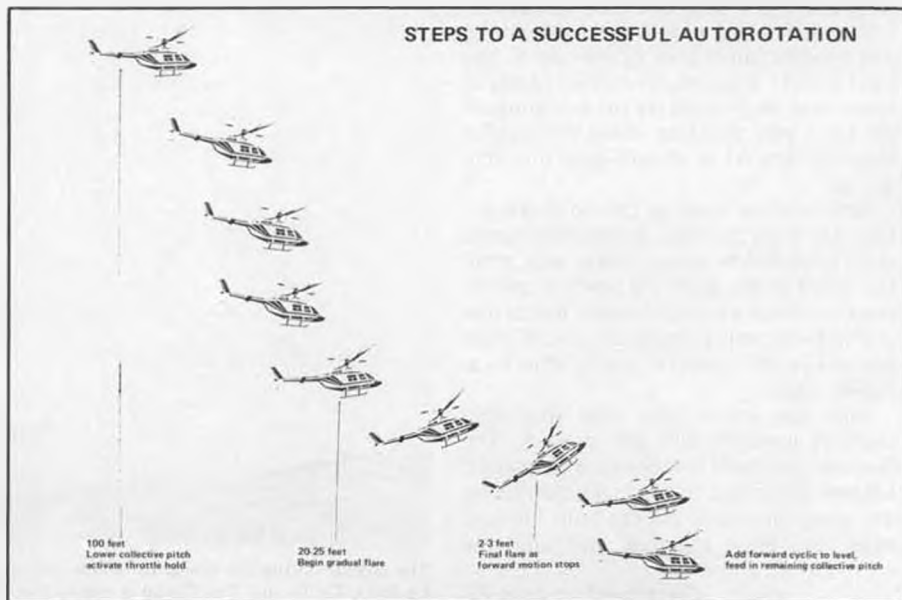

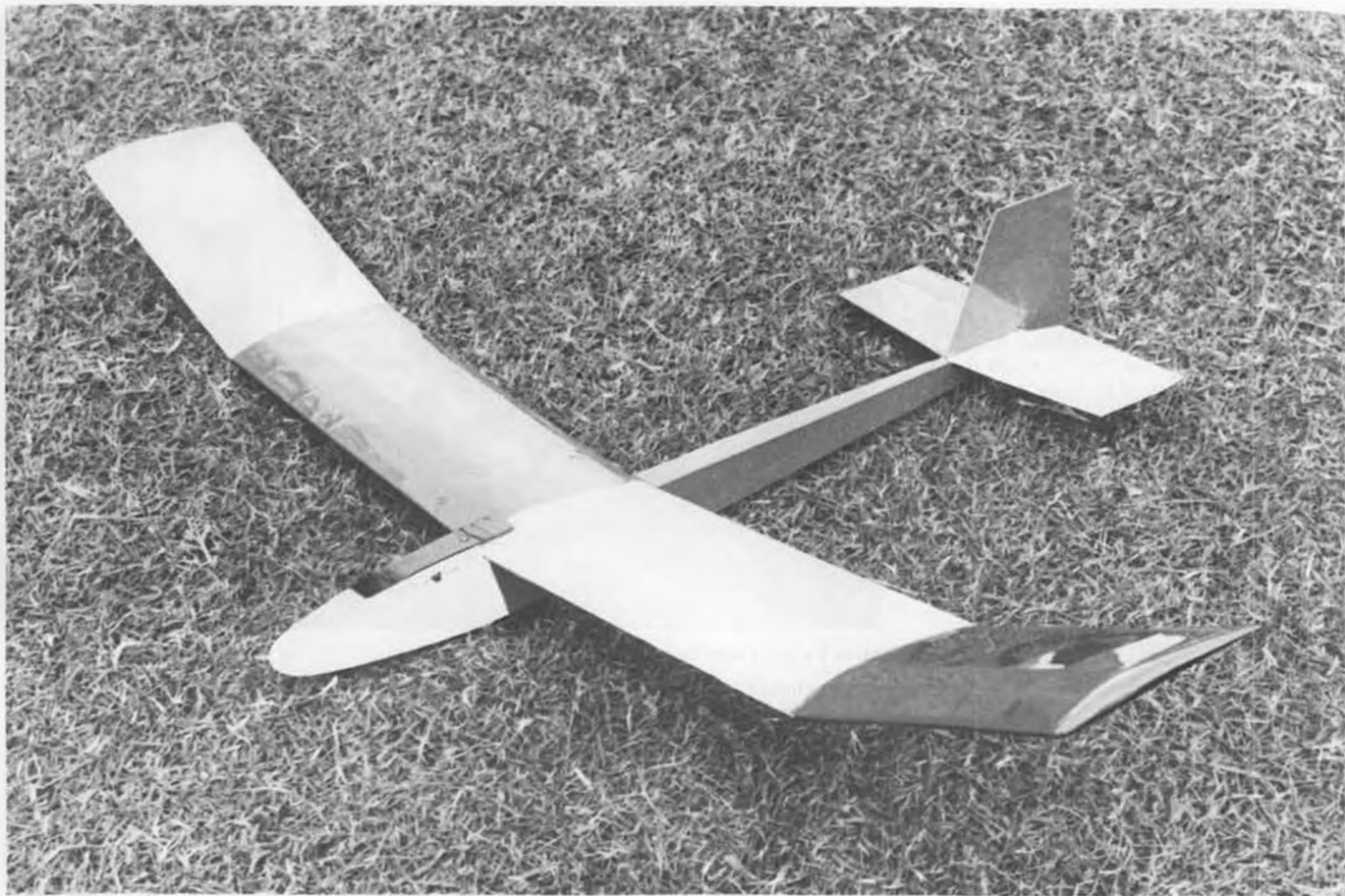

# The Whisp

By JAMES TANK. . . Here's a simple, straight-line R/C glider with a 49-inch wingspan that'll go together in a short time and provide you with an exquisite flyer at a minimum cost.

- The Whisp is a 49-inch span R/C hand-launch glider you can fly almost anywhere. You do not need anything but your arm to get it to a launch height of 40 or 50 feet. With its flat-bottomed airfoil and light weight, it will sustain in the lightest of lift.

You won't need a lot of real estate to fly; just great for lunch hour or after work. The local park or schoolyard provides plenty of room. You might even try ridge-soaring off the local gym building when the wind is blowing. Any lift at all will keep this little guy up.

Well, let's see what we can do about getting one built for you. Before you run to your local hobby store, check your scrap file. Most of the parts are pretty small, so you can utilize a lot of those odd pieces that you've been saving. Make up a list of all of the rest of the material and hit the local hobby store.

Now that you're back with your little stack of goodies, let's get to work. The fuselage gets built first because we use the leftover 1/16-inch balsa to make the ribs for the wing later. First, cut out both fuselage sides, pin them together, and sand the



The author taking the Whisp for a ride above the Pacific Torrey Pines glider park in La Jolla, California. The Whisp is responsive, light, and a fine performer in the wind.

*Continued on page 73*







# Electronics Corner

By ELOY MAREZ

• I promised you meters! Some of you actually asked for a column on the subject. So here goes: Meters!

No, the meters we are going to discuss are not the ones that are 39.37 inches in length, or frequency measurements, like in "Six Meters." We are going to discuss meters as found on the front of transmitters, on multimeters, on the panel of your automobile, and yes, even on the instrument panel of your Lear jet! Nor are we going to discuss digital reading instruments, though a lot of the information to be presented applies to them also. We will discuss only a little bit of theory and a lot more application for the analog needle-indicator meter, the basic electrical indicating device which has been around virtually unchanged since the very early days of electronics. Oh, they look different now, with beautiful case designs, multicolored scales, and some even with internal lighting, but the insides are basically the same.

These type of meters, actually known as Permanent-Magnet Moving-Coil meters, bear the name of the inventor, and are otherwise called "D'Arsonval Movement" meters. They are actually an electro-mechanical device, in that an electric current is used to actuate a mechanical indicator. Refer now to our sketch. The movement consists of a small lightweight coil of wire supported between the poles of a permanent magnet. When a direct current flows through the coil, it creates a magnetic field which interacts with that of the magnet, causing the coil and the attached pointer to rotate. The higher the current flow, the greater the needle movement. It works on current; it is an ammeter. Actually, because we work with small values, they are more sensitive, and designed to operate on sub-multiples of amperes, milliamperes (mA), and more often, microamperes (uA). They

all are! Fortunately, because it makes calibration extremely simple, the reaction is completely linear on a one to one current to indication ratio. In our example, the needle is centered. With the voltage applied in any given polarity, the needle will deflect in a certain direction, reversing the voltage will also reverse the needle movement. In a more common left-hand zero meter, the terminals are marked positive and negative and must be connected with the proper polarity.

This then is your basic indicating instrument. There are highly specialized meters for specific applications, but very close to

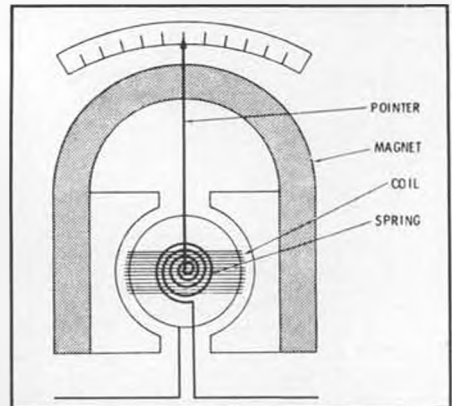

An electro-mechanical measuring device, or D'Arsonval Movement. It is also known as a Permanent-Magnet Moving Coil Meter. See the text for more this month on meters.

100 percent of all electrically driven indicating instruments are basically a milliammeter as described above. This is true of whether the face reads current, voltage, VU (Volume Units) as in your stereo equipment, oil temperature in your car, or altitude on the radar altimeter in your Lear. That is Lesson One; whatever the application, the instrument itself is being driven by current flow!

I will get into just how an ammeter (or milliammeter) is used to measure other values, such as voltage, but first, let us take a closer look at its features so that we may put it to work in whatever manner we need. The first important fact that must be considered about our ammeter is its sensitivity, that being the amount of current required to drive it full-scale. For example, a very common meter movement is the 50 uA (micro-ampere) type. This means that with 50 uA of current flowing through it, the needle would indicate full scale. Any reduction of the current flowing through the coil will bring a correspondingly lesser needle indi-

*Continued on page 80*

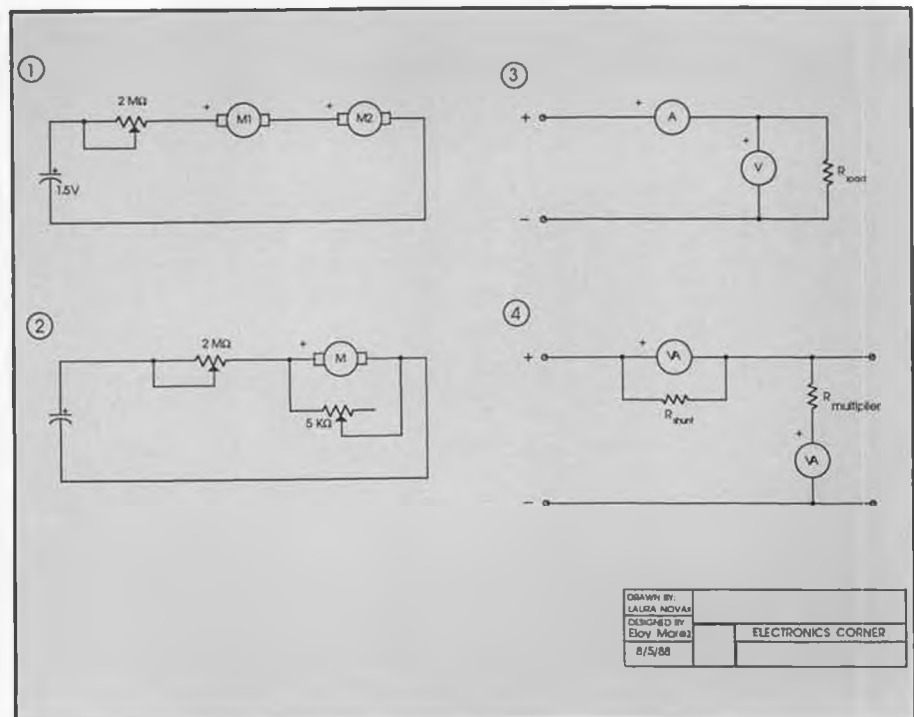

# Pattern Flying

By DICK HANSON

• Last July we discussed trim problems with our friend Bluto. As you may recall, we left Bluto on his quest to find a CG for his model which would not require any elevator trim change when shifting from upright to inverted flight. And now, back to our story:

"Bluto, did you succeed in your attempt?"

"Nope. However, I did succeed in getting a very touchy model, which is no fun to fly." "Sorry to hear that. Do you understand where you went wrong?"

"I guess I just got the CG back too far, but I was sooo close to success!"

"Bluto, baby, you would never succeed!"

"And why not!!?"

"Simple, the wing must provide as much lift upside down as upright. This means the stabilizer must apply as much stabilizing force for inverted flight as it did upright. Remember the stabilizer force on a conventional wing-up-front model is a down force (opposite the direction of lift) at the horizontal stabilizer."

"Huh?"

"Maybe a quick review would help, Bluto. Look here. The wing on your model has a perfectly symmetrical airfoil, correct?"

"Yes."

"That means that we must somehow apply a force to hold the wing at a slightly positive angle (front to rear) in order to produce lift. Remember, Bluto, lift is simply a result of the lowered air pressure on the upper rear section of the airfoil."

"Okay. That's simple enough. And, of course, the horizontal stabilizer 'stabilizes' the wing at this desired angle. Correct, mon

capitan?"

"Touché. But before you get too frisky, let's look at a sketch of your model and then run through a few imaginary conditions."

"Okay by me."

"Suppose the model is flying straight and level at 100 mph, trimmed perfectly for hands-off flying."

"Okay."

"Now just suppose the CG shifts forward and just keeps shifting that way. What must you do to hold exact level flight and 100 mph?"

"Dick, I would add up elevator trim as required. That should do it."

"What about the speed loss?"

"What speed loss?"

"Bluto, as you added up trim you added drag—more trim, more drag—more thrust required to stay at 100. Simple, huh?"

"Sounds like flying a nose-heavy model is not really a good plan, Dick, if it requires more thrust to fly at the same speed."

"It's not entirely a bad plan, Bluto. That added drag back at the horizontal stabilizer actually increases general stability—sort of like a drag chute."

"Sorta?"

"Yeah, sorta. Also, when the horizontal stab is required to provide more force, the elevator becomes less effective. You can really see this on a model with a tiny elevator. In some cases it is impossible to get the model to flare on landings as the model loses speed. The stabilizer has simply reached its limit of the down load it can generate. Models which are reluctant to snap roll or spin probably have the same problem. Too much forward weight (for-

ward CG) or too small of a stabilizer/elevator or not enough tail moment (distance from the big wing up front to the little wing on the rear of the model)."

"I understand, Dick. Now, what if we go for 'tail-heavy' with this imaginary model?"

"Well, this time, if the CG starts shifting rearward we must decrease the download on the horizontal stab to maintain level flight. We also will need to reduce engine thrust to stay at 100 mph; but if the CG keeps shifting rearward, the stabilizer download must also be reduced until we eventually reach a point where any elevator movement will cause the model to pitch up or down. Finally we reach a condition of 'tail heavy,' which requires the stabilizer to now lift to hold the wing at the proper angle. The model is now extremely sensitive to pitch control and may be unflyable by most standards. The United States Air Force flies F-16s which are this tail heavy but a computer runs the stabilator. The pilot simply can't."

"Why would they do that, Dick?"

"Bluto, remember the point that control sensitivity increases with tail heaviness? The amount of control input required for any given maneuver can be greatly reduced. It's great for a fighter aircraft, but a little much for us. We fly by watching the model move, then correcting as desired. We are always a half step behind!"

"Now back to the original point of trying to get a 'no-trim inverted-flight setup: You may have noticed in our examples that even though we changed the stabilizer loads and power settings to maintain the speed and altitude we never changed the angle of the wing."

"Why?"

"Because the model never changed weight, so it always required the same amount of lift."

"Aha! Now I see. The CG has nothing to do with the angle of attack required for lift!"

"Right on."

"So, if we need a half-degree angle of attack for upright flight, we need to reposition the wing past zero degrees a half degree to get a half-degree angle when inverted."

"That's it, Bluto."

"Dick, I've got it: I am going to design an airfoil which provides equal lift upside down or right side up without changing the angle of attack."

"That will do it, Bluto, that will do it. Seriously, Bluto, the only solutions I know of are to either reduce wing loading or increase airspeed. In either case we minimize the angle of attack, but never eliminate it."

"Okay, Dick, how do you set up the CG on your models?"

"Bluto, I just keep shifting the CG back



Sam Gut of Switzerland, on duty in Corvallis, with his original model, powered by an O.S. Surpass .91 and a Graupner 12x11 prop. Very similar to the Runaround model.

Continued on page 72

# ELECTRIC POWER

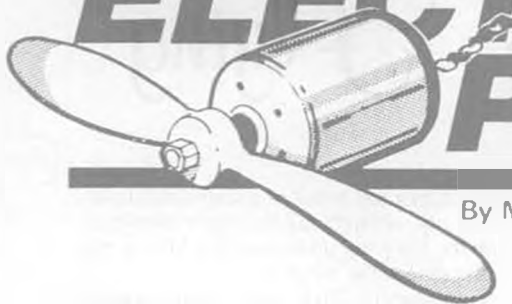

By MITCH POLING

• One of the great rewards of writing a monthly column is the dialogue between the writer and the readers. I get some really great letters, along with the routine "what do I do now" requests. Both types of letters keep my own interest very much alive and well, as I am spurred to deal with new ideas and new problems. It isn't a way to get rich, but it sure is a way to never be bored!

One item that has popped up several times in recent letters was the announcement by Sony Corporation that they have a rechargeable lithium battery. Since that announcement I have heard nothing, and I do not know any more of the story. If any of you get more info on this, I sure would like to hear about it.

Such a battery could well be the breakthrough we have been waiting for, as it would have four or more times the power-to-weight ratio of the nickel-cadmium cells. This would mean four times longer runs, or two times the run and twice the power, or flying weights the same as gas at the same power level as gas and twice the flying time we have now. Pick the combination that suits you! However, as we all know, PR releases have little to do with reality concerning the way we use batteries. If the lithium batteries cannot deliver 10 to 20 amperes without burning up, they will not be very useful to us, and if they cannot be fast-charged, they will mean we have to buy several packs to fly for the day, which could get expensive. I hope Sony gets these cells on the market soon; it's like a seven-year-old waiting for Santa Claus! We may all be dis-



John Foley's setup using CraftAire as a voltage monitor.

appointed; we will have to wait and see.

Ed Westbrook, on the other hand, has written me a series of letters that has been expanding my horizons. He detailed the ways to calculate motor parameters and how to use them to predict motor performance and maximize performance. As Ed says in his letters, this is not new, Bob Boucher showed some motor curves in his book on electric flight and gave some background on how to calculate such curves. What is new to me, though, is how clearly Ed can explain how this is done. The following is my paraphrase of his words so it can all fit in this column!

Bob Kopski presented some really useful data on Astro 05 and 15 motors in the July

and August 1988 *Model Aviation* issues. If you look at the data, you may think that it applies only to the particular motor with that particular battery pack and prop. But, electric motors are a lot simpler than gas, their input/output is so much easier to measure, and their internal characteristics are much easier to describe. So, what more can be done with this data? What I did was not original at all, but I think it leads to the ability to predict what the motor can do with a variety of battery packs or props. The basic relationship for permanent magnet motors is:  $E = I \cdot R + k \cdot \text{rpm}$ .

$E$  is the voltage at the motor terminals,  $I$  is the armature current in amps,  $R$  is the armature resistance in ohms,  $k$  is volts/rpm and is a constant (it is a fixed number for a given motor), and rpm is propeller revolutions per minute.

The  $k \cdot \text{rpm}$  comes from back voltage generated by the motor; as you probably know, a permanent magnet motor acts as a generator when it is spun by an outside source.  $R$  and  $k$  are two basic characteristics of the motor that relate to the magnet strength, number of turns, and the resistance in the windings and brushes. They can be easily calculated for each motor from the data in Bob's column. They can be used to predict rpm or current (choose one) for that motor on any battery pack!

Looking at the equation, you can see that you can get  $R$  and  $k$  by using two different motor runs if you know  $E$ ,  $I$ , and rpm for each. It is the old high school algebra solution of simultaneous equations. Bet you never thought this could apply to real life problems!

Once you have  $R$  and  $k$ , you can calculate the entire load characteristic curves for the motor. Here's what you do:

1. Assign a voltage ( $E$ ) for the run (1 volt per cell will do; this allows for losses in the battery pack and the wiring).
2. Assign a set of current values ( $I$ ), one for each run.
3. Now you can calculate the following using the  $R$ ,  $k$ ,  $E$ , and  $I$ :
  - a.  $\text{Rpm using } \text{rpm} = (E - I \cdot R) / k$ .
  - b. Power output from  $P = E \cdot I - I \cdot R$ .
  - c. Power input from  $E \cdot I$ .
  - d. Efficiency from  $100 \times \text{power out} / \text{power in}$ .



A wild plane in the air, it's Bill Evans' Scimitar Slo Motion. Direct drive, 14 1200 cells and a 25 cobalt motor.



Mike Charles and his Ultra MK IV with an 86-inch span, and a Mabuchi 550 driving a Carrera 3.28/1 gear drive with a cut down 3-bladed Robbe folding prop.

Now you can use these to run your motor at whatever is "best" for your purposes, max power, max efficiency, desired rpm, etc. You can play with sizes of battery packs to your hearts content, and never buy a cell! Here are some rules of thumb that follow from all this:

1. The max power out is at one half the no load rpm. This is usually at more current than we wish to draw, but note that the 8x4 prop on the Great Planes Thrustmaster motor on six cells is very close to the max power point for that motor.

2. The current at the max power point is nearly one half the stall current.

3. The maximum efficiency is at about half the current for the maximum power. This is usually at less current than we use for satisfactory climb and flying.

Now for some suggestions on motor testing. Some seem to think that no load rpm is meaningless. Not so. It is one of the best points to measure. It is one of the two points you can use to obtain the motor characteristics. You can use it to get a handle on the internal friction losses of the motor, including the gearbox if present. Another good point would be the stall current of the motor, but you risk a burn out, so next best is current under a heavy prop load on a high cell count battery pack. (Figure on setting up this test for about 20 amps max for ferrite motors, 30 amps for cobalt for this load test.—mp) Another good point to look for is one that cuts the no load rpm in half, that is the max power point.

Ed had much more to say in his letter, and I will continue it in the next column. If any errors appear in this, it is due to my paraphrasing! Thank you, Ed, for getting me in motion on this. I think the time has come for us to use all the good data we have and use it to predict performance. It certainly saves a lot of bench time and equipment cost! Here is some of the data Bob Kopski presented in his August column, you may want to try it as Ed suggests.

Geared cobalt 05 on an 11x7 prop:

Voltage	Amps	Rpm
4.57	12.3	4000
5.27	15.3	4500
5.91	18	5000
6.65	21.3	5500

And, not at all last or least, thank you, Bob Kopski, for doing the testing that inspired Ed to write me! We all benefit!

Still in this train of thought, there is a superb article written by George Abbot, in the same issue of *Model Aviation*, August '88, on propellers. The equation that really grabbed me was for calculating horsepower output given just the rpm. I have never seen it written in such a simple form before.

$$\text{Horsepower} = P \cdot D^4 \cdot \text{rpm}^1 / 1.4 \times 10^{17}$$

P is pitch, D is diameter; both in inches.

This is a wonderful equation because we can use it with all that Ed and Bob have said! It gives us the ability to predict propeller pitch and diameter for whatever voltage, current, and rpm we want! That, folks, is power and freedom! A word of caution on this: I ran some preliminary calculations on this, and the  $1.4 \times 10^{17}$  factor seems to be off about 20 percent or so. It gives horsepower



John Mountjoy's Cessna AW was scratchbuilt and covered with Permagloss Coverite. Flying weight is 8.8 lbs. Uses a sport cobalt 60 with 21 1200 cells. It's 1/6 scale.



JP Foley's SE5A with a geared 25 cobalt. It hasn't flown yet; too heavy at 100 oz.

that seems too large. However, it is a solid equation, the power outputs do track input power very well, using voltage times current for input power. However, I get efficiencies of 90 percent, and I know the prop and motor together would be doing very well to get 60 percent. So, a little work seems to be required there.

Much theory, and more equations than I have loaded upon you for a very long time! It will lead to some neat stuff!

I recently learned how to measure no load rpm very neatly. I was at the ROAR Nats, and John Gilmore kindly showed me how easy it is to measure no load rpm by pressing a servo arm (two arms) on the motor shaft. You then tach it just like a prop. It works beautifully! I am guilty of saying no load rpm was not so useful, and I am now learning, as Ed pointed out, that it is a handy number to know. One problem has been that manufacturers have listed rpm but no voltage. Hopefully this will not be so

common in the future.

Now for a complete change of subject! James Hawley suggested a very neat way to make a motor mount, and cheap too! The plastic trough used as a motor mount in his Electra finally broke. Jim went to the hardware store and found a PVC plumbing fitting that had the right inner diameter for the Mabuchi 550 motor. The fitting is four inches long; Jim sawed it in half lengthwise to get two mounts and used PVC cement to glue it in place in the Electra. Jim did not specify what fitting this is, so take your motor with you to check fit. I have not tried Jim's idea, but it seems to me that some of the PVC "T" fittings could work very nicely for a firewall mount. I would try cutting the top of the T so it could be used as a flange to bolt to the firewall, then cut the stem of the T at a diagonal to form the trough. Cut a couple of notches in the trough to retain

*Continued on page 92*



# R/C GUFF, *The Life Story*

By DR. WALT GOOD

## PART FOUR

- The 1941 Nats were also in Chicago with a record entry of 26 R/Cers, of which 12 made scoring flights. Eight of these had a total of 40 flights over the three-day R/C event. Lots of flying, but the Goods would not be competing. Bill and I attended this meet even though we did not enter a plane; we were highly interested spectators. Bill was on his honeymoon and I was finishing my Physics Ph.d. thesis. It should have been finished by now, but I had been firmly requested by one of my professors to rush to



Photo 51.

Washington, DC, during spring vacation to consult on a hush-hush project.

He introduced me to Dr. Hugh Dryden who wanted help with a guided missile project. On walking into his office, I saw three issues of *Air Trails* magazine lying open, showing our R/C Guff articles! I worked there for two weeks but didn't learn what the real project was. Some years later I learned that this was the Navy BAT missile which saw service in WWII.

In any case, this explains why I was behind schedule on my thesis and had no time for entering this meet. Based on any sensible priorities, neither Bill nor I should have been there, even as spectators, but we just couldn't miss it!

Jim Walker won first place with a seven-foot plane using dual proportional controls

on rudder and engine, getting 88 points out of a possible 100. Thus he got his first win on the pretty Roberts Trophy and pointed R/C in a new and exciting direction . . . and on his first try at R/C.

During the years between 1941 and 1945, World War II wiped out all R/C and Nats meets. So the R/C Guff was resting in its box in the attic of my parents' home in Kalamazoo.

By 1946, both Bill and I had gotten established in different states, with wives, small children, new homes, and not enough time to get the old R/C Guff ready to fly again for the 1946 Nats.

However, as spectators, my wife Joyce and I did attend the first postwar Nats in 1946, in Wichita, Kansas, and saw Jim Walker in the R/C event with a new plane.

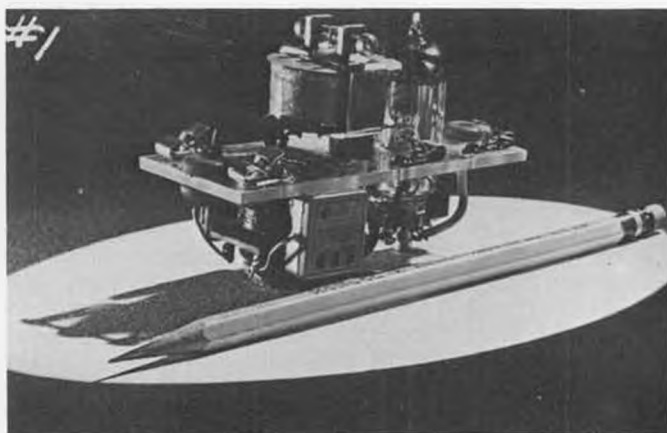

Photo 52.

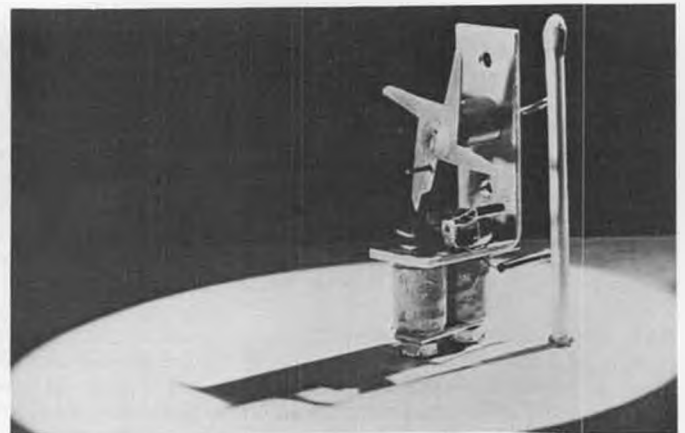

Photo 53.



Photo 54.

Walker's plane had a tricycle gear with a steerable nose-wheel, plus rudder, elevator, and engine speed control. It was to be a forerunner of the multi-control boom which was soon to follow. He won first place in R/C, giving him his second win on the Roberts Trophy.

Now it appeared that if we both entered the next Nats in 1947, one of us might make a third win and retire the trophy permanently! That was to be our goal.

I did enter an R/C glider in the regular F/F Glider event in 1946. It brought a few mild protests even though there was no rule against such an entry. The protests died out as soon as my first flight showed that a Zaic "Floater" with umpteen ounces of R/C gear

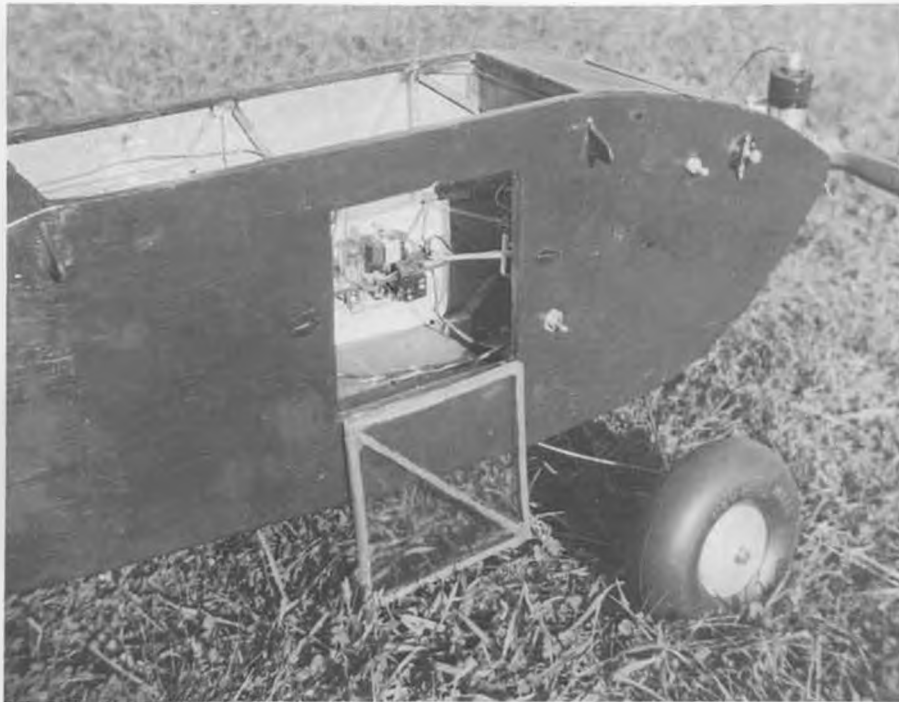

Photo 55.

was not remotely competitive! (*The merry-go-round runneth on! There is discussion of using R/C in some current free flight events. . . most logically for retrieval only, not during the timed portion of the flight, which would remain uncontrolled by R/C. The main purpose is to continue free flight competition in its current state in spite of continuing loss of decent flying sites. This loss was painfully illustrated at the 1988 Nationals.—wcn*)

The 1947 Nats were held in Minneapolis, Minnesota, and Bill and I found we would

be flying the R/C Guff against Walker's 1946 multi-R/C plane.

In 1946 we had designed a single-channel R/C system for commercial sale by Beacon Electronics in Pittsburgh, Pennsylvania. So this new system was installed in the "old" R/C Guff. Some airframe parts were now over ten years old. Furthermore, we decided to go for simplicity and use rudder as the only flight control, plus a thermal delay switch for engine cutoff.

PHOTO 51

The 1947 Guff with the Beacon R/C gear,



Photo 56.



Photo 57.

Ohlsson 60 engine, and new airwheels (the old ones had rotted away in the attic during WWII) and a more rearward landing gear position for easier takeoffs. Holding the control switch is my wife Joyce, at the Beltsville, Maryland, airfield, which was available for testing in those days. The new transmitter was considered highly portable at the time.

**PHOTO 51**

The 1947 Guff with the Beacon R/C gear, Ohlsson 60 engine, and new airwheels (the

old ones had rotted away in the attic during WWII) and a more rearward landing gear position for easier takeoffs. Holding the control switch is my wife Joyce, at the Beltsville, Maryland, airfield, which was available for testing in those days. The new transmitter was considered highly portable at the time.

**PHOTO 52**

The five-ounce receiver used a miniature tube and also held the sensitive relay for the

rudder control. It required four pencells for the filament plus an 8-1/2 oz., 45-volt "B" battery for the plate supply.

**PHOTO 53**

The rudder escapement weighed 3/4 oz. and was mounted inside of the fin. It also required four pencells.

**PHOTO 54**

Bill holds the body to show the new receiver mounted on rubber bands for vibration protection.



Photo 58.



Photo 59.



#### PHOTO 55

A side view of the receiver is shown through the open door. The thermal delay switch for motor cutoff is mounted just forward of the receiver, but only the edge of it shows behind the rubber band. A steady signal of four seconds duration would open the ignition circuit and stop the engine. . . extra points were given even though the rudder would move to half deflection and cause a large circle.

#### PHOTO 56

Here is Bill and I with our Guff on the 1947 Nats field near Minneapolis. Bill holds the control switch just above the transmitter. This transmitter has a tuning dial, in the center of the cover, which tunes it from 50 to 54 MHz in the six-meter Ham band. Sometimes it was necessary to "fine tune" the frequency with this dial when the plane was high in the air and not responding to the commands! That situation was usually preceded with a shout of, "I ain't got it!" This "fine tuning" procedure usually worked.

#### PHOTO 57

Here I am launching by the wing tip for one of the Guff's official flights at the 1947 Nats. Canadian twins in the background are judges. Note relocated gear for better take-offs. This location recommended for anyone building a replica.

#### PHOTO 58

An official flight of the Guff at the 1947 Nats, with Harry Geyer (Good's helper) calling time intervals, I am coaching Bill at the stick, and Judge Ken Carter from Nashville is scoring the maneuvers. The two other judges were twins from Canada and are not in this photo.

#### PHOTO 59

This time the contest resulted in a tie score between Jim Walker and us. That was resolved by a fly-off, which was won by us. This was our third win on the Roberts Trophy, thus retiring it permanently to us.

This was to be the last Nats contest for the R/C Guff after winning four National meets in the years of 1938, '39, '40, and '47.

The photo shows Harry Geyer holding the Roberts Trophy while we stand on guard duty deciding which one will take it home first!

This same Roberts R/C Trophy has been donated recently (December 1987) to the AMA Museum in Reston, Virginia, for permanent display.

The Guff made its final "flights" at the Glenview Naval Air Station near Chicago under exceptional conditions.

In the spring of 1948, the Navy asked Bill if he would bring the R/C Guff to Chicago, where he was living, and demonstrate the Guff as part of a Navy Airshow for the general public. He agreed to help, but informed them that the plane was in Maryland where I lived. "No problem," said the Navy, and directed a cargo plane to Maryland to carry the Guff back to Bill for the show!

At the airfield, the Navy set up a radar which tracked the Guff while Bill stood far out in the field receiving radioed voice instruction for the radar controller telling him where they wanted the Guff to fly. . . as if he was being "talked down" for an approach

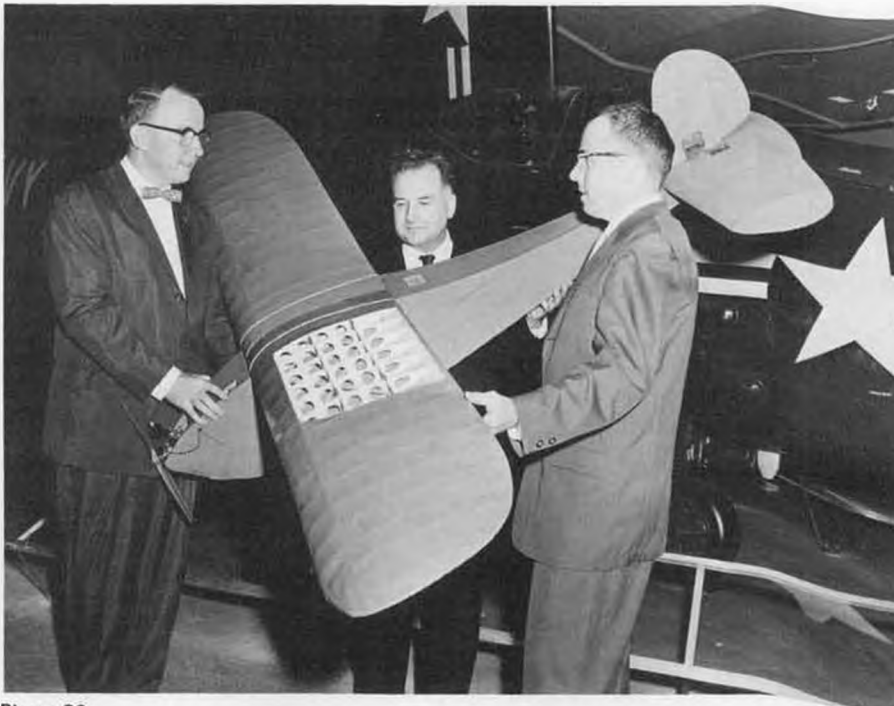

Photo 60.



Photo 61.

and landing at a specific point on the runway.

However, there was just one problem: Every time the Guff was airborne and under good control, it was fine until it rose above 20 feet, then the radar beam would jam the R/C link and lock the Guff into a tight circle! When it spiraled down below 20 feet, the radio control was regained and all was okay. Bill said he had fun, but it didn't make a very good showing for the Navy's new radar! We guessed that the R/C receiver was too sensitive or the radar was too strong. . . or both!

After the Glenview demonstration flights of 1948, the R/C Guff was stored again in the attic until a request arrived from the Smithsonian National Air and Space Museum in Washington, DC, asking for the plane as a permanent exhibit in NASM.

The airframe remained in the 1947 form, but the airborne R/C gear was restored to

the 1940 receivers and escapements. The ground-based transmitter (the 100-watt one) from 1937 was restored to complete the exhibit. Thus, the ages of the various parts varied from airframe pieces dating back to 1935 to some airborne gear from 1938. The engine is our original Brown Jr "B" #1062 from 1936.

#### PHOTO 60

In May 1960 the R/C Guff was presented to Dr. Paul Garber, Curator of NASM, and it has been on display almost continuously ever since.

#### RADIO-CONTROLLED GASOLINE ENGINE POWERED MODEL, 1937

This model, GUFF, is one of the first models to demonstrate radio controlled power flights in which the model could be made to maneuver

# Simply Scale

BY STEVE GRAY

• On the eighth of July, I traveled through New York State's southern tier to a small local airport outside Olean, New York, to attend the annual STARS Scale Rally. The two-day event has been on my calendar to attend each year for the past several. On each visit over these past years, the weekend event had been marked by the rottenest summer weather possible. It had always been cool and rainy, making flying sometimes impossible. Each year I would return hoping that the scenario would not repeat itself, but it always did. The more daring among us would get a few flights in between the showers or sometimes during them. The attendance was always very good though. Scores of scale modelers would bring their planes from all over the area to enjoy the great hospitality of the Southern Tier Aero Radio Society, the STARS. These guys always made everyone feel at home and have a good time, despite whatever the weather would do to us. Each year the modelers would show up, and each year they would get rained on.

It didn't seem to matter though, the STARS' chicken barbecue dinners both days (free for participants), the evening auction sale of new and used model equipment, and the bonfire and wiener roast each Saturday night kept us coming back each year.

It was a bit different this year. There was the same good attendance, the same great hospitality, the same good chicken dinner, and the same great conversation around the bonfire. But for a change the weather was hot and sunny, and everyone got their fill of flying. The tremendous efforts of the STARS shone through, and we again had a terrific time. We almost were disappointed that it did not rain. I think this year's weather has

marked a change in the STARS' luck. The rain may be behind us, but just in case, if you plan to attend next year, don't forget to bring your boots and rain coat.

One of the most difficult aspects of running an event such as the STARS' rally has always been the frequency control system. How do you allot flying time equitably among the fliers and maintain safety without a lot of policing and effort? I think the STARS have a system worth copying by anyone planning a large event of this type. Since this is a fun-fly rally, participants fly when they want to and must take their turn as frequencies become available. For this reason the following system was set up and works beautifully. Best of all, it runs itself.

To begin with, all models are registered and safety checked. The transmitters are numbered and impounded, and the flier receives a numbered tag corresponding to his transmitter. The flier sets up his pit area and gets ready to fly. In front of the pit area, in plain view of all the participants, are several small stakes each with a frequency number and clothespin with the same channel number on it.

Each stake is about 10 feet from the next. There are as many stakes as there are frequencies available. When a participant wishes to fly, he places his model in front of the stake for his frequency with his starting gear. If the pin for that frequency is out, he just leaves his model there until its back. His model holds his place in line for the frequency. If several are waiting for the frequency, they just line up their models. When the pin is available, the pilot takes it to the impound to pick up his transmitter and clips it to the antenna. He then moves his plane up to the flight line and goes flying. When he is done, he returns the transmitter to the impound and the pin to the stake. The next flier then may take his turn.

The beauty of this system is that at a glance, a pilot can see what kind of lineup is at each frequency peg as the planes are sitting there. I have never seen a system that



Great Planes makes this nice kit for a Corben Baby Ace. This one, seen at Olean was built by Bruce Knox and was powered by an O.S. .80 two-stroke. Plenty of power for this 11 lb. craft.



Jack Swift's magnificent clipped-wing Taylorcraft L-12 powered by an Enya 120 has impeccable detail.



Ron Barr brought this Pieterpol to Olean. Model is representative of how a relatively simple project can be detailed into a real winner.



This semi-scale 54 pound DeHavilland Caribou was built by Stan Dzon. Model is 1/7 size and powered by two Sachs 3.1 engines.



A huge 90-inch span Pitts by Gim Goodemote weighing 37 lbs. It is powered by a 10 hp Sachs engine.



This big Curtiss Racer by Ralph Brunner was powered by a Quadra 40. It weighs 26 lbs. and has a wingspan of 95 inches.



This PT22 was built from a Sig kit by B. Matthies. This plane is powered by a Maloney 100 which seems to fit the tight cowl nicely.



A very aerobatic Weeks Special was powered by a Saito 270 and was scratchbuilt by William Morlan.



This very aerobatic 82-inch span Stampe is powered by a ST3000. It belongs to Al Horner from Toronto.

is more practical or more easily run. Organizers may also group frequencies on stakes with one pin representing several possible interfering frequencies if they so desire. No allowance was made for third order intermodulation distortion at the STARS' event or at last year's K-W Scale Rally, and there were no incidents traced to that problem. Adequate spacing between the fliers and a restriction to a maximum of five fliers in the air at a time seemed to eliminate the problem.

The STARS' Rally is an event where one can see a very broad cross section of R/C scale models flown. Everything from a model helicopter to a 54-pound DeHavilland twin-engined Caribou was there, and flying was nonstop. It appears that the majority of scale modelers still prefer fun-flys,

and the STARS' Rally is one of the best. See you there next year.

A special mention must be made of a model I saw at the STARS' Rally. A friend of mine from Toronto, Ontario, Jack Swift, brought his great-looking super-scale clipped-wing Taylorcraft L-12. Jack's model is 1/4-scale, weighs 15 pounds, and is powered by an Enya 1.20 four-stroke engine. Jack is a past World FAI Competitor, and his Taylorcraft looks like it would easily qualify to be entered in world competition. Jack makes plans available for the model through Scale Plans and Photo Service, 3209 Madison, Greensboro, North Carolina 27403; (919)292-5239. Ask them about the price.

There is a difference in the way scale models fly with respect to not only how

much they weigh but how that weight is distributed throughout the model. I always attempt to confine the greatest mass near the center of gravity of the aircraft. In other words, make the tail and wingtips light in weight and install mechanical equipment as near to the CG as possible. In this way the model will have the greatest stability and maneuverability possible. For example, if a model has a long heavy wing with solid balsa wingtips, a heavy paint job, and separate servos for ailerons, you can imagine that the inertia of the wingtips will be felt when attempting to maneuver the model. The heavy wing will require more control surface deflection and hence will generate more drag when the ailerons are

*Continued on page 72*



# PLUG SPARKS

By JOHN POND

• This month's column will feature a report on the Australian Old Timer Champs held for the fifth time at Canowindra, N.S.W. This time the beautiful weather disappeared with a vengeance, as it was so windy on the first day of processing that the control line events, under the aegis of John Abbott, suffered badly; only a few entered.

During the time of the control line events, processing is held on the fair-ground. Photo No. 1 shows a typical session of processing with models (in line?) strewn all about the place. Joe McGuffin and his team of seven were hard-pressed to complete the work in time.

This writer is indebted to John Quigley, 40 Farnell St., Boronia Park, N.S.W. 2111, Australia, for sending a flock of photos. Not to be outdone by the SAM Vice President, President Basil Healy had a good write-up in the SAM 1788 *Duration Times* plus another in *Airborne*, the leading modeling magazine in Australia.

As can be seen in Photo No. 2, Quigley wears a beard, probably as an indication he is with a high-tech electronics firm. The model is not his usual Miss Model Craftsman but a Dallaire Sportster, one this writer considers a better flyer.

However, Australians like to fly all day, and this is required in all their events held one per day. All models are flown on the round system (generally an hour and a half) and only ten-minute flights are required, but you must make four maxes out of five, plus landing in the prescribed circle!

The boys have gotten pretty good, as 24 contestants qualified for the flyoff! This makes for a very long day, as regular flying generally does not end until 4:00 p.m. In spite of the fact they have a multitude of frequencies to fly from, there are still conflicts and flyoffs conducted in series!

Just about the same time this writer received photos from Quigley, then a letter

arrives from Bruce Ramsay of South Australia containing some good shots of the Mass Twin Pusher Flyoff. Seen in Photo No. 3 are all the helpers any man could wish for. Keith Murray is checking his rubber while Paul Mitchell, Laurie Kelsall, and Bruce Ramsay hang unto the model in the breeze.

With all that help would you believe one motor got wound backwards? Despite this, Keith was able to get off a flight, but not enough to beat the winner, Brian Beashel.

In the Texaco Event, good friend Ian White is seen in Photo No. 4 with a rare "Yankee Clipper," this design having been originated by Dick Tanis's dad in the early days of New Jersey.

To this simple model Ian decided to use the "new" O.S. K-6, a 1940 engine that has recently been reissued as reported by the

SAM Engine Acceptance Committee; the engine didn't have much power at 4,500 to 5,000 rpm, but its economy was phenomenal.

This was the strategy to win, but Ian's model was unable to get enough altitude despite the six-minute engine run. And this with only a required ten-minute flight! Truly a shame that the wind kept increasing as the day wore on and, of course, rain! The SAM Champs have been running into poor luck on their fabulous weather.

As stated before, only one R/C Event is run per day as compared to three for the free flight boys. The Duration Event, which is practically a carbon copy of the Texaco Event, requires only four-minute flights on limited engine runs. There has been some movement to extend the flight times, as the American version uses seven- to ten-minute flights depending on whether the design is Old Timer or Antique. The Australians make no such distinction. For that reason, 24 Playboys were entered!

John Quigley has written a special note to run Photo No. 5 showing Steven and Neil White together preparing the 70-percent Long Cabin for a flight. This model has been scaled to suit the 2cc Event using an Enya CXII. Steve and Neil are always at con-



1. All R/C models are processed at Canowindra to ensure uniformity and conformance to scale.



2. Australian SAM VP, John Quigley, seen with Dallaire Sportster at Canowindra.



3. Keith Murray (checking rubber) couldn't complain about a lack of help in getting his twin pusher ready.



4. A rare one! The Tanis Yankee Clipper by Ian White with an O.S. K-6 for power.

tests. Maybe they don't win, but they enjoy themselves.

With rain and wind prevailing most of the time on Monday, the day for 1/2A Texaco and the 2cc Event, the number of contestants was down markedly with six entrants in 1/2A and thirteen in 2cc. This is the event this writer has been trying to plug, as this event fits all those engines between .09 and .12 cu. in. displacement. Between Class A and 1/2A, these engines fall into the "orphan" class, as they are either too big or too small for either event.

In reviewing the results, Steve White did break the ice and place third. One of the main reasons, besides the rain, for the lack of entries was the free flight events which quite a few entered.

Several more photos are in order. Photo No. 6 shows Allan Trinder with a four-cycle-powered Buzzard Bombshell. Allan has embarked on producing old timer kits, and word has it that they are the most accurate and authentic kits of all. Price is in the \$95 (Australian dollar equals about \$70 USA) range, which is not an unreasonable price for a kit. If anyone is interested, we will get the name and address of the manufacturer.

Several years ago, Peter Werzek was my Team Captain at Canowindra. (All contestants are broken up into six or seven contestants which a Team Captain is responsible for seeing all of his team get their flights in during the allotted round.)

As can be seen in Photo No. 7, Peter Wer-

zek has taken a page from the SAM 29 boys in Texas who originated the idea of the 110-percent Cumulus for the Antique Event. As a matter of fact, after four years, Dick Huang is still flying and winning with his model. Peter did not use a glow engine, hoping to gain a longer motor run with ignition setup. This didn't work out, as Pete placed well down the list.

However, Pete did gettun in the 1/2A Texaco Event, as he won handily by over a half minute. Mike Granieri, the US designer would be real proud to find out his MGA won in the Australian SAM Champs.

We would have liked to talk about the free flight events, but information was very sketchy plus darn few photos. It was interesting to note this time that the gas model entries outnumbered the rubber models. Rubber and glider events are popular in Australia. Let's take a look at the results:

#### R/C

##### Texaco (51)

1. Steve Wiessner	Flamingo	O.S. 61 FS	3508
2. Bruce Knight	Flamingo	O.S. 60 FS	3352
3. Tom Prosser	Cumulus	O.S. 60 FS	3334
4. John Quigley	Dallaire	O.S. 60 FS	3296
5. Meryl Wiessner	Flamingo	O.S. 61 FS	3226

##### Duration (50)

1. Meryl Wiessner	Playboy	O.S. 61 FS	1552
2. Steve Wiessner	Playboy	O.S. 61 FS	1542
3. Ashley McDonald	Super Quaker	Saito 65	1530
4. Tom Prosser	Playboy	McCoy 60	1500
5. Mark Collins	Super Quaker	Saito 65	1478



5. Steve and Neil White with a 70% Long Cabin for the 2cc event.

#### 2cc Event (13)

1. Harold Stevenson	Gas Bird	Erya	2215
2. Joe McGuinn	So9 Long	Oliver	2170
3. Steve White	Long	Erya	1887
4. John Quigley	Brigidier	MVVS	1652
5. Bruce Knight	Buzzard	Tyro	1631

#### 81/2A Texaco (6)

1. Peter Werzek	MG-2	1792
2. Neil Molloy	Red Ripper	1751
3. Tom Prosser	Coronet	1728
4. Geoff Shaw Jr.	Playboy Cabin	1161

#### FREE FLIGHT

##### Vintage Power (3)

1. Keith Murray	Stomper	456
2. Geoff Brown	Playboy	421
3. Alan Pearson	Stomper	395

##### O/T Rubber (9)

1. Keith Murray	Korda	477
2. Brian Beashel	Stormont	461
3. Dennis Parker	Lanzo	436

##### O/T Power (4)

1. Dave Bailey	Ranger	294
2. Keith Murray	Ranger	157
3. Dennis Parker	Zipper	87

##### Vintage Rubber

1. Dave Bailey	Climber	360
2. Brian Beashel	Stormont	349
3. Keith Murray	RAFV	306

##### Vintage Glider

1. Craig Pearson	Woodford	378
2. Roy Summersky	Hyperion	326
3. Bill Gordon	Jader 60	307



6. Allan Trinder with good-flying Buzzard Bombshell. Trinder is now producing very authentic OT kits.



7. Peter Werzek with 110% size Shereshaw Cumulus. Engine problems put him in 47th place.

## Twin Pusher

1. Brian Beashel
2. Max Starrick

Next month: SAM Champs at Lawrenceville.

## ENGINE OF THE MONTH

Our acknowledgement for the use of old engines may get a bit tiresome, but this writer has found Bob McClelland, Secretary-Treasurer of MECA, the most cooperative and generous collector to date. This month's engine is no exception, as it is another fairly rare engine.

The Everson 29, this month's subject, was produced by Everson Bros., 6 Franklin Ave., West Orange, New Jersey. The first national notice of this engine appeared in a June 1947 *Air Trails* advertisement. The advertisement continued to August when they abruptly stopped.

The Everson, despite its low price of \$11.50, employed good materials. Part of the saving in costs was selling the engine direct with no discounts to distributors and hobby dealers. This action was based on the successful marketing of the Baby Cyclone engine which enjoyed outstanding records in the direct sales-only market.

The Everson utilized good materials as noted before and featured mehanite cylinder liner, heat-treated centerless ground steel piston, aluminum alloy castings with "frosted" finish. This rotary valve shaft-type engine featured a bronze connecting rod with the main crankshaft bearing being machined from high speed bronze.

Specifications for the Everson engine as a Class B-type of .290 cu. in. displacement resulting from a bore of .687 in. and stroke of .781 in. With an 8:1 compression ratio, the engine has a rating of 1/6 horsepower. This claim was based on 8,000 rpm. Tests showed that the engine attained 7,500 rpm utilizing an 11-8 high-pitch propeller.

The years following World War II were in a tremendous flux at that time with all the pent up energy and designs held back for four years being suddenly released. By 1947, the big sales were starting to fall off, and those engines introduced at that time had a hard time making a place for themselves in the market. The Everson engine, although well made, failed to capture any share of the market and stopped production



8. At the Stewart Napa Ranch in 1940, Tom Smith and John Pond watch a model fly overhead.

in a very short time.

## 46 YEARS AGO, I WAS...

Received some very interesting photos from longtime friend, Tom Smith, who sent in photos of the 1940 Annual Aeroneer F/F Club at Napa (looks like the old Stewart Ranch).

As can be seen in Photo No. 8, Tom Smith is shading himself with a Zomby-type model. On the right, young John Pond needs no such shading as he is seen with his perpetual fedora. There are two still on hand, hung on the model room wall as souvenirs.

Note the old cars, particularly the writer's 1940 Chevrolet (on left) that hauled many a free flight model. Also on hand was a photo of Pond's Ohlsson 60 Rocketeer completely ruined. A switch from Brown Jr. power to an Ohlsson 60 engine proved the undoing of the lightly built Rocketeer. No need to show the gruesome sight.

Tom Smith, who now is retired and lives in the foothills of the Sierras, says he was 46 pounds lighter then. No comment about Pond, who is also that much heavier. No other weights given, nosey one!

## WEST COAST SAM CHAMPS REVISITED

Last issue we didn't get a chance to acknowledge the work of the unsung heroes who make a good meet possible. This meet

drew 145 contestants, only 20 or less than the recent SAM Champs at Lawrenceville.

Seen in Photo No. 9 is George Steiner in a typical study of checking the radio transmitters for correct frequency. Out of all those submitted, only two were found to be emanating spurious signals (not on frequency). This small amount still helped keep down interference to the point where only a few models crashed (what problems occurred were not clarified).

George also runs a small electronic business known as GSP (George Steiner Products). His main interest as of now is the conversion of old sets to the new frequencies. His rates are extremely reasonable. If you have a problem, the best idea is to write George Steiner at 2238 Rogue River Drive, Sacramento, California 95826.

Probably the biggest hero of all was Ted Kafer, R/C Contest Director, who with his boys, Dave Lewis, Bill Vandebek, George Joki, and Steve Roselle, processed all models, totaled all results, and ran a good meet. Ted is seen in Photo No. 10 handing out a prize to Jack Alten.

To get a good idea of what the flying area looked like, Photo No. 11 is presented, showing an R/C Anderson Pylon taking off. Jim Kyncy can't be seen in front of timer, Stan Lane, but the colorful green and pink Anderson Pylon is a real performer.

As a matter of fact, both boys fly the same model with some color differences. Powered by O.S. 60 FSR engines, these models do not take a back-seat to any antique design. Their record of winning speaks for itself. For Texaco, they simply swap the O.S. 60 four-cycle engine with no change in balance. Best part of all is that the mounting holes are the same.

## SAM ITALIA

Latest information received from Cesare de Robertis, Via L. Magalotti, 6, 00197 Rome, Italy, is that SAM Italia is growing very rapidly with the last count at 120 members.

Cesare also sent their newsletter, *L'aquilone* (The Kite), which was copied from the original issue of a famous weekly magazine for young people of the thirties. Seen on the cover is a glider by Giulio Dorio built during WWII of "agave" due to balsa shortage.

Cesare sends several photos of which we



9. AMA R/C frequency coordinator, George Steiner, checked all radios at Stead Air Base, Reno.



10. CD Ted Kafer awards first place plaque to Jack Alten, winner of the Texaco electric event.



11. Jim Kynco's pink and green Anderson Pylon model gets away very quickly. W/C SAM Champs, Reno.



12. Cesare de Robertis, SAM Italia, seen with English Mercury Matador. A Russian MK-17 engine powers the model.

have picked Photo No. 12 showing Robertis with an English design, the Mercury Matador powered by a Russian MK-17 engine about .09 cu. in. displacement. No reports on how it flies.

The present schedule of contests for SAM Italia is as follows: May 28 and 29, National Meeting at Modena; June 26, 2nd National Contest at Lucca (F/F only); September 11, National O/T RC near Pica; and September 17 and 18, International Meeting for all classes.

All foreign old timers are heartily invited to attend. SAM Chapter 62 Coordinator Ivan Poloni, Viale Abruzzi, 14, 24035 Curno (Bergamo) Italy, should be contacted for the big September meet. Details on travel and lodging can be obtained directly from Poloni. Their slogan is "Come fly with us."

#### SAM 58

Latest news from the "Antique Modelers of Central New York" comes in the form of a short letter from George Clapp and results and photos from Dick Sargent, C.D. of the Second Annual Central New York O/T Contest.

Seen at this meet in Photo No. 13 are Walt Geary, Buck Zehr, Walt Lawrence, and Art White. The big winner was Willard "Buck" Zehr, Buck really cleaned house in taking firsts in 90-second Cabin, Texaco, Class B Glow, Class C Ignition, plus second in Antique Glow and third in Class A glow. Whew! Wotta workout!

Other big winners were Walt Geary with one first, four seconds, and two thirds, and Art White took one first, two seconds, and two third places. There wasn't much left after these boys got through!

C.D. Dick Sargent reports weatherwise Saturday was fair, but the wind ruined things after 12:00. Fortunately, Sunday was a dandy with everyone flying to 4:00 p.m.

Rather than list all the competitors, we might summarize other winners: 1/2A Texaco won by Walter Lawrence, Pure Antique by R. Russell, 05 Electric taken by John Fleming, and Class C Glow by L. Davidson.

SAM 58 was formed in March 1985 consisting of six men with George Clapp as President. Today they have 23 active members. As stated before, this 1988 meet was their second annual. Based on the success

of this meet, which drew from four states and Canada, plans are being made to put on the third SAM 58 Annual. For further information, write to R. J. (Dick) Sargent, 105 Chestnut Heights Dr., Liverpool, New York 13080. Don't miss this fun meet!

#### OLD TIMER LISTING

Ernie Linn of the Wichita Historical Aircraft Modelers (WHAM) club sent in the most interesting and complete list of old timer gas and rubber models compiled from all of the old magazines running from 1930 to 1943.

As Ernie says, with the help of Jack Phelps and Bob Prokes, they are making this list available to others with the hope it will be helpful in locating and choosing forthcoming projects.

The list is available at a nominal cost from Ernest Linn, 3505 East Mt. Vernon, Wichita, Kansas 67218. Ernie has not indicated price, but if you send \$3 this may be enough. Well worth the investment.

#### READERS WRITE

Received some very nice photos from Dale Myers, R.D. #3, Stewartstown, Penn-

sylvania 17363, showing two models built and flown by him.

We have selected the Courier Sportster as originally kitted by Berkeley Models. Photo No. 15 is deceiving in the respect the wing appears to have no dihedral. Photos taken from a frontal view show standard dihedral of one to the foot of wingspan.

We are pleased to run a photo of Myer's Sportster as it is the first one we have received on this particular model. The Berkeley kit was never too popular and was withdrawn after several years of marketing. The Buccaneers were far more successful flying models.

#### WE NEVER MAKE MISTAKES

In the Plug Sparks column of the April 1988 issue of *Model Builder* we ran a good closeup shot of Clarence Bull's 1/2A Texaco Lanzo Bomber featuring a Cox Medallion 049 for power.

A month or so later, a letter was received from Morton Ross objecting to the use of a Cox Medallion asserting that 1/2A engines were limited to rear reed valve-type engines such as the Black Widow, Golden Bee, etc.

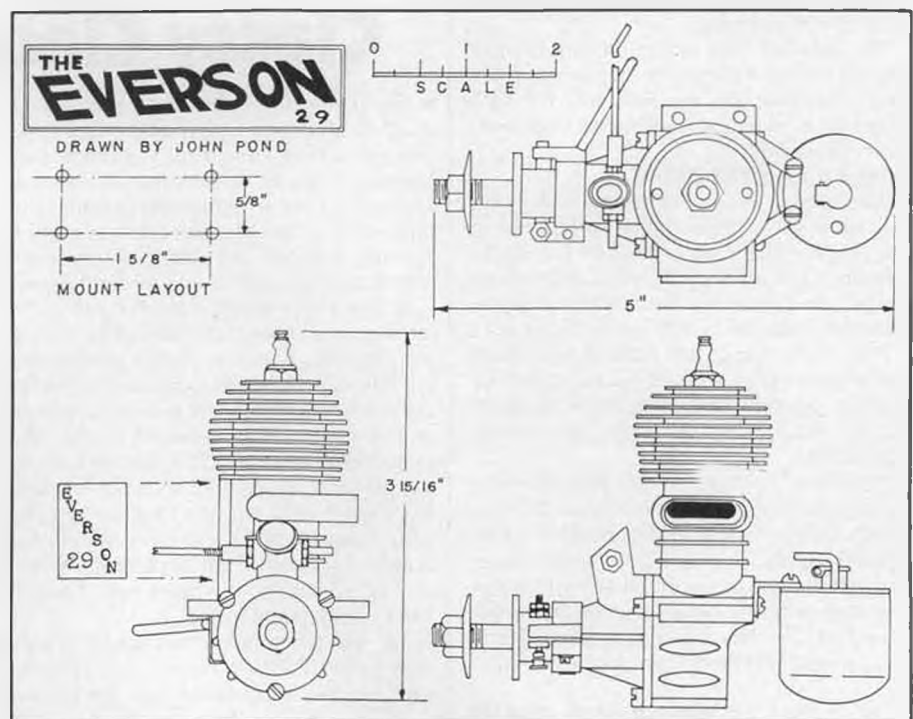



13. A group of winners from SAM 58 Central New York contest: Geary, Zehr, Lawrence, and White.



15. A Berkeley Courier Sportster as built by Dale Myers of Stewartsville, Pennsylvania.



16. A Canadian Easy Built Fairchild Ranger constructed by Lain McQueen, Tokyo, Japan.



17. The 8-inch span miniature of the Super G Shark, complete with scaled spark plug, needle valve, etc., by Bob Fenske.

This was duly recorded in the August Plug Sparks column. This was immediately followed by an irate call from Clarence Bull who in essence said that this writer didn't know the free flight 1/2A Texaco rules.

True enough! A telephone call to Jim Adams, the new SAM president, revealed that the free flight 1/2A Texaco Event, as developed by the Southern California clubs, allowed about anything including the use of .020-size engines.

So, hopefully this retraction should mollify all ruffled feelings. With different rules and classifications for R/C and F/F O/T events, it is no real problem to get confused. Sorry 'bout that!

#### FREE PLUG DEPARTMENT

Received a most interesting telephone call from Russ "Jessie" James, proprietor of the A-J Free Flight Service, 4840 E. Leisure, Fresno, California 93727, who announces he will be producing the Advanced Hurricane 69, a design by Arleigh Armstrong.

The marketing of this kit with reprints of the original plan will be priced at \$49.95 with a postage and handling charge of \$2.50 plus California sales tax where applicable.

For those unaware of this design, Armstrong produced a reduced version of Goldberg's Sailplane as manufactured by Comet Model Supply. The Hurricane wing is practically the same as the Sailplane with about ten inches of the center section removed. The fuselage has been simplified being fully rounded built on the crutch system.

*Continued on page 98*

#### Old Timer of the Month

Design by: Joe Weathers

Drawn by: Al Novotnik

Text by: Bill Northrop

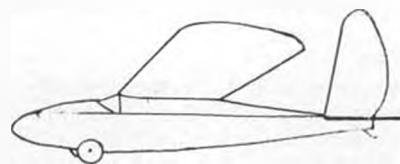

## Classy Class "C" Glider

• The name Elbert J. Weathers always rings a bell of familiarity with old time Old Timer modelers. Best known for his many published gas model designs that never failed to jump out of the rut that was current at the time, he also had that rare talent of coming up with unusual, but always practical and very functional rubber and glider designs.

Actually, this writer doesn't recall at the moment any other glider design by the late Joe Weathers than the one we are presenting this month, but this one has long been etched in our mind, since it first appeared in the August 1939 issue of *Flying Aces* magazine. Even for 1939 it was an unusual design for a glider, with its boxy fuselage, low aspect ratio wing, a huge rudder that would seem to be able to cause some spiral stability problems (but apparently didn't), and of all things...wheels yet...two of 'em...one on each side!

But the thing about this glider (*Flying Aces* called it "Classy Class 'C' Glider") that captured the imagination was the story of

its escapades, as described in the article.

*This glider, designed and built in 1933, has since been duplicated by me four times. You see, "fly away" losses have kept me busy making new copies of this sweet little job.*

*Unofficial flights made to date have been clocked at 21, 28, and 33 minutes, respectively...all after launching with the regulation 100-foot towline. On the 33-minute hop, the ship "thermaled" to a breathtaking high altitude over San Diego, then landed later on the floor of a service station. In making that sit-down, believe it or not, the ship flew through the 36-inch width open doorway with its 30-inch span!*

*On another occasion, the model flew out of sight over Mission Bay (which was largely nothing more than desolate sand bars back in those days). I thought it was lost, but an obliging citizen eventually notified yours truly as to its whereabouts.*

*Continued on page 100*





# ALL ABOUT ARFS

By ART STEINBERG

• Vector as defined by Webster: "The particular course followed or to be followed, as by an aircraft; compass heading — to guide (a pilot, aircraft, missile, etc.) by means of a vector sent by radio." What a highly appropriate name for a radio controlled model, for this is what Carl Goldberg Models calls their latest offering. As a drastic departure from their usual line of high quality kits, the Vector is a variety of ARF, an almost-ready-to-cover model. The manufacturer refers to it as a "40-size sport trainer," listing its specifications as 59-inch wingspan, wing area of 630 square inches, with a ready-to-fly weight of 5-1/4 to 5-1/2 pounds. The Vector requires a 4-channel radio, and is recommended for .35 to .45 2-cycle or .45 to .61 4-cycle engines.

As I have mentioned previously, I try not to allow myself to be swayed or impressed by fancy cartons which are designed to sell the product inside. I usually don't even like to comment on such things. However, in this case, Goldberg is to be congratulated on a really outstanding piece of artwork. The picture on the box label is so realistic that the Vector seems to be three-dimensional, and the color rendition is so lifelike that it could be framed as an extremely attractive wall decoration.

Now to check the contents. Nice! A completely framed up model, ready for final assembly and covering. I ran my hand over the balsa surfaces and couldn't help but feel a pang or two of envy. My thoughts drifted back to the many hours I had spent in sanding and in attempting to achieve such a flawlessly smooth exterior on all the countless models I had constructed. While I do enjoy cutting, fitting, and joining wood, sanding absolutely leaves me cold. After years of getting balsa dust all over the place, I finally came up with the idea of doing all my sanding outdoors, and even then only when there was a breeze blowing away from all structures and vehicles. Since most of my building time was limited to evenings, this didn't work out too well. Anyway, I gave the matter a great deal of thought, and I am now prepared to divulge my top-secret procedure for sanitary sanding. Quite simply, I stripped off my clothes, stepped into the shower (water turned off) with the model, closed the shower door, and sanded to my heart's content. When I finished, I brushed off the model, put it outside the shower, and rinsed myself down thoroughly. When I stepped out, everything was clean as a whistle, including me. I never tried doing this with quarter-scale models, but I guess it will have to depend on the size of the individual shower to which you have access.

Anyway, the Vector requires no sanding

whatsoever, so there is no appreciable delay in getting to the fascinating part. Interestingly, the fuselage and tail surfaces are balsa and what appears to be an excellent grade of light plywood. The horizontal stabilizer is of built-up framework construction, while the vertical fin is of solid balsa. The wing is a marvel of balsa-sheathed foam, so precisely done that I couldn't find a defect in it anywhere, right up to the smoothly-finished balsa wingtips. No shortcuts appear to have been taken with the

Vector, no plastic parts, just good old honest hand-built components! As a matter of fact, I challenge anyone to detect the fact that this model was prefabricated just by examination. It should be regarded as a conventionally constructed model in every way, except that the manufacturer does most of the work. At this point I had every confidence that when it came to flying, the performance would be as good as possible within the limits of the design parameters, and there would be no loss of performance due to use of heavier materials such as is often encountered in ordinary ARFs. Goodness knows why, but a full-size drawing is included, showing every facet of the radio installation and the control surfaces in complete detail. This plan-sized diagram alone should be sufficiently informative to enable the average modeler to assemble the Vector. However, Goldberg has seen fit to supply a twenty page instruction manual which is really a primer for the beginning R/C modeler and pilot. Besides assembly and

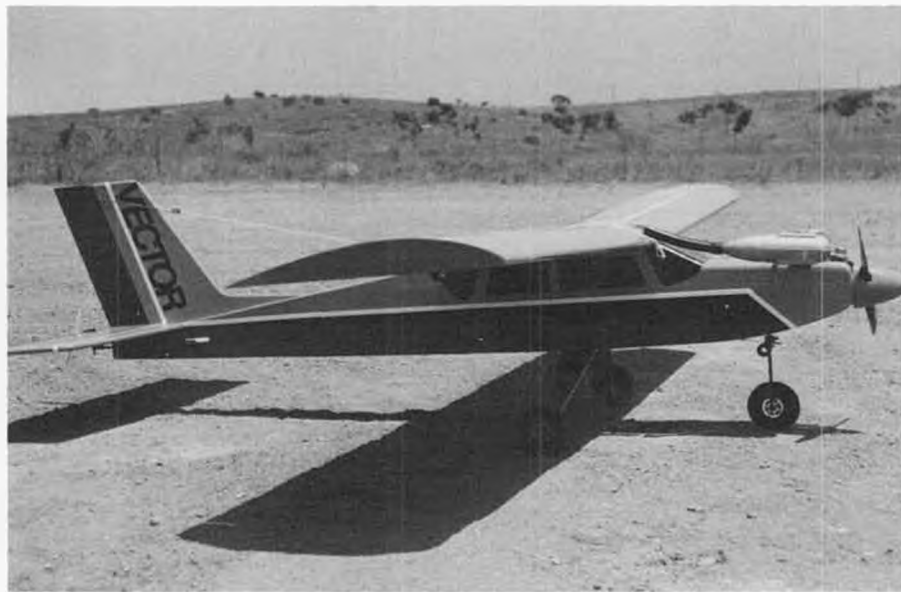

The Goldberg Vector up close. Note the clean lines and flat-bottomed airfoil. The neoprene muffler extension keeps exhaust residue from under the wing.

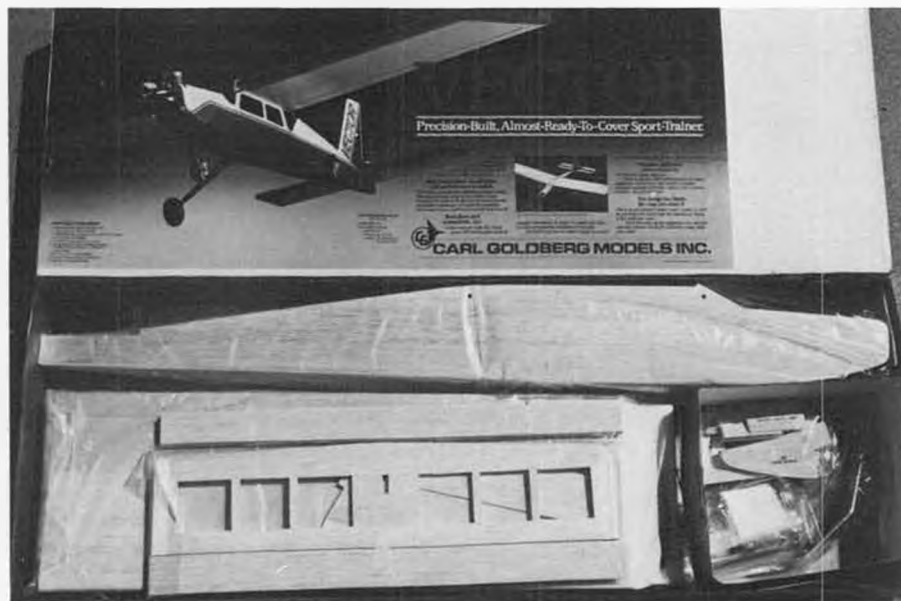

Compactly packed in a colorful box, all that is required is a little light assembly and your favorite covering material, and you're ready to fly!

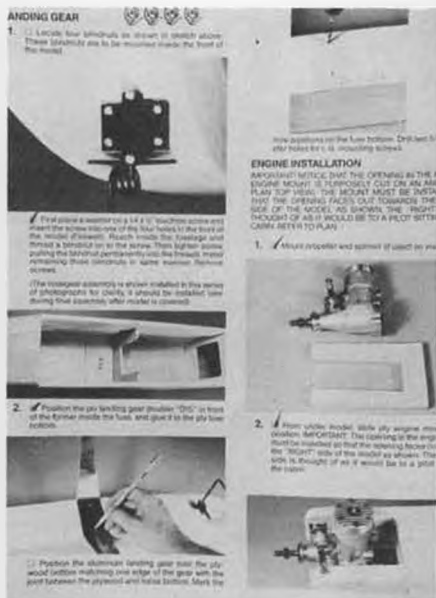

A sample of the excellent instructions included with the model. Each step is demonstrated with a sharp photo or drawing.

finishing information, additional topics are discussed minutely. For example, selecting radio equipment, choice of engines, propellers and fuel tanks are all taken into consideration. Of course, painstaking step-by-step directions are provided for absolutely each and every aspect of assembly, complete with little boxes in which to check off each procedure as it is completed. Instructions on covering are precisely given, and much is said about the radio installation. Even a discourse on where to fly your model, on checking your radio, and the basics of flying are all in the manual. I wish every beginner could read and digest this little booklet, as it would probably clear up quite a few mysteries. Right here I am going to enter into a discussion of one of my pet peeves and state my only criticism of this outstanding set of instructions. While the manufacturer practically implores the newcomer to do everything in his power to obtain a flight instructor, he finally makes the usual concession as follows: "And only if there is no other way open should you attempt to learn on your own." Directions are then given which are supposed to be helpful in unassistedly learning to fly an R/C model. Perhaps such instructions would

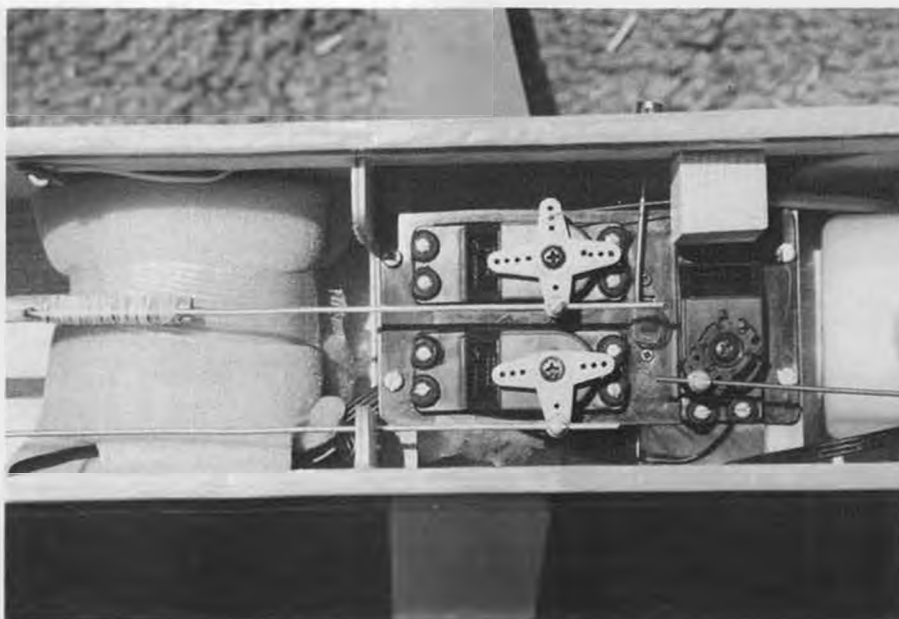

The spacious fuselage easily accommodates any modern radio gear, as well as virtually any size fuel tank.



Author with his Vector just before its first flight.

suffice for a sailplane, but certainly not for a sport model with a .40 engine and capable of moving at dangerous speeds. I don't think even being out in a field in the middle of nowhere by one's self should promote such experimentation. It is far too dangerous,

even if it can result in injury only to the novice handling the controls. Besides, we know that even skilled flyers should make it a practice to never fly alone. Now I'll probably get deluged by letters from readers telling about how easily they taught themselves to fly, but I must confess I know a number of people who have done that very thing. However, I am adamant on this point. If you don't have an instructor teaching you then the odds against learning R/C piloting are heavily stacked against you. I believe that those who have some kind of model flying experience such as a free flight background stand a far better chance of teaching themselves to fly than a rank newcomer to the model aviation hobby. Enough about that complaint, so let's get back to our subject, the Carl Goldberg Vector.

Actual assembly and covering was given over to a member of my panel of modelers, Bob (Jet Jockey) Hill. According to Bob, assembly went quite smoothly, and every step in the manual was followed implicitly. No problems were encountered, and the only time a bit of real attention was required was in joining the two wing panels. These were

*Continued on page 78*



On a test flight from the author's favorite paved runway, the Vector entertains spectators with a low, slow flyby.



The Vector taking off from a dirt field. Stability in flight contributes to effortless takeoffs and landings.

# MODEL DESIGN & TECHNICAL STUFF

By FRANCIS REYNOLDS



• This novice columnist is now entering phase two of his indoctrination. Until recently, this effort has been strictly monologue. I was writing columns each month but getting no feedback because of the long time between writing, publication, and reader response. Now your letters are coming in, so I know it hasn't all been in vain. But readers' letters are moments of truth. It is a bit like the difference between acting in the movies versus acting to a live audience. On the other hand, you may be live, but the months of flow time between my writing and the publication of my comments on your comments on my writing are a far cry from face to face dialog. So be it.

First, a correction: In MD&TS for July a phrase was omitted at the bottom left corner of page 104. It should say that the airplane CG should be between 10 and 18 percent of the total fuselage length ahead of the balance point (center of lateral area), on the scale cardboard cutout, for proper directional stability.

Next, a little reader feedback on the July column: Jack Cockerham tells me that the free flighters have used a formula relating tail moment arm and wing span, which he believes they called "tail moment." It appears that some modelers are confused between "moment" and "moment arm," perhaps including said free flighters. I know I read an article in one of the magazines some time ago where the writer had moments and moment arms screwed up. So let's unscrew things.

A "moment arm" is simply the length of a lever, such as a crank arm or throw, a control arm or horn, or a human arm, which is, of course, a lever. Moment arm is measured in inches, feet, or meters. Moment, on the other hand, is a moment arm times a force, so it is measured in ounce inches, pound feet, etc. Moment and torque are really the same thing. When we are talking about structures and levers, which rotate little if at all, we speak of moment. If the subject is an engine, a servo, or a rubber motor, we speak of torque. Both words mean twisting, bending, or rotary force. Webster says, "the measure of tendency to produce motion about an axis." The horizontal tail moment of an airplane in flight is therefore the tail moment arm multiplied by the load on the horizontal tail. This moment has to balance the moment of the weight times the dis-

tance between the CG and the center of lift and the pitching moment of the wing, in order to stabilize the airplane in pitch.

Speaking of letters, when you write and want a personal reply, please include a SASE (self-addressed, stamped envelope). The correspondence with readers becomes a very time-consuming activity for writers of columns such as this. If you can get your answers from your flying buddies, I would appreciate it, but where my opinions are needed, I will do my best. On the other hand, your contributions to the column are more than welcome, and your letters let me know what you are interested in and at what range of technical levels I need to write. Incidentally, when you write, don't assume that I will be familiar with your particular airplane by name; I probably won't. Always give me all the data I may need to try to come up with the answer you seek.

Regarding cube loading, which I addressed in September: Joe Wagner, who writes "Small Steps" in *Model Airplane News*, gave me some more history on the subject. He says that Ron St. Jean wrote an article, "Wing Loading is Three-Dimensional," which appeared in the August 1959 *Model Airplane News*. Ted Off wrote on the

subject in *Radio Control Modeler*, and Dave Platt addressed it in *RCM* in both August and December 1974, calling it "cubic wing loading." I also learned, after my September column went to press, that Joe Wagner himself wrote about volume loading recently in *Model Airplane News*. With all of these fine modelers agreeing on the concept, it must be the way to go.

I continue to get data on CuLs and RPFs for various airplanes and models. I'll wait another month or two before I compile and publish them. Send your inputs soon.

## CRINKLE CRINKLE LITTLE SPAR

I stole that heading from Darrol Stinton in his book, "The Design of the Airplane." (I don't know who he stole it from.) It will serve to introduce the subject of airplane strength. The strength requirements of the wing spar to resist wing bending loads in flight is probably the most obvious need for strength in an airplane, and we will cover it briefly, along with many more subtle strength needs.

*Continued on page 88*



An experiment by the author in crash-damage elimination.

# R/C SOARING

By BILL FORREY

• Apologies to all who went looking for R/C Soaring last month and didn't find it. A combination of a lack of magazine space, the necessity of including the more time-critical Astro Champs article which I wrote last month, and the fact that I missed the deadline for submitting the regular column all contributed to its omission. Hopefully, this will be the first and last time since I came on as the R/C Soaring editor in 1982 that I will skip an issue! To make up for it, this month's column is a real monster, chock full of all kinds of stuff, so enjoy!

Readers who have been with me more than four years now may recall seeing the accompanying photos of a very small and highly maneuverable slope glider called the Skywalker. I first mentioned it in my March 1984 column, and from that first mention have received many letters of inquiry, some as recent as only a few months ago. Because many of you out there on the slopes keep digging up this article and asking questions about the model, I feel that it would be worthwhile to run it again, this time with a miniature "construction" article as a bonus.

To bring you up to speed on the Skywalker, let's take a look back at the original review:

Just in case you think I'm making this up, I've included photos of what I think is the most fascinating little slope glider I've ever seen. The gentleman you see holding this little gem is Dick Vader—no, not Darth Vader and no, he is no relation to George Lucas. The glider is called the Skywalker. Yes, the name was taken from the "Star Wars" epic, but the name was given to the glider by Dick's friends at the slope, he had nothing to do with its choice. It was a name that just simply stuck!

I became acquainted with this design soon after moving to Costa Mesa, California (that was in 1982). Terry Troxel, who literally lives (he moved too!) a stone's throw from the slope overlooking the Santa Ana River, was first to show me its abilities, and his own. I couldn't believe my eyes. There wasn't anything this little aerobatic slope ship couldn't do, and it could do it all in a mere puff of wind on a short section of cliff.

Close inspection of the Skywalker design

reveals its simplicity. I believe its wingspan is 50 inches (52 including optional vortex tips), and its root chord is about five (oops, it is really six!). The wing is carved from solid balsa sheeting into a thin, highly cambered airfoil. Jack Chambers (an aerodynamicist) is credited with the design of the seven- or eight-percent thick section. The



Terry Troxel launches his Skywalker on the slope above the Santa Ana River.



Skywalker designer Dick Vader flies slalom through the weeds.



Dick Vader has successfully designed and flown two versions of the Skywalker, this 50-inch and a 30-inch design.

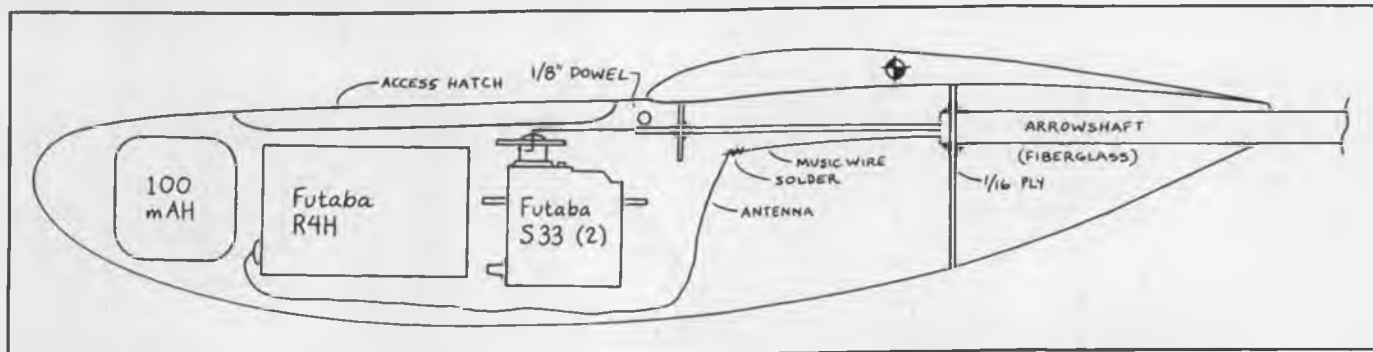

# SKYWALKER 50

High Performance Slope Ship  
Designed By Dick Vader

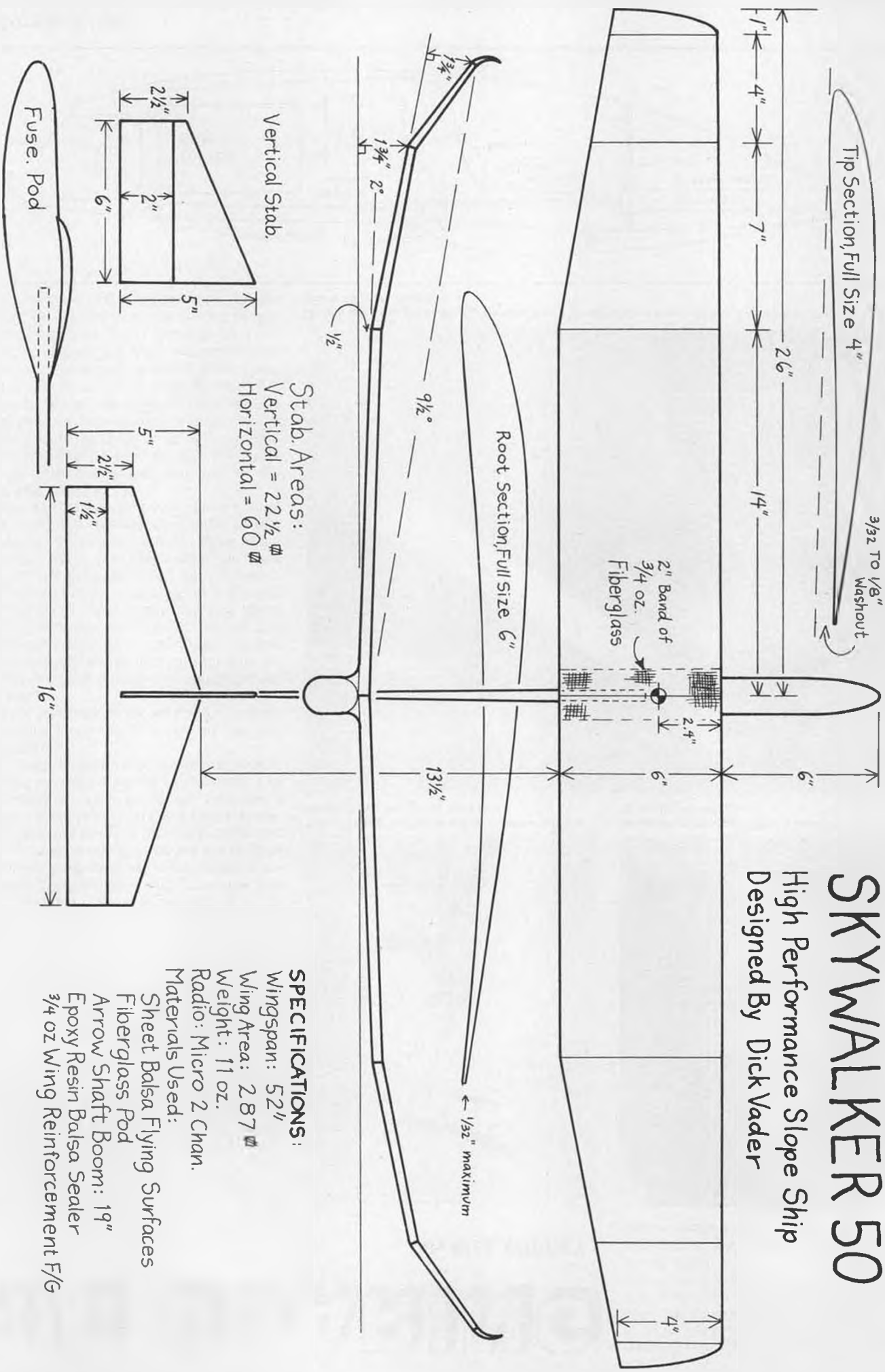

## SPECIFICATIONS:

- Wingspan: 52"
- Wing Area: 287 sq in
- Weight: 11 oz.
- Radio: Micro 2 Chan.
- Materials Used:
  - Sheet Balsa Flying Surfaces
  - Fiberglass Pod
  - Arrow Shaft Boom: 19"
  - Epoxy Resin Balsa Sealer
  - 3/4 oz Wing Reinforcement F/G



Culpepper Models' Chuperosa 59-inch polyhedral or aileron sailplane kit. Nice and very complete.

carved and sanded wing is then joined and reinforced with fiberglass cloth and epoxy resin in the center, and merely resined everywhere else sans F/G cloth. Believe it or not, there is enough strength imparted by the resin alone to allow the Skywalker to be one tough customer.

Breaks in the wing caused by crashes are very easy to repair: just pick up the pieces and five-minute epoxy them together again. You could even use the thick CA glues for these repairs. I've seen some pretty ratty-looking Skywalkers, and they just seemed to fly better with age.

The fuselage on these critters are of the pod and boom variety. The pod is fashioned out of foam and fiberglass. The foam is hollowed out for the two-channel receiver and micro servos. A 100 mAh battery pack does the energizing from way up in the nose. The boom is a fiberglass arrow shaft.

The tail surfaces are shaped from 1/8-inch light sheet balsa and are likewise shaped and coated with epoxy resin. Cellophane tape hinges are used for simplicity and lightness.

My overall impression of the Skywalker is that it is a small, lightweight, knockabout, leave-it-in-the-car type of glider that you wouldn't hesitate to fly at any slope you might find while on your way to anywhere in your car. You wouldn't fear breaking it (it repairs too easily), you wouldn't fear weak lift (you can throw a Skywalker high enough that you almost don't need any), and you can always expect to be challenged by this model's near limitless agility. Like John Dyal said earlier (in the original article), "Having fun is good for you." The original Skywalker section ended with a paragraph about Dick Vader making ready-to-fly models for a fee. Well, that was just not practical for him to do on any scale above just his flying buddies at the slope, it also proved very expensive and required the loan of the complete radio system for the custom radio installation, not very attractive to long-distance business.

Well, from a not-too-recent telephone conversation that I had with Dick, I learned a few more details about building Skywalkers. I also came into a three-view of the plane from the *Model Builder* office which had dimensions for me to work from. I redrew the three-view, included the airfoils at full size, and included a few extra details

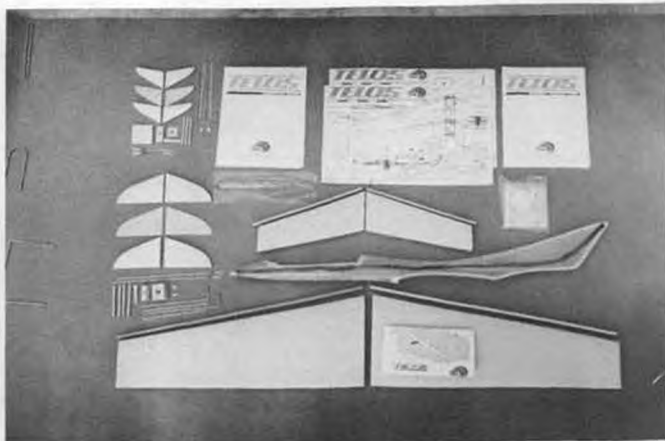

Jade Telos canard kit. Kit now includes balsa wing skins. Hi-tech design and materials make it a futuristic model.

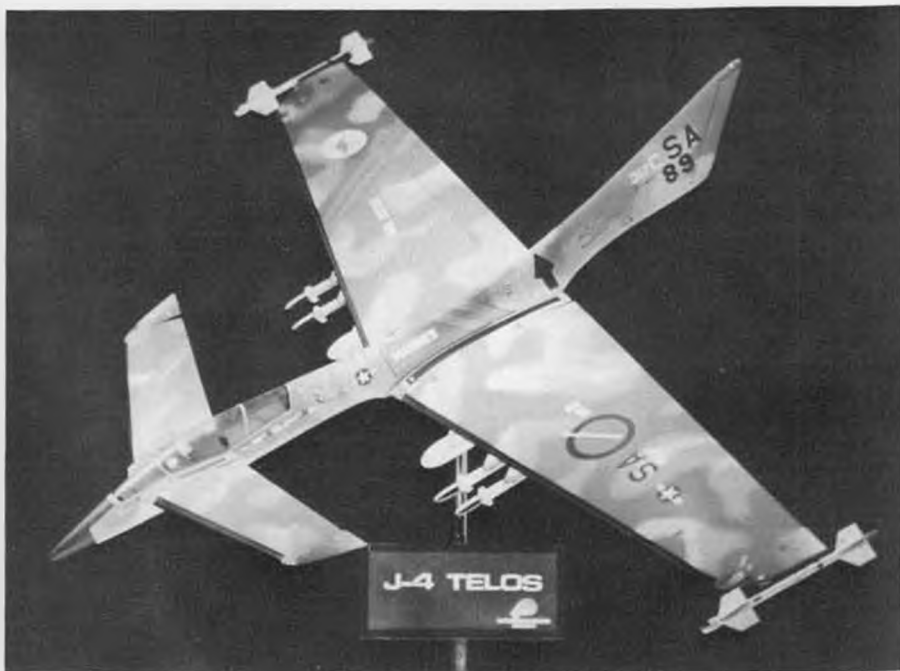

The Telos in military decoration. Richard Jarel is a graphic designer and good with a paint brush.



The Chuperosa in its finished form. See text.

and notes which now make it possible for you to make up a Skywalker yourself, if you should so desire.

First you will need to make a pair of templates of the JC airfoil from a sheet of .020-inch aluminum or brass (available from the

K&S supplies rack at your hobby shop). Do this by photocopying the two airfoils from the three-view at 100 percent. With this copy you will make three templates (two identical six-inch and one four-inch). Cut out the airfoils from your photocopy. Use



Mike Bame and his MB 253515 model for the Princeton wind tunnel.

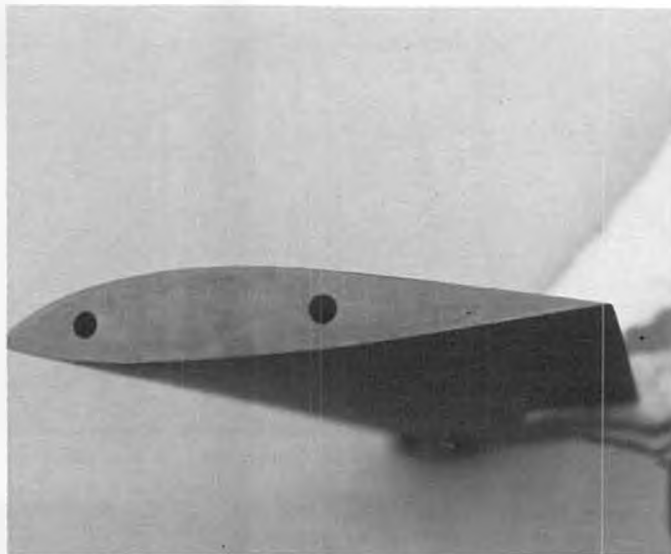

End view of MB's test model shows tubes which are needed for hold-downs in the tunnel.

some 3-M 77 Spray adhesive (or similar) to stick each airfoil drawing to the metal. By whatever means you have (i.e., hack saw, band saw, files, etc.) cut and shape the templates right down to the lines and smooth them with 400-grit paper. You can stack-sand the two identical six-inch templates to assure their accuracy.

You will need three long, flat sanding tools, such as the 22-inch Tee-Bar from your local hobby shop, some spray adhesive, and three grades of sand paper: coarse, medium and fine. Cut the sand paper to fit the tools and apply with the spray adhesive. We are going to use these tools to shape our wings out of the sheet stock. A razor plane will also be handy to use, but not essential.

The wings are made from two sheets of 1/2- x 6- x 36-inch light balsa. The entire constant chord wing center panel may be made from one 36-inch sheet in two pieces (2 x 14 inches). Cut each panel 14 inches long. Sand the four end-grain edges smoothly with as near to a 90-degree edge as possible, use 400-grit. Very sparingly, tack glue the two 6-inch templates to the ends of one 14-inch panel using a thick CA. Use the coarse sandpaper (and maybe even a razor plane, but be careful not to over do it) to rough shape the top surface's contour, then progress to the medium, and finally fine grade papers to sand all the way down to actually touching the templates. Don't



Mark Nankivil and Gary Meissner with their Muller Thermal Kings from Germany.

grind into the templates or they will be ruined! If it looks like the templates are moving relative to the wood, increase the tack glue points. This is similar to cutting a foam core, but the sanding blocks replace the cutting wire, and when you are finished, there is no core bed left over.

Flip the panel over. Carefully repeat the previous sand-down procedure. Make sure

you sand over a flat surface so that you are always pressing directly over the line where the curved top surface is touching the workbench. The airfoil is pretty thin towards the trailing edge, and therefore fragile. Also, make sure the workbench doesn't have a rough surface or wood particles lying on it which will make a bad impression on your finished top surface.

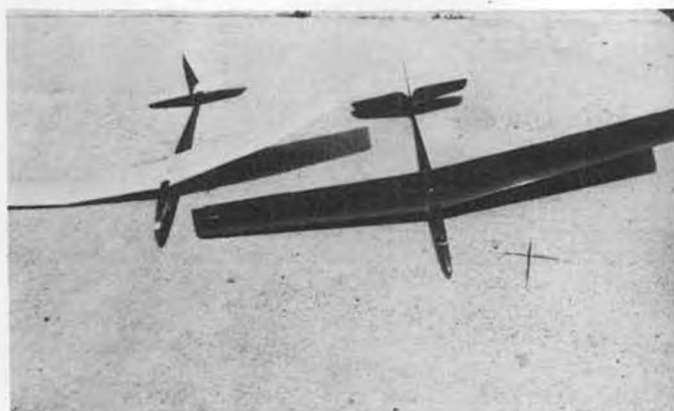

Two versions of the Chuperosa are possible from the kit: aileron/V-dihedral or R/E/ polyhedral. Foam core E214 wings.

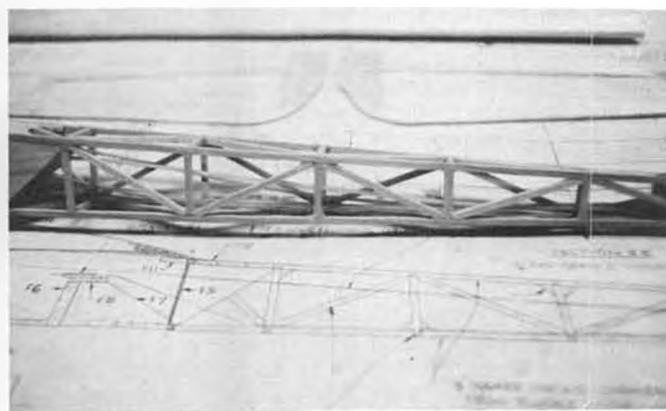

Unusual tail boom structure of the Chuperosa, reminiscent of OT designs.



When you are done with this panel, separate the templates from the wood (you may need to use CA solvent), and do the other center panel. With both center panels done, place them end to end, mark the ends where they touch as "center," and bevel these ends two degrees for the two-degree dihedral per side (four total). The other ends will be the polyhedral break and will need to be beveled about four degrees.

The four tip panels are constructed in the same manner. The two tapered tip panels on each side are constant taper; because of this we can make two at once and split them apart afterwards. Note that the leading edge is straight and the trailing edge sweeps forward. When you make your top-view cuts from the 1/2-x 6-x 36-inch stock, make sure you make a left and a right wing tip panel, and label each as "TOP R" or "TOP L" so that you won't accidentally make two rights or two lefts. Label the leading edge also to keep from making backwards airfoils. Finally, note that there is 3/32 to 1/8 inch of washout in each tip and that it is sanded into the wing. Raise each tip template's TE this amount before tack gluing it to the tip, then draw a reference line for the new trailing edge, and begin to sand.

When both tip panels are shaped, cut each into two separate panels where indicated on the three-view. Bevel the root edges four degrees and the edges at the separation cut thirteen degrees each.

Begin with the inner panels and assemble the wing working towards the tips. Always be careful not to twist in any warps while assembling the panels. The main panels are joined together with the poly breaks propped up 1/2 inch on each side. Leaving the main panels propped up 1/2 inch, glue the inner tip panels on each end while propping them up 1-3/4 inches from the workbench. Finally, lay the wing down flat on one inner tip panel at a time and glue on the outer tip panels propped up 1-3/4 inches. Be careful not to accidentally negate the washout in the outer tip panels by misaligning them the opposite way. If you like, at this time you may add the optional wingtip blocks and carve and sand them into an upwardly curved shape.

Once the wing is assembled, you may reinforce the center joint with a two-inch strip of 3/4-ounce fiberglass cloth, top and bottom. Use thinned epoxy resin. Once this step is done, and before the epoxy begins to gel, continue painting the thinned epoxy over the entire wing. Allow the epoxy plenty of time to harden. When hardened, finish sand the wing with 400- and 600-grit paper. The wing is done.

The fuselage is made from either one (white) or preferably two-ounce density (blue) polystyrene foam. You will get a smoother surface with less resin soak from using the blue foam which is a homogeneous mass of open foam cells. Blue foam is also easier to shape. White foam will chunk out beads of foam and get fuzzy when you sand it. You can work with white foam, but it is not fun.

Begin by laying out your radio gear on a flat surface and tracing the individual com-

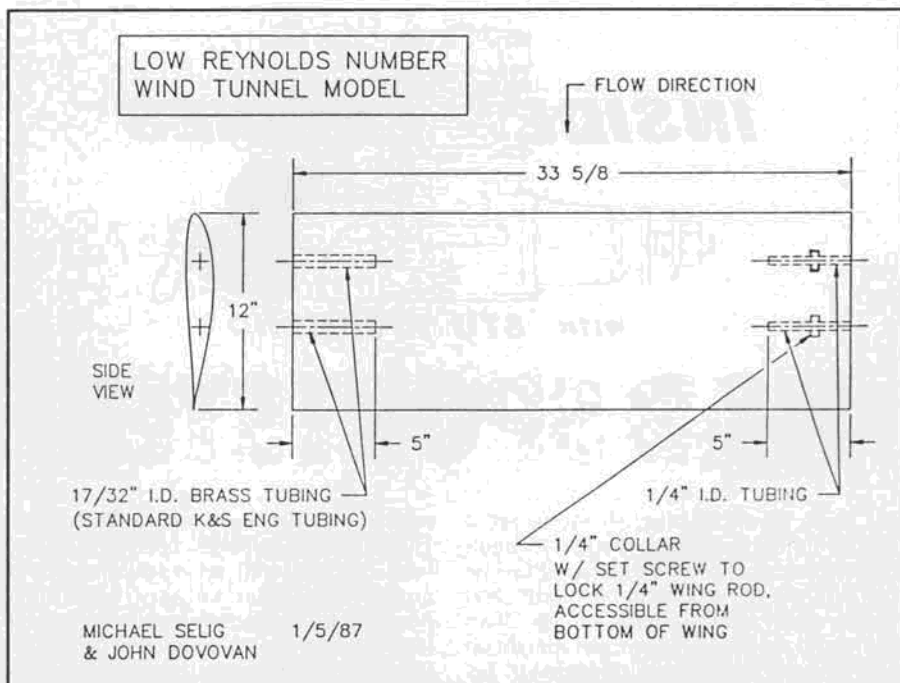

Models being tested in wind tunnel are built to these dimensions.

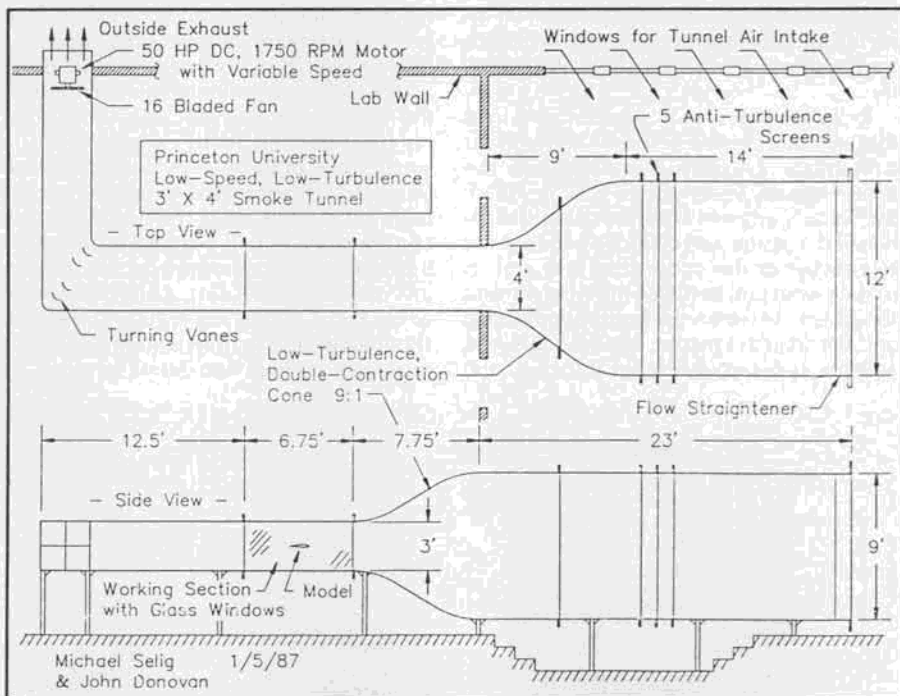

Schematic of Princeton's wind tunnel.

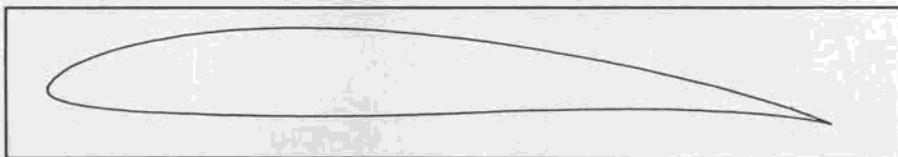

Eppler 214 airfoil, an example of a "modern" airfoil profile.

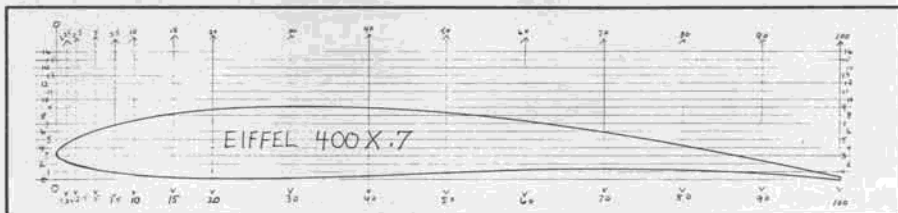

Tom Matterfis' thinned out old airfoil for comparison.

Continued on page 100

# INSIDE ENGINES

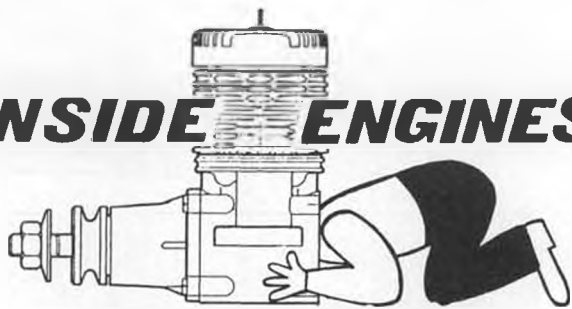

WITH **STU RICHMOND**

## K&B SPORTSTER

• I think it's an absolute shame to see a model builder buy a new modern technology engine, a gallon of the cheapest fuel he can buy, put the engine in his model, and then see how *fast* the engine will go. Often he'll point the nose of the model straight up and lean the needle until "meltdown" begins. Often he'll lean the engine on the ground until it starts to sag with internal heat-caused expansions that yield metal-to-metal unlubricated frictions; then he'll back the needle valve out a few clicks and start to fly.

Today's engines have average flying lives that are considerably below 15 air/hours for a multitude of reasons. The above common actions greatly lessen the 15-hour probability! Today's engines have precision fits between the piston and cylinder, between the top socket of the connecting rod and its mating wrist pin, between the wrist pin and the piston, between the bottom rod socket and the shaft's crankpin, between the shaft and the housing/casting, in the carb, and

even more places in four-cycle engines. These mating surfaces need a low-load heat-up cycle with an overabundance of quality lubrication for very brief initial items (15 to 30 seconds ideally at first) followed by a normal cooldown before the heat-up cycle is again repeated, over and over for longer and longer times, until maybe 30 to 60 minutes of running is reached. This time is called "break-in" and every new engine *deserves* break-in with a quality fuel. If an ounce of castor oil is added to the first gallon of fuel run through the new engine, it's even better. Most good hobby shops sell small cans of castor; a small bottle of Baker's AA from your local pharmacy is better than none! All model fuels are *not* the same; the lubricants vary considerably. K & B Manufacturing offers the best engine guarantee available. But unless their engines' *first* gallon of fuel is either K & B 500 or K & B 100+, I feel they should have the right to *void* their *lifetime* guarantee on their Sportsters! So much for

the soapbox; let's look at the .65 R/C Sportster.

When engines are designed to run at say, 12,000 rpm and lower, their physical requirements are far different than if they are designed to run at 15,000 rpm and higher. The average Sunday sport flier is in the 12,000 and downward range normally.

America's K & B Manufacturing has aimed their new Sportster line of engines at the Sunday flier with great success. Using new ideas takes courage. K & B has a totally new concept in design and manufacture—at very attractive pricing—and we're the winners. While some overseas manufacturers are using softer, less expensive nickel plating on their cylinders instead of hard chrome, K & B has chosen to chrome the *pistons* of the Sportsters. The piston has less surface than the cylinder, so the total plating cost is less and the chrome is superior. Additionally, K & B is using an extremely hard aluminum alloy for their castings. So the new .65 Sportster has chrome running in aluminum for their piston/cylinder. The crankshaft rides directly in the aluminum alloy rather than in expensive ball bearings or a bronze bushing. The greatest design feature is the cylinder-and-cooling-fins-with-exhaust-outlet casting which is all one piece of cast metal with CNC internal machining! Inexpensive model engines were made like this in the 1940s before modern metallurgy existed and before the sophisticated CNC machinery that enables internal cylinder tapering, and before chrome plating. They were called "slag" engines and featured aluminum pistons running in aluminum cylinders. In 1987 Australia's engine expert, Gordon Burford, looked over the Sportster design and smilingly said, "This is America's slag engine from the 1940s that is brilliantly made in the 1980s; wonderful!" When you first handle a .65 you'll notice the combustion chamber seals as soon as the piston rises to close the exhaust port (there are no piston rings in the Sportsters). When you put a prop on the engine and flip it over, you may/will hear the engine *squeak* as the piston goes through top dead center. *This is normal*. You may even feel that the piston is binding in the cylinder as it goes through top dead center. *This is normal*. The use of CNC machinery allows a slight diminishing of the cylinder's inside diameter up towards the cylinder head. As the piston rises into this diminished taper it fits tight and forms a superior seal against combustion gases to yield more power. Many non-ringed Super Tigre, Rossi, Como, and other engines are machined like this. The tightness is metal-to-metal; it changes as the engine heats up to operating temperature somewhat.

But if the fuel you've bought for this new engine contains lubrication with inadequate film strength; heads, you lose and tails, you *also* lose! It'll never get to 15 hours of probable running and you won't get your money's worth.

Mechanical teardown was interesting. A dual pinch rod locks the carburetor in place; others will copy. The carb's true measure of greatness is the useable speed range that it yields. We all need the slowest possible reliable idle to make easy landing ap-

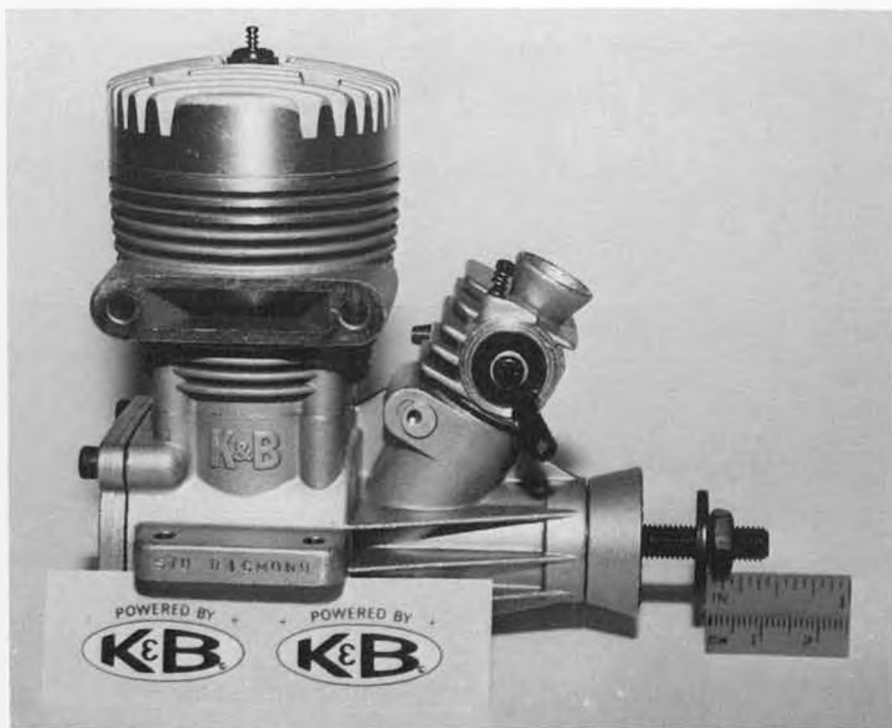

K&B's latest .65-size Sportster includes the most generous guarantee. Engine is cloned from their .20 and .45 sizes and may be joined by a still larger version. The .65 Sportster is made in the USA and is a viable alternative to the much higher priced imported 4-stroke engines.

proaches. The carb is easy to set per instructions and has a .340-inch inside throat diameter. All three sizes of the Sportsters share a common spraybar assembly. You can pull a spraybar right out of a .20 Sportster and press it in the .65 Sportster. The two "O" rings fit into slight detents in the carb casting; simple, economical, and effective! The two "O" rings form a critically positioned fuel reservoir much like a Perry carb does. The .65's muffler outlet inside diameter is .350-inch, same as Fox .40 Standard. Exhaust timing is a conservative 146 degrees. The five bypass or transfer ports are cast into the cylinder. The large one sweeps across the piston top with incoming fuel/air mix. The remaining four aim their mix away from the exhaust port. Conservative exhaust timing and K&B's port design result in unusually fine fuel economy. A six-ounce tank yielded consistent ten- to eleven-minute flights in an Ugly Stik. The bottom CNC surface of the cylinder head mates with the top CNC surface of the cylinder.

The cylinder head has a .600-inch diameter single bubble that is .250 inch high. The squish band around the bubble is .165 inch wide. The deck height (distance from top of piston to bottom of cylinder head at T.D.C.) measured .048 inch, which indicated the engine was designed for easy no-kick-back starting which proved to be correct. Cylinder bore measures .930 inch at top and piston's stroke measures .937 inch for .64 cubic inch displacement. (My .20 Sportster actually measures to be a .21.) As exhaust timing approaches 140 degrees, fuel economy tends to increase. As timing approaches 160 degrees, unburnt fuel tends to blow out the exhaust and be wasted. As timing approaches 180 degrees (seldom seen on model engines) much unburned fuel passes out the exhaust, and the supercharging effects of a tuned pipe are best realized as this fuel/air mix gets rammed back into the cylinder just before the piston raises to close the exhaust. The .65 Sportster proved very non-temperamental; it's a beautiful sport engine.

The total reciprocating/rotating weight of the piston/rod/wrist pin and Teflon pad is only 21 grams (28 grams/ounce). The .210-inch diameter steel wrist pin dead ends into the piston from the rear; there's a hole all the way through the piston, so only a single



Engine has about 60 parts, including clever auxilliary "spider" mount in top right corner for firewall mounting. Crankshaft's disc is .415 inches thick and contributes to excellent idle performance through its rotating mass. The muffler is the most effective to date.

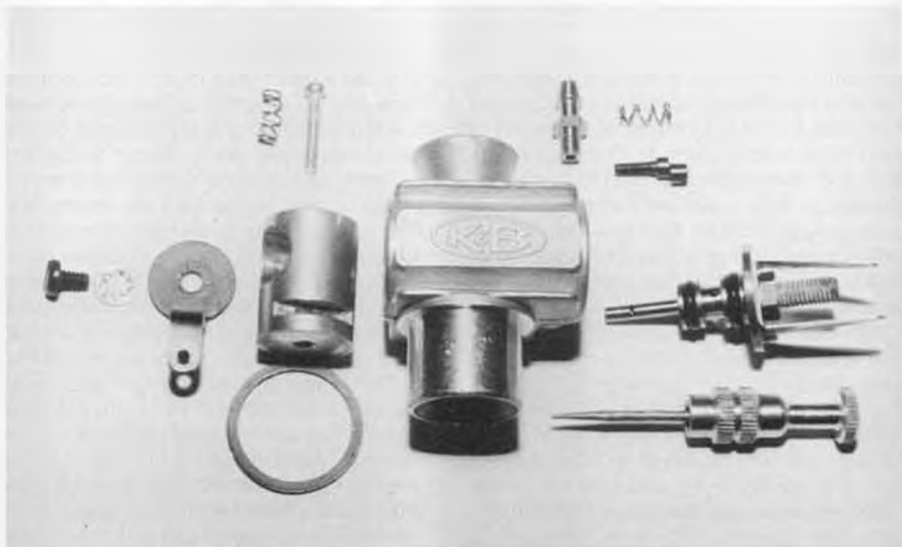

The Sportster's spray bar assembly (pictured above needle valve) simply pulls out of the carburetor casting for easy cleaning or crash damage replacement. Spray bar's two "O" rings fit into detents in casting to form tiny fuel reservoir. Bolt above bar is for idle speed adjustment.

Teflon pad is needed at the rear to separate the steel pin from the cylinder wall. The top of the piston measure about .001 inch bigger diameter than the top of the cylinder diameter; this is the source of the tight/

squeaky sound for which some inexperienced modelers have returned new engines to various manufacturers or vendors!

*Continued on page 85*

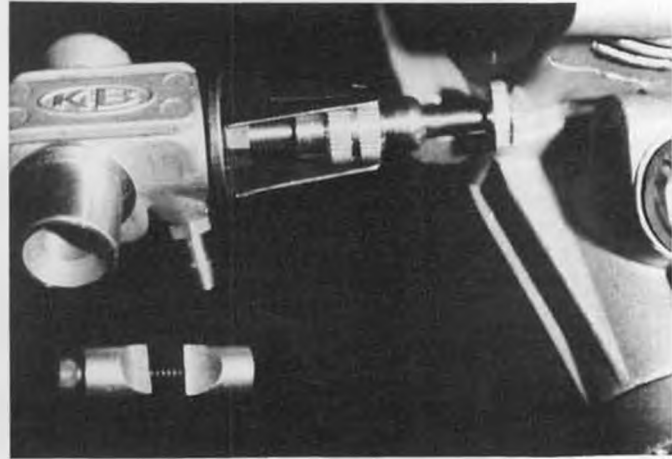

Dual pinch rods (lower left) are drawn together by a single 4-40 bolt to lock carb body in position. Simple idea is sure to be copied.

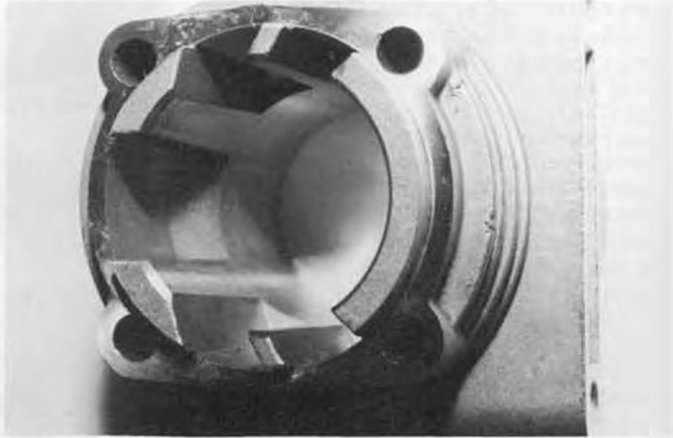

Bottom view of cylinder with exhaust stack to right, showing K&B's unique five port bypass design. Main port directs fuel mix across top of piston. Four auxilliary ports direct mix away from exhaust stack.

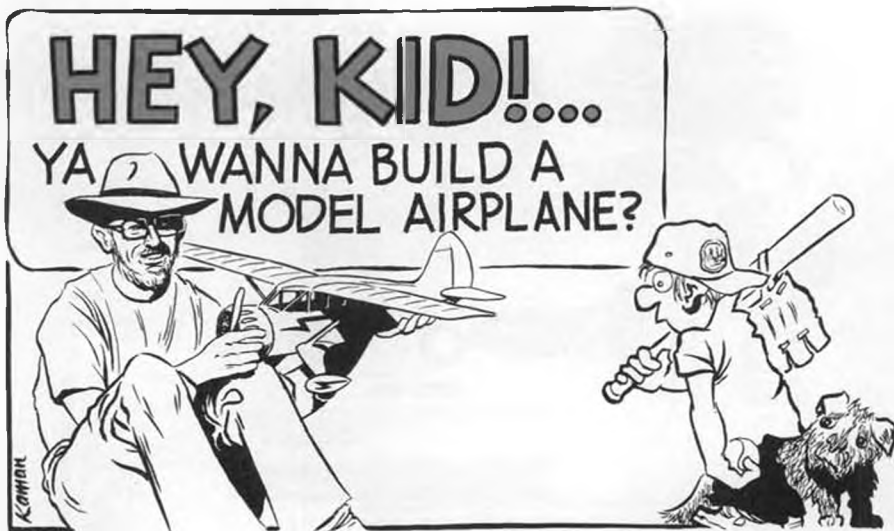

By BILL WARNER

Illustrations by JIM KAMAN

- Just got back from flying the test models I made for this series, and you'll be happy to note that they all flew great! I Xerox-reduced the plans to 16 inches and made a little one, too, that flies nicely indoors or out. Got over two minutes on it a couple of times. All in all, I think you're going to love your Moth. *But*, don't ever expect a model to fly right off the board. That's why we started this series with simple models that you could learn adjustment techniques on. The bigger ones follow the same rules, but are just harder to repair!

#### CARVING A PROP

If you built the long-nosed version, I think you would do well to carve a propeller. Everyone should do that at least once in a lifetime. If you decide never to do it again, at least you will have had to think through how a propeller works and how it is made.

There are several features which identify a prop or "airscrew." The most obvious is its diameter; how big it is. The next feature is how wide each blade is, which helps determine its "blade area." Next, how deep the blade is determines its "pitch." Pitch is like angle of attack (alpha) on a wing. The more angle, the more "bite" the prop will take with each turn. When you view the prop looking at the tip, you can see that on a plastic prop the angle is less at the tip than it is at the hub or blade root. That is because the tip spins faster around the circle and therefore can produce a lot of thrust with less angle of attack (pitch). The pitch angle gets larger and larger as it goes toward the slower-spinning center of the prop. This is called "helical" pitch, as the path the blades follow as they pull the model forward through the air is what is known as a "helix." If you just stuck two flat blades to the hub with no twist to them at all, you would have a rather inefficient airscrew with the same angle all the way out to the tip.

If you just took a block of balsa and started whittling away, the results would probably be pretty sad. Makers of duck decoys say that they just take a block of wood and whittle away anything that doesn't look like a duck. That's okay because they know

what a duck looks like. Many people who fly models really never looked that closely at their propellers. Besides, all a duck decoy has to do is float when it's finished. Your airscrew has to operate at something near maximum efficiency to give you the kind of performance you want. Plastic propellers are pretty well worked out and have only a couple of drawbacks: they are heavy (and often out of balance) and they are usually too small, as they come in kits. If you make a light model and want a little bigger prop to wind down the turns you packed into the rubber motor more slowly, you may want to carve your own. Balsa props are not all that hard to carve if you know what a prop looks like and if you start with a "blank." A prop "blank" has the general outlines of the finished prop cut into it already. All you have to do is connect the leading edge (edge you'd contact with your finger winding normally or clockwise) with the trailing edge (edge closest the front of the model). The best way to get a feel for what you are going to be carving away is to study a plastic

prop carefully. The main difference is that the plastic prop is smaller in the hub or center area. If you made your balsa prop that small there, it would break too easily.

I use a special knife ground from a hacksaw blade for carving props. The edge is very thin and takes a great edge, as the toothed part of the blade is very hard. The rest of the blade is not hardened as much and is very tough and flexible. You can use a regular pocket knife, but it should be sharp. If you do not have a whetstone, lay a piece of 400-grit "wet-or-dry" abrasive paper flat on the edge of a table and "strop" your knife blade back and forth on it, with the blade almost down flat but not quite and moving away from, not toward, the sharp edge. Do the same thing on a piece of leather belt to finish the job. A little oil on the paper and a little jeweler's rouge on the belt will help, but are not absolutely essential.

When you do start carving, keep a plastic propeller right by your side for reference. Cut small chunks off, and, if the wood starts splitting ahead of your blade, you should turn the prop end-for-end and cut in the other direction where the grain is working for you, not against you. One place where many beginners screw up is in carving one blade right and the other blade upside down. If you check your plastic prop, you will notice that the front side of the blade has a radius, curved, or cambered surface facing forward. Now, if you turn it around so the other blade is in the same position as the one you just inspected, you will notice that it looks *exactly* like the other one, and that the camber is still facing in the same direction, forward. You would not believe how many kids I have seen carve the second blade facing in the opposite direction!

I suggest doing the front of each blade first, and then flipping it over to the back sides (face) of the prop. The front has a little camber or curvature to it from L.E. to T.E., but the face has either no camber at all (flat) or a slight undercamber or concave (hollowed) surface. Use a straight edge on it and you will see that it rocks on the front surface



Long-nosed version of the Moth using carved balsa blank from Oldtime Modeler Supply to keep the nose light.

and shows a little light through in the center of the face. When you have carved the face portion of the prop to within about 3/16 inch to 1/8 inch of the front surface, you can start working on it with your sanding block. On the back side, making a curved sanding block or wrapping some sandpaper around a curved object will make the work easier. Finish the prop with 400-grit paper and give it a couple of coats of sealer (dope mixed with baby powder), sanding between coats. It will come out smooth as a baby's rear end, ready for a coat of colored dope of enamel.

The center, or hub, of the prop will require a little special attention, with the addition of a little plywood inset into the back side for strength and to prevent the bead or washers you will use to take up the rearward pull of the rubber from pushing into the balsa on a crash. Around the center where the prop shaft comes through in front, rough up the surface of a short 1/4-inch diameter aluminum tube and twist it in a little ways and epoxy it solidly. You can glue it in with your Testor's "green tube" cement, but don't put it on too heavily, and use several coats, allowing it to dry well in between. One of the secrets of making models is not to rush things, and always have something else to work on while glue or paint dries thoroughly. When it is well set in, examine the "wolf's tooth" freewheeling ramp molded into the center of your plastic prop. Notice where the shoulder is and which direction the shoulder faces. It has to be right for the spinning prop shaft to shove in the direction of the L.E. of the prop. Now comes the tricky part. I make a cut using a Zona saw (fine-toothed thin hacksaw for wood and soft metals) where the shoulder will be and then file away at it until I have a spiral ramp which the bent-over prop shaft can ride up on when the prop is windmilling after the power has run down. Allowing the prop to free-wheel in this way cuts drag and does not mess up the glide as much as a prop which just stops in one position. This ramp can be cut with a knife, as aluminum is sif, but remember to be extra careful and *never cut towards meat (you)!*

#### STUFFING THE MOTOR

There are many creative ways to get the rubber motor into the model and hooked up to the rear peg. Some kids tie a string on it with a weight and drop it into the nose and pull the motor down where they can worry the rear peg through it that way. I prefer a stuffer-stick. This is just a length of dowel or any stick with a couple of side-plates glued on the end to hold the end of the rubber motor spread apart enough so that you can get the peg through easily when its inserted into the model. I have one made from something that looks like a telescoping car antenna with a couple bits of brass sheet soldered on the end to spread the rubber loop. Fits easily in the ol' toolbox. Make sure it's long enough, though.

#### BRAIDING A MOTOR

One of the things the rubber motor in models loves to do is to bunch up in a big heavy knot all the way back in the fuselage when the motor is unwound. This is because the front, near the propeller, unwinds



David Rosenstein from the author's Aeronautics class at Paul Revere Jr. High does some test piloting on the long-nosed version of the Moth.

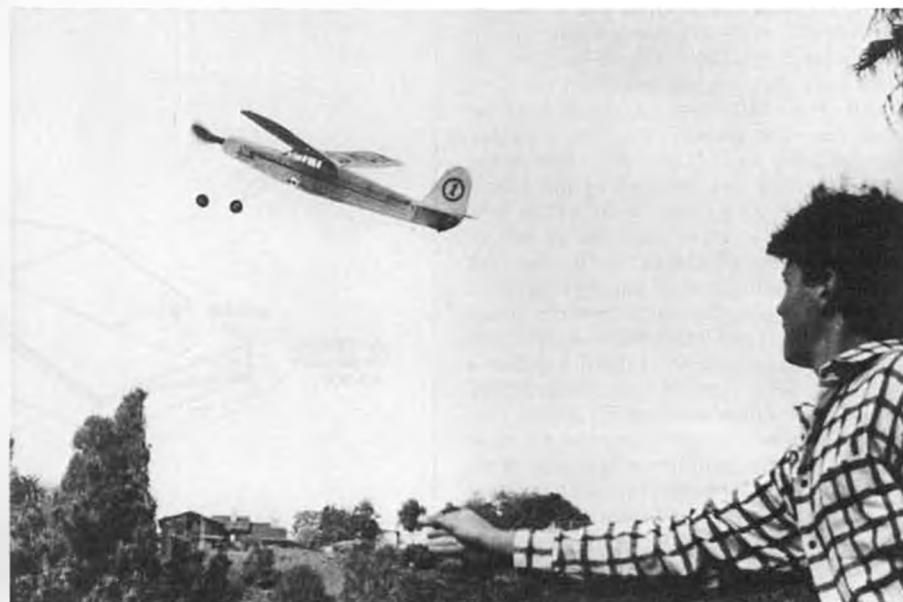

There she goes! The Moth climbs right out of David's hand in this at-the-moment-of-launch shot.



The FAC Moth in flight! Flights like this are risky on days when there are thermals, as the Moth can fly away all too easily. Light your D.T. if you installed one!



Balsa props can be balanced by sanding the heavy blade or giving the light blade extra coats of dope. Prop will stop in a horizontal position when balanced. Allow dope to dry, as wet dope is heavier.

first. Of course, this usually makes the plane tail-heavy and puts it into a stall. To prevent this, make a two-loop rubber motor and braid it. You can use three loops of 1/8-inch later after you get tested out with two loops about 1-1/2 times the length from the motor hook to the rear peg. Have your helper hold the model, and loop one of the loops coming out the front of the model around a finger to keep it out of the way. Then, give the other loop about ten or twelve cranks clockwise with your 5:1 winder. Loop the wound loop over another finger and repeat the operation with the unwound loop. Then, hook both wound loops on the winder and wind them together a few turns. When you let them unwind, they will braid themselves together just as nice as pie. You will have to experiment a bit to get just the right number of braiding winds for your particular motor, but you'll find that it will keep your motor from knotting up. Don't use more turns than you have to, and always wind clockwise for all of the above operations.

#### WINDING IN A TUBE

Packing the winds in a rubber motor when you are "going for broke" can be heartbreaking if the motor does break. There you are standing there with an exploded fuselage and some wise guy will always say, "Why don't ya' back off one turn?" Would if I could. Well, why not avoid that kind of embarrassment and insert a tube into your model while winding and let the rubber explode in that instead of your model?

Clear plastic tubing can be purchased in an aquarium store, and you should get the largest size that will fit in the front of your model. I got some tough plastic "shrink tubing" at an electronics surplus store that works well and is lighter than the aquarium tubing. In a pinch, you can roll your own. I have one I made years ago out of some thin mylar drawing plastic bound around with tape that works just fine. The tube should be just about an inch longer than the distance from the nose to the rear motor peg.

Winding the motor in the tube is easy, the problem is how to get the tube out! A piece of .045-inch music wire with an eye on one

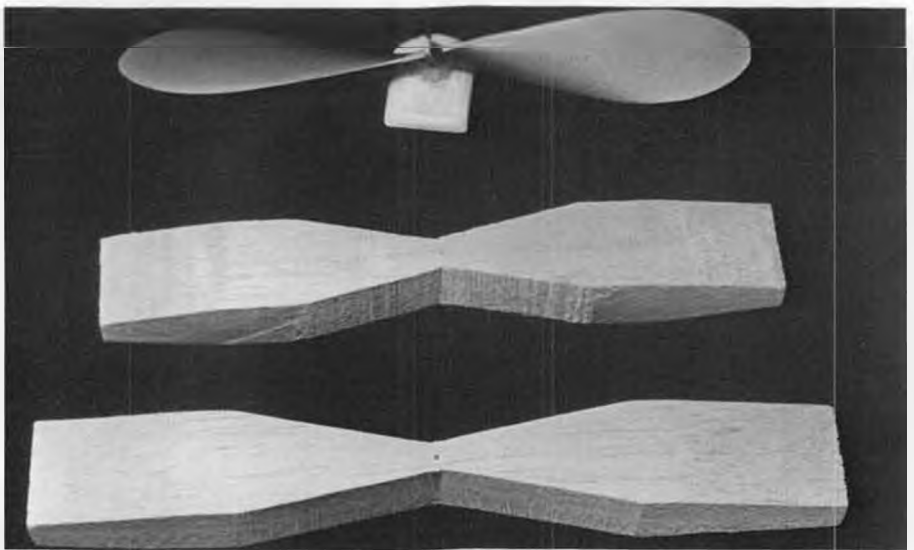

The stock plastic prop (top) compared with the 8-inch and 9-inch balsa prop blanks available from Old Timer Model Supply.

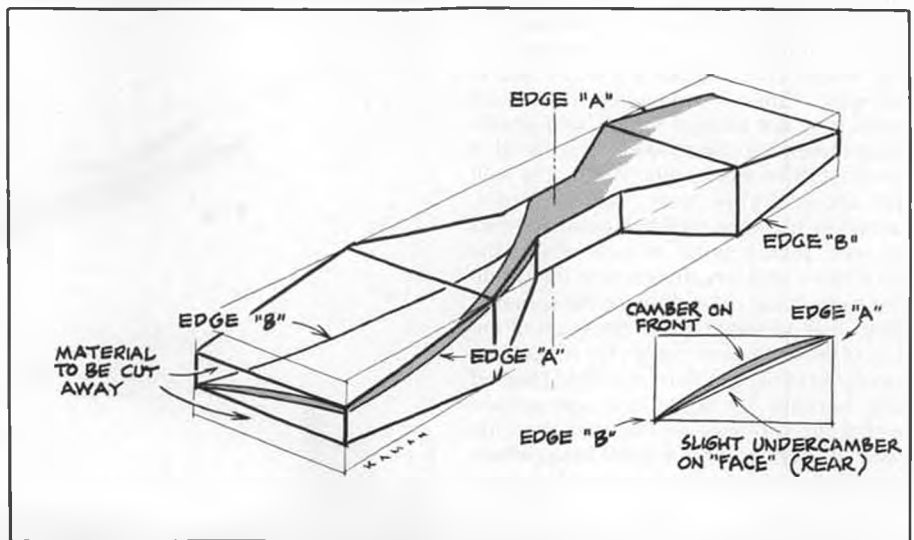

The secret of carving a prop from a balsa blank is to stay away from edges "A" and "B" and let them determine angles carved into the prop. Keep a plastic prop handy for reference while carving your wooden propeller.

#### ADDING A FREE-WHEEL CAPABILITY TO YOUR PROP -

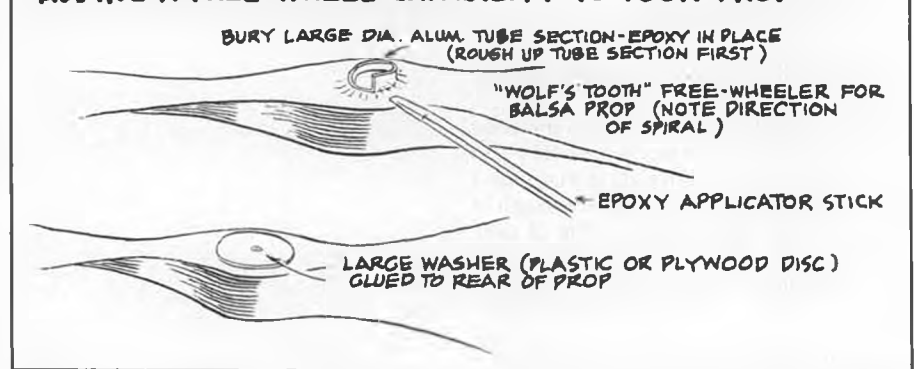

end and a hook on the other just a little longer than the winding tube is what you need. Start with one end hooked on your 5:1 Peck winder and slide the tube over the wire. Then hook the rubber end on the winding wire, shove the tube all the way in, and have your helper hold the works while you fearlessly crank in the turns (not too many for test flights!). When you are wound

up, pull the tube back out and over your winding wire, grab the end of the rubber, back off a few turns, unhook, and you are ready to hook on the regular front end. If you don't let go of the lubricated rubber, you'll be okay! Experts have other ways of doing this, with little specially bent hooks that stay attached to the rubber and which make handling easier when you shove a

heavy piece of stiff wire through to help hold it while you hook up to the prop shaft on the nose block.

### FLIGHT TRIMMING

There is one thing to remember when you trim for flight: You do it backwards! The first part of your flight is the *powered* part, and the second phase is the *glide*. However, the glide part is what you have to get right *first!* The glide is controlled by the angle of attack of the wing, which can be changed either by moving the center of gravity by adding modeling clay to the nose or tail, by raising the L.E. or the T.E. of the wing, or by raising or lowering the T.E. of the stab. On the power phase of the flight, you have to contend with increased speed, which makes small wing or tail twists much more effective. So much more effective that a twist that might not even have been noticed in the glide may take over at high speed and roll you into the ground! You also must contend with the twisting force or torque of the spinning prop. I assume that you have mastered the flight adjusting techniques required for the Sleek Streak, the Peck R.O.G., and the Sky Bunny mentioned in previous episodes, and that all you need to do now is apply them to a more complicated situation.

The CG on the FAC Moth will almost certainly be too far forward due to the long nose, even if you have shortened it a bit as I showed you earlier. Adding a bit of modeling clay to the tailskid is probably going to solve the problem. Balance the model with the main spar of the wing (1-3/8 inch back of the L.E.). Wind the motor and let it run down first to see where it will lie. If it leaves a knotted-up hunk of rubber in the tail, you will need to add a few more braiding turns to pull out that extra slack. Then balance with clay. Do not move the CG again unless all other adjustments do not seem to work.

De-warp the model over steam before going to the field and, at that time, twist in about .050 inch to .070 inch wash-in in the left wing (less than the thickness of a nickel). You will need this to hold the left wing up in the left power turn.

Test glide over the tallest grass you can find with about a hundred turns in the motor, just enough to keep the prop from pulling ahead or holding you back. Point the nose slightly downward and give it a shove to get it up to flying speed. If you don't push too hard and it is stalling each time, try adding about 1/32 inch of balsa sheet under the T.E. of the wing where it crosses the fuselage to decrease the angle of attack. If the model repeatedly dives, do it to the L.E. This is very hard to do right, and the only time you'll really get a chance to see what your glide is like is when the motor runs down at 100 feet of altitude. Still, you have to start somewhere.

Cautiously add a few more turns, maybe 250 or so, and try a low-powered test flight. Consult your adjusting chart (page 51, May 1988 *Model Builder*) to see what changes need to be made. Your goal now is to get the model high enough to check the glide, and once you have the glide down (mine glided left in about 70-foot circles), then add more power each flight and continue to make minor adjustments.

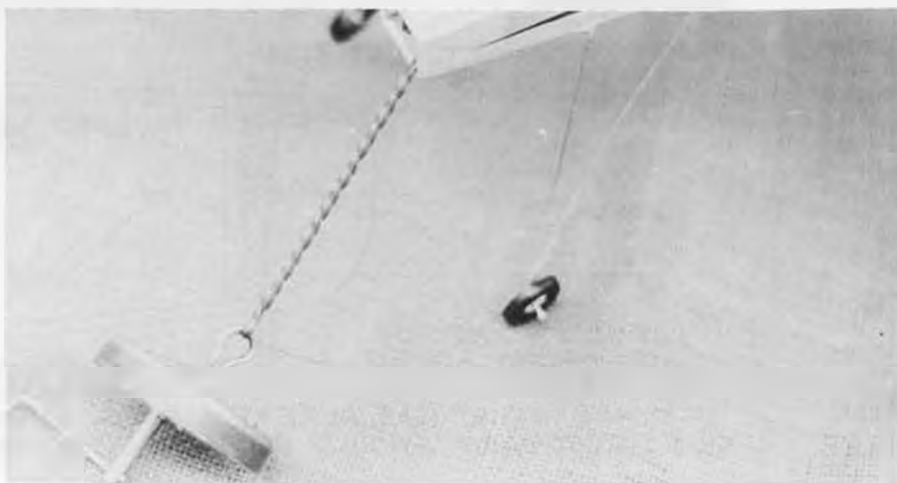
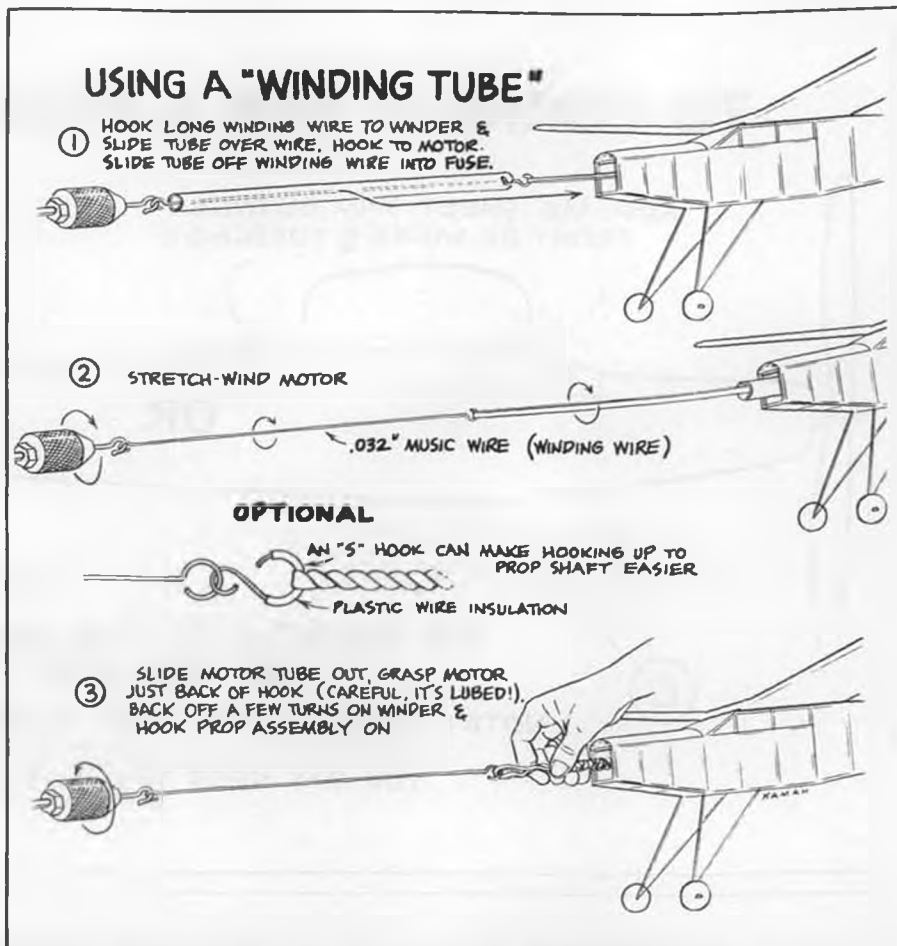

Step one in braiding a motor: put a few winds in one loop, hold, do the same with the other loop. Connect the winder to them both and wind them together.



A braided motor helps control rubber bunching in the tail and the C.G. shift and stall that results. Details in text.

## TO CORRECT FOR A DIVE...

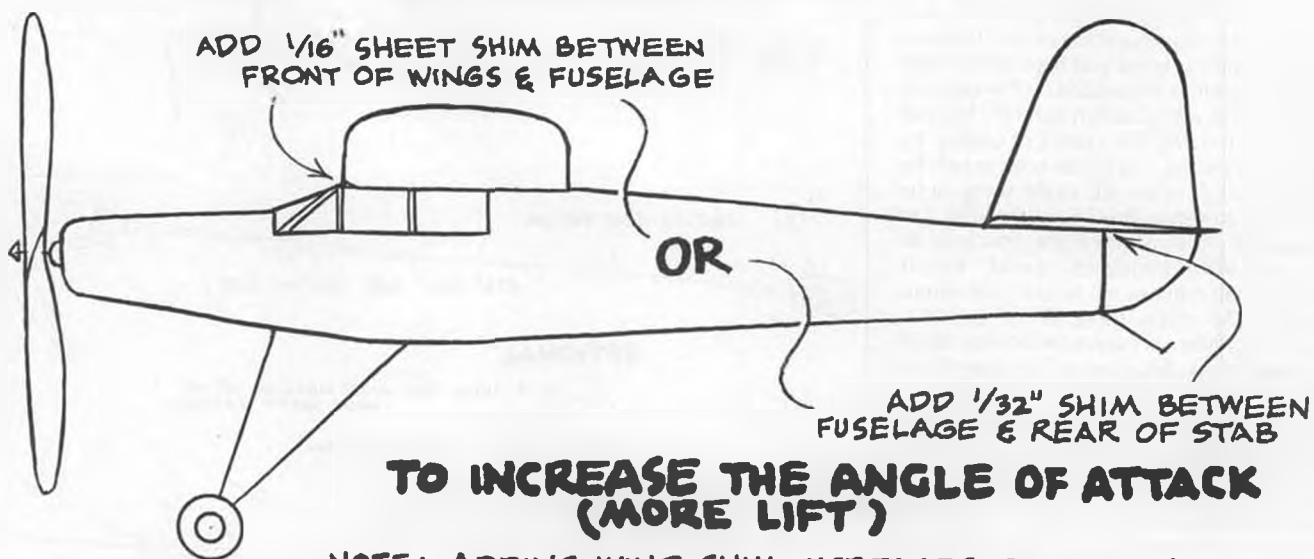

NOTE: ADDING WING SHIM INCREASES DOWNTHRUST AUTOMATICALLY - SO IF YOU'VE ADDED ANY, YOU MAY NEED TO CUT IT DOWN.

## ADDING RIGHT & DOWNTHRUST

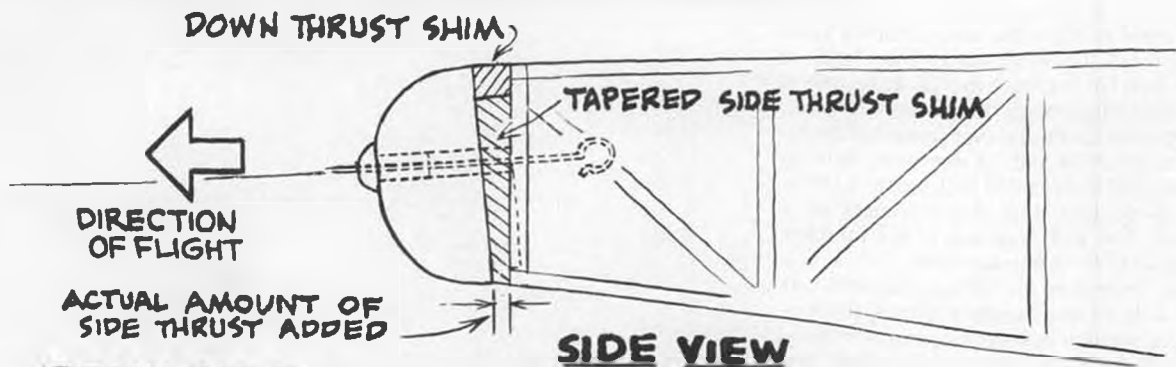

IF DOWN THRUST HAS ALREADY BEEN ADDED, THE SIDE THRUST SHIM SHOULD BE TAPERED AS SHOWN

## ADDING RIGHT THRUST

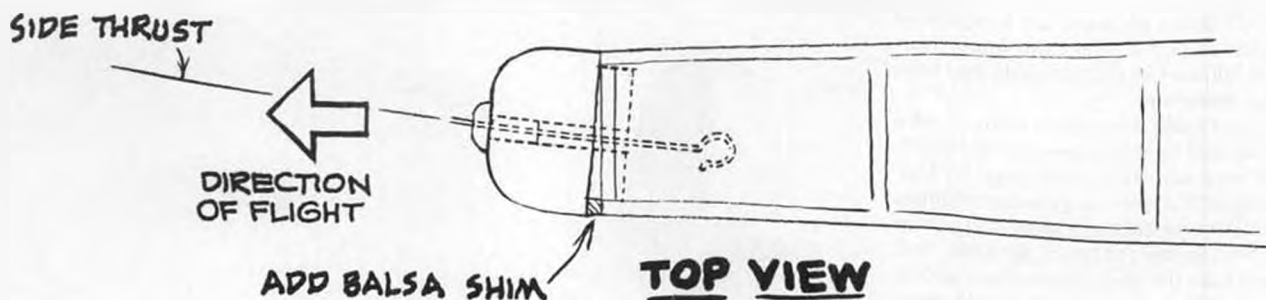



## THRUST ADJUSTMENTS

Once the glide is good, then you can work on the power pattern, which is controlled by aiming the propeller in exactly the right direction. If the model turns too sharply to the left under power but glides okay (you probably bent in a little left rudder to get the glide circle correct), add a thin balsa shim (about .030 inch between the left front end of the fuselage and the left side of the nose block). This will aim the prop thrust a little to the right and help widen the left turn to make it safer. Add another thickness until it is flying well.

The second thrust adjustment is down-thrust, which involves adding a shim at the top to point the thrust down a little. When the power runs down, the thrust adjustments will have no effect on the flight. They are just for the power phase. Usually a combination of right and down is needed. After gluing the shims on the nose block, you can trim them down to where they contact the front end all along their length using your razor blade. As the nose plug needs to fit snugly into the hole in the front of the fuselage, you may have to add some scrap to deepen the part that fits into the nose so it will stay put. After your model is flying correctly, you can sketch the correct down and right thrust angles on a piece of paper and then remove all shims and change the position of the nose button in the nose block by prying it out and regluing it in at the correct angles. Note: Never use anything soft like modeling clay for shimming. It compresses and will not be of much help in the long run.

## TWO CAUTIONS AND SOME INSURANCE

When you are flying when there are thermals around, use your D.T. When going for max performance, use your winding tube. Finally, make sure you have your phone number and "Reward" on the model if you want it back!

## USING YOUR D.T.

Be sure that the rubber bands pulling the stab up are strong enough and that the key is not hanging up in the fuselage. Then, cut a piece of fuse about an inch long and wet one end in your mouth. Twist it to a point and screw it into the snuffer tube. When you pull the "burn-through" rubber band past the fuse, make sure it touches the fuse. You may have to move the hook it attaches to out away from the fuselage a bit if you can't get it to make good contact. This rubber band should be stretched *tight*. Tie it off if it needs to be shortened. After winding, light the D.T. fuse, being *very careful* not to light your model along with it, and also *do not drop* your match, stick of incense, or whatever into the grass! Be safety-conscious. Actually, an old discarded cigarette lighter (disposable type) will light a fluffed-up fuse end with just sparks.

It is a good idea to carry a pair of pliers in your pocket for putting out the fuse if your model lands early. Easier than snuffing it out with moistened fingers. Fuses that have burned all the way down and are hard to remove can be shoved inside and shaken out the front end.

## A FINAL NOTE ON TRIMMING

Few models fly correctly without lots of

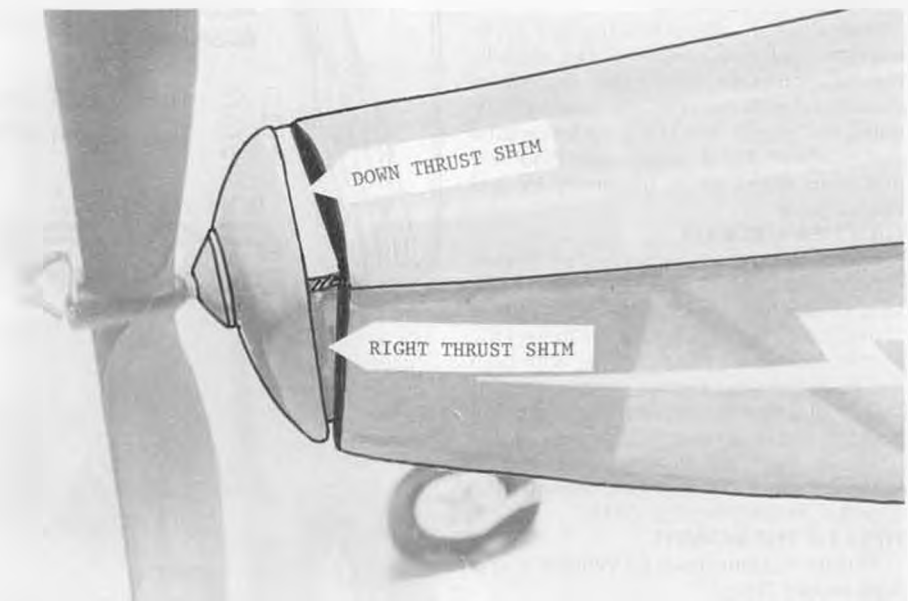
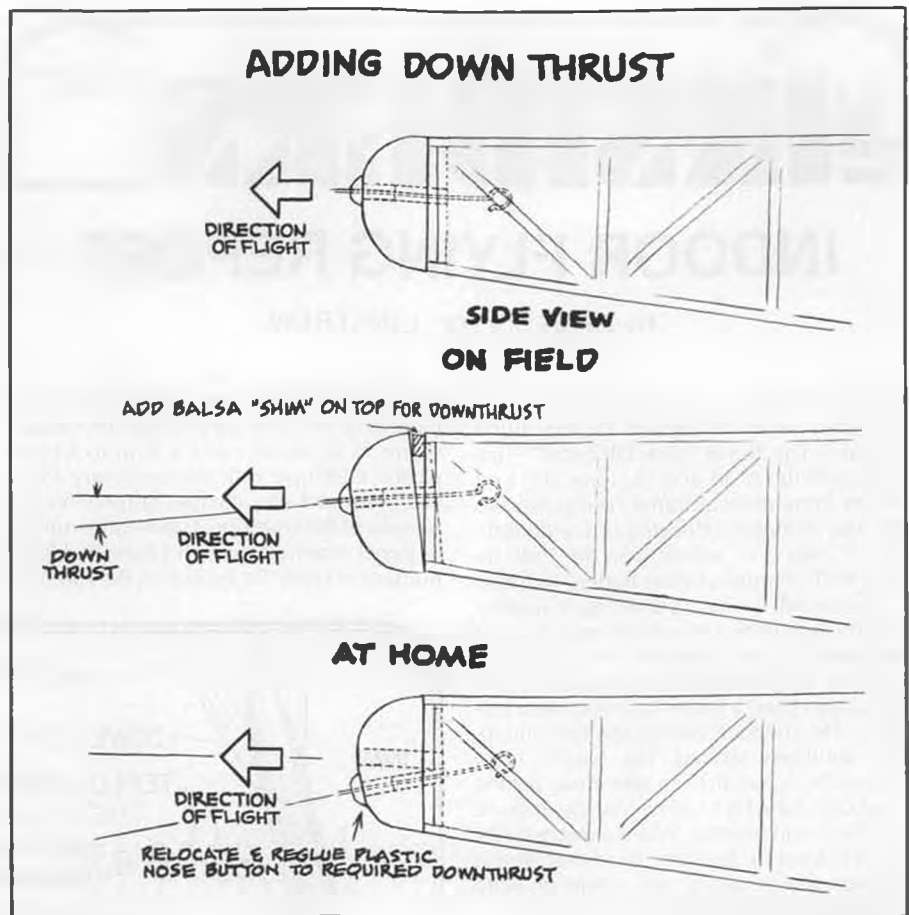

Position of shims added during trimming at the field. Both down and right thrust were needed.

testing. Never re-fly a bad flight without trying to figure out why it did what it did. You will just have to learn to be a keen observer so that you will *note* what it did. Some of the kids in my classes constantly come to me for advice on what needs to be done to make their model fly. In reply to the question, "What did it do?" they reply, "It crashed." Big help. I have known veteran modelers who did the wrong things to their models when under pressure, so don't feel that you are unusual if you make mistakes. It just takes less time if you can remember exactly what your model did. Did the prob-

lem occur during the power or glide phase? If only during the power phase, then you will work with thrust adjustments. If only on glide with a good power pattern, then figure that your thrust adjustments were compensating for a bad glide trim, and you should make adjustments for the glide first and then reset the thrust line which will now be wrong. The glide comes *first* always, then adjust power. Exactly backwards.

A couple of "last resort" trim adjustments you might want to try if your model resists

*Continued on page 92*

# THE INSIDERS

## INDOOR FLYING REPORT

By DAVE "VTO" LINSTRUM



A pair of obscure craft: proxy Doc Martin with Pistachio and Peanut Hosler Fury by Butch Hadland of the United Kingdom.

In the August "Insiders" we began the three-part series by Hewitt Phillips titled "What If The Rules Were Different?" This dealt with the AMA and FAI rules effect on Indoor Endurance airframe configurations. We also featured a drawing of Erv Rodemsky's "Gram Prix" which won the 1980 Indoor F1D Champs at West Baden, Indiana.

This month we have a drawing of another of Erv's designs that was developed at about the same time as Gram Prix. Erv is the originator of the Pennyplane indoor event and has always been a leader in indoor development. He concocts one of the best micro-film solutions around. His witch's brew here is the "Gramlin," an attempt to get the most out of the F1D rules. Note the unusual planform and bracing. Was it a winner? No, but it is food for thought. Read that Hewitt Phillips article again and come up with your far-out original design.

### SO SMOOTH BEARING

Scale fliers are always looking for ways to increase endurance from rubber models. Noseblock friction is one culprit that can be eliminated with the Williams bearing illustrated this month. The key is the teflon tube and washers. Try it—smoooooth! You will find your flight times up on AMA and Peanut Scale.

### OBSCURE AIRCRAFT

There is no reason why obscure aircraft cannot win contests. Witness Butch Hadland's Pistachio Gran Prix winning Hosler "Fury" proxy-flown at Johnson City by Doc Martin. We have a photo of Doc with both the Pistachio and Peanut versions of this odd 1939 British design with a 1:1 aspect ratio wing and long nose. It never flew well in full-scale form but does great in indoor scale. For plans, SASE to Doc Martin, 2180 Tigertail, Miami, Florida 33133.

### HINT OF THE MONTH

This item comes from Ed Whitten's *New York Indoor Times*:

"Recently several writers have commented about the common method we indoor fliers use for storing rubber. I'm talking about the use of paper envelopes, and I'll pass on the comments for your evaluation.

"Rubber strip is shipped from the few suppliers we have in small paper envelopes where it has resided in the cool and dark for who knows how long. I have continued to use these envelopes because they have provided an excellent storage method and also a good place to write comments about motors and experience therewith. Now comes information that chemicals used in the paper-making process are harmful to the rubber and tend to prematurely age it. Sul-

fur seems to be the worst culprit, although there may be a few others. Best procedure seems to be transfer of the strip to a clear plastic envelope with the necessary identification on a slip of paper fastened to the outside of the envelope. I have some rubber in paper envelopes which I have had for a number of years. So, I suppose the rumor is

valid and should be heeded if you plan to store rubber for any purpose for very long. Most suppliers of outdoor rubber strip seem to ship in plastic bags for whatever reason."

### TOOLS AND MATERIALS

Ideally, a modeler's work area should be a table or bench, free of unwanted items and

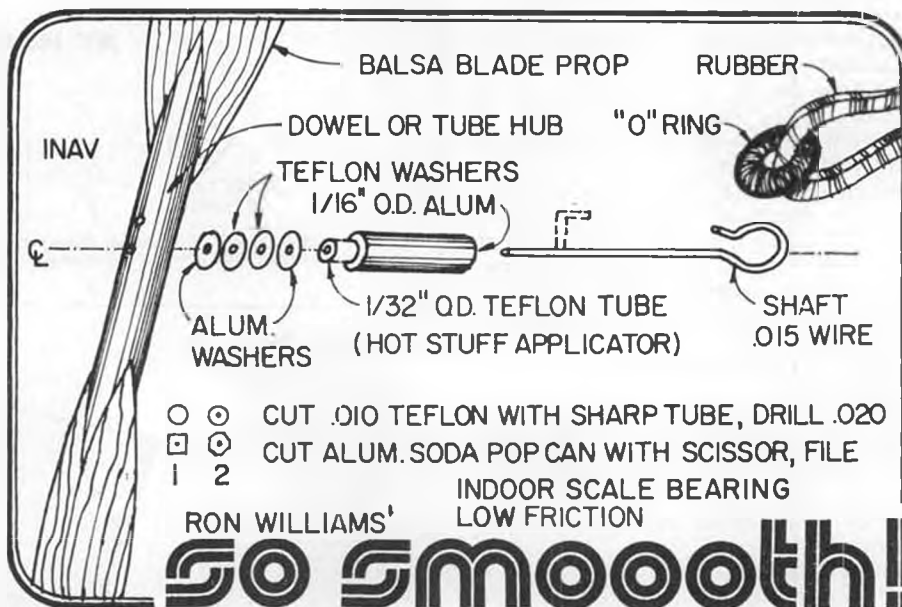

"It's the real thing," says Bill Warner of his litter-covered workbench in Santa Monica. Can you find the plane?



Mike Arak videos Charles Slater's Peanut Gossamer Condor as Doc Martin, Jurgen Kortzen back admire model.

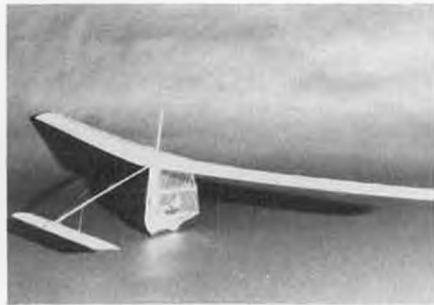

Charles Slater's Gossamer Condor up close.

clutter, with a sheet of Homosote (Celotex is okay) approximately 14 x 40 inches or larger lying flat upon it. Pins may be pushed into these materials easily for framework construction.

A good set of tools would include one or more sharp knives (Uber Skiver) with plenty of replacement blades, dozens to hundreds of pins, such as T-pins, a sandblock or two with a variety of sandpaper, screwdrivers of various sizes, pliers, a pin vise with a range of small drills, scissors, sharp-nose tweezers, at least one razor saw, some single-edge razor blades, a variety of small paint brushes, and a roll of waxed paper. Additional tools might include a few dozen Rocket City pin clamps, a small mitre box, a Dremel Moto-Tool or equivalent, and a scroll saw. These and a great many other items are quite useful, but not vital to construction.

A number of adhesives may be used in building indoor planes. On small work there is the good old acetate cement, but for the larger planes a good aliphatic resin glue (such as Sig Bond or Titebond) works very well, but requires from two hours to over-

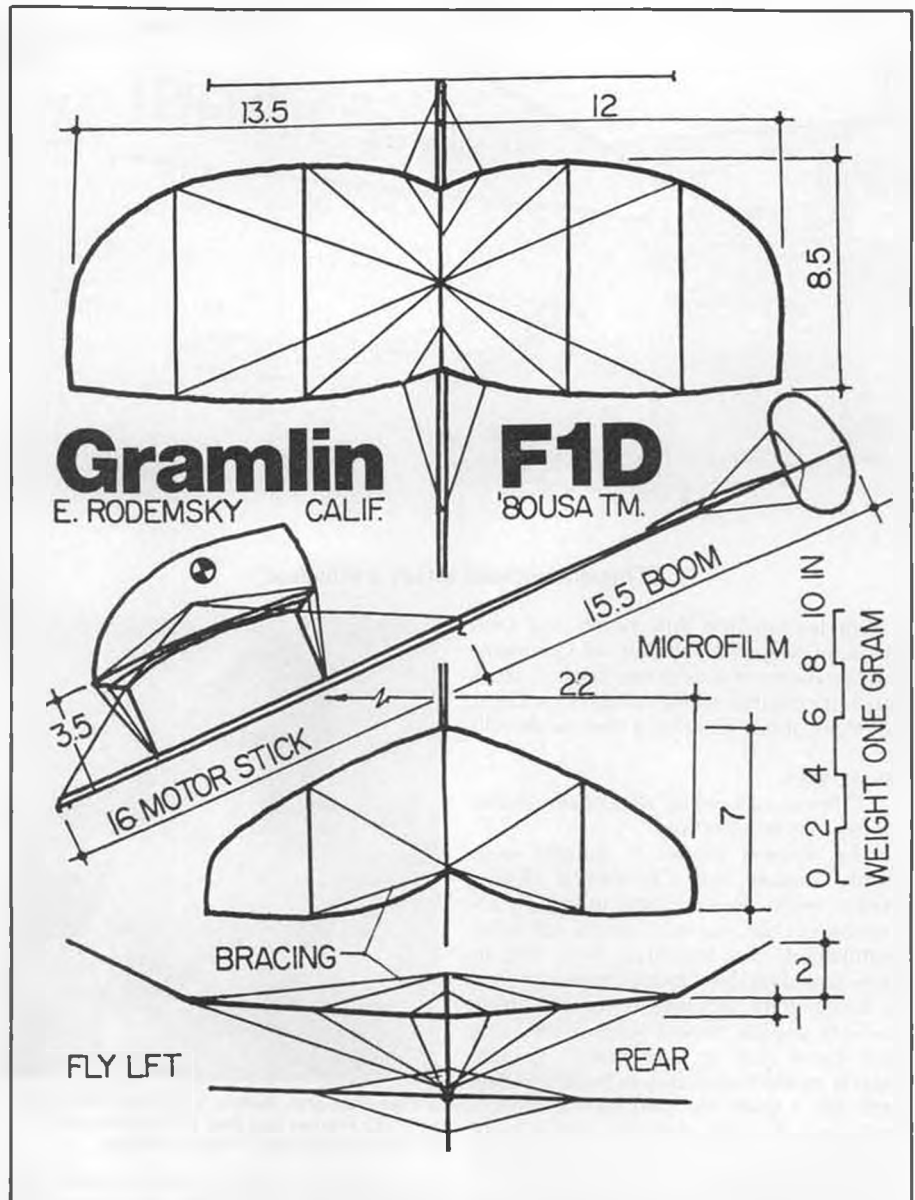

night to cure. Aliphatic is similar to white glue, but twice as strong. Modelers in a hurry often use one of the super glues (Zap, Hot Stuff, Jet, etc.). Five-minute epoxy should be used at points of heavy stress; nose, landing gear, wing root area, tail mounting, etc.

A good light source is a must, since any model work often involves fine detailing and other intricate work. A gooseneck or elbow lamp with a 100-watt bulb, or fluorescent tube, provides very good illumination.

*Continued on page 78*



MIAMA's Tony Becker uses stooze to wind his twin tail Manhattan Cabin model.



England's Nick Peplott won the Pistachio InterGnats with this beautiful 8-inch span Wittman Bonzo.



"Thought without action is valueless."

- Our lead-in line this month, via Don Mace, of Mace Model Aircraft Company, was the motto of a cash register firm years ago, but certainly applies to all of us. Don't just *think* about building a new model; do it!

#### MEMORIES

Bill Feeny, of Verona, Wisconsin, shares some of his recollections:

"The 10-cent models I bought were mostly Megow and Continental. Today, Megow seems to be pretty universally remembered but nobody seems to recall Continental, from Brooklyn, New York. In those days, I pictured model manufacturers as being giant factories employing hundreds of people. Now I suspect they (the kits) came out of somebody's garage. Megow models were okay to build and flew well. But I think the Continental models looked good in the plans, but didn't build very easily. There was always some glitch the plans forgot. I built their Spad, Hawk 75, Helldiver biplane, and Ryan ST. Also their Hornet, which had polyhedral wings and really flew well.

"Megow had a great catalog. Looking through it at hundreds of tiny halftone photographs was pure magic. I recall one Christmas, probably 1939 or '40, my father asked me what I wanted. I went through the Megow catalog and gave him a list of at least 50 kits!

"During the summer vacations, my father would remove the car from the garage and set up some card tables, and the kids on the block got together there, a-building. Kids today have substituted other interests, but I don't think they have more fun, or camaraderie.

"I built a Polish fighter and had a heck of a time with the wing. Others I recall are a Nieuport 17; a Corben Super Ace; a huge Megow \$1 Taylor Cub; a Cleveland Condor glider (seven-foot span), which sailed out of sight on its first flight; and a delicate P-26A with an unpainted square antenna mast and sagging black thread rigging. I took the P-26A to school for a display, and when I got home again I set it down on a chair while I took off my coat, and my dog sat on it.

"Eventually we 'graduated' to gas models.



Stefan Gasparin, builder of the world's smallest CO2 engines and Wee R/C systems with his Ansaldo biplane. Photo: Mueller.

But World War II was on and, as I recall, gas engines cost about \$30. My father had passed away, and we couldn't afford such a luxury. But only little kids flew rubber-

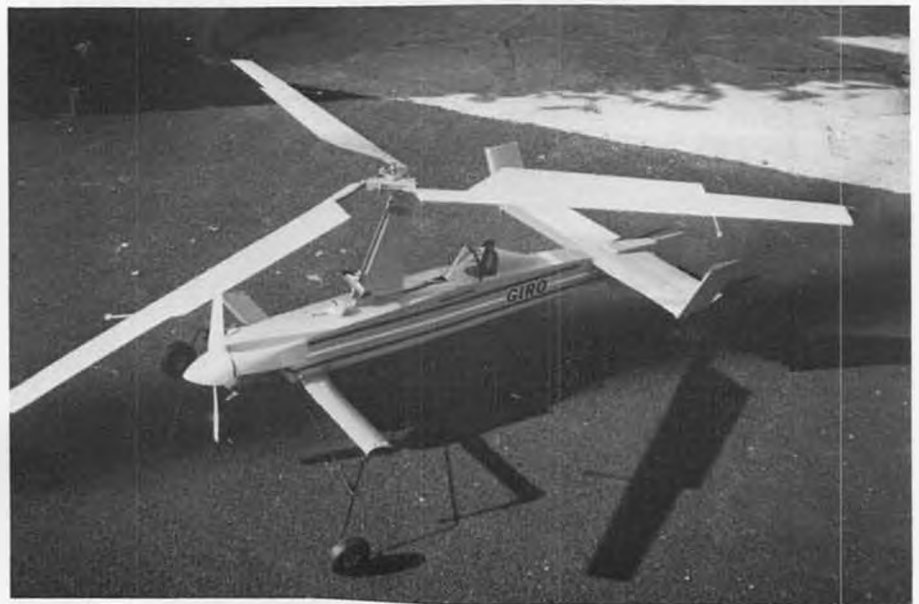

Another in a seemingly endless series of model autogiros by Georges Chaulet, of France, is this R/C version featuring auto pitch control and servo-actuated lateral rotor adjustment.

powered models, so I stopped. I was also sidetracked by high school, then college, then the Korean War and the U.S. Air Force, then marriage. I didn't start building again until becoming involved in plastic models. Looking back, the greatest satisfaction was in building those stick-and-tissue rubber-powered planes." Our thanks to Bill for sharing these nostalgic thoughts. Many of our readers may recall Feeny's fine series of illustrated articles in *Model Airplane News* during the 1960s called, "In Their Honor." Presently, Bill edits the *Plasticorner* newsletter.

#### MORE MEMORIES

Paul McIlrath, of Cedar Rapids, Iowa, favored us with several old model company advertisements. One, for the 1940s, described Jim Walker's winder for rubber-powered models. It was a simple twisted spiral of metal strip which revolved when a slotted handle was slid down its length, rather like some old toy helicopter-launching devices. The price of this winder? A mere ten cents!

Still cheaper were the Vivell all-balsa gliders, which sold for only a nickel and were available in your choice of World War I Ace Pilot markings. The example pictured bore the name, Capt. Eddie Rickenbacker. Wonder if it was the same Vivell who made model ignition engines.

#### DAVID DIELS DESIGNS

Remarkably, stick-and-tissue rubber-powered model kits continue to be introduced. One of our photos shows such a model, being kitted by Diels Engineering, Inc. The Curtiss Shrike, spanning 24 inches, is unusually complete, including printed plans, printed balsa sheet, strip and blocks, three colors of lightweight tissue, vacuum-formed canopies, full-color decal markings, a plastic propeller, plus a proof-of-scale three-view and photos of the full-size machine.

Diels also caters to Peanut Scale enthusiasts in a big way, offering a four-in-one kit containing the Brewster Buffalo, Vultee Vanguard, French Block MB-152, and Japanese Misubishi Raiden. This quartet of



Two Polish rubber models, a 24-inch span HL-2, and a Peanut Bozena, built and photographed by Alan Callaghan, of England.



Mark Fineman, of Hamden, Connecticut, built this fine Savoia Marchetti S.M. 92 from plans by Lubomir Koutny, of Czechoslovakia.

mini-flyers contains materials as complete as furnished in their larger kits, and manufacturer Dave Diels explains that the quartet of Peanuts did indeed take four times as long to produce as one kit would have, even though they are all packed in a single box!

Dave also markets the canopies and decals separately. Why not drop him a line requesting the complete price list? Diels Engineering, Inc., Box 101, Woodville, Ohio 43469.

#### DOCUMENTATION DRAWINGS

While you have your stamped, pre-addressed envelopes handy, you may also care to send to Charles L. Neely's for his list of aircraft scale drawings. Draftsman/Illustrator Neely offers such subjects as Neta Snook's Curtiss "Canuck," in which Amelia Earhart learned to fly; the 1929 Taylor Chummy; the 1929 Mono Monosport, Lindbergh's custom Monocoupe; and the North American P-51B/C and D/K Mustangs. Neely, Box 363, Visalia, California 93278.

#### RIGGING MATERIAL

We recently received samples of small-diameter stainless steel wire, ideal for detailing scale models. Much smaller in diameter than commonly found, each kit contains four pieces of .004 diameter and six pieces of .008 diameter wire about ten inches long. Also included are instructions for use, as well as a conversion chart listing the size equivalents for various scales.



Wanna buy a slightly used Gee Bee? Dick Allen, of Canada, tells the tail this month.

Price is \$3.25, includes 25 cents postage, from: Clay Boyd, 994 N. Murdock, Pleasant Grove, Utah 84062.

#### EXOTIC FRENCH OUTERWEAR?

We recently received a rather mysterious-looking package with the above label. Inside was a high-quality T-shirt featuring a tiny Henri Mignet Flying Flea (Pou-du-Ciel) on the front, and a squadron of them on the back. The charming garment was sent by Randy Wrisley, well-known builder of Pous in all sizes. Although Randy didn't mention any prices for his Pou-shirts, we'd guess you could find more information by asking him: Randy Wrisley, 206 South Lyon, #6, Santa Ana, California 92701.

When writing to any of these people, how about mentioning *Model Builder* magazine? Thank you!

#### CONTINENTAL CONTESTS

Fritz Mueller, renowned for his creative solutions to Wee R/C, CO., compressed-air engines, etc., recently attended a contest in Hungary, in the company of his charming wife Erzsi. Although he was accustomed to some difficult weather conditions in his home state of Georgia, he was unprepared for this: "... they have huge plains with legendary tall grass, hardly a cloud in the sky, cool dry air, (but) almost steady wind! Nobody cared to mention that if you grab a model, this wind will fold a wing in no time.

On the morning of the contest, held south of Budapest, Fritz assembled the models he had brought along, and posed for the mass photo:

"The 'mass' consisted of one Austrian, about fifteen Czechoslovakians, and some twenty Hungarians. I had no idea how hectic such a contest could be; everybody busy in preparing, rigging, testing, throwing, breaking, repairing, breaking again, adjusting, throwing again, running, happy faces, long faces. All of this could have been fun for me to see, if it was not for the fact that I had my models, was a registered participant, and was thus morally obligated to fly!" To make a long story short, Fritz managed to place about thirteenth, and the unique features of his models were ex-

*Continued on page 93*



Florida's Jake Larson's rubber-powered Curtiss Shrike, built from a Diels Engineering kit. Details in column.



A Peck-Polymers kit D.H. Gipsy Moth in Spanish markings by Dr. Harvey Pastel, of Manchester, Connecticut.

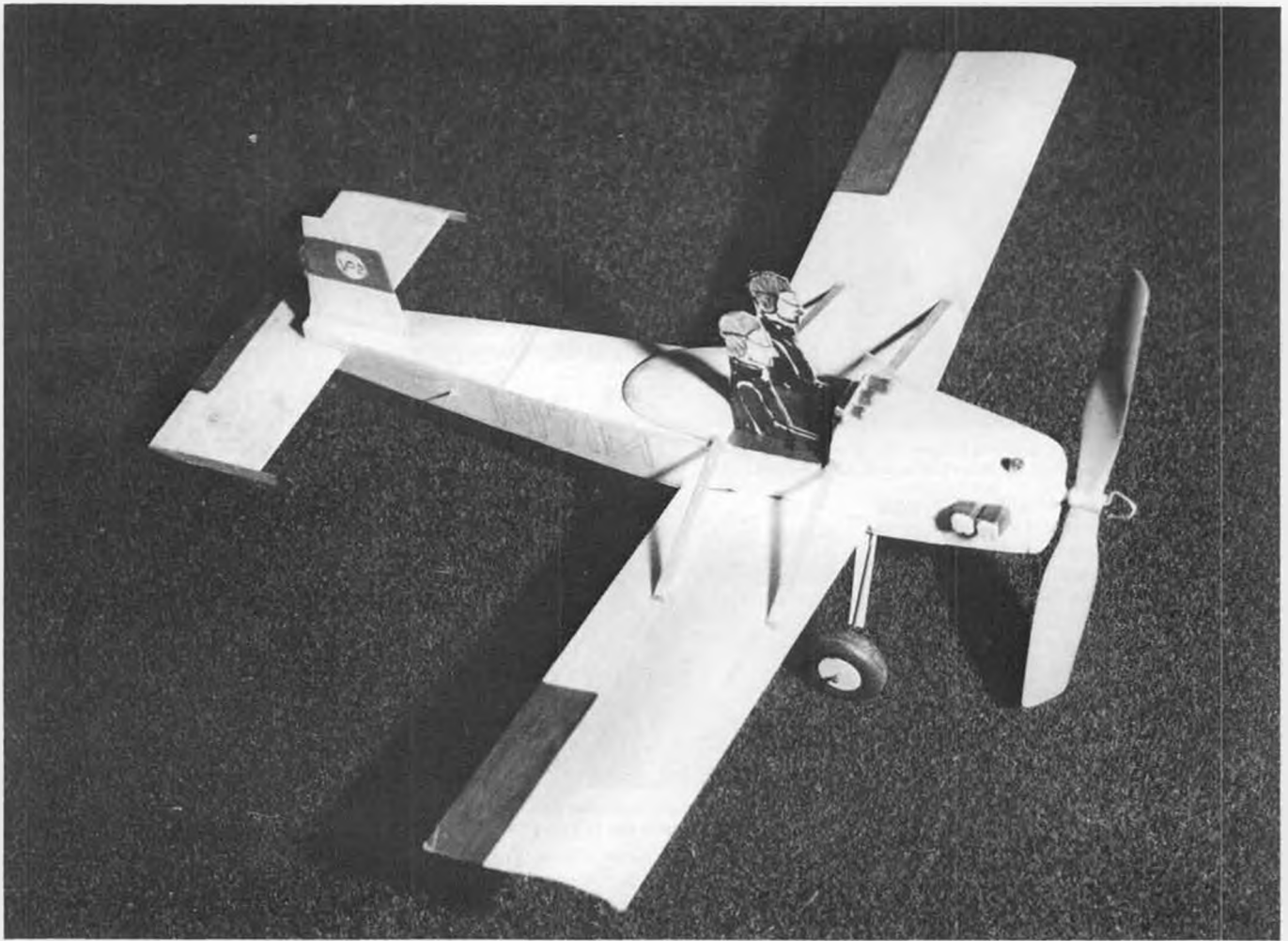

# EVANS VP-2

By WALT MOONEY. . . We go way back to 1973 for this gem of a Peanut based on a popular Volkswagen-powered homebuilt. It's made of sheet balsa, which makes for quick and easy building.

- This is an all-sheet Peanut Scale model of W.S. Evans's two-place version of the Volkplane. Basically, the real airplane is a little wider with a little more wing area so that it can carry two people. The design is a good one for a person wanting to build his first airplane because of its simplicity, and that very simplicity makes it a good design for a model to be built in a hurry and within the capability of near beginners.

This particular design was evolved so that the author's whole family could each build themselves a model for a Las Vegas New Year's Peanut Scale contest. Five models were built in one evening; the details and decorations were put on in an hour or so the following day during the 1972 Christmas vacation. Dad added pilots, instruments and dummy cylinders to his. One son added a fancy felt pen color scheme. Mom added a little color and a woman pilot, and daughter and the other son left theirs pretty plain.

In Las Vegas, they all flew, but the author's wife got the longest flight out of hers by 2/5 of a second, leaving him second best, as usual.

Because the model is so simple and because construction articles have been done so often before and because the editor says the author is guilty of glossing over the techniques of flying these things (*And he admits it, too!—wcn*), the construction will not be mentioned. It is assumed that you have a

finished model and are about to start flying it.

After many years of observing my models and other people's models, we have concluded that the reason for poor flying characteristics narrows down to only a few specific problems.



Simplicity of design make this a good project for sheet balsa construction.

First and most common is the center of gravity being too far aft. The further forward the airplane's balance point (CG), the more stable the model will be. This must not be carried to extremes or the model will have the absolute stability of a bomb. Nevertheless, if your model flies erratically in any fashion, check to see that it balances at the point shown on the plans, and even if it does, it may be worth your while to ballast the model to move the balance point an eighth of an inch or so further forward.

The second most common problem is warps, or surprisingly the lack of them. Significant nonsymmetrical warps are obvious problems, and should be eliminated. On most models there is one wing warp that is, if not absolutely essential, at least almost always beneficial. This warp is referred to as "washout," and is a symmetrical warp in which the trailing edge of each wing is warped up as it proceeds towards the wing tip, so that the tip of the wing flies through the air at a lower angle of attack than the wing root. A model that stalls and then drops a wing can be a disaster; one that wobbles from side to side is a disaster waiting for a place to happen, and washout will usually cure the problem. (Please take note of the VP-2 wingtips in the photos.)

The above are the two most important items; all the other problems can be solved with propeller thrust line changes or elevator and rudder setting changes, except one. This last one is rare, but occasionally a modeler will put on a propeller that is too big or has too high a pitch, and the model will be unflyable for any length of time. Generally, it is easier to adjust a model to fly consistently with a small propeller than

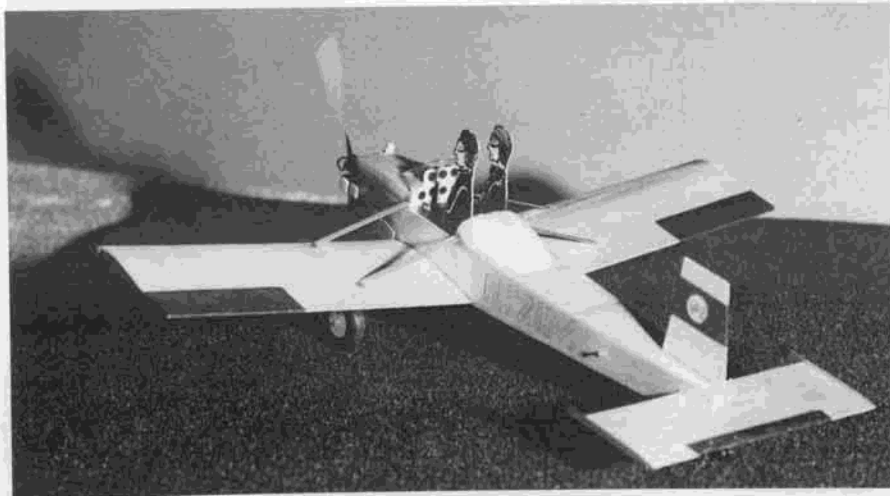

Model flies well even with two profile pilots in the cockpit. Text describes trimming and proper rubber use for max flights indoors or out.

with a larger one. Durations are lower with a smaller propeller, however; if you are interested in long flight time, you will tend towards the larger diameter, slower turning, higher efficiency propellers.

Once the model is balanced right and has no wrong warps, and enough of the right ones, it should be glided power off; that is, with the propeller freewheeling or with very few (not more than 50) winds if you don't have a freewheeler. The glide path is adjusted with the horizontal tail. If the model dives, bend the trailing edge of the horizontal tail up. If the model stalls, the trailing edge of the tail should be bent down. The amount of displacement of the trailing edge of the tail to provide enough adjustment is fairly small, so proceed care-

fully and take your time at this stage.

The model should glide in a relatively straight line. A sharp turn can be corrected by moving the trailing edge of the rudder in the direction away from the turn. However, if your rudder looks straight at this point, a turn is almost always because of a warp in the wing. Sometimes, if the propeller is large and does not freewheel, its effect is to make the model roll and turn to the right, hence the reason for the few winds during the glide tests.

Once the model is gliding satisfactorily, it's time to start the powered test flying. Here, the procedure is to add power (winds) a little at a time, flight by flight, so that the

Continued on page 84

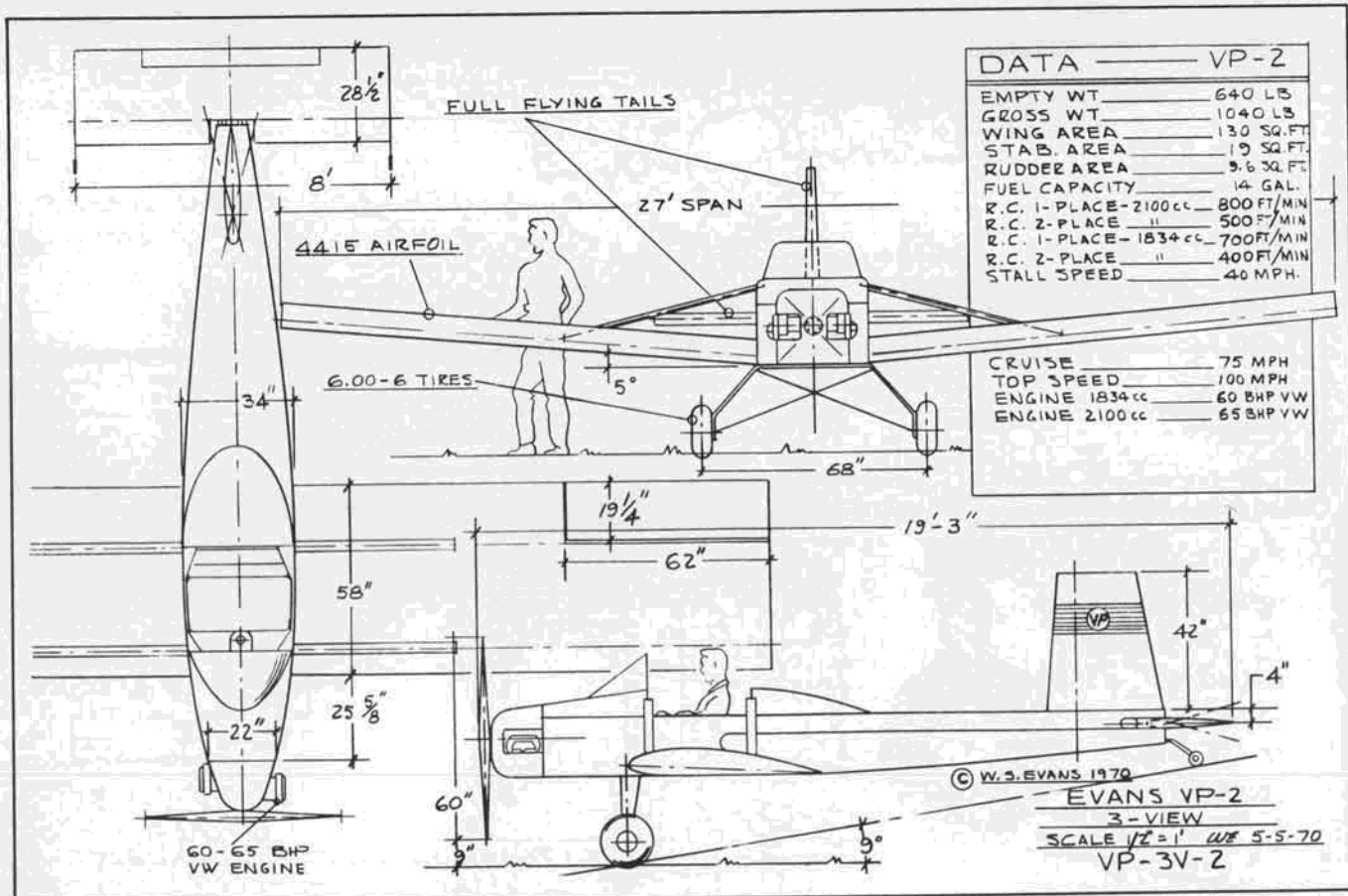

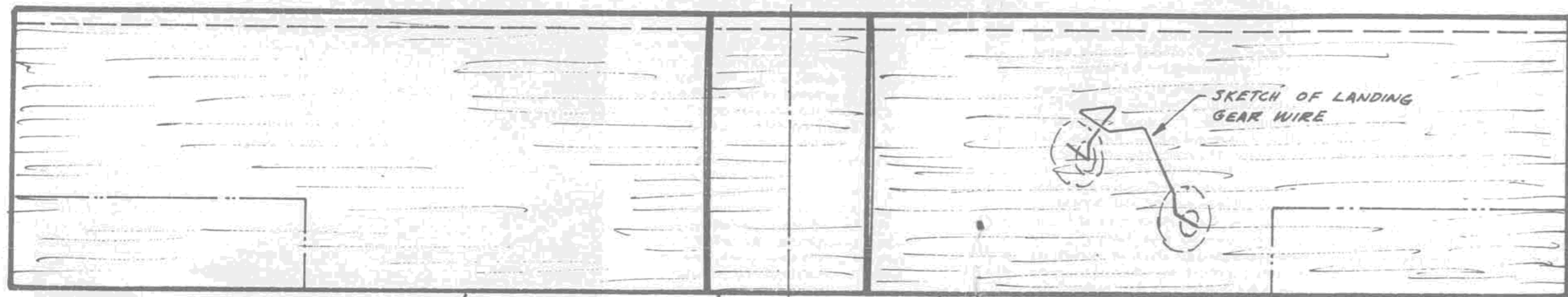

1/16 x 1/8 LEADING EDGE REINFORCEMENT

WING AIRFOIL CURVATURE (AIRFOIL) SHAPE IS OBTAINED BY GIVING UNDER-SIDE IN THIS AREA ONE COAT OF THIN DOPE.

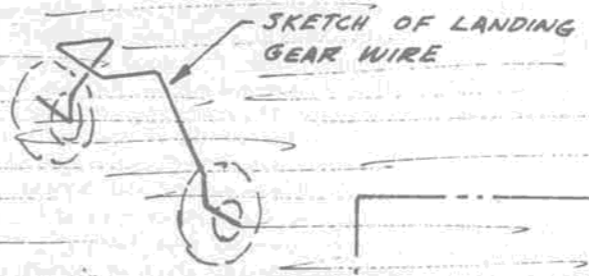

SKETCH OF LANDING GEAR WIRE

LEFT WING  
 PLASTIC PROPELLER WITH A PECK POLYMERS THRUST BUTTON. HOOK IS BENT FROM 1/32 ND. DIA. WIRE - NOTE WINDING HOOK ON FORWARD END IN SIDE VIEW AND HOOK SHAPE ON RUBBER END IN TOP VIEW. CYLINDERHEADS ARE SCRAP BALS

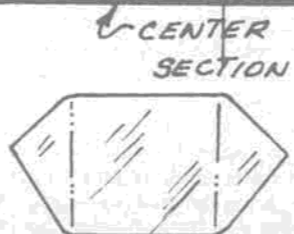

CENTER SECTION  
 WINDSHIELD PATTERN HOLE IN BOTTOM SKIN SO YOU CAN SEE RUBBER WHEN INSTALLING IT

RIGHT WING  
 FOR BEST FLIGHTS USE A MOTOR OF 1/8TH FLAT RUBBER IN A LOOP AT LEAST 14 INCHES LONG

STRUTS - MAKE 4

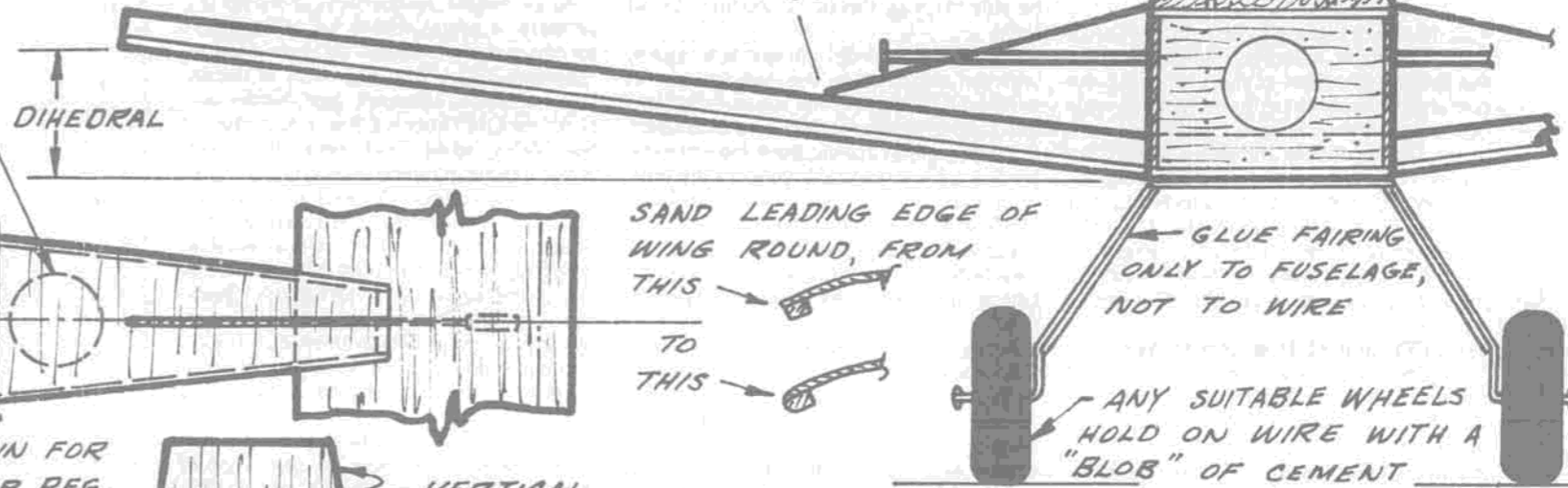

GLUE FAIRING ONLY TO FUSELAGE, NOT TO WIRE

ANY SUITABLE WHEELS HOLD ON WIRE WITH A "BLOB" OF CEMENT

SAND LEADING EDGE OF WING ROUND, FROM THIS TO THIS

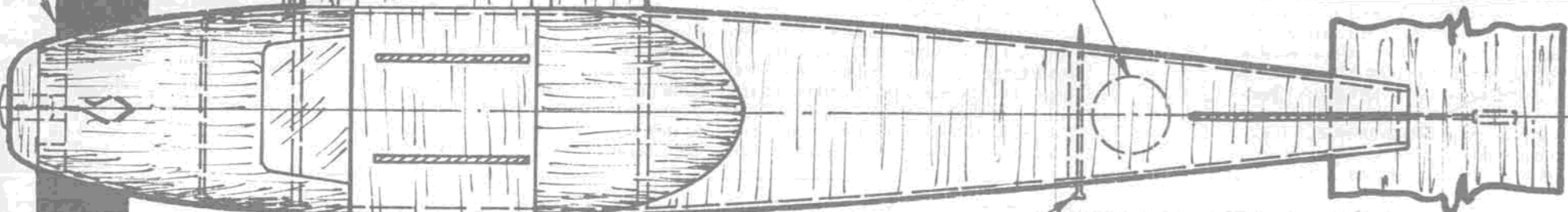

TOP VIEW

PIN FOR REAR MOTOR PEG.

VERTICAL TAIL

BLOCK BALS FRONT COWL

2 PILOTS ARE 1/32N SHEET BLOCK BALS TURTLE DECK

SIDE VIEW

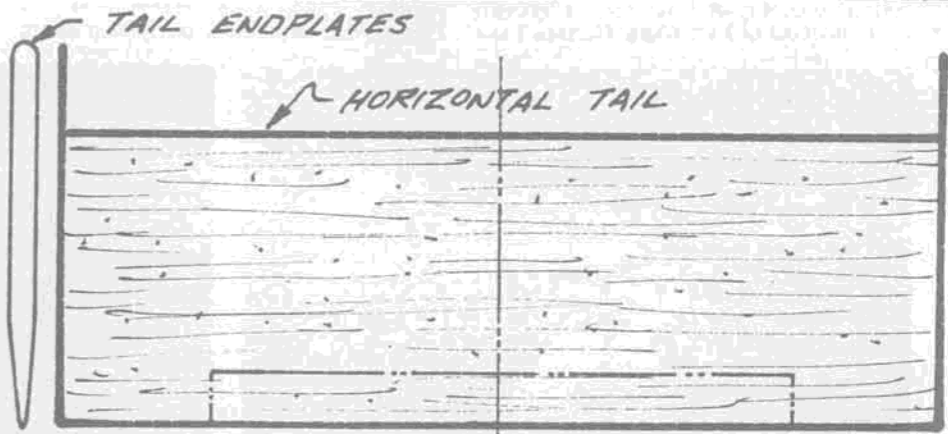

TAIL ENDPLATES

HORIZONTAL TAIL

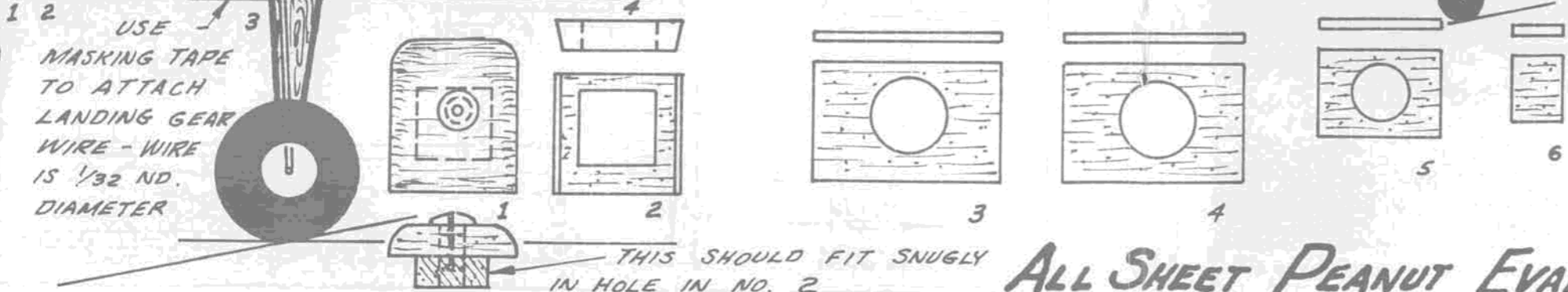

USE MASKING TAPE TO ATTACH LANDING GEAR WIRE - WIRE IS 1/32 ND. DIAMETER

THIS SHOULD FIT SNUGLY IN HOLE IN NO. 2

NOTE: ALL PARTS ARE SHEET BALS UNLESS OTHERWISE NOTED. 1 & 2 ARE MADE FROM 3/16 TH THICK STOCK, 3, 4, 5, & 6 ARE 1/16TH THICK, ALL THE REST OF THE SHEET PARTS ARE 1/32ND SHEET. NOTE GRAIN DIRECTION.

ALL SHEET PEANUT EVANS "VP-2" Matt Mooney 12-27-72





# Free Flight

By BOB STALICK

across this A-2. Its designer is a well-known American FAI Flier who had put this ship together to participate in the 1969 FAI Team Selection program. One more hint, the ship is named after a rather famous cartoon character.

Now, if you know the name of the ship, drop a card or letter in the mail to Bill Northrop, *clo Model Builder* magazine. First in line with the correct answer wins a free, one-year subscription. Longtime NFFS members who saved their Digests should be able to locate this one in no time. Good luck!

It's *Mystery Model* answer time again, and you might know, we have to start off with a tie, which means we give out two free subscriptions for two correct answers that, with handicapping, were the first to be posted. Like we've said before, it's the postmark that counts. . . not when it gets here. We have to have *some* kind of fairness, and usually. . . usually, the P.O. will postmark your letter the same day you drop it in the box. . . if you get it there before the pickup time.

Anyway, Charles Schaaf, of Forks, Washington, and Phil Oestricher (again?!) of Ft. Worth, Texas, correctly and quickly identified Sal Taibi's "Zenith" as the May Mystery Model. Surprisingly, one well-known free fliker, whose name we won't mention, called it the "Powerhouse!" Of course, that airplane is pretty well identi-

fied with Sal, even though another famous modeler had a model of the same name. . . you remember Dick Korda.

"I've been meaning to send you Mystery Model names for a long time, but I just keep forgetting." Well, it's a good thing you finally got "a round tuit," as they say, Carl Stokes, of Seattle, Washington, because you were the firstest with the mostest by naming Al Casano's "Nightmare" as the June Mystery Model! Now aintcha glad you wrote?

It seems we have a FIRST. As far as we can remember, there has never been a Mystery Model published for which we received no answers. . . correct or otherwise. . . until now. July's model was the "Atakee," designed by Rudolf Das of the Netherlands, and published in a 1954 issue of *Aeromodeler*. Not shown in our drawing were the tip fins below the stab, having the same shape but less than half the size of the center upright fin. They were mounted parallel to the centerline.

As for August, no problem about getting answers. It seems that a lot of modelers recognized the "Batiri," by Jose Manuel "Manny" Tellez, who now lives in nearby Laguna Beach. However, free fliker and part time Old Timer nut Bruce Augustus, of Sun Valley, Idaho, had the earliest postmark, handicap or no.

And finally (our October issue is just about to be released as this is written), the September Mystery Model winner is Gene Martha, of North Attleboro, Massachusetts. Yes, it certainly was Chet Lanzo's "Sway-back," a name it came by honestly enough as the fuselage profile resembled an undercambered airfoil. . . even more undercambered than the airfoil for the wing of this design.

This month we're happy to announce two more overseas winners in the Mystery Model competition. One is not exactly across water, but is in far away Mexico City.

• Is there free flight activity in Hong Kong? Well, I doubt it; however, I will be leaving the friendly confines of the U.S. of A. just one after this month's column hits the mailbox. And while I am there, I will take a look at the hobby outlets and other interesting things; cameras, camera timers, silk factories, etc. If anything looks interesting, I'm sure that you will be reading about it in the next issue of *Model Builder Free Flight*. In the mean time, I hope you find something interesting as you read the November column.

## MYSTERY MODEL FOR NOVEMBER

Dihedral is making a comeback. Some of the recent and state-of-the-art FIC designs have featured V dihedral with little tiplets to assist with stability. I have had a soft spot in my head for a number of years for V dihedral. Recently, as I was leafing through my collection of *Free Flight Digests*, I ran



Bruce Augustus, reportedly one of only two active free fliers in Idaho, with his Maverick 1/2A model, seen at Madera, California.



Julia Augustus (the other active free fliker in Idaho) with her dad's Starduster 900. Photos: Augustus.

Roberto Guzman was quite prompt in identifying Jose Tellez's "Batiri," as he was with Jose in Mexico City when the model was first designed and built, and the two young modelers worked together on the first test flights. Roberto built a model of his own, using the Batiri wing and tail, but with a fuselage using vertical and horizontal sheets that formed a "diamond" outline. It was named the "Trou-Trou," and went OOS just after winning a contest in Mexico.

The other overseas winner is Franz Czerny, of Vienna, Austria, who was not confused by the later similar model published in *Aeromodeler*, but correctly identified the "Martian Space Ship" by Roy Clough in the April issue. Franz went on to mention many other unusual designs by Roy Clough in early copies of *Popular Science* as well as other magazines. Roy certainly was prolific and also what is nowadays called "free-spirited" when it came to designing very original models. We are still hoping to hear from someone as

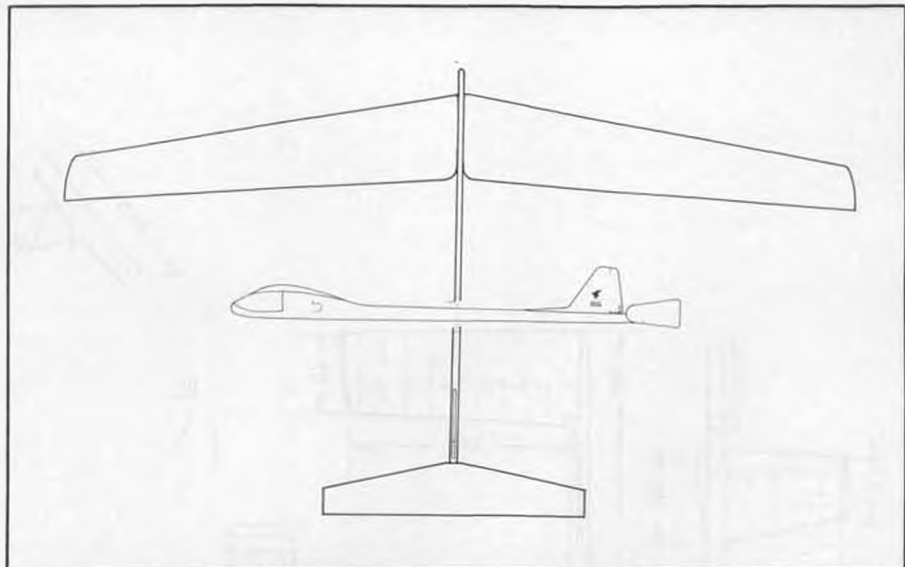

November Mystery Model



Terry Thorkildsen VTO's his 1/4A Top Banana in Nostalgia. Model is powered by a Nostalgia-legal Cox TD .020.



Bob Hatscheck, editor of the *Flyoff*, the newest FF newsletter, here appears to be thinking of something to write about.



Jack Nix and his F1C ship seen at the Galeville, New York semifinals.



Dave Rounsaville launches his F1C at the Galeville semifinals. Love that form! Photos: Jim Bocckinfuso.

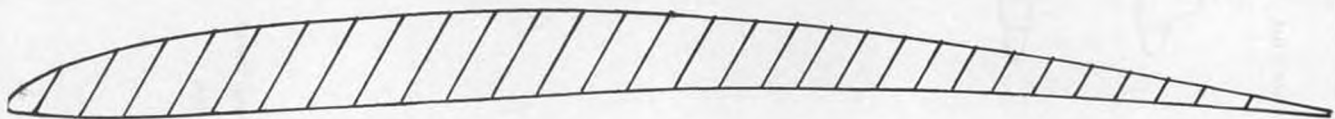

Chord	0	2.5	5	10	15	20	25	30	40	50	60	70	80	90	100
Upper	1.08	3.28	4.25	5.54	6.45	7.15	7.58	7.85	8.01	7.69	6.99	5.81	4.30	2.53	0.43
Lower	1.08	0.18	0.11	0.18	0.45	0.70	0.97	1.18	1.72	2.10	2.28	2.10	1.61	0.91	0.00

Rossi 15, 3 deg. downthrust

Wing root at 2 deg.

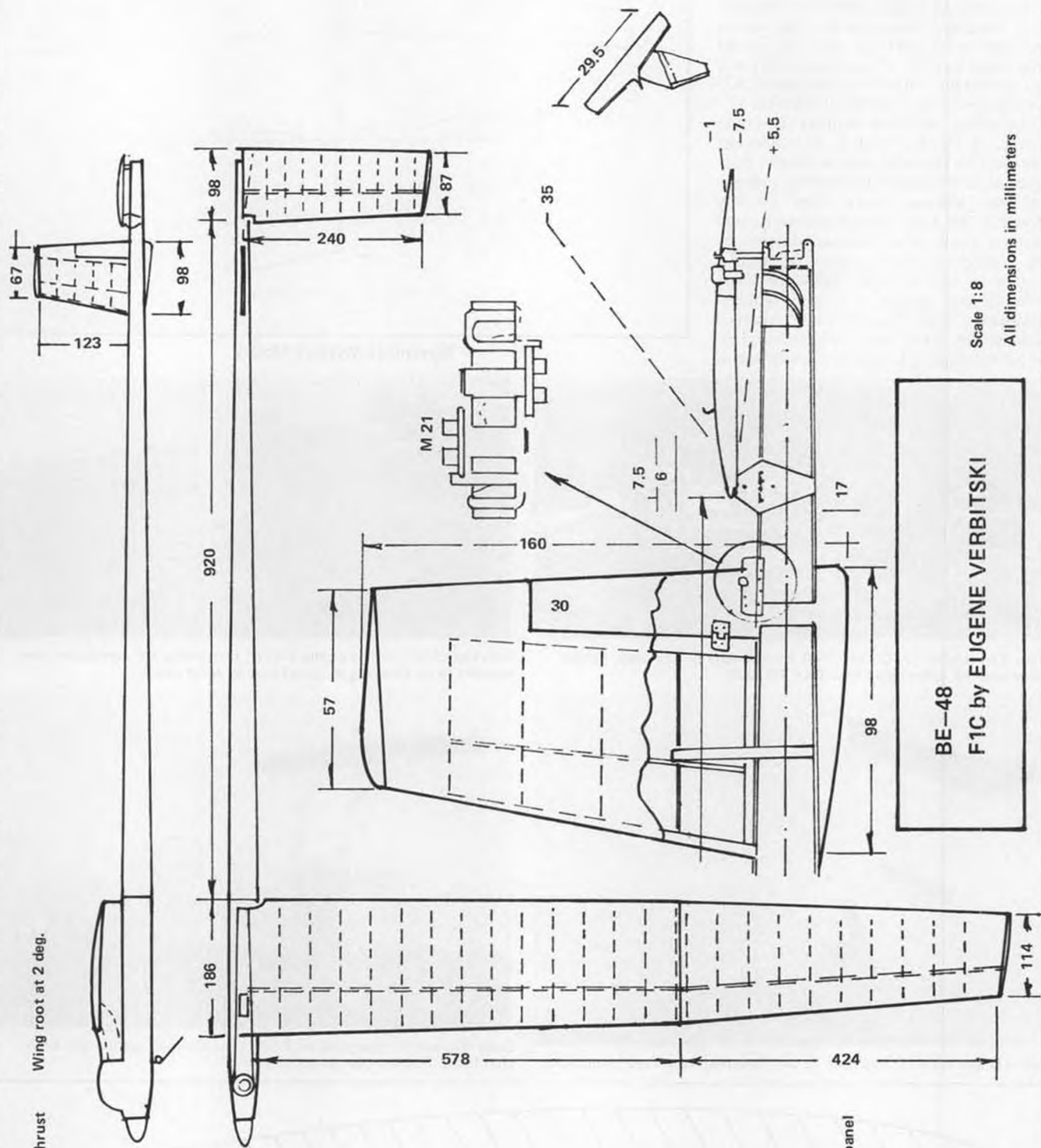

DIHEDRAL  
30 inner panel  
170 total at tip

0.5 deg. washout over inner panel  
+ another 0.5 deg. over tips

BE-48  
F1C by EUGENE VERBITSKI

Scale 1:8  
All dimensions in millimeters



Bill Darkow, editor of *Classic Flyer*, launches his *Oily Boid*, an enlargement of Frank Ehling's *Delta Dart*. Bill's flies well with a Pee-Wee .020 engine.

to the whereabouts of Roy Clough. Can anyone help?

#### NOVEMBER THREE-VIEW—Verbitski's BE-48 F1C

This is the current design of World Power Champion Eugene Verbitski of the USSR. The BE-48 means that this ship is the 48th in his series of power models.

As you peruse the plans, please note that some detail has been included for the autorudder and the autostab with bunt system. It may be that the details are not clear enough to figure them out. If such is the case for you, let me suggest that you order a set of full-size plans, which are available from Sal Fruciano, 6146 E. Cactus Wren Rd., Scottsdale, Arizona 85253, for a \$5 bill.

I call your attention to the coordinates included with the three-view. These coordinates are for the propeller—handmade out of carbon fiber. No stab airfoil or coordinates were included with the three-view that I received, but the wing airfoil is presented as this month's Darned Good Airfoil. Center of Gravity is also unstated, but it is safe to estimate that it is located somewhere near the 60-percent mark.

Of note regarding the wing is that it is covered with 1.2mm balsa top and bottom and then .03mm dural is adhered over the balsa sheeting for a really bulletproof, slippery surface. Nice ship from a world-class competitor.

#### DARNED GOOD AIRFOIL—Verbitski's BE-48

This is the airfoil used on the model that is this month's three-view. What is noteworthy about this section is that it features undercamber fairly far back in the airfoil. Other features are common on contemporary F1C models; e.g., balsa sheet covered with aluminum skin, two-piece high aspect ratio wing section that plugs into the fuselage pylon.

As mentioned earlier, the stabilizer airfoil is not shown in the three-views, but if current practice is followed, it will be a very thin (five percent or so) flat-bottomed section with a raised Phillips entry or a thin semi-symmetrical section. One item of note on the stabilizer is that it is only 13 percent of the wing area. Of course, the tail moment of the ship is just at 36 inches, so a big stabilizer is not only unnecessary, but undesirable.

So, if you are not interested in building Verbitski's model but you are thinking about a fast-climbing FAI ship of your own, you should consider this airfoil. After all, it

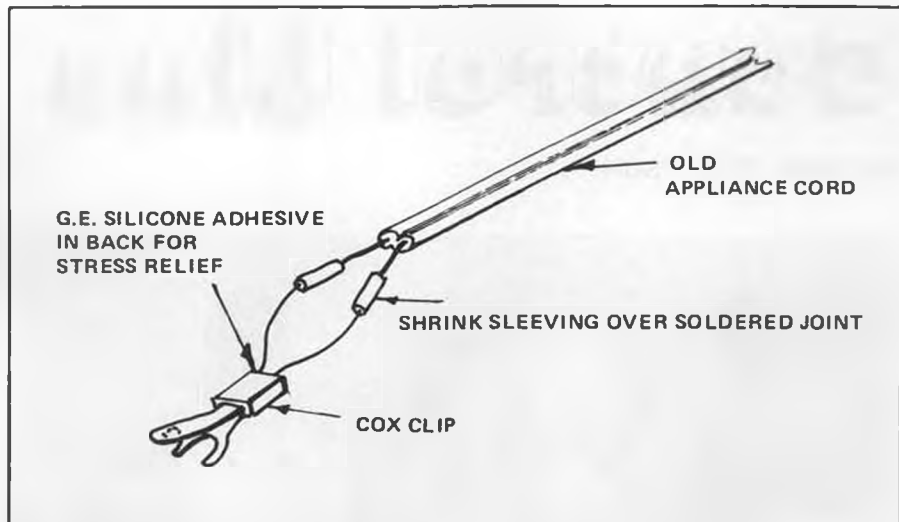

Sketch 1. Cox glow clip modification.

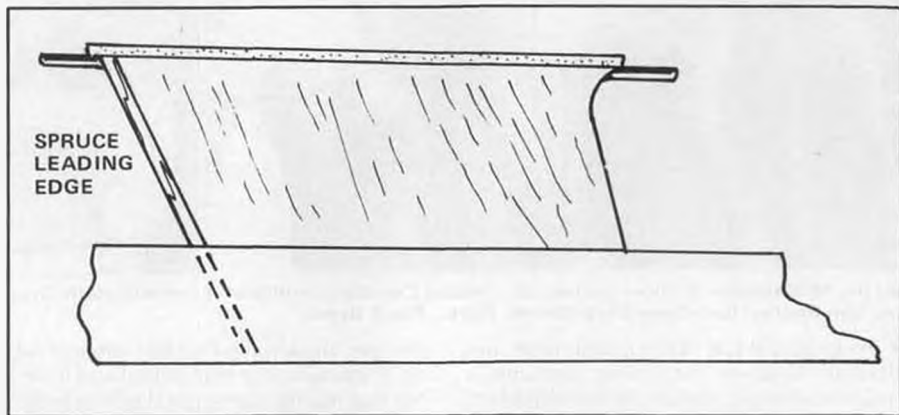

Sketch 2. Pylon reinforcement (see text)

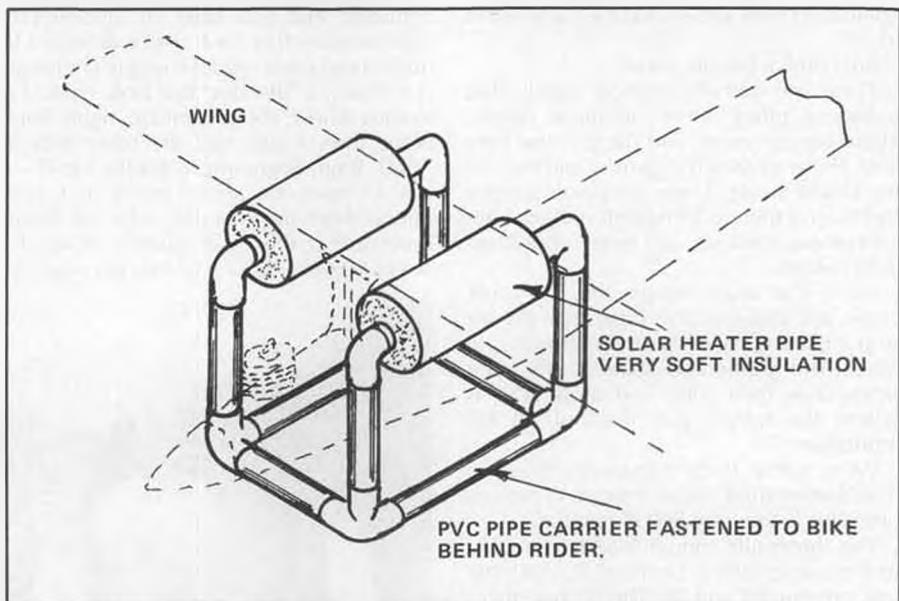

Sketch 3. Hank Sperzel's motorcycle-mounted model carrier. See text.

is the one that was used by the current F1C Champ.

#### MORE FROM SAL TAIBI

During the past several months, the *Minneapolis Modeler*, newsletter of the Minneapolis Model Aero Club, has been publishing excerpts of a conversation between club member Jorge Triana and Sal Taibi. This conversation was taped during the

1987 Nats at the University dorm where both were staying. This excerpt provides an insight into Sal's winning ways.

JT: How much nitro (do you use)?

ST: I'm running 65-percent nitro. You can use any nitro you want; 10, 20 percent, whatever. It gets up so high that a 650-

*Continued on page 93*

# Control Line

BY JOHN THOMPSON



At the 1988 Bladder Grabber contest, the dreaded Canadian contingent. From left: Kelly Crozier, Lyn Murray, Greg Davis Greg Wornell. Photo: Frank Baden.

• As long as it has that unusual name, the Bladder Grabber may never become a household word, outside the households of control line combat fliers. You have to know something about model aviation, about combat, to even know what the name refers to.

But combat people know.

There are certain sporting events that transcend other, almost identical events. There are car races, and there is the Indy 500. There are baseball games, and there is the World Series. There are tennis tournaments, and there is Wimbledon. And there are combat contests, and there is the Bladder Grabber.

Here, the music stops, the townfolk come out and line the street, the glasses stop tinkling, and even the horses are quiet. The gunfighters stand facing each other, draw their guns, and shoot. This is where the fastest gun lives up to his reputation.

We've got so many metaphors mixed in here that we might as well return to the first one. This is the Indy 500 of combat.

The thirteenth annual Bladder Grabber took place in 1988 in Snohomish, Washington, on June 25 and 26. The license plates in the parking lot were from Texas, Michigan, Canada, Kansas, Arizona, Utah, all the other Western states, etc. The flying was, as always, from out of this world.

(Somebody's crying for mercy. You're not "combat people"? What does "Bladder Grabber" stand for? Okay. Look at the wing of the AMA fast combat airplane. There's a little hole with a fuel line coming out of it and heading toward the engine. Pull on the tubing and a bigger piece of tubing

emerges, thick-walled rubber surgical tubing. If you take a syringe of fuel and force it into that tubing, the surgical tubing begins to blow up like a balloon. Route that tubing to the engine, perhaps through a pressure regulator, and you have an ultra-simple, high-pressure fuel feed system designed to make a two-cycle model airplane engine go fast. That is a "bladder" fuel tank. Now, you already know about combat, right? Each plane tows a streamer, the other tries to "grab" it off. Beginning to get the idea?)

AMA combat is almost poetic in its simplicity. Start the engines, take off, begin combat, cut the other plane's string, the match is over, you won or lost; get ready for

the next one. Everybody can follow it; the judges, spectators, pilots, pit crews. There are no gray areas and no need for a lawyer in the pit. (Yes, *theoretically*, some guys can find an argument anywhere, some things just happen too fast for any human being to judge it without being second-guessed (or being wrong; ask any umpire or baseball player).

The Bladder Grabber raises AMA combat to above-normal levels.

For one thing, it's full triple-elimination; more chances for every entrant to catch up, make up for a bad flight or two, etc. This tends to make the cream rise to the top by reducing the "luck" factor, but at the same time it encourages the flier who gets a bad start to hang in there and keep trying. Full triple-elimination means that everyone flies until they have three losses.

Secondly, the Bladder Grabber has simply the most coveted array of prizes available anywhere. More than \$10,000 worth of high-tech, high-quality Carver Corp. stereo equipment is up for "grabs." But, I suspect that most past winners would point to the simple pewter mug engraved with the words, "Bladder Grabber, 19??—First" as their most revered combat prize.

The driving forces behind this contest are several.

First there is the sponsor, Bob Carver, owner of the Carver Corp. and designer of the Carver stereos (amplifiers, pre-amps, tuners, CD players, speakers, car stereos). Carver each year donates the prizes and buys every competitor and his pit crew and all the officials breakfast as well (I've never counted, but I'd guess the breakfast normally draws about 75 people). Bob happens to be a combat flier who years ago decided to sponsor the best contest around. He's always present to be one of the toughest competitors as well, and finished seventh in 1988.

Then there are the people who actually make the contest happen. Heather Hawley, Carver Corp.'s chief engineer, who is the administrative genius and the key paperwork handler. Howard Rush and Norm McFadden, two of the top combat fliers who live in



The top 5 at the Grabber: Phil Granderson, 4th; Spencer Sheldrew, 2nd; Steve Kott, 1st; Bob Carver, sponsor; Mike Petri, 3rd; and Greg Wornell, 5th. Photo: Cameron.



Ed Brzy's planes are always unique. Photo: Thompson.



The Stealer by Larry Drishill, from Texas.

the Seattle area, handle the details of securing publicity and officials.

The contest director and officials vary from year to year, but each year they are of the highest quality, integrity, energy, and efficiency. In 1988 Norm McFadden was the contest director, two-time winner Chuck Rudner was the event director, and a solid crew of full-time officials handled the cut counting, time, pull-testing, line measuring streamer administration, etc. Two judges were attentive to each airplane to assure accurate scoring.

The 50 entries gathered at the airport restaurant at Harvey Field in Snohomish, Washington, at 7:00 a.m. on Saturday for the breakfast, registration, and precontest meeting. Flying started at 9:00 a.m. and continued with two minutes between matches until the late rounds on Sunday.

After something approaching 200 matches, the winners emerged.

Appropriately, it was U.S. FAI Combat Team member Steve Kott, of Wayne, Michigan (a previous winner), in first place; relative newcomer Spencer Sheldrew, of the Seattle area, second; Mike Petri, of Redwood City, California (another former winner), third; Phil Granderson, of Portland, Oregon (still another former winner and former U.S. national combat champ), fourth; Greg Wornell, of Vancouver, B.C., fifth; and famous combat star Rich Von Lopez, of Los Angeles, sixth.

Among the tidbits observed in the thirteenth annual contest:

\*An external bellcrank with leadout guides on both wingtips helped one competitor get up again after losing a wing. Leadouts were switched to the opposite wing and flying resumed.

\*The "Dreaded Canadian Contingent," from British Columbia, made its best showing ever, placing Wornell in the top five and acquitting itself well in many matches. Characterized by their instant starts (which were some of the evidence of great improvement over the past several years) and their irrepressible good humor, the six team members worked up their intensity by chanting the theme from "Mad Max Beyond Thunderdome" (Two men enter, one man leaves!). The contingent also awarded its annual "BC Bellcrank Award" to Ed Brzys, of Michigan, for his destruction of five airplanes.



Steve Hill's model, the most innovative design at the '88 Bladder Grabber.



Judges for the '88 Grabber contest. In center, Event Director Chuck Rudner. Foreground, Jim Cameron, and Dave McFadden.

\*On the other end of the carnage index, Marvin Denny, of Wichita, Kansas, was observed to use the same plane in five matches, showing the value of building 'em tough and keeping them aloft.

\*With so much at stake and so much tough competition, many fliers were off on the side fine-tuning their equipment, mak-

*Continued on page 66*

# RAMBLIN' AROUND AUSTRALIA

By STU RICHMOND. . .Stu takes us ramblin' across the water from Oz to New Zealand to visit the sheep and some friendly modelers this month. A nifty aerial camera in an R/C model gives us a bird's eye view.

• If you like to go flying early in the morning, you ought to live in Gisborne, New Zealand, down under near Australia. That's where my college buddy, *Model Builder* reader Bill Cooksey, lives. Gisborne is the first city in the world to greet the new day's sunrise—the International Dateline goes just east of Gisborne in the South Pacific

Ocean.

Bill had gotten an invitation to me to come visit. The Auction Evening at the Australian Nats gave me an unexpected cash windfall which just about covered the air fare for the 4,000 miles round trip. I had a wonderful visit in one of the world's greatest island paradises, with model

builders.

Next month we travel to another modeling area, make like Walter Mitty in a Tiger Moth and continue looking down to avoid the sheep dip in New Zealand, as we find more true international friendship among model builders. •



Bill Cooksey, Bob Main, Stu, and Reg Pocock with Bob's 11-foot span R/C camera plane. Bob flies this original design with an HP 120 inline twin. The hole in the fuselage side below the windshield is where the auto camera mounts.



New Zealand has more sheep than people. They graze the flatlands, and keep the grass almost short enough for R/C flying. Nature's lawnmowers! These sheep didn't want any close up photos taken.



This is the Gisborne, New Zealand model airport from about a 500-foot altitude. Stu is wearing the light colored shirt.



From a thousand feet this is the coastal area of Gisborne. Lots of flatlands and mountains. South Pacific ocean is in the background. Bob's camera uses 100 speed Fuji film. He climbs to altitude, retards the throttle to low idle to minimize vibration, and servo actuates the camera.

# ELECTRIC POWERED AIRPLANE KITS

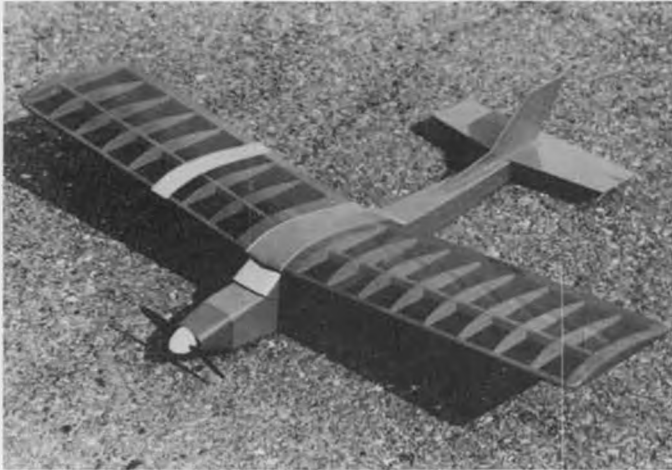

## THE ASTRO SPORT

The Astro Sport is a cute little high wing sport trainer that is specially designed for schoolyard fun. Install the Astro Cobalt 020 Motor and you have a gentle and forgiving trainer that is very easy to fly. Install the more powerful Astro Cobalt 035 and it becomes a real schoolyard show-off doing snappy rolls, loops, and other schoolyard maneuvers. The kit contains all machine cut and sanded parts and is super easy to build. Wing Span 37 inches; Wing Area 292 sq. in.; Eppler-195, Flying Weight 22 to 28 ounces. Kit # 1019 ..... \$ 39.95

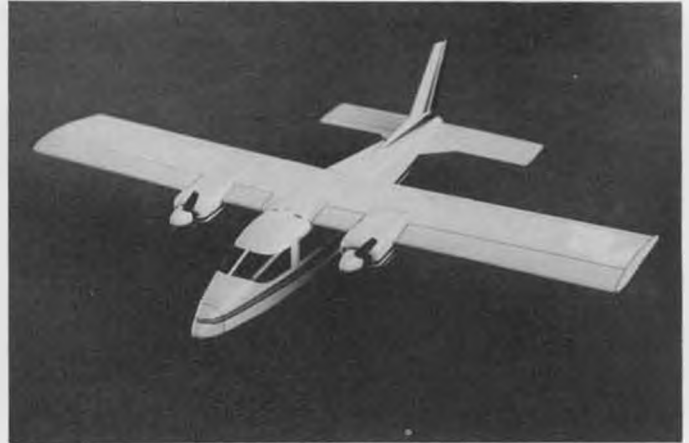

## PARTENAVIA P-68 VICTOR TWIN

Our popular PARTENAVIA P-68 kit has been completely redesigned for the Astro Cobalt 05 Motor. The airfoil section has been changed to the Eppler-195 for improved aerobatic performance. The P-68 has always been a popular model at our electric contests, and in fact an Astro Cobalt 05 powered P-68 won first place in aerobatics at the 87 EAA Electric Championships. The deluxe kit features all machine cut and sanded balsa parts. Wing Span 50 inches, Wing Area 400 Sq.In., Flying weight 4.5 lbs.

Kit # 1013.....\$89.95

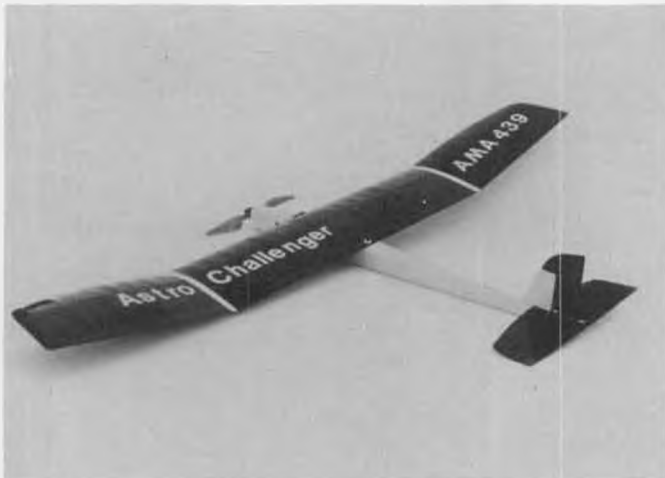

## THE ASTRO CHALLENGER NATS WINNER

Bob Boucher's Astro Challenger won the 84 Reno Nats its first time out and has been winning electric sailplane contests all over the country ever since. Powered by an Astro Cobalt 05 Geared Motor turning a 12 inch folding propeller, the Challenger climbs almost out of sight in 45 seconds, and can repeat this climb three or four times on a single battery charge. The distinctive wing planform with elliptical tips maximizes aerodynamic efficiency and minimizes tip stalls. It's gentle and forgiving nature make it perfect for beginners too. Kit features all machine cut and sanded balsa parts. Wing Span 72 inches, Wing Area 612 sq.inches, Airfoil Eppler 193 Flying weight 39 ounces. Kit#1020..... \$ 49.95



## THE PORTERFIELD COLLEGIATE

The Porterfield Collegiate makes a great sport scale electric model. It's gentle and forgiving nature make it perfect for beginners, but at the same time it can be quite responsive in skilled hands. The large wing and light wing loading lets the Porterfield climb steeply to and land short. Just what you need for flying in your neighborhood park or schoolyard. Beginners to R/C should install the Astro Cobalt 15 Geared Motor. More experienced flyers can install the Astro Cobalt 25 geared motor for very realistic scale like maneuvers. Wing Span 69.5 inches, Wing Area 690 sq inches, Airfoil Eppler 193, Flying Weight 4 to 5 lbs.

Kit # 1018 .....\$ 79.95

**ASTRO FLIGHT INC.**

13311 BEACH AVE. • MARINA DEL REY, CA 90292 • PHONE (213) 821-6242





Free  
Shipping for  
orders over  
\$150.00

No service  
charge on credit  
card orders

# NORTHWEST

## H o b b y S u p p l y

Premier  
Competition Hobby  
Shop

A Division of Hobby Town  
Inc.

Pylon Racing  
Specialty  
Outlet

### 2 CYCLE ENGINES

	Retail	Sale
<u>O.S.</u>		
.25 FP	94.95	53.50
.40 FP	104.95	56.50
.40 SFABC	199.95	109.50
.46 SFABC	219.95	122.50
.61 SFABC	294.95	162.50
.40 VR-P G	229.95	129.50
<u>SUPER TIGRE</u>		
S-.25 ABC	124.95	69.98
S-.40 ABC	154.95	92.98
S-.45 ABC	159.95	94.98
S-.61 ABC	219.95	117.98
X-.40 PYLON	179.95	119.98
G .40 Sport	119.95	69.50
6-.49 Sport	129.95	70.50
ST-.60 C/L Stunt	169.95	84.95
<u>ROSSI</u>		
.40 ABC	199.95	117.50
<u>FOX</u>		
.40 R/C BB DLX	109.95	64.98
.35 Stunt	44.95	26.98
<u>K &amp; B</u>		
.20 Sportser	62.00	36.98
.45 Sportser	64.00	37.98
.65 Sportser	99.95	59.98
.40 R/C BB	100.00	58.98
.61 R/C BB	120.00	69.98
.15 BB Conquest	82.50	48.98

### 4 CYCLE ENGINES

	Retail	Sale
<u>SAITO</u>		
FA 45	169.95	129.50
FA 50	199.95	152.98
FA 65	229.95	169.95
FA 80	264.95	*191.95*
FA 90T	469.95	364.98
FA 120S	399.95	289.98
<u>O.S.</u>		
FS 40 Surpass	259.95	129.50
FS 48 Surpass	299.95	156.50
FS 91 Surpass	399.95	223.50
FS 120 Surpass	549.95	309.98
<u>YS</u>		
120 FS	523.95	357.98

Tacoma, WA 98444

### The

### Edge (from Paragon Model Products)

Quickie 500 Racer  
Holder of the N.W. Quickie 500 Record  
Fiberglass and Foam Kit  
all wood included

**\$79<sup>95</sup>**

### Radios

	Retail	Sale
<u>FUTABA</u>		
2NBR	114.95	63.95
Magnum Jr/Stid	159.95	86.95
4NL Conquest w/3	234.95	109.95
5 NLP PCM/Stid	419.95	234.95
6 NL Conquest/VAM	294.95	161.95
6 NL Conquest/FM	309.95	180.95
7 FGK/FM	429.95	209.95
7 FGHI/S-130	519.95	252.95
6 FGK/AM	345.95	186.95

For immediate shipment:  
National Watts (includes WA):

**1-800-541-0645**

Information & local residents  
(206) 531-8111

### Hours:

Mon to Fri 10:00 to 8:00 PM  
Saturday 10:00 to 6:00 PM  
\*\*Sunday 12:00 to 5:00 PM

(Pacific Standard Time)

Mail checks & money  
orders to: Northwest Hobby  
Supply

P.O. Box 44577  
Tacoma, WA 98444.

### KITS

	Retail	Sale
C G Electra Dix	69.95	38.95
Midwest Aerostar .20	59.95	38.95
Midwest Aerostar .40	84.95	55.95
Midwest Super Hots	89.95	58.95
Prather Lil Toni QM	109.95	85.95
Prather Lil Toni F1	145.95	113.95
Sig Banshee C/L	34.95	22.50
Sig Super Chipmunk C/L	55.95	35.95
Sig Magnum C/L	79.95	51.50
Sig Spacewalker	300.00	*192.00*

### Starter Package

Midwest Aerostar .40 Trainer  
O.S. max .40 FP engine  
Futaba Conquest 4NL w/ 4 servos  
RETAIL \$464.80  
Standard Sale Price \$241.35  
**COMBO SPECIAL \$235.95**

### ACCESSORIES

	Retail	Sale
<u>PERFORMANCE SPECIALTIES</u>		
Firewall Motor Mounts		
(OS 40/45 FSR, ST40/45, OS 40/46 3F, K&B 6.5, ROSSI 40)	17.95	15.25
2" Aluminum Spinners	25.00	21.25
2.25" Nylon Racing Wheels	6.95	5.95
Axle for Racing Wheels Assbly		2.50
Air Shrink Tubing	2.25	1.90
O-Rings (10)	5.00	4.25
(Call about other PYLON RACING Accessories)		
<u>SULLIVAN</u>		
601 HTD Starter	49.95	29.95
603 Dynatron Starter	74.95	44.95
<u>SONIC TRONICS</u>		
Power Panel	44.95	26.95
12V Fuel Pump	15.95	9.50
<u>DUBRO</u>		
Kwik Klip II	5.95	3.50
Kwik Klip III w/charger	22.95	13.95
<u>GOLDBERG</u>		
Super Tote Box	44.95	26.95

Payment: Visa, MasterCard, Checks, & C.O.D. (C.O.D. charge \$3.50) Make checks and money orders payable to Northwest Hobby Supply.  
Terms: Please allow 3 to 4 weeks for checks and money orders. Visa and MasterCard will not be charged until we ship your order. Prices are subject to change.  
Authorized returns only. Returns may be subject to a restocking fee.  
Tax: Washington State residents add 7.8% sales tax.

# RELAX. WE CAN FIX IT! IT'S A STARHAWK.

The first "rookie-to-ace in eight flying days" that is ALSO repairable.

RC is suppose to be fun — not terror filled anxious moments.

Introducing the first ARF that is truly repairable — yet meticulously handcrafted, one by one, using easily repaired balsa and foam construction.

Easy to fly the first time...easy to move into aerobatics...easy to repair.



## NOTICE:

Because STARHAWKS are meticulously handcrafted they remain in limited supply. See your hobby dealer soon for delivery details.



Thorpe  
Engineering  
Corporation

1715 East Fairfield  
Mesa, Arizona 85203  
(602) 964-1398

© 1988 TECH

Model: Amy Lynn Grunewald  
Make-Up & Hair: Vince Faucy

Unmatched excellence in Design and Workmanship

# THE DU-BRO KWIK KLIP III XL

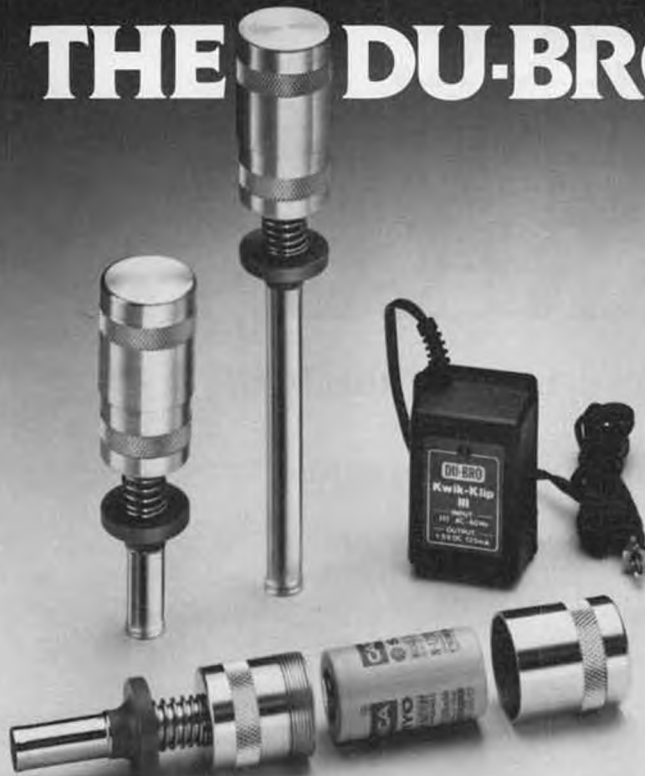

The Ultimate Glo-Plug igniter for planes, boats, cars and helicopters. Powered by your Sub-C rechargeable nicad battery, the spring loaded Kwik Klip III locks onto the Glo Plug and provides a constant power source until you release it from its duty.

For your convenience, the Kwik Klip III is available in two lengths; 1" for easily accessible engines and 3½" XL (Extra Long) for models with concealed or hard to reach engines, and provides current to standard and 4 cycle glo plugs. A 125 mA battery charger is optional and is designed to charge your battery while inside the Kwik Klip III.

It's safe, dependable and built to last a lifetime.

**"What More Could You Ask For...  
Gentlemen, Start Your Engines!"**

**DU-BRO PRODUCTS, INC • 480 BONNER ROAD • WAUCONDA, IL 60084**

## Control Line. . . Continued from page 61

ing extra test flights, or even practicing combat. Will Naemura and Granderson use simple airplanes with O.S. engines for practice matches at about 80 mph that help sharpen them for the real thing. However, the testing did see a number of airplanes folded, crashed, or otherwise sacrificed.

\*Innovations in AMA combat come slowly, as the airframes and engines have developed over the years to near the ultimate. Still, each year there is one that seems to advance the craft at least a little. This year's technological leader probably was Southern California's Steve Hills, with his new foam design with a medium aspect ratio and curved leading edge. They used a carbon fiber engine mount, tubular boom, and over-and-under aluminum bellcrank mount with homemade bellcrank. They appeared light, fast, and tight-turning with little speed loss.

\*My nomination for best match was a long cat-and-mouse game between Remy Dawson of Canada and Leonardo Silva of the Los Angeles area near the end of Saturday's flying. This pair put on one of the finest displays of combat flying I have seen, and drew prolonged applause from a knowledgeable audience.

\*Greg Wornell captured the nomination for Best Sportsman by volunteering for two rematches against Mike Petri because of various problems that seemed to recur. Petri emerged the winner in what one observer described as an "epic mini-contest," in

which Wornell flew much of the final match with one wing removed.

\*Rookie of the Year nomination goes to Spencer Sheldrew, who has flown for only one year.

\*The contest was conducted in an appropriate setting for a miniature aviation event, at the edge of an active sport airport. All day long, skydivers drifted down onto the field alongside the model contest area.

The Bladder Grabber date usually is the third weekend in June, somewhere in the suburbs of Seattle. If you've never been there, now is the time to start making plans for 1989.

I'd like to ad special thanks to Dick McConnell of Seattle and Frank Boden of Burnaby, B.C., for help in preparing this report, as I was able to attend only one day of the meet (guess why I went home early).

### NEWS FROM GERMANY

My call for mail from readers has been paying off handsomely and provides material that will make some interesting future columns. To the several who have sent pictures along with your letters, watch for them in a future issue. To others, keep those cards and letters coming.

Here's one from Sgt. Robert Jablonski of the U.S. Army:

"I figured I'd drop you a line and say thanks for keeping the CL column going in *Model Builder*.

"Also, I'd like to let you know that control line flying in Heidelberg, Germany, is taking off. After being away from CL planes for a few years (nine), last winter I decided to

build a couple of planes; a Top Flite Baby Streak and a Goldberg Lil' Satan. And I just ordered a Sig Twister and a profile Mustang from Hobby Lobby.

"And since it's kind of hard to start, launch, and fly a CL plane by myself, I got a couple of people in the barracks to join me and let them try out the Baby Streak. Now three other people in the company just ordered control line planes, and I'm thinking of running an ad in the local military newspaper to look for other CL people or people who are interested. If the response is good, I'd like to try to get a club going.

"The only problem is that the three Germany hobby shops in the area don't have any CL items except for universal stuff; i.e., fuel, props, engines, balsa. The PX over here got a shipment of six Cox CL planes, and they sold out within the week. When I asked when they would get more planes and/or kits, they said there "wasn't a demand." So, the main reason I am writing is to ask you if you have any tips on starting a CL airplane club. I'd much appreciate any tips you can tell us.

"Also, I greatly enjoyed your article on the Drizzle Circuit. It had lots of good ideas. The only thing I might change is to add a couple of classes like 1/2-A, .15, .35, and maybe .60 so that it can get all types of budgets." I would say that it appears that Robert has made some of the first steps toward starting a club and is heading about it in the right way. The best way to get a club started, in my experience, is to do a lot of building and flying, and to make friends with the

## BEGINNER TO EXPERT... KALT IS THE CHOICE



### KALT CYCLONE SUPER HELI COMBO

The Cyclone is the ultimate beginner helicopter which is as easy to build as it is to fly. Its super strong composite main frame, belt driven tail rotor, Bell-Hiller mixer, factory assembled collective pitch and rotor head can be built in 4 to 6 hours. This is a great choice for novice and expert alike.

ITEM#	DESCRIPTION	RETAIL PRICE	CIRCUS PRICE
KBHCYCLONE	Cyclone Helicopter Kit	\$299.99	\$259.99
WE1025RCH	Webra 50 Heli Engine	129.99	109.99
K01000553	Heloball Muffler (for Webra 40/50)	28.99	24.99
CH0001	Circus Super Starter	29.99	21.99
MCDRC101	NI-HL-1 Ni-Starter (w/Charger)	26.99	23.99
CH0016	12V Wet Cell Battery (5.5 amp)	19.99	12.99
CH0036A	1.5V Glow Plug	2.10	1.99
CH236	Circus Handcrank Fuel Pump	15.99	11.99
IM63003	Silicone Fuel Line (Large)	3.20	2.99
K06030302	Circus Training Gear	16.99	13.99
JRS506	JR 506 Servo (Reverse Direction)	38.99	26.99
JS6H2	Circus 6 AM Heli Radio (CH12,38-56)	226.99	169.99
HELITIPS	Circus Heli-Tips Booklet	—	FREE
SSUPERCYC	Cyclone Super Heli Combo Price	840.20	681.88

**SUPER COMBO PRICE \$600.98**

#### KALT HELICOPTERS

Manufacturers of the largest range of model helicopters in the world, with a choice of 10 models from the Baron 28 to the scale Baron 60 Longranger.

### KALT BARON 28 SUPER HELI COMBO

The Baron 28 is a great economical choice for the novice. This is a very stable, precise flying machine which will give you hours of flying enjoyment.

ITEM#	DESCRIPTION	RETAIL PRICE	CIRCUS PRICE
KBH28	Baron 28 Helicopter Kit	\$199.99	\$159.99
WE1029RHS	Webra 1029RHS Shuttle Engine	129.99	94.99
CH0036A	1.5V Glow Plug	2.10	1.99
K01000551	Heloball Muffler	25.99	23.99
CH0001	Circus Super Starter	29.99	21.99
CH0016	12V Wet Cell Battery (5.5 amp)	19.99	12.99
IM63003	Silicone Fuel Line (Large)	3.20	2.99
MCDRC101	NI-HL-1 Ni-Starter (w/Charger)	26.99	23.99
JS6H2	Circus 6 AM Heli Radio (CH12,38-56)	226.99	169.99
JRS506	JR 506 Servo (Reverse Direction)	38.99	26.99
CH236	Circus Handcrank Fuel Pump	15.99	11.99
K06030301	Circus Training Gear B-28	16.99	11.99
HELITIPS	Circus Heli-Tips Booklet	—	FREE
SSUPER28	Baron 28 Super Heli Combo Price	737.20	563.88

**SUPER COMBO PRICE \$534.91**



**JR GYRO (JRJ110BB) WHEN PURCHASED WITH EITHER COMBO - \$10.00 OFF CIRCUS HOBBIES DISCOUNT PRICE**

RETAIL PRICE	CIRCUS PRICE	COMBO PRICE
\$148.99	\$124.99	\$114.99

# CIRCUS

TO ORDER TOLL FREE 1-800-782-0022  
HOURS M-F 7:00 AM - 6:00 PM  
SAT - 8:00 AM - 4:00 AM  
PACIFIC STANDARD TIME



# HOBBIES

3132 SOUTH HIGHLAND DR, LAS VEGAS NV 89109  
PRICES SUBJECT TO CHANGE WITHOUT NOTICE

# GASP!!

PUT SOME PANTS  
ON THAT AIRPLANE!

ACE Wheel Pants that is!



BEFORE WHEEL PANTS...

AFTER WHEEL PANTS!

These wheel pants are a quick and easy way to really dress up your favorite airplane. Made from rugged .060" ABS plastic, they go together fast and paint up beautifully with any dope, enamel, or epoxy. Molded into the pant is a flat area to simplify mounting to the landing gear.

A perfect mate to Cap'n Eddy's Sport Squadron series of plane kits. Four sizes cover most requirements. Packaged as a pair.

Cat. #	Wheel Dia.	Length	Width
60K35	2 1/2"	6 3/4"	2"
60K36	2 3/4"	7 7/8"	2 1/8"
60K37	3 1/2"	8 7/8"	2 1/2"
60K38	4"	9 1/4"	2 7/8"

60K35.....	\$6.75
60K36.....	\$7.95
60K37.....	\$9.75
60K38.....	\$9.95



Complete Catalog \$2.00. If ordered direct add \$2.00 P&H. 116 W. 19th St., P.O. Box 511D8, Higginsville MO 64037 (816) 584-7121



## Hobby Horn

hobby specialties

---

*Kits from P & W Model Service*

1935 Miss America 84"	\$71 96	1936 Buccaneer 84"	\$59 96
1937 Dallaire 108"	\$75 16	1938 Clipper Mk I 72"	\$41 56
1938 Kloud King 63"	\$42 36	1938 Powerhouse 84"	\$53 56
1938 Record Breaker 96"	\$69 56	1938 Trenton Terror 72"	\$40 76
1939 Korda Wake 44"	\$19 16	1939 Mercury 72"	\$58 36
1939 Zipper 54"	\$53 56	1940 Ranger 46"	\$31 96
1940 Sailplane 78"	\$84 76	1940 So Long 50"	\$30 36
1941 Brigadier 56"	\$40 76	1941 Super Quaker 78"	\$72 76
1941 Playboy Jr 54"	\$31 16	1941 Playboy Sr 80"	\$51 16
1941 Brooklyn Dodger 56"	\$42 36		

---

*Midway Model Co.: Full Kits*

1936 Flying Quaker 84"	\$64 76	1938 Powerhouse 50"	\$29 96
1937 Long Cabin 78"	\$47 16	1939 A T Sportsar 50"	\$29 96
1937 Quaker Flash 67"	\$45 56	1940 Buzzard Bombshell	
1937 Air Chief 61"	\$35 96	72" span kit	\$56 96
1940 New Ruler 74"	\$71 16	50" span kit	\$35 96

The above kits qualify for Sam events (FF & R/C), and feature the highest quality machine cut & sanded parts, all sheet & strip wood, wire, & window material. Most plans are the original FF, but the models are easily convertible to 3ch R/C.

---

*Sailplanes, Electric Power or Gas Kits*

MIDWAY MODEL CO.		ELECTRIC MODEL DESIGN	
Gnome HLG 60"	\$24 00	Sky Knight 44" (05 DI)	\$24 00
Gnome 2M Glider 78"	\$37 96	Electra Glide 11 73" (05 D)	\$31 00
Fast Eddie (05 D)	\$24 00	Lightning 36" (05 D)	\$24 00
Ultra Mk IV (05 G)	\$37 96	Thermic Traveller (05 D or G)	\$31 00
Electric Playboy (05 G)	\$26 00		
Hobby Horn Sensor Glider 78" (or 05 electric)	\$18 00		
Astro Challenger (05 Geared)	\$32 50		
Astro Viking (05 Geared)	\$32 50		
Astro Porterfield (15 or 25 Geared)	\$59 96		
Astro Sport 37" (05 Direct)	\$29 96		
Davey's Robin (05 Geared)	\$33 71		
Davey's Le Crate (05 Geared)	\$35 96		

---

**FULL LINE OF ELECTRIC SYSTEMS & PARTS AVAIL**

<b>SHIPPING &amp; HANDLING</b>	<b>76 Page CATALOGUE</b>
Up to \$8.00 add \$2.00	\$2.00 pp/1st Class, or free
\$8.01 to \$20.00 add \$2.50	when requested with order.
\$20.01 to \$45.00 add \$3.25	
\$45.01 to \$70.00 add \$3.75	
Over \$70.00 add \$4.50	
CA Addressees add 6% tax Send MO, VISA / MC (# & Exp) or Check (allow up to 30 days for check clearance.)	
COD - Exact charges plus \$1.50 handling (Cash Only)	

**HOBBY HORN**

15173 Moran St. [B]  
P.O. Box 2212  
Westminster, Ca 92684  
(714) 893-8311  
Hrs: Mon-Fri 9AM - 5PM

people who are attracted by what you are doing. When you get that kind of nucleus in place, you can attract others by sponsoring some simple flying events, or, as you suggested, trying an ad in the paper. The advertisement might just draw out some other active CL fliers who had not been aware of your activity, and among them could be some "experts" that will help everyone progress faster. Hanging a notice or leaving handouts in the local hobby shop is a way to get to other modelers who shop in that store.

This helps to explain why you see strong, active clubs in some unusual locations. For example, I was a resident of Astoria, Oregon, a small town of 10,000 people on the northern Oregon coast, when the North Coast Control Line Aeromodelers' Society (CLAMS) was formed. It all started with a couple of guys flying together in schoolyards, then more saw the planes in the air and more heard the sound, and soon the club was active. It since has sponsored major contests and provides some of the toughest competitors on the Northwest CL aviation circuit. This story has been repeated in many places.

So, if you think you are all alone in some area where there appears to be no CL activity, you may be able to start it yourself.

Start flying regularly in a site that is visible to the public, but not too near to residents who will complain about your engine sounds. Always conduct yourself with the utmost politeness and courtesy around the public. Be quick to answer questions from

interested spectators and to show off your equipment. Have a trainer plane available to teach the most interested prospects.

Some clubs or individuals have cards printed to hand out to spectators, giving their name and phone number and the club's meeting and flying times and places.

Make sure to be visible to your local hobby shop. They may not carry CL items at first, but if you keep asking them, they will become interested. Remember, the modern hobby shop owner does not stock CL items because he does not know about the CL hobby. Your job is to inform him, in a friendly way, of what you are doing and what you need.

Once you have your club established, try to find regular meeting and flying places, and be there when you are scheduled to be. This makes it possible for others interested to find you.

Most CL clubs find it advantageous to obtain a charter with the Academy of Model Aeronautics soon after their formation. All CL fliers should be members of AMA anyway, whether they are competitors or not. AMA provides insurance, a wealth of information about the hobby through various publications and services, and provides special services to clubs. AMA also is the U.S. model aviation competition sanctioning body, and membership is required to fly in model contests.

Your AMA charter also provides you some clout in dealing with public agencies in obtaining and keeping flying sites, and AMA has a department that is devoted to such efforts. The department was instrumental in helping the Eugene Prop Spinners obtain the new site written about in this column a few months ago.

Once you get your club going and get involved with AMA, you undoubtedly will then be able to learn about other clubs in your region and may help to be the catalyst for a new emergence of your favorite hobby in a whole new area.

Most clubs have regular flying days, to which they add "fun-fly" special events with simple CL competitions designed for the novice flier. As experience grows and modelers branch out in different directions, some of these events are worth retaining.

For example, the Seattle Skyriders have a regular "beginners' day" at which they provide trainer planes and flying instruction in a city park. This is a potential source for new fliers.

In general, my advice for the beginning of your club is to keep it simple. Do a lot of flying, spend time comparing notes and building techniques, and just have fun with the hobby. You'll be amazed at how your own ideas and skills will branch out and grow.

One word in response to the remark about the Drizzle Circuit: DC fliers feel that one of the reasons for the racing series' success for the past decade has been that it did not have too many classes. One of the problems suffered by racing and some of the other CL events as well is that there are too many different classes of the same kind of event, and the efforts of the fliers are diluted. Nobody can do a good job at any one event because they're too busy flying three or four.

**INTRODUCING THE FIRST CONLEY PRODUCTION 4-STROKE**

# we're talking "DOHC 4-Valve"!

Just like "Cosworth",  
"BMW", even "Maseratti"!  
We're talking DUAL OVER  
HEAD CAM, 4 VALVES PER  
CYLINDER, 1.2 CUBIC INCH,  
WORLD CLASS POWER-  
HOUSE, HIGH TECH DESIGN,  
BEYOND STATE-OF-THE-ART  
PRODUCTION. We heard.  
We waited. And now  
we're talking CONLEY!



*Dual over  
head cams  
are belt  
driven.*

From famed quarter scale V-8 engine builder Gary Conley, comes the first in a series of high performance, precision built model engines. Designed to be a powerful, durable and low maintenance model aircraft engine, the new Conley 1.2 has features you'd expect to find only on European supercars. Like belt-driven dual overhead cams

utilizing the race-proven Cup and Disk system of valve adjustment. This eliminates less efficient pushrods and rocker arms that are forever in need of adjustment. In addition to this high tech valve train, paired hardened and ground steel intake and exhaust valves add better breathing and work in unison with a hard chrome cylinder that reduces weight and

increases engine power and efficiency.

Conley precision engines are made in the U.S.A. utilizing only standard SAE threads and are available factory direct or through select dealers nationwide.

If we're talking high performance, and American, and great R/C model engines, then WE'RE TALKING CONLEY.



See us at booth #1656

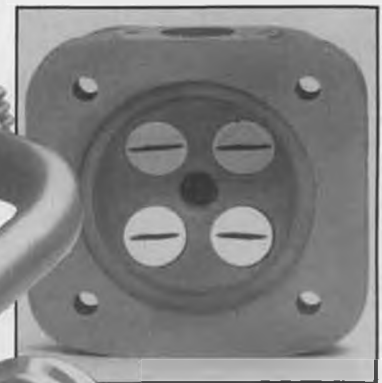

*Head boasts double  
intake and exhaust  
valves*

**Suggested Retail  
Price  
\$269<sup>95</sup>**

Dealer Direct Inquiries Invited

*"World Class Performance -*

**Conley**  
PRECISION ENGINES, INC.

*- Made in the U.S.A. -"*

820 Ridge Avenue Suite G Dept. B Lombard, Illinois 60148 (312) 953-8882

## FUEL FITTING SETS

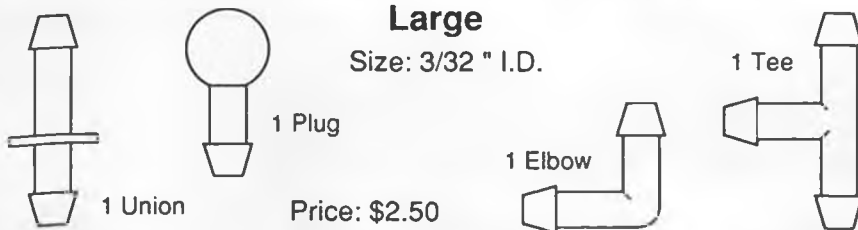

The Fourmost Fuel Fitting Sets are molded from fuel proof polyethylene.

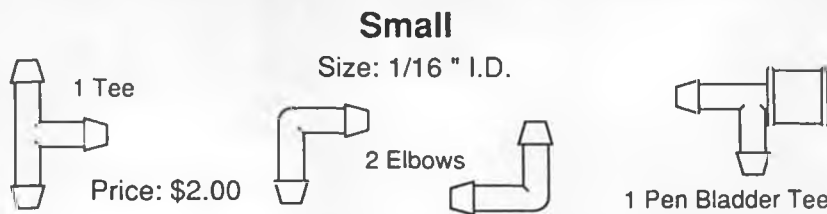

## FOURMOST PRODUCTS

4040 24TH AVE.      FOREST GROVE, OR 97116      (503) 357-2732

For success in model aviation, particularly when you're new at it, *keep it simple!*  
**NEW PRODUCTS**

We recently reported in this space the birth of a new kit manufacturing enterprise, Control Line Classics, of Anaheim, California. We now have news of more products from that company.

They have just released a kit for The Oriental, a Dee Rice stunt design from 1959. This is a full-fuselage precision aerobatics plane with a 55-inch wingspan and 550 square inches of wing, suitable for engines from .29 to .40.

Price is \$59.95 plus \$3.00 shipping, same as for the Pow-Wow, released earlier.

Later this year, possibly by the time you

read this, Control Line Classics will have produced a kit of the Buster, with 42-inch span and 395 square inches. This will be a profile that will qualify for sport racing events, slow and super-slow combat, and "nostalgia" or "classic" stunt (not Old Time).

Price will be \$29.95 plus \$2.50 shipping.

For information, contact Control Line Classics, 1788 Niobe Ave., Anaheim, California 92804.

### AUTOGYROS GALORE

In a previous column, we asked on behalf of a reader for information on CL J-3 Cubs and autogyros. To the rescue comes Robert Lane of Lake Jackson, Texas, who provides not only information but an index to maga-

zine articles on autogyros. Here's his letter:

"This is some information for Ronald Cunningham. He asked for information on control line J-3 Cubs and autogyros in your August '88 column.

"Quite a few of us keep an index to our model magazine collections. I went through my index looking for CL and R/C Cubs and gyros, finding a few. The list is enclosed.

"Piper Cubs are not a popular CL subject, there not being a single CL cub in my index. There were several R/C Cubs that could be converted to CL. Some were barely scale. Others were pretty nice. Engines ranged from .049 to .40.

"As you pointed out, many catalogs show J-3 Cub kits. An obvious choice would be the .40-size kit (#RC-3) from Sig Manufacturing, though their quarter-scale kit (#RC-48) would make a magnificent control liner for a 300-pound pilot (or use a tether). Also, John Pond has plans for more than 20 J-3s and Taylor Cubs, a considerable number having been designed for R/C. The free flight and rubber-powered designs would take a radical redesign for CL use. (John Pond Old Time Plan Service, P. O. Box 90310, San Jose, California 95109. Catalog for Piper or Taylor Cub is \$1; ask for flying scale L through Z.)

"There were four control line gyro articles and five R/C gyros. My personal preference would be the OTTO CL and the Synchro gyro R/C conversion. I'm a couple of years behind in updating my index, so this search is through September 1986.

"Since you didn't give Ronald's address, I'd appreciate your forwarding the list to him or sending me his address (*list published below—it*). If he doesn't have someone's magazine collection to browse through, have him contact me." The address is Robert Lane, 836 Sycamore, Lake Jackson, Texas 77566.

Here is the list provided by Robert:

**Piper Cubs** (All are R/C articles) -  
Simple Cub, *Radio Control Modeler* (RCM), August 1985, page 126, for .049 to .10 engines, plan #946. It has a 35-inch span, foam wing, slab balsa elsewhere.

Piper Cub, *Model Aviation* (MA), April 1983, page 22, .049 to .10, #403. 44-inch span, built up, floats shown on plan.

Taylor E-2 Cub, MA, February 1981, page 14, .049, #326. 50-inch span, built up, has Taylor rudder and cabin shape.

Taylor E-2 Cub, RCM, September 1980, page 24, .40, #811. 80-inch span, built up.

Piper Cub, *American Modeler* (AM), August 1962, page 18, .19, #862. 54-inch span, not very scale, similar to Debolt Sonic Cruiser or Live Wire series.

**Autogyros** (Control line)  
Simplified CL Autogyro, AM March-April 1965, page 18, .45 to .65, #465. Profile fuselage.

OTTO, *Model Airplane News* (MAN), January 1974, page 17, .29 to .35, #166. Profile fuselage.

Flying Banana, MAN, March 1977, page 11, .25, #277. Tandem twin rotor.

Avro C6A, MA, Jan 1981, page 37, .049, full-size plans in magazine. Profile fuselage.

**Autogyros** (Radio control)

<h3>AIR RACERS!</h3>  <p>GEE BEE R-1</p>	 <p>CAUDRON 460</p>
 <p>SEVERSKY SEV-S2 (ex. P-35)</p>	 <p>GEE BEE Z</p>
<p>1/32 scale plastic model kits of Golden Age air racers! Colorful, highly detailed miniatures. Send \$3 for fully illustrated catalog of these and other kits and accessories.</p>  <p>DEPT. MB 181 PAWNEE ST. SAN MARCOS, CALIFORNIA 92069</p>	 <p>WEDELL-WILLIAMS</p>



# 30 New Books to Help You Build Better Models

ZENITH BOOKS

**ADVANCED GUIDE TO RADIO CONTROL SPORT FLYING**  
Pratt. Scratch builders and kit builders, this book is a must for your workshop! Complete lists of the art techniques for planning, building, and flying your plane. Superb tips and tricks for construction, plus information on American Modelers Association insurance, chartering a club, and running a contest. 160 pp., 85¢.  
112988A ..... \$9.95

**BEGINNER'S GUIDE TO RADIO CONTROL SPORT FLYING**  
Pratt. A must for anyone thinking of getting started in the hobby. Completely revised! EVERYTHING the novice needs to know about building from scratch or kits. Covers building and flying trainer planes, performance planes, gliders, scale models, giant scale models, ducted fans (jets), and helicopters. 144 pp., 80¢.  
112989A ..... \$9.95

**SELECTING R/C SYSTEMS & COMPONENTS FOR YOUR AIRPLANE, BOAT & BUGGY**  
Pratt. Gives you a complete run-down of all the products on the market & helps you determine which are best for your model.  
112459AP ..... \$11.95

**HOW TO CHOOSE READY-TO-FLY AIRPLANE KITS: Making the Right Choice**  
Pratt. Analyzes all the kit models on the market & tells you which is best for your skill level.  
112491AP ..... \$12.95

**BASICS OF RADIO CONTROL BOAT MODELING**  
Finch. The editors of Radio Control Boat Modeler teach you everything about getting started. Covers gas and electric power, construction, radio gear, propellers, modifications, setting up your workshop, what to do at the lake, and racing the boat. Includes clubs. 71 pp., 130¢.  
113148B ..... \$9.95

**DESIGNING & BUILDING COMPOSITE R/C MODEL AIRCRAFT**  
Lambie. Complete guide showing how to build strong, lightweight & beautiful models. Foam, balsa, fiberglass, kevlar, polyester & epoxies.  
112492AP ..... \$16.95

**R/C DUCTED FANS: How To Build & Fly Your Own Jet Successfully**  
Fainell. An expert shows you the secrets of building your own ducted fan. Construction, finishing & flying without crashes.  
113288AP ..... \$12.95

**LEARNING TO FLY R/C MODEL AIRPLANES**  
Carroll. Detailed text & 700 illus show you every thing from the basics to advanced aerobatics. Excellent tips on all stages of flight.  
109661B ..... \$9.95

**R/C SLOPE SOARING**  
Hughes. Teaches proper techniques of slope lift, flying different types of kites, trimming the plane for aerobatics, scale designs, aerial photography, contests, aerobics, etc.  
107617A ..... \$24.95



**R/C MODEL HELICOPTER HANDBOOK**  
Lodge. In-depth guide to R/C helicopter design, including performance parameters & scratch build techniques. 196 pp., 125¢.  
107618A ..... \$10.95

**VIETNAM CHOPPERS**  
Dunstan. 200 control photos & in-depth text on scoops, slicks, gunships, heavy transports & air ambulances in action. Rates strengths, weaknesses & development. An aerial combat plus quotes from crews. 200 pp., 130¢.  
112593AE ..... \$22.95

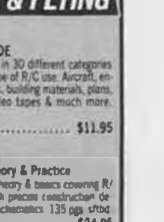

**SCHLUTER'S R/C HELICOPTER MANUAL**  
Schluter. The bible on flying R/C choppers. Basics of Helicopter Technology, Rotors & Dynamics, Flight Training, Performance Calculators & building techniques.  
10492AE ..... \$21.95

**FLYING MODEL HELICOPTERS: From Basics to Competition**  
Daly. Become a better pilot with detailed instruction on trim, advanced flying, aerobatics, competition flying & more. 192 pp.  
110761AE ..... \$21.95

**AERODYNAMICS OF MODEL AIRCRAFT FLIGHT**  
Simons. If you're building or thinking of building your own plane you must read this. No math, no formulas, just a clear understanding of what makes the plane behave and misbehave so you can be a better modeler. Includes design, props, controls, wings and more. 144 pp., 90¢.  
112668AE ..... \$18.95

**400 GREAT R/C MODELING TIPS**  
Newman. Tremendous number of tips & money saving tips on building, tools, controls, flight box & more. 76 pp., 50¢.  
111979B ..... \$9.95

**R/C BUYER'S GUIDE**  
Over 2,500 products in 30 different categories are listed for every type of R/C use. Aircraft, engines, hardware, parts, building materials, plans, field equipment, video tapes & much more. Smd.  
109373B ..... \$11.95

**CALENDARS**  
113108A ..... \$12.95



**JETS**  
A spectacular wall calendar featuring the explosive action of our finest fighters. SR-71 Blackbird, F-15 Eagle, B-1 Bomber, and many more of our toughest combat aircraft. Printed on high quality 17 1/2" x 23 1/2" paper.  
113067E ..... \$17.95

**AIR POWER**  
Furiosa. Front line fire power in color and in action. F-14, F-15, F-16, SR-71, A-6, and more. 16 1/2" x 12".  
113107A ..... \$9.95

**THE CUTTING EDGE**  
Fabulous full-color photos of hi-tech hardware in action. Truly exclusive shots from C.J. "Hester" Hester's best-selling book Cutting Edge capturing F/A-18, F-14, F-4, A-7, and more. Soar tactical aerial action guaranteed to draw a crowd! 18 1/2" x 14 1/2".  
113108A ..... \$12.95

**GHOSTS: A Time Remembered**  
The annual favorite in back again with unbelievable full-color photos of perfectly restored warbirds. Includes important dates in aviation history. Absolutely the best warbird photos around and truly a spectacular addition to your den or office. 20" x 14".  
113109A ..... \$12.95

**CLASSICS: U.S. Aircraft of W.W.II**  
Exciting full color photos deliver your warbird action. All your favorite fighters can be seen in dramatic, air-to-air photos and close up. 17 1/2" x 23 1/2".  
113088C ..... \$17.95

**LUCKY LADIES**  
The Gals Who Brought Us Home. Vintage WWII photos of the most air oriented on a variety of aircraft. Includes important dates from WWII history. 12" x 9".  
113164C ..... \$9.95

**CONFEDERATE AIR FORCE**  
An amazing collection of superb aerial photos from Bill Crump, author of the beautiful CAF book. Every month features an awesome, perfectly restored warbird in action. Includes B-17 Flying Fortress, B-24 Liberator, P-40 Warhawk, P-51 Mustang, F-4U Corsair, and many others. A must for airbird lovers. 19 1/2" x 14".  
113090AE ..... \$12.95



**SHOOTING STARS: Lockheed's Legendary F-104**  
The world's most famous and most used fighter-jet trainer. The plane debuted in 1948 and is still built and used today. Buys and models will go crazy over 122 thundering color photos showing the planes in flight and up-close in the service of the USAF and US Navy. See how the TOP GUN's started! 128 pp., 122 color photos.  
112836AE ..... \$14.95

**B-52: Aging Butts, Youthful Crews**  
Francis & Lewis. Over 100 superb color photos deliver a high flying, full-color profile of the most famous bomber to ever fly the untrodden skies. See the plane close-up, in action, and in the cockpit, plus its latest weapon - the Cruise Missile. Throw away any ideas of Greath, the B-52 is pure muscle power and payload, and these photos capture it all. 128 pp., 120 color photos.  
112993AE ..... \$14.95

**LIGHTNING STRIKES: The 475th Fighter Group in the Pacific War 1943-1945**  
Toscano. One of the very best personal accounts of WWII in the Pacific. Nearly 200 pp., wartime photos and riveting text take you into the heart of the jungles and the heat of the battle. Great shots of P-38s, nose art, and combat action. 163 pp., 184 photos.  
112471E ..... \$22.95

**AMERICAN COMBAT AIRCRAFT AND HELICOPTERS OF THE VIETNAM WAR POSTER BOOK**  
Over 100 photos and illustrations detail the planes and choppers that fought the battle to victory. Panthers, Probers, Broncos, and more in action and up close. Includes markings and color schemes. 96 pp., 150¢, 75¢ in color.  
112772AP ..... \$19.95

**APACHE: Multi-Purpose Attack Helicopter**  
An explosive full-color look at the newest, most advanced attack chopper ever built. Contains specs, history and over 100 full color photos show you the rotorcraft dedicated to destroying tanks in any environment, day or night. 96 pp., 125 color photos.  
112772AP ..... \$19.95



**ADVANCED RADIO CONTROL CAR MODELING**  
Street. Get the winning edge! This baby is packed with great tips and secrets for building and racing your cars. Includes modifications, wiring, tires, handling, gears, electronics, racing strategy, painting, and much more. Over 100 photos show you how! 54 pp., 111 illus.  
112889B ..... \$9.95

**MANUAL OF ELECTRIC R/C CARS**  
Burkshaw. Loaded with info on choosing a car & R/C equipment, painting, batteries, gear, suspension, setting up for a race, tire prep & much more.  
110681AE ..... \$14.95

**BASICS OF R/C CARS**  
E-Z techniques & handy tips you need to get started. Covers building a car, suspension, painting, modifications, batteries & chargers, radio gear, driving, competition, car care, maintenance & much more.  
110992B ..... \$9.95

**BUGGY RACING HANDBOOK (R/C)**  
Burkshaw. Cover competition, tires, suspension, available buggies, motors, speed controls, tires, radio gear & rules. Lists manufacturers & distributors.  
110968AE ..... \$13.95



**AMERICAN WARBIRDS**  
Featuring a superb collection of new color photos featuring U.S. fighter planes from WWII. The most stunning and meticulously restored planes inside and out and in rare aerial action. F4U Corsair, P-51 Mustang, F-6 Texan, P-40 Warhawk, Wildcat, Hellcat and more. 128 pp., 122 color photos.  
113019AE ..... \$14.95

**GATE GUARDS**  
Chimney. There are few air bases outside the Iron Curtain that do not have a Gate Guard posted at the entrance. They are the rufous planes that do not go to the graveyard, but are placed at spectacular angles and preserved for eternity. Over 100 incredible color photos capture a huge variety of fighters and bombers from around the country. A must for historians and modelers. 144 pp., 130 color photos.  
113238AP ..... \$17.95

**SUPER BLUE**  
This spectacular book will take you to new heights 30,000 feet! An incredible collection of full-color photos from the cockpit of F-14 Tomcats, F-15 Eagles, Migs 2000s, and Saab Viggens take you to where the air is clear and blue which few ever see. See the planes in wildest of blue yonder and close-up on the ground, plus a look at aerobatic teams including the Blue Angels and Thunderbirds. 152 pp.  
113084C ..... \$30.00

**SHOOTING STARS: Lockheed's Legendary F-104**  
The world's most famous and most used fighter-jet trainer. The plane debuted in 1948 and is still built and used today. Buys and models will go crazy over 122 thundering color photos showing the planes in flight and up-close in the service of the USAF and US Navy. See how the TOP GUN's started! 128 pp., 122 color photos.  
112836AE ..... \$14.95

**B-52: Aging Butts, Youthful Crews**  
Francis & Lewis. Over 100 superb color photos deliver a high flying, full-color profile of the most famous bomber to ever fly the untrodden skies. See the plane close-up, in action, and in the cockpit, plus its latest weapon - the Cruise Missile. Throw away any ideas of Greath, the B-52 is pure muscle power and payload, and these photos capture it all. 128 pp., 120 color photos.  
112993AE ..... \$14.95

**LIGHTNING STRIKES: The 475th Fighter Group in the Pacific War 1943-1945**  
Toscano. One of the very best personal accounts of WWII in the Pacific. Nearly 200 pp., wartime photos and riveting text take you into the heart of the jungles and the heat of the battle. Great shots of P-38s, nose art, and combat action. 163 pp., 184 photos.  
112471E ..... \$22.95



**SKAFPOWER: Modern Naval Technology of the USA and Europe**  
Over 100 color photos bring you head bating action on the high seas. See American nuclear sub marines, submarines, anti-ship cruise missiles, and mine hunters on patrol like never before. This is our front line arsenal on water complete with specifications and live-power data. Includes a description of coast, but deadly submarine warfare and the Coast Guard's war on drug smugglers. 96 pp., 125 color photos.  
112771AP ..... \$19.95

**DOUGLAS DC-3 SURVIVORS VOL. 2**  
Percy Slyfman. Skytrooper, Dakota, and Gooey Bird lovers, this is the definitive catalog listing every plane still in Santa Monica, Long Beach, and Oklahoma City - whether it's flying, in a museum, or rotting in a field. Packed with photos and history on each. 256 pp., 240 illus.  
113224AE ..... \$26.95

**MCDONNELL DOUGLAS F/A-18, MINIGRAPH NO. 25**  
Miller. Jam packed with action photos, technical data, schematics, cutaways, cockpit photos, diagrams, design information, weapons systems, markings, and more. First Hornet book to include F/A-18C, D, and DI! No other book offers this much detailed information for such a low price!  
112962AE ..... \$7.95

**WARBIRDS WORLDWIDE, NO. 4**  
The latest issue in the worldwide series showcasing vintage WW II aircraft. See perfectly restored planes, plus wartime feature articles. This issue features Mosquito and Mustang.  
112769AE ..... \$9.95

**GHOST SQUADRON OF THE CONFEDERATE AIR FORCE: Wings of Freedom**  
Crump. Breath taking color photos capture the incredible variety of perfectly restored warbirds flown by the CAF. Includes U.S. B-5s, and German bombers, fighters, and trainers flying high over Texas. Includes a brief history of each plane and the CAF. 61 pp., 122 photos, 90 in color.  
113195AE ..... \$11.95

**BELL X-1 VARIANTS, DATAGRAPH NO. 3**  
Miller. The first ever detailed look at the history and hardware of Chuck Yeager's record breaking supersonic research plane. Packed with over 200 photos and illustrations. Featuring every component of the plane, plus cockpit, engine, airframe, specifications, the variants, and more. A must for modelers and flight staff. 64 pp., 230 illus.  
113017AE ..... \$12.95

**OBSERVER'S AIRCRAFT 1988**  
Each again for another year! Every page is packed with photos, three view drawings and detailed information on performance and construction. You cannot pass up this handy "bible" to the world of aviation. 755 pp., 147 photos, 314 drawings.  
112966AE ..... \$9.95

**WARRIORS: The United States Marines**  
Von Hassel. Take the toughest of journeys as you witness the making of a Marine. An incredible 88 years - the making of Von Hassel takes you from drill field to blaring bugles and joy mountain top. Captures the rugged and raw Marine Corps training. All in highest full color. 200 pp.  
113085C ..... \$38.00

Books Shipped 10/15/88

**FLYING R/C MODELS**  
Learn how to select a trainer, size & care of R/C equipment. Take gifts and birthdays, smooth runs, maneuver, recovery from difficult situations & more! 1 hour.  
VHS 109981E ..... \$39.95  
Beta 109982E ..... \$39.95

**THUNDERBIRDS THEN AND NOW**  
An incredible video history of the legendary T-Birds and the planes they have flown. Great action footage and close-ups capture Republic F-84, F-100 Super Sabre, F-105 Thunderchief, F-4 Phantom, F-38 Talon, and the hot, new F-16 Fighting Falcon. 1 hour.  
113073E VHS ..... \$32.95  
113074E Beta ..... \$32.95

**WINGS OF THUNDER**  
Amazing footage and incredible stunts from the Blue Angels, Snowbirds, and the Raben, French and Brazilian air teams. Darsdevil stunts at incredible speeds!  
113000A VHS ..... \$14.95

**R/C VIDEO MAGAZINE, VOL. 10**  
The latest in this dynamic series. Includes ducted fans in action, detailing by master Dave Platt, giant scale B-29 Superfortress, the American Modelers Association, and 1987 Scale Masters Championships. 90 minutes, color.  
112996 VHS ..... \$37.00  
112997C Beta ..... \$37.00



**VIP'S DIRECTORY OF GIANT SCALE PLANS**  
A comprehensive directory of plans for 50 giant scale planes. Includes historic information on the real aircraft and a history of the plans. Sops with Pup, Ryan NYP, Curtiss F-40, F8F Bearcat, and many more. 116 pp., 50 illus.  
107638A ..... \$12.95

**INTRODUCTION TO ELECTRIC FLIGHT**  
Pacocek. Learn the ins and outs of clean, silent power. Details all aspects of electric R/C flight. 144 pp., 50 illus.  
112643AE ..... \$19.95

**THE COMPLETE MANUAL OF ELECTRIC PROPULSION SYSTEMS: The Quiet Revolution**  
Boucher. Packed with info on Nicad batteries, motor, motor gearing, fuel charges, motor speed controls, plans, helicopters, etc. 70 pp., 50 illus.  
107638A ..... \$12.95

**GIANT SCALE**  
A Book of Giant R/C Aircraft  
1/4 scale models! Kits, plans, props, flying skills, construction tips, radio gear & all you want to know about buying, building & flying BIG planes.  
107588B ..... \$12.95

**VIP'S DIRECTORY OF GIANT SCALE PLANS**  
deVries & Phillips. Complete descriptions and specs for 50 giant scale planes. Includes historic information on the real aircraft and a history of the plans. Sops with Pup, Ryan NYP, Curtiss F-40, F8F Bearcat, and many more. 116 pp., 50 illus.  
112907C ..... \$11.95

**Order Toll-Free 24 Hrs 1-800-826-6600**

ORDERS ONLY WI, Canada & all inquiries use 1-715-294-3345. 14 DAY MONEY BACK GUARANTEE. LIBRARY ORDERS & DEALER INQUIRIES INVITED. Items can be charged to MasterCard, Visa, American Express - Optima. SHIPPING & HANDLING CHARGES ARE \$3.95. Fee charged covers cost of shipping 4th class bookpost or will ship the best way. NO CODs. WI residents add 5% sales tax. MN residents add 6% sales tax.

**ZENITH BOOKS** Also available at fine hobby stores.

P.O. Box 11 MB118 OSCEOLA, WISCONSIN 54020

Send item number: \_\_\_\_\_ PLEASE PRINT

Include \$3.95 handling

Enclosed is my check or money order for \$ \_\_\_\_\_

Charge to my  MC  VISA  AMEX  Optima

Acct. # \_\_\_\_\_ Exp. \_\_\_\_\_

Cardholder's Signature \_\_\_\_\_

Name \_\_\_\_\_

Address \_\_\_\_\_

City \_\_\_\_\_ State \_\_\_\_\_ Zip \_\_\_\_\_

MB118

Prices subject to change without notice



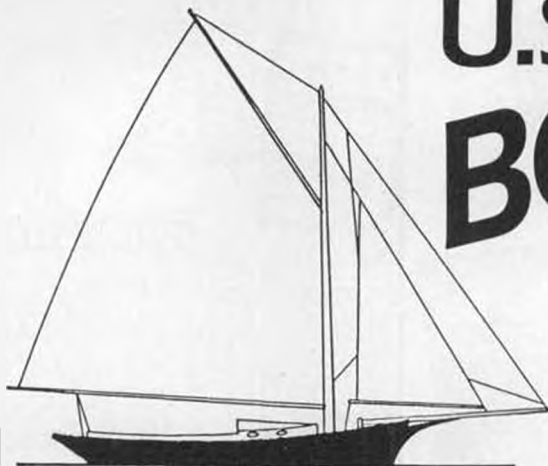

# U.S. BOAT & SHIP MODELER

THE **COMPLEAT** MODEL NAUTICAL PERIODICAL

The REAL how-to magazine on all types of model boats and ships; R/C, steam, electric, sail, racing, sport, static and operational scale. Also construction articles on all types, with full-size plans and patterns available, complete with reprint of building instructions.

**SUBSCRIBE NOW (Starts with next published issue).**

U.S. Only (includes APO and FPO): One year (4 issues) - \$12.95  
Two years (8 issues) - \$24.85

Overseas (also Canada and Mexico): One year only - \$21.45 includes postage & handling. Payment must be in U.S. funds, drawn on a U.S. Bank.

Name \_\_\_\_\_ Sig. \_\_\_\_\_

Address \_\_\_\_\_

City \_\_\_\_\_ State \_\_\_\_\_ Zip \_\_\_\_\_

Visa or MIC No. (Add 5%) \_\_\_\_\_ Exp. Date \_\_\_\_\_

*BACK ISSUES AVAILABLE - Limited supply. \$4.00 per copy. U.S. add 50¢ per copy, outside U.S. add \$1.50 per copy for shipping.*

**U.S. BOAT & SHIP MODELER, 898 West 16th St., Newport Beach, CA 92663**

Focke Achgelis 61, *Model Builder (MB)* April 1975, page 7, .29 to .40, #4751. Scale, side-by-side twin rotor. See also: *MB* November 1977, page 15, and *MB* May 1988, page 12.

Debolt Autogyro, *MAN*, September 1977, page 34, .35 to .46, #296. Has wings plus rotor.

Super Libelle, *RCM*, November 1977, page 56, .19 to .35, #708. Dula con-ter-rotating rotors.

Rotoruta, *RCM*, January 1978, page 33, .049, #714. Side-by-side twin rotor.

Synchro gyro, *MB*, September 1979, page 16, .35 to .40, #9791. See also *MB* March 1980, page 9.

Bob Lane is newsletter editor of the Brazoria County Modelers Association in Lake Jackson, Texas. Club president is Russell Moy.

As always, I welcome your letters and photos. John Thompson, 1505 Ash Ave., Cottage Grove, Oregon 97424. •

**Pattern. . . . .** *Continued from page 17*

until the model is a little touchy at full speed, then I adjust the exponential to get a soft feel at full speed. This allows the model to remain very maneuverable even at low speeds—not very scientific but very effective.

"You don't use rate switches?"

"Bluto, I've always felt dual rate switches were a stopgap engineering idea. The ideal setup for me is a transmitter which can have

the control response tailored to suit me."

"Explain, Dick."

"Okay. I like the responsiveness of each primary control (aileron, elevator, and rudder) to be similar at all speeds. Some dithering with the exponential controls and total throw setting achieves this if the model is balanced to suit me. During most flying of the model, the transmitter sticks are usually moved less than 50 percent of their allowable throw. At about 50 to 75 percent of stick deflection, my radios shift from low to high rate; the manufacturer calls it 'exponential' control, but it is really a hi-lo with a smooth transition. In actual practice it works very well.

"During slow speed flight I simply use more stick throw, and the 'expo' provides the extra throw."

"Dick, I tried expo once and the model was really weird. I don't think it's for me."

"Bluto, I think you, as many others did, tried expos that were set up very badly. A good expo system allows you to tailor the 'feel' of the model and really makes for smoother flying. Soon more manufacturers will be offering transmitters with elaborate micro processors which allow very exact tailoring of the exponential functions.

"Radio manufacturers want you to buy their systems, so they are taking advantage of the latest chip technology.

"The only negative side of all this new technology is that the typical old tinkerer cannot repair, much less understand these new systems."

"Dick, I heard that your first radio was a kerosene system."

"Very cute, Bluto. Actually it ran off a water wheel, but any blacksmith could fix it. Anyway, I prefer not to live in the past and actually enjoy learning to use the latest equipment provided. I can afford it!"

"Dick, will one of these super systems let me set up for inverted hands off—"

"Bluto, for the last time: *Forget it!*" •

**Simply Scale. . .** *Continued from page 25*

called upon to move it. There will also be more of a response lag to control as well as an overcontrol tendency when attempting to stop the wing with opposite aileron.

Always keep the wingtips light. You can do this by choosing the lightest wood for outer wing ribs, hollowing out wingtip blocks, omitting webbing for the outer 1/3 of the wing spar, moving the aileron servos closer to the center of the wing, or using a single servo for ailerons. Keeping the extremities light in a model will enhance its stability, sensitize its controls, and reduce overcontrol tendencies.

If the tail is kept light, it will, of course, reduce the need for ballast in the nose. The same effect on the model is seen in the pitch stability and sensitivity of the model. Sometimes a model will come out nose-heavy. It will be far better to try to reduce weight in the nose than to add weight to the tail. Reducing weight in the nose is even preferable to moving the battery pack aft.

**NEW!**

## ELECTRIC **EINDECKER**

Buzz the skies in search of the RED BARON with DSC's neat little stand-way-off scale model of the famous WW1 fighter.

Do take-offs, aerobatics and touch and goes with this 40" span, 275 sq. " area beauty on 6 or 7 cells.

Simple and quick to build with the precut fuselage sides and tail feathers. The combo includes the DSC HYPERTHRUST 075 motor, fused switch harness with tamiya connector, propeller adaptor and propeller and the kit!



30 ampere meter to determine current draw of any motor/propeller combination.



Special Combo Price

**\$47<sup>95</sup>**

**DAVEY  
SYSTEMS  
CORPORATION**

675 TOWER LANE  
WEST CHESTER, PA 19380  
215-430-8645

Adding mass to the tail to compensate for a nose-heavy condition will increase the overcontrol tendency and reduce stability. This distribution of mass in a model is most often overlooked by scale modelers. Many of us do try to keep things light, but we often do not pay attention to where the mass we do need is located.

Of course, every effort must be made to balance the model properly, and this must be done at all costs. Just remember to try to achieve a good balance through removing unnecessary mass rather than just bolting on some lead somewhere.

So there now, you have something else to think about during the construction of your next project.

Just remember: Keep it light and keep it simple. •

### **The Whisp . . . Continued from page 14**

edges so that they are exactly the same. Glue the 1/8-inch square balsa longerons to the sides, being sure to make a left and a right side. Before you glue in the bulkheads (F-1, F-2, F-3), check to make sure your servos will fit. The receiver and 255 mA battery should be no problem. I used a standard four-channel Futaba receiver and had plenty of room. If your servos are too wide, just make the bulkheads a little wider.

Glue bulkheads F-1, F-2, and F-3, and the 1/16-inch balsa finger box to the right fuselage half, making sure they are nice and square. Take care to notch F-3 for your con-

trol cables. Taper the rear end of the longerons so the fuselage sides just meet. Drill the sides for your control cables, and, if everything looks nice and straight, glue the fuselage sides together. Then, sheet the top and bottom of the fuselage with 1/16-inch balsa cross-grain, making sure to leave a big enough hatch to get your battery and receiver in. Finally, glue on the nose block and sand the fuselage.

Now, let's get to the wings. First, cut the ribs out of the 1/16-inch balsa. Pin them together and sand them to exactly the same shape. Then take your razor saw and cut the notches for the spars. While you have the saw out, cut the two polyhedral braces and dihedral brace out of 1/16-inch plywood.

To build the center section, pin the 3/16 x 1/4-inch balsa leading edge, the 1/2 x 1/8-inch balsa trailing edge, and the 3/32 x 1/4-inch spruce spar over the wingplan. Fit in the bottom 1/16-inch balsa sheeting and glue it in place. Trim the second rib to allow for the 1/16-inch sheeting (top and bottom) and glue ribs two through seven in place. Now, carefully fit the 1/16-inch balsa shear webs in between ribs two through seven. Glue the 3/32 x 1/4-inch balsa turbulator spar in place and set the center section aside so we can start on the tip.

Pin the 3/16 x 1/4-inch leading edge, the 3/32 x 1/4-inch balsa spar, and the 1/2 x 1/8-inch balsa trailing edge over the plans. Starting with the second rib from the polyhedral joint, glue all the ribs in place. Add the 1/16-inch balsa shear web between the second

and third ribs from the polyhedral only. Now, add the 3/32 x 1/4-inch balsa top spar and the turbulator spar.

Join the center panel and tip. To do this, you must block up the tip three inches at the end rib and carefully fit the 1/16-inch ply polyhedral brace between the top and bottom spar. Use your sanding block to ensure that all the spars and polyhedral brace fit perfectly. Glue the center section and the tip together. Fit the two ribs at the polyhedral joint and glue them in place. (You will have to cut them in half.) Don't try to save weight here by using only one rib; it weakens the joint considerably. Build the other wing the same way.

Now, carefully fit the two wings together. Block one panel up 2-1/2 inches at the polyhedral joint and join them in the same manner as the polyhedral joint. Carefully sheet the top of the wing with 1/16-inch balsa one rib out from the center in both directions. Glue a soft balsa block to each wing tip and sand the wing to the profile shown on the plans. Hang in there! We're almost through.

Cut the two elevator halves, the stabilizer, the fin, and the rudder out of 3/32-inch balsa. The lightening holes are optional but they are recommended, especially if you use a mini-receiver and/or a 100 mA battery pack, or you may have to weight the nose considerably. Glue the elevator halves together with a 1/8-inch hardwood dowel, as shown on the plans. Make sure that the forward edge is straight and that both halves are on the same plane.

## "RAINBOW RUNNER: PURE PERFORMANCE"

The Rainbow Runner delivers total pattern performance in .25 and .45 sizes. Designed with all the features of a pattern champion, the Rainbow Runner is ready to meet and exceed all your expectations.

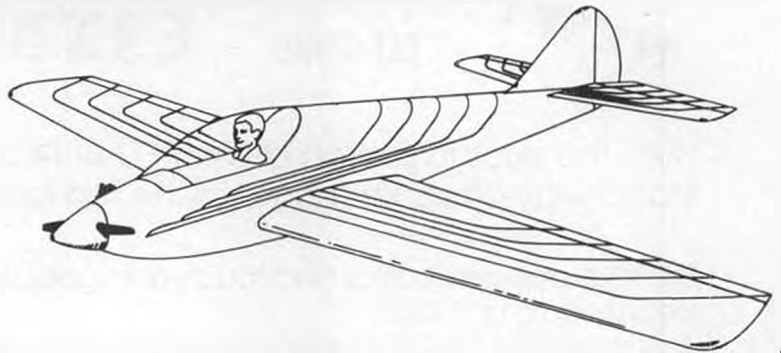

**Gm** PRECISION  
PRODUCTS INC. (714) 592-5144  
510 E. Arrow Highway, San Dimas, CA 91773

## HAYES WHIP ANTENNA

Vertical whip antenna replaces any 18 or 36-inch antenna for boats. Connect and horizontal safety ball all stainless whip only 1/32 minimum wind Available local

replaces any receiver R/C cars and tors, vertical mounts and included. spring steel diameter for resistance. at your dealer.



**HAYES PRODUCTS**  
14325 Commerce Wy.  
Garden Grove, CA 92643

Now, MonoKote the fuselage, the stab. elevator, and the fin/rudder combinations. Use MonoKote for the hinges. Make sure to leave bare spots for gluing the stab. to the fuselage and the fin to the stab. Glue the tail feathers in place.

Carefully drill a 1/8-inch hole in the middle of the leading edge right at the dihedral joint (see plans). Glue in a piece of 1/8-inch hardwood dowel in the hole with the end sticking out about 3/8 inch. Now carefully fit the wing in place and drill a matching hole in F-2. Drill another 1/8-inch hole in a small scrap of 1/16-inch ply to reinforce F-2. Fit and glue it into place.

Fit a small plywood shelf between the fuselage sides just forward of F-3. With the

wing in place, drill a 3/32-inch hole through the wing and the plywood shelf. Fit a 4-40 nylon bolt and a blind nut to hold down the trailing edge of the wing to the shelf. All that is left is to cover the wing and to install the radio. Shoot for about a 7/8-inch throw in the elevator and a 1-5/8-inch throw in the rudder.

### FLYING THE WHISP

After making sure that the center of gravity is where the plans show, gently test glide and trim as you would with any glider. Once you are satisfied that everything is trimmed, try some high-performance launches. Place your finger in the hole at the bottom of the fuselage and launch straight forward and up about 30 degrees. Launch it hard and into the wind. Keep your arm as straight as possible to avoid any injury to your shoulder. The Whisp should curve until it is almost vertical. Just before it stalls, level out and go off in search of lift.

I hope you'll enjoy your Whisp as much as I enjoy mine.

### Big Birds. . . . Continued from page 11

watched as a fellow tried to fly a 2000 with the center of gravity located as indicated on the plans. The plane leaped into the air, the nose came up, and left and right snap rolls commenced. Good buddy, Wally Parrish, saved the day with some outstanding flying.

We used this tried and true method to get the correct center of gravity: First we found the side view fuselage center line. We then used a square to draw a perpendicular line up to the leading edge of the top wing, then another perpendicular line was drawn from the fuselage center line down to the trailing edge of the bottom wing. This established the mean chord of the two wings. The CG may be placed at 25 to 30 percent of the mean wing chord, and you may expect a straight-wing biplane to fly very well with this CG. The Behrens Travelaire 2000 has proven to be an excellent flyer with a robust structure. Several of us have looked over the 2000 and 4000 plans and feel that somewhere along the line a typographical error has moved the center of gravity.

The third plane I personally have experienced difficulty with is the Lance standoff scale P-40. My P-40 has proven to be a pretty rugged customer and flies like a giant pattern plane; however, on my first flight, the horizontal stabilizer broke in two. I was able to nurse the P-40 down, but it was

pretty hairy for a few seconds. The fix was to build a new stabilizer of 2- x 3/16-inch sheets with glass cloth laminated between them. I have heard that at least two other planes experienced the same difficulty.

A lot of you are excellent test pilots, and that is very beneficial to beginners and other modelers who would rather have someone else test-hop their new plane. One way to insure a successful test-hop is to visit the plane to be tested while it is still under construction and examine the plans with the builder. It is also a good idea to check out the plane's center of gravity before it ever leaves the shop. Then if something is amiss, it can be corrected easily and no one is tempted to give it a try despite a marginal center of gravity.

It is always an excellent idea to prepare a checklist to help in your preflight. I was pleased to see several of the other Big Bird columnists starting to encourage their use. After all, it is pretty embarrassing to take off with your receiver switched off or only have two ounces of fuel in your tank. A checklist is even helpful in getting all your flying equipment in your vehicle so that you do not drive out to the flying field and find that you have left your transmitter or some other essential piece of equipment at home.

How often have you gone to the flying field and found your frequency tied up by someone who has not prepared his plane properly? This fellow has disassembled his plane and has it lying in pieces all over the pit areas, and he has the pin. I would say that if your maintenance requires more than five to ten minutes with the frequency pin tied up, then it might be an excellent idea to pack it up and do your maintenance at home in the shop. Most people get more and more upset as they scurry about trying to solve their problem. If they do finally get things going, their frustrations carry over into their flying, and they do a poor job of flying even to the point of smashing their plane. Frustration is a plane killer.

When you experience radio difficulties in flight, when do you quit trying to fly your plane? Some folks give up when they still have several hundred feet of altitude remaining. I belong to the school that white-knuckles it until there is nothing left but a pile of sticks. Many a good plane has been crashed when the R/C pilot gave up trying to fly it too soon. Most people who have been in this game for a while would advise you to stay with it as long as there is altitude.

Al has mentioned before that he did not appreciate the fact that other people writing about models refer to radio control modelers as Big boys and their toys. I do not appreciate it either because elsewhere in the world radio control model fliers are pretty well thought of and treated respectfully. Radio control flying is considered a sport, akin to other sports such as cycling and hang gliding. That is seldom true of the press here in the United States. These so-called journalists find it difficult not to hang the "Big boys, little toys" sign around our neck.

I feel this happens because several of the model magazines that are thinly disguised mail-order catalogs continually keep this cheap shot alive by running it in their pages. If someone such as myself takes them to task for it, we have the "poor sport" sign hung around our neck and are accused of trying to squelch the free press.

Recently, an Air National Guard F4 was flying at 2000 feet around the Tacoma area; the plane encountered something that flew fairly close (100 feet) past the cockpit window. The fellow in the second seat said, "Maybe it was an R/C model." The Air Force investigated the incident and sent a report to the local newspaper. Out came the scary headlines "Radio Control Models Endangering Military Jets!" This was followed several days later with an editorial that stated that big boys and their little toys should not be endangering full-size aircraft.

I spoke with the NCO of Safety at McChord A.F. Base, and the good sergeant told me that any resemblance between the Air Force report and the newspaper article was entirely coincidental.

Those of us who really care about our hobby/sport are really ticked off when we read such a report. When I have cooled down enough to write a rebuttal to the *Tacoma Morning News Tribune*, I am certainly going to try to show more class and a better brand of journalistic expertise than they deserve.

The Israeli pilots whose lives were saved by RPVs (read that R/C models) that flew interference for them in the Bekka Valley in Lebanon do not look on their compatriots as Big boys and their little toys. Nor do the power companies throughout the world that use R/C models to string power lines across deep gorges, saving the rate payers thousands of dollars by not using expensive full-size helicopters.

The U.S. Army anti-aircraft battery commanders appreciate the excellent training their gunners are receiving because R/C models that look and fly like real enemy aircraft are used as target drones, thereby saving the U.S. taxpayer untold thousands of dollars over the expense of the old unrealistic drones.

A major military contractor could not figure out why their remote-piloted vehicles were constantly going out of control. After millions were spent and the finest military boffins could not figure out the problem, then an R/C modeler was consulted. It turned out the fellows with all the letters after their names had chosen the most unstable type of plane in existence for their choice of an aerial platform.

## MAP Argus Plans & Drawings

### Plans Handbook One

Free flight plans—vintage, scale, competition & gliders.  
U-Control plans—vintage, scale & competition.  
R/C aircraft plans—scale, competition, sport & gliders.

### Plans Handbook Two

Boat plans—sport, power, sail, competition, yachts & steam.  
Car plans.  
Plans for steam, petrol & traction engines. Locomotives, buildings, cannons & clocks.

### Plans Handbook Three

Scale drawings of military, civil, private & light aircraft, as well as scale drawings of military vehicles.

Every type of plan for the scratch builder. All catalogs \$3.00 each, or all 3 for \$7.50. Specify catalog desired, and make your check payable to J.M. Lupperger Plans. California residents add 6% tax. Allow 2 - 4 wks delivery.

**J.M. LUPPERGER PLANS**  
1304 Palm Avenue  
Huntington Beach, CA 92648

## Electric Flight



Has Brake  
Lightweight 1.2 oz.  
Adjustable switching point  
Solderless terminal for easy hookup

2 month money back guarantee

**ON/OFF Controller \$24.95**

More Power, save weight  
Very high efficiency only 0.06V loss at 20 A. Size 2.2x1.3x.63

Add \$1.00 for shipping  
California residents add 6.5% \$1.63 Tax  
Send Check or money order to

**High Sky**  
3929 Kansas St. #9  
San Diego, CA 92104

Comes with Futaba connector other connectors are also available



### A Nationals Winner The "Heinkel" He 100-d 24" Wingspan — Rubber Powered Flying Scale **\$15.95** Kit #110

Your old building skills will enjoy the experience. Time too to get your son learning how. A beautiful kit in the Flyline tradition, contest winning flight ability. Decals, Canopy and Spinner are included. Quality balsa, a kit we are proud of.

We've got a whole line of old favorites. Please send \$6 for our Flyline Catalog.

Phone: (703) 273-9583 Dealers and Distributors are invited.

**FLYLINE MODELS, INC.**  
P.O. Box 2136, Fairfax, Virginia 22031

A lot of us who enjoy the privilege of flying radio control would greatly appreciate it if those of you who are Big boys playing with toys would go play golf or something; just push off! The rest of us are going to continue to enjoy our hobby/sport despite your cheap shots. We will continue to try to give R/C modeling the untarnished image it deserves.

We all have a responsibility to one another to fly safely while we enjoy ourselves flying our planes. It does not take a lot of expensive equipment, just a concern for you and your fellow flier to keep from flying over the pits and doing other unsafe things.

## Polly DT

ADVANCED HANDLAUNCH GLIDER

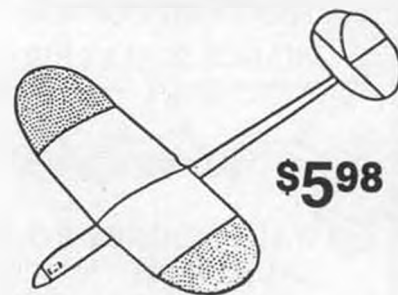

Select wood, D.T. Hardware, Balsa Fuselage, Beveled Wing. Available at your dealer.

\$2.50 shipping on direct orders.

Complete Supply of Free Flight Items & Tissue, Timers, Winders, Crochet Hooks, Front End Bearings, Pacifier Refills, Rubber, D.T. Fuse, Micro-X Kits, Cox Engine Parts

**Catalog \$1.00**

**CAMPBELLS CUSTOM KITS**

Box 5996  
Lakeworth • FL 33461

I do not know of any other pastime I would rather be doing than radio control modeling; the sense of achievement, the feeling of pride, and the camaraderie and the joy of soaring with the eagles lifts my spirits just thinking about it. I hope you folks enjoy our sport as much as I do. Good flying, till next time.

**R/C Guff. . . . Continued from page 23**

and return to the vicinity of its starting point. Its first flight took place at Kalamazoo, Michigan, in 1937.

Although numerous radio controlled flights were made in 1937 and

## NEW and IMPROVED VL PRODUCTS

### REMOTE FLIGHT BATTERIES

and Improved Motors = More Versatile Propulsion Systems

**MINI POWER AT ITS BEST** — Light Weight • Ideal for P-30 Size Models • Quick Charge  
• 7-1 Gear Ratio • Quiet • Instant Start • Low Cost Battery Power • Cleaner

#### PROPULSION SYSTEMS

**VL-111B** ..... \$24.95  
Includes HY-70B Motor, B-62 Battery, 2 Props, Charge Plug, Connector and Accessory Pkg. (with screws, spacers, etc.)

**VL-111BR** ..... \$27.95  
Same as VL-111B but with a HY-70BR Motor and Remote Flight Battery Holder.

To substitute B-63 for B-62 add \$3.00

#### MOTORS

**HY-70B** ..... \$14.95  
An improved HY-70. Features reinforced prop shaft with neoprene sleeve to engage or disengage Free-wheeling.

**HY-70BR** ..... \$17.95  
Same as HY-70B but equipped with Remote Flight Battery Holder — holder has 7/8" leads with quick disconnects. Slide battery onto holder to start motor.

#### FLIGHT BATTERIES

**B-62 2x50 mAHr 9 gms.** .... \$9.95  
Snap into place on motor to start. (No wiring required)

**B-52 2x80 mAHr 13 gms.** .... \$9.95  
Same as B-62 but with motor-run up to 1 1/2 minutes.

**B-63 3x50 mAHr 13 gms.** .... \$13.95  
More powerful. (with shorter motor-run).

**NOTE:** B-63 & B-52 both weigh the same



**VL PRODUCTS**

7871 ALABAMA AVENUE • #16 • CANOGA PARK • CA 91304

MAIL ORDERS: Add \$2.00 Shipping & Handling. California Residents add 6% Sales Tax. Send \$1.00 for Complete Illustrated Catalog.



# BAG # 6

THIRTY-SIX OF WALT MOONEY'S FAVORITE  
PEANUT SCALES REDUCED TO EIGHT INCH  
WING SPAN \*\*\*\*\* \$ 5.00 POST PAID

WALT MOONEY P.O. BOX 231192 SAN DIEGO,  
CALIF. 92123 \*\*\* FIRST FIVE PEANUT SCALE  
BAGS STILL AVAILABLE AT \$ 5.00 EACH.



**"Matched Performance System"  
for TOP PERFORMANCE**

K&B ENGINES  
Airplane Marine

K&B FUELS      K&B GLOW PLUGS  
9 Blends      4 Choices

**"Matched Finish System"  
for BEST APPEARANCE**

K&B FIBERGLASS CLOTH      K&B Micro-Balloons FILLER  
K&B SUPER POXY RESIN      K&B SUPER POXY THINNER  
K&B SUPER POXY PRIMER      K&B SUPER POXY PAINT  
K&B MIXING CUPS

**K&B MANUFACTURING**  
12152 Woodruff Avenue  
Downey, California 90241

**WE SET THE PACE!**  
Michigan's most complete supplier of model kits & accessories—if it's featured in *Model Builder Magazine* we probably carry it in stock.  
We love to help beginners as well as the dyed-in-the-wool enthusiasts. Give us a try!



MEMBER  
Radio Control  
Hobby Trade  
Association

7845 Wyoming • Dearborn, MI 48126 • (313) 933-6567  
17900 E. 10 Mile Rd. • E. Detroit, MI 48021 • (313) 773-8294  
35203 Grand River • Farmington, MI 48024 • (313) 477-6266  
105 S. Livernois • Rochester, MI 48063 • (313) 651-8842

1938, the first major public exhibition was a precisely controlled flight in which the aircraft climbed to 305 meters (one thousand feet) and descended to a smooth landing less than 30 meters (100 feet) from the judges. This was in 1939 at Detroit at the National Championships where the plane won first place in the Radio Control event.

This model weighs 3.86 kilograms (8-1/2 pounds) and is powered with a Brown Jr. 1/5 h.p. engine.

Built by Drs. Walter A. and William

E. Good, 1937.

It's hard to believe that most of those Am-broid glue joints have survived 53 years and that the Guff survived more than 500 flights!

#### LOOKING BACK

It is interesting to look back and identify the actions which were critical in those early, stumbling days of the genesis of R/C planes.

The KG model choice for an R/C test bed was a stroke of luck, although in 1936 we didn't realize it. The Grant-X wing section was thick, 2-1/4 inch depth on a 15-inch

chord, producing high lift and high drag. This resulted in a plane with a narrow speed range... mostly slow. Thus, inadvertent high speed dives were practically impossible, so the plane kept surviving the many test flights with sticky relays, run-down escapements, off-tuned receivers, and learning pilots.

The pitch stability of the KG-Guff, with that large stabilizer of almost 3 square feet, or 30 percent of the wing area, was tremendous by today's standards of 10 percent. The 10 sq. ft. wing area and the 8-1/2-pound plane gave a modest wing loading of under 14 oz./sq. ft., which is much lower than today.

Even when the plane was stalled, it would quickly damp out the gallops by itself. Probably that draggy 6-foot body with the 10- x 6-inch cross section helped with the damping too!

None of the engines we used would overpower the plane. They were the Brown Jr., Ohlsson 60, and Dennymite. All required launching assistance, usually running the wing tip. We did try a Baby Cyclone one day; it required two wingmen and still, after release, just barely maintained level, which was definitely not enough power.

A recent Guff replica by Rich Bonnell is powered by an Enya .46 four-stroke, and it does excellent takeoffs without assistance. In fact, the climb-out is so steep it takes full down elevator for a safe climb angle, and that's after raising the stab leading edge over a 1/4-inch to keep the pitch trim under control. It's been great fun flying Rich's Guff with modern R/C gear to explore the Guff's flight envelope.

We did find that the 1939 elevator is, at best, a trim tab. It needs to be doubled in area to perform usefully, according to George Gibson of Fountain, Michigan. He has built two Guffs, one in 1939 and a second in 1986.

The KG was flown only as a F/F Gas job in 1936, then got its name changed from "Gas Job" to the "RC Job" to the "RC Guff." Some confusion over the Guff name stems from the fact that there were three F/F Gas models, varying from three- to six-foot span, which also used the Guff name. The six-foot F/F Guff saw much action in 18 contests in 1938 and 1939. The three-foot one was called Guffy and was so wild it suffered an early, and probably fortunate, fatal crash.

At least all of these planes had one thing in common: they were painted International Orange, my favorite color for good visibility!

The slow, but steady improvement in the R/C receiver, sensitive relay, and escapement resulted in a relatively reliable control system. At least it was now clear that many of the flight errors were traceable more to the pilot than the equipment!

Finally, the realization that the rudder control by itself was really a good initial system and became a category by itself. Historically, the rudder-only systems placed well in the Nats right up to 1954 when the R/C event was split into the two classes of Rudder-Only and Multi-Control.

What a great enduring hobby/sport the R/C planes have become for both the builder and the pilot! And especially to the

**TEAM ASSOCIATED  
RC10**

**ROAR 1:10 NATIONAL CHAMPION  
ORRCA NATIONAL CHAMPION**



# IMPORT FIGHTER.

## THE TEAM DOES IT IN THE DIRT.

Race the car that beat the imports in the toughest kind of off-road competition.

The All-American Associated RC10 took home the gold in both the ROAR and ORRCA National Championships.

Our RC10 turned back the foreign car invasion with the same racecar technology that has kept Team Associated on top of the RC car racing world for over 15 years.

## A RACE CAR, NOT A TOY.

Sure, you've heard that before.

But Team Associated designs and engineers only model RACE cars.

The new RC10 features fully adjustable, four wheel independent suspension, an aluminum alloy monocoque tub and race-proven hardware throughout.

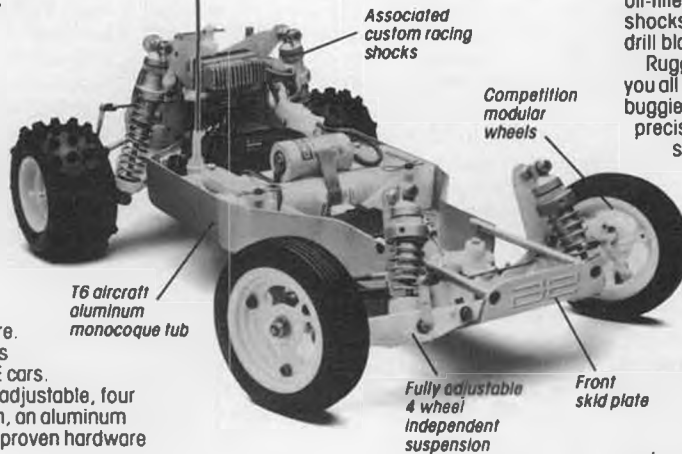

oil-filled racing shocks. These custom shocks use machined alloy cylinders and drill blank shafts for silky smooth action.

Rugged, yet light, the suspension gives you all the adjustability of full size, full race buggies. The A-arm/Ball joint design allows precise camber, caster, ride height and spring rate tuning. Even anti-roll bars and a VariLok dif are included.

Exceptional ground clearance and low center of gravity also contribute to the superb balance and performance of the RC10 over all types of terrain.

## GET THE JUMP ON THE COMPETITION.

Go RC off-road racing with the leaders. The National Champion RC10 is available now and legal for ROAR and ORRCA nationally sanctioned competition.

Complete RC10 kits, replacement parts and spares are readily available through model car racing's most extensive dealer network.

Take the challenge and build yourself a winner. Team Associated's RC10.

And the RC10 doesn't need expensive accessories and modifications to handle the roughest tracks. The strength and durability is standard equipment.

## RACE-WINNING ENGINEERING.

For maximum traction the RC10 suspension is damped by long throw,

Smooth undercarriage  
maximum ground clearance



Sealed gearbox  
VariLok  
differential

Full race rear suspension includes bulletproof half shaft and u-joints with tapered and keyed modular wheels. Quick release knock off design for fast pit work and tuning.



Model cars for Real racers.

Associated Electrics  
3585 Cadillac Ave.,  
Costa Mesa, CA 92626  
(714) 850-9342

## Leader in Small Airfoil Technology

# MASTER AIRSCREW

### CUTTING TOOLS

#### BALSA STRIPPER

Precision stripwood is easy with the Master Airscrew **BALSA STRIPPER**. Strips up to 1/2" wide and 1/4" thick can be cut quickly and accurately from sheet stock. A vernier wheel advances 1/32" per turn so that adjustment is precise. The stripper comes with a standard type 11 hobby blade and is unconditionally guaranteed against failure for five years. **\$4.95 suggested retail**



available at your dealer

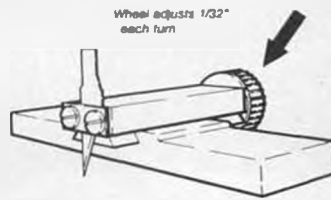

#### RAZOR PLANE

The new Master Airscrew **RAZOR PLANE** uses a heavy-duty industrial blade that is held in place by two locating screws, allowing the cutting depth to be set very rigidly and accurately. The plane has a variety of uses — rounding and smoothing contours of fuselages and cowlings, shaping edges and thinning strips, or making custom-sized strip stock. The frame and blade retainer are made of a tough Lesan® plastic and should prove almost indestructible with normal use. **\$4.95 suggested retail**

**WINDSOR PROPELLER CO.**

384 Tesconl Ct., Santa Rosa, CA 95401

many great and helpful friends encountered along the way, we extend our thanks to all of them. •

#### Insiders. . . . . Continued from page 48

For better diffusion, an overhead light or other lamp should be turned on; it's much easier on the eyes. Finishing materials vary greatly and will be discussed in a section on covering.

All in all, the above might apply generally to the construction of most any kind of balsa model airplane. Every modeler has his own way of doing things and is inclined to use some special tool or other unusual item in a way that makes for an easier and/or better end result. There are no limits; whatever works best, use it.

#### HEWITT PHILLIPS PROPOSES NEW EVENT: THE "E-33 MODEL" TO POPULARIZE MICROFILM

Hewitt Phillips, an old-time microfilm flier from Belmont, Massachusetts, and retired NASA expert, was inducted into AMA's Hall of Fame at this summer's Nats. When he makes a suggestion, it is well worth looking into. See his "What If" article on AMA Rules in August through October "Insiders." Hewitt feels that "the use of bracing has greatly increased the difficulty of construction of indoor models, as well as making them more flimsy and liable to destruction." His event, the E-33 Model, "would allow use of hollow-tube motor sticks and booms, microfilm covering, but no bracing." It is not an old-timer event, but Goldberg and Greenberg tractors from the 1934 Zaic Yearbook would meet the rules. Modern innovations, such as microfilm props and tissue wingpost tubes are okay.

In addition to AMA Rule Book general provisions, Phillip's rules are:

1. No bracing allowed on wing, stab, or fuselage.
2. Wing spars shall be attached to

fuselage at a single spanwise station on wing.

3. Wing chord shall not exceed five (tentative) inches.

4. Primary structure of balsa with no attached stiffeners or boron filament or any other material.

A five-inch chord would produce a model of about 40-inch span (rather large for many indoor sites). With no bracing, spars would have to be large enough to resist twisting.

Hewitt suggests indoor fliers try this event, and he offers to sponsor it. What do you guys think? *Your opinions are wanted!* You complete thinking on the E-33 Model! RSVP to Insiders.

#### INSIDERS WORKSHOPS

After Doc Martin of the Miami Indoor Aircraft Model Association made the suggestion that we feature photos and brief word pictures of reader workshops, we have had a good rate of return in the form of submissions. We hope you will continue to supply us with material for this popular segment of "Insiders." Send us a shot of your shop today.

We knew that the magnificent photo of John Oldenkamp in his sun-drenched San Diego shop that we featured in October would be a tough act to follow; however, the shot of the "real world" workbench sent in by Bill Warner of Santa Monica is equally good. It has all the pizzazz of Bill Northrop's and Dear Jake's benches as shown in cartoon form in the front of MB.

Warner, who is a member of the Flightmasters in Los Angeles, has these comments on his litterbug building board:

"This is what a real workshop looks like. The trouble with most of 'em you get is that someone has cleaned it up for the picture. This is unrealistic. I thought you might share with your public an *un-retouched* model builder's work space just for the record.

"There is no prize for the first reader finding the model.

"It looks worse when the high tide gets up too far." •

#### ARFs. . . . . Continued from page 33







easily epoxied together using the strong central dihedral brace, then further reinforced with the nylon fabric tape that was supplied. The next step was covering the Vector, and this is the type of model for which the various heat-shrink coverings are ideally suited. Neither Bob nor I had ever had the opportunity to try Goldberg's new Ultracote, so we thought it fitting that we give it a shot on this deserving project. Promises that this new material would be free of bubbles and sagging were quite appealing to us, so Bob got to work. Upon completing the covering job, he was very enthusiastic over how easy it was to work with. We both liked the reduced gloss which looked more realistic than other shrunk films, very similar to a nice paint job. As a matter of fact, Bob declared that from now on he intended to use Ultracote exclusively! An O.S. FSR .40 two-stroke engine dropped perfectly into the engine compartment, and my Airtronics Championship seven-channel flight pack with four standard servos were installed. Most of the necessary hardware was supplied in the kit, but we did have to furnish our own spinner, a ten-ounce tank, and three 2-1/2 inch wheels. Out came the trusty old kitchen scales, and the completed model was weighed in at five pounds, ten and one-half ounces, two and a half ounces over maximum specified weight. I don't know how to account for this, as we followed instructions exactly. Perhaps the balsa in our kit ran a bit heavier than average. A few fast calculations indicated that the model had a wing loading of 20.68 ounces per square foot, not exactly what you would call a "floater." Now we were ready to flight test the Vector, but here we ran into a slight snag. My favorite test field is a paved area about 800 by 200 feet, but for the time being it was unavailable, so flying was scheduled for a fairly smooth dirt field nearby. Radio range tests were performed, the trusty O.S. was easily started with one flip of the prop, and the Vector was taxied onto the runway. At this point I usually like to do a series of taxi maneuvers in order to see how sharp a turn can be made without scraping a wingtip, and to give the engine setting a chance to settle in before the first takeoff. However, scooting around on dirt while throwing up a cloud of dust is just too hard on model engines, so I like to get airborne as quickly as possible under these circumstances. Turning into the wind, I fed in full throttle in a smooth movement of my left index finger (I was using my single-stick transmitter), and the Vector accelerated in a straight line down the center of the runway, spewing out an enormous dust cloud behind it. A touch of up elevator and she was off the ground and climbing gracefully. At about 200 feet out and 60 feet of altitude I administered a little right aileron, but there was almost no response, just a slight dropping of the right

wing. Getting a bit worried, I increased to full right aileron throw by moving the stick all the way over, and this resulted in a very slow and sluggish turn to the right. After finally completing the intended 180 turn I decided to let her get some more altitude before attempting any further turns. This time I let her go straight at about two-thirds throttle, until an altitude of about 300 feet was reached, and I felt safe enough to try another turn. The next turn I attempted was to the left, but the result was the same, very slow, sluggish, and inadequate response. Actually, if I had to rely on ailerons alone it would have been highly difficult, if not impossible to bring her in for a safe landing. However, I next tried a couple of rudder turns and found the response to be quite good, so using rudder exclusively, I throttled back to about one-third power, lined up on final, throttled back further to an idle, and landed quite normally. My first suspicion of the cause of this poor aileron response was that I had either a servo malfunction or a binding in the aileron linkage. All checked out normal. I re-measured the aileron throws, and found that the settings were right on the recommended twelve degrees up and down. Dihedral under each wingtip was a little over an inch, but this is not specified anywhere in the instructions, because it is set automatically by the pre-cut dihedral brace. The C.G. checked out right in the middle of the recommended range at 3-1/2 inches back from the leading edge of the wing. At that point a team of aeronautical experts gathered around me and offered their unsolicited opinions. Various explanations were offered, ranging from "aileron response is reduced with flat-bottomed airfoils," to "maybe there isn't enough aileron area." In any event, I did the logical thing and substantially increased the aileron throws to about 50 percent more than original specifications. The next flight was a phenomenal improvement, aileron response was normal, neither too slow nor too fast, but just right. Stability was very good, but the Vector still is not a hands-off trainer. Loops were smooth, rolls a bit slow and non-axial, but easy to perform. Inverted flight could be held with very little down elevator, and even a degree of knife-edged flight was performed, but could not be sustained for the entire length of the field. Spins were gentle and recoveries no problem, and landings were rock steady with a long flat glide due to the lifting airfoil. Concurrently, because of the high-left airfoil there was a tendency to climb fairly rapidly under full power, so elevator trim required occasional adjustment as power changes were applied. One other characteristic exhibited in flight was the "Kwik-Fli Wiggle," a tendency for the tail to oscillate from side to side, more pronounced with increases in speed. I personally get a kick out of this, as it lends the model a note of distinction in the air, and nostalgically reminds me of many enjoyable flights with my Kwik-Fli back in the good old days.

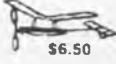
Goldberg calls the airplane a "sport trainer," and I definitely agree with this terminology as long as the emphasis is on the word "sport," and not on the word "trainer." This is a model for the intermediate pilot,

## INDOOR MODEL SUPPLY

### ENDURANCE RUBBER MODELS

<p><b>2 COPTORS</b> 12" Span \$5.95</p> 	<p><b>THE "EASY B"</b> 18" Span \$6.50</p> 	<p><b>3IMS Gliders</b> 12" Span \$4.95</p> 
<p><b>THE SLOWPOKE</b> 16" Span Weight 2 Pennys Plastic Prop \$5.95</p> 	<p><b>2 Yard Birds</b> Plastic Prop 12" Span \$5.95</p> 	
<p><b>3 Parlor Planes</b> 10" Span \$8.50</p> 	<p><b>The Novice Penny Plane</b> 18" Span \$8.50</p> 	

### NEW TOP FLYING MODELS FOR CONTEST & SPORT IN AND OUTDOORS

<p><b>20" DAPHNE</b></p> 	<p><b>EA. \$8.50</b> Drilled Nose Bl. Formed L. Gear AAA Light Sheet AAA Strip Wood Japanese Tissue Hardware &amp; Prop</p>
<p><b>22" KORDA EMBRYO</b></p> 	<p><b>20" EMBRYO SPORT</b></p> 

### 13" SCALE AIRCRAFT KITS OUTSTANDING DETAILS. 3-VIEWS & HISTORY AERONCA K 1937

**ALCO SPORT 1929** **WATERMAN RACER 1921**  
**ZIPPY SPORT A.R.V.** **HEATH PARASOL 1928**  
ea. \$8.25

272 pgs. **RON WILLIAMS BOOK ON**  
300 illust. **INDOOR MODEL AIRPLANES** \$15.95  
**INDOOR Balsa Pack** \$8.25 **P-NUT Pack** \$8.25  
**JAPANESE TISSUE** 10 lge 5 col. roll \$6.95  
**CONDENSER PAPER** 2/\$3.25 **MICROLITE** \$3.25  
**RUBBER LUBE** \$1.95 **BALSA CEMENT** \$1.95  
**THRUST BEARINGS** Mini: Dual or Dual \$1.00  
**RUBBER** .025 to .090. .005 inc. + 1/8 & 3/16 \$2.65  
**6:1 WINDER** \$5.95 **16:1 MARK I** \$12.95

WE STOCK PECK, RIN, & BROWN A-23 CO<sup>2</sup>

ADD 10% POSTAGE—MINIMUM POSTAGE \$2.00  
NEW 18-PAGE ILLUSTRATED CATALOG \$2.00

**BOX 5311, SALEM, OR 97304**

one who already has the ability to fly a basic trainer, and is ready for the next step up. Perhaps a rank beginner could learn to fly with the Vector, but this could better be accomplished if the dihedral were substantially increased (at least doubled) and the ailerons deactivated. As a three-channel model with added stability it might be possible to do some basic training, but this would only be a compromise of a rally smooth intermediate trainer. I enjoyed flying the Vector, but then again, I am no beginner. It did become evident that this is an immensely strong airplane, primarily being due to the quality construction and choice of superior materials. With any care it should last a long time, and even in case of a mishap it should be easily repairable.

The manufacturer's claims for Ultracote are essentially quite accurate. The material is extremely strong, and has thus far after about twenty flights proved itself immune to punctures and tears. The surface is completely fuelproof, and the seams appear to be highly resistant to fuel seepage causing separations. I also found that Ultracote cleans up quite easily and is less prone to retain a greasy surface after a hasty wiping-

# The Glow Plug Analyzers!

The metered NI-STARTER® from McDaniel R/C analyzes the condition of your glow plug each time you use it to start your engine. When attached, the dual-face ammeter indicates a good, marginal or failed plug. Another innovation from McDaniel R/C.

- 1650 ma/hr rechargeable battery provides 35% more starting power than regular nicads.
- Dual-face ammeter indicates plug condition when attached.



- .020" wall stainless steel tube, stainless steel spring, direct connecting high temp. teflon wiring with beryllium copper electrode. No sliding contacts to corrode.
- Positive 6-point **PlugLock**™ will not strip or wear out.
- 110V and 220V AC chargers available.

For these and other fine products from McDaniel R/C, see your local hobby dealer or contact:

**McDaniel R/C Inc.**

12206 Guinevere Rd., Glenn Dale, MD 20769  
(301) 464-2260 FAX (301) 262-4433

Visa and MC accepted.

**We take the hassle out of the hobby!**

NI-STARTER® Patent #D272901 & 4,405,890 PlugLock™ (Patent Pending)

NI-STARTER® is a reg. trademark of McDaniel R/C, Inc.

©1988 McDaniel R/C Inc.



**PECK Silver-Streak**



**035 ELECTRIC MOTOR  
SUPER LIGHT WEIGHT ELECTRIC**  
WEIGHT ONLY 2.6 OZ., USES LESS CURRENT  
LOWER CURRENT MEANS SMALLER BATTERIES  
TURNS 6-3 PROP 12000 RPM. ONLY 6.5 AMPS  
IDEAL FOR SMALL R/C & FREE FLIGHT  
FLY 30 TO 48 INCH WINGSPAN MODELS

**MOTOR ONLY \$19.95  
R/C OR F.F. SYSTEM \$62.95**



**WE SPECIALIZE IN :**  
**RUBBER POWER, CO2, ELECTRIC**  
QUALITY KITS, PLANS, TISSUE, PROPS,  
BEARINGS, WHEELS AND MUCH MORE

**CO2 ENGINES**  
TELCO · MODELA · BROWN · DAVIS

**ALSO NEW! THE "1300 R/C BLIMP"**  
**CATALOG #30 - \$2.00**

 **Peck-Polymers**  
BOX 2498 LA MESA, CA 92044  
PHONE (619) 448 1818

Electronics. . . Continued from page 16

Generally speaking, the more critical the application, the greater this sensitivity will be. In good quality meters, even those rated for higher currents are 50 uA units which have been "shunted" internally for the higher readings. We will learn just how this is done as we go along. There are less sensitive, less expensive, less precise instruments available, but their use is usually limited mostly to noncritical applications.

The other important fact that we need to know about a meter is its internal resistance. This is a relatively low value, being the actual resistance of the small wire from which the moving coil is wound. It can be insignificant in some applications, but must be taken into account in other cases, as you will see shortly. On better quality meters, this value, along with the sensitivity, will often be found imprinted on a lower corner of the face plate. It can also be obtained from the maker's data sheets. However, the cheapie or surplus meters that most of us use in our experimentation are not provided with such data, and it is up to us to obtain it.

First: to determine the meter's sensitivity. Refer to Sketch 1. Connect things as shown, with M1 being the meter under test and M2 being a known calibrated meter, such as a multimeter. Caution: in all cases, when working with unknown values, start with a high setting on your multimeters, and after an indication is obtained, reduce the range to get the greatest accuracy. For best results, solder all connections, as even the resistance of a clip can affect the readings. Remember that in most cases you are working with extremely low current values. Start with the pot set at maximum resistance, connect the battery last. Advance the pot slowly, until you start to get a reading on the test meter. Advance the pot further until you get a full-scale reading; adjust the range of M2 if necessary, its reading will be the correct full-scale sensitivity of the unknown instrument.

Got it? Good! Now for the meter resistance. Do not under any circumstances try to measure it with an ohmmeter. The ohmmeter, which we will discuss later, applies a voltage to the component under test; and while it is a relatively low voltage, it is enough to send most meters off to wherever murdered meters go. Sketch 2 now. Again start with the two megohm pot at maximum resistance, but with the smaller one at minimum. Again, advance the two megohm until a full-scale reading appears on the meter. Now, advance the smaller pot until the meter reads exactly half scale. Now disconnect first the battery, and then the 5K ohm pot center connector. With your ohmmeter, read the resistance of the pot between the terminal, with the lead still connected, and the center contact. The resistance read will also be the resistance of the meter.

In some cases, especially with the better quality high sensitivity meters, this value might be too small to get an accurate resistance with the 5K pot, and once an estimated value is known, a pot closer to it in

**CANNON** (805) 581-5061  
R/C SYSTEMS 2828 Cochran St Suite 281  
Simi Valley, CA 93065

**G-MARK R/C and U/C ENGINES**  
SUPERB, PRECISION EASY-STARTING ENGINES  
WITH TRUE R/C THROTTLE OPERATION.  
RELIABLE LO-SPEED IDLE WITH SMOOTH RPM  
TRANSITION TO HI-SPEED TOP END.

**.061 R/C** 5000 - 17,500 RPM  
 STD. GLOW  
PLUG (NOT  
FURNISHED)  
COMPLETE  
WITH  
THROTTLE

**\$49.75**  
U-CONTROL ENGINE  
(WITH STANDARD CARB) - **\$45.50**

6000 - 18,000 RPM  
**.03 R/C** INCLUDES  
THROTTLE  
 WITH  
GLOW HEAD  
& PROP

**\$46.50**  
U-CONTROL VERSION  
(WITH STANDARD CARB) - **\$42.75**

MUFFLERS ARE STANDARD WITH ALL ENGINES.  
ADD \$4.00 SHIPPING & HANDLING.  
BROCHURE - \$1.00 IN U.S.A. AND \$2.00  
FOREIGN. ADD EQUIPMENT SALES TAX IN CA.

 CASH PRICES SHOWN.  
CARDS 5% MORE  
20% DEPOSIT ON COD 

**AT LAST...**  
A Free Flight Model  
Retrieval System that  
works . . . EVERY TIME.



An ultra light weight, long range  
miniature transmitter combined with a  
**highly sensitive** receiver and directional  
antenna will quickly help you track and  
locate your plane.

**NEVER LOSE ANOTHER MODEL!**  
Send SASE For Brochure



**Jim Walston**  
Retrieval Systems  
725 Cooper Lake Rd. S.E.  
Smyrna, GA 30080  
404/434-4905

**SONG BIRD**  
Great for Thermal or Slope



Deluxe Kits with Glass Fuselage and Foam Core Wing  
**2 Meter** Plus 3.95 S&H **100"**  
**\$100.50** CA Res add 6.5% Tax **\$112.50**  
Complete Catalog \$3.00  
• Thermal • Slope • Scale • Electric •

**AMERICAN SAILPLANE DESIGNS**  
2626 CORONADO AV., NO. 89  
SAN DIEGO, CALIFORNIA 92154

up. As far as sagging goes, a couple of small sags were noted, but in all fairness, these occurred only after a lengthy period of storage in a hot vehicle. They tightened up spontaneously when the surfaces were allowed to cool off. To sum up, Ultracote is a fine plastic heat-shrink type covering which basically lives up to the claims made by the manufacturer, though it is currently off the market due to high production costs.

**ART'S HANDY HINT OF THE MONTH**

Even ARF enthusiasts periodically get their hands soiled doing light assembly work or maintenance on their models. One of the problems we often encounter is getting our fingers covered with cyanoacrylate cement. It just doesn't wash off with ordi-

nary soap and water, so many of us resort to abrasive soaps which do only a slightly better job. You can get this messy material off your hands in seconds just by running warm water over them and lightly scrubbing with a pumice stone. This stone is a spongy, light porous volcanic rock, and can be purchased at most drugstores. It works like magic and lasts almost forever.

I'm always happy to receive your comments and/or your questions about ARFs. These will all be answered personally, and those of general interest will be included in future columns. Write me at MB or 2267 Alta Vista Drive, Vista, California 92084. •

value might be used. And be sure it is a carbon pot, as low-resistance wire-wound pots are simply too coarse to be used in this manner.

Well, now we have all the vital statistics of our pet meter on hand. What are we going to do with them and with the meter? The answer is: anything we need to. With the addition of external modifications, the basic meter can be made to read any type of range of circuit information required. Since we really don't have unlimited space, let's run through the two most common uses, that of reading current and voltage.

There is one important difference in measuring of current and voltage in a circuit: for current, the ammeter has to be connected in series with the conductors; for voltage, the voltmeter is connected across the conductors. See our Sketch 3. That is the reason that most schematics and trouble-shooting data include voltage readings and seldom any currents.

Our basic 50 uA meter mentioned above can be used as is for a few applications, but it is incapable of carrying the heavier currents generally found even in low-voltage circuits, such as we use in R/C. Therefore, we have to increase its range, that is, to make it capable of carrying and indicating higher currents. We do this by adding a shunt resistor—a parallel resistor which will carry a calculated share of current, while the meter provides an indication of the total current flow. We show this arrangement in Sketch 3.

To understand shunts, one must first understand parallel resistors, which is effectively what we will have. The whole is a subject in itself; just remember that if we connect two resistors of equal value in parallel, each would carry half of the total current. If we connect resistors of unequal values, the current flow would be proportional, with the lower value resistor carrying the larger current. Like everything electronic, there is a formula for calculating meter shunt resistances:

$$R_s = \frac{R_m \times I_m}{I_{\max} - I_m}$$

Translated that means that the (R) resistance of the (s) shunt equals the (R) resistance of the (m) meter times the (I) full-scale current of the (m) meter, all divided by the (I) total current desired minus (I) meter current again.

For an example, let us again take that 50 uA meter, to which we will assign a not uncommon resistance of 2000 ohms. And let's say that we want to increase the capacity of the meter to read 100 milliamps. Thus we have:

$$R_s = \frac{2000 \times .00005}{.100 - .00005}$$

Where did all those zeros come from? Remember that in all electronic formulas, whole values must be used. Up to now, we have been working with apples and oranges and have now gone from sub-multiples (micro- and milliamps) to whole amperes. See our July column for a more thorough explanation of this phenomena!

Thanks to electronic calculators, we then have 0.10 divided by .09995 being equal to

**NEW!** Full Color Powell Gilder Flying Paper Model  
3 Pack Kit. INCLUDES: 7" F14, F15 and F16  
Cut out, fold, glue and fly—indoors or out



**KIT INCLUDES ALL THREE!**

Send \$4.50 (Includes Postage) For the 3 pack  
of Gilders and a 32 page catalog listing  
over 500 paper models to:



**PAPER MODELS  
INTERNATIONAL**

9910 S.W. Bonnie Bras Drive • Beaverton, Oregon 97005

## JET ENGINES



JET-X 50, DYNA-JET, TURBONIQUE, P-38,  
VALVES, PLANS, AND BUILDERS SUPPLIES.  
SURPLUS GAS TURBINES.

DYNA-JET ENGINE.....\$195.00  
JET-X ENGINE KIT.....\$22.50  
JET BUILDERS NEWSLETTER.....\$2/yr  
CURRENT COPY.....\$1.00  
25 PG. CATALOG.....\$5.00

DOYLEJET

4015 San Jacinto St. #A04 D  
HOUSTON, TEXAS 77004 (713) 440-4744

## "High-Amp" Powerpole® Modular "Silver Plated" Connector

Rated 30 Amps at 600 V D.C. Electrical Resistance 250 Microhms  
Color Co-ordinated (Red & Black Lexan Housing)

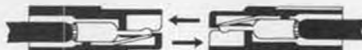

Recognized  
File No. E36226

CSA Certified  
File No. LR25154

Anderson  
Power  
Products, Inc.

Only certified checks or money orders accepted. Minimum order  
\$10.00 for three packages of 4 Powerpoles (\$3.00 per package  
+ \$1.00 shipping and handling) CT residents add 7.5% sales tax  
Prices subject to change without notice  
**DEALER INQUIRIES INVITED.** For further information and  
dealer prices send SASE and Business Card to

## SERMOS™ R/C SNAP CONNECTORS™

Cedar Corners Station  
Box 16787, Stamford, CT 06905

(203)322-6294

1.0005 ohms. In this case, we are lucky, as a one-ohm resistor is something you can buy fairly easily, and solder in place. One of the reasons is that I assigned a nice, neat, even figure to the meter resistance. It isn't always so, and so neither are the results. You will often come up with small odd values for the shunt, resistance which you will have to make!

Yes, make! How does one make a low-ohmage resistor? With great patience and, again, with that calculator. Refer to the wire resistance table furnished and mathematically work out what length of what size wire will give you the required resistance. It is usually a long unhandy piece of wire. To make it more manageable, wind it around a

# RAHM'S

## WINCHES & LINE RETRIEVERS



**WINCH \$300  
POWERFUL 12-VOLT  
F3B QUALITY  
LAUNCH A PLANE  
EVERY 60 SECONDS**



**RETRIEVER \$250  
6-VOLT  
RETRIEVE WINCH  
LINE IN 20 SECONDS**

**RAHM'S  
9309 E. Maple St.  
Bellflower, CA 90706  
Phone (213) 866-2405**

**"HOT STUFF"™**

**UFO**  
*USER-FRIENDLY ODORLESS*

**NON-FUMING  
NON-FOGGING  
WON'T ATTACK FOAM**

Bonds Foam FAST with Hot Shot™ and KICK-IT™

**ODORLESS**

**CA**  
YANOCRYLATE  
DHSIVE

*Industrial Grade*

**INSTANT GLUE**

**'THIN'**

(Red Label)

**ODORLESS - Penetrating**

CATALOG #'S

UFO-7 - 20 Gr. UFO-4 - 50 Gr.

**'THICK'**

(Green Label)

**ODORLESS - Ultra Gap Filling**

CATALOG #'S

UFO-7T - 20 Gr. UFO-4T - 50 Gr.

**"HOT STUFF"™ • American Instant Glues  
AT FINER HOBBY SHOPS**

*Satellite City*

P.O. Box 836, Simi, CA 93062  
**(805) 522-0062**

# VINYLWRITE CUSTOM LETTERING

Providing an elegant, time saving and economical finishing touch for modelers.

## • EZ TO APPLY •

Our lettering comes to you pre-spaced & pre-aligned. Saves hours of cutting & the fuss of aligning individual letters. These are not decals. Your text is custom computer cut in fuel proof premium vinyl • only 2 mil thin • vertical or horizontal text • custom lengths • 13 colors • 6 typestyles inc. Military Block • slanted or upright text • ½" to 12" high

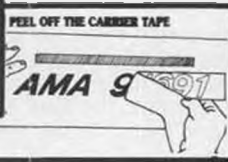

All orders processed upon receipt and shipped via first class mail.

**VINYLWRITE CUSTOM LETTERING**  
16043 Tulsa Street  
Granada Hills, CA 91344

(818) 363-7131 (between Noon and 6PM pst) • Mail order only! CA res. add tax. •

Priced right with no minimum charge!

For example, you can have your AMA number in 2" high text, any color, for only \$3.00 + P & H.

Call or write for complete info pack & sample. IT'S FREE!

Fly  
**VINYLWRITE** Custom Lettering  
on your model today!

high-value (1000 ohms) resistor, soldering the ends of the wire to the resistor leads. A thin coat of epoxy will keep the whole thing together nicely.

By connecting our new shunt in parallel with the meter, we now have an instrument that will read 0 to 100 milliamps, in a perfectly linear order.

Now, what about that voltmeter? We start off with the same ammeter, and add another resistor. Only in this case, we add the resistor in series with the meter, and we now refer to it as a "multiplier." See Sketch 3 again. Formula time again:

$$R_{mult} = V/I_m - R_m$$

In plain words: the (R) resistance of the multiplier equals the (V) desired voltage divided by (I) the full-scale current of the meter minus (R) the resistance of the meter.

Say we want to use our old friend the 50 uA 2000 ohm meter to read ten volts. We then have:  $R_{mult} = 10/.00005 - 2000$ , or 198,000 ohms. By connecting a resistor of this size in series with our 50 uA meter, we can use it to measure 0 to 10 volts. And no, you won't have to wind seven miles of #40 wire on a resistor; regular resistors can be used. Remember that resistors in series add, so by proper selection of standard values, it is possible to get quite close to any desired figure. For the best possible accuracy, the use of one-percent resistors is certainly recommended in this case.

There are other applications of the basic DC meter which I want to discuss with you, such as how we use it to measure AC, ohms, and how it is used in the R/C transmitter. I also have a couple of applications sent in by readers, but alas, we've used up our allotted space for this month, so it'll have to wait till next one. In the meantime, don't forget that any comments, pro or con, are welcome, as are all requests for information and all contributions of your solutions to any R/C electronics problems.

Oh, Yes, how about those neat schematics we've been having the past few issues? Like this month's, they are through the courtesy and skill of Miss Laura Novak, of the engineering staff of Novak Electronics.

Eloy Marez, 311 Mesa Dr., #10, Costa Mesa, California 92726. •

## Gemini M.T.S.

(A SUPERIOR MULTIPLE TASK SAILPLANE)



Standard Class R/C sailplane for sport, F3B, and AMA contests

**COMPLETE KIT WITH PRECISION CUT PARTS, ALL HARDWARE, AND FULL-SIZE PLANS**

**\$99<sup>95</sup>**

**Specifications:**  
 Wing span 100 in.  
 Wing area 930 sq. in.  
 Flying weight 44 oz.  
 Wing loading 6.8 oz./sq. ft.  
 Wing section MB-253515  
 (15% semi-symmetrical)  
 Max. ballast 4 lbs.

### Pierce Aero Co.

9626 Jellico Avenue, Northridge, CA 91325 Phone (818) 349-4758

Hannan. . . . . Continued from page 51

mined and appreciated by such European master-modelers as George Benedek, of airfoil-design fame, and Stefan Gasparin, who makes the delightfully small CO<sub>2</sub> engines and Wee R/C units. Well done, Fritz!

### SPEAKING OF FOREIGN MODEL BUILDERS

We enjoyed this quotation from the 1979 National Free Flight Society World Championship report, by Per Quarnstrom, of Sweden:

"This model is more than a model for me; it's like a good friend. When we are together, I talk to it; when it breaks, I repair the injury as good as possible.

"This is the key: you have to like your model. Then it likes you and it helps you to make the best of any situation.

"During contests, I always trim it a little, but just a little. I test it to see if it is still alive. And it is, of course."

### HOW'S THAT AGAIN?

Dave Linstrum (the Insider) sent in a tongue-in-cheek newspaper article about outdoor cooking, authored by David Grimes. Among the fuels suggested as possible alternatives to charcoal for barbecuing purposes were hickory, maple, mahogany, teak, gumbo-limbo, and balsa! Talk about expensive meals.

### GEE BEE FOR SALE

About that Gee Bee: Well, it is sort of a full-size model, originally constructed for

the 1986 Vancouver, Canada, Expo. Made of welded tubing and foam, it is presently moldering away, exposed to the elements, and could be bought for a very low price, according to artist Dick Allen who sent the photo.

### DAEDULUS DATA

In an earlier Hangar column we mentioned the epic man-powered flight of the Daedulus, which had been constructed in major part by modelers. It seems appropriate then that the first truly comprehensive coverage of the 74-mile flight has appeared in the *Aeromodeller* magazine for August 1988. Featured are marvelous detail drawings by Pat Lloyd, magnificent color (colour!) photos, and the complete story of construction, testing, and flying, authored by John McIntyre.

Quite apart from this special feature, *Aeromodeller* offers fine model construction articles, plans, and contest coverage. In the unlikely event that our readers are not familiar with this splendid British publication, may we suggest a trial subscription? The United States agent is Joseph Daileda, Wise Owl Worldwide Publications, 4314 West 238th St., Torrance, California 90505. Foreign readers may contact the publishers, Argus Press Group, P.O. Box 35, Wolsey House, Wolsey Road, Hemel Hempstead, Herts HP2 4SS, England.

### SIGN-OFF

Gerald Myers, of Redway, California, brought to our attention a quotation from



U.S. Patent # 4,660,307

**The POLISHED Approach to MONOKOTE® APPLICATION! The NEW MonoKote® HOT SOCK™**

A simple, easy-to-use cover for your iron's shoe that virtually eliminates surface scratches. It's a buffer of 100% cotton between the hard shoe of your iron and the mirrorlike finish of MonoKote.

Results? Even easier MonoKote application without hazing or scratches. New life for your old iron shoe. Fantastic on wingtips, solid surfaces ... wherever you cover with MonoKote. Only from TOP FLITE! Who else?



**TOP FLITE MODELS, Inc.**  
2635 So. Wabash Ave.  
Chicago, IL 60616

an earlier issue of *Aeromodeller*, attributed to famed French pilot/author/artist Antoine de Saint Exupery:

"Machines are undergoing three phases in their development. First they are simple. Then they get more and more complicated. In the final stage, they get very simple again." Is there a message for model builders here? •

**Peanut. . . . . Continued from page 53**  
model doesn't do anything grossly unexpected and spoil your whole day. Adjustments during this phase should be done primarily with thrust line modifications. The basic idea is to point the propeller in the direction you want the model to fly. If the model loops or climbs steeply and

stalls, downthrust is in order. If the model turns tightly to the left or rolls to the left, right thrust is in order. Here again, small, careful adjustments are the order of the day if surprises are to be avoided.

Obviously, if you are flying outdoors, wide gentle turns are perfectly okay, and often desirable. If the flying site is indoors, the model must make circles smaller than the room is wide, or the model must ultimately be built harder than the walls! (One of Murphy's more unpopular Laws!)

Indoors, careful thrust line adjustment and careful rudder adjustment also may be required to get the model to turn tight enough to miss the walls. If the model is determined to spiral dive when it's adjusted to fly in small enough circles, either the model is too big or the hall too small. Warping the wing to resist the roll may help and can be tried. Another thing that can be used is a drag flap on the inside wing. Typically, on a Peanut Scale model, the drag flap is a piece of 1/32 thick balsa, 1/4 by 1-1/4 inches long. This is cemented under the trailing edge with its long dimension spanwise and its quarter-inch dimension hanging vertically downward. Thus, it makes a little drag brake to force the model to turn without increasing the lift of the inside wing, which would tend to enlarge the circle.

The model now should be adjusted. So next, how about more duration?

A winder is a must. Indoor commercial winders, having 9 to 1 and 16 to 1 ratios are available. Outdoor winders usually have to be made from hand drills and have ratios like 4 to 1. These are used for the larger



**THE TWELFTH ANNUAL MODEL SPORT & HOBBY SHOW**

INDUSTRY MEMBERS ONLY – FRIDAY, JAN. 13, 1989, 10 a.m. - 5 p.m.  
GENERAL PUBLIC – SATURDAY, JANUARY 14, 1989, 10 a.m. - 6 p.m.  
GENERAL PUBLIC – SUNDAY, JANUARY 15, 1989, 10 a.m. - 5 p.m.

**Pasadena Center, Pasadena, California**

HOME OF THE FAMOUS ROSE PARADE & ROSE BOWL  
300 East Green Street (Corner of Green & Marengo) Pasadena, CA 91101

SEE THE LATEST PRODUCTS AND VISIT WITH MAJOR MANUFACTURERS AND DISTRIBUTORS OF:

- MODEL AIRCRAFT
- MODEL BOATS
- MODEL CARS
- MODEL ENGINES
- RADIO CONTROL SYSTEMS
- MODELING ACCESSORIES
- GIANT RAFFLE
- SWAP SHOP
- BOAT POND
- CAR TRACK

**BEST in the WEST!**

ADMISSION Adults \$5.00, under 13 - \$3.00, under 6 free if with an adult.

STATIC DISPLAY COMPETITION IN MANY CATEGORIES

SEE INDOOR R/C AIRCRAFT, BLIMP, BALLOON, CAR, AND BOAT DEMONSTRATIONS

INTERNATIONAL MODELER SHOW OFFICE: P.O. Box 10127, Costa Mesa, CA 92627 Ph: (714) 548-4700

models. For Peanut Scale 16 to 1 is just fine.

Rubber lubrication is important. It will allow you to put in more winds, and the motors will last longer. There are good commercial rubber lubes on the market. Castor oil, glycerine, and some silicone lubricants can also be used. The motor should have enough lube on it to look wet without being drippy.

Slack in the motor is important. The number of winds that can be put in a motor is proportional to its length. A long motor is not easy to wind by hand, but if you have a winder, most Peanut Scale models can use a loop of rubber that is at least twice as long as the distance from the front hook to the back peg.

Stretching the motor before you start to wind it up is important. Usually, as you start winding it, the motor should be stretched out at least five times its unstretched length. Then about half of its maximum turns can be put in. As you put in the rest of the winds, the procedure is to slowly let the motor work its way back into the model, so when you have completed the winding, the nose plug will be exactly ready for installation in the nose of the model.

Once you know about stretching, slack, lube, and a winder experimentation with the motor size and length are what will lead you to the longest possible flights with your rubber-powered scale model. Indoors, this is the only way; outdoors, there are thermals. A clever modeler will learn how to spot thermals and launch into them occasionally, if not most of the time. Rubber strip is available in a wide variety of widths from 1mm up to about 1/4 inch. For the larger models, the experimentation consists of trying longer motors and in adding to the number of loops powering the model. For smaller, indoor models, the experimentation consists of trying longer motors and in varying the size of the rubber strip used in the motor. Generally, longer loops result in longer propeller runs, but slower climbs and lower altitudes reached. This is somewhat desirable, for instance, if your model climbs rapidly and runs into the ceiling of the room; you can cure this with longer loop of motor and get a longer flight at the same time. Indoors, the ideal motor is the one that will take the model up just short of the ceiling and then let it down with the last 10 to 20 winds still in the motor. Needless to say, this may take quite a few experimental flights, but it is all fun.

It is extremely important to remember that when you change motor size, the model may have to be rebalanced if the CG is to remain in the proper place. •

#### Inside Engines. *Continued from page 41*

Although the general fits of the three .65 Sportsters I've handled are still better than the early .20 size and early .45-size Sportsters, my own .65 squeaked the least before break-in. The squeak disappears with running, and a superb piston/cylinder fit results.

It's highly doubtful that the addition of ball bearings for the crankshaft or brass/bronze bushings on the connecting rod would add anything except price to the

# Technopower's NEW BIG BORE 7

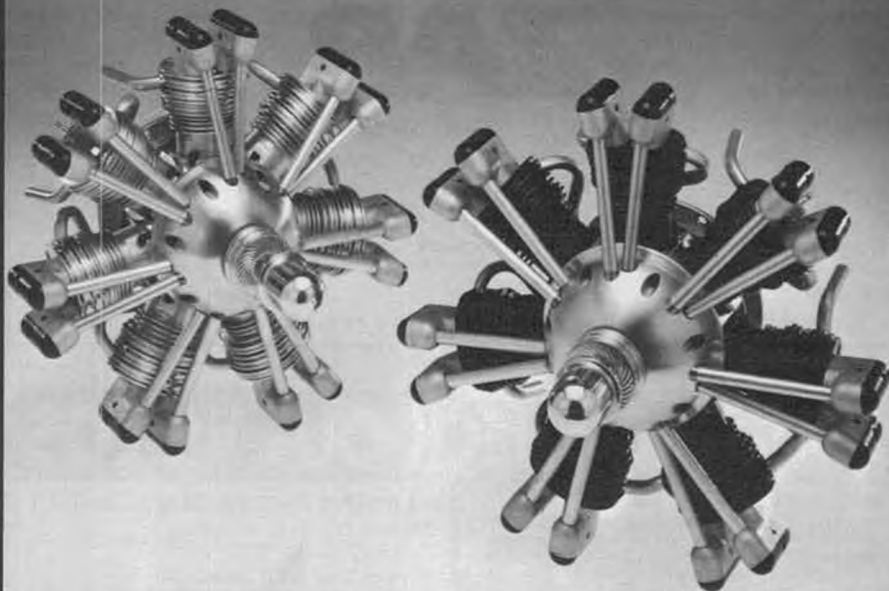

- 7 Cylinder
- 4 Cycle
- Overhead Valves
- Glow Ignition
- Displacement 2.0 cu. in.
- Red Line RPM 9000
- Flying RPM 8500
- 6-5/8" Diameter
- Hard Chrome Bore
- Cast Iron Piston Rings
- 14/6 - 16/8 Prop Range
- Extra Heavy Crank Shaft Supported By Ball Bearings Fore and Aft
- Phosphor Bronze Valve Guide

- Master Rod Runs on Needle Bearings
- Rocker Boxes Are Investment Cast. Balance of Engine is Bar Stock
- Hardened and Ground Steel Cams
- Hardened and Centerless Ground Valves
- Weight 30-1/2 oz.



FOR INFORMATION, SEND \$3.00 TO  
**TECHNOPOWER II INC.**  
610 North Street  
Chagrin Falls, Ohio 44022



present three sizes of Sportsters. My .45 Sportster had almost 50 flights (4-ounce tank and 8- to 9-minute flights) when a radio failure buried it long before the 15 hours. My .20 Sportster is running about 20 minutes per flight on a 4-ounce tank and loafs along in an old timer turning a 12-6 Master Airscrew with unbelievable quietness running from 5800 rpm down to 1400 rpm at idle.

After this month's .65 was carefully broken-in and rpm readings were recorded, the engine, with a six-ounce fuel tank, made seven fun-filled flights with all the test sizes of props and also with a new four-blader. It was pure fun until a radio failure rekkited it. At crash time, the .64 had a Bru-Line air filter in place; dirt didn't enter the

engine. Total damage was a mangled spraybar; pull out the old one and press in a new one. Easy. The crankshafts are precision-ground to a chrome-like finish on all three working surfaces. The .65's crankshaft weighs a husky four ounces, and the replaceable 1/4-28 front prop stud is again used. The crankshaft's main bearing is 1.750 inches long and the .650-inch diameter shaft runs in a full length oil bath; a bit tighter than the .20 and .45. Air/fuel passageway down the hollow shaft is .400-inch diameter, and the shaft's intake window measures .725 inch front-to-back, .350 inch wide, and is slightly bathtub-shaped; no sharp corners for stress concentration. A single flat on the shaft engages the cast prop driver. A thin hardened blued steel washer

# Why buy an imitation when you can have the real thing?

Zap adhesives are the most imitated products in the hobby industry. Yet nobody has managed to duplicate Zap quality. Doesn't that tell you something?

# ZAP

"THE TOTAL ADHESIVE SYSTEM"™  
The Real McCoy.

  
House of Balas  
20130 State Road  
Cerritos, California 90701  
(213) 880-1276

Regional Sales Offices:  
  
310 North 5th Street  
St. Charles, Illinois 60174  
(312) 584-7616

  
Frank Tiano Enterprises  
2460 SW 85th Terrace  
Davie, Florida 33324  
(305) 473-2211

Manufactured by Pacer Technology, 1600 Dell Avenue, Campbell CA 95008 ZAP is a registered trademark of Pacer Technology

## WARBIRD CHECK-OUT VIDEOS

### WARBIRD CHECK OUTS—Vol. I

"Flying The P-40 Warhawk" **COLOR!**  
The WW II Curtiss-Wright fighter, made famous by the Flying Tigers  
"Flying The F4U Corsair"  
Check out the familiar "dell" wing wartime fighter.  
"Flying The F6F Hellcat"  
Stalls, dives, landings and takeoffs are just a part of this flying experience  
"Flying The SB2A-4 Buccaneer"  
The Buccaneer found its place in wartime activities as a scout plane.  
"Flying the TBF Avenger"  
Air-to-air photography demonstrating combat techniques  
NF132 — 4 Complete Programs, 2 Hrs. ....Only \$39<sup>95</sup>

### WARBIRD CHECK OUTS—Vol. II

"Flying The Twin Engine P-38"  
Get the job of escorting U.S. bombers over enemy territory in broad daylight  
"Flying The B-25 Mitchell Bomber"  
Chosen by Jimmy Doolittle for the famous Tokyo raid  
"Flying The Twin Boom P-61"  
The "Black Widow" sought out invisible targets with sophisticated radar.  
"Flying The Twin Engine A-26"  
Pilot's "hot ship".... flying adequately on just one of its R-2600 engines  
NF145 — 4 Complete Programs, 100 Min. ....Only \$39<sup>95</sup>

### WARBIRD CHECK OUTS—Vol. III

"Flying The P-51 Mustang"  
The most important fighter in the 8th Fighter Command in England. It was designed, built and flown in 117 days.  
"Flying The A-20 Bomber"  
The most famous in a long line of conventional light attack bomber aircraft.  
"Flying The P-39: Introduction"  
Some 9500 were built. An unusual design with engine located mid-fuselage and nosewheel type landing gear.  
"Flying the P-39: Advanced"  
The P-39 Airacobra in high speed flight maneuvers and combat  
NF-151 — 4 Complete Programs, 110 Min. ....Only \$39<sup>95</sup>

**SPECIAL INTRODUCTORY OFFER!**  
Any 2 Vols. \$75<sup>95</sup>, All 3 Vols. \$107<sup>95</sup>  
CALL TOLL FREE

**1-800-525-6563**

IN CA (213) 827-8666  
Shipping Prod. In U.S. & Canada. Foreign Orders Add \$5.00  
SPECIFY BETA OR VHS California Res. Add 9% Sales Tax  
ALL MAJOR CREDIT CARDS  
Include Mo. & Exp. Date

Send to: NFV, 13470 Washington Blvd., Ste. 308, Marina del Rey, CA 90292

## VINTAGE R-C PLANS



CONSOLIDATED  
PB-5A "CATALINA"

9 FT. WING SPAN  
ALL RIBS & FULL FORMERS SHOWN ON PLANS !!  
PLASTIC ENG. COWLS \$10.90 PR.  
CLEAR GUN BLISTERS \$7.60 PR.

4 LARGE PLAN SHEETS — Plans \$18.95  
6 FT. WING SPAN MODEL PB-5A  
ENGINE COWLS \$7.50 PR. Plans \$14.95  
GUN BLISTERS \$5.50 PR. ADD \$3.00 POSTAGE

CATALOG—OVER 50 PLANS \$1.00 DEALERS WRITE

WORLD  WIDE  
SID MORGAN

13157 ORMOND, BELLEVILLE, MICH. 48111 U.S.A.

behind the prop driver takes the rearward pressing load of the electric starter if used so the prop drive washer won't rub directly

## FAI RUBBER

SIZES: 1/4", 3/16", 1/8", 3/32", 1/16"  
.042 thick one pound box.

Price: \$13.95 no lube (Slick costs \$1.75)  
Price: \$14.95 includes 4 oz. Slick Lube.  
Postpaid in US via UPS Ca. add 6% tax.

100 FF kits inc. Coupe Deville, Starduster, H.L. Gliders, Pee Wee 30, Potent 30 & more. Satellites, 3 Pearls, Pacifiers, KSB, Seelig timers, Tilka, Open rubber, front ends, Fuse, 3 prop kits, Winders, Books, much hardware.

1988/89 CATALOG \$1.50

 **F.A.I. Model Supply**  
P.O. BOX 3957 TORRANCE, CA 90510

on the nose of the case casting. Simple and inexpensive.

Low speed idle performance is a major

criterion for an R/C engine. The .65 came with a K&B non-idle bar plug which I used for muffler-off break-in. All testing was done with their #4520 idle bar plug, which contributes well to idle performance. Also, the crankshaft's four ounces is concentrated in the .45-inch front-to-back massive thickness of the crank's disc, which contributes well to idle performance. Indy R/C's new A.S.P. also has an unusually thick and heavy disc.

Unless an engine has been factory-run, as Fox does, the rear crankcase cover and glow plug should be removed *before the engine is even turned over*. It should be flushed out with a solvent/cleaner, like 70-percent isopropyl alcohol which is about 50 cents a pint and is safe to handle (pharmacy product), to swish out any unwanted small metal chips before running. When replacing the hardened socket head Allen bolts of the rear cover, tighten only to match the original tightness. The Allen bolts can cut threads in the alloy just like a new sharp tap, and overtightening will strip the bolt holes. Use care. The model I flew the .45 in was heavy, and removing the muffler's baffle assembly yielded more useable rpm. This .65 Sportster has plenty of "get up and go" for a normal to heavy full-size Ugly Stik and many other similar size/weight sport models. It's far more quiet than an equivalent rpm four-cycle engine, and using the bigger diameter props further lessens any annoyance factor.

This is *not* an engine for the high-performance .60-size pattern model, nor does it cost like the engines suitable for that type of model. It's designed for the fun-seeking sport flier and has the world's best guarantee matched to the world's best muffler system. It comes complete with an extra cast-metal "spider-like" combination rear backplate and engine mount for firewall use. It starts easily by hand, very comfortably swings and flies several different prop sizes, and I never had reason to turn the needle valve a *single click* during the two flying sessions. When you study the performance chart below, consider the cost of the .65 Sportster as compared to today's imported four-stroke cycle engines; think of the low piece count in this engine compared to the four cycle's complexity. The K&B .65 Sportster is a likely alternative to a four-cycle at about a quarter of the cost, half the parts, and about three-quarters the weight per thousand rpm.

Bobby Tom at K & B told me he'd like to see the engine scaled up to a .90-size or so. At the '88 Nationals the Sportster designer, Bill Wisniewski, told me they were talking about both a .90 and a 1.20 size! Success breeds success.

### MEASURED PERFORMANCE

Readings are after break-in and with black Master Air Screw props. 10-percent Red Max fuel is used with one ounce of castor oil added to the gallon. The supplied muffler is used except as noted. The K & B #4520 idle bar plug was installed.

Prop Size	Low Speed	High Speed	Speed Range
11-6	2,050	11,950	5.83:1
*11-7	1,950	11,550	5.92:1
11-7 1/2	1,950	11,300	5.79:1
12-6	1,900	10,850	5.71:1

# Flight School.



©1988 Futaba Corp.

## It's elementary with the Professor.

Go to school with the Professor, the radio control trainer that makes electric flying easier than ever. Extremely stable design and

is as close as the schoolyard. Let Futaba and the Professor show you how simple it can be.

Advanced, lightweight materials are used for the fuselage for exceptional strength and rigidity. And built-up, pre-covered wing, tail and stabilizer eliminate the need for special assembly skills. Simply join the wing halves, attach stabilizer, tail and pre-installed linkages. Mount the propeller to the gearbox of the powerful Mabuchi RS540SH motor, install radio and batteries and you're ready for takeoff.



### PROFESSOR SPECIFICATIONS

Length	35.04" (890mm)
Wingspan	48.82" (1240mm)
Area	446.5 sq. in.
Weight (w/rec. system)	39 oz.
Motor	RS540SH w/3:1 reduction gearbox
Recommended system	Futaba 4NBL/MCR

**REQUIRES:** 7.2v/1200mAh NiCd battery pack and charger, 2-4 Channel radio control system (electronic speed control optional).

*Futaba MCR-4A Integrated MOSFET speed control/receiver (Not included) required for optimum performance. Specifications: 4 Channel; 1.5 oz. (excluding switch and connectors); 1.24" x 2.92" x 0.63" BEC Voltage regulator.*

*Electrifying fun for the more advanced pilot. Aerobatic Hirobo/Futaba Chipmunk (Available soon).*



*The complete Professor kit comes out of the box ready to assemble.*

ARF assembly are just a few of the features that make the Professor ideal for novice flyers.

Clean, quiet flying excitement

## Futaba.

Futaba Corporation of America  
555 West Victoria Street Compton, CA 90220



# QUARTER-SCALE CAP 10B



"The CAP 10B is the only CAP I have ever flown that showed absolutely no tendencies to stall a wing on landing no matter how slow I flew it! It is extremely docile to land but is capable of full aerobatics including Lomcevaks. It is a pleasure to fly."—Ronnie Kemp

**\$260.00**

Wing area: 980 sq. in.  
Wingspan: 75 in.  
Length: 62 in.  
Weight: 13-16 lbs.  
Wing Load: 35 oz/sq. ft.

Kit includes: fiberglass fuselage with formers installed, fiberglass rudder and wheel pants, balsa-sheathed foam core wings and stab, pre-cut landing gear blocks, and vacuum-formed canopy.



**Yellow Aircraft & Hobby Supplies Ltd.**

11918 98th Ave. E., Puyallup, Washington 98373 (206) 845-8195

\*\*13-6 1,900 8,950 4.71:1  
\*\*\*14-6 1,500 8,400 5.42:1

\*With muffler removed, the 11-7 peaked at 13,150 rpm.

\*\*With glow plug battery left "on" the 13-6 idled reliably at 1500 rpm.

\*\*\*With glow plug battery left "on" the 14-6 idled reliably at 1200 rpm (an amazing 7:1 speed range).

A speed range below 4:1 is unsatisfactory.  
A speed range of 4:1 is barely satisfactory.  
A speed range of 5:1 is average.  
A speed range of 6:1 is excellent.  
A speed range above 6:1 is superb performance.

The K & B .65 R/C Sportster #5800 is

## Tubing Tools



Cutter handles round brass, copper or aluminum tubing in sizes up to 5/8 O.D. A specially designed nylon body reduces grip friction to make cutting easier. Cuts without crimping, too. Tubing benders handles tubes up to 3/16 O.D. V-block clamp holds securely for cutting, drilling, filing, etc. Send 25 cents for our price list and tubing, shapes, wire and tool catalog. K & S Engineering, 6917 W. 59th St., Chicago, Illinois 60638. Telephone: 312/586-8503.

**K&S** FULL LINE METAL SPECIALISTS

made by K & B Manufacturing, Inc., 12152 South Woodruff Avenue, Downey, California 90241. The factory operates Monday through Thursday. The retail price of this engine at time of testing was \$99.95. •

**Technical . . . . Continued from page 34**

Actually, the calculation of wing bending stress and spar design is an easy thing to do theoretically, but in most cases we model designers don't bother. We just put in a spar that "ought to be plenty strong enough," like we "design" the rest of the model. In commercial full-scale airplanes, the wing spars are truly engineered, as are a great many other high-stress components, but even in full-scale, much of the airplane is just drawn and built. To stress analyze and engineer every little part for minimum weight would be prohibitively expensive, but it would make possible significant airplane weight reduction. I'm certainly not going to propose extensive detail engineering of our model structures, but I am going to propose that we do some thinking about the strength needs in various parts of our models, and a lot more thinking about the most effective ways of achieving these needs.

Last month the subject was weight, and weight will surely be a major factor in our search for these most effective structures. Strength-to-weight ratio is not the only factor to be considered, however. Other considerations are simplicity, reliability, low cost, ease of construction, appearance, long life, safety, etc. It ain't simple. That is one of the reasons why design is such a fascinating challenge. It is also the reason why no two model designs are alike. Each designer puts a different value on each of the many factors to be considered, and therefore ends up with a different airplane. Even deciding which of those many designs is best isn't easy; every judge has a different racing system, mostly subconscious.

Weight, however, is a major concern on my weighting scale (do I need to explain that?), so you are hearing about weight whether you like it or not. There is a saying, "If a part never breaks, you probably built it too heavy." I also like the motto, "Simplicate and add lightness." Simple means fewer parts, less cost, less labor, more reliable, and probably less weight.

### CRASH LOADS

In full-scale planes, flight loads and landing loads are about all the loads the designer has to worry about, but in models we have to add handling loads and, to an extent, crash loads. Yes, full-scale flying machines crash too, but to design them to survive crashes would be next to impossible. Anyway, the survival of the crew and passengers takes precedent. Model airplanes, however, can, at least partially, be designed crash-resistant. Our models do crash occasionally, or haven't you noticed? Where I can design to reduce the probable repair time after a crash, at the cost of only a few percent in model weight, I consider it a bargain.

Interestingly enough, designing for crash resistance doesn't necessarily mean designing it stronger. In fact, in some cases it is

# Dreamgirl.

With her stunning looks and sparkling performance, who could blame you for guessing that the Sophisticated Lady might be a bit of a snob?

Fact is, she isn't.

She's a high-flying beauty with a personality that couldn't be more down-to-earth.

## SOPHISTICATION. NOT COMPLICATION.



All the tricks are in the engineering—not in the skills you'll need to build her. The Lady's designed to go together straight and true, with the help of plans and instructions that may be the most complete you've ever seen. There's even a section on techniques for the various forms of soaring.

So if you aren't an experienced

builder, don't let her graceful lines and state-of-the-art T-tail scare you. Building the Lady is a piece of cake.

## THE LADY LOVES A CHALLENGE.

Even if you put her up in weak air, her extraordinary L/D will reward you with impressive durations.

In more active conditions, add a bit of ballast and the Lady's slim airfoil and slender contours let her knife through turbulence and handle booming lift with ease.

And while she's built to shrug off the rigors of standard 2-meter high-



*The C.G. Electric Power Pod (No. 678), is perfect for the Sophisticated Lady, the Gentle Lady and lots of other 2-meter gliders.*

starts and lift-grabbing tight turns, she won't be insulted if you prefer the more relaxed fun of powered climbs with the C.G. Electric Power Pod.

Whatever your pleasure, the Sophisticated Lady is great company.

## SHE'S GOT ALL THE ESSENTIALS AND SOME EXTRAS, TOO.

As you might expect, the Lady's kit is complete in every detail. The wood is select, the cutting is precise, the hardware is like fine jewelry, and there are nice touches—like her formed canopy and cockpit detail—just to sweeten the deal.

And speaking of the deal, you don't have to be a big spender to take her out, either.

So don't keep the Lady waiting. She's at your local dealer's now, and we hear she's just dying to meet you.

**CARL GOLDBERG  
MODELS INC.**

### THE SOPHISTICATED LADY (KIT 59)

SPAN: 78 1/2"  
LENGTH: 43"  
WING AREA: 663 SQ."  
WEIGHT: 25-29 OZ.  
RADIO: 2 CHANNEL (MIN.)

The Sophisticated Lady.™  
A 2-meter thriller from Carl Goldberg Models.

**All Paper Flying Scale Model Airplane \$7.00**

14" Wingspan

Includes POWER KIT

\*ALL PARTS PRE-CUT & PRE-PAINTED  
\*BUILD & FLY IN TWO HOURS

PAPER AIRPLANES  
1521 MORNINGSIDE DRIVE  
BURBANK, CALIF. 91506

CATALOG: \$7.50 Contains 1000's of paper airplanes. From postage stamp size to 6 foot wing span! Gliders or rubber powered. Die-cut or you-cut. Largest known source of paper airplanes in the world! Cost of catalog deducted from 1st order over \$25.00. ASTOUNDING! Catalog and CORSAIR paper airplane above: \$10.50 plus \$2.50 postage.

**Wilshire Model Center**

Sailplane & Electric Catalog! \$2.50 ea.

Imported and Domestic Sailplane Specialists, R/C Supplies, Geist Electric Flight, Multiplex Radio

Mon.-Fri.: 10-8 Wilshire Model Center  
Sat.: 10-6 2836 Santa Monica Blvd.  
Sun.: Flying! Santa Monica, CA 90404  
Owner: Bob Ratzlaff 213/828-9362  
We gladly accept Visa & MC on orders over \$10.

**The Only Way to Fly**  
Fabtronics Mark 3 C.D.I. pointless system



Works Great for Most  
2 and 4 Cycle engines  
Automatic Spark Control now available  
for most 4 cycle engines.

Complete System (Less Batteries) ..... \$69.95  
(add \$3 post. & Hand.)

**FABTRONICS**  
375 Isle Royale Rd., Galesburg, IL 61401

**ELECTRIC SUPPLIES**

You've tried the rest...  
Now buy the Best!

**AIRCRAFT SPEED CONTROLS**  
SC-5 02 to 05, 2 to 8 cell \$62  
SC-4 05 to 40.7 to 26 cell \$62  
SC-3 25 to 200.8 to 30 cell \$127

**WIRE & CONNECTORS**  
#16 WIRE - 259 STRAND \$7  
#12 WIRE - 665 STRAND! \$7

**SERMOS CONNECTORS - 4 poles \$3**

and accepted  
JOMAR, 2028 Knightsbridge Dr.  
Cinti., OH 45244 / 513-474-0985

quite the opposite. This anomaly comes about because to add strength we usually add weight. Weight is one of the factors in kinetic energy, and the kinetic energy in a crash is what re-kits the model. Another way to reduce or eliminate crash damage is to make parts of the model more resilient so they will absorb part of the impact energy. Sometimes we can make a rigid part resilient by subtracting weight instead of adding it. That is a double gain! One can compare rubber-powered to R/C models, on the subject of crash resistance. I don't have real data, but I suspect the flight-to-crash-damage ratio for ultra-light indoor models is as good or better than it is for R/C models. The strength of the indoor is almost negli-

ble, but so is its weight and so is its flying speed. As weak as it is, it seldom has enough kinetic energy in a crash to injure itself.

Back in 1970, I had a bright idea to reduce or eliminate crash damage in R/C models. The outcome is shown in the photo of the twin-boom pusher with the probe sticking out in front. The secret is hidden in the probe. It is really a shock absorber. I reasoned that most crash damage comes from nose dives, so I somehow needed to absorb the head-on kinetic energy in a crash. Another approach would have been to install some kind of spring bumper on the nose, but this would store the crash energy and cause the plane to bounce back in the air like a pogo stick. A bouncing airplane didn't sound appealing. The probe on this airplane, therefore, did not store and re-release the energy, but absorbed it and turned it into heat by means of a linear brake built into the probe. The probe was an aluminum tube that telescoped into a slightly larger fixed aluminum tube which was built into the fuselage. I designed and built a sliding cone-collet-type shoe brake on the rear end of the probe tube, which bore against the inside of the fixed tube. The constant braking force throughout the 18-inch travel of the probe was adjustable from zero to 300 pounds or so. The six-pound airplane also had its one-pound wing panels designed to pop off in a crash, so the net crash energy was that of a five-pound plane.

Looking at the arithmetic here, if I set the brake for 250 pounds, that figure times the

1.5-foot travel gives a maximum of 375-foot pounds of kinetic energy which the device could absorb. Solving the kinetic energy formula for velocity, with  $K.E.=375$ , and  $W=5$ , the speed could be up to 48 mph, and the plane would completely stop before it ran out of probe travel.

So far so good, but there was another factor I had to consider: deceleration on impact. Could I stop the flying model in 18 inches without damaging it? In this case it turns out that the deceleration on impact would be 50 g's. That is not bad. I think most of our R/C models could withstand 50 g's front-to-back deceleration without damage. Actually, in a crash into a concrete wall, the front of a model stops in almost zero travel and therefore experiences probably thousands of g's. The tail of the model stops in the fuselage length or less and may experience quite moderate g's. That is one of the reasons why empennages are seldom injured much in crashes. They have shock-absorbing fuselages in front of them. The more travel we can allow the model in decelerating, the lower the impact g's will be, and the less damage it will sustain. That is obvious. We all know that concrete is worse than soft ground, and a bad landing in tall grass usually results in little or no damage.

Back to the photo. Did the idea work? Somewhat, but it found another crash-damage mode. In the only crash I had with the model, the probe retracted about half way and then bent sideways. I thought I had chosen a strong enough tube to withstand any likely side loads, but I guessed wrong. In theory it was a good idea, but like many good theories, it didn't work out well in practice. For one thing, it complicated rather than "simplified" the model. I long ago learned that most of my bright ideas aren't going to work, but I keep trying because innovation is a lot of fun. I also observe that the failures are valuable because we learn a lot from them. If a bright idea works, we don't learn much because we already knew how. The best way to acquire knowledge in modeling is to try many things and make many mistakes. We tend to forget the good advice we read, but a crashed airplane is a much more effective and permanent lesson.

#### WING MOUNTING

One area where we can reduce crash damage to our models easily, and with little or no added weight, is in the design of the wing mount. We can do much better than most of the bolt-on R/C wing mounts. Interesting enough, the old rubber band wing mounting system isn't half bad, which is doubtless one of the reasons why it is still used a lot. In a crash, the rubber bands stretch, storing energy, and reducing the severity of the impact. As I pointed out above, storing the energy isn't as good as dissipating it, but it is a lot better than letting all of the energy crunch balsa.

The wing should be resiliently mounted or mounted to separate from the fuselage in a crash because if it is rigidly and strongly mounted, additional damaging loads will be imposed on both the wing and on the fuselage. Let's examine how. First, the case of a crash where a wing tip strikes first. This will cause the wing to try to pivot on the



# The Right Choice

## Simply the Best Values in R/C.

For quality, styling, and exceptional value, the Hobbico line of R/C products can't be beat. Whatever the application, we'll meet your own high personal standards with our fast-growing line of hobby equipment and accessories. Each product is specially-designed for top performance and is backed up with warranty and service like no other line of hobby products. When you want quality and reliability at a price that's always pleasing to your pocketbook, choose Hobbico R/C products. See them at your favorite hobby dealer today.



AC/DC MULTI-CHARGER



DELUXE POWER PANEL



DELUXE 12V STARTER



MULTI-CHARGER



QUICKSAND



6-MINUTE EPOXY



EXPANDED SCALE VOLTMETER



DIGITAL MINI-TACH



HAND-CRANK FUEL PUMP

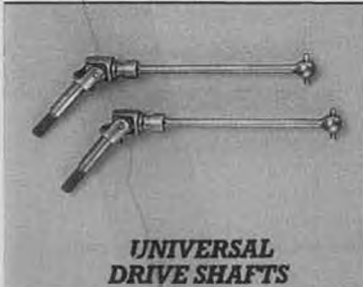

UNIVERSAL DRIVE SHAFTS



MAFREC SEALED BATTERY



LOCKING GLOW PLUG CLIP



12 VOLT BATTERY



BUGGY BOX (Pre-Built)  
DELUXE FIELD BOX

Folding Legs: Optional

DISTRIBUTED BY:  
**GREAT PLANES**<sup>TM</sup>  
MODEL DISTRIBUTORS COMPANY  
P.O. BOX 4021  
CHAMPAIGN, IL 61820

Send for your 44 page, full-color Great Planes Exclusive Products Catalog today! Only \$2.00 for all of the best in R/C!

© 1988, Hobbico, Inc.



# GNOME

The "Hi-Performance Compact"  
RADIO CONTROL SAILPLANE

60" Wing Span  
375" Wing Area  
12 to 15oz. / 2ch R/C

Optimized Eppler 205 Airfoil

Hand Launch •• Slope •• High Start / Winch

**\$34.95**

**THE MIDWAY MODEL COMPANY**

P.O. Box 19 MIDWAY CITY, CA 92655 (714) 895-6589

At your Dealer or  
add \$2.00 per order  
for UPS. Ca. Res.  
add 6% for Tax.





**The 'super' systems  
Maneuver, mix, adjust,  
reverse and monitor.  
We introduced expo rates!  
Three, six and eight channels  
"STILL THE BEST!"  
MILLCOTT  
Millcott Corporation  
177-F Riverside Ave. Newport Beach CA 92663**

**(714) 642-3799**

fuselage, putting destructive wrenching loads on both the fuselage and on the wing center section. If the wing is mounted so it can somewhat freely pivot on the fuselage, these wrenching loads will be largely absent. Not only will the fuselage and the wing center section both be completely or largely saved, but the wing tip which struck the ground (or a tree, etc.) will also suffer much less damage because the impact load placed on it in this case is due to the inertia of the wing alone and does not include the inertia of the rest of the plane, as in the rigid-mounted case.

When a plane with a rigid-mounted wing strikes nose first, all of the kinetic energy of the plane, including that of the wing but excepting the engine, is concentrated in crunching the forward part of the fuselage. (Note: In a pusher configuration the inertia of the engine would be included in fuselage crunching, but the chance of damage to the engine itself would be decreased.) If we mount the wing so it will detach in a crash, we subtract the inertia of the wing in figuring our fuselage-crunching load. We also reduce the chance of damage to the wing.

In many R/C designs, the wing is mounted with nylon screws. Doubtless the designers chose nylon instead of steel because the screws are supposed to shear off in a crash and release the wing, as I too am advocating. The intent is fine, but the implementation is often flawed. Most of the nylon screws used are too large for the job. Check

your past crashes. How many times did the nylon screws stay in one piece, but the wing mount partially or totally ripped out of the fuselage or the wing? You were using too large a "fuse." Never use 1/4-inch nylon screws in anything smaller than a Quadra-powered model. #10 or even #8 nylon screws are plenty strong enough to hold the wing on a sixty-powered, and they have more of a chance of shearing in a crash.

Another common practice in mounting wings, which I disapprove of, is the butting of the leading edge of the wing against a fuselage bulkhead, and locating it with dowel pins. Sure it's a neat method, but not so neat in a crash, unless you love to repair airplanes. How is a wing so mounted going to be able to come forward without taking out the bulkhead or its own leading edge? You haven't heard the last of wing mounting from me, but this is enough for now.

Until next month, it is never too late to have a happy childhood; design your own toys.

**Electric. . . . . Continued from page 19**

rubber bands, and you are done!

John Foley sent a photo of his modification of a Craftaire digital voltmeter/tachometer. He epoxied a pair of test lead plugs to the case, drilled two small holes from the back, and ran the black and white wires through the holes and to the plugs. He finds this setup is quite handy as a monitor for

charge voltage. The Craftaire voltmeter/tachometer is reasonably priced at \$60 and is available from hobby stores or Hobby Barn, P.O. Box 17856, Tucson, Arizona 87531; (602)747-3633. John loves to design his own planes and sent a bunch of photos. The SE5A is from *Model Airplane News* plans and uses a geared Astro 25 cobalt at 6.25 pounds. John has not done any flying with it yet. It looks good to me, but I would use a 40 for a plane in that weight range.

John's Ultra Mk IV is a very good flier with a Mabuchi 550 and a Carrera 3.28:2 gear drive. The prop is a cut down three-bladed Robbe folding prop. The Ultra is available as plans from *Model Builder* and is one of the very best electric gliders I have seen perform. John's Slow Motion, designed by Bill Evans, uses an Astro cobalt 25 direct drive on fourteen 1200 mAh cells and is a wild plane in the air! I have a Slow Motion in progress, but right now all my work is in slow motion, so I don't know when it will get finished. Several readers have said this is a good one for electric, and power has ranged from a geared cobalt 05 to the 25. It is available from Bill Evans Aircraft, 454 Wildrose Lane, Bishop, California 93514; (619)873-4932. Thanks, John, for the info!

John Mountjoy sent a photo of his Cessna AW built from W.E. Tech plans. The photo is in color; the plane is bright red. I had not realized the Cessna AW could be good-looking, but from this angle it is very attractive. It looks like a racer, which makes sense since that is how Clyde Cessna first became famous. The covering is Permagloss Coverite; it weighs 8.8 pounds and uses the sport wind Astro cobalt 60. There are 21 sub-C cells and it is four-channel. Wing area is 900 square inches, 1/6 scale. At the time of the photo, John had not flown it yet, but I think it will fly very well. The W.E.T. plans are done by Bill Effinger, who is the designer of the Berkeley Brigadier, one of my favorite planes. Send a dollar to W.E.T. at P.O. Box 76884-A, Atlanta, Georgia 30328, for a brochure showing the plan sets for 1988. I'm sure you will find one to your liking!

A reminder: the Dallas Electric Aircraft Flyers will have its second annual fun-fly on Saturday, October 1. It will be at Eastfield College off I-30 and Bigtown Blvd. from 8:30 to 5:00. Contact Frank Korman, 5834 Goodwin, Dallas, Texas 75206, (214)821-0393, after 5:00 p.m. for information.

Well, enough for now. Till next time, remember the most important equation: electrics equal more fun!

**Hey Kid. . . . . Continued from page 47**

all attempts to get it right are adding a little weight to a wingtip to get the model to settle into a glide turn, and adding a drag tab (a 1/4-inch tall piece of 1/16-inch balsa sheet about 1-1/2 inches long glued to hang straight down from the trailing edge about 3/4 of the way out of one wing). That will drag that wing to the rear and also force a little air downwards to keep that wing from dropping too much in the turn.

Remember to make only one adjustment at a time so that you will know what effect it

has. Also check occasionally to see that no warps have crept into your wings or tail due to the effects of sunshine or damp weather. For a beginner, warped wings and tail surfaces can be like a ball player starting with two strikes before he comes to the plate.

When you are done flying, remove your motor, wash it and dry it, and shake it in a baggie with a little talcum powder. Stretch it a little at a time while closely inspecting it to see if there are any nicks or tears. You should cut it and retie it at any weak spots (or chuck it out). A good rubber motor should be respected and never wound to full winds if you want to keep it awhile. Winding a motor while stretched up to half turns and then letting it rest awhile and then going to 70 percent, etc. in stages will help the motor last. This is known as "breaking-in" and helps the molecules in the rubber arrange themselves for the job you are going to have them do. Try winding a new motor to maximum turns about four times, maybe without lubricating it, and then take a close look at it. You will see what I mean. It will not fly your plane too well after that, and will break early. Some brands of rubber are good for one flight, after that they have lost half their power at the same number of turns! You will notice that after a full-winds flight, your motor will take about 20 minutes to recuperate to full power. Keep it out of the sunlight, and dirt too.

Storing your motors in those little black plastic snap containers that 35mm film comes in helps them last longer and can be labeled with a piece of masking tape as to rubber size and which model it goes to, with a star for the one that worked best!

#### KEYING THE WING

If you found that it was a drag getting the wing back on exactly in the right alignment after each hard landing, you might want to cut four wing "keys" from split 1/8 round hardwood dowel and glue them on the wing right up against the sides of the fuselage. Glue them flat side down to the L.E. and T.E., not to tissue paper which will just tear. They will guide the wing back to the correct position every time. Rounding the part that touches the fuselage helps the key ride up over the part it butts against without taking a gouge out of it in a crash.

#### ADDRESSES

Flying Aces Moth kits, winders, rubber, etc.: Peck-Polymers/Beginners, P.O. Box 2498, La Mesa, California 92041. Catalog \$2 or SASE for sheet of materials used in this series.

Propeller blanks and other supplies can be obtained from Old Timer Model Supply, P.O. Box 7334, Van Nuys, California 91409. Catalog \$2.

**Counter. . . . . Continued from page 9**

manual that makes building fun and easy. Wings are built on hardwood spars with a fully sheeted D-tube leading edge. The box fuselage is made of micro-lite plywood and balsa with triangle stock reinforcements. The .20 size has a 47-1/2-inch span; the .40, a 52-1/4 span; the .60, a 60-inch wingspan. Aerobatics are easily performed with any of these models. For more information, con-



## For a real blast... FLY A-J!

- ★ "404" Interceptor (RTF)..... \$6.95
- ★ A-J Hornet (RTF)..... 6.95
- ★ "74" Fighter (3-PAK)..... 6.95
- ★ A-J T-Shirts (ALL SIZES)..... 7.95

Note: Please add \$3.00 for Postage and Handling on first 3 packaged models. Add 10% of price for each additional model.

**American Junior™**  
**AIRCRAFT COMPANY**  
P.O. Box 68132  
PORTLAND, OR 97268  
(503) 653-2038

tact Midwest Products, 400 S. Indiana St., Hobart, Indiana 46342.

\* \* \*

Hobbico recently introduced two new glues for modeling applications, a 6-Minute Epoxy that dries hard, but not brittle, and remains fuel-proof with age. It is sandable and comes in two 4-1/2-ounce bottles. Also, Hobbico Quicksand is a white aliphatic glue that is extremely sandable, making it perfect for use with micro balloons. It dries strong and clear in 20 minutes. The 6-Minute Epoxy and Quicksand are available at Great Planes Model dealers nationwide.

\* \* \*

Balsarite, that old favorite from Coverite, is now available in two formulas. The original is still produced for use with fabric coverings and Coverite's Micafilm. Now there is a brand new formula designed for iron-on film such as Black Baron, Mono-Kote, Solarfilm, and other coverings. Balsarite can even be brushed over fuel-soaked wood so that it can be recovered. Look for the new green and white striped can; the old formula is still available in the all-green can. You won't be sorry! Coverite, 420 Babylon Rd., Horsham, Pennsylvania 19044.

**Free Flight. . . Continued from page 59**

*square inch airplane looks about like 'that.' You know? And I get my three flights in right away, and then if the guy is gonna beat me in the afternoon, if any wind comes up, he can't beat me. It's out of sight, if they're in a thermal, it's out of sight. You know, you*

## Fox 19BB Schneurle



#### SPECIFICATIONS

BORE	650
STROKE	600
DISPLACEMENT	199
WEIGHT	8 oz
RPM with 8-4 prop	17,000
FUEL CONSUMPTION	4 oz /min.

Recent Fox design gives this engine the performance punch that the most exotic racing motors have. But, this engine is docile in nature and has a hot restart capability that is lacking in many A B C motors.

Order#	Style	Cost
12000	Fox 19BB C.L	\$59.95
22000	Fox 19BB F.C (w/muffler)	\$79.95

## Fox 25



#### SPECIFICATIONS

BORE	680
STROKE	680
DISPLACEMENT	25
RPM with 9-4 prop	12,000
WEIGHT	6 oz
FUEL CONSUMPTION	4 oz /min.

#### Light, Powerful, and Big

This 25 is as light as most 19s, but packs more power than some 29s. A superb performer, the Fox 25 has been on the market long enough to be thoroughly tried and tested. It's American made and features an MKX-type carburetor.

Order#	Style	Cost
12500	Fox 25 Bushing C.L	\$49.95
22500	Fox 25 Bushing F.C (w/muffler)	\$69.95



**FOX MANUFACTURING CO.**  
5305 Towson Avenue  
Fort Smith, Arkansas 72901  
(501) 646-1656

# Don't Be Hornswoggled!

The pushrods of your aircraft can be considered it's very lifelines. You can't entrust their operation to just any control horns. The all new Robert Ball Link Control Horns give you the precise control you're after without the need to bend and kink your pushrods no matter what the application. With the rotating ball link located with the horn body, the Robert horn offers more accurate, on-center control and it eliminates the need for an additional ball link on the end of your pushrod. Why waste your money on a more expensive, less efficient control system, when you can save time and money with Robert Ball Link Control Horns?

**robert**

AT YOUR FAVORITE HOBBY SUPPLIER



© Robert Mfg. 1988

P.O. Box 1247 St. Charles, Illinois 60174

## B&P ASSOCIATES PRESENTS THE FINEST



**STARTER BATTERIES.**  
12 Volts 4.0 Amp. hour  
B&P ASSOCIATES with more than 25 years Experience in the Design, Manufacturing, and Assembling of Nickel Cadmium cells and batteries, now presents the FINEST STARTER BATTERY FOR YOUR STARTER, with Charger. Just Charge It once, and

it will last the weekend for Starting your Plane. Also 2.0 and 7.0 Amp. Hr.

B&P ASSOCIATES P.O. Box 22054  
Waco, TX 76702-2054 (817)662-5507

For your battery needs, Call or write:

*gotta stay in sight. If you have an hour flight and you can only see it for 10 minutes, what the hell good is it? So, I fly early.*

JT: Let me come back to something we talked about earlier: when do you decide to launch downwind?

ST: Only when it's windy. When it's very, very windy. High wind. And if the airplane will perform like that. Now, the Starduster 600 can be launched downwind, but the 1/2A Stardusters I launch into the wind, even in a gale. And the Orbiteer I should have launched downwind today. I'd have been much better off. But I am second-guessing myself now.

It's a live and learn thing, you know.

You're always learning in modeling. Every time you launch you learn something new that helps you win the next time. A kid asked me one time how do you win contests? I said, Well, you make a mistake, you remember it, and you don't make that mistake again. Of course, the airplane is just a machine; it's doing what you tell it. If you eliminated your short engine runs, you eliminate your short fuses, you eliminate your lousy timers or your lousy running engines, if you get everything together, then the airplane will perform, and eventually it will win for you.

But you can't go to a contest with an engine that's runny ratty because you're never

gonna win. Or with a bad timer that's erratic; that's running 12 seconds one time and 6 seconds the next. You gotta eliminate all of these things that will cause a variation in flight. Now, when you eliminate all the variables, and you have everything going for you, you start winning. Of course, the airplane, like I say, is just a machine. You tweak the rudder, it turns; if you don't tweak the rudder, it goes straight. If you give it a little negative incidence, it glides a little better. If you give it too much, it stalls. These things you learn; you put them all together, and eventually you start winning.

It's that simple. Every time you make a mistake, you remember it, and you don't make that same mistake again. That's all. In life, in any kind of sport that you're into—same thing.

### THE RUBBER STORY—VERSE TWO

Well, just after joining a number of other columnists and newsletter editors announcing and decrying the demise of the domestic rubber supply, along comes a phone call from Ed Dolby, proprietor of FAI Model Supply. Ed called me to correct the statement. The domestic rubber supply is alive and well, producing a stable supply for the modelers of this and many other countries.

Ed noted that his sales were up considerable this year over last. For example, in all of 1987 he sold 6,000 boxes of the stuff. This year, as of the end of April 1988, he had already sold 4,000 boxes. So, if you are in need of the usual high-quality rubber that FAI Model Supply has sold since 1973, you can still get it. And you will be able to continue to get it. See their ad right here in the pages of *Model Builder* to place your order.

### SCATTER RETURNS

One of the premier newsletters in the world has made a modest re-entry to the field of the modeling press. Scatter, the newsletter of the Southern California Aero Club, a strong FAI-oriented organization, has reappeared. Currently, the newsletter is intended as a club publication with a scaled-down view of its contributions to the free flight community. However, if the quality of the past is any indication, it will soon become a leader once again. As it is only available to members of the SCAT club, the only way that you can get on their mailing list is to join up. Now, I don't know what their dues are, but I'll give you the name of the guy who can tell you. Contact Craig Cusick, 20134 Gresham St., Canoga Park, California 91306. Enclose an SASE for a rapid response. You too can become a member and begin receiving a very famous and informative newsletter. To whet your appetite, I have excerpted a column by Bill Bogart from Issue Number 9 for your edification:

### "No Right Thrust-Right Thrust"

by Bill Bogart

"Rubber-powered outdoor models predominately turn right under power because the flier is right-handed and because of the way the motor is wound. The nose block is given right thrust to counter the propeller torque effects that would roll the model to the left and into the ground. That happened to me in my early rubber flying days by putting the noseblock in an Un-

# Great Planes PT Series – the overwhelming choice in trainers.

At last – trainers  
that really are  
trainers!



## Perfect in your workshop.

The quality is obvious as soon as you open the box of a Great Planes PT-20, PT-40, or PT-Electric Perfect Trainer. It all starts with the finest hand-selected balsa, ply, and bass woods. Parts are already notched and pre-shaped for a perfect fit, and a generous supply of hardware is included, so your first building experience will be easy and enjoyable. The PT-Electric even comes with a complete Thruster 550 motor package.

Full-size plans and easy-to-follow step-by-step, photo-illustrated instructions guarantee that you'll make all the right moves during construction and finish with a perfectly built model.

## Perfect at the field.

When you take your great-looking PT to the flying field, you're in store for great training and great flying as well. You'll be amazed at how quickly you can get in the air, especially with the PT-Electric – just charge your battery and fly! The high-lift wings, straight-forward aerodynamic design, and sturdy tricycle gear turn early takeoffs and landings into terrific confidence-builders.

When you're comfortable at the controls (and it won't take long!), the Perfect Trainers let you become more adventurous as you move up to performing simple aerobatics.

## Perfect in the air.

Smooth and steady in the air, the PTs are so stable and slow-flying that you'll recover "hands-off" from almost any predicament. Merely let go of the sticks and the plane will right itself! With a Great Planes Perfect Trainer, you're always in control.

Whether you prefer gas or electric power, the PT-20, PT-40, or PT-Electric will be the start of a wonderful, life-long hobby. You'll want to head to the flying field at every opportunity because the Perfect Trainers are more than trainers – they're a flying experience. Great Planes can give you the flying habit you'll never want to break. See the PT-20, PT-40, and PT-Electric Perfect Trainers at your favorite hobby retailer and start earning your wings today.



There are three Great Planes Perfect Trainers – and your local hobby dealer can help you choose the PT that's right for you. Remember, the safest and easiest way to learn to fly is with a qualified instructor, so consult your hobby dealer for more information about finding an instructor and getting started in R/C flying.

 **GREAT PLANES**<sup>™</sup>  
MODEL MANUFACTURING COMPANY  
P.O. BOX 721 URBANA, ILLINOIS 61801



**N. W. MODEL EXPO '89**  
**THE PACIFIC NORTHWEST'S LARGEST MODEL SHOW**  
 OVER 80 MANUFACTURERS—SWAP SHOP—HUNDREDS OF MODELS—CONCESSIONS  
 AIRCRAFT—BOATS—CARS—RAILROADS  
 INDOOR-OUTDOOR R/C CAR RACING—BOAT DEMONSTRATIONS IN OUTDOOR POOL  
 CONTROL LINE DEMONSTRATIONS—R/C HELICOPTER DEMONSTRATIONS

**FEB. 4th - 5th**  
 9 AM-6 PM SATURDAY  
 10 AM-5 PM SUNDAY

ADULTS: \$3.00  
 CHILDREN (6-12): \$1.00 w/adult  
 SENIOR CITIZENS: \$2.00

**NEW PAVILION & EXPO HALL**  
**WESTERN WASHINGTON FAIRGROUNDS**  
**PUYALLUP, WASHINGTON**  
**FREE PARKING**

*Sponsored by the Mt. Rainier R/C Society*



FOR INFO. CONTACT  
 DON SWEASY  
 (206) 847-1279  
 P.O. BOX 73939  
 PUYALLUP, WA 98373

OR BOB BEAN  
 Evenings: (206) 848-0160  
 (PACIFIC TIME)

turn your printer into an airfoil plotter with.....  
**FOILED AGAIN!!**



- PLOT AIRFOILS IN ANY CHORD TO 24 INCHES\*
- MODIFY THICKNESS, CAMBER, TRAILING EDGE
- PLOT SKIN THICKNESS FOR SHEETED WINGS
- ENTER DATA EASILY WITH BUILT-IN EDITOR
- EASY TO USE, MENU-DRIVEN OPERATION
- INCLUDES AN 18-PAGE ILLUSTRATED MANUAL
- IBM version only

**\$39.95** CA residents add 8% tax  
 Overseas orders: bank draft for US\$50  
 Requires IBM-compatible or Apple-compatible computer and dot-matrix printer.

Please specify computer and printer type when ordering.  
 Send check or money order to:  
**CYGNET Software**  
 24843 Del Prado #141 Dana Point CA 92629



**FIBERGLASS PARTS**

OVER 237 COWLS FOR KIT OR SCRATCH BUILT MODELS. ALSO OVER 34 ROUND COWLS RANGING FROM 4" to 14 7/8" DIA. & 55 DIFF. SIZE & SHAPE WHEEL PARTS.

*We custom make parts and vacuum form canopies.*

Please send \$1.00 for complete list

**T&D FIBERGLASS SPECIALTIES**  
 30925 BLOCK, DEPT. 6, GARDEN CITY, MI 48135  
 PHONE (313) 421-6358  
 BRAZED & HEATTREATED WIRE GEARS & CABANES  
 PHONE (313) 261-9064

limited upside down. Instead of right and down thrust, it had up and left, crashing in a half roll, and 1-1/2 seconds after launch. Scratch one Unlimited. I promised myself to devise a system that would not let that happen again. Today, it is handled by locating pins or flats in the fuselage front end opening that receive the noseblock in only one position. Learn by experience or think of it ahead of time.

"Anytime there is a misalignment between the prop shaft and the motor, some energy is lost to the propeller. Recently, I thought of a way to provide right thrust without shimming the noseblock. Right rudder is one possibility. It tends to make the ship sideslip to the left, causing the left wing to increase its lift and roll the ship to the right, and then into the ground. The ship must have a right sideslip while climbing right, to counter the right thrust effect. Left rudder during the climb will provide for the right sideslip. Bob White has built many wings where the right wing is longer than

the left with a bit of right inner panel washin. This reduces the rudder deflection requirement. Also, he makes the left wing heavier than the right for glide trim by using heavier wood.

"Now then, if the right wing is made five to six inches longer than the left, the center of gravity of the airplane will be about 3/4 inch to the right of the pylon. This offset is equivalent to three to four degrees of right thrust without touching the noseblock of a Wakefield model. With this much wing on the right side, less washin is required. But a bit more wing dihedral is required to counter the left rolling tendency in the glide."

**BUILDING TIPS FROM TERRY T.**

One of these days, I am going to have to back through all of the *Model Builder* Free Flight columns and collect each one of the building tips that have been included in the 14 years since I have been the columnist. There must be over a hundred. One of the very best tip givers these days is Terry Thorildsen, master AMA gas flier and member

of the San Valeers. Terry sends these tips to *Satellite* editor, Ralph Prey, for inclusion in their club newsletter, but this time he sent me an advance copy. So here are four new ones just for you. (See sketches elsewhere in this issue of *Model Builder*.)

"Building Tip #1: On 1/2A and smaller engines I use a Cox Clip for my glow plug. These are too short to start with, so a good way to lengthen them is to solder an old extension cord from a broken appliance to the wires to get the proper length. The extension cord is always quite heavy gauge wire, which avoids current losses with thinner wire. The clips tend to break at the solder joint to the clip due to the constant bending stress that they encounter. To alleviate this, take some G.E. Solicone adhesive and put it in the back end of the clip to take the stress from pulling on the solder joint. This effectively strain relieves it. They will last a lot longer this way, and, after you fire up your engine, you can just jerk on the cord to yank it off the engine without fear of breaking it. I also keep a spare in my starter box in case it does eventually break.

"Building Tip #2: Are you tired of the nicks and stress cracks in the front of your pylon? A good way to avoid them is to put a small strip of spruce at the front. It will stand up to a lot of abuse when you jerk your glow clip off, and it seems to completely eliminate the stress cracks from the front of the pylon. I just use different sizes for the type of model involved. For a 1/2A, I use a 1/16-inch square, and I just increase the sizes for larger models.

"Building Tip #3: At the 1988 Free Flight Champs, Hank Sperzel had a neat model carrier attached to the back of his trail bike. It was made out of 1/2-inch PVC pipe glued together and was covered with the real soft foam insulation like they put on pipes in solar water heater installations. The model was fastened down with Ace bandage material. You just set the wings in place and wrap the Ace bandage around each side. Your hands are then free for the ride back. (Note: This might be just the ticket for flying at Stead AFB for next year's SAM Champs—see article below.—bs)

"Building Tip #4: Have you ever had a d.t. fuse that was too tight so that it occasionally went out? To avoid this problem, every time I buy a new roll, I fluff up the fuse so that it will burn better. I do so by holding it between my fingers with about one inch of fuse in between and pushing it together. I go over the whole roll this way, and it eliminates that sick feeling when your fuse goes out. Another problem area can be if you cut a long length of fuse, put it in through your fuselage, and slowly pull it out as you make a bunch of test flights. By the time you get a few flights in, the fuse can become oil-soaked and go out. So be careful here as well." Terry's tips remind me of what Sal Taibi is quoted as saying earlier in this column, "you learn from your mistakes." Terry has given us the benefit of his learning. You can take his advice, or learn from your own mistakes.

**WHATEVER HAPPENED TO GEORGE BENEDEK?**

One of the giants of the free flight hobby, George Benedek, the fellow for whom an

entire line of competition airfoils is named, has been out of the model press during the last decade or so. From my point of view, I figured that he had given up the hobby or perhaps had decided to leave us forever. I was pleasantly surprised to receive a letter a while back from Fritz Mueller of Columbus, Georgia, with some information about George. He is alive and well in Czechoslovakia, and he is still flying free flight models. Fritz sent along a three-view of his current CO<sub>2</sub> design. I will be covering the model, and a bit about what George is doing these days, in the next issue of *Model Builder* Free Flight.

#### RENO FREE FLIGHT SITE AND WHAT HAPPENED TO THE 1988 NATS

I just read a brief report in the *Satellite*, written by Mike Myers, about the flying site at Stead AFB, just north of Reno, Nevada. This was the venue for the AMA Fun-Fly, held in late June. Mike's comments are generally positive, noting that the site is large, 3.5 miles from north to south and between 1 and 1.5 miles east to west. The land is generally flat, and when you get beyond the cleared area, the site is either filled with "pucker brush" or ringed by hills. Mike did report that he watched his Shocer 600 glide in even though it was over a mile away. That sounds promising.

One apparent drawback with the site is that the ground is sandy and loose, so much so that riding a regular trail bike is difficult at best while carrying a model. Some modelers apparently chased in cars, and wide-tired ATVs seem to be able to handle the terrain.

It seems as though the Reno location has to hold promise for a future Nats site. This is especially so since I just read in the *Brainbuster* newsletter from Newport News, Virginia, that the free flight portion of the 1988 Nationals has been cancelled due to the loss of the intended site. Our site troubles continue to mount as we continue to try to make the Nats fit a single available location rather than change the Nats to a multiple-location event.

#### THAT'S IT DEPARTMENT

Thanks for coming along this month. It looks like a good year for outdoor free flight is coming to an end. To me that means it's time to start planning and building for next year. Think of what you want to build between now and next month. I'll share my building plans with you. Until then, catch a good thermal for me. •

**Choppers. . . . Continued from page 13**

#### LET'S DO ONE!

Fly your helicopter into position, about 100 feet high, heading into the wind with some forward speed, throttle anywhere from half to full. The position of the helicopter should not be directly overhead, but a comfortable distance downwind so that the touchdown will occur a short distance *upwind* of where you're standing, just as you would do in a full power landing. The flight path of the auto should not be directly *towards* you. It's better for everything to take place in front of the pilot, where the rate of descent, the attitude of the chopper, and the proximity to the ground can be

## JTEC MAKES IT EASY!

**Authentic Scale Instrument Kits  
Museum Quality Results**

- A selection of 83 assorted instruments including first time ever, WORLD WAR I
- 20 Instrument bezels with clear plastic faces. Instrument rims are thin, true to life.
- Simple, new method of making instruments produces fantastic looking instrument panels.
- Detailed instructions show various methods for making general aviation, cars, boats, military and World War I instruments.



WORLD WAR I  
Standard Aviation  
Cars - Boats  
Military

Scale	Instrument Sizes	
JT-3	1/3 1 1/16" & 1"	8.50
JT-4	1/4 1/2" & 3/4"	8.50
JT-5	1/5 3/8" & 5/8"	6.50
JT-6	1/6 5/16" & 1/2"	6.50
JT-7	1/7 9/32" & 7/16"	6.50
JT-8	1/8 1/4" & 3/8"	5.50
JT-9	1/9 7/32" & 5/16"	5.50
JT-10	1/10 3/16" & 5/16"	5.50
JT-12	1/12 5/32" & 1/4"	5.50

Complete package contains 83 assorted instrument faces, 20 instrument bezels with clear plastic faces, and detailed instruction sheet.

If not available at your hobby shop, ORDER DIRECT for immediate shipment. Check, MO, COD accepted. Add \$1.50 for UPS, \$2.00 for COD, and 6% tax for Calif.

**164 School St. Daly City, CA 94014**  
**(415) 756-3400**

## JOHN POND Old Time Plan Service

The largest selection of plans in the world at the most reasonable prices. Each list \$1.00

- No. 18 OLD TIMER F/F GAS
- No. 18 OLD TIMER RUBBER/TOWLINE
- No. 18 OLD TIMER FLYING SCALE A through K
- No. 18 OLD TIMER FLYING SCALE L through Z

New plans prices effective Jan. 1988 to Dec. 1988

**P.O. Box 90310**  
**San Jose, Calif. 95109-3310**  
**Phone (408) 292-3382 (Tues. or Fri.)**

clearly in view.

Fly your chopper downwind, make a slow-procedure turn into the wind with enough airspeed to keep the nose level and pointing into the wind. As soon as your machine is in a good position (positioned downwind, heading into the wind, slow forward speed, and level), smoothly lower the collective/throttle. The helicopter will start to drop fairly rapidly. Calmly hit the throttle hold switch. As the helicopter falls, make whatever cyclic corrections are needed to keep it on line, and generally level with a slight nose down attitude. Before you know it, the time will arrive where you have to start slowing it down. At 20 to 25 feet start pulling some back cyclic. Wait a fraction of a second, and you will see a fairly sudden leveling out and slowing down. A lot of the straight down velocity will be changed to forward motion. Continue adding just enough back cyclic to reduce the forward speed, but make sure the helicopter continues to descend.

When you get down to two to three feet, your helicopter will be in a nose-high flare, and forward speed should be little to none. Push the nose back down with the fore-aft cyclic and smoothly start adding collective pitch. Again, don't add more collective than you need or the helicopter will stop in midair. You want it to continue coming down, but *slowly*. Use your cyclic control to make sure the landing is level. Your autorotation is complete!

tation is complete!

#### HINTS

**Boom Strikes:** 95 percent of the time that a helicopter is damaged in an autorotation, it is the result of a boom strike. A boom strike occurs when one or both of the main rotor blades strikes the tail boom. Usually the tail boom is severely bent or broken, the rotor blades may crack, the rotor shaft may bend, and the frames may bend. Boom strikes are caused by an oscillation in the rotor disc, usually the result of a bad landing. Even a soft landing will result in a boom strike if the helicopter isn't level at touchdown.

**Induced yaw:** Except for the optional "driven tail" available for Heim and X-Cell helicopters, tail rotor steering is not available in an autorotation. Therefore, if yaw is induced (the tail drifts right or left) there is no good way to correct it. To help avoid inducing yaw, you can do the following: (1) Don't lower the collective too rapidly when initiating the auto. (2) Keep the heading directly into the wind. (3) Don't add collective faster than you have to at the bottom of the auto. (4) Absolute minimum friction in the autorotation clutch and main shaft is very desirable.

**Engine idle:** Often it's difficult to set a dependable idle that's low enough to allow the clutch to disengage. As the engine heats up (as it invariably does in a helicopter) it won't always come down to an idle from full

# CHUPEROSA

(Hummingbird)

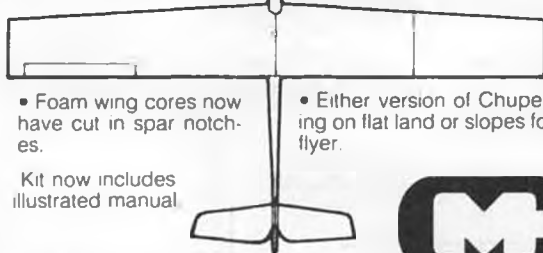

• Foam wing cores now have cut in spar notches.

Kit now includes illustrated manual.

• Either version of Chuperosa will provide easy relaxed flying on flat land or slopes for the beginner or the experienced flyer.

• A quality 1½ meter (59") glider kit, complete except for 1 roll of covering and adhesives (CA & epoxy).

• Coupled aileron/rudder, elevator for those with some experience-\$41 S&H \$3.

• Rudder, elevator w/polyhedral wing for beginners-\$36 S&H \$3.

## CULPEPPER MODELS INC

2526 Washington, Dubuque, IA 52001 319/583-4830

Basic Design-Russell A. Shaw  
Redesign. Plans-Leroy K. Satterlee



## Al Tuttle switched to Micafilm because

When it comes to gliders, he wanted a film that was ultra light, yet tough enough to withstand rough landing areas. Micafilm filled the bill because it's 7 times tougher than any other film . . . yet ½ the weight.

### COVERITE

420 Babylon Road, Horsham, PA 19044 USA

throttle, particularly if a tuned pipe is used. If the idle isn't low enough to allow the clutch to disengage, the rotor speed will be too high at the end of the auto. You've got a situation where it's a power half-on, half-off landing. The danger here is to put in too much collective, and have your helicopter start to take off. The solution: just be cool, and don't panic. Add collective a little more slowly and carefully, and you'll be okay. On the other hand, the idle may be too slow or irregular, and the engine may die on the way down. This won't be a problem *unless* you were thinking about turning the throttle hold off and aborting the auto. Solution: avoid doing autos with the thought that you

## HI-PERFORMANCE FOLDING PROPS

Send SSAE for catalog sheet on our complete line

**K and W ENTERPRISES, INC.**  
7824 Lexington Ave., Philadelphia, PA 19152

### Carbon Fiber

RC, Free Flight, Rubber, all categories!!  
Save weight, stronger, we tell you how.  
Send \$3.00 for 30 feet of our new CF tape,  
(.100 x .005), and booklet. Check, MO ok.

**HOBBY TECHNICS** No cards.  
P.O. BOX 26794 • ELKINS PARK PA 19117

can hit the switch and fly out of it. That's always a dangerous practice.

### OTHER USES OF AUTOROTATIONS

**Emergency bailout:** Loss of tail rotor is far and away the most common mechanical failure that occurs in a helicopter. When this happens the helicopter generally starts spinning rapidly from the unopposed torque of the main rotor. The best reaction to this failure is to cut the throttle, hit the hold switch, and auto down. By allowing the rotor to freewheel, you have eliminated the torque, and with a little luck, your chopper will stop spinning and float down to the ground.

When the engine leans out and starts to sag, cutting throttle and hitting throttle hold is a good way to save the engine *and* the helicopter. Pinion gears that separate from the clutch bell, stripped main gears, disconnected fuel lines, unscrewed pressure taps, broken mufflers, broken control rods, malfunctioning servos—these are just a few failures that can destroy your helicopter. An emergency auto might be the thing that will save it.

### SUMMARY

(1) Set up the proper amount of low-end pitch so your descent is neither too fast nor too slow. Usually this is two to four degrees negative pitch.

(2) Get comfortable with using the throttle hold switch.

(3) Set the throttle hold so the engine will "hold" at a low but reliable idle.

(4) Smoothly lower the collective/throttle,

don't jerk it. Then calmly switch on throttle hold.

(5) Fly the chopper down using cyclic to guide it. At about 25 feet or so start gradually pulling back on the stick and if necessary add a small amount of collective pitch.

(6) Continue pulling back on the stick so the chopper comes to a complete stop no more than three feet off the ground.

(7) Give forward stick and right or left cyclic to level the chopper, then feed in the remaining collective pitch as needed in the last three feet to allow a soft, level touchdown.

Remember to fly the helicopter through the auto. Don't worry too much about having enough rotor speed at the end; it'll be there.

### Plug Sparks. . . Continued from page 30

This writer built one in the "good old days" to suit a McCoy 49. The Hurricane 69 handled the power excellently, a tribute to the model's stability.

Scheduled for production on May 15, by the time this notice comes out, the kit should be readily available.

### MCCOY PARTS

From Dick McCoy Model Engines, 5674 San Bernardino St., Montclair, California 91763, comes several sheets listing parts available for McCoy 19, 29, and McCoy 60 Series 20.

All sorts of parts, such as Venturi, needle valve, piston rings, con-rod, and cylinder sleeves, are available at fairly reasonable prices. Dick points out the main crankcase castings for any engine have been long gone, cleaned out by the collectors.

Some auto race car parts such as Tear Drop Car spur gear, front axle for Invader Car are available. Best idea is to write Dick McCoy requesting his catalog sheets.

If you can't wait, ring Dick at (714)626-5054. All Dick asks is that you don't ring him after 8:00 p.m. A guy has to have some privacy!

### EASY BUILT KITS

Here is a switch! Received a letter and photos from Ian L. McQueen, 2-18-7 Kami-Meguro, Meguro-ku, Tokyo, Japan, who builds and flies Easy Built models as manufactured in Canada!

Ian also enclosed a catalog from Easy Built Models, Box 12, Gremesley, Ontario L3M 4G1, Canada, showing a large selection of flying scale models, rubber endurance models, and no less than four gas model kits.

Most of these kits are reissues of the models produced before and directly after the war. Of the photos sent in, the Fairchild Ranger seen in Photo No. 16 is easily one of the best jumbo scale models. This 54-inch design can be used for rubber, small gas, or electric.

Ian is so enthusiastic about EB kits, he has formed an "Easy Built Friends" club. This association builds only the EB designs. Ian is just delighted that the old Modelcraft (Ontario) has been taken over and excellent kits being produced.

Easy Built kits are sold by mail order; however, Russ James of A J Free Flight Ser-

# SHELDON'S HOBBIES

## POSI-CURE™

### CYANOACRYLATE SALE

## WE'VE GOT THE CURE

We've got the cure whether you're torn, ripped, shredded, frazzled, smashed, crushed, cracked, chipped, fractured, split, snapped and shattered or just a little bit stressed.

- 1 oz. Fast Cure 3-5 Sec. . . . . \$2.49
- 2 oz. Fast Cure 3-5 Sec. . . . . \$3.96
- 1 oz. Gap-Filling 10-25 Sec. . . . . \$2.49
- 2 oz. Gap-Filling 10-25 Sec. . . . . \$3.96

If you are not satisfied with POSI-CURE please return the unused portion within 30 days for a full refund - No questions asked!

#### SHELDON'S HOBBIES

2135 Old Oakland Rd. • San Jose, California 95131

**ORDERS (800) 228-3237** OUTSIDE CALIF.  
**ONLY (800) 822-1688** INSIDE CALIF.

For Information Call: (408) 943-0872

**SHIPPING** - U.P.S. Surface Add \$5.95, U.P.S. Air Add 10%  
 Parcel Post Add 10%, Parcel Post Air Add 15%, C.O.D. Add \$2.50

**HOURS** Mon & Fri 9:50-7:30, Tue Wed & Sat 9:30-5:30, Thurs 9:50-9:00, Sun 12:00-5:00



vice has been stocking quite a few kits. Give him a try!

#### VINTAGE CLASSIX

Received some very informative information from Bob Fenske, who is dedicated to collecting, preserving, and disseminating model history.

Operating under the name, "Vintage Classix," Bob's consuming interest has been models and their history. Some time back, we reported his activity in tracing the origin of the Tiger Shark as a descendant of the Curtiss P-37. One would never think of this unless the side profiles are placed side by side.

Fenske embarked on a program of producing reduced versions of the Tiger Shark. This can be seen in Photo No. 17 together with a full-scale Super "G" Shark. Fenske has been producing these miniatures for \$34.95, assembled and painted. If you wish to do your own painting, then the fully primed Shark costs \$24.95 plus \$3.00 for shipping and insurance costs.

Bob Fenske has discontinued all advertising, as the hard work involved took up too much time. As he says, "The memories of late nights spent sanding, filleting, and painting have faded." An offer of help from a fellow modeler has convinced Bob to give the project another shot.

The models were originally scheduled to be airbrushed, but it turned out that hand painting the trim was so much more satisfactory. Fifteen went into the waste basket because of paint problems.

The small Shark reproductions are accurate in all details, as Bob reproduced his hardwood master into RTV molds. Bob also comments this was no easy task, as all molds were made twice or better. Truly a love of labor!

Fenske also has a list of kits for sale. To get



a list, write to Vintage Classix, P.O. Box 87, Elgin, Minnesota 55932. If you are lazy, and don't want to write, call Bob at (507)876-2020. He has both plastic and wood construction kits from Aurora to Continental.

#### THE WRAP-UP

Seems like obit notices are unavoidable,

### CANOPIES & SHADES

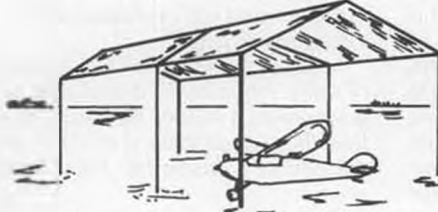
**TIRED OF TRIPPING OVER ROPES AND STAKES?  
 TIRED OF BLOWING AWAY?  
 CAN'T SET UP ON PAVEMENT?**

★ Extra Strong Galvanized Steel      ★ Heavy Duty Steel Fittings

These are the same rigid frame sun shades used by the Academy of Model Aeronautics for official shade at the Nationals since 1983.

Fast set up by one person, compact storage, available in two styles, flat top or peak top. 12 sizes available from 8 x 10 to 20 x 30. Tops available in blue, white, silver and sunscreen. Prices start at \$75.00 complete F.O.B.

**CLUBS: Shade the entire pit area, safely and economically 40' to 60' specials.**

**JED'S SHADE CANOPIES**  
 643 S. Brookhurst Ave.  
 Fullerton, California 92633  
 (714) 773-9509

# PUSH RODS

AND LINKAGES  
ANY WAY YOU  
USE THEM  
ADDS UP TO  
BETTER  
PERFORMANCE

---

## NYROD® THE ORIGINAL Flexible PUSH ROD

COMPLETE WITH ALL REQUIRED METAL FITTINGS  
IDEALLY SUITED FOR ANY PUSH ROD ACTION:  
RUDDERS, ELEVATORS, AILERONS, THROTTLE CONTROL, BOATS, SEA PLANES... YOUR IMAGINATION  
34" LONG, ASSEMBLED LENGTH

**HARDWARE INCLUDED:**  
1-4" NYRODapter  
1-8" Rod with 2-56 Threaded end

PUSH ROD  
STANDARD  
SINCE 1987

**\$1.79**  
Cat NYROD

---

**SU-PR-LINE PRODUCTS, INC.**  
18900 States Route, 47 E  
Sidney, Ohio 45385  
Ph. (513) 498-1721





## FLYING T MODEL COMPANY





# Antique & Vintage Premium Aircraft KITS

For catalog send 1st class stamp to

Roger Teagarden 1234 N. Edgemont St # 204 Los Angeles, CA 90029  
213-662-9323



but in the case of Claude DeBeneditto (known more familiarly as "Ditto"), a death at the age of 61 was a blessing. Claude, who had everything going for him; successful store, enviable engine collection, and many years as an O/T flier, was struck down with a stroke.

Committed to a sanitarium, all his model equipment was sold off at "bargain prices" by relatives in his absence. Truly a bad scene! Claude finally succumbed to heart problems on July 10, 1988.

"Ditto" will be remembered for his numerous SAM cartoons that appeared in the *Engine Collectors Journal*. Even at this late date, his cartoons are still being used to head up various columns and newsletters. As Tony Italiano (NFFS President) states, "Say a prayer for Claude Ditto every time you see one of his art pieces." While at the SAM Champs in Indiana, this reporter received notice that longtime modeler, "Lucky" Moody died in a glider accident.

Moody was a very active modeler while in the Southern California area, being a member of the San Valeers. When he moved north to Eureka, California, he set up a small kit manufacturing business based notably on the Modelcraft 30-inch Pacific Ace. This was quite successful and contributed mainly to the renaissance of a "Pacific Ace Only" rubber event staged by SAM 27 at their annual at the Olive Racket Club.

One thing for sure, Lucky is going to enjoy meeting his old buddy, "Civvy Boy" Paul

Gilliam, who preceded him by a year or so.

One more item came in: Merl Shammo of Florida recently passed away. The old timer movement lost one of its staunchest advocates! Truly a shame as Merl was still fairly young as old timers go.

**Old Timer...** *Continued from page 30*

*Strangely enough, it was found almost at the spot I had been standing on when it sailed away over the bay! Obviously, it had made a round trip over-water flight and returned to dry land!*

*A really grand send-off was given the last of these jobs I built. It was attached to a government Weather Bureau altitude balloon that was set to burst at 55,000 feet. You guessed it! Nothing has been heard of it since.*

Well, chances are the last one was dragged down by the remnants of the balloon after bursting, unless they figured a way to release it at the moment the balloon burst. However, it is certain that you should not even think about flying one of these gliders now without a dethermalizer, and the design is such that a stab platform and D/T setup will be easy to install.

Construction of the whole model is pretty much standard, but there are a few points that might need clarifying. Strangely enough, Joe did one thing opposite to normal. He built the wing onto the fuselage, but attached the tail surfaces with rubber!

We'd sorta opt for making them both removable, especially for D/Ting the tail. He built the wing in one piece, partially cut the LE, TE, and main spar at a point between ribs, raised the tips for the 1-1/2-inch dihedral, then glued the joints and sprung the top stub spar into place. This would seem to leave rather an awkward situation when it comes to covering. We've shown a rib at the dihedral break.

The rudder trailing edge is just begging to be made up of laminated strips... either four of 1/32 or two of 1/16, and we'd prefer to make a splice joint at the leading edge of the stab, D/T or not. The photo from which the line sketch was made discloses a strut, probably about 1/16 x 1/8, from the middle stab rib up to the lower rudder rib. It hits the rudder rib about 1/3 back from the leading edge.

Speaking of 1/3, that's about where you may want to start with your balance point, 1/3 of the wing chord back from the leading edge. Balancing is mentioned in the text, but as usual for those days, it didn't say *where!* Not only that, you're instructed to glue the correct amount of nose weight *behind* the noseblock, and then remove or add as necessary to get a flat glide. Gluing the weight to the *back* of the noseblock after the plane is all covered and ready to fly has to be the neatest trick of the week!

Ya know, after all these years, it just occurred to us that maybe, just maybe, Joe Weathers designed this model for rubber power. Make that noseblock removable, add an eight to ten-inch prop, and attach a wire landing gear to drop those wheels down about five inches... hmmm... •

**R/C Soaring...** *Continued from page 39*

ponents onto paper. Use these paper silhouettes to make a side-view fuselage shape that is pleasing to you, but still able to contain the components. Remember to leave room around each component for wires, foam, etc. and above and below for fuselage roundness. An on/off switch is not used.

Make a template of the fuselage side view and trace this shape onto a slab of blue foam wide enough for two servos side-by-side, plus a little extra. Remember that the silhouette is going to have a "hump" where the wing saddle is because of the undercambered airfoil. Cut out the silhouette.

About three inches from the rear of the pod you should place a bulkhead. The shape of the bulkhead will be the cross-section of the fuse at this position, so make it flat-topped for the wing saddle, and a nice oval or ellipse on the bottom, you decide, and make a hole for the front end of the arrow shaft where indicated. When you have the bulkhead you want, slice the pod in two at the correct location and epoxy the bulkhead in place.

You might want to draw a centerline around the pod as a reference guide before rounding the pod into shape. Remember that the pod tapers to a 1/4-inch circle at the tail boom, so if you think this might be hard to achieve (I do), carefully insert the fiberglass arrow shaft tail boom in through the rear of the pod and into the hole in the bulk-

head. You can do this by first drilling a 1/4-inch pilot hole. You will need to create a special tool: cut a sawtooth pattern on one end of a 1/4-inch K&S brass tube using a file, or ream the tube into a razor sharp edge, then use a makeshift alignment jig to guide the brass tube while you drill. Books and sand bags can hold the pod, and a couple of notched pieces of wood, aluminum channel, etc. can guide the drill. You may have your own ideas on how to do this.

With the bulkhead and tail boom in position, you can really shape up the pod in a hurry. When it is shaped to your satisfaction, sand it with fine paper to get it really smooth.

Cut four pieces of two-ounce fiberglass cloth just large enough to reach a little past the centerline of each pod half. Put on your gloves and start mixing some slow cure epoxy. When mixed, place one cloth on one side and begin brushing epoxy resin through the cloth. Avoid putting any cloth on the flat wing saddle area. Flip the pod over and do the other side. Repeat until two layers per side are laid up, and then set it aside to harden. When partially hardened, you may find it easy to trim away any excess cloth hanging over the wing saddle area.

When the epoxy is fully hardened, cut an access hatch in the top of the pod using an X-acto No. 1 knife with a new No. 11 blade. Repeated scoring rather than one bold cut-through does a nicer job. It won't take long to cut through, but be careful not to slip when you cut. Remove the hatch.

Pour acetone or methyl ethyl ketone (MEK) into the fuselage to dissolve the foam. It is a messy and potentially harmful step that must be done outdoors, preferably in a breeze, and preferably with you wearing protective gloves! Dump the resultant slime into a used coffee can, and place it outside away from kids or animals, and let it evaporate. Then throw it away.

You now have a "molded" fiberglass fuselage. It will be as rough as the cloth weave on the outside and even rougher inside. The outside can be filled with K&B SuperPox primer paint and repeated sandings with 400-grit. Use whatever paint you desire for final color, avoiding lacquer-based paints.

Inside, you can sand what you can reach with your fingers and a small piece of 320-grit. There are only two things which will need to be glued internally at this stage: servo rails and a pushrod tube holding former. The rails can be made from a tray of 1/8 lite ply, two sticks of bass wood, or your choice of materials. Glue them to the fuselage with epoxy after checking the CG (see below). The former which holds the pushrods can be 1/16 ply. Drill both rails and former with appropriate holes before installing them.

The tail surfaces are next. Sheet balsa wood surfaces are not hard to make, so I won't go into detail here. Coat them with thinned epoxy and let harden. Temporarily tack glue them in place on the boom.

Insert the pushrods and music wire antenna into the tail boom. Make sure that when you make your antenna that its overall length is not changed. Put in the radio gear. Rubber band the wing on the saddle

**MERCO**

**MERCO C/L & R/C ENGINES**

SEND \$2.00 FOR CATALOG

**CLASSIC REPLICA CL PLANS**  
**BOLLY COMPOSITE PROPS**  
**MERCO PARTS & SERVICE**



**Tom Dixon**

193B Peachtree Road Suite 401  
Atlanta, Georgia 30309

NEW  
DRAWINGS

Old Timers & Antiques  
For your Reed Valve Engine

- Diamond Zipper
- Flying Quaker
- Red Zephyr
- Miss Philly
- Eaglet
- Commodore

1/4A \$4.00 1/2A \$5.00

STAZLIT FUSE

10' - \$3.99 15' - \$4.99 25' - 5.99

1987 Illustrated Plans Book \$2.99

B & D MODELS

P.O. Box 12518

Reno, Nevada 89510

*Home of the  
New Race*

and check for CG. If it isn't right, you may need to shift things around. You may even need to mount the servos forward of the receiver (center of the hatch area), and put the receiver under the wing, there is room.

Mark the positions on the boom where you think the Sullivan Small Gold'N Rod tubes should exit. Take a Dremel tool with a small grinding wheel and make slots wide enough for the pushrods to be inserted. Install the pushrods from the rear toward the pushrod former and anchor it there with epoxy. As a last step before gluing the wing to the saddle, you can push small chunks of styrofoam or foam rubber down the tail boom about four inches apart to firmly hold the pushrod tubes in place and give solid control. Epoxy the tubes in place where they exit the tail boom.

Permanently glue in the rails, former, and arrowshaft's front end with epoxy. Drill a hole through the pod where indicated for a 1/8-inch hardwood dowel. This will serve as the forward rubber band hold down. Flip the wing over, protect it with a layer of Saran Wrap, and make a 1/4-inch radius wing fillet of micro balloons and epoxy for pod strength, gap sealing, and drag reduction. Let it cure and remove wing and plastic.

Glue the stabs in place permanently. You might even want to make a very small fillet of glue at each joint for strength and durability.

The elevator and rudder hinges are cellophane tape. The horns are merely 1/32 ply. Z-bends are adequate for both ends of



**TELEFLITE**  
CORPORATION



**BUILD YOUR  
OWN ROCKET  
MOTORS!**

**WE CAN SHOW YOU HOW!**

- 40 POUNDS THRUST!
- 50¢ EACH!

- With a rock tumbler and some simple hand tools we'll show you how to build **YOUR OWN** rocket engines in your own garage or workshop for 1/5 to 1/10 the cost of the commercially marketed motors
- **INTERESTED?** Just send us \$2.00 and we'll mail you our brochure along with a **WORKING SAMPLE** of an electric igniter that **YOU CAN MAKE YOURSELF** from materials you'll find around the house

**TELL YOUR FRIENDS ABOUT US! We're the OO IT YOURSELF ROCKET people**

Write to: Department MB11 The Teleflite Corporation  
11620 Kitching St., Moreno Valley, Calif. 92387-9978

the pushrods, plus they save the weight of clevises and couplers. A drop of flux and an application of silver solder to the brass cable will make it stiff enough to accept the forward Z-bend. The rear Z-bend will be made from music wire. A short section of small brass tube will act as a solder link between the brass cable and the music wire Z. It will also allow for slight adjustments in trim.

The wing is attached to the pod by sliding the appropriate rubber bands over the pod and onto the tail boom. Two or four will be needed depending on the tension after being stretched six inches. Place the wing on the saddle and bring the bands over the top of the wing and onto the dowel pegs.

Tape the hatch on, range check the radio, and you are ready for some flying fun!

The foregoing instructions are how I would build a Skywalker based on a couple of conversations I've had with Dick. If I have omitted any steps or small details, I apologize to you and Dick, and leave them for you to solve. The Skywalker is a very simple model and really is pretty easy to build. I wouldn't think you could run into trouble using these instructions.

**NEW KITS AVAILABLE**

From time to time I receive products for review in this column. Kit reviews are very, very, time consuming, and at the present time, I am not in a position to undertake all that I am offered. I can, however, tell you what comes along as soon as it comes along, and what's inside the box.

The first kit is from a new company called Culpepper Models, Inc., 2526 Washington,

# CONGRATULATIONS 1987 NAT'S WINNERS

1st Place

MASTERS - JIM EIDE  
EXPERT - GENE MAXWELL  
SPORTSMAN - GENE RODGERS



AGAIN - OUR THANKS  
TO ALL THE  
"TIPO" FLYERS  
THIS YEAR!

Now available: TIPO+,  
TIPO 750, HIPPO TIPO (825).

Write or call for full information.

AVAILABLE DIRECT FROM  
**DICK HANSON MODELS**  
5269 LUCKY CLOVER LANE  
MURRAY, UTAH 84123

ALL SHIPPING VIA UPS  
UPS CHARGES EXTRA  
PHONE (801) 261-1402

## Eliminates GLITCH problems associated with long servo leads.



- Eliminates need for voltage robbing chokes and other devices with leads over 15" long
- Modern CMOS IC technology
- Uses less than 0.5 milliamps at 4.8 volts
- Power lines are capacitor filtered
- Available in 4 versions with connector installed:

- \$10.95 - Single Channel, single servo drive (Single) GS-1
- \$12.95 - Single Channel, two servo drive (Wye) GS-1Y
- \$14.95 - Two Channel, two independent servo drive (Twin) GS-2
- \$17.95 - Two Channel, two servos per channel drive (Twin Wye) GS-2Y

- Overall lead length is approximately 6" to 8"
- Modeler must furnish own longer extensions as required.

Specify Radio \$1.00 Shipping and Handling on Pre-Paid orders, add 6% for California residents, Mastercharge and Visa

22483 MISSION HILLS LANE, YORBA LINDA, CA 92686 (714) 777-1326

Dubuque, Iowa 52001; (319)583-4830. The sailplane model is called the Chuperosa ("hummingbird"), and was originally published in the January 1988 issue of RCM. It was designed by Russell A. Shaw originally, and was redesigned and improved by Leroy K. Satterlee.

The Chuperosa has a 1-1/2 meter (59-inch) wingspan, and can be made with either polyhedral or V-dihedral/aileron wings at the builder's option. Other control functions are rudder and elevator. The wings are one-pound density, white foam core and have the well-proven Eppler 214 airfoil. Two degrees of washout has been hot-wired into the cores. The cutting job is a little wavy and therefore not quite perfect, but it is very useable and not really objectionable. A very complete hardware selection comes with the kit, and all wood is included, high grade stuff.

The model's specs are: 59-inch wingspan; 413-square inch area; eight-inch root

chord, six-inch tip chord; 36-inch length; 13- to 18-ounce flying weight; and two-channel control (either coupled rudder/aileron with elevator, or rudder/elevator with polyhedral).

There is an incredible amount of machine work already done for you inside the Chuperosa kit. Much time and effort has gone into the pattern and jig making to assure kit quality and accuracy. This means less assembly time for you and a better value for your money. Items like fuselage bulkheads, sides, formers, and nose block pieces are pre-cut, as are the vertical and horizontal stabs.

The plan sheet is two feet wide and six feet long and shows every detail of the model full-size. The plans are rolled inside the kit. The instructions are two pages (8-1/2 by 14 inches) worth and are well thought out. They include sections on final assembly, balancing, and flying.

All in all, if you like the little ones, the

Chuperosa is one of the nicest and most complete kits around. It should fly just great in either slope or thermal conditions, and, for what you get, the price is right at \$41 plus \$3 shipping and handling. Tell Mel Culpepper that *Model Builder* sent you!

Model number two is a familiar one to readers of this column. It is the JADE Telos, a canard slope ship with some really fancy "Star Wars" styling. The kit is now available, and it is as impressive as the model's looks.

First, here's a review of the model's specs: the canard has a span of 26 inches (area 99); the main wing's span is 51 inches (area 342); the Telos's overall length is 38 inches; its weight is 27 ounces; and the radio requirement is two channels. Standard size servos will fit the Telos, but a 250 mAh battery pack is recommended.

The Telos, being a canard, flies differently than a conventional aircraft. The Telos will not tip stall or pitch violently, and it recovers from dives quickly. Telos is fast, is capable of high roll rates, flying inverted, and doing outside loops.

The model's construction is a combination of different composites. The wings are blue foam core with hardwood leading edges and balsa sheeting. The fuselage is molded epoxy and S-2 fiberglass with Kevlar and carbon fiber reinforcing strips. It is one tough part! To round out the materials, there is even a vacuum-formed clear plastic canopy.

The kit comes with many carefully machined parts and custom hardware. There is even a booklet on how to work in composite materials, and a booklet on building the model. Each booklet must have taken many score hours to thought and assembly. The plans are shown full size, but only of specific portions of the model as that is all that is really needed.

The price for the Telos is \$139.95 and is available directly from Jarel Aircraft Design and Engineering, 11367 Culver Blvd., Los Angeles, California 90066, (213)390-1348, or from a few mail order houses such as American Sailplane Designs and Hobby Shack.

## GLEANINGS FROM THE MAILBAG

The remainder of this month's news comes courtesy of you, kind readers, who take the time and effort to write in about your thoughts, observations, projects, questions, and various tidbits related to soaring month after month. My hat is off to you, and we all thank you! Without further ado, the column is yours.

## NOTHING NEW UNDER THE SUN DEPARTMENT

Many of our modern-day airfoils are really nothing more than refinements of shapes and ideas proposed 50 or more years ago. Most of the Eppler, Wortmann, and Goettgen series of high-camber, moderate-thickness, "undercambered" airfoils are very similar to earlier airfoils when thickened up a bit. Conversely, the old timer sections look fairly modern when thinned down a bit. Case in point is a letter received by R/C Soaring way back in February of 1987. Tom Matterfis of Clearwater, Florida, sent in the following brief letter with airfoil drawings:

"I have Ron Warring's 1942 Book of Air-

foils and have been thinning some of them down to 70 percent for rubber-powered models. The Eiffel 400 and RAF 32 look somewhat like the Eppler 214 when thinned. Perhaps these old foils may still be useful."

#### NEWS FROM MISSOURI AND ILLINOIS

Received early in January 1987 from Mark Nankivil of St. Louis was the following letter:

"Enclosed you'll find a photo of Gary Meissner and myself with our Muller Thermal Kings. We picked them up from Herr Muller back in August (1986) when we were over there for the F3E (electric-powered sailplane) World Champs. I know you mentioned it a while back in your column in Rick Schrameck's hands. I'm big-time in love with this plane. This is the first aileron ship that I'm really comfortable with (my Fiesta SF was so-so), and it has surprised quite a few of the polyhedral lovers around here. I'm consistently matching or beating the others on launch height and can search more air in less time. The only problem is visibility—it gets pretty hard to see when it gets out there a ways. (Rick also complained about this: *Natural wood color is very gray at a distance and blends in perfectly with any kind of haze or smog.—wrf*) I'm building a standard class version with a Quabeck 3.5/10 on a Bob Sealy Antares fuselage for the new season. . . .

"I'm also getting started on a Krik (Hobby Lobby) 1/5-scale Grunau Baby IIa. My question: Do you (or anyone else) know the best way to simulate the color and texture of the full-size ship? What I'm trying to recreate is that washed-out brown/tan color of the doped fabric. I'm thinking of tea staining silk and doping the silk onto the wing, fuselage, and tail feathers. I read something on using tea for staining in one of the British magazines. Also, do you have the CL vs Drag curves for the Quabeck 3.5/10 or 3.5/12? I've got the MTB (book) on Quabecks, and the only curves in there are on the 2.5/8 and 2.5/9.

"Out of space and time. Take care, good health, and good lift!" Thank you for your contribution, Mark. A good friend of mine, John Lupperger, has a Fiesta SF which he flies quite frequently. At first, when he was reviewing the model for another magazine, he didn't really care for the way his Fiesta was handling (perhaps your complaint, Mark). It was a strange-handling model in pitch, and it never seemed quite stable at any speed, with a tendency to hunt or oscillate. It wasn't a bad flying model then; it was just not right.

It seems that the Multiplex people designed the Fiesta's stab with a flat bottom airfoil (a lifting profile). It was suggested by this writer and one or two others that John invert the stabs to see if it didn't fly better. Apparently, those of us doing the suggesting agreed that it is not a good idea to have a lifting stabilizer. (Some old timer designs and free flight designs have them because their stabs are so large they actually become a tandem wing!) For gliders, however, the stabilization comes from a down force (a moment) capable of counteracting the negative pitching moment of the airfoil. This moment wants to pitch the nose of the

## HAVE YOU TRIED FULL-SCALE?

AFTER YOU DID ALL THE WORK, WHY LET YOUR AIRPLANE DO ALL THE FLYING?

INFO \$3.00

BUILD & FLY THE miniMAX YOURSELF!



AWARDED SUN-N-FUN 86  
"Most Innovative New Design"

- Computer Designed
- Part 103 Ultralight
- Wood Construction
- 3 Axis Control
- Easy Construction

TEAM INC. BOX 338M. BRADYVILLE, TN 37026 (615) 765-5397

## MAMMOTH SCALE PLANS

CESSNA 180 - 108" Wingspan  
CURTISS P40D - 102" Wingspan  
BERLINGER/JOYCE P-18 - (102.5")  
PAZMANY PL-4 - 105" Wingspan  
F/W FW44J 'Stegiltz' - 89.5" Wingspan  
DOUGLAS A1H 'Skyraider' - (120")  
SHOESTRING - 95" Wingspan  
F8F HELLCAT - 98" Wingspan  
BERLINGER/JOYCE OJ-2 - 102" Span  
EASTBOURNE MONOPLANE - 112"

BOEING F4B2 - 90" Wingspan  
DOUGLAS O25C - 80" Wingspan  
F/W FW56 'Stosser' - 103.5" Wingspan  
WACO/YKS-8 - 99" Wingspan  
RYAN S-C - 112" Wingspan  
T-28B - 102" Wingspan  
STEVENS AKRON - 100" Wingspan  
WATERMAN ARROWBILT - 92" Span  
BEBE JODEL D9 - 102" Wingspan  
DYKE DELTA - 88" Wingspan

Plans are mailed by air; rolled in a heavy-duty tube. P40, T28B, Skyraider, Hellcat, Stevens Akro, OJ-2, Dyke Delta and Eastbourne are \$33.00. All others are \$24.00. Please add \$5.00 for postage and handling. California residents add 7% sales tax. Overseas orders add \$12.00 for air postage. Catalogs: Best of Scale and Two British, \$9.00.

BOB HOLMAN PLANS Box 741-MB, San Bernardino, California 92402 (714) 885-3959

glider down. The higher the pitching moment of the wing's airfoil, in the case of the Fiesta's Wortmann FX60-100, very high, the higher the matching down force at the tail must be. This meant to us that the stab on the stock Fiesta SF was upside down! John was hesitant to experiment with the inverted stab idea and possibly crash the model. The idea of going from the factory's lifting stab to a negative-lifting stab was a bit too radical.

Well, after his product review was over and published, he got a call from Brian Chan who also flies a Fiesta SF. Brian had inverted the stabs and successfully flown the Fiesta. On Brian's recommendation, John decided to give it a try. The resulting transformation of the Fiesta SF was dramatic. The model's flying habits became predictable, stable, and fun, instead of work. Now the Fiesta SF is John's first choice for thermal duration contests. The optional double-blade spoilers are very effective and do not seem to adversely affect the model's pitch stability along its final glide path. Landings are made easily and predictably. Give it a try, Mark, if you haven't already done so.

Trust the British to give the best answers for obtaining that light brown doped fabric color for antique scale gliders! There is probably as much scale activity going on over there as anywhere in the world, so they

should know. Besides, I have no experience in this area and can only conjecture.

As for the Quabeck data on the higher camber sections you mentioned (HQ 3.5/10 and /12), I'll have to say I've never seen any! If anyone out there in the soaring community has data on these sections, please share it.

More recently, Mark sent in the following letter which contains a mini report on some of the teams which participated in this summer's Great Race back in Illinois.

"I hope all is well out your way. It is hot and dry around here! At this rate I'll never bitch about rain again.

"Enclosed are slides from the Great Race. I hope you can use them. The Great Race was on June 11th and 12th, and 18 teams entered. The weather was in the low to mid 90s with the wind varying from 5 to 15 mph (mostly 15 mph). EISS (Eastern Iowa Soaring Society) finished the course in mid-afternoon at 2 hours 14 minutes, which is a new course record. Jack Hiner and the SOAR club (*the host club—wrf*) went out about 3:45 p.m. or so and completed the course in 2 hours 35 minutes.

"Sunday was a bit windier; no one completed the course, though there were a few good flights. We finished 8th overall; our best yet. We need to practice more before the next race.

"Slide 16 is of the SOAR team. Jack Hiner



## CLASSIFIED ADS

**word, with a minimum of \$5.00. No advertising agency discounts allowed. Name and address free, phone number counts as two words, abbreviations count as whole words and will be spelled out. All ads are payable with order, and may be for any consecutive insertion period specified. Send ad payment to: MODEL BUILDER, Classified Ads, 898 W. 16th, Newport Beach, CA 92663.**

**IMPORTANT INSTRUCTIONS: Non-commercial (personal items) rate is 25 cents per word, with a minimum of \$3.00. Commercial rate is 40 cents per**

NOWLEN AERO Peanut Scale Classics: Wright Type A \$695, Nieuport 11, Deperdussin \$10.95, Bristol Scout \$13.95, Aerodrome \$7.95 \$2.00 S & H any size order within U.S., 139 Boardwalk B, Greenbrae, California 94904.

WANTED: RTF u/c Planes from Aurora/K&B, Comet, Cox, Gilbert, Sterling, Testors, Wenmac, etc. Complete or pieces, buy or trade John Fietze, PO Box 593, Lynbrook, New York 11563.

WANTED: Ignition model airplane engines and model race cars made before 1950. Jim Clem, 1201 E. 10, P.O. Box 524, Sand Springs, Oklahoma 74063; (918)245-3649.

SPECIALIZING IN MAJOR DECALS: for fast service and good prices, send \$1.00 for illustrated catalog to: Clark's Aircrafters Supplies, 501 Raintreen, Malvern, Pennsylvania 19355.

FREE FOREDOM CATALOG with this ad. FOREDOM POWER FLEX KIT \$160.65 plus \$5.00 postage. REG \$189. Smith's Hobby Lobby, 2123 Linda Rd., Alexandria, Louisiana 71301; (318)443-6510

WANTED: Ace Pulse Commander Flight pack or complete set to replace stolen set. Also Jetco "Thermic 50" kit or rib patterns. Andrew Pedersen, 346 Brock St., Apt. 404, Kingston, Ontario, Canada K7L 1T2; (613)547-3196.

WANTED: SPARK IGNITION MODEL AIRPLANE engines circa 1930-46. Fair, competitive prices. Tom Forsythe, 318-12th Ave., Box 141, New Glarus, Wisconsin 53574; (608)527-2066.

FOR SALE: If you are a hobbyist like me and always wanted to have your own kit line, this may be just for you. I would like to sell my radio control model airplane manufacturing and design business. I am currently kitting 5 designs and I have finished plans for several more. Included in the sale will be all original mylars, design rights, specifications and parts lists, templates and gigs. In addition to the airplane stuff is a commercial size blueprint machine and flat-bed vacuum frame printer so you can make your own mylars and sets of plans. For price information, write: Buzz Waltz R/C Designs, 403 Industrial Pl., Palm Springs, California 92264, or call (619)325-2141

AERO DIGESTS, AIR CLASSICS, SCALE MODELER, AEROMODELER, BOOKS. Trade for pulps. SASE. Winicki, Box 417, Great River, New York 11739.

CARBON FIBER: sheets, rods, angles, mat, tailboom. Other Free Flight supplies. Send SASE to: Bradley Model Products, 1337 Pine Sap Ct., Orlando, Florida 32825.

WWI AND WWII POSTERS. In color, imported from England, 20 x 30, suitable for framing. Sample photos, send \$1.00 to Biggin Hill Publ., Box 786-O, Freeport, New York 11520.

PLANS ENLARGED: Large Scale Specialists, Model Drafting Software, PC Model Software. Free catalog. Concept Technology, P.O. Box 669D, Poway, California 92064; (619)486-2464.

CAPACITIVE DISCHARGE IGNITION KIT—coils, spark plugs. Send SASE for details. Fuji-Max USA, 2747 N. Giddings, Visalia, California 93291.

MAGAZINES FOR SALE: *Model Builder*, *MAN*, *Air Trails*, *Flying Models*, *Skyways*, *Air Age*, *Air News* and more. Many back to the 1930s and 1940s. Excellent to mint condition. Send SASE for list of titles and any inquiries to: Mrs. Carolyn Gierke, 1276 Ransom Road, Lancaster, New York 14086.

AERO CLUB OF ISRAEL modeling flying needs your support. Send SASE for newsletter and information. New Friends of the Aero Club of Israel, 79-02B 212 Street, Bayside, New York 11364.

ANTIQUÉ MODEL IGNITION PARTS CATALOG: GHQ, DeLong, O.K. McCoy, others. Timers, needle valves, tanks, cylinders, operating instructions, kits. Catalog 1988, 1,000 Parts, \$5.00 pp. Foreign \$9.00. Chris Roszbach, R.D. 1 Queensboro Manor, Box 390, Gloversville, New York 12078.

4" x 8" VACUUM FORMER with self-contained heat source. Easily constructed from local materials. Plans, \$12.00. Complete unit, \$42.00 postpaid. GRACO MODELS, Box 18358, Kearns, Utah 84118.

IGNITION AND GLOW ENGINES. Collectors, runners, used, new. Sell, trade, buy. SASE for large list. R.L. Eierman, 504 Las Posas, Ridgecrest, California 93555; (619)375-5537.

REDUCING INVENTORY of engines, kits, and model supplies originally purchased "to build after retirement"! Find I will have to live until age 101 to complete them. Send large SASE for multi-page Sale List. Robert Hawkins, 1200 E. Calle De La Cabra, Tucson, Arizona 85718.

MODEL MOTORS NEW AND USED. ALSO PARTS, ACCESSORIES, KITS. Complete list, \$1.00 T. Crouss, 100 Smyrna St., West Springfield, Massachusetts 01089.

Bill Hannan's PEANUTS & PISTACHIOS, Volume 3: Plans, photos, and pointers. FUN! \$5.00. Volume 2 still available at \$4.95. Postage and handling \$1.50 (one or two books). California orders: add applicable sales tax. HANNAN'S RUNWAY, Box A, Escondido, California 92025.

NEW! Latest catalog of books, plans, rubber and goodies, \$2. HANNAN'S RUNWAY, Box A, Escondido, California 92025.

CUSTOM EMBROIDERED PATCHES. Your design, made any size, shape, colors. Five-patch minimum, guaranteed colorfast. Free brochure. Hein Specialties, Inc., Dept. 238, 4202 North Drake, Chicago, Illinois 60618-1113.

STRIPPED GLOW PLUG THREADS RE-PAIRED with stainless steel Heli-coils. 2-stroke heads \$7.50. 4-stroke heads \$10.00 postpaid. Send head only. C.F. Lee Mfg. Co., 7215 Foothill Blvd., Tujunga, California 91042.

ROHACELL® STRUCTURAL FOAM. Light, strong, ideal for use with fiberglass, carbon or kevlar. Compatible with most adhesives and finishes. Send SASE to: Composite Structures Technologies, Dept. D, Suite 268, 3701 Inglewood Ave., Redondo Beach, California 90278-1110

OLDTIMERS: Built by Dale Myers. Electric R/C flying. All-transparent covered. Super Buc — Scram 83" — Kerswap — Pacer C — King Burg — Pacific Ace — Strate Streak 66" — Berkley Currier Sportster — Record Hound — Trenton Terror. Models cannot be shipped. Dale Myers RD #3 Stewartstown, Pennsylvania 17363, (717) 993-6246.

RANDOLPH nitrate and butyrate dope. Klotz lubricants. Golden Age control line kits and plans. Send large 45¢ SASE for full details. ABC Hobby Supplies, Box 2391, Clarksville, Indiana 47131.

WANTED: Berkeley and Cleveland kits or related items: parts, plans, boxes, brochures, books, ads, radio equipment, accessories, etc. Gordon Blume, 4649-191st Ave. S.E., Issaquah, Washington 98027.

FREE \$4.95 SURPRISE GIFT WITH ANY MERCHANTISE PURCHASE! JEWELRY, PATCHES REPLICAS: Own the very first wings, embroidered Royal Flying Corp. 3½ inches, \$4.95. Hat-In-The-Ring pin \$4.95. The renoun Blue Max: blue cloisonne Maltese Cross, gold plated eagles, 2 inch medal, free chain, \$12.95. Shipping \$2.00. WWI to present catalog \$1.00 refundable. Company Of Eagles, 875A Island Drive, Suite 322M, Alameda, California 94501-0425.

WANTED: Ignition model engines and race cars, 30s and 40s vintage. Don Blackburn, P.O. Box 15143, Amarillo, TX 79109; 806-622-1657.

SCALE DOCUMENTATION: PLAN ENLARGING. Photo packs, three views, drawings for 1600 aircraft. Super Scale R/C plans for Giant, Sport. 60-page catalog \$4.00. Scale Plans and Photo Service, 3209 Madison Ave., Greensboro, North Carolina 27403; (919) 292-5239.

"The GOON" is here! Most accurate 1930s Racers, etc., by Vern Clements, 308 Palo Alto Dr., Caldwell, Idaho 83605. NEW big Plans CATALOG with "NEWS," \$3.00.

FREE sample of the OKIE FREE FLIGHT FLYER for a 25 cent uncanceled unlicked stamp. Bill Baker, P.O. Box 249, Norman, Oklahoma 73070-0249.

was the team pilot. The model is 149 inches in span, 10 square feet in area, the airfoil is the famed Selig 4061, and the fuselage is based on a Dale Folkening design. Bob Sealy's Constellation X-C ship had its fuselage mold pulled from this Folkening fuselage plug. (They are identical.—wrf)

"Slide 17 is a photo of Susie Lipp of team BOSS. The modified Sagitta XC she is standing next to is very good! Team BOSS finished about fifth or so. Susie is the new LSF Treasurer. It is great to see women at the field flying and not just watching. She's a super person!

"Photo 21 is a picture of the moment of launch for team EISS. The model is being flown by Rusty Shaw who is the model's designer as well. It spans 14 feet, has about 1400 square feet of wing area, uses the Epler 374 airfoil with flaps, and weighs 11

Ace Radio Control . . . . .	68
Aerodyne Ind. . . . .	107
Airtronics, Inc. . . . .	Cover 2
American Jr. Aircraft Co. . . . .	93
American Sailplane . . . . .	80
Associated Electrics . . . . .	77
Astro Flight Inc. . . . .	63
B & D Model Products . . . . .	101
B & P Associates . . . . .	94
Beemer R/C West Dist. Inc. . . . .	107
Byron Originals . . . . .	5
Campbell's Custom Kits . . . . .	75
Cannon Electronics . . . . .	80
Carl Goldberg Models . . . . .	89
Circus Hobbies . . . . .	67
Conley Precision Engines, Inc. . . . .	69
Coverite . . . . .	98
Culpepper Models Inc. . . . .	98
Cygnat Software . . . . .	96
Davey Systems Corp. . . . .	73
Dick Hanson Models . . . . .	102
Doylejet . . . . .	81
Du-Bro Products . . . . .	66
Electronic Model Systems . . . . .	102
F.A.I. Model Supply . . . . .	86
Fabtronics . . . . .	90
Flying T. Model Co. . . . .	100
Flyline Models, Inc. . . . .	75
Fourmost Products . . . . .	70
Fox Manufacturing Co. . . . .	93
Futaba Industries . . . . .	87, Cover 3
G.M. Precision Products . . . . .	74
Great Planes Manufacturing . . . . .	95

INDEX TO ADVERTISERS

Hayes Products . . . . .	74
High Sky . . . . .	75
Historic Aviation . . . . .	1
Hobbico . . . . .	91
Hobby Horn . . . . .	68
Hobby Technics . . . . .	98
International Modelers Show . . . . .	84
Indoor Model Supply . . . . .	79
J'Tec . . . . .	97
Jed's Shade Canopies . . . . .	99
Jim Walston Retrieval Systems . . . . .	80
JM Lupperger Plans . . . . .	75
Joe's Hobby Centers . . . . .	76
John Pond O/T Plans . . . . .	97
Jomar Products . . . . .	90
Kavan . . . . .	72
K & B Manufacturing . . . . .	76
K & S Engineering . . . . .	88
K & W Enterprises . . . . .	98
Mammoth Scale Plans . . . . .	103
McDaniel R/C, Inc. . . . .	79
Midway Model Company . . . . .	92
Millcott Corporation . . . . .	92
Model Builder Binders . . . . .	107
Model Rectifier Corporation . . . . .	Cover 4
N.F. Video Library . . . . .	86

North West Hobby Supplies . . . . .	64
Northwest Expo 88 . . . . .	96
P.A.W. Diesels . . . . .	107
Pacer Tech (ZAP) . . . . .	86
Paper Airplanes International . . . . .	90
Paper Models International . . . . .	81
Peck Polymers . . . . .	80
Pierce Aero Co. . . . .	83
R/C Buyers Guide . . . . .	108
Rahm's Winches & Retrievers . . . . .	81
Robart Manufacturing . . . . .	94
Satellite City . . . . .	82
Sermos R/C Snap Connector . . . . .	81
Sheldon's Hobbies . . . . .	99
Sid Morgan Vintage Plans . . . . .	86
Sig Manufacturing Co. Inc. . . . .	4
Su-Pr-Line Products . . . . .	100
T & D Fiberglass . . . . .	96
Team, Inc. . . . .	103
Technopower II, Inc. . . . .	85
Teleflite Corporation . . . . .	101
Thorpe Engr. (Star Hawk) . . . . .	65
Tom Dixon . . . . .	101
Top Flite Models, Inc. . . . .	84
Vinylwrite Custom Lettering . . . . .	83
VL Products . . . . .	76
Walt Mooney Peanuts . . . . .	76
Williams Bros. . . . .	70
Wilshire Model Center . . . . .	90
Windsor Propeller Co. . . . .	78
World Engines . . . . .	3
Yellow Aircraft & Hobby Supply . . . . .	88
Zenith Aviation Books . . . . .	71

pounds.

"Rusty Shaw designed the Chuperosa RCHLG which appeared in RCM earlier this year. (See above too!—wrf) Rusty is a very good pilot!

"Question: Why is the E374 so good? To look at the curves it doesn't look all that special (peak CL, etc.), but it seems to kick butt. Wurtz, Jolly, Shaw, etc., have proven it. I realize they are excellent pilots, but still. Time for me to go." Thanks for your second contribution, Mark! The Eppler 374 data as presented in the Eppler book MTB 1/2 (available through Wilshire Model Center, see ad) may not be accurate. I suspect its lowest point on the "drag bucket" is much lower than shown. The difference in top speed between models using the E374 and those of near equal size (etc.) of different wing profiles is dramatic. Also, the fact that these models climb 85 to 95 percent as good as those with (for example) E205-type sections bears out the lift coefficient similarities. Hopefully, this summer's wind tunnel experiments by Selig and Donovan at Princeton University will shed some light on the subject. (See below.)

**WIND TUNNEL EXPERIMENTS AT PRINCETON**

Speaking of airfoil data, as most of the really involved sailplaners in this hobby are aware, Michael Selig of (obviously) Selig airfoil fame and John Donovan his partner in research, have been doing a historic and monumental amount of experimental work using the low-speed (i.e., low Reynolds number) wind tunnel at Princeton University this summer. The preliminary work of raising money for obtaining the best 12-bit analog/digital test equipment and related miniature sensors and probes to replace the aging equipment at the tunnel, and of obtaining test wing panels ("models") for the actual testing took longer than anticipated (an extra year), but the delay has been well worth it! The data being generated is truly

the most accurate yet obtained anywhere in the world, and it undoubtedly will have significant effects on high-performance model sailplane design in the near future.

Dramatic performance improvements have been achieved by Selig and Donovan with 15 new airfoils designed by a \$30,000 to \$40,000 computer program developed at Boeing and donated to the research effort. This program takes something in the area of 18 hours of computer time (!!!) to generate the predicted performance polars for one new airfoil. Testing these newly designed airfoils in the wind tunnel has proven that the computer program does indeed accurately predict the behavior of the section in the real world, much more closely than the less sophisticated Eppler/Sommers program. This means that these new airfoils are approaching what I believe are going to be the ultimate super-sections for our purposes. Michael says they are much better than anything we've been flying to date. Exciting stuff, eh?

The wind tunnel is, according to Michael, a very sensitive instrument for recording data. In fact, it is so sensitive that they cannot run the low speed tests during daylight hours. Apparently, wind, temperature, thermals, or any other such outside sources of atmospheric turbulence, cannot be totally straightened and smoothed as they pass through the wind tunnel's screens, vanes, and chambers (see illustration). This makes the low speed airflow in the tunnel a little erratic, and makes the data obtained somewhat unreliable. Low speed tests have therefore been run only at night by Michael when the air outside is calm, while the high speed tests are run during the day by John where the effects of slight amounts of turbulence are negligible.

So far (mid-August) 45 airfoils have been tested! Twenty or thirty more are scheduled. John will remain at Princeton for the testing through the first of November with Michael

having to return to Penn State for the upcoming semester (I believe he is now a professor). Michael will be periodically returning to the tunnel to complete the work with John during the fall. In the meantime, anyone wishing to contribute their time to this historic effort is urged to contact Michael or John at Princeton (609)452-5379 and volunteer. Model makers are needed for some fast-turnaround wing panel making for the purpose of testing one last batch of new sections. The panels are relatively small and easy to make, give John a call today for details. Panel dimensions are shown with this article.

About a year ago I received from Jerry Krainock a bunch of photographs which he took of one of these test "models," and a letter. It's all pretty self-explanatory, so I'll let Big Jerr do the talking.

"These are pictures of the wind tunnel model fabricated by Mike Bame for Michael Selig's project.

"The model is approximately 12 X 32 inches and is of the MB 253515 profile. (This is the section which is very similar to that of the Pierce Aero Co. Gemini MTS kit glider, and the section used by Alex Bower on his 1983 F3B World Champs glider.—wrf) It is made of blue foam and fiberglass which has been vacuum-bagged.

"It is Bame's usual standard of construction, which is to say, excellent. The trailing edge is very straight and so sharp that one must be extremely careful in handling it.

"When I took this picture, there was one coat of primer still to go on, but the model has since been completed and sent to Mr. Selig.

"We look forward to Mr. Selig's results." Thanks, Jerr, for the contribution. We are all looking forward to the results!

**TIME TO FLY**

That's all we have room for this time. Again, I apologize for missing last month's issue. Hopefully, this month's larger col-

NOTICE: New Full-Size Plans prices are now in effect. Send a reply with address stamped envelope for your list of revised plan prices.

# MODEL BUILDER

All Full-Size plans purchased from MODEL BUILDER Magazine include a reprint of the construction article, if building instructions were part of the article.

SEND TO: MODEL BUILDER PLANS SERVICE  
898 W. 16th St., Newport Beach, CA 92663  
Minimum order: \$10.00

- No. 11881 THE WHISP \$10.00  
Simple R/C hand launch glider for slope or park flying. 49-inch span. By J. Tank.
- No. 11881-OT CLASS C GLIDER \$7.50  
A Joe Weathers classic glider design from Flying Aces, 1939. Wingspan is 30 inches.
- No. 10881 HAWKER HURRICANE \$17.00  
A control line sport scale for .30 to .40 engines, made of cardboard! C. Felton
- No. 1088-OT PORTERFIELD \$7.50  
Rubber scale monoplane from 1940 Flying Aces. 28-inch span. C. McCullough.
- No. 9881 BLACK STAR \$10.00  
A swept-wing, Vee-tailed R/C model for an .049. Uses foam wings. By Saponara.
- No. 9882 CONSOLIDATED XBY-1 \$7.50  
A rubber-powered bomber in 1/20 scale with a 27-inch span. By Mark Fineman.
- No. 1073-OT GOLDBERG ZIPPER \$10.00  
Most famous of all OT gas models, ended cabin era. Redrawn by Phil Bernhardt.
- No. 8881 MEYERS OTW-160 \$10.00  
A sport-scale replica of a classic biplane for .45 power. 50-3/4" span. Rohrback.

### NEW ORDERING INSTRUCTIONS

U.S. orders, including APO and FPO, add 20% of total order for shipping and handling. Overseas orders (includes Canada and Mexico) add 50% of total order. Remit payment by International Money Order or U.S. funds, drawn on U.S. bank. Please, no cash or C.O.D.'s. Mastercard or Visa include card number, expiration date, and signature. Add 5% to credit card orders. California residents add 6% sales tax.

umn will make up for it!  
Thermals to all, Bill Forrey, 3610 Amberwood Ct., Lake Elsinore, CA 92330, (714) 245-1702.

Jake. . . . . Continued from page 7

Dear Virgil:  
I suspect it would be capable of cutting not only your grass, but your car's radio antenna, your wife's clothesline, your neighbor's volleyball net, and your community's cable TV link.

Jake

Dear Jake:  
I love your column and have learned a lot from it, but I have a big problem. Every time I start reading, the bottom of the page says to turn to some other page. Well, I keep getting lost trying to find that other page, and I've never been able to read the end of your

column. So would you please put the end first?

Gary in Huntington Beach, California  
Dear Gary:

Please turn to the top of page 173 for your answer.

Jake

\* \* \*

Dear Jake:  
If I took the fuselage and fin from a Pitcairn Mailwing and put the wing and tail from a Buhl Pup on it, would I be correct in calling it a Pit Buhl?

Hybrid in Hialeah, Florida

Dear Hybrid:  
Pitcairn Pup sounds better, and you won't have to register it with the police department.

Jake

\* \* \*

Dear Jake:  
What's all this about laminar flow? What is it? Where can I get some if it's good for my airplane?

I'll Try Anything in Forest Park, Illinois

Dear I'll Try Anything:  
Laminar flow is not difficult to explain. You have a kitchen counter, right? It probably has some kind of formica skin laminated onto the counter top. If this formica laminate cracks or gets cut, then water can seep below it and dissolve the glue and warp the underlying wood. This water seepage below a formica laminate counter top is what's known as laminar flow. It would be useful for your airplane only if you plan to slice tomatoes on it.

Jake

\* \* \*

Dear Jake:  
I think I saw you at Toledo this year. Were you piloting one of the model blimps that were flying around inside the arena?

Harvey in Holland, Michigan

Dear Harvey:  
No, but I did provide the hot air for one of the radio-controlled balloons.

\* \* \*

Dear Jake:  
Pattern airplane design seems to have fallen into a rut. They all pretty much look the same. When FAI turnaround events came along a few years back, the designs changed a little bit. Some got bigger, a few tail draggers showed up, and there was a sprinkling of semi-scale offerings. But since then the old stagnancy has set in, and all the Summits, Challenges, Illusions, etc. look like they all fell off the same truck.

Whatever happened to the good old days when low wings, high wings, shoulder wings, and even biplanes could be found together in the pit area at a contest? How's a judge today gonna tell my airplane from the next guy's? The only way to get attention now is to have a shaplier assistant with less clothes on her than the next guy's. Phooey on uniformity! Bring back variety!

On The Soap Box in Teaneck, New Jersey  
Dear On The Soap Box:

Researchers have been trying for decades to determine exactly when "the good old days" took place. Recently, scientists at the Colt's Neck Biosynchronous Chronological Observatory in Delaware though they had

located the good old days between February 23, 1954 and October 8, 1958. Discovery of an erroneously placed decimal point, however, negated their findings and restored the uncertainty boundary on the gold old days to its original range of 1,000,000 B.C. to yesterday. In terms of model aviation, it's probably safe to say that the good old days occurred somewhere between the birth of the Wright Brothers and the advent of fiberglass.

Jake

\* \* \*

Dear Jake:  
Tootles, my pet canary, is blind. In order to give him some exercise and to relieve some of my more bizarre compulsions, we have been experimenting with radio-controlled flight (not on me, but the bird). By using ultralight equipment, I have achieved moderate success. The procedure was not too difficult, as only pitch control was needed. Canaries, you see, tend to fly in circles anyway. Lack of directional control has only been a problem when attempting avoidance maneuvers in the vicinity of tall linear objects (like telephone poles).

My problem, and this is where I need your help, comes from flight control during stunt maneuvers. Tootles has a peculiar habit of freaking as he comes over the top of a loop or whenever I try to fly him inverted. I have tried experimenting with Darvon and nitrous oxide, but flight duration and velocity suffer. Also, disorientation develops with most forms of mind-altering chemicals (me, not the bird).

It is my opinion that when Tootles is properly trimmed, and when my squadron of similar but more aggressive sightless canaries are recruited and properly equipped, they will be of an invaluable service in eliminating the wolverine and badger problems that you developed when your club tried to rid your field of gophers. (Boy, were you dumb.)

Bentnecker in Martinez, California

Dear Bentnecker:  
We solved our badger and wolverine problems. If you have anything that will work on crocodiles, please let me know.

Jake

### Workbench. . . . Continued from page 7

B.O.M. only applies to competition model aircraft being used in contests. It does not apply to sport flying, and the more there are of sport control line and free flight models being made available to the non-modeler and/or the no-time-to-build-modeler, the better.

Other than the above-mentioned exceptions, the B.O.M. rule in AMA-sanctioned contests should remain in effect. The grownups with fat wallets should not be allowed to turn the hobby into a bank account competition, and the young and/or inexperienced modelers should not be intimidated out of the hobby by those who are lucky enough to have otherwise well-intended expert help. Like any other unenforceable rule, it should not be dropped simply because it is difficult to control. The

rule does its job as a deterrent, keeps the honest modelers in line, and in the final analysis, those who break the rule really become the losers.

#### CANARD MODELER FOUND

The solution to the origin of the "Mystery Canard" in our August issue has been solved by none other than the designer himself, Bob Knutson, of Austin, Minnesota. The model was a refinement of a 1941 original design, powered by an Ohlson .23, which had some stability problems. The refined version, built in early 1942 (hmmmm, does that mean not O/T legal?), used a Goldberg Zipper wing for the canard, a Goldberg Sailplane main wing (stretched in span by adding 15 inches to the center panel), sub-rudders at the main wing dihedral joints, a retractable main wheel, and powered by a Super Cyke. This model made several dozen flights and showed excellent power and glide characteristics. The final mods were made in 1946 after Bob spent three years in the Air Force. He removed the forward rudder and added two rear rudders above the main wing winglet tips. He still has the Super Cyke, and is thinking about replicating the last version of the canard for old timer flying.

We received two answers on this one... the other coming from Joe Flavin, of Bendersville, Pennsylvania, who used to fly the competition circuit with Bob. However, Bob had the earliest answer and so wins the one-year subscription. By the way, we're not trying to step on Bob Stalick's *Mystery Model* series with these puzzlers, they just happened to come along.

#### HISTORICAL AVIATION ALBUM

We're happy to announce that the excellent scale view drawings by the late Paul Matt are again available, from the new owners, SunShine House, Inc., P.O. Box 2065, Terre Haute, Indiana 47802, phone (812) 232-3076. The complete listing of more than 120 aircraft subjects, mostly from the Golden Era of aviation, with some WWII aircraft, is available by sending a S.A.S.E. to the above address. Most of the subjects are covered on two sheets, which cost \$7.00 per set, plus postage and handling. Others taking more sheets only cost a little more.

SunShine will also be reintroducing many of the Paul Matt Historical Aviation Album features in the form of a Best of Paul Matt series. The first of this series, *AERONCA - The Best of Paul Matt* is now available. This 88-page soft cover book contains 14 pages of Paul Matt's drawings, along with reprints of stories by Paul Matt gathered from Volumes 3, 10, and 15 of his original Albums, plus more than 160 photos. Contact SunShine about the Paul Matt series, as well as their own Aviation Heritage Library listings.

#### AIR MAIL

Neil Greene, of Granville, Ohio, is one of many who have written to us in praise of Bill Warner's "Hey Kid" series, so well illustrated by Jim Kaman. A book on the series has been discussed but not finalized. In the meantime, all of the back issues, from November '87 when it began, up to the present, are still available. The last of the series is to be in the December '88 issue, on building the Peck-Polymers Fike Peanut. At

## P.A.W. DIESELS

·049 TO ·35, RC & STD

PERSONAL & FRIENDLY SERVICE

SEND \$1 FOR LISTS & USEFUL DIESEL INFO.

ERIC GLUTTON,  
913 CEDAR LANE,  
TULLAHOMA, TN. 37388

DAVIES-CHARLTON DIESELS!  
NEW PRODUCTION!

DART	.03	EXCELLENT
MERLIN	.045	QUALITY.
SPITFIRE	.06	ENGLISH
SABRE	.09	MADE.

#### MULTIPLEX MODELTECHNIK

GmbH of West Germany offers to you:

- True narrow-band conversion technology
- The finest equipment
- Competitively priced
- Beemer-Multiplex VIP Service (The best)
- Full stock of accessories and parts

Send \$5.00 for new catalog in English or call us: (602) 483-9577

BEEMER R/C WEST DISTRIBUTORS INC.  
7725 E. Redfield Rd., Suite 102  
Scottsdale, Arizona 85260

## MODELS

F-84  
F-86  
F-100  
F-104

Mig 15 and 5 more  
all 1/72 scale

10 Model Kits  
\$14.95



Send \$14.95 plus \$3.50 shipping & handling  
to **Aerodyne Industries**  
... Airplane offer...  
P.O. Box 2267  
Orcutt, CA 93455  
allow 6-8 weeks delivery ... sorry ... no COD's

this time, there are no plans to extend the series. Our original intention was to get totally beginning modelers off to a good start by giving them the most elementary of basics in model building and flying. When you go beyond that, the number of directions that can be taken are mind-boggling: indoor paper and microfilm; outdoor rubber and gas (and electric) scale; outdoor duration rubber, gas, and glider; Old Timer rubber and gas... there are so many specialties. However, every one of those specialties requires the basic knowledge gained from reading and acting out (partic-

## COVERUP!

Sturdy, high quality, rich dark green vinyl-covered binders for your valued copies of *MODEL BUILDER* Magazine. Gold lettering on spine and front cover.



One Binder . . . . . \$6.95  
Three Binders . . . . . \$17.95  
Five Binders . . . . . \$27.95  
(For more than 5, include \$5.00 for each additional binder.)

Shipping: Binders shipped in U.S. by UPS only. For one binder, add \$2.25. For each additional binder add 75¢. For binders shipped outside U.S., add \$4.00 for one binder. For each additional binder, add \$1.50. For Air Mail rates overseas, please inquire.

PLEASE... All payments must be in U.S. funds, drawn on a U.S. Bank.

California residents add 6% Sales Tax

## MODEL BUILDER

898 W. 16th Street  
Newport Beach, CA 92663

ularly the latter) the instructions in the "Hey Kid" series and gaining firsthand experience. When all of this becomes second nature, it's amazing how much more understandable, and interesting, some of the more complicated appearing categories become.

\* \* \*

Norm Rosenstock, 124 Granada St., Royal Palm Beach, Florida 33411, phone (407)798-5154, is attempting to record for modeling history the story of Harold Goldclank, the famed "Court Jester" of radio control modeling in the 1950's, '60's, and '70's. "Goldie" was a natural comedian whose voice and delivery was a combination of actor/comedian Phil Foster and a fog horn. He was a member of an elite group of New York City area modelers who called

# SUBSCRIBE NOW AND SAVE!

## FEATURING:

Construction Articles  
Product Reviews  
Radio Control  
Peanut Plans  
Electric Flight  
Old Timers



**Yes, start my subscription  
to Model Builder!**

 New

 Renewal

Name \_\_\_\_\_

Address \_\_\_\_\_

City \_\_\_\_\_

State \_\_\_\_\_ Zip \_\_\_\_\_

\$25.00 for one year (12 issues). Over  
\$10.00 off newsstand prices.

\$47.00 for two years (24 issues). Over  
\$23.00 off newsstand prices.

M/C or Visa # (Add 5%) \_\_\_\_\_

Expiration Date \_\_\_\_\_

Signature \_\_\_\_\_

\$38.00 for one year (includes postage),  
outside U.S. including Mexico and Canada.

For two years (24 issues) send \$68.00.

ALL PAYMENTS MUST BE IN U.S. FUNDS

DRAWN ON A U.S. BANK  
**MODEL BUILDER**

898 W. 16th St., Newport Beach, CA 92663



# MODEL BUILDER

WORLD'S MOST COMPLETE  
MODEL AIRCRAFT PUBLICATION

themselves "The S.O.B.'s," and if you never heard of them, you've probably made the wrong assumption about the last initial... it stood for "Brooklyn!" Norm is gathering as much material as possible, mostly in the form of "Goldie" anecdotes, but is in dire need of some good photographs of our late buddy. If you think you may have some salted away in your collection, dig around and see what you can find.

\* \* \*

Retired airline pilot/modeler A.P. "Speed" Wilson writes in to chide those of us who still think about aerodynamics once in a while, and allow ourselves to cause misconceptions by abbreviating our references to certain terms. I have a certain favorite gripe in this area too, but first we'll take Speed's. His concern is about the use of the word "moment" when talking about the distance to the nose or tail of an airplane from its balance point. Actually the moment is a force times a distance. That distance is more correctly referred to as the "moment arm." When the nose weight times the nose moment arm equals the down force on the stabilizer times the tail moment arm, the plane is in balance, and at least as far as those forces are concerned, will fly straight and level. So, a "moment arm" is a distance, in feet, inches, meters, etc. A "force" or weight is in pounds, ounces, grams, kilos, etc. Obviously, then, a "moment" (other than a brief period of time) becomes a measurement of force multiplied by an arm, or foot/pounds,

inch/ounces, etc. This moment, unless counterbalanced by an equal and opposite moment, will start moving whatever mass is out there in a rotational orbit around the pivot or balance point. The classic example is Oliver Hardy at 250 pounds on one end of a seesaw, and Stan Laurel at 150 pounds on the other end. To keep Ollie and Stanley on an even keel, the seesaw must be offset so Ollie is six feet from the pivot at one end, and Stanley is ten feet from the pivot at the other end; i.e.,  $250 \times 6$  equals  $150 \times 10$ , get it?

Now to our gripe... it's CG, or Center of Gravity vs Balance Point. I can almost guarantee you that most any model airplane construction plan you look at will show a CG. I'll also guarantee you that most any time you see it, it's NOT the CG, it's the Balance Point! The Balance Point is a two-dimensional thing, and is really what you are looking for... the point where you can place your fingers on the underside of the wing, on each side of the fuselage, and hopefully, the model will sit with the fuselage centerline parallel to the ground (unless you're standing on a street in San Francisco).

Actually when you have the Balance Point, the CG is probably not far away. In fact, if you draw a vertical line on the plan through the...er... Balance Point and perpendicular to the fuselage centerline, it will probably pass through the actual CG. If your plan has a front view, and you draw a vertical line down through the center of the front view, it will also go through the CG.

Are you beginning to get the idea? Put it this way: If you put an imaginary steel rod into the airplane so its pointed tip was right on the CG, you could put the airplane in any attitude whatsoever and it would just sit there, fat, dumb, and happy, and not try to fall or rotate in any direction. Your imaginary pointer is on the "three-dimensional balance point" of that model! In the side view, the CG is on that vertical line. In the front view, the CG is on that vertical centerline. But where on that line? Where the hell is that elusive CG?

To find the CG, you have to establish one more line, and you'll need the model itself to find it. Try hanging the model somewhere along its centerline, but not at the balance point... from the center of the landing gear, or from a bridle tied across the front or rear wing hold-down dowel. Now dangle a piece of weighted black thread along the side of the fuselage, holding it so it is a continuation of the line that the model is hanging from. In effect, the thread traces the path through the fuselage of the line from which the model is hanging. Note the points on the fuselage that the line crosses, and transfer them to the side view on the plan. Draw a line through these points. It will cross the vertical line you have already drawn through the balance point. Voila! Where it crosses is the CG as seen in the side view! You may not need it for anything, but isn't it nice to know where it is? Actually, this information and a dollar, will probably get you a cup of coffee most anyplace in town!

# FOUR BY FOUR.



## THE ATTACK 4NBL

Our newest 4 channel system has something for everyone. In fact, the Attack 4NBL is such a versatile performer we've customized it for all kinds of radio control fun.

## ATTACK ELECTRIC

The 4NBL/MCR system is destined to become a favorite with electric flyers. This Attack system comes complete with our new MCR-4A integrated receiver/speed control. This remarkable device incorporated a four channel

receiver and a MOSFET speed control into one very compact, very light and very efficient package. It also incorporates BEC to eliminate the need for, and extra weight of, a receiver battery.

## SILENT ATTACK

There's a 4NBL system for sailplane flyers, too. With the Attack glider package you get a pair of S133 servos, R114H four channel receiver and a 250mAh NiCd pack. Again, when size and weight of the airborne package is critical, Attack is the answer.

Transmitter/T4NBL				
RECEIVER	SERVOs	BATTERY	FREQUENCY	TYPE
MCR-4A	S133(2)	BEC	72MHz	Electrics
R114H	S133(2)	NR-4K	72MHz	Sailplanes
R114H	S148(3)	Dry Case	72MHz	Aircraft
R114H	S148(3)	Dry Case	75MHz	Truck/Boat

## ARF ATTACK

Looking for the perfect system for ARF and conventional sport aircraft? Once again, it's Attack to the rescue with a high value package including R114H receiver and three S148 servos.

## 4X4 ATTACK

There's even a surface Attack 4NBL system on 75MHz. Supplied with three S148 servos and R114H receiver, this ground and sea outfit has



The ergonomically designed T4NBL transmitter features comfort contoured case and adjustable length control sticks.

what it takes for gearbox-equipped 4x4's and RC boats.

No matter which 4NBL system you choose, you'll also get our new four channel Attack transmitter.

Loaded with extras like adjustable stick gimbals, servo reverse switches and a rechargeable NiCd pack, the T4NBL transmitter also features a comfort contoured case and neck-strap for fatigue free operation.



Hooked up with a pair of S133 micro servos, this system is perfect for electrics like our Hirobo/Futaba Professor.



The MCR-4A four channel receiver/MOSFET speed control weighs just 1.5 oz. and can easily handle 280 to 540 size electric motors. 1.24" x 2.92" x 0.63"

# Futaba.

Futaba Corporation of America  
555 West Victoria Street, Compton, CA 90220

# Enter MRC-TAMIYA'S RUN-FOR-FUN-NATIONALS \$100,000 IN PRIZES

**PRIZES INCLUDE  
2 PONTIAC FIREBIRDS**



**PLUS \$15,000 SHOPPING SPREE  
AT YOUR FAVORITE  
HOBBY SHOP**

## WIN!



### FIRST PLACE

First Place Finishers in 2 of our 3 events will win a Full-Size Pontiac Firebird valued at \$15,000.

First Place in our 3rd event can win up to \$15,000 in a 10 Minute MRC-Tamiya Hobby Shopping Spree.\*

**Anyone with an MRC-TAMIYA Off-Road Buggy is eligible, and you can win... even if you've never raced before**

As the creators of radio control off-road, we've seen it grow from modest hobby to national sport. From thousands of drivers to millions of hobbyists. Now we're adding still more excitement with our first Run-For-Fun-Nationals.

Our race rules are such that it doesn't matter whether you've raced before. So far, 35% of our entrants have never competed. If you're in that category, come to the track and ask for the "On-Site Public Relations Director". He's there to bring all participants up to speed in a hurry. He'll walk you through entry procedures and help you with the details and any tech problems you may have.

And with our "Random Winner Drawings", even those who finish last in a race have a chance to win.

### WHO CAN ENTER THE MRC-TAMIYA NATIONALS AND WHAT TYPE OF EVENTS WILL THERE BE?

Anyone with a stock Tamiya buggy can enter.† No souped-up or modified buggies. No experience necessary. There'll be a speed competition in 4WD and 2WD. And, a monster truck "carry the egg race" category.

### HOW TO ENTER THE MRC-TAMIYA RUN-FOR-FUN-NATIONALS

The country will be divided into seven regions. The local events will be run by local hobby shops. Local winners will move up to the regionals. Regional winners to the nationals.

**ATTENTION DEALERS:** If you want to know how you can qualify to host one of the regional or local events, give us your name, shop name and address, and location of your local track.

**HOBBYISTS ATTENTION:** To enter the MRC-Tamiya Run-For-Fun-Nationals, see your hobby dealer for an entry form. If he can't help you, write us. Include your dealer's name and address.

### Trophies and Other Prizes Will Also Be Awarded

†See rules for exact qualifications and exclusions at your hobby shop or write to MRC.

## WIN!

### SECOND PLACE

The Second Place Finishers in each of our events can win up to \$7,000 in a 5 Minute MRC-Tamiya Hobby Shopping Spree.\*



## WIN!

### THIRD PLACE

The Third Place Finishers in each of our 3 events can win up to \$3,000 in a Three Minute MRC-Tamiya Hobby Shopping Spree.\*



\* All the MRC-Tamiya products, up to \$15,000 in retail value, you can carry out of a specially stocked hobby shop.



Model Rectifier Corporation  
2500 Woodbridge Avenue  
Edison, NJ 08817