

# A8

## 2006 Audi A8 L W12 quattro Product Information



European Model shown

**2006 Audi A8 L W12 quattro**  
**History of the 12-cylinder engine**



**1931**



Paris Autosalon, Horch 670, a V12 convertible with 6 liter displacement and 120 hp with 3200 rpm.

**1938**

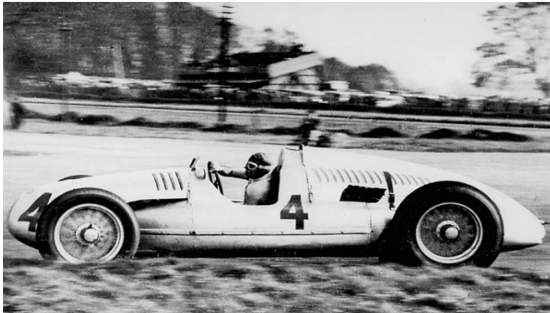

Auto Union "Type D" race car, a 12-cylinder with 485 hp and a top speed of 330 km/h.

**1991**

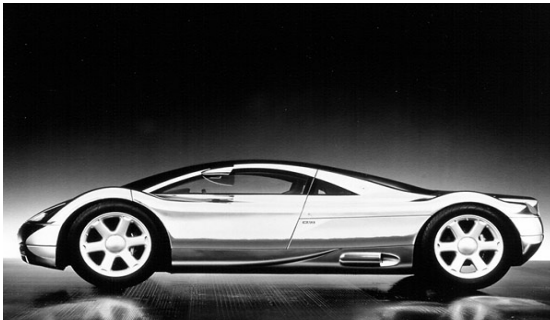

Tokyo Motor Show. Audi presents the legendary Avus sports car concept with a W-12-cylinder and 509 hp.

**2001**



Launch of the Audi A8 L 6.0 quattro and Audi A8 6.0 quattro long and normal wheelbase in Europe, with a W12 engine and 420 hp and 406 lb-ft. Not available in the US/Canada.

**2004**



World Premier of the new Audi A8 L W12 quattro at the Detroit Motorshow. Audi continues the 12-cylinder legend in the new A8 with a W12 engine and 450 hp. Market intro US/Canada end 2004.



**Model / Engine:**

**(Differences to A8 L 4.2):**

- **W12 6.0** liter DOHC aluminum alloy, 4 valves / cylinder
- **12 cylinders, 5998 cc** (366 CID)
- **450 hp @ 6200 rpm, 428 lb-ft @ 4,000 - 4,700**
- 0-60 mph in **5.0 seconds**
- fuel mileage **15 city/ 21 highway, 17 combined**
- curb weight **4,729 lbs** (2,145 kg)
- front brakes 15.2" ventilated disc, 2 piston calipers
- rear brakes 13.2" ventilated disc, 1 piston calipers
- track front / rear **63.74 / 63.10 in** (1,619 / 1,605 mm)

**Add. Standard Equipment:**

**(to MY06 A8 L 4.2)**

- **19" 12-spoke polished** forged alloy wheels
- 255/40 R19 100Y all-season tires
- **Wood leather segmented** four spoke multi-function **steering wheel** with shift paddles and matching wood shift knob. (new for 2006) currently n/a with amaretti
- **Heated front & rear seats**, ski sack
- **Front seat ventilation & massage**
- **Exclusive piping & stitching** on seats and headrests
- Power **side** & rear **sunshades**
- **Power trunk** open/close
- **Power door** close assist with **power rear childlock**
- Rear **vanity mirrors**
- **Advanced key** - keyless entry & start
- **Dual pane** security glass
- **Four zone climate control** incl. rear climate control
- Door armrest, center console and **lower dashboard in leather with premium stitching**
- **Alcantara** headliner, hatshelf, sunvisors, B-pillars
- **Acoustic Parking** system front & rear with graphic display
- **Rear Seat Entertainment System** with 2 screens in front headrests, DVD changer, headphones, remote
- **4-seating** configuration with 2 individual power rear seats with 4-way power lumbar, extended rear center console

**Additional Options:**

**(to MY06 A8L 4.2)**

- **Full Leather Upgrade**
- **20" wheels** with 275/35 R20 performance tires

- New single-frame grille - exclusive to A8 L W12 quattro are horizontal chrome strips and W12 badge as an active, 3-dimensional symbol symbolizes power and character.



New single-frame grille for U.S. without license plates.

**New for 2006:**



Adaptive Bi-Xenon headlights (AFS2 curve light like C6) with LI daytime running lights in distinctive 5-pointed star design

- Trapezoid shaped exhaust tailpipes, integrated in the rear bumper, suggest the elegance and power of 12-cylinders.

- W12 Badging: "W12" and "quattro" badge on right side of trunk lid  
**New for 2006:** "W12" badge on front fenders & left side of front grill  
"W12" on door entry sills



Trunk lid



Door handles

- Exterior door handles with chrome strips (Advanced key)



← Exclusive 19" 12 spoke polished wheels with all season tires

Optional 20" 9-spoke wheels with performance tires →



2005 W12 Side moldings

**New for 2006:** W12 badging on side of car is relocated from side moldings to front fenders.



**2006 Audi A8 L W12 quattro  
Interior Design Highlights**



- W12 badge on door entry sills
- Exclusive Piping and Stitching on all seats and headrests
- Power front seats, heated, with perforated Valcona leather, seat ventilation, massage function and 4-way power lumbar support. (optional for A8 L 4.2)

- Lower Dashboard, Door Panel, Door armrests, Center Console in Leather with Premium Stitching



- 4-Spoke Multifunction Segmented Wood Leather Steering Wheel with Shift Paddles and Matching Wood Shift Knob. **New for 2006** (note currently not available with amaretto interior)  
New trapezoid shaped airbag modul transfers Singleframe Grille design to the interior.



- Exclusive Aluminum inlay beneath wood inlay
- Alcantara Headliner, Hatshelf, B-pillar and Sunvisors (optional for A8 L 4.2)
- Four Zone Climate Control (optional for A8 L 4.2)

- Individual Heated Power rear seats with fore/aft, inclination adjustment, easy entry function, perforated Valcona Leather, 4-way power lumbar support.
- Exclusive extended rear center console with headphone jacks for Rear Seat Entertainment System and additional storage compartment.



- Exclusive Rear Seat Entertainment System with 2 displays in the front headrests, 6 DVD Changer (in trunk), remote control, headphones and headphones jacks in rear center console.



European Model shown

- Singleframe grille with W12 badge
- 6.0L DOHC W12 engine with 450 hp and 428 lbs-ft of torque
- 95% of maximum torque available over a wide range from 2,300 - 5,300 rpm
- 6-speed Tiptronic<sup>®</sup> Transmission (MB S600 & VW Phaeton only 5-speed)
- quattro<sup>®</sup> IV permanent all-wheel drive (not available on MB S600 & BMW 760)
- Multi-Media Interface (MMI) including retractable 7" color screen
- Audi Space Frame (ASF), III generation
- Driver adjustable full adaptive air suspension
- Benchmark interior design and craftsmanship
- Exclusive piping and stitching on seats and headrests
- Extensive standard equipment, including
  - Rear Seat Entertainment System with 2 displays in headrests
  - Individual power rear seats with extended center console
  - Front Seat Ventilation & Massage, Power lumbar and heated seats front & rear
  - Leather Upgrade, Alcantara Headliner & Hatshelf, Four zone climate control
  - Adaptive Bi-Xenon headlights (**AFS 2**) with LED daytime running lights
  - DVD Navigation, Bose<sup>®</sup> Premium Sound System

underlined items - exclusive for A8 L W12 quattro, not available for A8 L 4.2 or A8 4.2

02/04

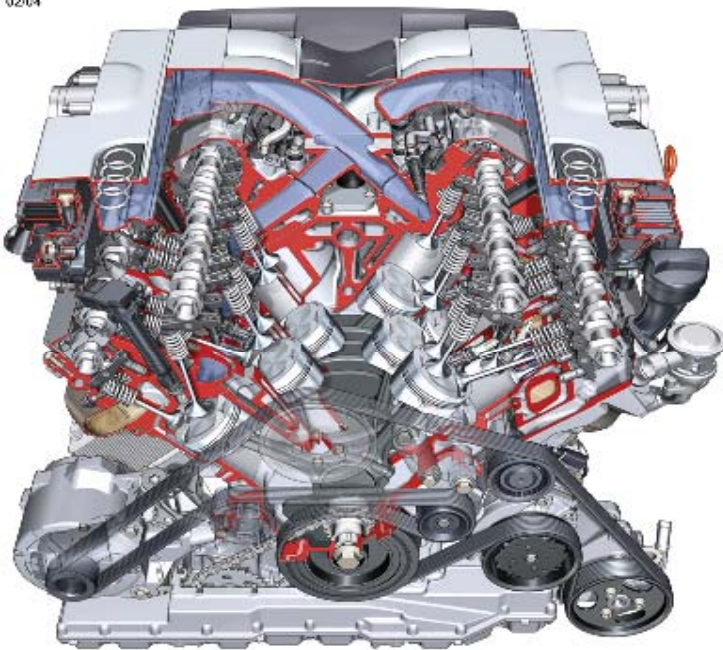

**W12 Engine Features:**

- 6.0l, 5998 cc (366 CID), 12 cylinders, 48 valves
- 450 hp @ 6,200 rpm
- 428 lbs-ft. @ 4,000 - 4,700 rpm
- 15° V-angle and 72° bank angle
- Aluminum engine block
- cross flow cylinder head with 4 valves
- Double overhead camshafts per cylinder bank; driven by a single chain, with low-low-friction roller cam followers
- Infinitely variable timing control for camshafts (52° at inlet and 22° at exhaust valves)
- Bosch Motronic ME 7.1.1. with electronic sequential injection, includes electronic throttle control, hot-film air-mass sensing, cylinder-selective knock control via 4 sensors and permanent lambda control

Compact and powerful - the W12 engine in the Audi A8 is only 513 mm long and 690 mm wide

**Powerful:**

- 428 lb-ft of torque available between 4,000 and 4,700 rpm
- 95% of maximum torque available over a wide engine speed range from 2,300 to 5,300 rpm

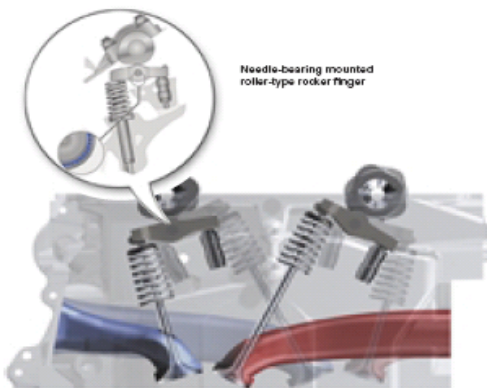

- Needle-bearing mounted low friction roller cam followers

**Torque / Horsepower curves**

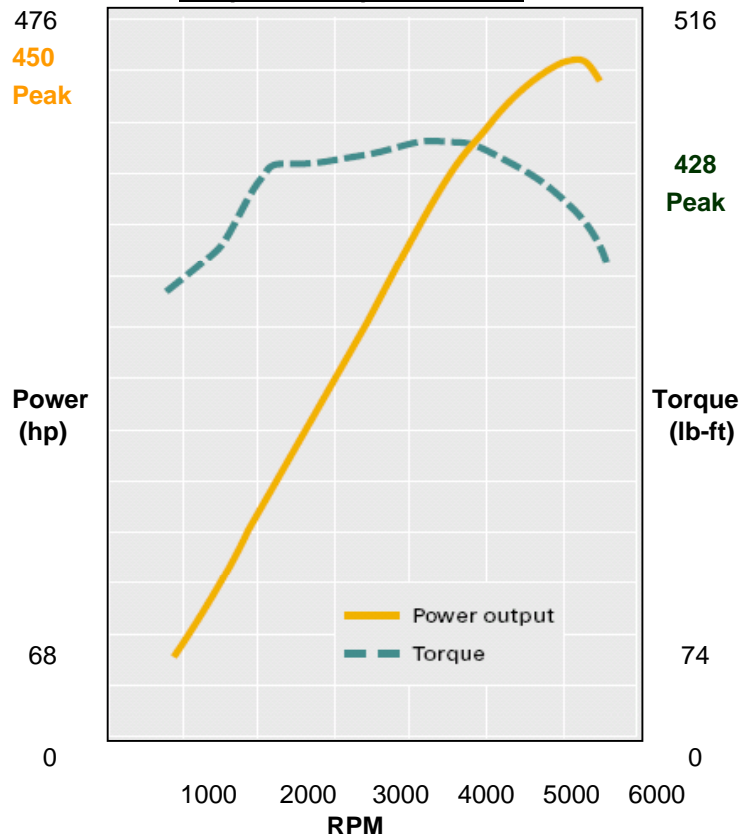



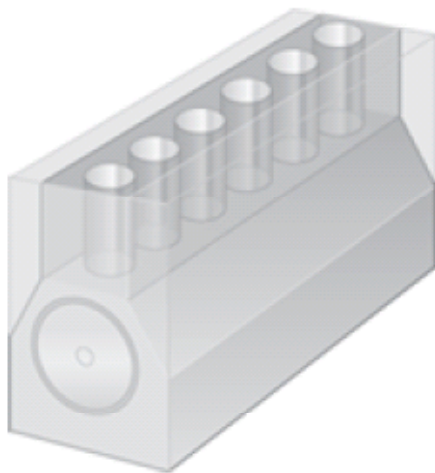

In-line engine

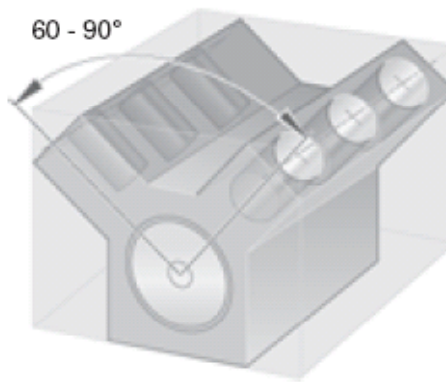

V-engine

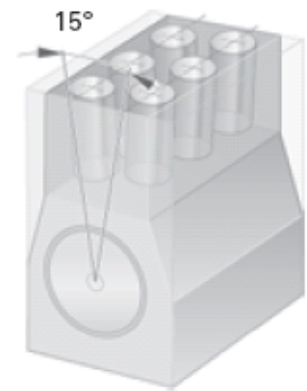

VR-engine  
(V-engine with  
small V-angle)

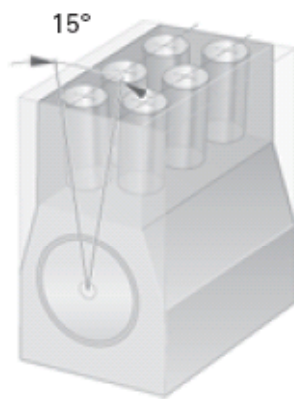

VR-engine

+

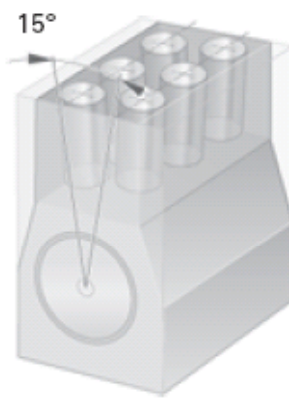

VR-engine

=

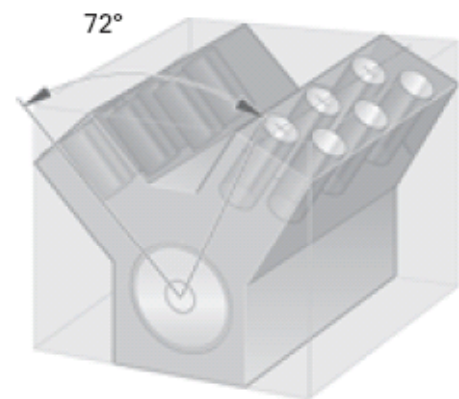

W-engine

- W engine design offers a more compact design in relation to the number of cylinders and , as a direct advantage over BMW 760Li and Mercedes S600, allows for a **combination of 12 cylinders with quattro all-wheel drive**
- The Audi W12 engine, developed together with VW, has 2 connecting rods per crank pin. W-engines in the classic sense have 3 separate cylinder banks, where 3 connecting rods are mounted on a single crankpin.
- The Audi W12 engine consists of two ultra-compact VR6 units. Each of the two cylinder blocks contains 6 cylinders arranged in pairs at an angle of **15° (V-angle)**. The cylinder blocks are joined at a **bank angle of 72°** with a joint crankshaft.
- **Advantages of the Audi W12 engine:**
  - **running smoothnes** of an inline engine (high rigidity, low level of vibrations)
  - **short, compact design** of an V-engine (513 mm long, 690 mm wide)
  - combination of 12-cylinders with **quattro all-wheel drive**
  - use of light metals such as aluminum and magnesium



## 2006 Audi A8 L W12 quattro

### Engine : Differences to predecessor and VW Phaeton



The W12 engine was first introduced in the predecessor A8 in 2001. This engine was not available in the U.S. or Canada. For the 2005 A8 L W12 quattro, the engine was refined:

#### Performance:

- 450 hp @ 6,200 rpm (vs. 420 hp @ 6,000 rpm)
- 428 lbs-ft. @ 4,000 - 4,700 rpm (vs. 406 lb-ft @ 3,250 - 4,250 rpm)
- 6-speed transmission
- Fuel consumption n/a

This increase in performance and fuel consumption compared to the W12 in the previous A8 and the VW Phaeton W12 was accomplished through:

- **reduction of friction losses of moving parts**
- **weight reductions** (conrods, pistons, wet sump lubrication)
- **reduction of exhaust system back pressure**

#### Performance enhancing measures:



Intake manifold - new design, optimized length

- larger throttle bodies to improve air flow
- Optimization of intake manifold length to reduce pulsation in intake port
- Modulation to engine control unit
- lighter pistons and connection rods (better fuel consumption, spontaneous acceleration)
- Reduction of exhaust system back pressure by more than 70mbar (performance)
- vent bores in engine block to reduce piston movement counterpressure (performance)
- increase in nominal engine speed to 6,200 rpm

#### Oil circuit design changes

- wet sump lubrication with fewer components (weight reduction)
- 2 oil separators on the air intake collector pipe, with direct oil return to the cylinder-head rocker covers



Oil filter / cooler module directly mounted to crankcase

#### Exhaust emission control measures:



One unit: air gap insulated exhaust manifold and 3-way catalyst in close proximity to engine

- 4 ceramic monoliths positioned close to the engine make for fast response in conjunction with reduced heat loss from the 4 manifold catalyst modules
- 8 oxygen sensors contribute to better exhaust quality
- pneumatically controlled exhaust flaps in rear silencers

## Audi 6-Speed Tiptronic Transmission

### Features/Benefits

- 6-Speed Tiptronic Transmission (MB S600 & VW Phaeton W12: 5-speed)
- spontaneous power flow, high performance and perfectly refined running
- spread between lowest & highest ratios increased to 6.04
- Dynamic Shift Program (DSP) automatically adjusts to driver's driving style
- Sport Program can be selected on shifter
- Shift Paddles on Steering Wheel

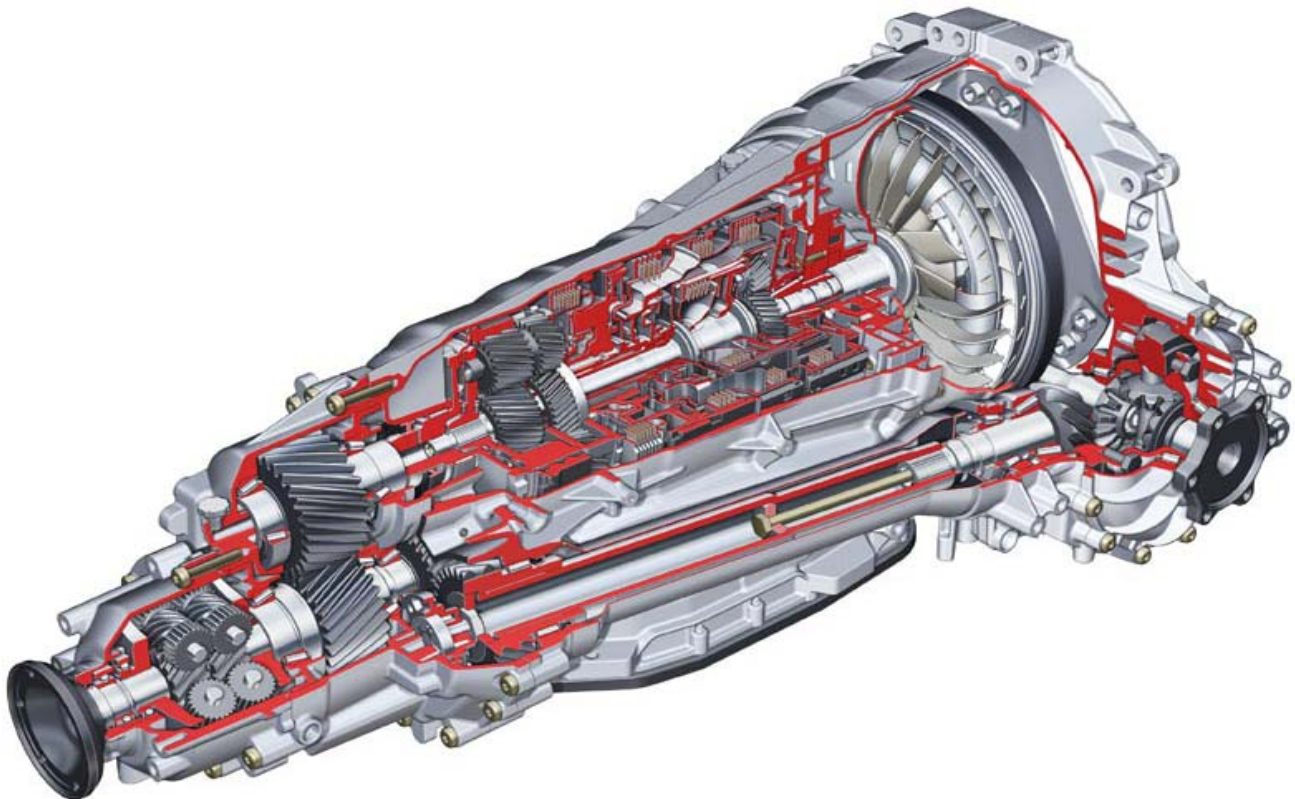

**The 6-speed Tiptronic transmission is the exclusive transmission used on the Audi A8**

The Audi A8 L W12 quattro - 12-cylinders with Aluminum Space Frame, Adaptive Air Suspension, 6-speed transmission and quattro all wheel drive. A combination that converts engine performance with superb efficiency into propulsion and cornering stability, and effortlessly translates the immense torque onto locomotion.

## Audi Space Frame (ASF III)

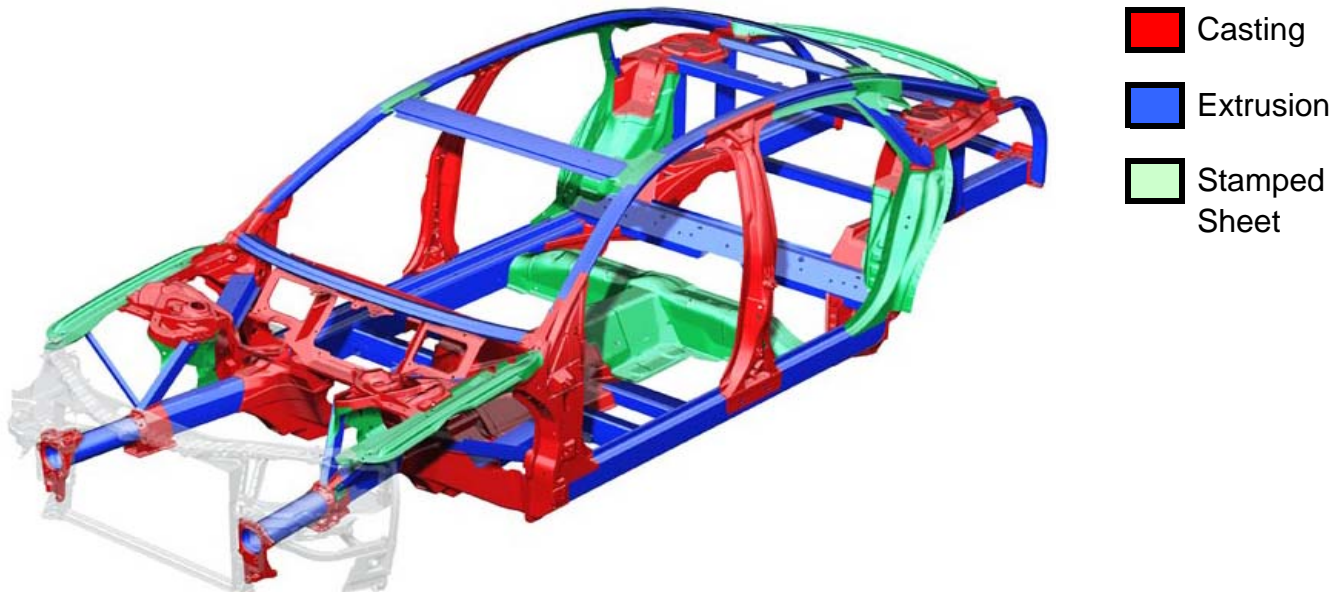

### Improvements over previous version of the Audi Space Frame:

- 60% Increased Rigidity
- 17% Less Parts
- 300 lb weight savings vs. conventional steel frame, thereby improving handling
- New laser-hybrid welding technique developed for better quality / more efficient welds

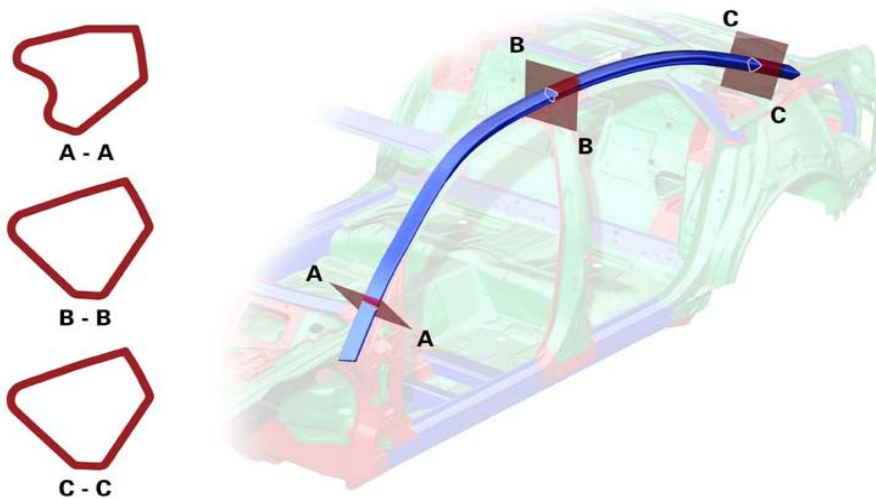

### Extrusions

Hydroforming processes allow Audi to use extrusions with varying cross-sections. This enables the perfect cross-section design to be used at all points along the extrusion, thereby increasing strength and rigidity while enhancing functionality.





- **Infinitely adjustable adaptive damping** system
- **Four corner air suspension** with air spring struts at each wheel
- **Automatic self-leveling** regardless of load
- **Various handling modes** (combination of damping characteristic and ground clearance) can be selected via MMI.
- **For outstanding dynamic handling combined with excellent ride comfort at all road conditions.**

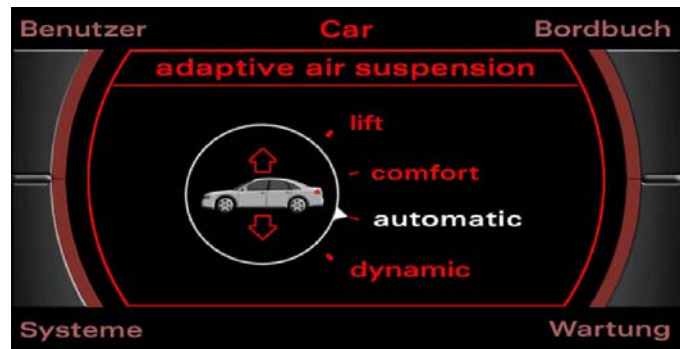

\* US/Canada: "comfort" mode renamed to "standard"

### Adaptive Air Suspension

- **Lift Mode**
- **Standard Mode**
- **Automatic Mode**
- **Dynamic Mode**

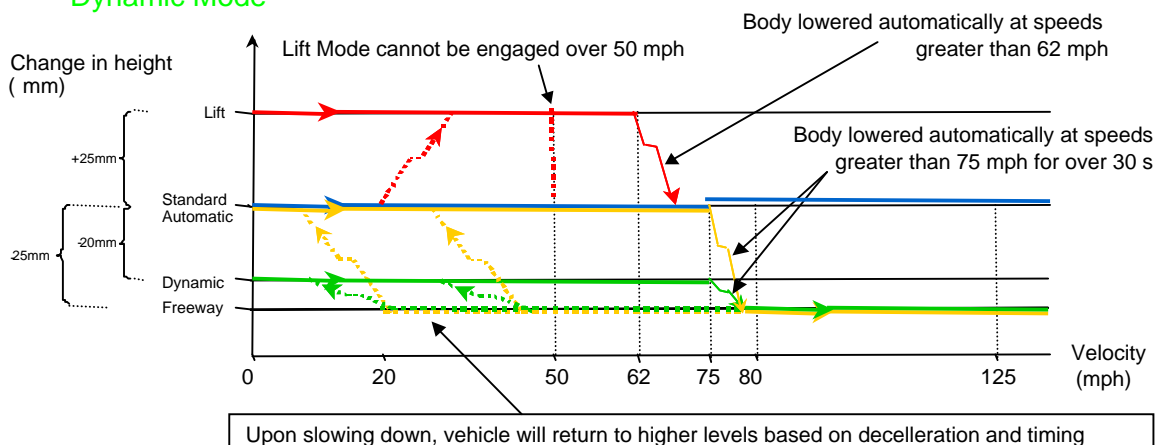



**2006 Audi A8 L W12 quattro  
Interior Details**



A8 L W12 quattro shown with 4-spoke multifunction heated steering wheel & leather shift knob (available at no cost)

**A8 L W12 quattro - Interior design highlights (additional to A8 L 4.2 quattro):**

- Genuine wood inlays in Birch Beige, Brown polished walnut & Sycamore with exclusive aluminum inlay below wood
- Door armrests, and Center Console, Lower dashboard, Door panel and glovebox in Leather with Premium Stitching
- Alcantara headliner, hatshelf, and sunvisors
- Premium Comfort Seats with high-grade perforated Valcona leather, driver & passenger memory, 16-way front seat ventilation & massage, heated front & rear seats, front & rear power 4-way lumbar
- Exclusive Piping and Stitching on seats and headrests:
  - Platinum seats with Gray Piping / Stitching
  - Black, Sand Beige & Cream Beige seats with clay Piping / Stitching
  - Amaretto seats with black Piping / Stitching
  - No piping / stitching for blue interior
- Two individual power rear seats, heated, with 4-way power lumbar and extended rear center console with storage compartment, headphone jacks for Rear Seat Entertainment System, and climate controls for standard four zone rear climate control (4 seating configuration)
- 4-spoke multifunction segmented wood leather steering wheel with shift paddles and matching wood shift knob
- Power door close assist with power rear childlocks, power trunk open/close
- Power side and rear sunshades
- Advanced Key with start/stop button on center console
- Bluetooth cell phone preparation with voice control for phone, CD, radio, navigation
- Rear Seat Entertainment System with 2 displays in front seat headrests, 6 DVD Changer, remote control, 1 set of headphones, 2 A/V and 2 headphones connections.
- W12 on door entry sills
- Bose Premium sound system with 6 CD changer
- DVD Navigation with display in 7" retractable MMI screen

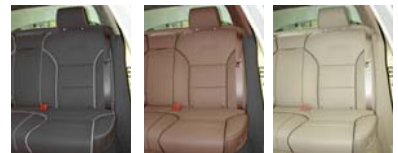

underlined items - exclusive for A8 L W12 quattro, not available for A8 L 4.2 or A8 4.2

## 2006 Audi A8 L W12 quattro Safety Features



- Driver and front passenger dual-stage, dual-threshold next generation airbag supplemental restraints \* for front crash protection.
- Driver annular airbag\*, unfolds radially and provides particularly effective protection for occupants who are closer to the steering wheel.
- Front 3-point safety belts, autom.pretensioning, height adjustable upper mounts & force limiters
- Three rear 3-point safety belts with automatic pretensioning and angle adjustment
- Two active front head restraints, automatically pivot forward in the event of a rear-end collision to support the driver's and front-passengers heads. Three rear head restraints.
- SIDEGUARD head protection airbag supplemental restraints\* for front & rear occupants, covers window area (A to C-pillar), remains inflated longer to cover secondary effects & crash intrusions
- Front and rear side airbags\*, mounted in the seats
- Driver and front passenger knee protection airbags \*
- Six crash sensors (two in front and two on each side) rapidly determine which airbags deploy, and when. These sensors, depending on crash severity can initiate:  
Switch on hazard lights, shut off engine and fuel pumps, unlock vehicle, switch on interior light,
- LATCH (Lower Anchorage and upper Tether CHild seat) provisions in rear seats
- Aluminum Space Frame (ASF), provides a stable occupant cell with footwell intrusion in conjunction with a balanced deceleration pattern
- High-performance braking system with ventilated discs and aluminum floating calipers
- ESP (Electronic Stabilization Program) integrating the following safety features:  
ABS (anti-lock braking system), ASR traction control, EBD electronic brake-force distribution, and hydraulic brake assist
- Safety steering column; telescopic, energy absorbing column
- Foot protection through energy absorbant padding and crash-optimised pedal assembly
- Tire pressure monitoring system for all four wheels and the spare tire
- LED Brake lights, proven to sharpen the reaction time of drivers in vehicles behind

\* Airbags are supplemental restraints only and will not deploy under all circumstances. Always use safety belts and seat children only in the rear, using restraint systems appropriate for their size and age.

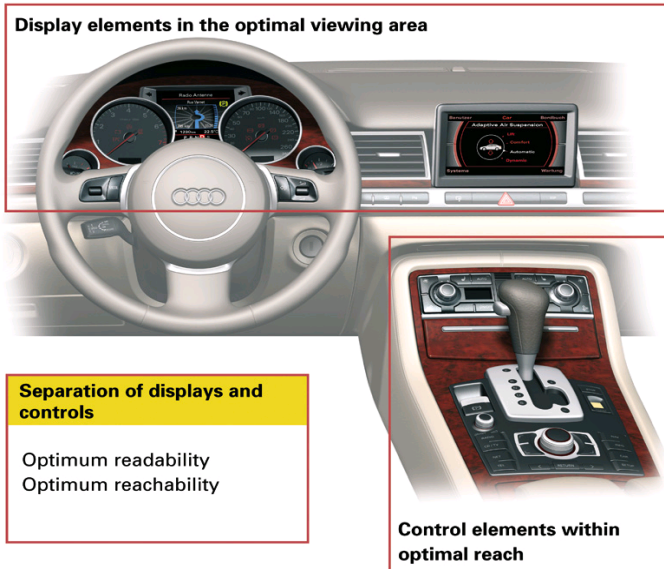

MMI functions can be controlled from the multifunction **steering wheel** controls (thumbwheels with push-button function) or the **MMI control knob and buttons in the center console**. The MMI buttons shown control the radio, CD, navigation, and many other vehicle settings such as the adaptive air suspension - greatly minimizing the number of buttons necessary in the interior.

MMI functions can be viewed from two separate screens: in the **main instrument cluster** and in the 7" **MMI screen** located in the center console which can be stowed electronically for reduced driver distraction.

The Audi Multi Media Interface (MMI) follows a simple and logical 4-step principle:

**The customer notes 4 things:**

- 1 Main functions called up directly via key
- 2 Selection via turn/push button
- 3 4 screen corners correspond to the 4 keys around turn/push button
- 4 Press "Return" to move back up a level

\* NET button changed to NAME

The new Audi parking system with graphic display includes the previous front and rear parktronic audible warning as well.





## Bose 12-Speaker Premium Surround Sound System

### Features

- ◆ Standard equipment on Audi A8 4.2 quattro and A8 L 4.2 quattro
- ◆ 12-Speakers including 12-inch woofer
- ◆ Surround Sound capability
- ◆ Bose AudioPilot electronic noise compensation technology
- ◆ DSP (Digital Signal Processing)

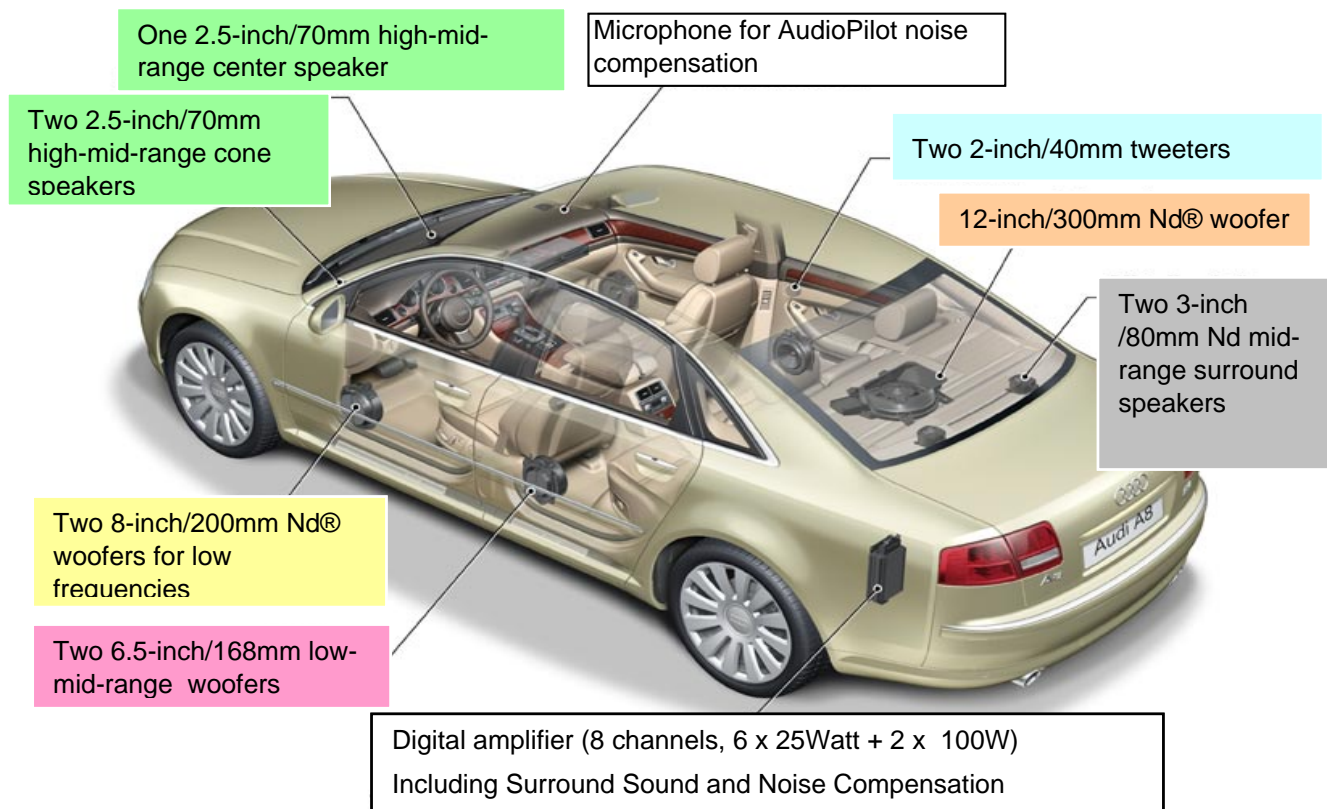



## 2006 Audi A8 L W12 quattro Lighting

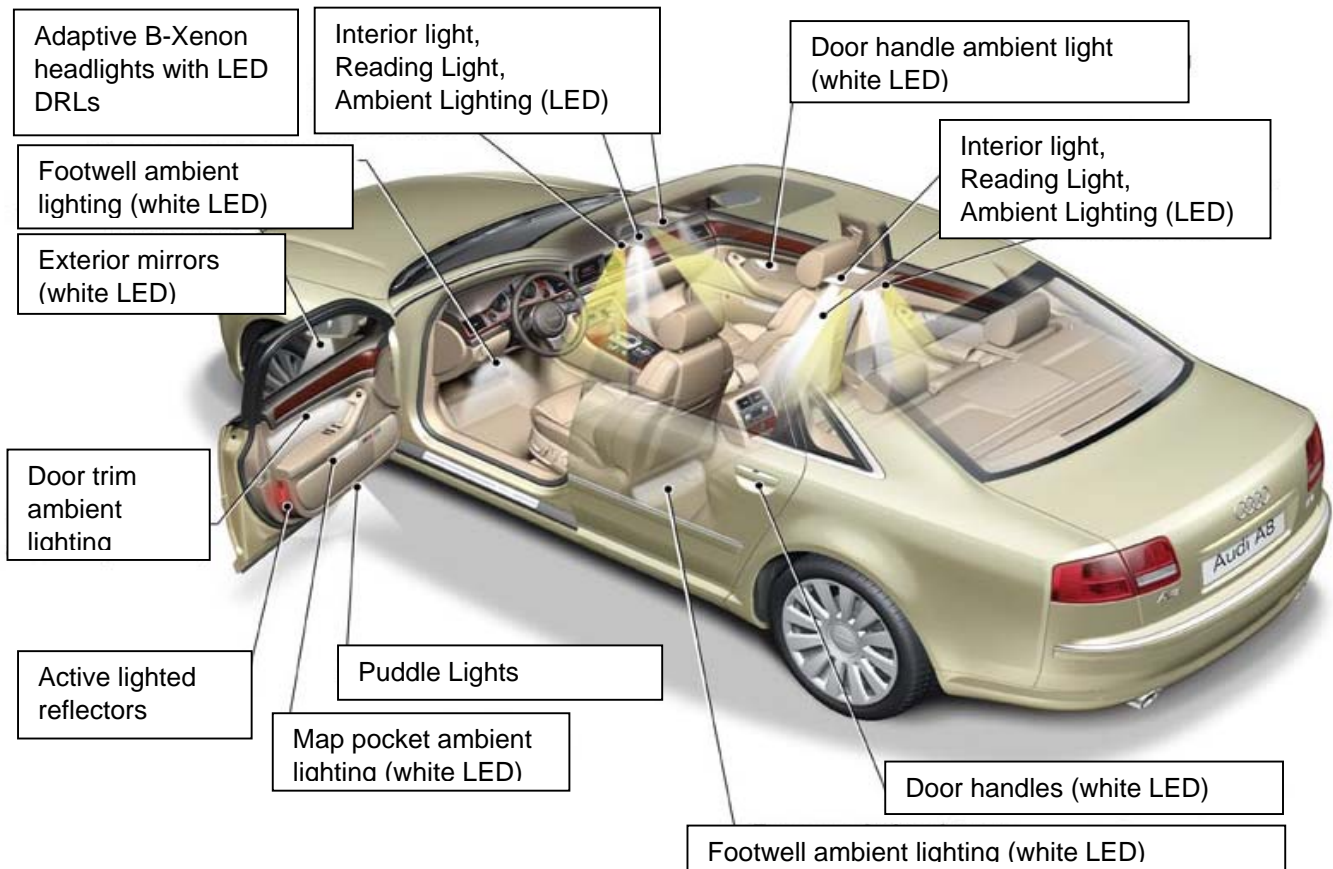

**Adaptive Bi-Xenon headlights**



**Unmistakeably A8 L W12 - 5-pointed star type front lights**

The Audi A8 L W12 quattro is the first car in the world to be equipped with adaptive Bi-Xenon headlights with LED daytime running lights, whose distinctive 5-pointed star type lighting elements also have a dual function as new design features for the front end. **For MY 2006 all A8's will get the AFS2 "curve" adaptive lighting like A6.**

Thanks to LED daytime running lights, the A8 L W12 is the first vehicle in the world on which the use of DRLs adds virtually nothing to fuel consumption.

Audi's use of LED technology is prevalent in both the **interior** (different light profiles programmable via MMI) as well as in the **exterior** (daytime running lights, rear tail light, rear brake light and third raised brakelight, rear indicator light and side turn indicators). The rear lights are a clear demonstration of how design quality is combined with functionality and state-of-the-art technology: the use of LEDs offers a number of advantages over conventional bulbs:

- brilliant depth
- quicker illumination, proven to sharpen reaction time of the driver behind
- longer service life (at least 10,000 hours, i.e. an entire vehicle's lifetime)
- require less space and so benefit the vehicle's luggage capacity
- consume up to 50% less energy than light bulbs, thus helping fuel consumption

**The new Audi A8 L W12 features 2 types of Adaptive Bi-Xenon headlights as standard fea:**

- Adaptive Light in the A8 L W12 activates an extra headlight to better illuminate curves and the edge of the road when turning or driving through a curve. An additional static reflector.

**Adaptive Light will get activated:**



- on the appropriate side of the vehicle if the turn signal lever is actuated all the way down or up (not "lane changer")
- automatically when driving through tight corners, depending on the steering angle
- on both sides when the reverse gear is engaged to improve peripheral vision and orientation when driving backwards
- only when driving up to a speed of 43 mph (70 km/h)
- only when low beam headlights are turned on

**Features:**

- LED daytime running lights for optimum visibility & unmistakable appearance
- first vehicle in the world on which DRLs have no adverse effect on fuel efficiency
- additional 35-watt reflector between high & low beam headlight, illuminates an area around 90° in relation to direction of travel. Increases the driver's field of vision.

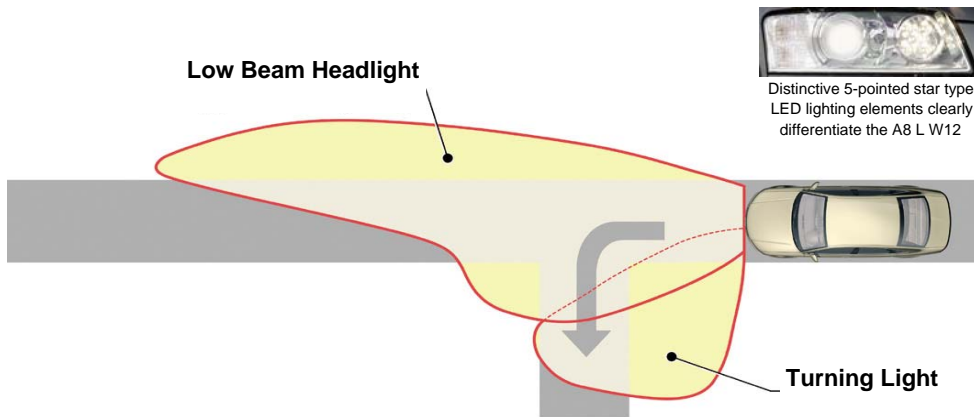

- Adaptive light in the A8 L W12 now also has the same pivoting headlights as the A6 (AFS2)



**Audi A8 L W12 quattro exclusive feature**  
Additional static 35W reflector  
LED daytime running lights  
Turning Lights



**New Audi A6/ A8/ W12**  
Pivoting headlights  
Daytime running lights

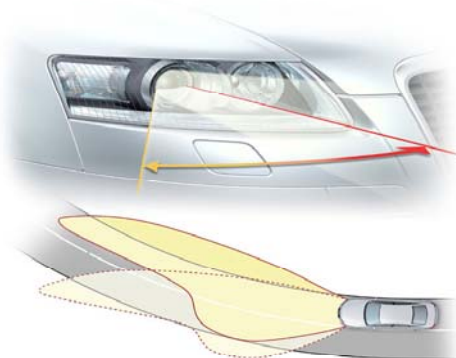

The 2006 W12 will now offer the same pivoting bi xenon headlight as the A6 (AFS2) Which pivots up to 15 degrees to the left or right. It pivots as a function of speed and steering angle.

## 2006 Audi A8 L W12 quattro Advanced Key



The Audi Advanced Key is standard equipment on the new Audi A8 L W12 quattro.

Advanced Key permits the driver to unlock and lock the vehicle as well as start and stop the engine without having to take hold of the key fob. A signal transmitter in the key releases the central locking when the vehicle is approached and allows the engine to be started at the push of the starter button as soon as the key is in the driver's cell inside the car.

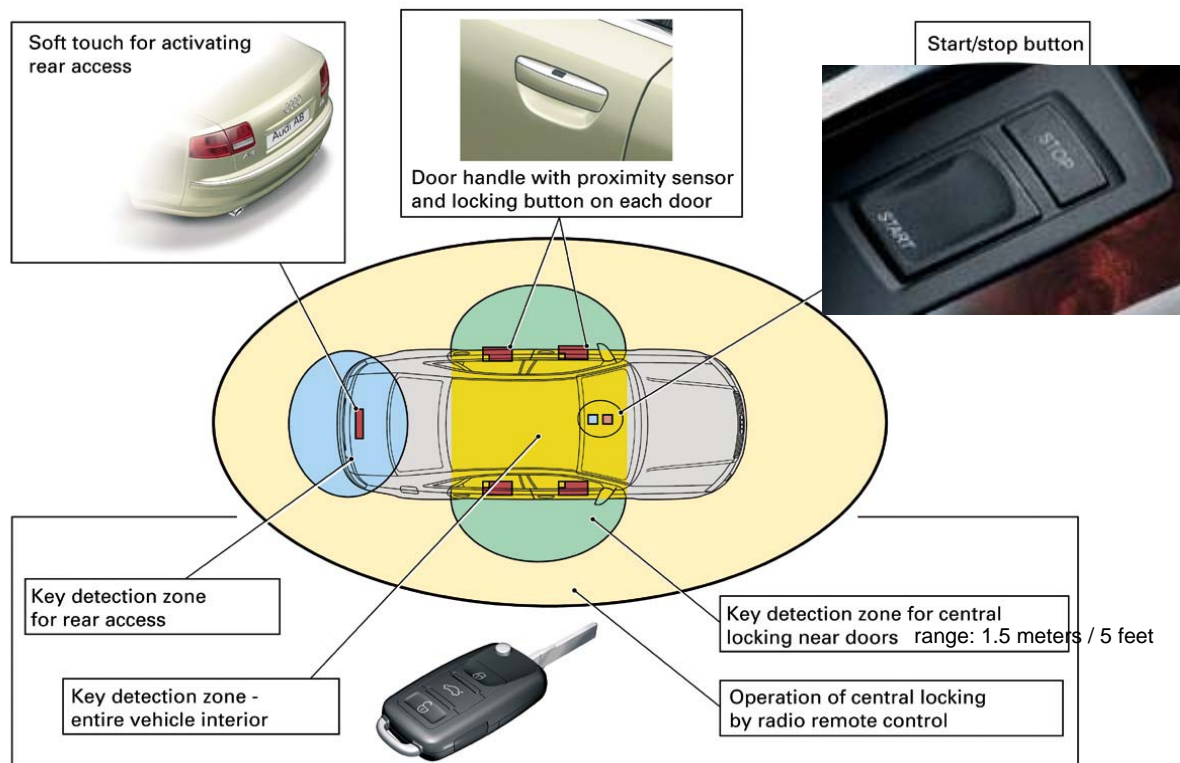

### Audi Advanced Key includes

- proximity sensors in all doors and trunk lid
- chrome strips on all door handles with locking button
- Engine start/stop button on the center console above the MMI terminal

### Unlocking & Locking the vehicle:

- The authorized key fob must be within 5 feet (1.5 meters) from one of the vehicle doors or the trunk lid
- Actuating the door handle will start the key evaluation process for access authorisation (radio dialogue)
- Doors can be unlocked in general or individually as specified in the MMI (driver's door will always unlock)
- Trunk lid can be opened using the soft-touch button if the key is within the rear detection range
- To lock the vehicle, shift lever has to be in P. When the authorised key is within 5 ft., the vehicle can be locked by touching the locking buttons on the door handle. The door cannot be unlocked immediately after it has been locked to allow the driver to check whether it has been locked properly.

### Starting / Stopping the engine:

- Pressing the START button once will turn on the ignition. Pressing the START button all the way down to position 2 will start the engine when the shift lever is in P or N, and the brake pedals are applied.
- Pressing the STOP button will stop the engine if the vehicle is at a complete stop with the shift lever in P or N. Pressing the STOP button a second time and longer while in P will lock the steering wheel.

! *Pressing the STOP button will not stop the engine while driving (or when the key is thrown out of the window - do not attempt!). However, if circumstances require to do so, the engine can be stopped when driving up to a speed of 6 mph (10 km/h) with shift lever in R, D, or S when pressing and holding the STOP button and the brake pedal at the same time (**Emergency OFF function**).*



## 2006 Audi A8 L W12 quattro Four Zone Climate Control



The Audi A8 L W12 quattro features a **four-zone climate control as standard equipment**. Temperature and air distributions for all four outboard passengers can be adjusted separately through dedicated climate controls in the instrument panel in the front and the rear center console. Individual climate control preferences are **stored to the key-fob** (Memory function).

Climate controls are **independent of the MMI controls** but follow the MMI logic, with the 7" retractable MMI screen serving as a convenient **display**. Main climate settings such as temperature, air distribution, fan output and defrosting can be adjusted directly at the climate control unit. The climate controls refer to the four corners of the MMI screen.



**Dedicated Climate controls**



**Front climate controls - the MMI screen serves as a convenient display**



**Rear climate controls located in rear center console (extended rear center console for 4-seating configuration).**

Further functions such as synchronization can be called up in the climate control Setup menu.

The rear air conditioning controls are located in the rear center console. Both temperature and air distribution can be adjusted individually for the left and right side. In addition, output air is heated separately for the left and right side by silicon footwell heaters. The rear air conditioning can also be adjusted from the front through the Setup menu in the front climate control operating unit.

### Features:

- **separate** temperature and air distribution controls for all four outboard passengers
- **indirect**, draught-free ventilation
- **sun sensor** (adjust air temperature/distribution according to direct sunlight exposure)
- **humidity sensor** (regulates air moisture to reduce interior window fogging)
- **particle filter** with activated charcoal (absorbs pollutants when fresh air is drawn in)
- **air-quality sensor** (activates air recirculation function depending on outside air quality)
- **residual heat** function (operates heater when ignition is off via ON/OFF button)

### Air outlets:

- four front outlets in dashboard
- five front outlets on top of dash
- six front footwell outlets
- two outlets in rear center console
- four outlets in rear door pillars
- rear footwell outlets

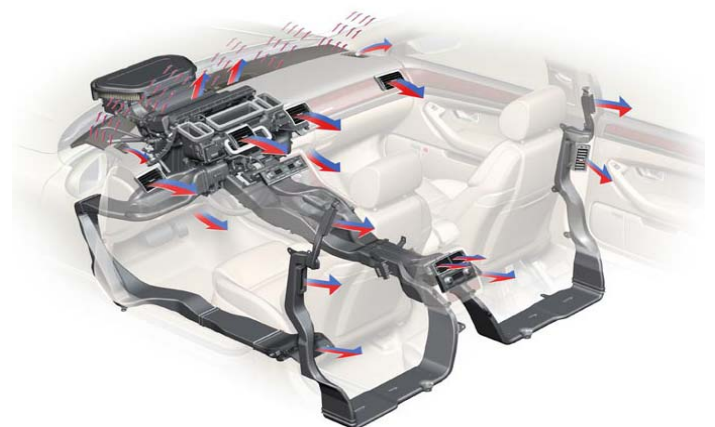

**Attention to detail is an Audi hallmark - air is reheated before reaching the rear footwells.**



## 2006 Audi A8 L W12 quattro Satellite Radio



- A choice of SIRIUS and XM is available as a **factory installed option** for the 2006 Audi A8 L W12 quattro in the U.S.
- All U.S. A8 models already come with a satellite radio preparation as standard equipment (roof antenna and wiring). Customers can order satellite radio directly from the factory, or as an accessory for installation before taking delivery.
- Factory installed Satellite Radio is covered by the Audi Limited Warranty (4 years or 50,000 miles), Satellite Radio purchased after the sale or lease is covered under the Spare Parts Limited Warranty (12 months or 12,000 miles).
- Satellite radio offers more than 60 music channels, all of them commercial free, along with news, talk, sports, kids, comedy and entertainment channels. Channel lineups are organized into categories and displayed on the MMI screen and the driver information display. Music channels also show the artist and song title that is currently played on the MMI screen.
- Channel guides can be viewed and printed at the following links:  
**Sirius** <http://www.sirius.com/pdf/channelguide.pdf>  
**XM** [http://www.xmradio.com/programming/full\\_channel\\_listing\\_print.jsp?sort=number](http://www.xmradio.com/programming/full_channel_listing_print.jsp?sort=number)
- Customers can activate the service by providing their ID number found on channel 0 and the Audi specific promotion code to SIRIUS or XM customer service, or online (XM only). During activation, the radio must be on "SAT" mode with the antenna exposed without overhead obstructions. Activation should be immediate (15 min. max)
- Satellite Radio is only available in the Continental U.S. Activation and first 3 months of service free of charge. Subscription required after 3 month trial period.



- Over 100 streams of music, news, sports, talk and entertainment
- Superior digital quality audio
- Coast-to-coast coverage
- 61 streams of 100% commercial-free music
- Over 40 streams of news, talk, sports, kids, comedy and entertainment channels; 21 are SIRIUS exclusive
- SIRIUS is the only satellite radio service providing complete play-by-play coverage of all major sports leagues including the NHL, and beginning August 2004, the NFL. SIRIUS is the official satellite radio partner of the National Football League.
- SIRIUS FIRST TRAFFIC & WEATHER delivers around-the-clock, nonstop traffic and weather reports for the 20 most congested cities across the country to all SIRIUS subscribers. Please check the latest stream listings at [www.sirius.com](http://www.sirius.com) to find your local market.
- Live in-studio performances and remote broadcasts
- Real-time sports scores and continuous market updates delivered to radio display
- Exclusive programming: NFL, NPR, Court TV Plus, The Word Network, and many more
- \$12.95 per month



- Over 120 digital channels of music, news, sports and talk
- Superior digital quality audio
- Coast-to-coast coverage
- 68 channels of 100% commercial-free music
- 32 news, talk, sports, kids, comedy and entertainment channels; 18 are XM exclusive
- 21 exclusive channels of XM Instant Traffic & Weather
- Comprehensive sports coverage from the leading sports networks including ESPN and ESPNNews; XM is also the exclusive satellite radio provider of NASCAR Radio, FOX Sports Radio and Sporting News Radio.
- Live original programming and call-in requests
- The only satellite radio service to offer: MTV, VH1, CNN, MSNBC, Cinemagic
- The best names in news and talk, with the biggest talk stars on satellite radio
- \$9.99 per month

## 2006 Audi A8 L W12 quattro Bluetooth Cell Phone Preparation and Voice Control



The 2006 Audi A8 L W12 quattro features a **Bluetooth® cell phone preparation** and a **voice control system** as **standard** equipment.

### **Bluetooth® cell phone preparation (Standard Equipment):**

Your Audi vehicle is equipped with a phone preparation utilizing a Bluetooth® interface to enable hands-free functionality (cell phones and cell phone subscription sold separately). The Audi cell phone preparation has the following features:

- Using a Bluetooth connection or an Audi phone cradle, the Audi phone preparation will allow you to place and receive phone calls through the Audi MMI or through the voice control system.
- In addition, cell phone book access and caller ID is available through the MMI and instrument cluster (not all phones support these feature).
- During a call, voice mail can be accessed using the MMI
- Up to four different Bluetooth cell phones can be paired to the Audi cell phone preparation, however only one phone can be connected actively at one time.

You will need a compatible mobile phone in order to utilize this function. Not all Bluetooth enabled mobile phone models are compatible with the Audi phone preparation. Visit our web site, [www.audiusa.com](http://www.audiusa.com) ([www.audicanada.ca](http://www.audicanada.ca)), or contact your local Audi dealer, for the latest listing of compatible phones. Audi recommends the use of the Audi phone cradle (sold separately) with your mobile phone while operating this vehicle.

Depending on the cell phone, different steps are necessary to pair the phone to the car using Bluetooth. Please read the Owner's Manual of your cell phone for further details.

### **Voice Control (Standard Equipment):**

The new voice control system features:

- Voice control is activated via "talk" button on the multi-function steering wheel (short push to activate, long push to cancel)
- Significantly improved voice recognition compared to previous generations of voice control with the ability to dial continuous phone numbers ("2485551212" as opposed to "2" pause, "4" pause, etc.)
- Over 44 voice commands to control the following equipment:
  - **Radio** Specific station selection ("96.3"), band change (AM/FM/Satellite Radio), seek up and down
  - **CD** Specific track, specific CD in changer
  - **Navigation** Navigate to a saved location, special destinations (next gas station for example), last destinations in memory, map zoom control
  - **Phone** Voice input of number or nametag ("Call Brian"), nametags can have multiple phone numbers associated (office, home)
- Additional commands available by saying "Help" at any prompt
- Ability to assign nametags to radio stations, CDs, phone numbers and addresses and recall them using the voice control



Legend x = Standard      o = Optional      p = Package	A8 L W12 quattro®
<b>Exterior Lighting</b>	
<ul style="list-style-type: none"> <li>• Adaptive Bi-Xenon high intensity (AFS2 same as A6), low and high beam headlights with automatic self-leveling, cornering light with auxiliary light bulb, and auto on/off low-beam headlights (lightsensor located in interior rearview mirror housing)</li> </ul>	x
<ul style="list-style-type: none"> <li>• High pressure retractable headlight washers</li> </ul>	x
<ul style="list-style-type: none"> <li>• Two front fog lights located in lower front bumper</li> </ul>	x
<ul style="list-style-type: none"> <li>• Two rear fog lights in portion of taillights located on the decklid</li> </ul>	x
<ul style="list-style-type: none"> <li>• Red taillight lenses with red LED's used as the turn signals</li> </ul>	x
<ul style="list-style-type: none"> <li>• "Puddle" lights in all four doors</li> </ul>	x
<ul style="list-style-type: none"> <li>• LED lights underneath exterior mirrors and side door handles, activated automatically when doors are unlocked and opened</li> </ul>	x
<ul style="list-style-type: none"> <li>• Coming home/leaving home lights programmable via MMI (fog lights, tail lights, licence plate lights and LED lights below mirror and door handle)</li> </ul>	x
<ul style="list-style-type: none"> <li>• Programmable LED daytime running light headlights with distinctive 5-pointed star lighting element</li> </ul>	x
<ul style="list-style-type: none"> <li>• Side indicators with white LED lights</li> </ul>	x
<ul style="list-style-type: none"> <li>• Front clear lenses w/amber turn lights, amber DRL lenses, and side markers w/amber bulbs</li> </ul>	x
<b>Interior Lighting</b>	
<ul style="list-style-type: none"> <li>• Interior lights in front and rear headliner with fade-in and fade-out feature, time delay and automatic switch on when key is withdrawn from ignition</li> </ul>	x
<ul style="list-style-type: none"> <li>• Front and rear reading lights located in headliner</li> </ul>	x
<ul style="list-style-type: none"> <li>• White ambient LED lighting for storage compartments, front &amp; rear footwells, door handles, indirect illumination of the door trims &amp; reading lights in rear headliner. Different light profiles programmable via</li> </ul>	x
<ul style="list-style-type: none"> <li>• Entry/exit lights and active reflectors on all doors</li> </ul>	x
<ul style="list-style-type: none"> <li>• Illuminated front make-up mirrors</li> </ul>	x
<ul style="list-style-type: none"> <li>• Illuminated rear vanity mirrors</li> </ul>	x
<ul style="list-style-type: none"> <li>• Illuminated glove box, trunk, lighter and ashtray</li> </ul>	x
<b>Comfort and Convenience</b>	
<ul style="list-style-type: none"> <li>• Fully automatic dual-zone climate control system with sun sensor, humidity sensor, air-quality sensor, particle filter with activated charcoal, and residual-heat function (via ON/OFF button, heater can operate when ignition is off). Draught-free, indirect ventilation.</li> </ul>	x
<ul style="list-style-type: none"> <li>• Fully automatic four-zone climate control, adds additional rear climate operating unit in rear center console and allows for separate temperature and air distribution settings for each outboard seat.</li> </ul>	x
<ul style="list-style-type: none"> <li>• Power glass sunroof with both tilt and slide functions, tinted safety glass and infinitely variable sunshield, electrically actuated wind deflector (road speed control), automatic pre-select function of sliding roof position, and closing system with pinch protection.</li> </ul>	x
<ul style="list-style-type: none"> <li>• Power Solar sunroof, with solar panel to maintain power supply to the fan when car is parked in the sun. With both tilt and slide functions and electrically actuated wind deflector (road-speed control).</li> </ul>	o
<ul style="list-style-type: none"> <li>• Power windows with: <ul style="list-style-type: none"> <li>- power retention (until either front door open)</li> <li>- "one-touch down" for all four windows</li> <li>- "pinch protection" for all four windows (reverses window at force &gt;100N)</li> <li>- "one touch up" for all four windows</li> <li>- driver controlled lock out switch for rear power windows</li> </ul> </li> </ul>	x
<ul style="list-style-type: none"> <li>• Electronic cruise control with coast, resume and speed-up features</li> </ul>	x
<ul style="list-style-type: none"> <li>• Adaptive Cruise Control (ACC) adapts the vehicle's speed by applying the accelerator and/or brakes to help keep a safe distance to the vehicle driving ahead in the same distance.</li> </ul>	o
<ul style="list-style-type: none"> <li>• Dual auto dimming, power folding outside mirrors with defog feature and memory. Power tilt passenger side mirror when gear is in reverse.</li> </ul>	x
<ul style="list-style-type: none"> <li>• Auto dimming interior rearview mirror</li> </ul>	x
<ul style="list-style-type: none"> <li>• Multi-function 4-spoke wood/ leather segmented steering wheel with MMI controls and shift paddles in Beige Birch or Brown-polished Walnut. Includes matching wood shift knob. Currently n/a with Sycamore wood (amaretto interior).</li> </ul>	x
<ul style="list-style-type: none"> <li>• Multi-function 4-spoke leather steering wheel in dashboard color, heated, with MMI controls, shift paddles and leather shift knob (available at no cost, replaces segmented wheel and wood shift knob)</li> </ul>	no cost option



Legend x = Standard      o = Optional      p = Package	A8 L W12 quattro®
<b>Comfort and Convenience (Continued)</b>	
• Power tilt and telescopic steering wheel column with automatic tilt-away for ease of entry and exit	x
• Fuel tank & trunk lid release button in driver's door	x
• Front and rear Parktronic™ Acoustic Parking System with graphic display	x
• Power central locking system (doors, deck lid and fuel door), with selective unlocking (enables unlocking of a single door or individual doors), plus: - master switch located in all doors - convenient open for windows	x
• Radio frequency remote locking system with selective unlock, remote trunk opening and panic function, remote also activates interior lights and alarm system.	x
• Folding ignition key with remote controls (including rear lid release)	x
• Advanced Key, keyless entry and go system. Includes proximity sensor in door handles and trunk lid and Start/Stop button in the right upper corner of the MMI terminal. Allows for selective unlocking of doors and trunk lid, starting and stopping of the engine, and locking the vehicle without taking hold of the key. Key has to be within 60 inches (1.5 m) of proximity sensor to unlock vehicle and in the driver's cell for starting the engine.	x
• Power trunk "close" for last 1 in. of trunk closing	x
• Power "open/close" for trunk: power "open" by button in remote key, button in the driver's door or soft-touch button in the recess provided in the trunk lid. Power "close" via button on inside of trunk lid.	x
• Power door close assist for last inches of all four doors. Includes Power rear child locks.	x
• Four assist handles with slow retraction feature and integrated reading lights	x
• Power sunshades for rear side windows	x
• Power sunshade for rear window	x
• Right/left illuminated vanity mirrors in sunvisors (normal and magnified mirrors included)	x
• Windshield wipers with 4-position adjustable delay and rainsensor (located in interior rearview mirror housing) - automatically switches on windshield wipers in wet conditions when in intermittent position	x
• 12 V power source in left side of trunk	x
<b>Seating</b>	
• 4-seating configuration with 2 individual power rear seats (fore/aft & inclination adjustment, easy-entry function via MMI) with 4-way lumbar and extended center console in the rear	x
• 5-seating configuration with rear bench for 3 passengers and 4-way lumbar (replaces individual power rear seats and long center console)	no cost
• Premium leather upholstery (Valcona leather seats, perforated) with Alcantara door panel inserts	x
• Piping and Stitching for Seats and Headrests - Black, Beige and Cream Beige seats with clay piping/stitching - Platinum seats with gray piping/stitching - Amaretto Seats with black piping/stitching - No piping/stitching for blue seats	x
• 16-way power front driver and passenger seats with: - 4-way power lumbar adjustment - power fore/aft, height, angle and seatback-angle adjustment - power front head restraint & seat belt height adjustment - power upper seatback adjustment for angle of top third of seatback - power seat depth adjustment (thigh extender) driver's side only (seat foam and upholstery are drawn out, no gap) - 4 memory positions for driver and passenger seat, outside mirrors, head restraint, steering wheel positions and climate control settings	x
• Heated front and rear seats	x
• Front seat ventilation and massage to remove heat and moisture, and to massage and relax back muscles. Seat ventilation by means of fan in each of the front seatbacks/seat bases, activated via button in front climate control unit. Massage through movements of lumbar element, activated via button at side of seat. Comes with perforated leather.	x
• Front seat back map pockets	x
• Power lumbar adjustment for rear outboard positions	x
• 3 adjustable head restraints for rear seat	x
• Concealable center rear headrest	x

2006 Audi A8 L W12 quattro  
Equipment

Legend x = Standard      o = Optional      p = Package	A8 L W12 quattro®
<b>Interior</b>	
• Alcantara door panel inserts in all doors	x
• Door armrests and Center Console in Leather with Premium Stitching	x
• Lower dashboard, glovebox and door trim in Leather with Premium Stitching	x
• Upper dashboard and full door panel in Leather with Premium Stitching, pockets on front seat backs and power seat controls in leather. Available for sold orders only.	sold order option
• Genuine wood inlays in instrument panel, center console and door panels in Brown Polished Walnut, Sycamore, or Beige Birch	x
• Aluminum-design for trim around air vents and MMI display, control unit below central vents, electromechanical parking switch and ring around light switch.	x
• Full length front center console with: - forward storage area and storage area under front center armrest - adjustable rear passenger air vents, rear seat heater controls and rear power outlet	x
• Dual cupholders in front center console	x
• Dual front center armrests, folding and height adjustable with storage capability	x
• Extended rear center console with: - 4-zone climate control - 2 headphone jacks for Rear Seat Entertainment System - 12 V power outlet - storage area Not available with optional 5-seating configuration.	x
• Rear center armrest, folding, with cupholders and first aid kit	x
• Personal refrigerator in pass through to trunk. - Refrigerator with compressor, temperature control range + 50° to - 5° Fahrenheit (+10° to -15° C) - Cooling compartment for 2 x 33 ounce bottles, horizontal (2 x 1 liter) - Additional compartment including 2 glasses (horizontal) - Interior lighting with LED technology Located in pass through instead of ski bag. Retrofitting to ski bag possible. Impact on trunk volume: approx. - 1.1 cu.ft. (- 30 liters) Available from quattro GmbH, sold orders only. Available with 4 or 5 seating configuration.	sold order option
• Bose® Premium 12-speaker sound system with surround sound, subwoofer, center fill speaker and AudioPilot® noise compensation technology	x
• AM/FM radio integrated in MMI with Radio Data System (RDS)	x
• 6-CD changer in glove box	x
• Satellite Radio pre-wiring <sup>2</sup>	x
• Satellite Radio (choice of XM or Sirius) <sup>2</sup>	o
• Diversified (five) antenna in rear window	x
• Audi DVD Navigation System with 7" color screen display and display in driver information display <sup>3</sup>	x
• Rear Seat Entertainment System with 2 displays in front seat headrests, 6 DVD Changer (located in the trunk), remote control, 1 set of headphones, 2 A/V and 2 headphones connections in rear center console.	x
• HomeLink® 3 channel remote transmitter located in headliner console	x
• Backlit electro-luminescent instrument cluster with automatic brightness control including: - tachometer, electronic speedometer, voltmeter, fuel/coolant and oil temperature gauges - digital clock with date - digital odometer and trip odometer	x
• Digital odometer with service interval indicator	x
• Driver information display including: - 8-color LCD display - outside temperature display plus 5-function trip computer - radio display + additional Navigation arrows - active Auto Check system with speed warning device - pictogram display for open door and trunk lid	x
• Immobilizer III anti-theft alarm system with blinking theft-deterrent light in driver's door with tilt sensor	x
• Audi phone preparation with Bluetooth® cellular phone preparation <sup>4</sup> , integrated in MMI. Includes address	x
• Voice control for radio, CD, Navigation and phone	x

<sup>2</sup> Satellite radio is only available in Continental U.S. Activation and first three months of service free of charge.

2006 Audi A8 L W12 quattro  
Equipment

Legend x = Standard      o = Optional      p = Package	A8 L W12 quattro®
<b>Safety</b>	
• Anti-lock braking system (ABS) with vacuum power assist, Electronic Braking-pressure Distribution (EBD), Electronic Differential Lock (EDL), hydraulic Brake Assist, and traction control (ASR)	x
• High-performance aluminum fist-caliper brake system, front brake discs 360 mm diameter with 2 piston calipers, rear discs 310 mm diameter with 1 piston caliper	x
• Electromechanical parking brake lever with emergency brake function	x
• Driver and front passenger dual-stage and dual-threshold next generation airbags supplemental restraint *	x
• Side airbag supplemental restraint for front and rear outboard occupants (seat mounted) *	x
• SIDEGUARD™ head protection airbag supplemental restraints for front and rear occupants	x
• Driver and front passenger knee protection airbags *	x
• Front 3-point safety belts with automatic pretensioning, height adjustable upper mounts and force limiters	x
• Rear 3-point safety belts with automatic pretensioning and angle adjustment	x
• Front passenger side, and rear safety belts with Convertible Locking Retractor (ALR and ELR modes)	x
• Active front head restraints, automatically pivot forward in the event of a rear-end collision	x
• Lower Anchorage and upper Tether Child seat provisions (LATCH) in rear	x
• Child-safety rear door locks	x
• Power central locking system w/safety unlock (unlocks doors & turns on interior lights if airbag deploys)	x
• Active red reflectors in rear of all doors when open	x
• First aid kit in rear center armrest	x
• Trunk release handle in trunk interior	x
• Tire pressure monitoring system	x

■ The Audi Navigation system depends upon signals from the worldwide Global Positioning Satellite network, The vehicle's electrical system, and existing wireless and satellite technologies, must be available and operating properly for the system to function. The mapping does not have the same level of detail in all areas. Periodically, the mapping is updated and a new DVD will be required in order to maintain the latest navigation information. This will be available for purchase from time to time at additional cost. Consult your dealer or call 1-800-FOR-AUDI for details. The Audi Navigation System is designed to provide you with suggested routes in locating addresses, destinations and other points of interest. Changes in street names, construction zones, traffic flow, points of interest or other road system changes are beyond the control of Audi of America, Inc. Complete, detailed mapping of lanes, roads, streets, toll roads, highways, etc., is not possible, therefore you may encounter discrepancies between the mapping and your actual location. Please rely on your individual judgment in determining whether or not to follow a suggested Audi Navigation System route.

■ Your Audi vehicle is equipped with a phone preparation utilizing Bluetooth® interface to enable hands-free functionality (compatible mobile phones sold separately). You will need a Bluetooth enabled mobile phone in order to utilize this function. Not all Bluetooth enabled mobile phone models are compatible with Audi's phone preparation. Visit our web site, [audiusa.com](http://audiusa.com) ([audicanada.ca](http://audicanada.ca)), or contact your local Audi dealer, for the latest listing of compatible phones. Audi recommends the use of the Audi phone cradle (sold separately) with your mobile phone while operating this vehicle.

## 2006 Audi A8 L W12 quattro Option Program



Legend	A8 L W12 quattro®
o = included in package      o = Optional	
<b>Options</b>	
<b>Separate options</b>	
• Adaptive Cruise Control <b>8T4</b>	o
• Solar sunroof - maintains power supply to fan when car is parked in the sun. Replaces glass sunroof. <b>3FR</b>	o
• Satellite radio (choice of XM or Sirius) <b>QU0/ QV8</b> <sup>2</sup>	o
<b>No cost options</b>	
• 18" 5-spoke cast-alloy wheels with all-season tires <b>PRL</b>	o
• Multi-function 4-spoke leather steering wheel in dashboard color, <b>heated</b> , with MMI controls, shift paddles and leather shift knob (available at no cost, replaces wood steering wheel and wood shift knob) <b>2ZD</b>	o
• 5-seating configuration (rear bench) for 3 passengers and 4-way lumbar (replaces individual power rear seats and long center console) <b>5Z0</b>	o
• Front license plate holder (for states which require front license plates) <b>6W3</b>	x
• Front grille filler panel (grille filler with chrome strips for states without front license plate requirement) <b>6W9</b>	o
<b>Separate options "Sold Orders Only" (Items can be ordered on sold orders only)</b>	
• 20" 9-spoke forged alloy wheels with performance tires <sup>1</sup> , 18" temporary spare wheel. <b>Please advise the customer, while this selection of tires delivers responsive handling, they may ride less comfortably and transmit more road noise than other choices.</b> <b>PQU</b>	o
• Full Leather Upgrade (upper dashboard and full door panel in Leather with Premium Stitching, pockets on front seat backs and power seat controls in leather). Available for sold orders only. <b>PL8</b>	o
• Personal refrigerator in pass through to trunk. Available from quattro GmbH, sold orders only. Not available with optional 5 seating configuration. <b>1W7</b>	o



**Personal Refrigerator in pass through**



**Full Leather Upgrade**

- Performance tires are designed for optimum performance and handling in warm climates. They are not suitable for cold, snowy, or icy weather conditions. If you drive under those circumstances, you should equip your vehicle with four all-season or winter tires, which offer better traction under those conditions. We suggest you use the recommended winter or all-season tires specified for your car, or their equivalent. These high-performance tires also have a lower aspect ratio that aids performance and handling; however, in order to avoid tire, rim or vehicle damage, it is important that the inflation pressure is regularly checked and maintained at recommended levels. Serious wheel and tire damage may occur if the vehicle is operated on rough or damaged road surfaces or upon encountering road debris or obstacles. Please also remember in making your selection that, while these tires deliver responsive handling, they may ride less comfortably and make more noise than other choices. Finally, these tires may wear more quickly than other choices. For more information on all of these topics, please consult the owner's manual, your local dealer, or call 1-800-FOR-AUDI.
- Satellite radio is only available in Continental U.S. Activation and first three months of service free of charge.

*Note: For the most up-to-date ordering information, please refer to the latest version of the order guide.*





**12-spoke forged alloy wheels, polished**

8.5J x 19 ET 45

PR # C7G

- Standard
- 255/40 R 19 100 V all-season tires  
- *Pirelli P6 Four Season*

all season tires only

PR # HT2



**Y-spoke cast alloy wheels**

8.5J x 18 ET 45

PR # C3G (delayed availability)

- 255/45 R 18 99 H All-Season Tires:  
- *Conti TouringContact CH 95*  
- *Pirelli P6 Four Seasons*

all season tires only

PR # HT2



**5-spoke cast alloy wheels**

8.5J x 18 ET 45

PR# CG3

- No cost option
- 255/45 R 18 99 H All-Season Tires:  
- *Conti TouringContact CH 95*  
- *Pirelli P6 Four Seasons*

all season tires only

PR# HT2



**9-spoke forged alloy wheels**

9J x 20

PR# CQ2

- Optional
- 275/35 ZR 20 **Performance Tires**<sup>1</sup>  
- *Pirelli P Zero Rosso*  
- *Dunlop Sportmaxx*  
- *Conti Sport Contact 2*

PR# H9N

**Please advise the customer, while this selection of tires delivers responsive handling, they may ride less comfortably and transmit more road noise than other choices.**

(20" wheel receives 18" steel spare)

<sup>1)</sup> Performance tires are designed for optimum performance and handling in warm climates. They are not suitable for cold, snowy, or icy weather conditions. If you drive under those circumstances, you should equip your vehicle with four all-season or winter tires, which offer better traction under those conditions. We suggest you use the recommended winter or all-season tires specified for your car, or their equivalent. These high-performance tires also have a lower aspect ratio that aids performance and handling; however, in order to avoid tire, rim or vehicle damage, it is important that the inflation pressure is regularly checked and maintained at recommended levels. Serious wheel and tire damage may occur if the vehicle is operated on rough or damaged road surfaces or upon encountering road debris or obstacles. Please also remember in making your selection that, while these tires deliver responsive handling, they may ride less comfortably and make more noise than other choices. Finally, these tires may wear more quickly than other choices. For more information on all of these topics, please consult the owner's manual, your local dealer, or call 1-800-FOF AUDI.



**Interior**

Same color program  
as A8 L 4.2 / A8 4.2

E X T E R I O R

	<b>Black</b>	<b>Black / Amaretto</b>	<b>Platinum</b>	<b>Sand Beige</b>	<b>Sand Beige / Cream Beige*</b>
	<b>KA</b>	<b>KR</b>	<b>KF</b>	<b>KV</b>	<b>KW</b>
<b>Brilliant Black</b> A2A2	Available	Available	Available	Available	Available
<b>Light Silver metallic</b> 5B5B	Available	Available	Available	Available	Available
<b>Night Blue pearl effect*</b> 7X7X	N/A	Available	Available	Available	Available
<b>Platinum Beige pearl effect*</b> 7Z7Z	Available	Available	Available	Available	Available
<b>Northern Blue pearl effect</b> 9U9U	Available	Available	Available	Available	Available
<b>Akoya Silver metallic</b> 2S2S	Available	N/A	Available	Available	Available
<b>Oyster Gray metallic*</b> X1X1	Available	Available	Available	Available	Available
<b>Arctic White</b> B5B5	Available	N/A	Available	Available	N/A
<b>Quartz Gray metallic</b> Q4Q4 <b>(NEW)</b>	Available	Available	Available	Available	N/A
<b>Cambridge Green pearl effect*</b> 3W3W	Available	Available	Available	Available	Available

\* sold order only

	<b>Black</b>	<b>Black / Amaretto</b>	<b>Platinum</b>	<b>Sand Beige</b>	<b>Sand Beige / Cream Beige*</b>
	<b>KA</b>	<b>KR</b>	<b>KF</b>	<b>KV</b>	<b>KW</b>
<b>Upper dashboard</b>	Black	Black	Gray	Clay	Clay
<b>Lower dashboard / Carpets / Cargo cover / Hat shelf</b>	Black	Black	Platinum	Sand Beige	Sand Beige
<b>Seats/Door Panels</b>	Black	Amaretto	Platinum	Sand Beige	Cream Beige
<b>Piping / Stitching</b>	Clay	Black	Gray	Clay	Clay
<b>Headliner</b>	Platinum	Amaretto	Platinum	Sand Beige	Cream Beige

2006 Audi A8 L W12 quattro  
Competitors

Technical Specifications		2005 Audi A8 L W12 quattro			
<b>ENGINE:</b>					
Type	DOHC aluminum alloy 15° V-angle and 72° bank angle W12				
Arrangement	Front mounted, longitudinal				
Bore	3.31 in.	84 mm			
Stroke	3.55 in.	90.2 mm			
Displacement	366 cu. in.	5998 cc			
Compression ratio	11.0 : 1				
Fuel requirement	Premium unleaded 91 AKI / 95 RON recommended for maximum performance				
Horsepower (SAE)	450 hp @ 6,200		rpm		
Torque	428 lb.-ft. @ 4,000 - 4,700		rpm		
<b>ENGINE DESIGN:</b>					
Cylinder block	Aluminum silicon alloy (Alusil)				
Crankshaft	Forged, heat-treated steel, 7 bearings, weighing 21.2 kilograms. Crankpins are offset to achieve a constant firing order as on a V6 engine.				
Cylinder head	Aluminum alloy				
Valve train / intake	DOHC, double overhead camshafts driven by a single chain, low-friction roller cam followers, 2 inlet & 2 exhaust valves per cylinder. Infinitely variable timing control for camshafts (52° at inlet and 22° at exhaust valves)				
Firing order	1 - 12 - 5 - 8 - 3 - 10 - 6 - 7 - 2 - 11 - 4 - 9				
Cooling system	Water-cooled, thermostatically controlled radiator fan. Water pump in cylinder block/crankcase, map-controlled electronically controlled continued coolant circulation pump, coolant thermostat, hydraulic fan and electric fan, coolant circulation, and wooter cooled alternator.				
Lubrication system	gear pump, pressure lubrication, full flow through oil cooler				
Fuel injection / Ignition system	Fully electronic engine management utilizing Bosch Motronic® ME7.1.1., sequential injection with electronic throttle control, hot-film air-mass sensing, cylinder selective knock control via 4 sensors and permanent lambda control.				
Emission system	Air gap insulated exhaust manifolds, 4 close-coupled 3-way ceramic catalytic converters, 8 oxygen sensors.				
<b>ELECTRICAL SYSTEM:</b>					
Battery	12 volts	110 amp/hr			
Alternator	14 volts	190 amp			
<b>DRIVETRAIN:</b>					
Transmissions	6-speed Tiptronic transmission				
Type	<b>quattro all-wheel drive</b> <b>6-speed Tiptronic transmission</b>				
Gear ratios:	1st	4.171:1			
	2nd	2.340:1			
	3rd	1.521:1			
	4th	1.143:1			
	5th	0.867:1			
	6th	0.691:1			
	Final Drive	3.317:1			
	Reverse	3.403:1			
Front Differential	Hypoid gear, electronically locking (EDL)				
Center Differential	TORSEN® (TORque SENSing) differential providing automatic and variable front to rear power proportioning				
Rear Differential	Hypoid gear, electronically locking (EDL)				
<b>STEERING:</b>					
Type	Maintenance-free rack-and-pinion steering with Servotronic variable speed-based power assist				
Turns (lock-to-lock)	2.8				
Turning circle (curb-to-curb)	41.7 ft.	12.7 m			
<b>SUSPENSION:</b>					
Fully Pneumatic	Air Suspension Struts at all four wheels. Air Strut damping characteristics are continuously adjusted via sensors. Four driver-activated suspension settings (Dynamic, Standard, Lift, and Automatic)				
<b>BRAKES:</b>					
Service brake	Dual circuit brake system with diagonal split, Anti-lock Brake System (ABS), Electronic Brake Distribution (EBD) and Electronic Stabilization Program (ESP); tandem brake booster				
Front, size and type	15.2 in.	385x36 mm	- Ventilated disc, 2 piston calipers		
Rear, size and type	13.2 in.	335x22 mm	- Ventilated disc, 1 piston caliper		
Parking brake	Electro-mechanically actuated at the rear wheels				
<b>WHEELS:</b>					
	<b>Wheel &amp; Tire Program</b>				
	<b>Standard 19" (C7G)</b>	<b>Optional 20" (CQ2)</b>	<b>No cost 18" (CG3)</b>	<b>Optional 18" (C3G)</b>	<b>delayed availability</b>
Size	8.5J x 19	9J x 20	8.5J x 18	8.5J x 18	
Offset	45 mm	46 mm	45 mm	45 mm	
Weight	11,100 g / 24.5 lbs	14,750 g / 32.5 lbs	12,800 g / 28.2 lbs	n/a	
Type	Forged alloy	Forged alloy	Cast alloy	Cast alloy	
<b>TIRES:</b>					
	<b>Standard 19" (HT2) a/s</b>	<b>Optional 20" (H9N) Perf. <sup>1</sup></b>	<b>No cost 18" (HG7) a/s</b>	<b>18" (HG7) a/s</b>	
Size	255 / 40	275 / 35	255 / 45	255 / 45	
Speed rating	V	Y	H	H	
Construction	Radial	Radial	Radial	Radial	
Load Index	100	102	99	99	
Brand / Type (all approved)	Pirelli P6 Four Season	Pirelli P Zero Rosso	Pirelli P6 Four Seasons	Pirelli P6 Four Seasons	
		Dunlop Sportmaxx	Conti TouringContact Ch 95	Conti TouringContact Ch 95	
		Conti Sport Contact 2			

2006 Audi A8 L W12 quattro  
Competitors

Technical Specifications				2005 Audi A8 L W12 quattro	
<b>BODY:</b>					
Material	Audi Space Frame construction (aluminum alloy) with aluminum alloy body panels				
Corrosion protection	Multi-step anti-corrosion protection				
<b>CAPACITIES:</b>					
Engine oil incl. Filter	13 qt.	12.5 liter			
Fuel tank	23.8 gal.	90 liter			
Cooling system	19.972 qt.	18.9 liter			
<b>EXTERIOR DIMENSIONS:</b>					
Wheelbase	121.0 in.	3074 mm			
Track:	front	63.7 in.	1619 mm		
	rear	63.2 in.	1605 mm		
Overall length	204.4 in.	5192 mm			
Overall width	74.6 in.	1894 mm			
Overall width with mirrors	79.8 in.	2028 mm			
Height (unloaded)	57.3 in.	1455 mm			
Ground clearance (loaded) (variance)	4.72 in.	120 mm	*** Ground clearance is dependent on Suspension Mode setting		
	+/- 1 in.	+/- 25 mm	*** Ground clearance and height is dependent on Suspension Mode setting		
Curb weight	4729 lbs.	2145 kg			
Drag coefficient	Cw = 0.27	Frontal Area = 2.31 sq. m.			
<b>INTERIOR DIMENSIONS (SAE measurements):</b>					
Seating Capacity	4 or 5				
EPA class	Large				
Head room	front	37.4 in.	951 mm	(with sunroof)	
	rear	38.3 in.	974 mm		
Shoulder room	front	59.1 in.	1500 mm		
	rear	57.5 in.	1461 mm		
Leg room	front	41.3 in.	1049 mm		
	rear	42.3 in.	1075 mm		
Interior volume	front	52.8 cu. ft.	1496.7 liters		
	rear	54.0 cu. ft.	1529.9 liters		
	total	121.4 cu. ft.	3439.5 liters		
Luggage Volume (SAE)	14.6 cu. ft.	412.9 liters			
<b>PERFORMANCE:</b>					
0-50 mph (0-80kmh)	3.9 sec.				
0-60 mph (0-100 km/h)	5.0 sec.				
Top speed	Top speed is electronically limited at 130 MPH (209 km/h)				
<b>FUEL ECONOMY (EPA estimate):</b>					
City	15 mpg				
Highway	21 mpg				
Combined	17 mpg				
<b>FUEL ECONOMY: Canadian Estimate</b>					
City	16.0 liters/100km				
Highway	10.5 liters/100km				

<sup>1</sup> Performance tires are designed for optimum performance and handling in warm climates. They are not suitable for cold, snowy, or icy weather conditions. If you drive under those circumstances, you should equip your vehicle with four all-season or winter tires, which offer better traction under those conditions. We suggest you use the recommended winter or all-season tires specified for your car, or their equivalent. These high-performance tires also have a lower aspect ratio that aids performance and handling; however, in order to avoid tire, rim or vehicle damage, it is important that the inflation pressure is regularly checked and maintained at recommended levels. Serious wheel and tire damage may occur if the vehicle is operated on rough or damaged road surfaces or upon encountering road debris or obstacles. Please also remember in making your selection that, while these tires deliver responsive handling, they may ride less comfortably and make more noise than other choices. Finally, these tires may wear more quickly than other choices. For more information on all of these topics, please consult the owner's manual, your local dealer, or call 1-800-FOR-AUDI.



**2006 Audi A8 L W12 quattro  
Competitors**



**MY05 Audi A8 L W12 quattro**

\$117,400 / tbd  
6.0 W12, 4729 lbs.  
450 hp @ 6200 rpm  
428 ft-lbs @ 4000 - 4700 rpm  
All Wheel Drive  
4 or 5 seater available



BMW 760Li

**MY06 BMW 760Li**

\$117,400 / \$118,095\*  
6.0 V12, 4905 lbs.  
438 hp @ 6000 rpm  
444 ft-lbs @ 3950 rpm  
Rear Wheel Drive



BMW 760i

**MY06 BMW 760i**

\$110,000 / \$110,695\*  
6.0 V12, 4762 lbs.  
438 hp @ 6000 rpm  
444 ft-lbs @ 3950 rpm  
Rear Wheel Drive



**MY06 Mercedes S600**

\$127,950 / \$128,725\*  
5.5 V8, 4610 lbs.  
493 hp @ 5000 rpm  
590 ft-lbs @ 1800 - 3500 rpm  
Rear Wheel Drive

\* Includes destination & gas guzzler tax

**Memo:**



**Volkswagen Phaeton**

\$96,100 / \$96,755\*  
6.0 W12, 5399 lbs.  
420 hp @ 6000 rpm  
406 ft-lbs @ 3250 rpm  
All-wheel-drive  
5-seater

**Volkswagen Phaeton**

\$100,800 / \$101,455\*  
6.0 W12, 5399 lbs.  
420 hp @ 6000 rpm  
406 ft-lbs @ 3250 rpm  
All-wheel-drive  
4-seater

## 2006 Audi A8 L W12 quattro Note



A word about this Product Information. Audi of America, Inc., and Audi Canada believe the specifications in this product information to be correct at the time of printing. However, specifications, standard equipment, options and colors are subject to change without notice. Some equipment may be unavailable when your car is built. Please ask your dealer for advice concerning current availability of standard and optional equipment and verify that your car will include the equipment you ordered. Vehicles in this product information are shown with optional equipment. See your dealer for complete details on the Owner Protection Program, Audi Advantage, limited warranty, Audi 24-hour Roadside Assistance program (coverage administered by a third party in the U.S. and Professional Dispatch Group, Welland, Ontario in Canada) and a 12-year limited warranty against corrosion perforation. Tires supplied by various manufacturers. "Audi", "quattro", "A8", "ASF", the four rings and Audi emblems are registered trademarks and "MMI", "Parktronic", and "Sideguard" are trademarks of AUDI AG. "Never Follow" is a registered trademark and "Audi Advanta

\* OnStar uses existing emergency service providers and cellular telephone and satellite technologies. Vehicle's electrical system must be operating for OnStar to work. One year OnStar (Safe & Sound Plan) service agreement included. Call 1-800-ONSTAR-7 or visit [www.onstar.com](http://www.onstar.com) for system limitations and details.

\* To enable hands free function, system requires a hands free phone cradle and appropriate Audi V60 cellular phone. Each sold separately at additional charge. Audi V60 cellular phone activation and subscriptions are the responsibility of the purchaser. Cellular subscriptions, policies and network coverage will vary by carrier. Consult your carrier for

\* Audi vehicles are equipped with a telematics system that utilizes analog telephone signals to enable Audi Telematics by OnStar services. Recently, the U.S. Federal Communications Commission (FCC) ruled that wireless telephone carriers are required to fully support the analog wireless network until February 16, 2008. After this date, it is likely that the analog wireless network will be phased out, rendering analog devices inoperable.

\* Owners of Audi vehicles equipped with analog telematics systems will be offered normal Audi Telematics by OnStar services through December 31, 2007. After this date, and because of the expected phase out of the analog wireless network, Audi Telematics by OnStar services cannot be offered to owners of Audi vehicles equipped with analog telematics systems.

Performance tires are designed for optimum performance and handling in warm climates. They are not suitable for cold, snowy, or icy weather conditions. If you drive under those circumstances, you should equip your vehicle with four all-season or winter tires, which offer better traction under those conditions. We suggest you use the recommended winter or all-season tires specified for your car, or their equivalent. These high-performance tires also have a lower aspect ratio that aids performance and handling; however, in order to avoid tire, rim or vehicle damage, it is important that the inflation pressure is regularly checked and maintained at recommended levels. Serious wheel and tire damage may occur if the vehicle is operated on rough or damaged road surfaces or upon encountering road debris or obstacles. Please also remember in making your selection that, while these tires deliver responsive handling, they may ride less comfortably and make more noise than other choices. Finally, these tires may wear more quickly than other choices. For more information on all of these topics, please consult the owner's manual, your local dealer, or call Satellite radio is only available in Continental U.S. Activation and first three months of service free of charge.

The Audi Navigation system depends upon signals from the worldwide Global Positioning Satellite network, The vehicle's electrical system, and existing wireless and satellite technologies, must be available and operating properly for the system to function. The mapping does not have the same level of detail in all areas. Periodically, the mapping is updated and a new DVD will be required in order to maintain the latest navigation information. This will be available for purchase from time to time at additional cost. Consult your dealer or call 1-800-FOR-AUDI for details.

Your Audi vehicle is equipped with a phone preparation utilizing Bluetooth® interface to enable hands-free functionality (compatible mobile phones sold separately). You will need a Bluetooth enabled mobile phone in order to utilize this function. Not all Bluetooth enabled mobile phone models are compatible with Audi's phone preparation. Visit our web site, [audiusa.com](http://audiusa.com) ([audicanada.ca](http://audicanada.ca)), or contact your local Audi dealer, for the latest listing of compatible phones. Audi recommends the use of the Audi phone cradle (sold separately) with your mobile phone while operating this vehicle.