

korando



korando
Stylish Performer

 SSANGYONG

MODERN URBAN APPEAL

The New Korando features trendy new styling inside and out, and performance has been upgraded as well to maximise your satisfaction with this exciting compact SUV.

You'll be proud to be seen in this classy compact utility vehicle, which is fun to drive and looks terrific about town.

PROUDLY NEW ZEALAND OWNED

SsangYong New Zealand and all our SsangYong dealers are 100% NZ owned and operated.



GIUGIARO DESIGN

The latest generation Korando was redesigned by celebrated Italian Automobile Designer Giorgetto Giugiaro. Giugiaro won various prominent design awards and in 1999 was named Designer of the Century. This Korando was developed for dynamic driving on road and off road and has become a true urban SUV.



25 Watt HD Head lamps



Radiator grille



Fog lamps



Puddle lamp



Tail lamp assembly



Rear spoiler

A STYLING MAKE-OVER THAT STRESSES DYNAMISM AND REFINEMENT

The mesh radiator grille has been made slimmer and wider, and is complemented by the mesh air intake grille. The LED daytime running lights / positioning lamps and projection headlamps add elegance while the black finish on the lower part of the bumper completes the assertive, modern look.

The round fog lamps contrast with the forceful front bumper.

Side repeaters have been mounted on the outside mirrors, and a puddle lamp is attached to the bottom of each outside mirror to assist with vehicular entry and egress in the dark.



HIGH-END FEATURES TO ENHANCE EFFICIENCY, COMFORT AND FUN

The trip computer keeps track of travel distance and fuel consumption, and the 2-din audio system (Sport model) supports MP3, CDs, Bluetooth hands-free, the iPod / iPhone connectivity and radio data system (RDS).

The interior appearance has been upgraded, too. The new fabric seat covers are more luxurious, wearing a new pattern and woven with a double stitch. In black the seat covers are both functional and fashionable, and the woodgrain panelling now has a matte finish.



Trip computer

Flat floor in back



Reclining seats

Heated front seats (selected models)



Multimedia system with 7" display



Bluetooth hands-free and audio functions



HDMI terminal for a portable device, connectable to the 7" colour display



Reversing rear view camera (Selected models)



Bluetooth hands-free



Electronic Eco-cruise control

PERFORMANCE NOW BETTER THAN EVER

The New Korando comes with two engine options, a powerful and efficient 2 litre diesel engine or a 2 litre petrol model. All comply with Europe's Euro-5 emissions standards, and are remarkably quiet in operation, thanks to constant innovation and improvement.

The e-XDi200 diesel produces high torque at the low-end for better fuel efficiency and NVH performance. The cylinder block and heads are made of light, high-strength metal, while a single-belt system minimises slippage and vibration. The e-XGi200 petrol performs at its peak in the low to medium speed range. The crankshaft offset, open deck cylinder block, and low-friction technology enhance eco-friendliness.

The Aisin automatic transmission provides prompt gear shifting and smooth driving.



e-XGi200 Petrol
109.6 kW (197Nm) 1,998cc

e-XDi200 Diesel
129 kW (360Nm) 1,998cc



6-speed automatic transmission

Thumbs-up manual switch with 6-speed automatic



THE LATEST ELECTRONICS & HIGH-END MECHANICS

The New Korando is loaded with an array of advanced systems to promote operational safety and economy as well as greater comfort for all occupants. The Electronic Stability Programme (ESP) is the platform on which are added the Hill Start Assist (HAS), and Emergency Stop Signal (ESS) features. Meanwhile, the all-wheel drive system is electronically controlled and includes a 4WD lock mode.

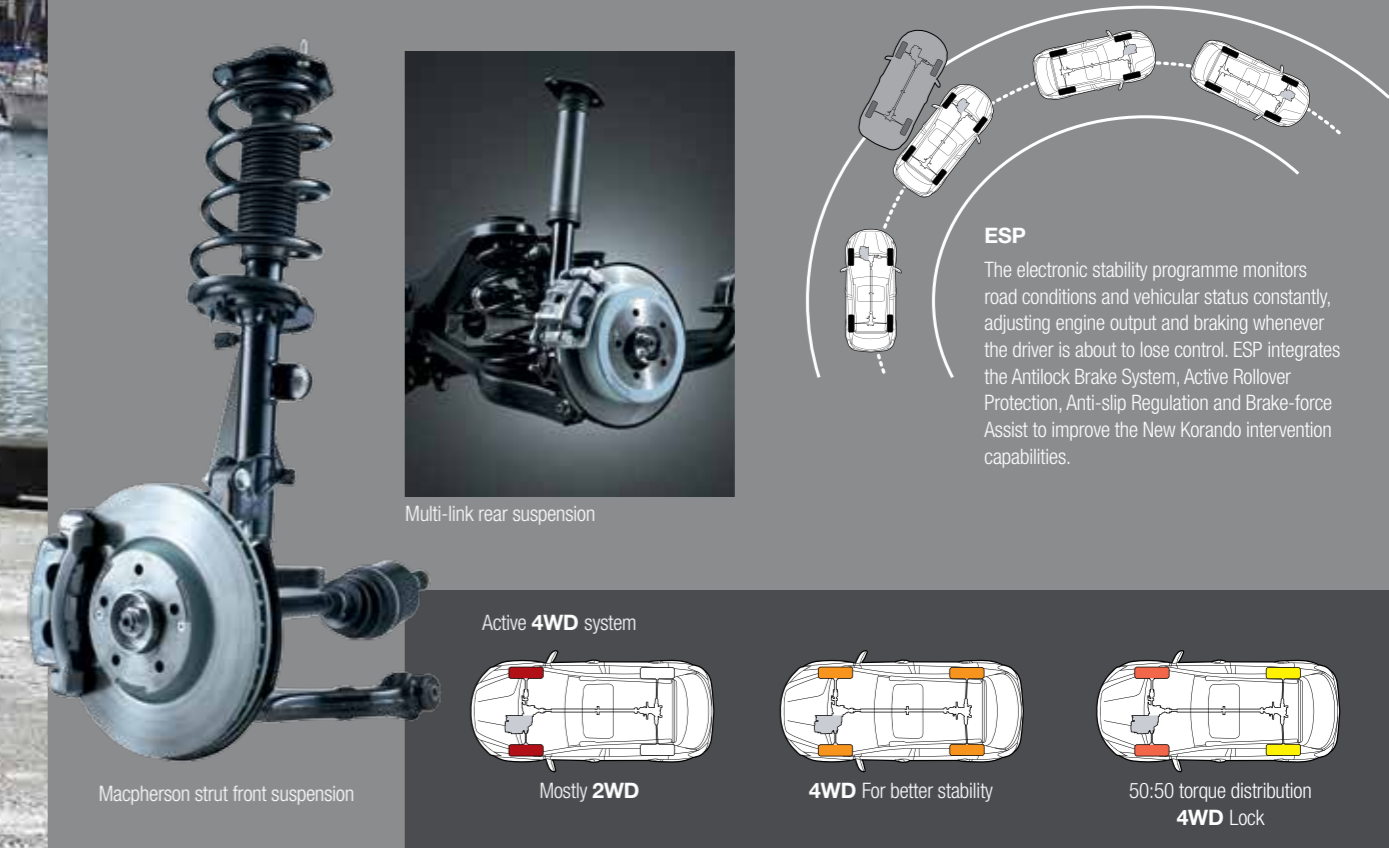

Macpherson strut front suspension



Multi-link rear suspension

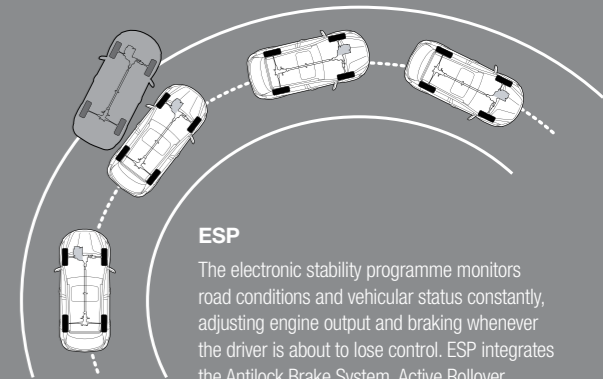

ESP

The electronic stability programme monitors road conditions and vehicular status constantly, adjusting engine output and braking whenever the driver is about to lose control. ESP integrates the Antilock Brake System, Active Rollover Protection, Anti-slip Regulation and Brake-force Assist to improve the New Korando intervention capabilities.

Active 4WD system

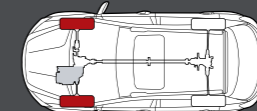

Mostly 2WD

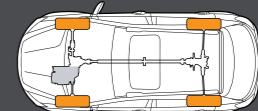

4WD For better stability

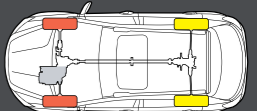

50:50 torque distribution
4WD Lock

VERSATILITY, THE NAME OF THE GAME

The New Korando has the flexibility to support everyday transportation needs as well as weekend leisure trips.

The 2nd row seats can be partially or fully folded flat depending on the load to be carried. The cargo bay is the largest for this SUV segment and the optimised interior layout provides the most possible legroom as well as

wide and comfortable seating in the rear.



2nd row folded flat 40% (814 litre capacity)



2nd row folded flat 60% (984 litre capacity)



2nd row folded flat 100% (1,312 litre capacity)



Normal seating (486 litre capacity)



IMPROVED SAFETY

In the Limited and SPR models, a total of six airbags are now deployed, including two front and two side airbags in the 1st row and a pair of curtain airbags that cover both the 1st and 2nd rows. The front airbag on the front passenger's side can be deactivated, and its presence is now completely hidden behind an attractively covered panel. All seats come equipped with head-rests, and ISO-FIX brackets for securing for a child's seat in the 2nd row.



Head-rest



ISO-FIX for child seat



Built-in 3 point centre seatbelt



Invisible passenger airbag

EXTERIOR



Full-bodied bonnet character line



Privacy and solar glass*



Windscreen wiper de-icer



Useful roof rails*



Chrome style package



Chrome radiator grille*



Tailgate detailing



Stainless steel door scuff



Dual tailpipes



Chrome door handle

Powered outside mirrors

INTERIOR



Standard cluster*



Remote control switches on steering wheel



2-din audio system with MP3, CD layer and iPod/iPhone connector (with RDS)*



Multi-function control switches



HDMI and USB Ports/Aux. port with USB Ports (iPod/iPhone connector)



Sunglasses case



Console front tray



Rear view mirror



Folding key



CONVENIENCE



Glove box



Automatic/manual climate control*



Cup holders in the front



Luggage cover*



Cup holders in the rear



Centre console options



Panic alarm



Quick and even heating and cooling



Rear obstacle warning system with 3-stage alarm

COLOUR GUIDE AND WHEELS



Sunrise Red

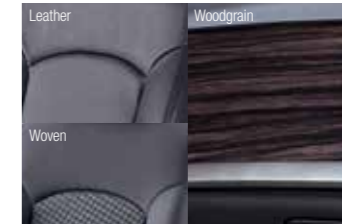

Black interior



Carbonic Grey



Red interior



Space Black

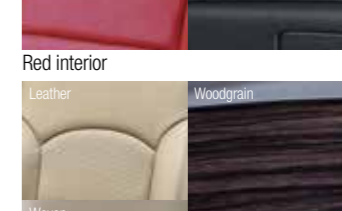

Biege interior



Silent Silver



Grand White



18" alloy wheels (diamond cut)



16" alloy wheels

FEATURES LIST

	Petrol 2WD Sport	Petrol 2WD Limited	Petrol 2WD SPR	Petrol AWD SPR	Diesel AWD SPR
MECHANICAL					
149ps 2.0L e-XGi petrol engine	•	•	•	•	
175ps 2.0L eXDi diesel engine with CDPF					•
Active AWD with lock mode				•	•
6-speed automatic transmission with Thumbs-up manual mode	•	•	•	•	•
Macpherson strut front suspension	•	•	•	•	•
Multi-link rear suspension	•	•	•	•	•
Hydraulic power steering	•	•	•	•	•
APPEARANCE					
All-around tinted glass		•	•	•	•
Fashionable roof rails		•	•	•	•
Sporty air spoiler with LED high mounted stop lamp		•	•	•	•
Acoustic engine cover to dampen noise	•	•	•	•	•
18" diamond cut alloy wheels			•	•	•
16" alloy wheels	•	•			
Full-size spare tyre	•	•	•	•	•
Illuminated ignition key slot	•	•	•	•	•
Luxurious leather steering wheel trim		•	•	•	•
Floor mats	•	•	•	•	•
Welcoming light to illuminate the ground area	•	•	•	•	•
Height adjustable headlights with clear turn signal lamp Level adjustable 25 Watt HID (High Intensity Discharge) headlights			•	•	
Rear combination lamp with LED light guide	•	•	•	•	•
Two-toned lower mouldings	•	•	•	•	•
Chrome-plated dual tail pipes	•	•	•	•	•
Body-coloured exterior door handles	•	•	•	•	•
Hybrid blade wipers	•	•	•	•	•
Chrome inside door handle	•	•	•	•	•
Stainless steel front & rear door scuff	•	•	•	•	•
Deluxe chrome speaker grille	•	•	•	•	•
CONVENIENCE					
Super vision instrument cluster				•	•
LED side repeater on exterior mirror	•	•	•	•	•
Battery saver to ensure power reserve	•	•	•	•	•
Electronic Eco-cruise control	•	•	•	•	•

	Petrol 2WD Sport	Petrol 2WD Limited	Petrol 2WD SPR	Petrol AWD SPR	Diesel AWD SPR
2-din audio system with MP3, CD player and iPod / iPhone connector (with RDS)	•				
7" high-resolution touch screen with audio streaming and link to rearview camera and smart phone		•	•	•	•
USB memory slot and Aux. port	•				
Aux. port and HDMI port		•	•	•	•
Bluetooth hands-free	•	•	•	•	•
Pole antenna on the rear roof	•	•	•	•	•
Windshield wiper de-icer	•	•	•	•	•
One-touch triple signal indicators	•	•	•	•	•
Heated tailgate window	•	•	•	•	•
Folding key type remote keyless entry system with panic alarm	•	•	•	•	•
Six speakers including 2 tweeters for high level sound	•	•	•	•	•
Steering wheel audio system controls	•	•	•	•	•
Dual spray type washer nozzles	•	•	•	•	•
Trip computer with outside temperature indicator	•	•	•	•	•
12V DC power outlets under the instrument panel (deluxe console) and in the load area	•	•	•	•	•
Outside mirrors that can be electrically adjusted, folded and heated	•	•	•	•	•
Mobile ashtray	•	•	•	•	•
Digital clock	•	•	•	•	•
Dual gas filled tailgate struts	•	•	•	•	•
Centre storage console	•	•	•	•	•
Grip on the inside of the tailgate to facilitate closing	•	•	•	•	•
Cup holders in the front and rear	•	•	•	•	•
Sun visors with illuminated vanity mirror	•	•	•	•	•
Luggage cover and net				•	•
Useful toolbox in the load area	•	•	•	•	•
Electronic tailgate opening release switch	•	•	•	•	•
Manual tilt steering wheel	•	•	•	•	•
Luggage tray	•	•	•	•	•
SAFETY					
High integrated semi frame monocoque body structure	•	•	•	•	•
Door impact beams for optimal protection from side collisions	•	•	•	•	•
Driver airbag and invisible passenger airbag with seatbelt load limiters and pretensioner	•	•	•	•	•

	Petrol 2WD Sport	Petrol 2WD Limited	Petrol 2WD SPR	Petrol AWD SPR	Diesel AWD SPR
Curtain airbags for front and rear passengers			•	•	•
Side airbags for front passengers			•	•	•
Emergency Stop Signal (ESS)	•	•	•	•	•
4-channel Anti-lock Braking System (ABS)	•	•	•	•	•
Rear obstacle warning system with 3-stage alarm			•	•	•
Electronic Stability Program (ESP) with Emergency Brake Assist, Hill Start Assist (HSA) and Active Roll-over Protection (ARP)	•	•	•	•	•
Front ventilated disc brakes	•	•	•	•	•
Rear disc brakes	•	•	•	•	•
Door courtesy lamps	•	•	•	•	•
Heightened security from an immobilizer system	•	•	•	•	•
Rear wiper and washer	•	•	•	•	•
Hand-operated parking brake	•	•	•	•	•
Childproof safety door locks	•	•	•	•	•
Automatic speed-sensing door locks	•	•	•	•	•
Reminder alarm and speed-sensing feature for front passenger seatbelts	•	•	•	•	•
Built-in 3-point's rear centre seatbelt	•	•	•	•	•
ISO-FIX and tether anchorage for child seat	•	•	•	•	•

SEATS					
Pumping height adjustable driver's seat	•	•	•	•	•
60:40 split folding 2nd row seats with folding centre armrest	•	•	•	•	•
Luxurious leather seat upholstery				•	•
Appealing woven cloth seat upholstery	•	•			
Heated front seats			•	•	•

CLIMATE CONTROL					
Fully automatic air conditioning with temperature sensor and digital display				•	•
Manual air conditioning with maximum air conditioning function	•	•	•		
Rear heating duct to enhance climate control effectiveness	•	•	•	•	•
Positive temperature coefficient (PTC) heater	•	•	•	•	•

* Some of features may be optional or not be available according to market. Please, contact your local dealer for the exact details regarding vehicles sold in your area.

TECHNICAL DATA

		2WD SPORT	2WD LIMITED	2WD SPR	AWD SPR	AWD SPR	
ENGINE		PETROL 2.0L					
DRIVEN WHEELS		2WD			AWD	AWD	
TRANSMISSION		6AT					
EMISSION		Euro 5	Euro 5	Euro 5	Euro 5	Euro 5	
EXTERIOR DIMENSION	Overall Length	mm		4,410			
	Overall width	mm		1,830			
	Overall height	mm		1,675 (1,710 with roof rack)			
	Tread	Front	mm		1,573		
		Rear	mm		1,558		
	Overhang	Front	mm		920		
		Rear	mm		840		
	Wheelbase	mm		2,650			
	Minimum clearance	mm		180			
	Min turning radius	m		5.4			
WEIGHT	Gross vehicle weight	kg		2,100	2,170	2,260	
	Kerb weight	kg		1,545~1,599		1,625~1,680	
	Gross trailer weight	Braked	kg		1,500		
		Unbraked	kg		750		
ENGINE	Fuel	-			Petrol		
	Capacity	cc		1,998			
	Bore X Stroke	mm		86 X 86			
	Compression ratio	-		10.5 : 1			
	Number of cylinders	-		4 in-line			
PERFORMANCE	Max. power	kW/rpm		109.6 / 6,000		129 / 4,000	
		ps/rpm		149 / 6,000		175 / 4,000	
	Max. torque	Nm/rpm		197 / 4,000		360 / 2,000~3,000	
		kg.m/rpm		20.1 / 4,000		36.7 / 2,000~3,000	
Max.speed	km/h		165				
FUEL CONSUMPTION	CO2 (combined)	g/km		185	198	199	
	Combined	L/100km		7.96		7.5	
	Extra urban	L/100km		6.61		6.3	

DIMENSIONS

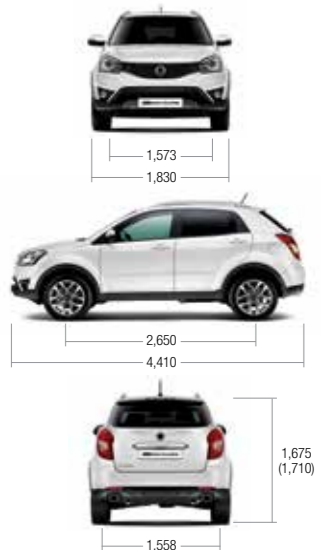

- The fuel economy can vary according to road conditions or driver's habits.
- The above technical data can vary slightly by regional certification requirements or sales specifications.
- The petrol figures are based on the Euro 5 standard.
- The diesel figures are based on the Euro 5 standard.