

1963 CORVAIR MODELS AND INDEX TO MODEL INFORMATION

900 SERIES (Series Features . . . pages 2-3)

- Corvair 900 Monza 4-Door Sedan (5-Passenger).....
- Corvair 900 Monza Club Coupe (2-Door 4-Passenger).....
- Corvair 900 Monza Convertible (2-Door 4-Passenger).....
- Monza Spyder Equipment (Club Coupe and Convertible).....

700 SERIES (Series Features . . . pages 12-13)

- Corvair 700 4-Door Sedan (6-Passenger).....
- Corvair 700 Club Coupe (2-Door 5-Passenger).....

500 SERIES (Series Features . . . pages 18-19)

- Corvair 500 Club Coupe (2-Door 5-Passenger).....

CORVAIR GREENBRIER (Series Features . . . pages 22-23)

- Greenbrier Sports Wagon (6-Door 6-Passenger).....
- Greenbrier De Luxe Sports Wagon.....
- Greenbrier Special Custom Features.....

POWER TEAMS . . . pages 30-35, BODY FEATURES . . . pages 36-37 and 40-41, CHASSIS SPECIFICATIONS . . . pages 38-39 and 42-43, OPTIONS AND ACCESSORIES . . . pages 44-45

MODEL NO.	PAGE
969	4-5
927	6-7
967	8-9
927-967	10-11
769	14-15
727	16-17
527	20-21
R1206	24-25
R1206 W/RPO Z60	26
	27-29

CORVAIR 900 MONZA MODELS

- 4-DOOR SEDAN
 - CLUB COUPE
 - CONVERTIBLE
- AND ... MONZA SPYDER

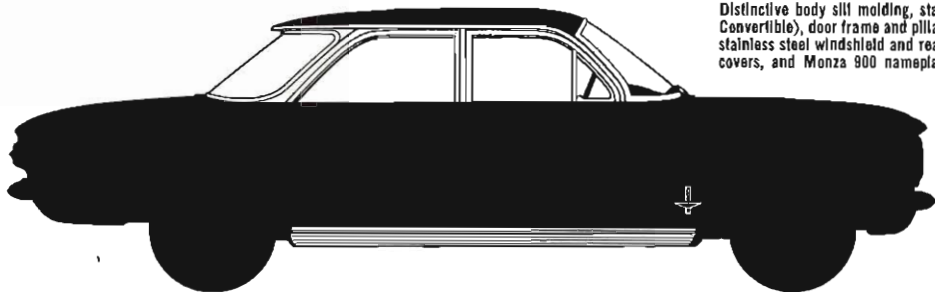

Distinctive body sill molding, stainless steel drip cap molding (except Convertible), door frame and pillar moldings on Sedan and Club Coupe, stainless steel windshield and rear window reveal moldings, full wheel covers, and Monza 900 nameplate and emblem on front fender.



Simulated dual vents below rear window, bright-metal license plate recess opening framing, anodized aluminum engine air grille, deck lid nameplate, and twin-unit taillights and back-up lights.

Monza 900 front fender nameplate and emblem.

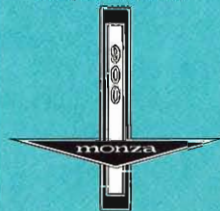

Monza 900 stainless steel full wheel covers.

SERIES FEATURES (in addition to or replacing Corvair 700 or 500 equipment)

- Distinctive exterior trim and ornamentation
- Stainless steel full wheel covers
- Extra-quality interior features and appointments
- Ultra-luxurious all-vinyl color-keyed interiors
- Foam-cushioned front bucket seats
- Convenient fold-down rear seat (except Convertible)
- Color-keyed deep-twist carpet floor covering



Ultra-luxurious color-keyed Monza 900 Interiors . . . Individual foam-cushioned front bucket seats with bright aluminum seat end panels, all-vinyl seat upholstery, embossed vinyl headlining, all-vinyl door insert trim panel with bright accent molding, dual-arm styled door opening and window regulator handles, vinyl covered front door armrests, rear armrests with built-in ashtrays on Sedan and Convertible, convenient fold-down rear seat (except on Convertible), and deep-twist carpet floor covering.



Deluxe dual-spoke steering wheel with chromed half-circle horn ring . . . color-keyed to interiors. Instrument panel features include cigarette lighter, ashtray, chrome-capped control knobs, anodized aluminum instrument cluster facing and molding, anodized aluminum glove compartment door facing and molding, glove compartment lock and light, and Monza 900 nameplate and emblem.

PLUS . . . ALL THESE CORVAIR QUALITY FEATURES

- Monostrut Body by Fisher
- Magic-Mirror acrylic lacquer finish
- High-Level ventilation system
- Built-in forced-air heater and defroster system
- Single-key lock system
- Adjustable sun visors
- Friction-type ventipanes
- Enclosed steering column
- Directional signals with twin indicator lights in instrument cluster
- Locking front luggage compartment
- Parallel-action electric windshield wipers
- Unipack power team—rear mounted engine and transaxle
- Quadri-Flex 4-wheel independent suspension
- Self-adjusting air-cooled Safety-Master brakes
- Extended-life exhaust system
- Low-friction Ball-Race steering
- Statically balanced wheels and tires
- Four-unit headlights with anodized aluminum frames
- Deep-section wrap-around bumpers
- Push-button type outside door handles
- Front door and luggage compartment weather-shielded key locks

CORVAIR MONZA 4-DOOR SEDAN

4-DOOR 5-PASSENGER

MODEL 969



MONZA 4-DOOR SEDAN FEATURES

- Smart sedan styling with distinctive roof and rear window design
- Wide-opening 4-door convenience and easy entrance
- Ultra-luxurious all vinyl interior with front bucket seats
- Distinctive body sill moldings
- Twin-unit taillights and back-up lights with anodized aluminum bezels
- Simulated dual vents below rear window
- Monza series front fender nameplate and emblem
- Bright rear license plate recess opening frame
- Stainless steel full wheel covers
- Additional bright metal moldings and accents: windshield, rear window, roof drip cap, ventipane frames, door frames, pillar moldings, front grille panel molding, front nameplate and emblem, deck lid nameplate, engine air grille.

INTERIOR FEATURES AND APPOINTMENTS

- Ultra-luxurious all-vinyl color-keyed upholstery
- Embossed vinyl headlining
- Vinyl-covered adjustable sun visors
- Combination ribbed vinyl and tufted leather-grain vinyl sidewall trim insert panels
- Color-keyed deep-twist carpet floor covering
- Individual foam-cushioned front bucket seats
- Fold-down rear seat
- Bright metal instrument cluster facing and molding
- Bright metal glove compartment door facing and molding
- Identifying Monza glove compartment door nameplate and emblem
- Cigarette lighter
- Glove compartment lock
- Glove compartment light
- De luxe dual-spoke steering wheel with chromed half-circle horn ring—two-toned except with red, black, white and saddle interiors (dual horns)
- Bright metal backed rearview mirror
- Color-keyed front and rear armrests with bright finished bases
- Lift-out ashtrays in instrument panel and rear armrests
- Two coat hooks
- Bright aluminum front seat outer end panels
- Central dome light with chromed bezel and instrument panel main light switch control
- Automatic front door dome light switches
- Friction-type ventipanes
- Dual-styled door opening and window regulator handles
- Foam-backed fabric front luggage compartment mat
- Lined interior stowage compartment behind rear seat

TRIM AND COLOR SELECTIONS

INTERIOR	RPO NUMBERS AND EXTERIOR COLORS*		
	SOLID		
RPO 758 Fawn	900—Tuxedo Black 905—Laurel Green 908—Ivy Green	920—Autumn Gold 922—Ember Red 934—Cordovan Brown	936—Ermine White 938—Adobe Beige 948—Palomar Red
RPO 755 Aqua	900—Tuxedo Black 918—Azure Aqua	919—Marine Aqua 936—Ermine White	940—Satin Silver
RPO 781 Red	900—Tuxedo Black 920—Autumn Gold 922—Ember Red	936—Ermine White 938—Adobe Beige	940—Satin Silver 948—Palomar Red
RPO 732 Blue	900—Tuxedo Black 912—Silver Blue	914—Monaco Blue 936—Ermine White	940—Satin Silver
RPO 705 Saddle	900—Tuxedo Black 920—Autumn Gold 922—Ember Red	932—Saddle Tan 934—Cordovan Brown	936—Ermine White 938—Adobe Beige
RPO 712 Black	900—Tuxedo Black 905—Laurel Green 912—Silver Blue 918—Azure Aqua	920—Autumn Gold 922—Ember Red 932—Saddle Tan 936—Ermine White	938—Adobe Beige 940—Satin Silver 948—Palomar Red
RPO 727 White	900—Tuxedo Black 922—Ember Red	936—Ermine White 940—Satin Silver	948—Palomar Red

*Two-tone colors not available

SPECIFICATIONS

Wheel/base	108.0
Length (overall)	180.0
Height (loaded)	51.5
Road clearance (min.)	6.0
Tread: Front	54.5
Rear	54.5
Width (overall)	67.0
Interior Room:	Front Rear
Torso room	37.5 36.5
Leg room	40.5 34.0
Hip room	58.5 58.0
Shoulder room	54.0 53.5
Entrance height	29.0 29.0
Luggage Compartment:	
Loading height	27.0
Total volume (cu. ft.)	12.6
Usable luggage space (cu. ft.)	6.6
Inside luggage space—rear seat folded (cu. ft.)	16.5
Total glass area (sq. in.)	3381.7
Windshield area (sq. in.)	1122.8
Rear window area (sq. in.)	1104.2
Tire size	6.50 x 13
Turning Diameter: (feet)	
Curb-to-curb	R—38.3, L—37.9
Wall-to-wall	R—40.5, L—40.0
Steering ratio (overall)	23.5:1
Fuel tank capacity (gallons)	14
Weight: (lbs.)	
Curb	2540
Shipping	2450

POWER TEAMS	pages 30-33
BODY FEATURES	pages 36-37
CHASSIS SPECIFICATIONS	pages 38-39
OPTIONS AND ACCESSORIES	pages 44-45

CORVAIR MONZA CLUB COUPE

2-DOOR 4-PASSENGER

MODEL 927

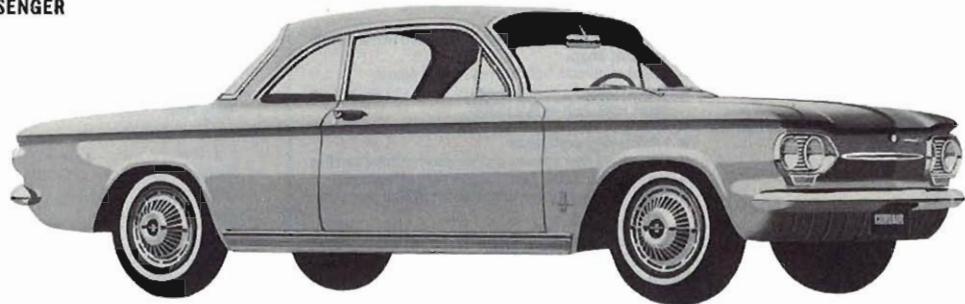

MONZA CLUB COUPE FEATURES

- Distinctive roof and rear window design
- Wide-opening 2-door convenience and easy entrance
- Ultra-luxurious all vinyl interior with front bucket seats
- Distinctive body sill moldings
- Twin-unit taillights and back-up lights with anodized aluminum bezels
- Simulated dual vents below rear window
- Monza series front fender nameplate and emblem
- Bright rear license plate recess opening frame
- Stainless steel full wheel covers
- Additional bright metal moldings and accents: windshield, rear window, roof drip cap, ventipane frames, door frame, center pillar, quarter window frame, front grille panel molding, front nameplate and emblem, deck lid nameplate, and engine air grille.

INTERIOR APPOINTMENTS AND FEATURES

- Ultra-luxurious all-vinyl color-keyed seat upholstery
- Embossed vinyl headlining
- Vinyl-covered adjustable sun visors
- Combination ribbed vinyl and tufted leather-grain vinyl sidewall trim insert panels
- Color-keyed deep-twist carpet floor covering
- Individual foam-cushioned front bucket seats with folding backrests
- Fold-down rear seat
- Bright metal instrument cluster facing and molding
- Bright metal glove compartment door facing and molding
- Identifying Monza glove compartment door nameplate and emblem
- Cigarette lighter

- Glove compartment lock
- Glove compartment light
- De luxe dual-spoke steering wheel with chromed half-circle horn ring—two-toned except with red, black, white and saddle interiors (dual horns)
- Bright metal backed rearview mirror
- Color-keyed front armrests with bright finished bases
- Lift-out ashtrays in instrument panel and rear quarter
- Two coat hooks
- Bright aluminum front seat outer end panels
- Central dome light with chromed bezel and instrument panel main light switch control
- Automatic front door dome light switches
- Friction-type ventipanes
- Dual-styled door opening and window regulator handles
- Foam-backed fabric front luggage compartment mat

TRIM AND COLOR SELECTIONS

INTERIOR	RPO NUMBERS AND EXTERIOR COLORS*		
	SOLID		
RPO 758 Fawn	900—Tuxedo Black 905—Laurel Green 908—Ivy Green	920—Autumn Gold 922—Ember Red 934—Cordovan Brown	936—Ermine White 938—Adobe Beige 948—Palomar Red
RPO 755 Aqua	900—Tuxedo Black 918—Azure Aqua	919—Marine Aqua 936—Ermine White	940—Satin Silver
RPO 781 Red	900—Tuxedo Black 920—Autumn Gold 922—Ember Red	936—Ermine White 938—Adobe Beige	940—Satin Silver 948—Palomar Red
RPO 732 Blue	900—Tuxedo Black 912—Silver Blue	914—Monaco Blue 936—Ermine White	940—Satin Silver
RPO 705 Saddle	900—Tuxedo Black 920—Autumn Gold 922—Ember Red	932—Saddle Tan 934—Cordovan Brown	936—Ermine White 938—Adobe Beige
RPO 712 Black	900—Tuxedo Black 905—Laurel Green 912—Silver Blue 918—Azure Aqua	920—Autumn Gold 922—Ember Red 932—Saddle Tan 936—Ermine White	938—Adobe Beige 940—Satin Silver 948—Palomar Red
RPO 727 White	900—Tuxedo Black 922—Ember Red	936—Ermine White 940—Satin Silver	948—Palomar Red

*Two-tone colors not available

SPECIFICATIONS

Wheelbase	108.0
Length (overall)	180.0
Height (loaded)	51.5
Road clearance (min.)	6.0
Tread: Front	54.5
Rear	54.5
Width (overall)	67.0
Interior Room:	Front Rear
Torso room	37.5 37.0
Leg room	40.5 32.5
Hip room	58.5 57.0
Shoulder room	54.0 52.0
Entrance height	28.5 —
Luggage Compartment:	
Loading height	27.0
Total volume (cu. ft.)	12.6
Usable luggage space (cu. ft.)	6.6
Inside luggage space—rear seat folded (cu. ft.)	16.5
Total glass area (sq. in.)	3219.2
Windshield area (sq. in.)	1122.8
Rear window area (sq. in.)	1069.2
Tire size	6.50 x 13
Turning Diameter: (feet)	
Curb-to-curb	R—38.3, L—37.9
Wall-to-wall	R—40.5, L—40.0
Steering ratio (overall)	23.5:1
Fuel tank capacity (gallons)	14
Weight: (lbs.)	
Curb	2500
Shipping	2415

POWER TEAMS	pages 30-35
BODY FEATURES	pages 36-37
CHASSIS SPECIFICATIONS	pages 38-39
OPTIONS AND ACCESSORIES	pages 44-45

CORVAIR MONZA CONVERTIBLE

2-DOOR 4-PASSENGER

MODEL 967



MONZA CONVERTIBLE FEATURES

- Low, luxurious open-air styling
- Wide-opening 2-door convenience and easy entrance
- Ultra-luxurious all-vinyl interior with front bucket seats
- Manually operated vinyl-coated fabric counterbalanced folding top*
- Distinctive body sill moldings
- Twin-unit taillights and back-up lights with anodized aluminum bezels
- Simulated dual vents below rear window
- Monza series front fender nameplate and emblem
- Bright license plate recess opening frame
- Stainless steel full wheel covers
- Additional bright metal moldings and accents: windshield, windshield header and pillars, ventipane frames, quarter window glass forward edge, rear belt molding, front grille panel molding, front nameplate and emblem, deck lid nameplate, and engine air grille.

*Power operated folding top optional at extra cost

INTERIOR APPOINTMENTS AND FEATURES

- Ultra-luxurious all-vinyl color-keyed upholstery
- Combination ribbed vinyl and tufted leather-grain vinyl sidewall trim insert panels
- Vinyl-covered adjustable sun visors
- Color-keyed deep-twist carpet floor covering
- Individual foam-cushioned bucket front seats with folding backrests
- Bright metal instrument cluster facing and molding
- Bright metal glove compartment door facing and molding
- Identifying Monza glove compartment door nameplate and emblem
- Cigarette lighter
- Glove compartment lock

- Glove compartment light
- De luxe dual-spoke steering wheel with chromed half-circle horn ring—two-toned except with red, black, white and saddle interiors (dual horns)
- Bright metal backed rearview mirror
- Color-keyed front door armrests with bright-finish bases and built-in rear armrests
- Lift-out ashtrays in instrument panel and rear armrests
- Bright aluminum front seat outer end panels
- Dual courtesy lights with instrument panel main light switch control
- Automatic front door courtesy light switches
- Friction-type ventipanes
- Dual-styled door opening and window regulator handles
- Foam-backed fabric front luggage compartment mat

TRIM AND COLOR SELECTIONS

INTERIOR	RPO NUMBERS AND EXTERIOR COLORS*		
	SOLID		
RPO 758 Fawn	900—Tuxedo Black 905—Laurel Green 908—Ivy Green	920—Autumn Gold 922—Ember Red 934—Cordovan Brown	936—Ermine White 938—Adobe Beige 948—Palomar Red
RPO 755 Aqua	900—Tuxedo Black 918—Azure Aqua	919—Marine Aqua 936—Ermine White	940—Satin Silver
RPO 781 Red	900—Tuxedo Black 920—Autumn Gold 922—Ember Red	936—Ermine White 938—Adobe Beige	940—Satin Silver 948—Palomar Red
RPO 732 Blue	900—Tuxedo Black 912—Silver Blue	914—Monaco Blue 936—Ermine White	940—Satin Silver
RPO 705 Saddle	900—Tuxedo Black 920—Autumn Gold 922—Ember Red	932—Saddle Tan 934—Cordovan Brown	936—Ermine White 938—Adobe Beige
RPO 712 Black	900—Tuxedo Black 905—Laurel Green 912—Silver Blue 918—Azure Aqua	920—Autumn Gold 922—Ember Red 932—Saddle Tan 936—Ermine White	938—Adobe Beige 940—Satin Silver 948—Palomar Red
RPO 727 White	900—Tuxedo Black 922—Ember Red	936—Ermine White 940—Satin Silver	948—Palomar Red

CONVERTIBLE TOP COLORS

White standard . . . Black (RPO C05-A) and Beige (RPO C05-B) optional at no extra cost with all exterior colors

*Two-tone colors not available.

SPECIFICATIONS

Wheelbase	108.0
Length (overall)	180.0
Height (loaded)	51.5
Road clearance (min.)	6.00
Tread: Front	54.5
Rear	54.5
Width (overall)	67.0
Interior Room:	Front Rear
Torso room	38.0 38.0
Leg room	40.5 31.5
Hip room	58.5 47.5
Shoulder room	54.0 44.0
Entrance height	28.0 —
Luggage Compartment:	
Loading height	27.0
Total volume (cu. ft.)	12.6
Usable luggage space (cu. ft.)	6.6
Total glass area (sq. in.)	2872.9
Windshield area (sq. in.)	1122.8
Rear window area (sq. in.)	726.6
Tire size	6.50 x 13
Turning Diameter: (feet) Curb-to-curb	R—38.3, L—37.9
Wall-to-wall	R—40.5, L—40.0
Steering ratio (overall)	23.5:1
Fuel tank capacity (gallons)	14
Weight: (lbs.)	
Curb	2610
Shipping	2525

POWER TEAMS	pages 30-35
BODY FEATURES	pages 36-37
CHASSIS SPECIFICATIONS	pages 38-39
OPTIONS AND ACCESSORIES	pages 44-45

MONZA 900 CLUB COUPE AND CONVERTIBLE SPYDER EQUIPMENT

MODEL 927

MODEL 967



RPO L87—SPYDER EQUIPMENT OPTION*

(In addition to or replacing regular Monza 900 equipment—RPO G95 3.55:1 rear axle required additional equipment)

MONZA SPYDER FEATURES

- Special Monza Spyder 150-hp Turbocharged 145 engine with power-boosting exhaust-driven turbo-supercharger
- Exclusive exterior identification . . . Spyder nameplate on front fenders and distinctive identifying emblem on rear deck lid below Chevrolet nameplate
- Special Monza Spyder instrument cluster with tachometer, manifold pressure and cylinder head temperature gauges, and 120-mph speedometer with trip odometer
- Distinctive steering wheel and glove compartment door identifying nameplates and emblems

*Optional at extra cost

MONZA SPYDER SPECIAL FEATURES

Monza Spyder instrument panel features include special steering wheel hub emblem, stainless steel instrument cluster and glove compartment door facing, distinctive glove compartment door nameplate and emblem, and special Spyder instrument arrangement in addition to regular Monza de luxe features.

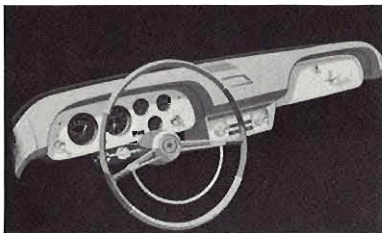

Special Spyder instruments include 6,000-rpm electric tachometer, 120-mph speedometer with convenient trip odometer, manifold pressure gauge indicating supercharger operation, and cylinder head temperature gauge and buzzer signal alarm in addition to regular engine temperature warning light.

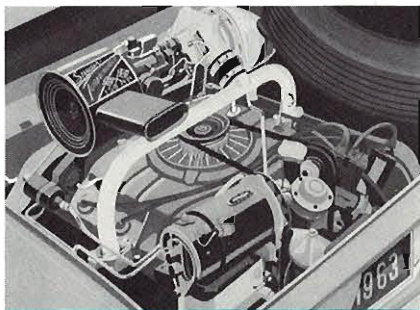

Bright engine compartment accents include chromed fuel induction tube, fuel and oil lines, oil dipstick, throttle linkage and tailpipe, and polished stainless steel tire heat shield.

SPECIFICATIONS

Club Coupe and Convertible except as indicated		
Wheelbase		108.0
Length (overall)		180.0
Height (loaded)		51.5
Road Clearance (min.)		6.0
Tread:	Front 54.5 Rear 54.5	
Width (overall)		67.0
Interior Room:		Front Rear
Torso room—Club Coupe		37.5 37.0
—Convertible		38.0 38.0
Leg room—Club Coupe		40.5 32.5
—Convertible		40.5 31.5
Hip room—Club Coupe		58.5 57.0
—Convertible		58.5 47.5
Shoulder room—Club Coupe		54.0 52.0
—Convertible		54.0 44.0
Entrance height—Club Coupe		28.5 —
—Convertible		28.0 —
Luggage Compartment:		
Loading height		27.0
Total volume (cu. ft.)		12.6
Usable luggage space (cu. ft.)		6.6
Total glass area (sq. in.)—Club Coupe		3219.2
—Convertible		2872.9
Windshield area (sq. in.)		1122.8
Rear window area (sq. in.)—Club Coupe		1059.2
—Convertible		726.6
Tire size:		6.50 x 13
Turning Diameter: (feet)		
Curb-to-curb		R—38.3, L—37.9
Wall-to-wall		R—40.5, L—40.0
Steering Ratio: (overall)		25.4:1
Fuel tank capacity (gallons)		14
Weight: (lbs.)		
Curb—Sport Coupe		2500
—Convertible		2510
Shipping—Sport Coupe		2415
—Convertible		2525

POWER TEAMS	pages 30-31 & 34-35
BODY FEATURES	pages 36-37
CHASSIS SPECIFICATIONS	pages 38-39
OPTIONS AND ACCESSORIES	pages 44-45

For Trim and Color Selections
See pages 7 and 9, Corvair section.

CORVAIR 700 MODELS

- 4-DOOR SEDAN
- CLUB COUPE

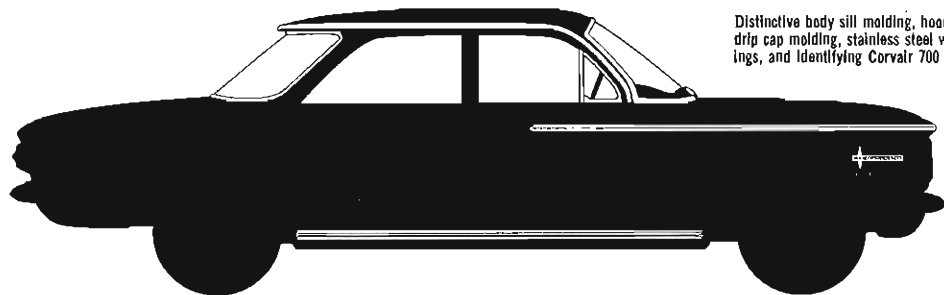

Distinctive body sill molding, hood and body side moldings, stainless steel drip cap molding, stainless steel windshield and rear window reveal moldings, and identifying Corvaair 700 nameplate and emblem on front fender.



Combination stop, tail, and directional lights with anodized aluminum bezels, anodized aluminum back-up light cover plates (cover plates removed with optional back-up lights installed), deck lid nameplate, and anodized aluminum engine air grille.

Corvaair 700 front fender nameplate and emblem.



SERIES FEATURES (in addition to or replacing Corvair 500 equipment)

- Distinctive exterior trim
- Luxurious color-keyed interiors
- Extra-quality interior features and appointments
- Color-keyed vinyl-coated rubber floor covering
- Foam-backed fabric front luggage compartment mat



Luxurious color-keyed Corvair 700 interiors . . . foam-cushioned front seats trimmed in pattern cloth and leather-grain vinyl, embossed vinyl headlining, all-vinyl door insert panel trim with bright accents, single-arm styled door opening and window regulator handles, vinyl-covered front door armrests, and vinyl-coated rubber floor covering.



Dual spoke steering wheel with chromed horn button . . . color-keyed to interiors. Instrument panel features include cigarette lighter, ashtray, chrome-capped control knobs, instrument cluster and glove compartment door anodized aluminum facing, glove compartment lock, and Corvair 700 nameplate and emblem.

PLUS . . . ALL THESE CORVAIR QUALITY FEATURES

- Monostrut Body by Fisher
- Magic-Mirror acrylic lacquer finish
- High-Level ventilation system
- Built-in forced-air heater and defroster system
- Single-key lock system
- Adjustable sun visors
- Friction-type ventpanes
- Enclosed steering column
- Directional signals with twin indicator lights in instrument cluster
- Locking front luggage compartment
- Parallel-action electric windshield wipers
- Unipack power team—rear mounted engine and transaxle
- Quadri-Flex 4-wheel independent suspension
- Self-adjusting air-cooled Safety-Master brakes
- Extended-life exhaust system
- Low-friction Ball-Race steering
- Statically balanced wheels and tires
- Four-unit headlights with anodized aluminum frames
- Deep-section wrap-around bumpers
- Push-button type outside door handles
- Front door and luggage compartment weather-shielded key locks

CORVAIR 700 4-DOOR SEDAN

4-DOOR 6-PASSENGER

MODEL 769



CORVAIR 700 4-DOOR SEDAN FEATURES

- Smart sedan styling with distinctive roof and rear window design
- Wide-opening 4-door convenience and easy entrance
- Luxurious color-keyed interior
- Hood and body side moldings
- Distinctive body sill moldings
- Single-unit taillights with anodized aluminum bezels
- Anodized aluminum back-up light* opening cover plates
- Corvair 700 series front fender nameplate and emblem
- Stainless steel hub caps (optional full wheel covers illustrated)
- Additional bright metal moldings and accents: windshield, rear window, roof drip cap, ventipane frames, front grille panel molding, front nameplate and emblem, deck lid nameplate, and engine air grille.

*Back-up lights optional at extra cost

INTERIOR APPOINTMENTS AND FEATURES

- Luxurious pattern cloth and leather-grain vinyl color-keyed seat upholstery
- Embossed vinyl headlining
- Dual adjustable sun visors
- All-vinyl sidewall trim insert panels with bright vinyl molding
- Color-keyed vinyl-coated rubber floor covering
- Foam-cushioned front seat
- Bright metal instrument cluster facing
- Bright metal glove compartment door facing
- Identifying Corvair 700 glove compartment door nameplate
- Cigarette lighter
- Dual-spoke steering wheel with chromed center button horn control (dual horns)

- Glove compartment lock
- Adjustable rearview mirror
- Color-keyed front armrests
- Two coat hooks
- Central dome light with instrument panel main light switch control
- Automatic front door dome light switches
- Friction-type ventipanes
- Single-arm styled door opening and window regulator handles
- Foam-backed fabric front luggage compartment floor mat
- Lined interior stowage compartment behind rear seat

TRIM AND COLOR SELECTIONS

INTERIOR	RPD NUMBERS AND EXTERIOR COLORS		
	SOLID		TWO-TONE
RPO 757 Fawn	900—Tuxedo Black 905—Laurel Green 908—Ivy Green 920—Autumn Gold 922—Ember Red	932—Saddle Tan 934—Cordovan Brown 936—Ermine White 938—Adobe Beige 948—Palomar Red	950—Ermine White & Tuxedo Black 954—Ermine White & Laurel Green 970—Adobe Beige & Autumn Gold 971—Adobe Beige & Saddle Tan 972—Adobe Beige & Cordovan Brown 973—Ermine White & Ember Red
RPO 751 Aqua	900—Tuxedo Black 918—Azure Aqua 919—Marine Aqua	936—Ermine White 940—Satin Silver	950—Ermine White & Tuxedo Black 963—Ermine White & Azure Aqua 967—Azure Aqua & Marine Aqua 984—Ermine White & Satin Silver
RPO 780 Red	900—Tuxedo Black 920—Autumn Gold 922—Ember Red 936—Ermine White	938—Adobe Beige 940—Satin Silver 948—Palomar Red	950—Ermine White & Tuxedo Black 970—Adobe Beige & Autumn Gold 973—Ermine White & Ember Red 984—Ermine White & Satin Silver
RPO 731 Blue	900—Tuxedo Black 912—Silver Blue 914—Monaco Blue	936—Ermine White 940—Satin Silver	950—Ermine White & Tuxedo Black 959—Ermine White & Silver Blue 962—Silver Blue & Monaco Blue 984—Ermine White & Satin Silver

SPECIFICATIONS

Wheelbase	108.0
Length (overall)	180.0
Height (loaded)	51.5
Road clearance (min.)	6.0
Tread: Front	54.5
Rear	54.5
Width (overall)	67.0
Interior Room:	Front Rear
Torso room	37.5 36.5
Leg room	41.5 34.0
Hip room	58.5 58.0
Shoulder room	54.0 53.5
Entrance height	29.0 27.5
Luggage Compartment:	
Loading height	27.0
Total volume (cu. ft.)	12.6
Usable luggage space (cu. ft.)	6.6
Total glass area (sq. in.)	3381.7
Windshield area (sq. in.)	1122.8
Rear window area (sq. in.)	1104.2
Tire size	6.50 x 13
Turning Diameter: (feet) Curb-to-curb	R—38.3, L—37.9
Wall-to-wall	R—40.5, L—40.0
Steering ratio (overall)	23.5:1
Fuel tank capacity (gallons)	14
Weight: (lbs.)	
Curb	2470
Shipping	2385

POWER TEAMS	pages 30-33
BODY FEATURES	pages 36-37
CHASSIS SPECIFICATIONS	pages 38-39
OPTIONS AND ACCESSORIES	pages 44-45

CORVAIR 700 CLUB COUPE

2-DOOR 5-PASSENGER

MODEL 727

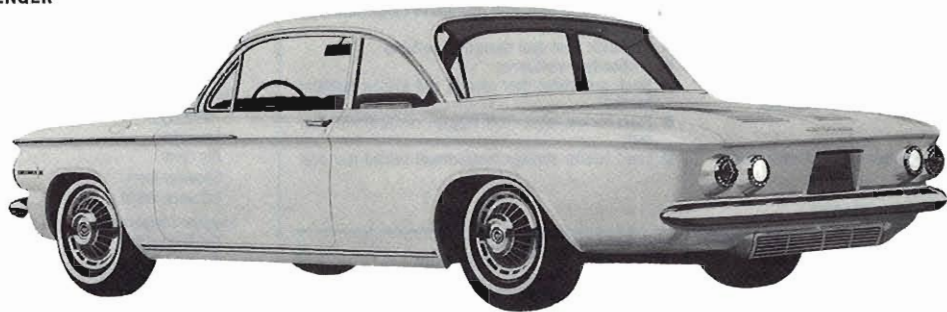

CORVAIR 700 CLUB COUPE FEATURES

- Distinctive roof and rear window design, roll-down rear quarter windows
- Wide-opening 2-door convenience and easy entrance
- Luxurious color-keyed interior
- Hood and body side moldings
- Distinctive body sill moldings
- Single-unit taillights with anodized aluminum bezels
- Anodized aluminum back-up light* opening cover plates
- Corvair 700 series front fender nameplate and emblem
- Stainless steel hub caps (optional full wheel covers illustrated)
- Additional bright metal moldings and accents: windshield, rear window, roof drip cap, ventipane frames, front grille panel molding, front nameplate and emblem, deck lid nameplate, and engine air grille

*Back-up lights optional at extra cost

INTERIOR APPOINTMENTS AND FEATURES

- Luxurious pattern cloth and leather-grain vinyl color-keyed seat upholstery
- Embossed vinyl headlining
- Dual adjustable sun visors
- All-vinyl sidewall trim insert panels with bright vinyl molding
- Color-keyed vinyl-coated rubber floor covering
- Foam-cushioned front seat
- Full-width front seat with folding backrests
- Bright metal instrument cluster facing
- Bright metal glove compartment door facing
- Identifying Corvair 700 glove compartment door nameplate
- Cigarette lighter
- Dual-spoke steering wheel with chromed center button horn control (dual horns)
- Glove compartment lock
- Adjustable rearview mirror
- Color-keyed front armrests
- Two coat hooks
- Central dome light with instrument panel main light switch control
- Automatic front door dome light switches
- Friction-type ventipanes
- Single-arm styled door opening and window regulator handles
- Foam-backed fabric front luggage compartment floor mat

TRIM AND COLOR SELECTIONS

INTERIOR	RPO NUMBERS AND EXTERIOR COLORS		
	SOLID		TWO-TONE
RPO 757 Fawn	900—Tuxedo Black 905—Laurel Green 908—Ivy Green 920—Autumn Gold 922—Ember Red	932—Saddle Tan 934—Cordovan Brown 936—Ermine White 938—Adobe Beige 948—Palomar Red	950—Ermine White & Tuxedo Black 954—Ermine White & Laurel Green 970—Adobe Beige & Autumn Gold 971—Adobe Beige & Saddle Tan 972—Adobe Beige & Cordovan Brown 973—Ermine White & Ember Red
RPO 751 Aqua	900—Tuxedo Black 918—Azure Aqua 919—Marine Aqua	936—Ermine White 940—Satin Silver	950—Ermine White & Tuxedo Black 963—Ermine White & Azure Aqua 967—Azure Aqua & Marine Aqua 984—Ermine White & Satin Silver
RPO 780 Red	900—Tuxedo Black 920—Autumn Gold 922—Ember Red 936—Ermine White	938—Adobe Beige 940—Satin Silver 948—Palomar Red	950—Ermine White & Tuxedo Black 970—Adobe Beige & Autumn Gold 973—Ermine White & Ember Red 984—Ermine White & Satin Silver
RPO 731 Blue	900—Tuxedo Black 912—Silver Blue 914—Monaco Blue	936—Ermine White 940—Satin Silver	950—Ermine White & Tuxedo Black 959—Ermine White & Silver Blue 962—Silver Blue & Monaco Blue 984—Ermine White & Satin Silver

SPECIFICATIONS

Wheelbase	108.0
Length (overall)	180.0
Height (loaded)	51.5
Road clearance (min.)	6.0
Tread: Front	54.5
Rear	54.5
Width (overall)	67.0
Interior Room:	Front Rear
Torso room	37.5 36.5
Leg room	41.5 32.5
Hip room	58.5 57.0
Shoulder room	54.0 52.0
Entrance height	29.0 —
Luggage Compartment:	
Loading height	27.0
Total volume (cu. ft.)	12.6
Usable luggage space (cu. ft.)	6.6
Total glass area (sq. in.)	3219.2
Windshield area (sq. in.)	1122.8
Rear window area (sq. in.)	1069.2
Tire size	6.50 x 13
Turning Diameter: (feet)	
Curb-to-curb	R—38.3, L—37.9
Wall-to-wall	R—40.5, L—40.0
Steering ratio (overall)	23.5:1
Fuel tank capacity (gallons)	14
Weight: (lbs.)	
Curb	2440
Shipping	2355

POWER TEAMS	pages 30-33
BODY FEATURES	pages 36-37
CHASSIS SPECIFICATIONS	pages 38-39
OPTIONS AND ACCESSORIES	pages 44-45

CORVAIR 500 MODEL

■ CLUB COUPE

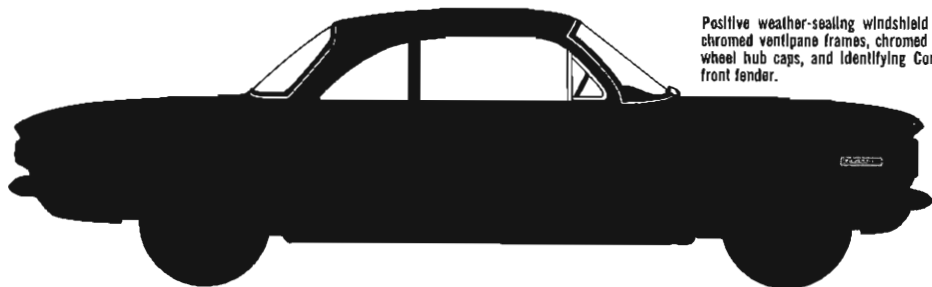

Positive weather-sealing windshield and rear window rubber moldings, chromed ventplane frames, chromed door opening handles, stainless steel wheel hub caps, and identifying Corvair 500 nameplate and emblem on front fender.



Combination stop, tail, and directional lights with anodized aluminum bezels, anodized aluminum back-up light cover plates (cover plate removed with optional back-up lights installed), deck lid nameplate and anodized aluminum engine air grille.

Corvair 500 front fender nameplate and emblem.



SERIES FEATURES

- Distinctive exterior trim
- Quality interior features and appointments
- Smartly styled color-keyed interiors
- Durable black rubber floor covering

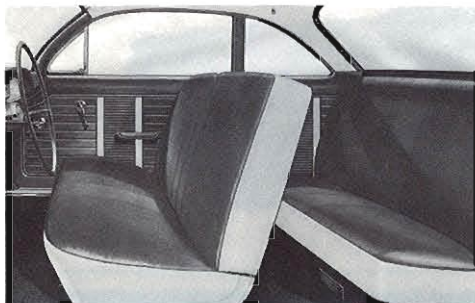

Distinctive color-keyed Corvair 500 Interiors . . . foam-cushioned front seat, combination ribbed and leather-grain vinyl seat upholstery, embossed vinyl headlining, all-vinyl door insert panel trim, single-arm styled door opening and window regulator handles, vinyl-covered front door armrests, central dome light with convenient instrument panel main light switch control, and black rubber mat floor covering.

PLUS . . . ALL THESE CORVAIR QUALITY FEATURES

- Monostrut Body by Fisher
- Magic-Mirror acrylic lacquer finish
- High-Level ventilation system
- Built-in forced-air heater and defroster system
- Single-key lock system
- Adjustable sun visors
- Friction-type ventipanes
- Enclosed steering column
- Directional signals with twin indicator lights in instrument cluster
- Locking front luggage compartment
- Parallel-action electric windshield wipers
- Unipack power team—rear mounted engine and transaxle
- Quadri-Flex 4-wheel independent suspension
- Self-adjusting air-cooled Safety-Master brakes
- Extended-life exhaust system
- Low-friction Ball-Race steering
- Statically balanced wheels and tires
- Four-unit headlights with anodized aluminum frames
- Deep-section wrap-around bumpers
- Pushbutton type outside door handles
- Front door and luggage compartment weather-shielded key locks



Dual spoke steering wheel with chromed horn button . . . color-keyed to interiors. Instrument panel features include cigarette lighter, ashtray, chrome-capped control knobs, instrument cluster anodized aluminum facing, glove compartment lock, and bright-painted glove compartment door.

CORVAIR 500 CLUB COUPE

2-DOOR 5-PASSENGER

MODEL 527



CORVAIR 500 CLUB COUPE FEATURES

- Distinctive roof and rear window design, stationary rear quarter windows
- Wide-opening 2-door convenience and easy entrance
- Smartly styled color-keyed all-vinyl interior
- Single-unit taillights with anodized aluminum bezels
- Anodized aluminum back-up light* opening cover plates
- Corvair 500 series front fender nameplate and emblem
- Stainless steel hub caps
- Additional bright metal moldings and accents: ventipane frames, front grille panel molding, front nameplate and emblem, deck lid nameplate, and engine air grille

*Back-up lights optional at extra cost

INTERIOR APPOINTMENTS AND FEATURES

- Color-keyed ribbed vinyl and leather-grain vinyl seat upholstery
- Embossed vinyl headlining
- Dual adjustable sun visors
- Combination ribbed vinyl and leather-grain vinyl sidewall trim insert panels
- Black rubber mat floor covering
- Foam-cushioned front seat
- Full-width front seat with folding backrests
- Bright metal instrument cluster facing
- Cigarette lighter
- Bright painted glove compartment door
- Glove compartment lock
- Dual-spoke steering wheel with chromed center button horn control (single horn)
- Adjustable rearview mirror
- Color-keyed front armrests
- Two coat hooks
- Central dome light with instrument panel main light switch control
- Friction-type ventpanes
- Single-arm styled door opening and window regulator handles
- Gray-white spatter pattern painted front luggage compartment

TRIM AND COLOR SELECTIONS

INTERIOR	RPO NUMBERS AND EXTERIOR COLORS		
	SOLID		TWO-TONE
RPO 764 Fawn	900—Tuxedo Black 905—Laurel Green 908—Ivy Green 912—Silver Blue 914—Monaco Blue 920—Autumn Gold	922—Ember Red 932—Saddle Tan 934—Cordovan Brown 936—Ermine White 938—Adobe Beige 948—Palomar Red	950—Ermine White & Tuxedo Black 954—Ermine White & Laurel Green 959—Ermine White & Silver Blue 962—Silver Blue & Monaco Blue 970—Adobe Beige & Autumn Gold 971—Adobe Beige & Saddle Tan 972—Adobe Beige & Cordovan Brown 973—Ermine White & Ember Red
RPO 720 Aqua	900—Tuxedo Black 918—Azure Aqua 919—Marine Aqua	936—Ermine White 940—Satin Silver	950—Ermine White & Tuxedo Black 963—Ermine White & Azure Aqua 967—Azure Aqua & Marine Aqua 984—Ermine White & Satin Silver
RPO 783 Red	900—Tuxedo Black 920—Autumn Gold 922—Ember Red 936—Ermine White	938—Adobe Beige 940—Satin Silver 948—Palomar Red	950—Ermine White & Tuxedo Black 970—Adobe Beige & Autumn Gold 973—Ermine White & Ember Red 984—Ermine White & Satin Silver

SPECIFICATIONS

Wheelbase.....	108.0	
Length (overall).....	180.0	
Height (loaded).....	51.5	
Road clearance (min.).....	6.0	
Tread: Front.....	54.5	Rear..... 54.5
Width (overall).....	67.0	
Interior Room:	Front	Rear
Torso room.....	37.5	36.5
Leg room.....	41.5	32.5
Hip room.....	58.5	57.0
Shoulder room.....	54.0	52.0
Entrance height.....	29.0	—
Luggage Compartment:		
Loading height.....	27.0	
Total volume (cu. ft.).....	12.6	
Usable luggage space (cu. ft.).....	6.6	
Total glass area (sq. in.).....	3207.7	
Windshield area (sq. in.).....	1122.8	
Rear window area (sq. in.).....	1069.2	
Tire Size.....	6.50 x 13	
Turning Diameter: (feet)		
Curb-to-curb.....	R—38.3,	L—37.9
Wall-to-wall.....	R—40.5,	L—40.0
Steering Ratio: (overall).....	23.5:1	
Fuel tank capacity (gallons).....	14	
Weight: (lbs.)		
Curb.....	2420	
Shipping.....	2330	

POWER TEAMS.....	pages 30-33
BODY FEATURES.....	pages 36-37
CHASSIS SPECIFICATIONS.....	pages 38-39
OPTIONS AND ACCESSORIES.....	pages 44-45

GREENBRIER MODELS

- GREENBRIER SPORTS WAGON
- GREENBRIER DE LUXE SPORTS WAGON

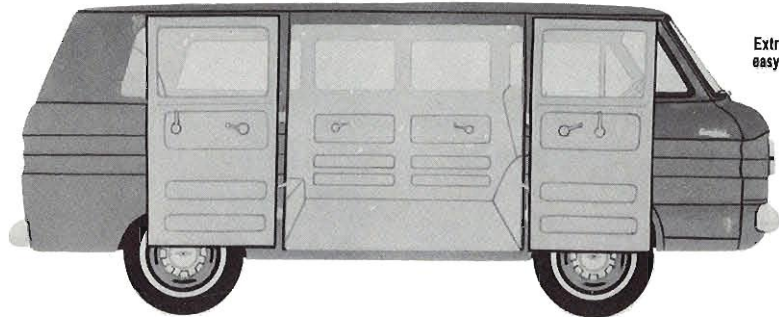

Extra-large right-side double door openings and low step height for easy loading or entrance. Left-side double doors optional at extra cost.



Big wide-opening double rear doors offer easy access to rear cargo floor and can be fully opened for close-up loading. Hinged panel below rear doors permits quick access to engine for periodic maintenance and inspection.

Greenbrier
by CHEVROLET 

Greenbrier front door nameplate

SERIES FEATURES

- Large-capacity passenger and cargo carrying van-type design
- Six wide-opening doors for easy entrance and loading
- Extra-large, easily accessible cargo space
- Smartly styled and appointed interiors
- Foam-cushioned seat cushions

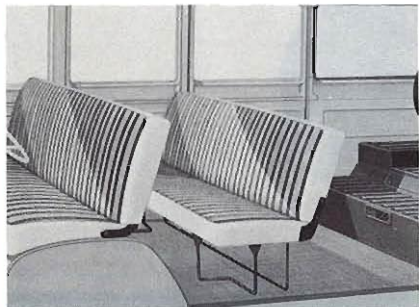

Smartly styled Greenbrier interior . . . foam-cushioned full-width seats, pattern cloth and leather-grain vinyl seat upholstery, color-keyed painted sidewalls, vinyl-coated headlining between roof bows, single-arm styled door opening and window regulator handles, adjustable sliding left-hand sun visor, central dome light, and charcoal-color ribbed rubber floor covering. Adjustable front seat features special adjustable backrest for greater driving comfort. Versatile second seat is easily removed for greater cargo capacity, faces either to the front or rearward in the forward position (illustrated), or can be moved to rearward position facing front. Third seat for greater seating capacity optional at extra cost. For Greenbrier De Luxe additional features—see page 26, Corvair section.

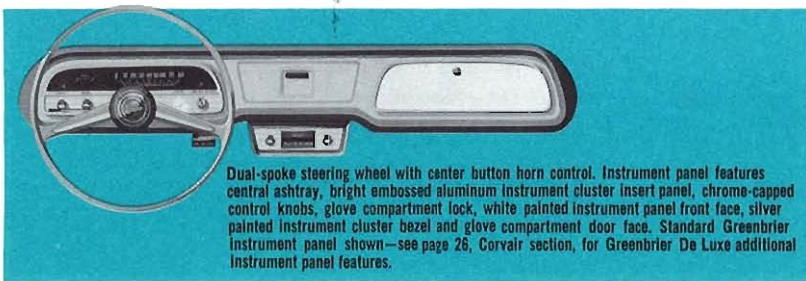

Dual-spoke steering wheel with center button horn control. Instrument panel features central ashtray, bright embossed aluminum instrument cluster insert panel, chrome-capped control knobs, glove compartment lock, white painted instrument panel front face, silver painted instrument cluster bezel and glove compartment door face. Standard Greenbrier instrument panel shown—see page 26, Corvair section, for Greenbrier De Luxe additional instrument panel features.

PLUS . . . ALL THESE QUALITY FEATURES

- Fully unitized body construction
- High-quality synthetic enamel finish
- High-Level ventilation system
- Single-key lock system
- Friction-type ventipanes
- Enclosed steering column
- Directional signals with twin indicator lights in instrument cluster
- Parallel-action electric windshield wipers
- Unipack power team—rear mounted engine and transaxle
- Quadri-Flex 4-wheel independent suspension
- Self-adjusting air-cooled Safety-Master brakes
- Extended-life exhaust system
- Low-friction Ball-Race steering
- Statically balanced wheels and tires
- Anodized aluminum front air intake grille
- Four-unit headlights with anodized aluminum frames
- Twin high-mounted combination parking lights and directional signal lights
- Pushbutton type outside door handles
- Front, side, and rear door weather-shielded key locks

CORVAIR GREENBRIER SPORTS WAGON

6-DOOR 6-PASSENGER

MODEL R1206



GREENBRIER SPORTS WAGON FEATURES

- Distinctively low van-type styling
- Wide-opening left and right front, double right side and double rear doors for convenient loading and easy entrance
- Smartly styled and appointed interior
- Full-width adjustable front seat cushion and backrest
- Versatile 3-position removable second seat
- Extra-large cargo compartment with low load floor
- Painted hub caps and bumpers
- Single-unit styled stop, tail, and directional signal lights
- Bright metal accents: anodized aluminum front air intake grille with Chevrolet nameplate and emblem, anodized aluminum head-lamp and parking lamp frames, Greenbrier series nameplate on front doors, Corvair nameplate on rear door

INTERIOR FEATURES AND APPOINTMENTS

- Medium fawn pattern cloth and textured vinyl seat upholstery
- Adjustable left-hand sun visor
- Charcoal color ribbed rubber floor covering
- Medium fawn color painted sidewalls
- Fawn-colored vinyl-coated jute headlining between roof bows
- Foam-cushioned full-width seat cushions
- Removable, 3-position second seat
- Bright embossed instrument cluster insert panel

- Central ashtray on instrument panel
- Glove compartment lock
- Dual-spoke steering wheel with center horn button
- Central dome light with instrument panel main light switch control
- Friction-type ventpanes
- Roll-down front door and side windows (except rear quarter windows)
- Adjustable front seat with adjustable backrest
- Single-arm styled door opening and window regulator handles

TRIM AND COLOR SELECTIONS

GREENBRIER

INTERIOR	EXTERIOR COLORS
Fawn	Standard Fawn interior with all solid and two-tone exterior colors shown below for Greenbrier De Luxe.

GREENBRIER DE LUXE

INTERIOR	RPO NUMBERS AND EXTERIOR COLORS	
	SOLID	TWO-TONE
Fawn Part of RPO Z60	508—Balboa Blue 507—Brigade Blue 516—Omaha Orange 519—Yuma Yellow 528—Desert Beige 502—Seamist Jade 524—Tangier Gold	538—Balboa Blue & Cameo White 537—Brigade Blue & Cameo White 546—Omaha Orange & Cameo White 549—Yuma Yellow & Cameo White 558—Desert Beige & Cameo White 532—Seamist Jade & Cameo White 554—Tangier Gold & Cameo White
Turquoise Part of RPO Z60	510—Crystal Turquoise 500—Jet Black	540—Crystal Turquoise & Cameo White 530—Jet Black & Cameo White
Red Part of RPO Z60	514—Cardinal Red 521—Pure White 522—Georgian Gray 526—Cameo White	544—Cardinal Red & Cameo White 545—Pure White & Cardinal Red 552—Georgian Gray & Cameo White 541—Cameo White & Cardinal Red
Green Part of RPO Z60	503—Glenwood Green 505—Woodland Green	533—Glenwood Green & Cameo White 535—Woodland Green & Cameo White

SPECIFICATIONS

Wheelbase	95.0
Length (overall)	179.7
Height (loaded)	68.5
Road clearance (min.)	6.6
Tread: Front	58.0
Rear	58.0
Width (overall)	70.0
Interior Room:	Front 2nd Seat
Torso room	39.7 42.7
Leg room	44.5 37.4
Hip room	61.4 61.8
Shoulder room	59.5 59.3
Entrance height	31.5 33.5
Cargo Compartment:	
Center cargo area:	
Double side door opening:	
Width	53.0
Height	51.1
Step height—ground to floor level	16.2
Load floor: Length	52.9
Width	61.2
Maximum height—floor to roof	53.8
Rear cargo floor:	
Double rear door opening:	
Width	46.0
Height	35.4
Loading height	28.5
Load floor: Length	44.9
Width	44.5
Maximum height—floor to roof	39.7
Maximum interior load length behind front seat	117.5
Total cargo volume (cu. ft.)	175.5
Total glass area (sq. in.)	4790.0
Windshield area (sq. in.)	1171.0
Rear window area (sq. in.)	409.0
Tire Size	7.00 x 14
Turning Diameter: (feet) Curb-to-curb	39.2
Wall-to-wall	42.6
Steering Ratio: (overall)	23.1
Fuel tank capacity (gallons)	18.5
Weight: (lbs.)	Greenbrier Greenbrier De Luxe
Curb	3120 3196
Shipping	3005 3081

POWER TEAMS	pages 30-33
BODY FEATURES	pages 40-41
CHASSIS SPECIFICATIONS	pages 42-43
SPECIAL CUSTOM FEATURES	pages 27-29
OPTIONS AND ACCESSORIES	pages 44-45

CORVAIR GREENBRIER DE LUXE SPORTS WAGON

6-DOOR 6-PASSENGER

MODEL R1206 WITH RPO Z60 DE LUXE EQUIPMENT



GREENBRIER DE LUXE SPORTS WAGON FEATURES

(in addition to or replacing standard Greenbrier equipment)

- Bright bumpers and hub caps (optional full wheel covers illustrated)
- Stainless steel windshield reveal molding
- Special red plastic taillight inserts
- Four color-keyed interiors with pattern cloth and textured vinyl seat upholstery
- Color-keyed vinyl sidewall panels with insert and bright molding
- Right and left adjustable sun visors
- White vinyl-coated headlining between roof bows
- Instrument cluster and glove compartment door bright metal facing
- De luxe color-keyed two-toned steering wheel
- Color-keyed front door armrests
- Foam-cushioned seat cushions and backrests
- Cigarette lighter
- Color-keyed vinyl-coated rubber mat floor covering
- Charcoal colored textured vinyl spare tire cover
- Two bright metal second seat ashtrays
- Front and rear dome lights

FOR GREENBRIER DE LUXE SPORTS WAGON COLOR SELECTIONS AND SPECIFICATIONS . . . see page 25

SPECIAL CUSTOM FEATURES FOR GREENBRIER AND GREENBRIER DE LUXE MODELS

OUTDOOR LIVING ACCESSORY EQUIPMENT

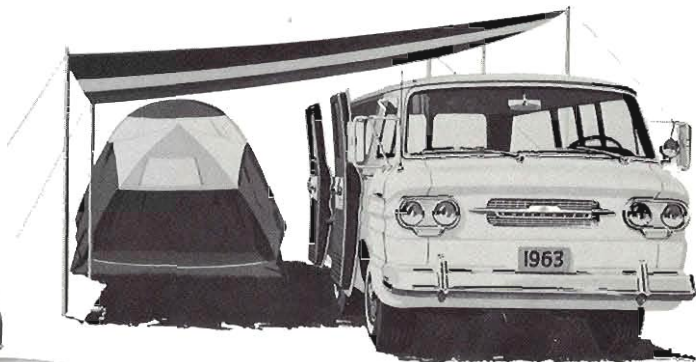

Specially designed Custom Feature Accessories—in addition to regular dealer-installed accessories listed on page 45—for extending Greenbrier versatility to include a wide variety of outdoor business and pleasure uses. Available through authorized Chevrolet dealers.

GREENBRIER SPECIAL CUSTOM FEATURES

CUSTOM CAMPER UNIT (Part No. 985654)—Converts Greenbrier interior into a combination bedroom, living room, and kitchen. Includes: foam-cushioned couch and bed cushions that convert to full-size sleeping area; Formica-topped kitchen unit with stainless steel sink, 11-gallon water tank, built-in ice chest, utility drawer with silverware compartment, roomy storage shelves below sink concealed by double doors with bright chromed hardware, and three convenient end shelves; double sliding door wardrobe storage compartment with individual mirrors; side wall cabinet with two storage compartments; drop-leaf table; vinyl floor covering with bright molding; eight sets of drapes; plus convenient built-in storage drawers and compartments.

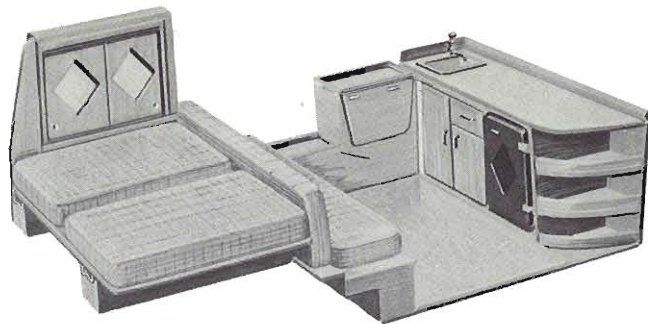

CARGO NET (Part No. 985104)—Extra-strong vinyl cargo net attaches to roof and floor, permitting full-height luggage stacking. Complete with five heavy-duty adjustable straps.

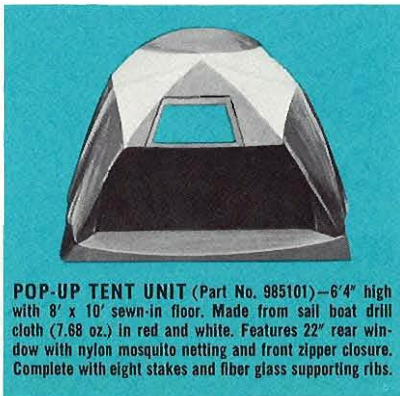

POP-UP TENT UNIT (Part No. 985101)—6'4" high with 8' x 10' sewn-in floor. Made from sail boat drill cloth (7.68 oz.) in red and white. Features 22" rear window with nylon mosquito netting and front zipper closure. Complete with eight stakes and fiber glass supporting ribs.



SHELTER UNIT (Part No. 985106)—13' long, 10' wide at front, 7½' wide at rear. Complete with four aluminum poles, ropes, stakes, and rope tighteners. Made from 10oz. Army Duck in red and white colors to match tent unit.

LUGGAGE CARRIER (Part No. 988398)—Securely attaches to roof—adds extra luggage capacity.



DRAWER UNIT (Part No. 985105)—15" deep, 35" wide, 7" high. Installs under second seat.

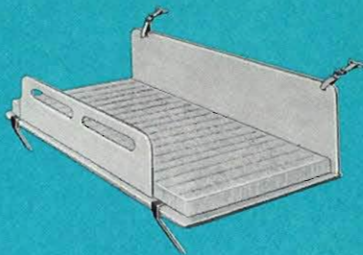

CHILD BED (Part No. 985359)—Fold-down child's bed converts front seat to added sleeping room.



SCREENS, SIDE WINDOWS (Part No. 985100)—Set of four for side window ventilation.

SLEEPER UNIT (Part No. 985102)—Car top sleeper unit 6½' long, 4' wide, and 33" high. Accommodates ¾ size double bed mattress or two 27" x 72" air mattresses. Complete with supports, safety straps, fittings, hardware, and 2-piece ladder.

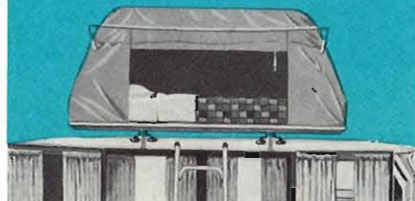

CUSTOM TABLE (Part No. 985107)—Large 2' x 4' removable table for either inside or outside use.

1963 CORVAIR POWER TEAMS / ENGINES, TRANSMISSIONS, AXLE RATIOS

ENGINE		3-SPEED SYNCHRO-MESH (STANDARD)	4-SPEED SYNCHRO-MESH (RPO M20)	POWERGLIDE (RPO M35)
STANDARD ENGINE—ALL CORVAIR AND GREENBRIER MODELS	80-HP TURBO-AIR 145* (145-CU.-IN. 6)	900, 700, 500 SERIES: STD.—3.27:1 GENERAL PURPOSE AXLE OPT.—3.55:1 SPECIAL PURPOSE OR MOUNTAIN AND 3.89:1 HIGH PERFORMANCE AXLES	900, 700, 500 SERIES: STD.—3.27:1 GENERAL PURPOSE AXLE OPT.—3.55:1 SPECIAL PURPOSE OR MOUNTAIN AND 3.89:1 HIGH PERFORMANCE AXLES	900, 700, 500 SERIES: STD.—3.27:1 GENERAL PURPOSE AXLE OPT.—3.55:1 SPECIAL PURPOSE OR MOUNTAIN AND 3.89:1 HIGH PERFORMANCE AXLES
		GREENBRIER SERIES: 3.89:1 GENERAL PURPOSE AXLE ONLY	GREENBRIER SERIES: 3.89:1 GENERAL PURPOSE AXLE ONLY	GREENBRIER SERIES: 3.89:1 GENERAL PURPOSE AXLE ONLY
RPO L62 HIGH PERFORMANCE ENGINE—OPTIONAL FOR CORVAIR 900, 700, AND 500 SERIES MODELS ONLY	102-HP TURBO-AIR 145 (145-CU.-IN. 6)	STD.—3.27:1 GENERAL PURPOSE AXLE OPT.—3.55:1 SPECIAL PURPOSE OR MOUNTAIN AND 3.89:1 HIGH PERFORMANCE AXLES	STD.—3.08:1 GENERAL PURPOSE AXLE OPT.—3.27:1, PERFORMANCE CRUISE 3.55:1 SPECIAL PURPOSE OR MOUNTAIN AND 3.89:1 HIGH PERFORMANCE AXLES	STD.—3.27:1 GENERAL PURPOSE AXLE OPT.—3.55:1 SPECIAL PURPOSE OR MOUNTAIN AND 3.89:1 HIGH PERFORMANCE AXLES
RPO L87 TURBO-SUPERCHARGED ENGINE FOR MONZA SPYDER CLUB COUPE AND CONVERTIBLE MODELS ONLY	150-HP TURBOCHARGED 145 (145-CU.-IN. 6)	3.55:1 HIGH PERFORMANCE AXLE ONLY	3.55:1 HIGH PERFORMANCE AXLE ONLY	

*Powerglide equipped Monza models only; 84 hp, 9.0:1 compression ratio. Note: Optional Positraction rear axle available with standard and optional axle ratios.

TRANSMISSION AND CLUTCH SPECIFICATIONS

3-SPEED SYNCHRO-MESH

Standard with all engines. Manually operated 3-speed transmission with synchronized second and third gear. Floor-mounted gearshift lever.

Ratios

First	3.50:1
Second	1.99:1
Third	1.00:1
Reverse	3.97:1

4-SPEED SYNCHRO-MESH—RPO M20

Manually operated 4-speed transmission with full synchronization of all forward gears. Floor-mounted gearshift lever.

Ratios

First	3.65:1
Second	2.35:1
Third	1.44:1
Fourth	1.00:1
Reverse	3.66:1

POWERGLIDE—RPO M35

2-speed three-element torque converter automatic transmission similar in principle to conventional Chevrolet and Chevy II Powerglide transmissions, but specifically engineered for transaxle drive. Instrument panel mounted indicator and gearshift selector lever. Selector sequence:

L-D-N-R. Accelerator-actuated automatic downshift into low gear for extra passing power.

Torque Multiplication

Drive (maximum)	4.73:1 to 1:1 range
Low and reverse	4.73:1 to 1.82:1 range

CLUTCHES . . . for Corvair 3- and 4-Speed Transmission Power Teams

	80-hp Turbo-Alr 145	102-hp Turbo-Alr 145	150-hp Turbocharged 145
Type	Diaphragm spring with single dry disc	Diaphragm spring with single dry disc	Diaphragm spring with single dry disc
Spring Effective Plate Load—lbs.	900-1075	900-1075	1250-1450
Disc Facing Material	Woven asbestos	Woven asbestos	Woven asbestos
Disc Facing Outside Diameter (Inches)	8.0	8.0	8.0
Disc Facing Total Area (sq. in.)	44.0	44.0	44.0

80-, 102-HP TURBO-AIR 145

	(Standard) 80-HP TURBO-AIR 145	(RPO L62) 102-HP TURBO-AIR 145
ENGINE TYPE	AIR-COOLED HORIZONTALLY OPPOSED 6-CYLINDER—VALVE-IN-HEAD	
DISPLACEMENT	145 CU. IN.	
BORE & STROKE	3.4375" x 2.60"	
HP @ RPM	80 @ 4400*	102 @ 4400
TORQUE @ RPM (ft. lbs.)	128 @ 2300*	134 @ 2800-3000
COMPRESSION RATIO	8.0:1*	9.0:1
CARBURETION	TWIN SINGLE-BARREL WITH AUTOMATIC CHOKE	
FUEL REQUIREMENT	REGULAR*	PREMIUM
CAMSHAFT TYPE	ECONOMY-CONTOURED	SPECIAL PERFORMANCE
VALVE LIFTERS	HYDRAULIC	
EXHAUST SYSTEM	SINGLE	

*In Monza models equipped with Powerglide: Compression ratio—9.0:1, HP—84 @ 4400, Torque—130 @ 2300, Recommended fuel—premium.

102-hp Turbo-Air 145 Deck Lid Emblem

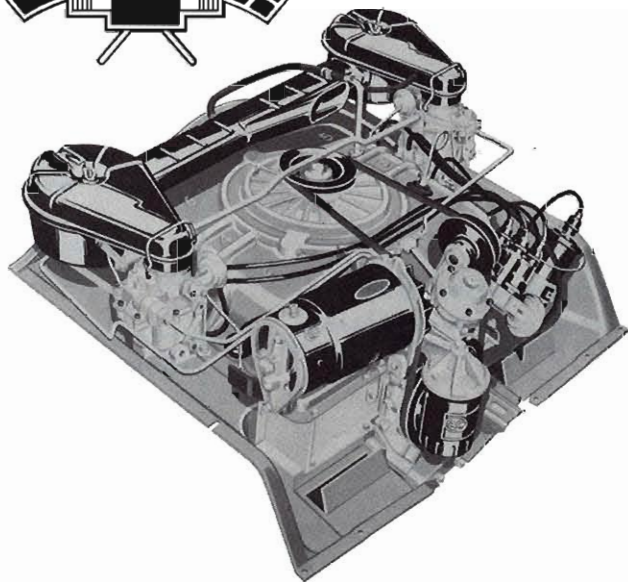

BASIC DESIGN. Valve-in-head horizontally opposed six, 3.4375" bore x 2.60" stroke, 145-cubic-inch piston displacement. Precision-cast aluminum alloy crankcase and cylinder heads, cast alloy iron individual cylinders. Precision-cast wedge-type combustion chambers. Three-ring aluminum alloy pistons with offset piston pins and special steel struts to control expansion. Wear-resistant coated top and second ring, three-piece oil control ring (two rails and one spacer-expander) with chromed rails. Forged steel connecting rods with piston pins clamped in upper end and replaceable lower bearings. Rugged forged steel crankshaft with four replaceable main bearings. High-quality steel-backed babbitt main and connecting rod bearing inserts (special quality sintered bronze in Greenbrier and 102-hp Turbo-Air engines). Flywheel: machined cast alloy iron with manual transmissions, pressed steel with Powerglide. Power plant mounted on rubber cushions, two front, one rear.

FUEL AND INDUCTION SYSTEM. Twin single-barrel carburetors with automatic choke and oil-wetted polyurethane element air cleaners. Intake manifolds cast integral with aluminum cylinder heads. Mechanical pulsator-type fuel pump driven by crankshaft. Sintered fuel filter in each carbu-

retor, fine-mesh fuel strainer in fuel tank. Electric fuel gauge. Fuel tank capacity 14 gallons (18.5 gallons on Greenbrier). Recommended fuel: regular with 80-hp, premium with 84- and 102-hp engines.

VALVE SYSTEM. Valve-in-head, with independent operating mechanism for each valve. Pressed steel rocker covers. Valve material: intake, carbon steel with aluminized face; exhaust, high alloy steel. Separate valve guides and valve seat inserts in cylinder heads. Variable-pitch valve springs. Pressed steel rocker arms with ball and socket mounting. Tubular steel push rods actuated by quiet hydraulic valve lifters. Cast alloy iron camshaft, with wear-resistant coating, mounted on four aluminum crankcase bearing surfaces and driven from crankshaft by quiet gears.

EXHAUST SYSTEM. Single, with cylindrical reverse-flow muffler. Cast iron exhaust manifolds fitted to three steel sleeves pressed into exhaust ports of cylinder head. Rolled lock seam muffler construction. Aluminized heads and asbestos-wrapped extra-thick body with aluminized cover. Tailpipe aluminized. Exhaust pipe diameter: main pipe—1.875", branches—1.375". Tailpipe diameter—1.75".

ELECTRICAL SYSTEM. 12-volt, with 42-ampere-hour battery and 30-ampere generator standard equipment (optional heavy-duty generator listed on page 44), protected by voltage and current regulator. Positive-shift starter with solenoid-engaged drive pinion and overrunning clutch. Hermetically sealed ignition coil. Single-breaker distributor with combination centrifugal and vacuum spark advance. Non-metallic high-tension spark cables. Spark plugs: AC 46 FF with 80-hp engine, AC 44 FF with 84- and 102-hp engines. Rubber boots.

COOLING SYSTEM. Forced-air type with thermostatically controlled air flow over fins formed on cylinder barrels and heads. Engine enclosed by sheet metal shrouds to direct air over engine components. Cooling controlled by thermostatically regulated air exhaust doors at rear of each lower shroud.

LUBRICATION SYSTEM. Controlled full-pressure type with oil cooler and full-flow canister-type oil filter. Refill capacity 4 quarts (4.5 with filter replacement). Gear type oil pump, with fixed intake, develops normal 40 p.s.i. oil pressure at 2000 engine rpm. Red oil pressure warning light on instrument panel. Positive-type crankcase ventilation standard.

150-HP TURBOCHARGED 145 (PART OF MONZA SPYDER OPTION—RPO L87)

ENGINE TYPE	AIR-COOLED HORIZONTALLY OPOSED 6-CYLINDER—VALVE-IN-HEAD
DISPLACEMENT	145 CU. IN.
BORE & STROKE	3.4375" x 2.60"
HP @ RPM	150 @ 4400
TORQUE @ RPM (ft. lbs.)	210 @ 3200-3400
COMPRESSION RATIO	8.0:1
CARBURETION	SINGLE SIDE-DRAFT AUTOMATIC CHOKE TURBO-SUPERCHARGER
FUEL REQUIREMENT	PREMIUM
CAMSHAFT TYPE	SPECIAL PERFORMANCE
VALVE LIFTERS	HYDRAULIC
EXHAUST SYSTEM	SINGLE

Turbocharged 145 Deck Lid Emblem

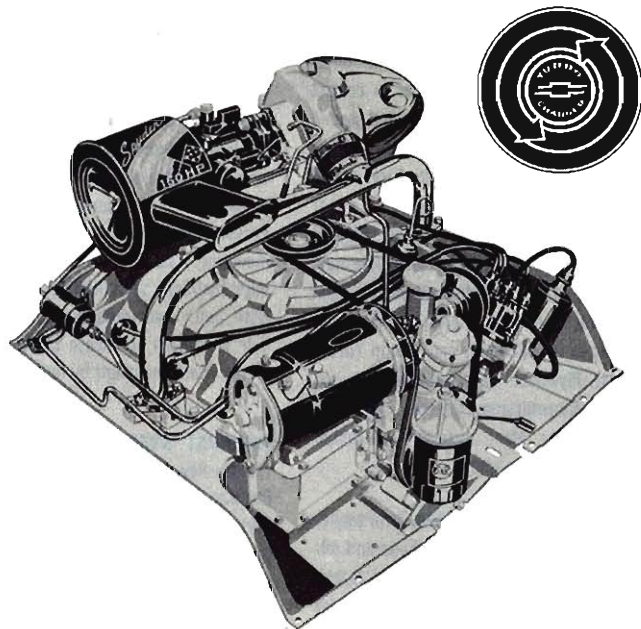

BASIC DESIGN. Valve-in-head horizontally opposed six, 3.4375" bore x 2.60" stroke, 145-cubic-inch piston displacement. Precision-cast aluminum alloy crankcase and cylinder heads, cast alloy iron individual cylinders. Precision-cast wedge-type combustion chambers. Compression ratio: 8.0:1. Heavy-duty three-ring aluminum alloy pistons with offset piston pins and special steel struts to control expansion. Chrome plated upper ring, wear-resistant coated second ring, and three-piece oil control ring (two rails and one spacer-expander) with chromed rails. Heavy-duty forged steel connecting rods with piston pins clamped in upper end and replaceable lower bearings. Heavy-duty forged alloy steel crankshaft with four replaceable main bearings. Premium quality aluminum main and connecting rod bearing inserts. Machined cast alloy iron flywheel. Power plant mounted on rubber cushions, two front, one rear.

FUEL AND INDUCTION SYSTEM. One single-barrel 3-venturi side-draft carburetor with automatic choke and oil-wetted polyurethane-element air cleaner. Exhaust gas driven turbo-supercharger turbine drives special 14-blade precision-cast aluminum centrifugal impeller located between carburetor and fuel induction crossover tube forcing fuel-air mixture through induction

tube to each cylinder bank. (See also Turbo-supercharger, Exhaust Driven . . . Feature Details Section) Intake manifolds cast integral with aluminum cylinder heads. Mechanical pulsator-type fuel pump driven by crankshaft. Replaceable paper element fuel filter between fuel pump and carburetor with special vapor-lock preventing pressure relief by-pass line from fuel filter to tank. Fine-mesh strainer in fuel tank. Electric fuel gauge. Fuel tank capacity 14 gallons. Recommended fuel: premium or special premium.

VALVE SYSTEM. Valve-in-head, with independent operating mechanism for each valve. Pressed steel rocker covers. Valve material: intake, carbon steel with aluminized face; exhaust, special 2-piece welded super-alloy exhaust valves with silicon and chromium steel alloy stems. Special valve guides and valve seat inserts. Variable-pitch valve springs. Pressed steel rocker arms with ball and socket mounting. Tubular steel push rods actuated by quiet hydraulic valve lifters. Cast alloy iron camshaft, with wear-resistant coating, mounted on four aluminum crankcase bearing surfaces and driven from crankshaft by quiet gears.

EXHAUST SYSTEM. Single, with oval reverse-flow muffler. Cast iron exhaust manifolds fitted to three steel sleeves pressed into exhaust ports of cylinder head. Rolled lock seam muffler construction, completely aluminized inside and out.

Chrome-plated tailpipe. Exhaust pipe diameter: main pipe—1.875" increasing to 2.50"; branches—1.375". Tailpipe diameter—2.50".

ELECTRICAL SYSTEM. 12-volt, with 42-ampere-hour battery and 30-ampere generator standard equipment (optional heavy-duty generator listed on page 44), protected by voltage and current regulator. Positive-shift starter with solenoid-engaged drive pinion and overrunning clutch. Hermetically sealed high capacity ignition coil. Single-breaker distributor with combination centrifugal advance and pressure retard spark control. Non-metallic high-tension spark cables. Spark plugs: AC 44 FF with rubber boots.

COOLING SYSTEM. Forced air type with thermostatically controlled air flow over fins formed on cylinder barrels and heads. Engine enclosed by sheet metal shrouds to direct air over engine components. Cooling controlled by thermostatically regulated air exhaust doors at rear of each lower shroud.

LUBRICATION SYSTEM. Controlled full-pressure type with oil cooler and full-flow canister-type oil filter. Refill capacity 4 quarts (4.5 with filter replacement). Gear type oil pump, with fixed intake, develops normal 40 p.s.i. oil pressure at 2000 engine rpm. Red oil pressure warning light on instrument panel. Positive-type crankcase ventilation standard.

CORVAIR BODY FEATURES

900, 700, 500 SERIES

MONOSTRUT BODY BY FISHER

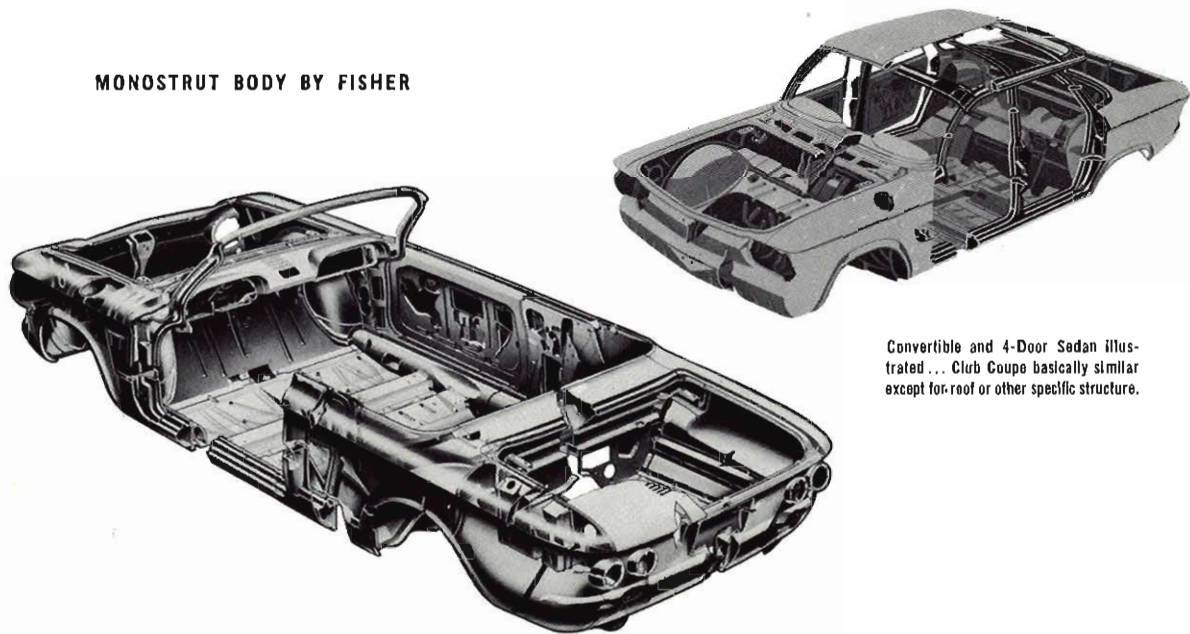

Convertible and 4-Door Sedan illustrated... Club Coupe basically similar except for roof or other specific structure.

BODY STRUCTURE

Fully unitized, all-welded heavy-gauge steel body construction with:

- Rugged box-section design roof rails, windshield and rear window headers, door and roof pillars.
- Heavy-gauge steel roof panel with single flanged-channel lateral reinforcement.
- High-strength double-walled cowl unit-welded to instrument panel, front body panel, and dash panel.
- Deeply ribbed and contoured floor panel with massive underbody-reinforcing box-section crossmembers.
- Extra-rugged heavy-gauge steel double box-section body sills and extensions.
- Integrated extra-rigid front and rear body structures.
- Double-panel door, front luggage compartment lid and rear deck lid construction.
- Special extra-strength reinforcing structure on Convertible.
- Fully counterbalanced luggage compartment lid.
- Structural components and body panels protected from corrosion by various primer coatings, zinc coatings, and anti-rust compounds. Selected structural members heavily zinc coated before assembly.
- All exposed undersurfaces further protected with corrosion-resisting paint.

SOUND INSULATION

- Asphalt-impregnated felt blanket roof, engine compartment lid, and luggage compartment lid insulation.
- Interiors insulated from engine compartment by inch-thick fiberglass blanket on engine side of rear bulkhead, and by thick jute blanket, fiberboard and fibrous mat blanket on passenger side.
- Asphalt-impregnated felt blanket floor insulation under seats, plus heavy jute mat underneath floor covering.
- Spray-on sound deadening compound on inner surfaces of door outer panels and sidewall panels.
- Asphalt-impregnated fiber undercoating on underbody and wheelhousings.

WEATHERSEALING

- Vinyl-covered rubber windlace around door openings.
- Weather tight formed rubber windshield and rear window seals.
- Rubber-fabric glass channel and window sill seals.
- Double-sealing formed rubber door seals.
- Formed rubber luggage compartment lid seal.
- Special body seam and joint sealing compounds.

PLUS...ALL THESE QUALITY FEATURES

- High-Level ventilation system
- Built-in forced-air heater and defroster system
- Parallel-action electric windshield wipers
- Magic-Mirror acrylic lacquer finish
- Single-key lock system
- Lined stowage compartment behind rear seat on all Sedan models
- Locking front luggage compartment
- Friction-type ventipanes
- Triple-safe door locks
- Push-button type outside door handles
- Weather-shielded key locks
- Color-keyed interior trim
- Extra-quality interior features and appointments
- Full-view instrument panel with complete complement of instruments and controls, cigarette lighter, and locking glove compartment

CORVAIR CHASSIS SPECIFICATIONS

900, 700, 500 SERIES

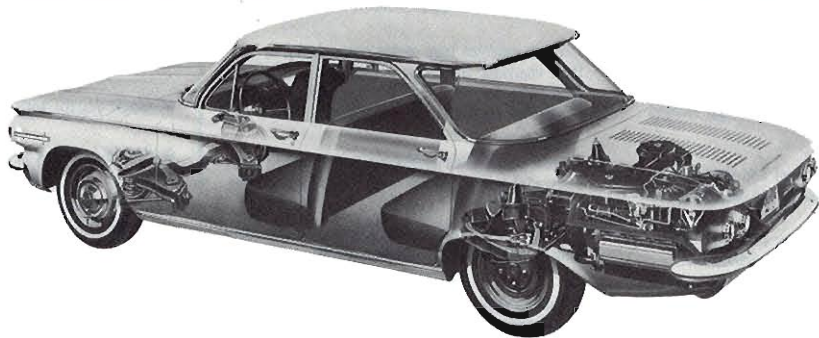

Corvaire Quadri-Flex 4-wheel Independent suspension and transaxle-drive rear-mounted Unipack Power Team.

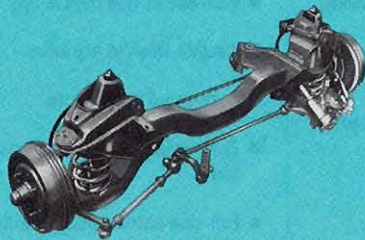

Independent coil spring spherical joint front suspension.

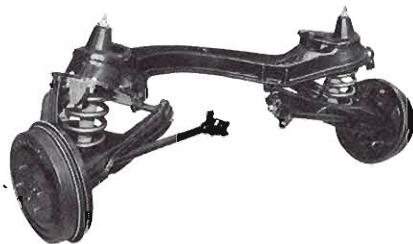

Corvaire swing-axis Independent rear suspension.

QUADRI-FLEX 4-WHEEL INDEPENDENT SUSPENSION

Front: Coil spring spherical joint independent suspension with long and short control arms. Concentric springs and shock absorbers diagonally located between lower control arms and front crossmember. Quiet non-metallic spherical joint liners. Built-in anti-dive control helps keep car level during severe stops. **Rear:** Swing-axle rear suspension with universal joint attachment to axle permits independent movement of each rear wheel. Concentric coil springs and shock absorbers mounted between upper crossmember and lower control arms. Lower control arm attached to crossmember at rubber-bushed pivot points. Crossmember bolted to body and insulated by heavy rubber cushions prevents transference of road sounds and vibration.

SHOCK ABSORBERS

Direct, double-acting, permanently sealed hydraulic shock absorbers specifically engineered to complement suspension systems for improved ride control. Both front and rear shock absorbers concentrically located within coil springs.

TRANSAXLE DRIVE

Transmission and rear axle combined into one compact unit . . . combines with engine to form rear-mounted Unipack Power Team. Hypoid-type axle connected to axle shafts by universal joints. Flow of torque from engine and transmission to axle accomplished by unique 2-unit drive shaft design. 3- and 4-speed transmissions and axle share a common lubrication system. Capacities are: 3-speed—2.2 pints, 4-speed—3.6 pints, rear axle—4 pints. Powerglide transmissions have separate lubrication system apart from rear axle with 6 pints refill capacity (13 pints total).

STEERING

Balanced, symmetrical system with relay-type linkage and high-ratio Ball-Race steering gear. Overall steering ratio—23.5:1. Steering wheel diameter—16". Wheel turns stop to stop—4.60.

SAFETY-MASTER BRAKES

Self-adjusting air-cooled Safety-Master 4-wheel hydraulic brake system basically similar to that of conventional Chevrolet. Brake drum diameter—9". Lining width—front and rear: 1.75". Total effective lining area—126.14 sq. in. Braking dis-

tribution—front: 46%, rear: 54%. Full molded asbestos composition linings bonded to brake shoes. Composite steel and cast iron brake drums with wide cooling flanges for rapid heat dissipation. Parking brake operation by pistol-grip control lever to left of steering column. Optional* sintered-metallic brake linings available for unusually severe, heavy-duty operation.

MUFFLER

Long-life reverse-flow type muffler constructed of highly corrosion-resistant materials discharges exhaust gases with minimum sound and power-robbing back pressure. For specific details see pages 33-35, Corvair section or Feature Details section.

WHEELS AND TIRES

Welded steel short-spoke disc 13" diameter, 5.5" rim width wheels with special cooling slots for circulating air around brakes. Black sidewall highway rayon 4-ply rating tires standard. White sidewall tires optional* on all models. All wheels and tires statically balanced for smooth, quiet operation and longer tire life. For tire sizes see model specifications.

*Optional at extra cost

SPECIAL CHASSIS EQUIPMENT—For complete list of special options see page 44, Corvair section

GREENBRIER BODY FEATURES



Greenbrier utilized van-type body.

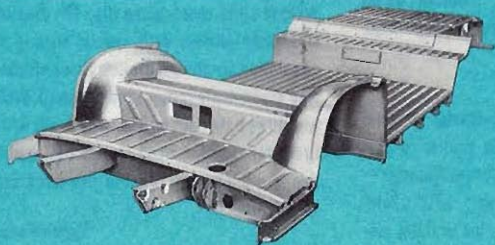

Heavily ribbed and contoured Greenbrier floor panel assembly.



Versatile 2-position double-side and double-rear door checks allow doors to be fully opened for convenient close-up loading.

BODY STRUCTURE

Fully unitized heavy-gauge steel van-type body construction. Basic body structure comprised of five all-steel substructures solidly welded to form an integrated unit of exceptional strength and rigidity with extra-large load capacity. Heavy-duty design features include:

- Heavily ribbed and contoured floor panel assembly reinforced with massive crossmembers and lateral reinforcing sill structures. Unique drop-center floor increases cargo capacity, contributes to easier loading.
- Full-length combination box- and hat-section underbody-reinforcing sills. Box-section front sill integrated with intermediate and rear sills through heavy-duty shear plates and lateral supports.
- High-strength double-walled front end structure unit-welded to instrument panel, floor, box-section windshield header, and full height box-section windshield and door hinge pillars.
- Extra-heavy gauge steel roof panel with welded-on full-perimeter rails, and reinforced with seven flanged-channel lateral supports.
- Front door lock pillars, right-side double-side door hinge pillars, side window pillars, and body side panels solidly welded to form rigid, high-strength side structures integrating floor and roof.
- Body side and door outer panel styling features sculptured, full-length concave grooves for distinctive appearance and greater rigidity.

- Integrated, extra-rigid rear body structure with box-section rear door opening and roof support pillars joins sides, roof, and floor structures.

- Double-panel construction front, double-side, and double-rear doors.

- Corrosion-resisting high zinc content chromate primer applied to entire lower underbody. Wheelhouse areas protected with spray-on undercoating.

SOUND INSULATION

- Engine access door in rear cargo floor insulated with special fiber glass blanket.

- Special spray-on sound deadening compound on inner surfaces of door outer panels and sidewall panels.

- Asphalt-impregnated felt blanket floor insulation under front seat, plus jute mat underneath floor covering.

- Spray-on asphalt-impregnated fiber sound deadening on underbody and wheel housings.

WEATHERSEALING

- Vinyl-covered windlace around door openings.

- Weather-tight formed rubber windshield, stationary side window, and double-rear door window seals.

- Rubber-fabric front door and double-side door glass channel and window sill seals.

- Special body seam and joint sealing compound.

PLUS . . . ALL THESE QUALITY FEATURES

- High-Level ventilation system

- Parallel-action electric windshield wipers

- Extra-large full-view windshield

- High quality synthetic enamel finish

- Single-key lock system

- Friction-type ventipanes

- Wide-opening front, double-right side and double-rear doors

- Pushbutton-type outside door handles

- Left side double doors optional at extra cost

- 2-position double-side and double-rear door checks

- Low side door step height for extra-easy loading or entrance

- Versatile 3-position, removable second seat

- Adjustable front seat with adjustable backrest

- Front, side, and rear door weather-shielded key locks

- Roll-down front door and side windows

- Quality interior features and appointments

- Full-view instrument panel with complete complement of instruments and controls and locking glove compartment

GREENBRIER CHASSIS SPECIFICATIONS

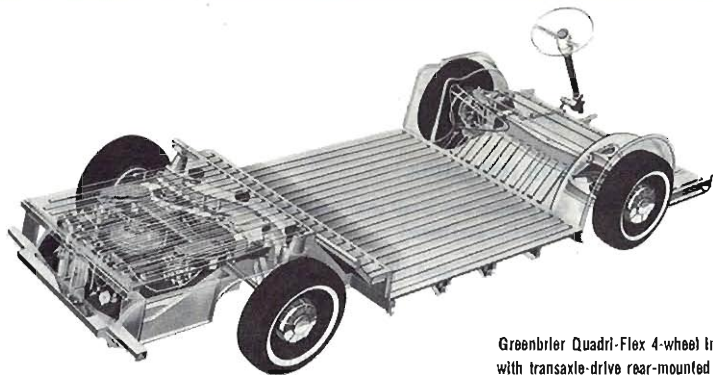

Greenbrier Quadri-Flex 4-wheel Independent suspension with transaxle-drive rear-mounted Unipack Power Team.

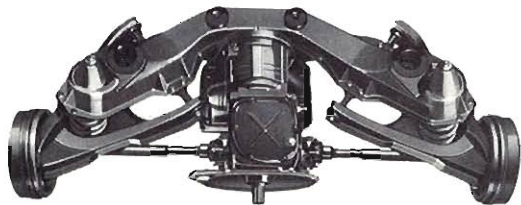

Greenbrier swing-axle Independent rear suspension.



Independent coil spring spherical joint front suspension.

QUADRI-FLEX 4-WHEEL INDEPENDENT SUSPENSION

Front: Coil spring spherical joint independent suspension with long and short control arms. Concentric springs and shock absorbers diagonally located between lower control arms and front crossmember. Quiet non-metallic spherical joint liners. Built-in leveling control helps keep car level during severe stops. **Rear:** Swing-axle rear suspension with universal joint attachment to axle permits independent movement of each rear wheel. Concentric coil springs and shock absorbers mounted between upper crossmember and lower control arms. Lower control arm attached to crossmember at rubber-bushed pivot points. Crossmember bolted to body-frame structure and insulated by heavy rubber cushions prevents transference of road sounds and vibration to body.

SHOCK ABSORBERS

Direct, double-acting, permanently sealed hydraulic shock absorbers specifically engineered to complement suspension systems for improved ride control. Both front and rear shock absorbers concentrically located within coil springs.

TRANSAXLE DRIVE

Transmission and rear axle combined into one compact unit . . . combines with engine to form rear-mounted Unipack Power Team. Hypoid-type axle connected to axle shafts by universal joints. Flow of torque from engine and transmission to axle accomplished by unique 2-unit drive shaft design. 3- and 4-speed transmissions and axle share a common lubrication system. Capacities are 3-speed—2.2 pints, 4-speed—3.6 pints, rear axle—4 pints. Powerglide transmissions have separate lubrication system apart from rear axle with 6 pints refill capacity (13 pints total).

STEERING

Balanced system with relay-type linkage and low-friction Ball-Race steering gear. Overall steering ratio—23.0:1. Steering wheel diameter—17".

SAFETY-MASTER BRAKES

Self-adjusting air-cooled Safety-Master 4-wheel hydraulic brake system basically similar to regular Corvaire. Brake drum diameter—11". Lining width—front and rear: 2.00". Total effective lining area—153.9 sq. in. Braking distribution—front: 56%,

rear: 44%. Full molded asbestos composition linings bonded to brake shoes. Composite steel and cast iron brake drums with wide cooling flanges for rapid heat dissipation. Parking brake operation by pistol-grip control lever to left of steering column.

MUFFLER

Long-life reverse-flow type muffler constructed of highly corrosion-resistant materials discharges exhaust gases with minimum sound and power-robbing back pressure. For specific details see page 33, Corvaire section, or Feature Details section.

WHEELS AND TIRES

Welded steel short-spoke disc 14" diameter, 5.0" rim width wheels with special cooling slots for circulating air around brakes. Black sidewall highway rayon 4-ply rating tires standard . . . white sidewall tires optional*. All wheels and tires statically balanced for smooth, quiet operation and longer tire life. For tire size see model specifications.

*Optional at extra cost

CORVAIR FACTORY-INSTALLED OPTIONS AND ACCESSORIES for all models except as otherwise indicated.

ENGINES

RPO L62 102-HP TURBO-AIR 145—All models except Greenbrier. 145 cu. in., 9.0:1 compression ratio. Includes special camshaft and valve springs, and recalibrated carburetors.

TRANSMISSIONS

RPO M35 CORVAIR POWERGLIDE
RPO M20 4-SPEED SYNCHRO-MESH

AXLE RATIOS

RPO G93 3.27:1 PERFORMANCE CRUISE AXLE—For all models with 102-hp Turbo-Air 145 engine and 4-Speed Synchro-Mesh transmission.

RPO G95 3.55:1 SPECIAL PURPOSE OR MOUNTAIN AXLE—For Sedan, Coupe, and Convertible models. Required with Spyder equipment option.

RPO G90 3.89:1 HIGH PERFORMANCE AXLE—For Sedan, Coupe, and Convertible models with 80-hp or 102-hp Turbo-Air 145 engines. Standard axle for Greenbrier.

CORVAIRS OTHER THAN GREENBRIER

RPO C84 AIR CONDITIONER, DE LUXE—All models except Monza Club Coupe and Convertible with Spyder equipment option. Radio required additional equipment.

RPO C48 HEATER AND DEFROSTER DELETION—Credit option omitting standard unit.

RPO U60 MANUAL RADIO AND ANTENNA

RPO U63 PUSHBUTTON RADIO AND ANTENNA

RPO Z02 PUSHBUTTON RADIO, REAR SPEAKER, AND ANTENNA—Sedan and Club Coupe only.

RPO A01 SOFT-RAY TINTED GLASS—All windows.

RPO A02 SOFT-RAY TINTED GLASS—Windshield only.

RPO A67 FOLD-DOWN REAR SEAT—700 and 500 models only. Standard in all Monzas except Convertible.

RPO L87 SPYDER EQUIPMENT OPTION—For Monza Club Coupe and Convertible with 3- or 4-Speed Synchro-

Mesh. Includes 150-hp Turbo-charged 145 engine, special instrumentation, and special Spyder identification emblems. RPO G95 3.55:1 axle required additional equipment.

RPO C06 POWER-OPERATED TOP—Monza Convertible.

RPO Z01 COMFORT AND CONVENIENCE EQUIPMENT—For Monza models includes outside rearview mirror, inside non-glare rearview mirror and 2-speed electric windshield wiper and pushbutton washer. For all other models includes above equipment plus back-up lights and glove compartment light.

RPO D10 REAR DOOR ARMRESTS—For Corvaire 700 4-Door Sedan.

RPO B70 INSTRUMENT PANEL PAD

RPO P01 WHEEL COVERS—Set of four—Standard on Monza.

RPO P02—WHEEL COVERS, SIMULATED WIRE—Set of four.

RPO P45 WHEELS, SPECIAL WIRE—Set of five authentic wire wheels with dual-lug knock-off hubs. Includes 6.50 x 13 blackwall tires and tubes, tube protectors, four adapters, four knock-off hubs, and special knock-off hammer.

RPO P53 THINLINE WHITEWALL TIRES—6.50 x 13 4-p.r. lubeless—All models.

RPO P58 THINLINE WHITEWALL TIRES—6.50 x 13 4-p.r. lube-type—For RPO P45 wire wheels.

RPO P19 SPARE WHEEL AND TIRE LOCK—Not available with air conditioning or wire wheels.

RPO G81 POSITRACTION REAR AXLE—Available with all standard and optional axle ratios.

RPO J65 SINTERED-METALLIC BRAKE LININGS

RPO F40 SPECIAL FRONT AND REAR SUSPENSION—Includes front and rear springs and shock absorbers, front stabilizer bar. Not available with air conditioning.

FOR GREENBRIER

RPO U60 MANUAL RADIO AND ANTENNA

RPO C40 HEATER-DEFROSTER—Forced-air type.

RPO C45 HEATER-DEFROSTER—Aircraft-type gasoline heater.

RPO Z60 GREENBRIER DE LUXE EQUIPMENT—Includes red, green, turquoise, or fawn color-keyed upholstery, vinyl sidewall panels, color-keyed vinyl-coated rubber floor mats; vinyl tire cover; white vinyl-coated headlining between roof bows; two-tone steering wheel; instrument cluster and glove compartment door bright trim panel; cigarette lighter; dual sun visors; front armrests; rear ashtrays; rear dome light; foam-cushioned seats and seat backs; red plastic inserts at taillights; and bright metal hub caps, bumpers, and windshield trim.

RPO A59 REAR (THIRD) SEAT (with RPO Z60 includes rear armrests).

RPO E85 DOUBLE LEFT-HAND SIDE DOORS

RPO A09 LAMINATED GLASS—Front door windows.
RPO V37 CHROME-PLATED HUB CAPS AND FRONT AND REAR BUMPERS—Included in RPO Z60 De Luxe Equipment.

RPO P01 WHEEL COVERS—Set of four.

RPO D32 OUTSIDE REARVIEW MIRROR

RPO R20 WHITEWALL TIRES—7.00 x 14 4-p.r.

RPO R21 BLACKWALL TIRES—7.00 x 14 6-p.r.

RPO R22 WHITEWALL TIRES—7.00 x 14 6-p.r.

RPO R24 BLACKWALL TIRES—7.00 x 14 6-p.r. Extra-capacity (45 p.s.i.) Truck-type.

RPO R25 BLACKWALL TIRES—7.00 x 14 8-p.r. High-capacity (60 p.s.i.) Truck-type.

RPO C14 2-SPEED ELECTRIC WINDSHIELD WIPER—Includes Pushbutton Windshield Washer.

RPO F60 HEAVY-DUTY FRONT SPRINGS AND SHOCK ABSORBERS

RPO G81 POSITRACTION REAR AXLE—3.89:1 ratio.

ALL CORVAIRS INCLUDING GREENBRIER

RPO K71 HEAVY-DUTY GENERATOR—35-ampere, low cut-in.

RPO A37 SEAT BELT—One or two belts.

CORVAIR DEALER-INSTALLED CUSTOM FEATURE ACCESSORIES for all Corvaire and Greenbrier models except as indicated

	PART NO.		PART NO.		PART NO.
Accelerator Pedal Cover.....	985260	Guard—Front or Rear Bumper All Sedan and Coupe Models.....	988203	Rearview Mirror—Inside—Non-Glare.....	985152
Air Conditioner—De Luxe (not available with Greenbrier and Monza Spyder models)		Greenbrier—Painted.....	985070	Rearview Mirror—Outside—Body Mount Sedan, Coupe, and Convertible.....	985434
All except Convertible.....	985146	Greenbrier—Chrome.....	988373	Greenbrier.....	985285
Convertible.....	985392	Hazard Flasher Switch (Greenbrier only)	985600	Seat Belt—Front Aqua—985508, Blue—985499, Red—985498, Green—985510, Fawn—985509, Saddle—985437, Black—985511	
Antenna—Manual—Front All except Greenbrier.....	985450	Heater and Defroster—Forced-Air De Luxe Greenbrier only—Standard on all other Models	985504	Seat Belt—Rear (Except Greenbrier) Aqua—985619, Blue—985622, Red—985620, Green—985621, Fawn—985618, Saddle—985623, Black—985541	
Greenbrier.....	985444	Heater and Defroster—Gasoline type Greenbrier only.....	985648	Speaker—Radio Rear Auxiliary All Except Greenbrier and Convertible.....	985590
Cigarette Lighter (Greenbrier only).....	985609	Hook—Coat (Except Convertible).....	985350	Tissue Dispenser.....	985483
Clock—Electric.....	985329	Lamp—Dome (Greenbrier only).....	988346	Tool Kit.....	988032
Compass—Illuminated.....	985002	Lamp—Glove Compartment (700, 500, and Greenbrier).....	985273	Ventshade 2-Door Models.....	985167
Cover—Rear Seat Compartment.....	988363	Lamp—Luggage Compartment (Except Green- brier).....	985425	4-Door Models.....	985166
Cushion Toppers—Except Greenbrier Front: all models—985568 Rear: all 2-door except Convertible—985570, Convertible—985571, 4-Door—985569		Lamp—Safetylight (Greenbrier only).....	988335	Greenbrier.....	985025
Cushions, Ventilated Brown—985554, Blue—985552, Black—985555, Green—985553, Red—985551		Lamp—Spot—Portable (Connects to Cigarette Lighter).....	987112	Visor—R. H. Sun (Greenbrier).....	985238
Door Edge Guards 2-Door Models.....	988422	Lamp—Underhood (Except Greenbrier).....	985475	Wheel Covers—Full—Set of Four. (Standard on Monza) 700 and 500 Models.....	985424
4-Door Models.....	988082	Lamps—Back-Up, Standard on Monza Models. Not available on Greenbrier.....	985417	Greenbrier.....	985433
Extinguisher—Fire (2¼ lb. dry chemical).....	985592	Lamps—Courtesy (Standard on Convertible).....	985574	Wheel Covers—Wire (Except Greenbrier).....	985373
Extinguisher—Refill Cartridge.....	985593	License Plate Bezel.....	985325	Windshield Washer—Pushbutton All except Greenbrier.....	985512
Floor Mat—De Luxe Full-Width Front (Except Greenbrier) White—985095, Aqua—985245, Saddle—985464, Black—985094, Blue—985243, Red—985099, Fawn—985244		Light—Open Door Warning.....	985591	Greenbrier.....	985513
Floor Mat—Contour Front (Except Greenbrier) White—985018, Aqua—985242, Saddle—985463, Black—988295, Blue—985240, Fawn—985241		Litter Container.....	985482	GREENBRIER SPECIAL CUSTOM FEATURES see illustrations Corvaire section, pages 27-29	
Floor Mat—Contour Rear (Except Greenbrier) White—985022, Aqua—985211, Saddle—985460, Black—988441, Blue—985208, Red—988440, Green—985209, Fawn—985210		Lock—Rear Door Safety (Except Greenbrier).....	985295	Screens—Side Windows—Set of Four.....	985100
Gas Filler Cap—Locking All except Greenbrier.....	988270	Lock—Spare Tire (Not used with Air Conditioning or Wire Wheels).....	985113	Tent Unit, 8' x 10' x 6'6".....	985101
Greenbrier.....	988277	Luggage Carrier—Roof 4-Door Sedans.....	985056	Car Top Sleeper.....	985102
Gas Filler Door Guard (Except Greenbrier).....	988274	Greenbrier.....	988398	Camper Unit.....	985654
		Luggage Carrier Cover 4-Door Sedans.....	985300	Cargo and Baggage Net.....	985104
		Greenbrier.....	985314	Drawer Unit—Underseat.....	985105
		Mirror and Comb—Vanity Visor.....	987919	Shelter Unit.....	985106
		Parking Brake Warning Light.....	985333	Table Unit.....	985107
		Radio and Antenna—Manual Sedan, Coupe, and Convertible.....	985446	Bed—Child.....	985359
		Greenbrier.....	985442		
		Radio and Antenna—Pushbutton (Except Greenbrier).....	985448		