

# Natural Resource Planning Guide *for* The Ossipee Watershed



Prepared by

**Ossipee Watershed Coalition**  
*in partnership with the*  
**Green Mountain Conservation Group**

*Supported by generous grants from*

NH Department of Environmental Services  
*2006 Watershed Assistance & Restoration Grant*

New Hampshire Charitable Foundation  
Little Family Foundation  
Davis Conservation Foundation  
Adelard and Valeda Lea Roy Foundation  
and GMCG members

**Ossipee Watershed Coalition  
Natural Resource Planning Guide  
TABLE OF CONTENTS**

Guide Cover Page . . . . .	i
Acknowledgements . . . . .	ii
Table of Contents . . . . .	iii
 <b><u>CHAPTER - TOPIC</u></b>	
Chapter I Introduction to the Guide . . . . .	<b><u>TAB</u></b> 1
Chapter II OWC Mission Statement . . . . .	2
Chapter III Ossipee Watershed Coalition Six Towns Statistics . . . . .	3
Chapter IV Geological History of the Ossipee Watershed . . . . .	4
Chapter V Shared Natural Resources of the Ossipee Watershed	
Section A.1 Water Resources – Watershed . . . . .	5
Section A.2 Water Resources – Groundwater . . . . .	6
Section A.3 Water Resources – Lakes and Ponds . . . . .	7
Section A.4 Water Resources – Rivers and Streams . . . . .	8
Section B Wetlands . . . . .	9
Section C Contiguous Open Space and Wildlife Habitat . . . . .	10
Section D Biodiversity . . . . .	11
Section E Forests . . . . .	12
Section F Soils . . . . .	13
Section G Agriculture . . . . .	14
Section H Elevations, Ridgelines and Viewsheds . . . . .	15
Section I Air Quality . . . . .	16
Section J Dark Skies . . . . .	17
Section K Sound . . . . .	18
Chapter VI Economy, Tourism and Growth . . . . .	19
Chapter VII Global Impacts to Shared Natural Resources . . . . .	20
Chapter VIII Natural Resource Planning Recommendations . . . . .	21
Chapter IX GIS Mapping . . . . .	22
Appendix A Annual Update and Matrix Scorecard. . . . .	23
Appendix B Review Process for Enact Zoning Ordinances . . . . .	24
Glossary . . . . .	25

# Natural Resource Planning Guide

## *Acknowledgements*

The Green Mountain Conservation Group would like to extend an enormous *Thank You* to the Ossipee Watershed Coalition for their partnership in creating the Natural Resource Planning Guide. We also thank the NH Department of Environmental Services for their financial support for this project through the *2006 Watershed Assistance and Restoration Grant*. Critical financial support was also provided by grants from: New Hampshire Charitable Foundation; Little Family Foundation; Davis Conservation Foundation; Adelard and Valeda Lea Roy Foundation. GMCG would also like to thank the GMCG membership for their continued support.

Without the expert and tireless efforts of the following contributors this project would not have been possible. Their efforts and contributions are highly valued and greatly appreciated. Very special thanks to the following for their specific help on this project:

- Towns of *Effingham, Freedom, Madison, Ossipee, Sandwich, Tamworth* and residents who have been supportive in attending community meetings for this project since 2004.
- *Ossipee Watershed Coalition* Steering Committee, members who have shared their expertise, extensive local knowledge and deep commitment to natural resource planning, collaborating across political boundaries: Jay Buckley, Noreen Downs, Blair Folts, Lee Pollock, Tara Schroeder, John Shipman (Editor), and Theresa Swanick (Chair)
- *OWC Members, Authors, Reviewers:*  
Jay Buckley, Katie Callahan, Blair Folts, Bob Gillette, Sherry Godlewski (*NH DES*), David Little, Jeff Lougee (*The Nature Conservancy*), Dr. Kamalendu Nath, Dr. Robert Newton (*Smith College*), Dr. Talbot Page (*Brown University*), Peter Pohl, Dr. Lee Pollok, Tina Savage, Wendy Schribner (*UNH Cooperative Ext. Service*), Tara Schroeder, John Shipman, Susan Slack, Dan Stepanauskus, Dan Sundquist (*SPNHF*), Theresa Swanick, Dr. Rick Van de Poll (*EMC*).
- Planning Consultant: Steve Whitman (Jeffrey H. Taylor & Assoc.)

Thanks also to all who attended the Ossipee Watershed Coalition community meetings over the past two years and to all the folks in the watershed who are working to make a difference in natural resource conservation!

Blair Folts, Executive Director

Green Mountain Conservation Group

November 2007

***When citing this document, please refer to it as follows:***

Ossipee Watershed Coalition. Natural Resource Planning Guide for the Ossipee Watershed.  
Produced in Partnership with The Green Mountain Conservation Group, Effingham, NH; 2007. 260 p.

# Ossipee Watershed Coalition

## Natural Resource Planning Guide

### Chapter I - Introduction



#### **I. Purpose of this Guide**

The purpose of this Guide is to provide town officials and planners in the Ossipee Watershed with:

- An enduring reference document in which local experts explain in layman's terms the basic science and ecological value of our natural resources,
- An understanding that these resources cross town boundaries and can most effectively be protected by shared stewardship,
- A reference source for sample ordinances that can be used to protect natural resources in a sustainable way while balancing the needs for economic growth and development, and
- Comprehensive planning recommendations that town officials can use to guide the implementation of methods to best safeguard shared natural resources.

In an effort to offer municipal officials and residents guidelines for natural resource protection, the Green Mountain Conservation Group (GMCG) met with representative officials and citizens from each of the six watershed towns of Effingham, Freedom, Madison, Ossipee, Sandwich and Tamworth to establish the Ossipee Watershed Coalition (OWC). GMCG also contracted with professional planner, Steve Whitman of Jeffrey H. Taylor and Associates, to help: conduct a community survey; facilitate community meetings; and provide guidance and expertise on the drafting of the Guide.

This Guide has been designed to help facilitate strategic watershed-wide long-term land use planning based on conserving shared natural resources. It is the OWC's goal to work with stakeholders in the six watershed towns to develop a common vision for sustainable development to guide growth and preserve shared natural resources. The objective is to foster collaborative planning which balances economic needs with ecological concerns and assists towns in maintaining the viability of shared natural resources through complementary actions in neighboring towns.

## II. Necessity for the Guide

The Ossipee Watershed is projected to be one of New Hampshire's most rapidly growing regions in the next 20 years - experiencing one of the greatest spurts of population growth of any region in the state. According to the Office of Energy and Planning statistics, Carroll County will experience nearly a 50 % population growth by the year 2020 (see Figure 1 below).

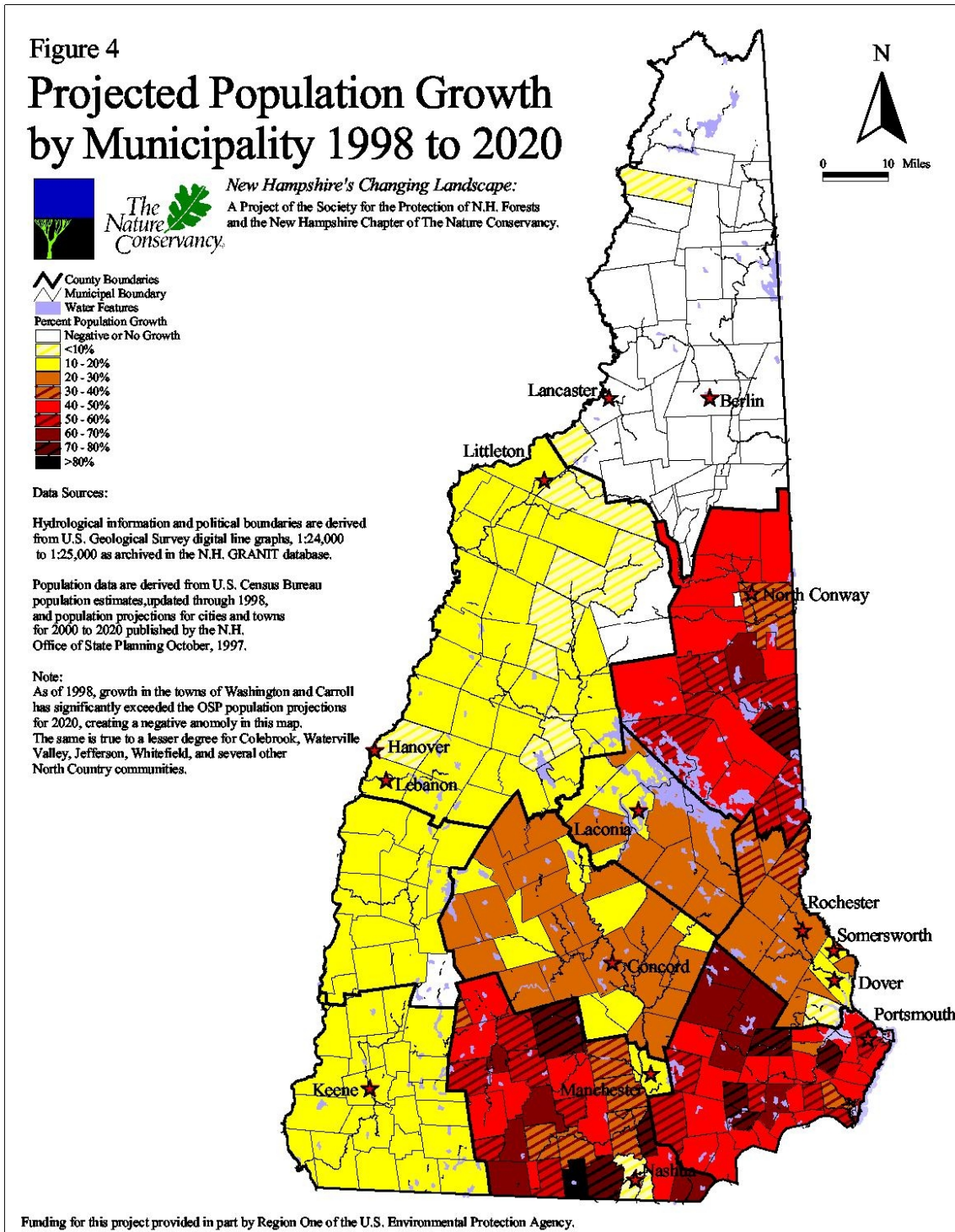

**Chapter II Figure 1** "New Hampshire's Changing Landscape 2005", co-authored by The Society for the Protection of New Hampshire Forests and The Nature Conservancy.

Route 16, the main thoroughfare through the Ossipee region to the White Mountains, runs directly above one of the area’s most sensitive and crucial natural resources: the Ossipee Aquifer, which is New Hampshire’s largest stratified drift aquifer. To date, limited development has occurred in this rural area, but projected increased development, and lack of natural resource based land use planning raises the risk of harmful impacts to our shared natural resources. Increased population, residential and commercial development, and expanded recreational use of the area’s natural resources make it necessary to educate residents, businesses, municipalities and visitors about watershed protection.

**Chapter II Table 1 Growth in Housing**

Town	% Change 1980-2000
Freedom	73.1%
Effingham	43.8%
Ossipee	50.2%
Madison	66.9%
Tamworth	46.3%
Carroll County*	55.5%
Lakes Region	37.1%
New Hampshire	41.6%

In New Hampshire, primary responsibility for land use planning falls to each town, yet few towns have adequate resources to manage the challenge of comprehensively protecting natural resources amid such rapid growth. The OWC has developed this Guide to provide in-depth information about the spectrum of shared natural resources and principles for decreasing risks and supporting their sustainability. The focus is on long-term protection of resources, which requires strategic land use planning in a holistic and preventative manner in the near term.

Included in the Guide are several tools:

- Geographic Information System (GIS) regional maps
- Model ordinances and Best Management Practices (BMPs)
- Discussion of the laws and methods for regulating land use

The Guide is a critical tool for residents and municipal officials to utilize in planning for growth based on natural resource protection. It provides information and resources to assist towns in implementing strategies that minimize, to the greatest extent possible, negative impacts to shared natural resources. By identifying potential threats comprehensively, the six towns will have the information needed to ensure the viability of their important shared natural resources. In order to protect the health of the ecosystems and support the local economy, we must work together to plan for sustainability. In the Ossipee Watershed, most land stewardship efforts have focused on sustaining resources that are here rather than having to restore lost resources. The latter is very difficult and very expensive and in many cases, once a natural resource is lost, it is lost forever.

The importance of sustaining shared resources is a concept that will be explained throughout this Guide. “**Sustainability**” is a concept, relating to the continuity of economic, social, institutional and environmental aspects of society. It is a means of configuring community activity so that people and economies are able to meet their needs and express their greatest potential in the present, while preserving natural ecosystems – planning and acting for the ability to maintain these ideals into the future.

### **III. Background to the Guide**

Efforts to build awareness of natural resources in the Ossipee Watershed, particularly related to its very unique aquifer, and the need for careful land use planning began in 2000, when GMCG undertook a regional GIS mapping project. Over the past 7 years, GMCG has devoted hundreds of hours to educational outreach to town officials and area residents in an effort to spread information about shared natural resources and the need to protect them. As a result, educational efforts have expanded and area residents and municipal officials have come to better understand the link between land use change and water quality. The need for long term water quality monitoring as well as the need for shared community planning initiatives became more evident as each watershed town experienced more rapid growth. A watershed-wide community survey conducted in 2005, showed residents most concerned about how fast the area is growing, how to protect important natural resources such as drinking water, wetlands, wildlife habitat and forests and how to plan for growth in a sustainable way.

Subsequent community discussions made apparent that the different political situations in each watershed town must also be considered. It was recommended that towns adopt similar natural resource chapters within their master plans. If towns in the Watershed share similar natural resources and thus similar natural resource chapters, then the shared resource will be protected across political boundaries. In order to protect our very large shared resource, the Ossipee Aquifer, some community members have suggested future work may include working together to create a shared water protection overlay district for the entire Ossipee Watershed.

An important factor in the Guide development is also to educate municipal officials about how to use this guide book as well as how to use the accompanying GIS maps for natural resource based planning. The Guide is meant to be a working document that is edited and expanded over time.

### **IV. How to Use the Guide**

This planning tool strives to raise awareness of land use activities and their affects on the sustainability of natural resources. It is broken down into chapters and sections by resource category for a comprehensive review of the value of the resource, the potential impacts to it by certain land use activities, and a range of recommendations for its protection, including sample ordinances. A glossary of technical terms is also provided. Protection measures range from community education and Best Management Practices (BMPs) that were selected from a variety of Federal, State, and non-governmental organizations, to land use regulation via town ordinance. One may refer directly to a sample ordinance. However, a review of the technical information is encouraged for two reasons: (1) a basic understanding of the science, offered in layman's terms, is important to make sure the adaptation of an ordinance is tailored to each individual town's needs; and (2) the rationale behind any proposed ordinance must be clearly explained to town voters. It is the Coalition's goal to provide towns with annual updates to this Guide and an evaluation (in matrix form) of the status of ordinances in each town, as they relate to their ability to protect shared natural resources.

#### **Disclaimer**

The model land use regulations, best management practices, and planning policies included in this Guide are intended to provide examples for local communities to consider, but should not be adopted without modification. Land use regulations should be supported by the existing Master Plan, and should fit the context and needs of the community prior to adoption. If this is not taken into consideration, the language will not assist the community in guiding change in a fashion that leads to the community vision. Towns are also encouraged to seek advice from legal counsel before adopting any ordinance or regulation.

# Ossipee Watershed Coalition

## Natural Resource Planning Guide

### Chapter II – OWC Mission Statement

The Ossipee Watershed Coalition (OWC) was established in the fall of 2004, in partnership with the Green Mountain Conservation Group (GMCG) through a NH DES Watershed Assistance and Restoration Grant to focus on natural resource planning in the Ossipee Watershed. GMCG and OWC have worked with municipal officials, residents, and businesses in the six towns of Effingham, Freedom, Madison, Ossipee, Sandwich, and Tamworth in efforts to promote natural resource based planning since 2004.



*OWC Community Meeting March 24, 2006  
Group working with GIS maps to discuss shared natural resources.*

The mission of the OWC, defined through a series of facilitated community meetings is:

***“The Ossipee Watershed Coalition is a partnership of municipal officials, community and business leaders, and other concerned citizens. Its mission is to sustain and protect shared resources through cooperative natural resource-based planning.”***



# Effingham Town Data

<b>POPULATION</b>	
2005 Census	1,425
Population Growth: 1990-2005	51.4%
Density (Persons per Square Mile)	36.7
OSP Estimated Population: 2025	1,980
Estimated Growth: 2000-2025	38.9%

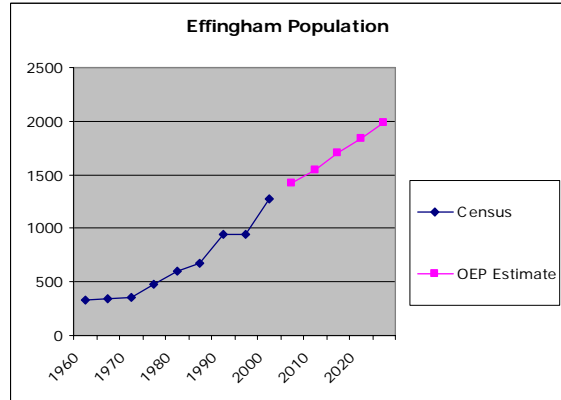

<b>GEOGRAPHY</b>		<b>HOUSING</b>		
Total Size	39.93	Sq. Miles	Total Housing Units	912
Land Area	24,878	Acres		
Surface Waters	678	Acres	Owner Occupied	396 (50%)
Shoreline of Great Ponds	3.16	Miles	Renter Occupied	94 (12%)
Protected Land	4,645	Acres (19%)		
Current Use	10,123	Acres (41%)	Seasonal	
Forested land	20,868	Acres (84%)	Vacant	260 (33%)
Tree farms (10)	1,863	Acres		41 (5%)
Water supply land	5,488	Acres	Manufactured	
Area of EPA High Value Wetlands	1,044	Acres	Multi family homes	133 (15%)
Number of Rare Species and Natural Communities	5			47 (5%)

<b>NH's Changing Landscape</b>		<b>Wildlife Habitat Land Cover</b>		
				% of total
		Acres		
Land Value Per Acre - 2003	\$1,424	Peatlands	1,850	7.1%
Acres of Important Forest Soils	16,424	Wet Meadow/Shrub Wetland	680	2.6%
% of Municipality Important Forest Soils	66.2%	Forest Floodplain	1,700	6.5%
Acres of Protected Important Forest Soils	2,462	Grasslands	87	0.3%
Acres of Prime Agricultural Soil	195	Pine Barrens	588	2.2%
% of Municipality Prime Agricultural Soils	0.8%	Cliffs	0	0.0%
Acres of Protected Prime Agricultural Soils	67.8	Rocky Ridges & Talus Slopes	0	0.0%
Acres of Prime White Pine Soil	4,437	High-Elevation Spruce Fir	0	0.0%
% of Municipality Prime White Pine Soil	17.9%	Lowland Spruce-Fir	169	0.6%
Acres of Protected Prime White Pine Soils	1,245	Northern Hardwood-Conifer	288	1.1%
NWI Acres	4,095	Hemlock-Hardwood-Pine	20,876	79.6%
% Municipality NWI	16.5%			
Protected NWI Acres 2004	1,151			
High Yield Aquifer	3,756			
Wellhead Protection Area	4,503			
% Protected Total Water Supply	23.5%			
Population Served by Community Water Supplies	520			

# Freedom Town Data

<b>POPULATION</b>	
2005 Census	1,431
Population Growth: 1990-2005	49.6 %
Density (Persons per Square Mile)	41.3
OSP Estimated Population: 2025	1,980
Estimated Growth: 2000-2025	39.0 %

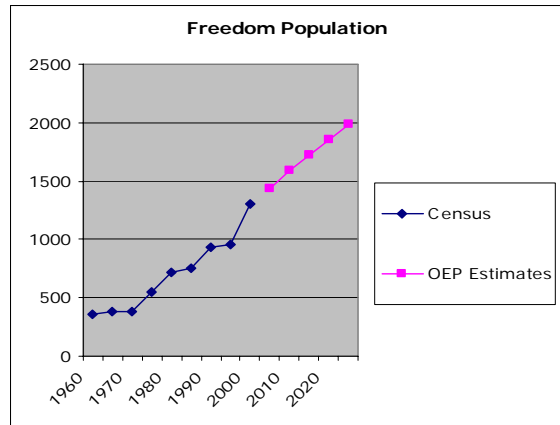

<b>GEOGRAPHY</b>			<b>HOUSING</b>		
Total Size	37.9	Sq. Miles	Total Housing Units	1,581	
Land Area	22,077	Acres	Owner Occupied	536	(38%)
Surface Waters	2,185	Acres	Renter Occupied	66	(5%)
Shoreline of Great Ponds	22.52	Miles	Seasonal	771	(55%)
Protected Land	1,876	Acres (9%)	Vacant	33	(2%)
Current Use	10,871	Acres (49%)	Manufactured	132	(8%)
Forested land	18,133	Acres (82%)	Multi family homes	105	(7%)
Tree farms (10)	810	Acres			
Water supply land	4,435	Acres			
Area of EPA High Value Wetlands	0	Acres			
Number of Rare Species and Natural Communities	27				

<b>NH's Changing Landscape</b>		<b>Wildlife Habitat Land Cover</b>		
			Acres	% of total
Land Value Per Acre - 2003	\$5,893	Peatlands	83	0.4%
Acres of Important Forest Soils	14,723	Wet Meadow/Shrub Wetland	468	2.1%
% of Municipality Important Forest Soils	66.7%	Forest Floodplain	568	2.6%
Acres of Protected Important Forest Soils	1,336	Grasslands	529	2.4%
Acres of Prime Agricultural Soil	56	Pine Barrens	1,853	8.4%
% of Municipality Prime Agricultural Soils	0.3%	Cliffs	0	0.0%
Acres of Protected Prime Agricultural Soils	0.0	Rocky Ridges & Talus Slopes	2	0.0%
Acres of Prime White Pine Soil	4,542	High-Elevation Spruce Fir	0	0.0%
% of Municipality Prime White Pine Soil	20.6%	Lowland Spruce-Fir	160	0.7%
Acres of Protected Prime White Pine Soils	536	Northern Hardwood-Conifer	191	0.9%
NWI Acres	683	Hemlock-Hardwood-Pine	18,303	82.6%
% Municipality NWI	3.1%			
Protected NWI Acres 2004	128			
High Yield Aquifer	3,082			
Wellhead Protection Area	2,552			
% Protected Total Water Supply	8.0%			
Population Served by Community Water Supplies	908			

# Madison Town Data

<b>POPULATION</b>	
2005 Census	2,242
Population Growth: 1990-2005	25.8 %
Density (Persons per Square Mile)	58.1
OSP Estimated Population: 2025	2,970
Estimated Growth: 2000-2025	32.5 %

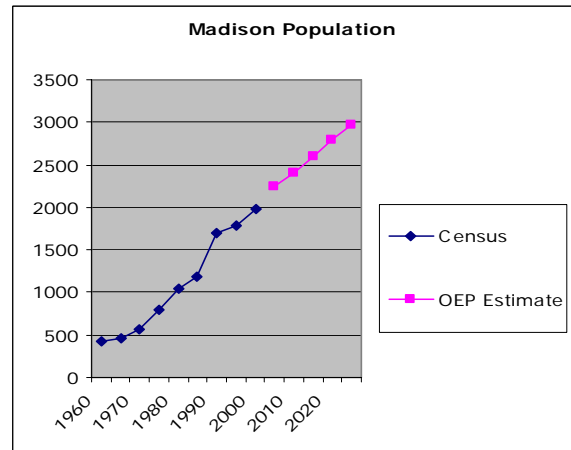

<b>GEOGRAPHY</b>		<b>HOUSING</b>		
Total Size	40.9	Sq. Miles	Total Housing Units	1,857
Land Area	24,766	Acres		
Surface Waters	1,391	Acres	Owner Occupied	633 (40%)
Shoreline of Great Ponds	18.96	Miles	Renter Occupied	144 (9%)
Protected Land	2,280	Acres (9%)		
Current Use	15,146	Acres (61%)	Seasonal	765 (48%)
Forested land	20,037	Acres (81%)	Vacant	47 (3%)
Tree farms (10)	2,221	Acres		
Water supply land	4,896	Acres	Manufactured	80 (4%)
Area of EPA High Value Wetlands	113	Acres	Multi family homes	99 (5%)
Number of Rare Species and Natural Communities	38			

<b>NH's Changing Landscape</b>		<b>Wildlife Habitat Land Cover</b>		
			Acres	% of total
Land Value Per Acre - 2003	\$5,013	Peatlands	260	1.1%
Acres of Important Forest Soils	17,569	Wet Meadow/Shrub Wetland	714	3.1%
% of Municipality Important Forest Soils	71.3%	Forest Floodplain	0	0.0%
Acres of Protected Important Forest Soils	1,477	Grasslands	318	1.4%
Acres of Prime Agricultural Soil	20	Pine Barrens	953	4.1%
% of Municipality Prime Agricultural Soils	0.1%	Cliffs	2	0.0%
Acres of Protected Prime Agricultural Soils	0.0	Rocky Ridges & Talus Slopes	84	0.4%
Acres of Prime White Pine Soil	3,631	High-Elevation Spruce Fir	0	0.0%
% of Municipality Prime White Pine Soil	14.7%	Lowland Spruce-Fir	175	0.8%
Acres of Protected Prime White Pine Soils	589	Northern Hardwood-Conifer	122	0.5%
NWI Acres	1,308	Hemlock-Hardwood-Pine	20,499	88.6%
% Municipality NWI	5.3%			
Protected NWI Acres 2004	119			
High Yield Aquifer	3,544			
Wellhead Protection Area	1,984			
% Protected Total Water Supply	12.2%			
Population Served by Community Water Supplies	975			

# Ossipee Town Data

<b>POPULATION</b>	
2005 Census	4,561
Population Growth: 1990-2005	35.5 %
Density (Persons per Square Mile)	64.5
OSP Estimated Population: 2025	6,320
Estimated Growth: 2000-2025	38.5 %

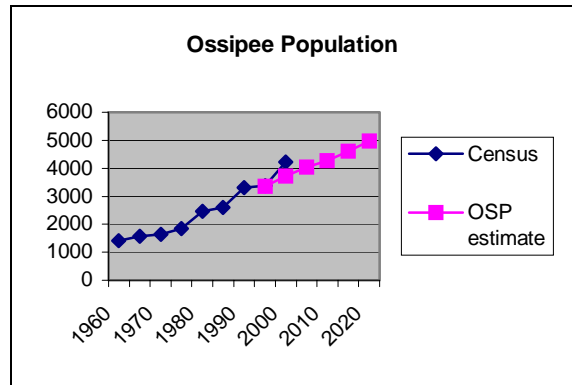

<b>GEOGRAPHY</b>		<b>HOUSING</b>		
Total Size	75.3	Sq. Miles	Total Housing Units	3,100
Land Area	45,376	Acres		
Surface Waters	2,793	Acres	Owner Occupied	1,323 (48%)
Shoreline of Great Ponds	23.66	Miles	Renter Occupied	349 (13%)
Protected Land	8,139	Acres (18%)		
Current Use	22,679	Acres (50%)	Seasonal	920 (34%)
Forested land	36,377	Acres (80%)	Vacant	150 (5%)
Tree farms (10)	6,970	Acres		
Water supply land	11,692	Acres	Manufactured	553 (18%)
Area of EPA High Value Wetlands	901	Acres	Multi family homes	232 (7%)
Number of Rare Species and Natural Communities		37		

<b>NH's Changing Landscape</b>		<b>Wildlife Habitat Land Cover</b>		
		<u>Acres</u>		<u>% of total</u>
Land Value Per Acre - 2003	\$7,373	Peatlands	1,353	3.0%
Acres of Important Forest Soils	30,014	Wet Meadow/Shrub Wetland	1,445	3.3%
% of Municipality Important Forest Soils	66.6%	Forest Floodplain	2,374	5.3%
Acres of Protected Important Forest Soils	3,859	Grasslands	323	0.7%
Acres of Prime Agricultural Soil	1,091	Pine Barrens	1,197	2.7%
% of Municipality Prime Agricultural Soils	2.4%	Cliffs	0	0.0%
Acres of Protected Prime Agricultural Soils	154.8	Rocky Ridges & Talus Slopes	50	0.1%
Acres of Prime White Pine Soil	6,755	High-Elevation Spruce Fir	0	0.0%
% of Municipality Prime White Pine Soil	15.0%	Lowland Spruce-Fir	460	1.0%
Acres of Protected Prime White Pine Soils	716	Northern Hardwood-Conifer	774	1.7%
NWI Acres	4,089	Hemlock-Hardwood-Pine	36,470	82.1%
% Municipality NWI	9.0%			
Protected NWI Acres 2004	1,107			
High Yield Aquifer	10,154			
Wellhead Protection Area	5,105			
% Protected Total Water Supply	24.6%			
Population Served by Community Water Supplies	2,249			

# Sandwich Town Data

<b>POPULATION</b>	
2005 Census	1,359
Population Growth: 1990-2005	22.5 %
Density (Persons per Square Mile)	14.9
OSP Estimated Population: 2025	1,830
Estimated Growth: 2000-2025	34.7 %

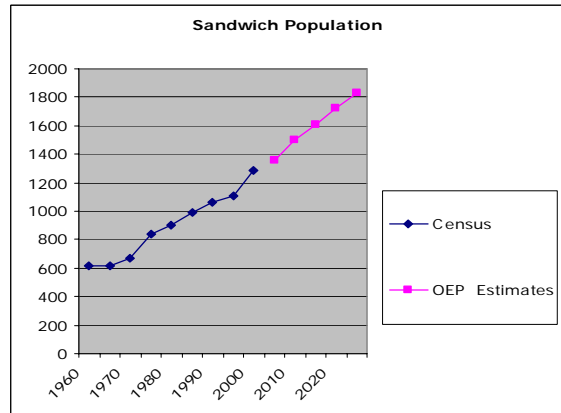

<b>GEOGRAPHY</b>		<b>HOUSING</b>	
Total Size	94.1 Sq. Miles	Total Housing Units	1049
Land Area	58,394 Acres		
Surface Waters	1,856 Acres	Owner Occupied	451 (47%)
Shoreline of Great Ponds	29.95 Miles	Renter Occupied	113 (12%)
Protected Land	20,813 Acres (36%)		
Current Use	22,233 Acres (38%)	Seasonal	360 (37%)
Forested land	52,079 Acres (89%)	Vacant	41 (4%)
Tree farms (10)	7,477 Acres		
Water supply land	1,534 Acres	Manufactured	28 (3%)
Area of EPA High Value Wetlands	185 Acres	Multi family homes	51 (4%)
Number of Rare Species and Natural Communities	37		

<b>NH's Changing Landscape</b>		<b>Wildlife Habitat Land Cover</b>		
			<u>Acres</u>	<u>% of total</u>
Land Value Per Acre - 2003	\$2,346	Peatlands	748	1.3%
Acres of Important Forest Soils	39,820	Wet Meadow/Shrub Wetland	1,940	3.2%
% of Municipality Important Forest Soils	68.5%	Forest Floodplain	587	1.0%
Acres of Protected Important Forest Soils	13,225	Grasslands	878	1.5%
Acres of Prime Agricultural Soil	523	Pine Barrens	0	0.0%
% of Municipality Prime Agricultural Soils	0.9%	Cliffs	0	0.0%
Acres of Protected Prime Agricultural Soils	142.0	Rocky Ridges & Talus Slopes	1,916	3.2%
Acres of Prime White Pine Soil	2,169	High-Elevation Spruce Fir	1,538	2.6%
% of Municipality Prime White Pine Soil	3.7%	Lowland Spruce-Fir	7,003	11.7%
Acres of Protected Prime White Pine Soils	213	Northern Hardwood-Conifer	9,219	15.4%
NWI Acres	3,291	Hemlock-Hardwood-Pine	35,940	60.1%
% Municipality NWI	5.6%			
Protected NWI Acres 2004	805			
High Yield Aquifer	1,303			
Wellhead Protection Area	219			
% Protected Total Water Supply	1.9%			
Population Served by Community Water Supplies	0			

# Tamworth Town Data

<b>POPULATION</b>	
2005 Census	2,516
Population Growth: 1990-2005	13.1%
Density (Persons per Square Mile)	42.2
OSP Estimated Population: 2025	3,620
Estimated Growth: 2000-2025	43.9%

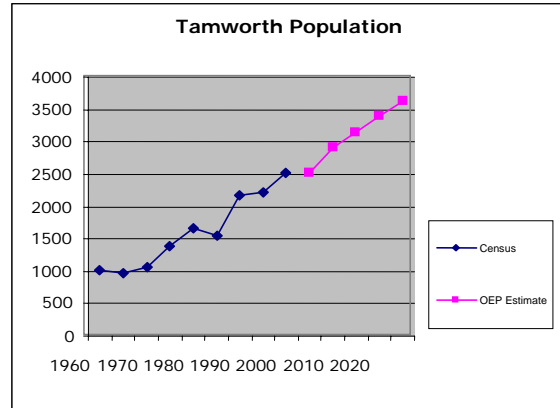

<b>GEOGRAPHY</b>		<b>HOUSING</b>			
Total Size	60.6 sq. miles	Total Housing Units	1,745		
Land Area	38,289 acres				
Surface Waters	523 acres	Owner Occupied	791	(48%)	
Shoreline of Great Ponds	10.17 miles	Renter Occupied	283	(17%)	
Protected Land	12,906 acres (34%)				
Current Use	22,132 acres (58%)	Seasonal	526	(32%)	
Forested land	31,788 acres (83%)	Vacant	62	(4%)	
Tree farms (10)	7,657 acres				
Water supply land	6,451 acres	Manufactured	184	(11%)	
Area of EPA High Value Wetlands	85 acres	Multi family homes	196	(11%)	
Number of Rare Species and Natural Communities	20				

<b>NH's Changing Landscape</b>		<b>Wildlife Habitat Land Cover</b>		
			<u>Acres</u>	<u>% of total</u>
Land Value Per Acre - 2003	\$2,215	Peatlands	264	.07%
Acres of Important Forest Soils	27,709	Wet Meadow/Shrub Wetland	547	1.4%
% of Municipality Important Forest Soils	72.7%	Forest Floodplain	27,709	4.7%
Acres of Protected Important Forest Soils	8,015	Grasslands	1,635	4.3%
Acres of Prime Agricultural Soil	671	Pine Barrens	883	2.3%
% of Municipality Prime Agricultural Soils	1.8%	Cliffs		
Acres of Protected Prime Agricultural Soils	49.9	Rocky Ridges & Talus Slopes	70	0.2%
Acres of Prime White Pine Soil	5,964	High-Elevation Spruce Fir	5	0.0%
% of Municipality Prime White Pine Soil	15.6%	Lowland Spruce-Fir	2,939	7.7%
Acres of Protected Prime White Pine Soils	1,576	Northern Hardwood-Conifer	2,461	6.4%
NWI Acres	1,494	Hemlock-Hardwood-Pine	27,640	72.3%
% Municipality NWI	3.9%			
Protected NWI Acres 2004	512			
High Yield Aquifer	5,162			
Wellhead Protection Area	164			
% Protected Total Water Supply	17.4%			
Population Served by Community Water Supplies	836			

# Ossipee Watershed Coalition Natural Resource Planning Guide Town Statistics Data Sources

## Population

*Population Estimates*, State Data Center Library, NH Office of Energy and Planning, September 2006

*2005 Household Estimates for NH Cities and Towns*, NH Office of Energy & Planning, September 2006

*Historical OEP Estimate Data*, State Data Center Library, NH Office of Energy & Planning

## Geography

*New Hampshire's Changing Landscape 2005 Update*, Society for the Protection of New Hampshire's Forests

*2006 Report of Land in Current Use*, NH Department of Revenue Administration

*Tree Farms in New Hampshire*, NH Tree Farm Program, August 2000

Shoreland Waterbody Results, OneStop Data Retrieval, NH DES

## Housing

*Current Estimates and Trends in NH Housing Supply – Update 2005*, NH Office of Energy & Planning, November 2006

*2005 Household Estimates for NH Cities and Towns*, NH Office of Energy & Planning, September 2006

American Fact Finder, US Census 2000, US Census Bureau,

## Wildlife Habitat Land Cover

Wildlife Habitat Land Cover, *Wildlife Action Plan*, NH Fish & Game Department, October 2005

## NH Changing Landscape

*New Hampshire's Changing Landscape 2005 Update*, Society for the Protection of New Hampshire's Forests

**Ossipee Watershed Coalition  
Natural Resource Planning Guide  
Chapter IV: Geology of the Ossipee Aquifer**

**I. Introduction**

The Ossipee Aquifer is the largest stratified drift aquifer in the State of New Hampshire (Moore, 1995). The aquifer covers 47,610 acres within a 213,000 acre watershed that is drained by the Bearcamp and Ossipee rivers. The watershed (Figure 1) extends from the summits of the Sandwich Range in the north, to the western part of the Ossipee Mountains in the west, to the Pine River watershed to the south, to the outlet of Ossipee Lake to the east. There is 3630 ft of relief from the highest point, Whiteface Mountain (4020 ft) to the lowest point on the Ossipee River (390 ft).

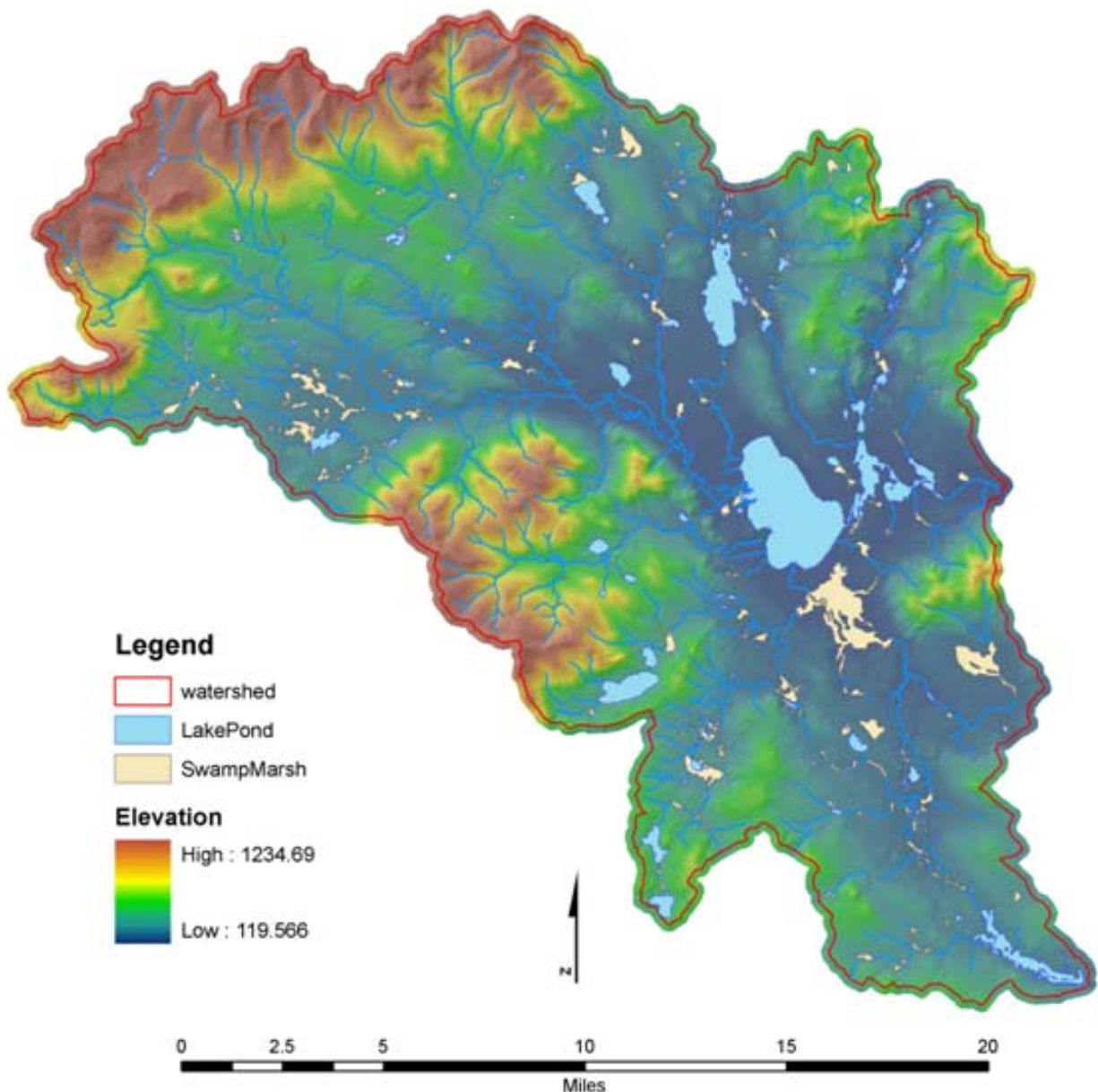

**Chapter IV Figure 1.** Digital Elevation Model (DEM) of the Ossipee Aquifer watershed.



The landscape has been sculpted by geologic processes over many millions of years, but the greatest impact has come from Pleistocene glaciations. The Pleistocene, a period characterized by intermittent glacial advances and retreats, began approximately 2 million years ago and ended about the time of the retreat of the last glacier, approximately 14,000 years ago. Much of the form of the landscape that we see today was created during this period. The Ossipee Aquifer itself was created by glaciofluvial processes associated with the retreat of the last continental ice.

## II. Bedrock Geology

The Ossipee Aquifer lies within the Central Maine terrane characterized by metamorphosed sediments originally deposited in a marine basin from the Silurian through the Early Devonian time. These marine sediments were subsequently metamorphosed during a deformation period that coincided with the formation of intrusive rocks of the New Hampshire Plutonic Series. The principle metamorphic rock in the area is mica schist of the Littleton Formation. Plutonic rocks include granites and pegmatites. Later, during the Jurassic there was a second period of igneous activity that emplaced the more granites (Conway Granite) and formed the classic ring dike of the Ossipee Mountains.(Wilson, 1971)

## III. Surficial Geology - Features

Glacial and postglacial geologic processes have left a mantle of unconsolidated material overlying most of the bedrock surface. These materials can be classified into two basic types, stratified drift and till. Till is unsorted, unstratified material that was deposited directly by the glacier. There are two different till units that occur in the watershed. The Upper Till (Figure 2) was deposited by the last glacier and is quite sandy, typically averaging 67 percent sand, 29 percent silt and 4 percent clay sized-material. The Lower Till (Figure 3) was deposited by an earlier glaciation and is texturally quite different, being much more clay rich. It tends to be very compact and is composed of 50 percent sand, 30 percent silt and 20 percent clay. A brown oxidized zone is sometimes found on top of a dark gray unoxidized zone. The oxidized zone represents the weathered soil profile that developed during the interglacial period between the glacial period when the Lower Till was deposited and the period when the Upper Till was deposited.



Chapter IV Figure 2. An exposure of sandy Upper Till near Tamworth.



**Chapter IV Figure 3.** Lower Till exposed at the northern edge of the Ossipee Mountains in Tamworth.

Generally, till is a poor aquifer as the poor sorting causes low porosity and permeability. However, the Upper Till often provides adequate amounts of groundwater to domestic wells. The Lower Till is essentially impermeable except for water that moves through fractures.

Sediments transported and deposited by rivers and streams are sorted, rounded and stratified by the fluvial processes. The resulting deposits range from coarse gravels to fine sands but all tend to be well sorted. These processes typically result in rather thick sequences of permeable sands and gravels (Figure 4). (Ayotte et al, 2003)



**Chapter IV Figure 4.** Modern meltwater deposits immediately downstream from the snout of the Herbert Glacier in southeast Alaska. Note the coarse, well-sorted gravel and braided streams.

The retreat of the last continental ice sheet released tremendous quantities of sediment-rich meltwater. These sediments were deposited in a variety of settings at and near the ice front as the glacier retreated through this region. The nature of the ice front was complex with a stagnation zone extending in front of the actively moving ice. Meltwater streams were flowing on top of, within, and under this ice. They deposited sediment through the stagnation zone and out in front of the ice and created a wide variety of geomorphic landforms. These landforms may be classified into either ice-contact or proglacial features. The ice-contact features were deposited in intimate association with the ice while the proglacial features were deposited beyond the ice front.

## A. Ice Contact Features

Ice contact features include; kames, kame terraces, kame deltas, and eskers. These features are similarly composed of well-sorted, stratified sands and gravels but can be differentiated morphologically.

### *Kame*

Kames are isolated hills of stratified sand and gravel. They were formed by a meltwater stream system flowing through the ice where deposition occurred in a few isolated areas. An example would be a depression on the surface of the ice that a meltwater stream filled with sediment. When the ice completely melts away, the sediment will be left as a small hill below where the depression was located in the ice.

### *Kame terrace*

A kame terrace is a feature that was formed on the side of a valley wall or mountain. It is created by a meltwater stream flowing along the margin of the ice between the valley wall or mountain side and glacial ice filling the bottom of the valley. The surface of the kame terrace is essentially the floodplain of the meltwater stream. When the ice melts the glacial ice side of the feature is removed and the floodplain is left as a terrace up on the valley side.

### *Esker*

An esker (Figure 5) is a sinuous, sometimes anastomosing ridge composed of stratified, sorted sands and gravel. It represents the channel of a meltwater stream that was cut into the ice. These channels are sometimes found as tunnels under the ice and the flow of the meltwater stream can thus be controlled by hydrostatic pressure, allowing them in some cases to actually flow uphill. The ice walls of the tunnel confine sediment deposited in the channel. As sediment fills the tunnel, frictional heat generated by the stream can cause roof melting which allows the river to continue to flow as the tunnel accumulates more and more sediment. When the ice eventually melts, the sediment is left behind as a ridge marking the pattern of the former meltwater stream.

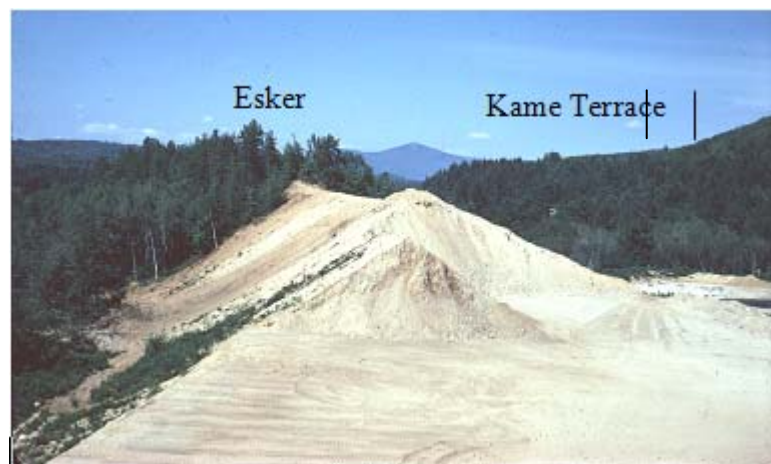

**Chapter IV Figure 5.** Esker being mined for its sand and gravel in Madison. Note the profile of a kame terrace on the valley side. Vertical line marks the upslope edge of the terrace.

## B. Proglacial Features

Proglacial features include, outwash, lake basins and deltas, all formed by meltwater streams flowing away from the ice front.

### *Outwash Plain*

An outwash plain (Figure 6) is an extensive, nearly flat surface, that represents the old floodplain of an extensive series of braided streams that deposited sediment out in front of the retreating glacier. Outwash sediments are sorted and stratified and range from coarse sands and gravels near the ice front to medium to fine sands away from the ice front. They generally permeable and thick and thus make excellent aquifers.



**Chapter IV Figure 6.** Sand pit in outwash plain in “the plains” area Between Ossipee Lake and Silver Lake. This outwash plain lies in the center of the northern part of the Ossipee Aquifer.

### *Lake Basin*

A lake basin is a nearly flat surface that represents the bottom of a pre-existing lake. Disruptions to drainage were common as ice and sediment frequently blocked channels and caused the formation of ice marginal lakes. Meltwater streams flowing into these lakes brought large volumes of sediment that varied seasonally. During the spring and summer melting of the glacier together with rain brought lots of sediment into the lake with much of the coarse material being quickly deposited. During the fall and winter cold temperatures caused the lakes to freeze over and discharge from the meltwater streams declined dramatically. During this time only the finest particles suspended in the water column were deposited on the lake bottom. This annual cycle caused a repeating sequence of coarser and finer sediments to be deposited. These annual couplets are called varves (Figure 7) and are characteristic of glacial lake sediments. Although varves are well-sorted, the winter clay layer in particular is very fine grained and thus has very low permeability so this deposit has low permeability especially in the vertical direction and they often act as a confining bed to a confined aquifer.



**Chapter IV Figure 7.** Varved clay. This glacial lake sediment consists of alternating layers of clay and silty sand. Each clay-silty sand couplet represents one year of sediment accumulation in the lake.

### *Delta*

A delta is a feature created when a river enters a standing body of water such as a lake. The loss of a moving current leads to sediment deposition at the stream/lake interface. The high sediment load of the meltwater streams resulted in rapid formation of deltas with a specific structure. Bedload material deposited at the mouth of the river avalanches down to the lake bottom creating inclined foreset beds. The angle of inclination corresponds to the angle of repose for sand in water. Continued deposition of sediment causes the delta to grow out into the lake so that the foreset beds accumulate on top of the lake bottom sediments which in the case of a glacial lake will be varved clay. As the delta grows out into the lake, the streams feeding it must maintain a gradient in order to continue to flow. Deposition of coarser material on the delta surface, in the form of topset beds, builds up this surface, maintaining the gradient to the lake. In cross-section, a delta will have coarse topset beds overlying foreset sands which in turn overlie varved clay (Figure 7). The elevation of the topset/foreset contact approximately corresponds with the water level in the lake (Figure 8). Deltas generally make good aquifers and their position in the landscape sometimes make them critical recharge areas.

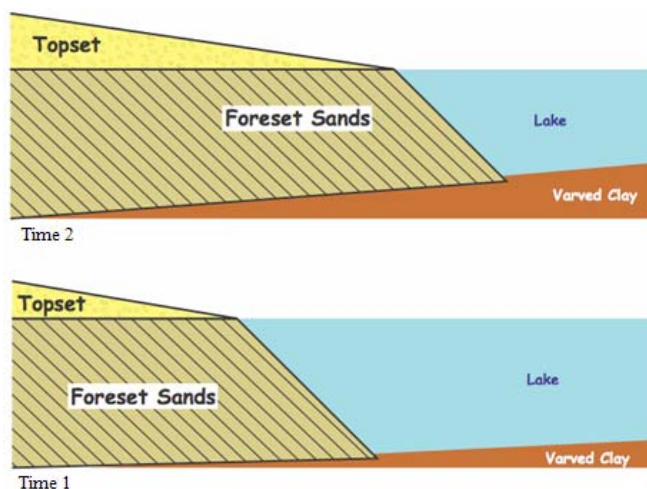

**Chapter IV Figure 7.** Diagram showing the cross-sectional structure of an aggrading delta. As the delta extends into the lake it builds on top of varved clay lake sediments



**Chapter IV Figure 8.** Exposure of delta formed into Glacial Lake Ossipee. Note the contact between the topset gravels and foreset sands that marks the elevation of the water surface of the glacial lake.

### *Modern Floodplain*

Modern streams are transporting and depositing sediments in a somewhat similar manner to the glacial meltwater streams. The big difference is that modern streams do not have the high discharge and sediment load of the meltwater streams, but nonetheless modern streams have, in some areas, formed floodplains. Modern floodplain sediments tend to be much finer grained than meltwater stream deposits so they are generally not as productive aquifers.

## **IV. Formation of the Ossipee Aquifer**

The Ossipee Aquifer is a group of glacial meltwater stream deposits that were all formed during the retreat of the last continental ice. A detailed analysis of the glacial deposits in this area can be found in reports on the Surficial Geology of the Ossipee Lake Quadrangle (Newton, 1974) and Surficial Geology of the Wolfeboro-Winnepesaukee Area (Goldthwait, 1968b). Portions of these surficial geologic maps are provided at the end of this chapter. The main part of the aquifer extends from Pine River Pond to the south, to Silver Lake in the north (Figure 9). The aquifer is made up of a complex series of meltwater deposits that were not all formed at the same time but were instead formed in sequence. Since the ice front retreated from the south to the north, features at the south end of the aquifer formed first while those to the north formed later.

The portion of the aquifer south of Ossipee Lake is dominated by the Pine River Esker system. This is a series of eskers, kames and kame terraces that formed as the ice front began to retreat across the area. The Pine River Esker system is a south flowing hydrostatic system that drained water from ice covering the entire region (Goldthwait, 1968a). The 40 to 120 foot high esker ridge extends nearly 14 miles adjacent to the now north flowing Pine River. The adjoining kames and kame terraces together with the esker create a belt of meltwater deposits up to 3 miles wide. These thick permeable sands and gravels form a nearly continuous aquifer that covers over 18,000 acres of the southern part of the watershed.

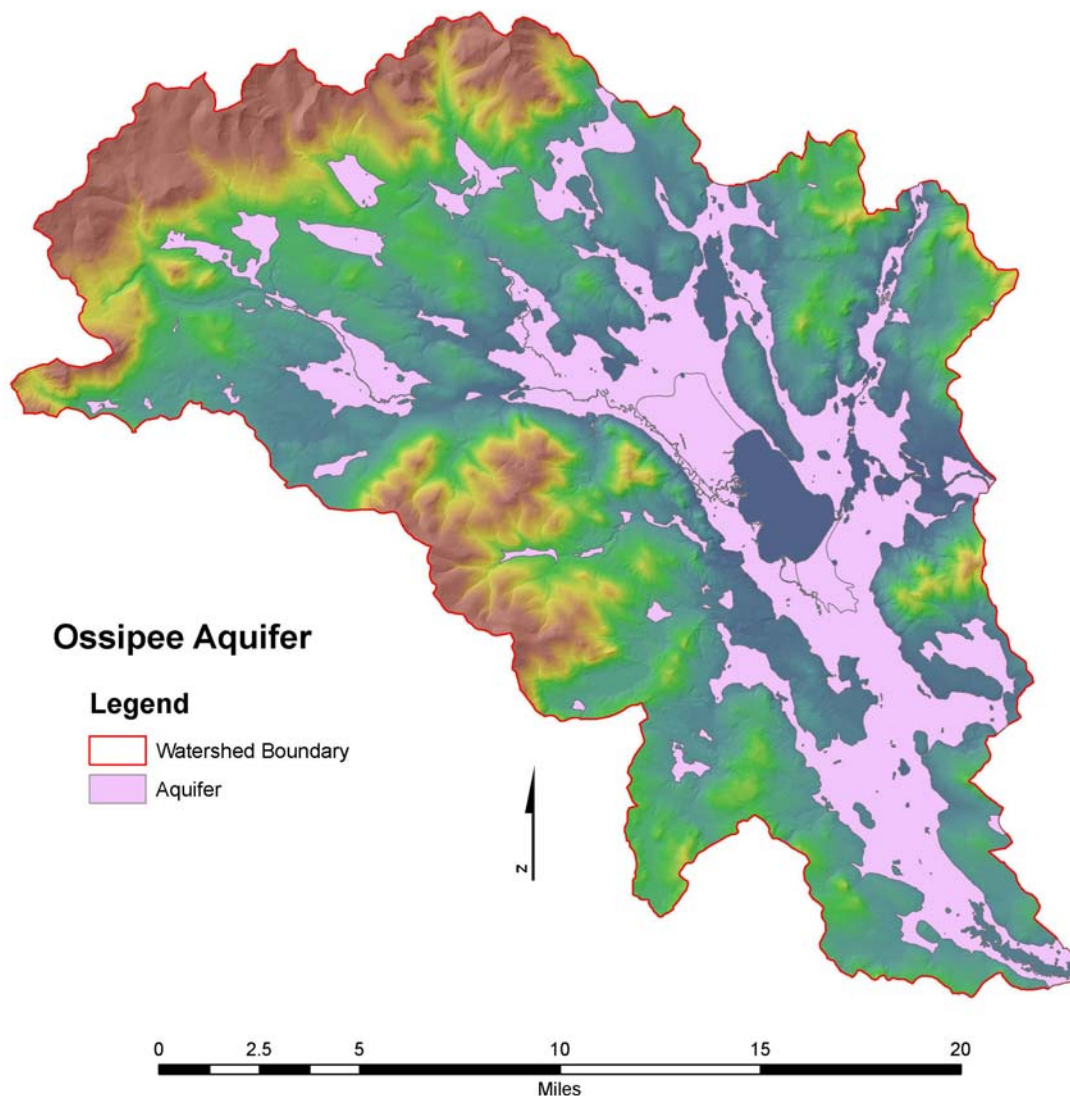

**Chapter IV Figure 9.** Map of the Ossipee Aquifer.

Thinning and retreat of the ice front led to the abandonment of meltwater flow through the Pine River Esker System. The ice was no longer thick enough to maintain southward upslope hydrostatic flow. Meltwater began exiting the area eastward through a channel on the north side of Green Mountain. At this time, ice and sediment blocked the area where today the Ossipee River flows out of Berry Bay. This sediment and ice dam caused the formation of a glacial lake that had a surface elevation of approximately 460 ft, nearly 60 ft higher than the current level of Ossipee Lake. The lake was bounded by glacial ice to the north and east and the higher land of the Ossipee Mountains to the west and the north flowing Pine River watershed to the south.

Coarse sands and gravels were deposited where meltwater streams flowed from the ice front directly into the lake. If the ice front remained stationary long enough, these meltwater deposits built up to the lake surface forming an ice marginal delta. Once the ice retreated, the delta was separated from its meltwater source, and abandoned with little evidence preserved of the stream that formed it. In rare cases, an esker is found connected to the delta that shows the subglacial pattern of meltwater flow that fed the delta.

If the ice front did not remain stationary long enough to create an emergent delta, the meltwater sediments were instead deposited in the form of a coarse subaqueous fan. Continuous retreat of the ice front tends to cause these fans to merge into a semi-continuous layer across the lake bottom (Figure 10).

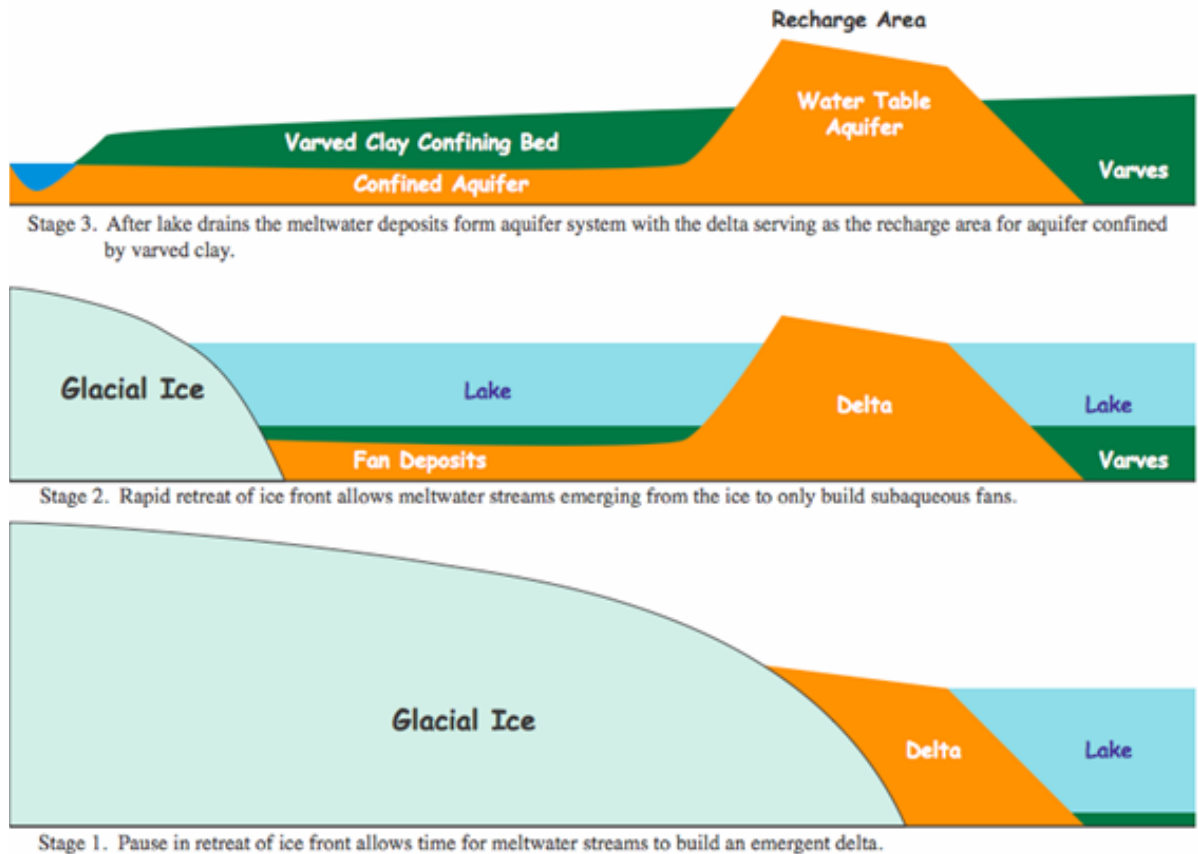

**Chapter IV Figure 10.** Diagram showing how sediments deposited in a glacial lake form a confined aquifer.

The series of kame deltas just south of Ossipee Lake indicate a pause in the retreat of the ice front in a manner equivalent to Stage 1 of Figure 10. At this time, Glacial Lake Ossipee was a small ice marginal lake extending from the ice front, marked by these kame deltas, southward into the lower part of the Pine River drainage system (Figure 11). The lake drained eastward through the channel at the base of Green Mountain. After this pause, the ice front appears to have rapidly retreated northward. While it is possible that a layer of gravel was deposited at the bottom of the glacial lake during this rapid retreat (equivalent to Stage 2 of figure 10), it is also possible that no gravel was deposited as most of the meltwater appears to have been diverted eastward through a well-developed esker system that flowed along the east side of Silver Lake, then to the area of Cooks Pond and on through the gap just east of Jackman Ridge. Meltwater from this system bypassed the ice marginal side of Glacial Lake Ossipee and emerged to form the outwash/delta deposits just north of Broad Bay.



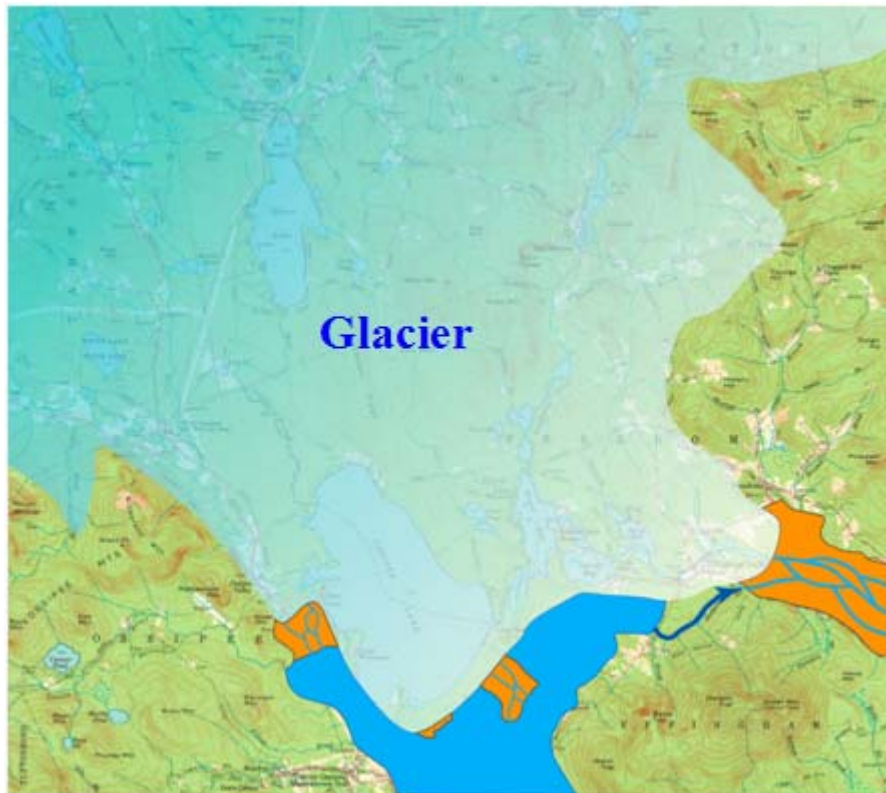

**Chapter IV Figure 11.** Early stage of Glacial Lake Ossipee showing the formation of 3 kame deltas at the ice front similar to that proposed in Stage 1 of Figure 10.

Continued thinning of the ice subsequently caused the lower part of this meltwater system to be abandoned and meltwater flowed southwest from the area of Silver Lake to form the very large outwash/delta complex in “The Plains” region between Silver Lake and Ossipee Lake. At this time, the ice front had retreated to a position that roughly corresponds to the south shore of Silver Lake (Figure 12). Meltwater flowing through stagnant ice north of the ice front created eskers kames and kame terraces that fill the valley between Silver Lake and Conway.

Eventually this meltwater system was also abandoned and the main flow of meltwater was directed eastward through the Saco River valley in the Conway area. At about this time the ice and sediment that dammed Glacial Lake Ossipee was eroded and lake level lowered to form present day Ossipee Lake. Silver Lake was formed as a remnant block of glacial ice that was buried in meltwater sediments that slowly melted to form a “kettle hole”. This occurred after the flow of meltwater was diverted so that the resulting depression in the land surface did not fill in with sediments but created a lake instead.

Kettle hole lakes are often surrounded by permeable sands and gravels and are therefore intimately connected to the surrounding groundwater system. When these lakes lack an outlet stream they are classified as seepage lakes in contrast to drainage lakes which have an outlet stream. Seepage lakes discharge excess water directly into the groundwater system.

The Ossipee Aquifer can be subdivided into 4 regions. The southern region includes the nearly continuous deposits of the Pine River Esker System covering about 18,000 acres. These deposits merge to the north with deposits of the Glacial Lake Ossipee outwash/delta system covering an additional 21,500 acres. These two regions make up the principle part of the contiguous aquifer.

Smaller isolated aquifers lie to the northwest (8,400 acres) and in the Ossipee Mountains (611 acres).

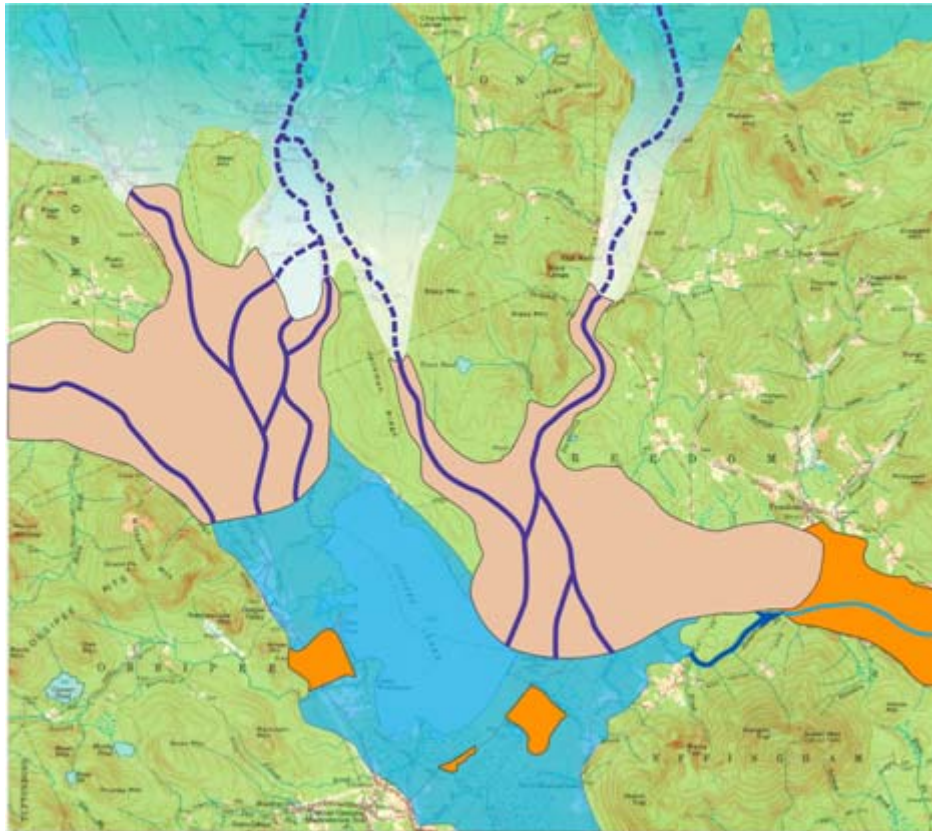

**Chapter IV Figure 12.** Formation of large outwash/delta deposits associated with Glacial Lake Ossipee. Brown areas represent of outwash or deltas being actively built into Glacial Lake Ossipee. Dashed blue lines indicate subglacial meltwater streams as indicated by esker systems.

## V. Groundwater Recharge in the Ossipee Aquifer

Groundwater flows from high areas of recharge to low areas of discharge. The high areas or recharge include primary recharge areas, which are essentially areas where the aquifer outcrops on the land surface, together with secondary recharge areas where groundwater is delivered to the aquifer from adjacent slopes that are covered by non-aquifer materials (Figure 13). Low areas of discharge include both streams and lakes. However, not all streams and lakes receive groundwater, in some cases they can lose water to the groundwater system and thus can also serve as a source of groundwater recharge (Figure 14). Since streams draining areas outside the primary and secondary recharge areas have the potential to recharge the aquifer when they pass over it, their watersheds are classified as tertiary recharge areas.

Soils in recharge areas are generally classified as “excessively drained” and include soil types such as the Adams, Colton, Windsor and Hinckly series. The high permeability of these soils causes maximum infiltration of rain and snowmelt.

The most important primary recharge areas are those that are located at the highest elevations and that have the thickest unsaturated zone. Unsaturated zone thickness is important as it provides space for temporary storage of infiltrated water. If the water table is near the land

surface, there is little available storage and precipitation cannot infiltrate into saturated soil but rather is forced to move as surface runoff. Therefore the low areas next to streams are generally not as important for groundwater recharge as the higher land away from the stream.

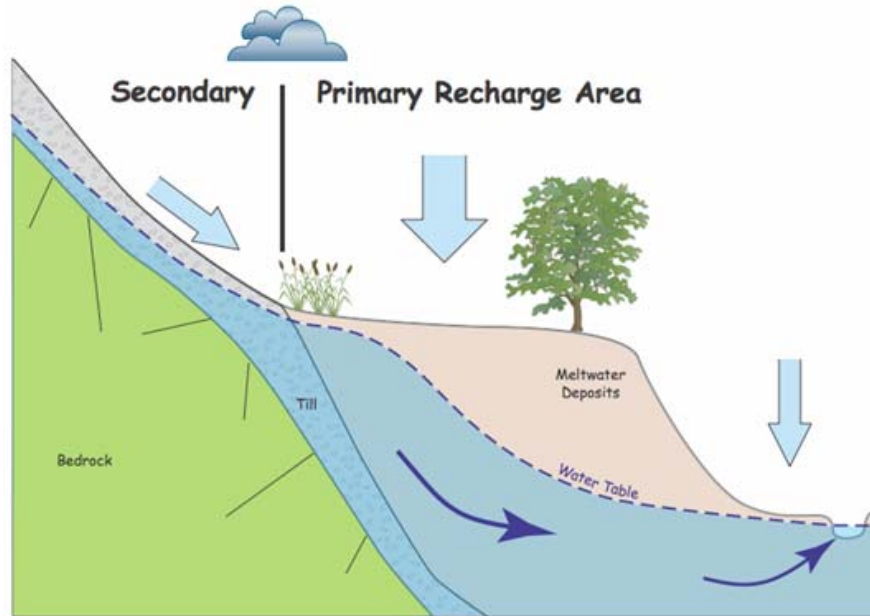

**Chapter IV Figure 13.** Cross section through Primary and Secondary Recharge area showing flow path of water through the aquifer system. The Secondary Recharge area feeds both surface and groundwater into the Primary Recharge Area where it is infiltrated into the aquifer. Groundwater flows from these high areas of recharge to low areas of discharge at streams and lakes.

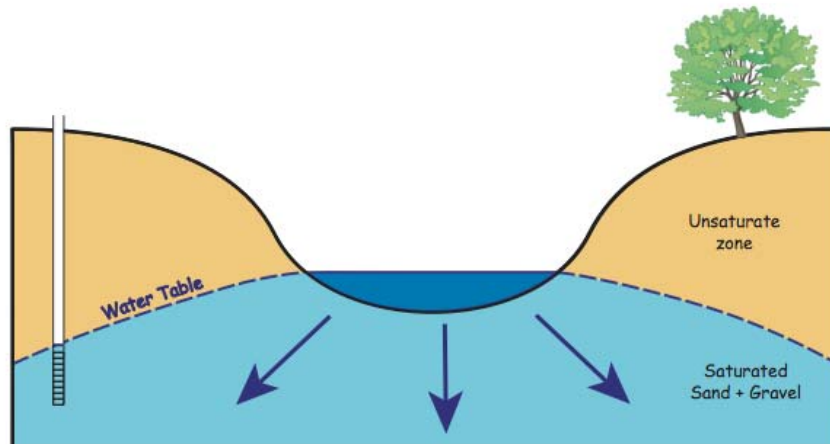

**Chapter IV Figure 14.** When the water level in the stream is higher than the water level in the aquifer, streamwater will infiltrate through the stream bottom into the groundwater system. Thus water generated within Tertiary Recharge Areas has the potential to infiltrate into the aquifer.

The slopes above the primary recharge areas can provide significant recharge to the aquifer. These slopes are typically steeper and covered with thinner, less permeable sediments such as glacial till. However all the water released from these secondary recharge areas is discharged directly to the primary recharge area in the form of either direct groundwater flow or surface water runoff. The surface water runoff collects at the change in slope that marks the beginning of the Primary Recharge Area where it forms temporary wetlands that feed water directly into the Primary Recharge Area.

Primary recharge areas in the Ossipee Aquifer occupy over 47,600 acres, covering about 22 percent of the watershed. Secondary Recharge Areas cover another 50,700 acres or 24 percent of the watershed and the remaining 114,700 acres (54 percent) classifies as Tertiary Recharge Area (Figure 15).

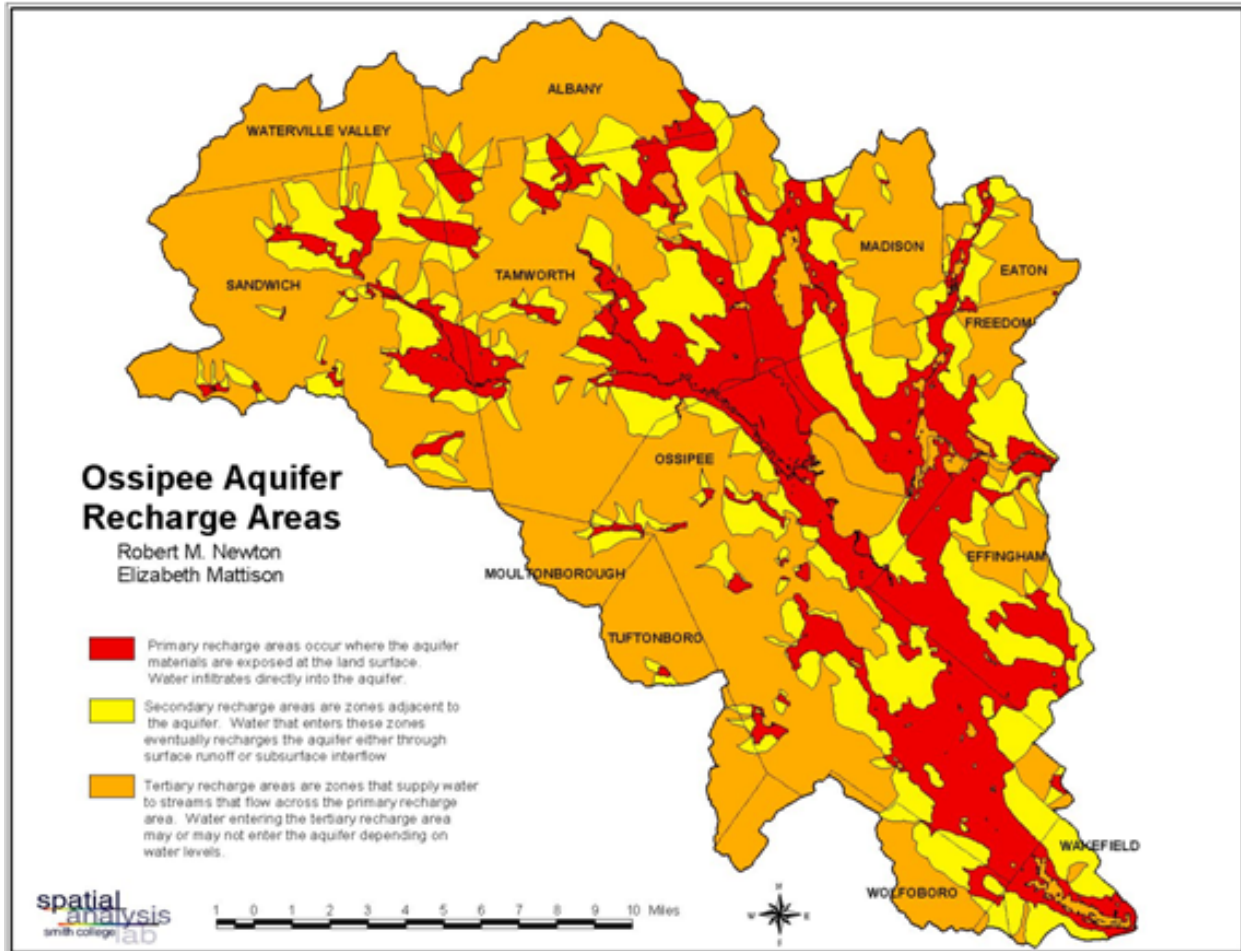

Chapter IV Figure 15. Map showing the classification of recharge areas in the Ossipee Aquifer.

## VI. Impact of Land Development

Aquifers formed from meltwater stream deposits are sensitive to developmental land use changes. Paving and building construction creates impermeable surfaces that reduce groundwater recharge. Septic tanks, leaky petroleum tanks, chemical spills, road salt application and applications of fertilizer, pesticides and herbicides can all severely affect groundwater quality.

It is critical that Best Management Practices (BMPs) be used in primary and secondary recharge areas to help mitigate the impact of development on the aquifer. For example, parking areas need to be paved, curbed and their runoff needs to pass through a pollutant separator (e.g. Stormceptor<sup>®</sup>) before entering an infiltration basin. In addition, certain activities such as those involving the use of toxic chemicals need to be restricted from the primary recharge areas.

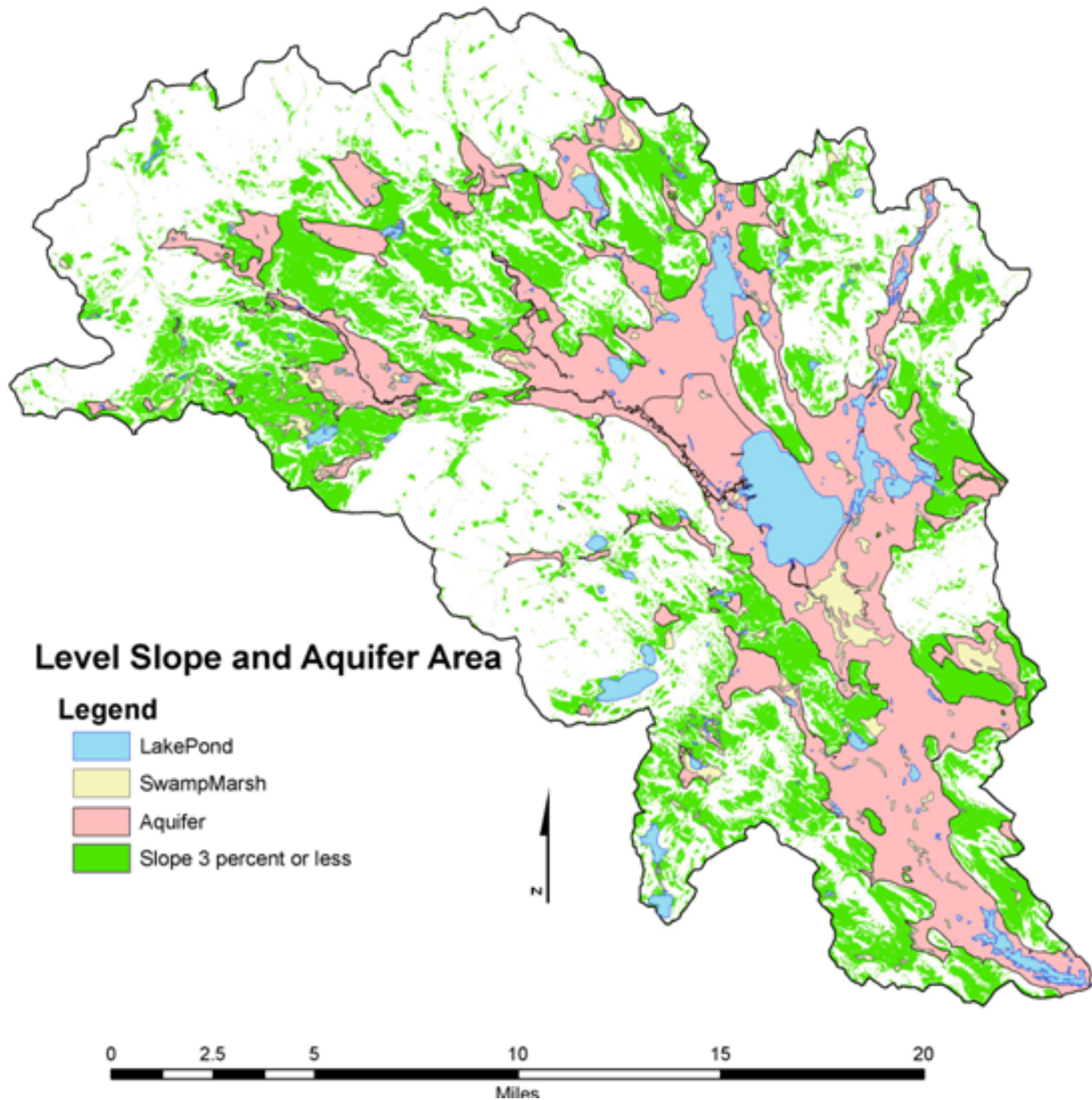

**Chapter IV Figure 16.** The aquifer covers almost half of the level or nearly level land (<3 percent slope) available in the watershed.

Unfortunately, the geomorphic processes that created the aquifer also created a landscape that has physical characteristics conducive to development. The flat slopes and very well drained soils of meltwater stream deposits are much sought after attributes for land developers. Approximately 47 percent of the watershed is level to nearly level land (< 3 percent slope) and of that almost half is occupied by the aquifer. If you add in secondary recharge areas, this increases to almost 70 percent. This creates a conflict between the need to protect the aquifer and the desire to increase economic development. In the long run economic development will only succeed as long as there is an abundance of good clean drinking water and this can only be maintained through careful development.

## References

Ayotte, J.D., Montgomery, D.L., Flanagan, S.M., and Robinson, K.W., 2003, Arsenic in groundwater in eastern New England: Occurrence, controls, and human health implications: *Environmental Science & Technology*, v. 37, p. 2075-2083.

Goldthwait, R.P., 1968a, Pine River esker system, New Hampshire: Special Paper - Geological Society of America, p. 267.

Goldthwait, R.P., 1968b, Surficial geology of the Wolfeboro-Winnepesaukee area, New Hampshire: .

Moore, R.B., 1995, Geohydrology and water quality of stratified-drift aquifers in the Saco and Ossipee River basins, east-central New Hampshire: *Water-Resources Investigations - U.S.Geological Survey*, .

Newton, R.M., 1974, Surficial geology of the Ossipee Lake Quadrangle, New Hampshire: .

Wilson, J.R., 1971, Bedrock geology of the Ossipee Lake area: Annual Meeting - New England Intercollegiate Geological Conference, Guidebook, v. 63, p. 64.

# Additional Reference Maps

Chapter IV Figure 17: Surficial geologic map of a portion of the Ossipee Lake Quadrangle

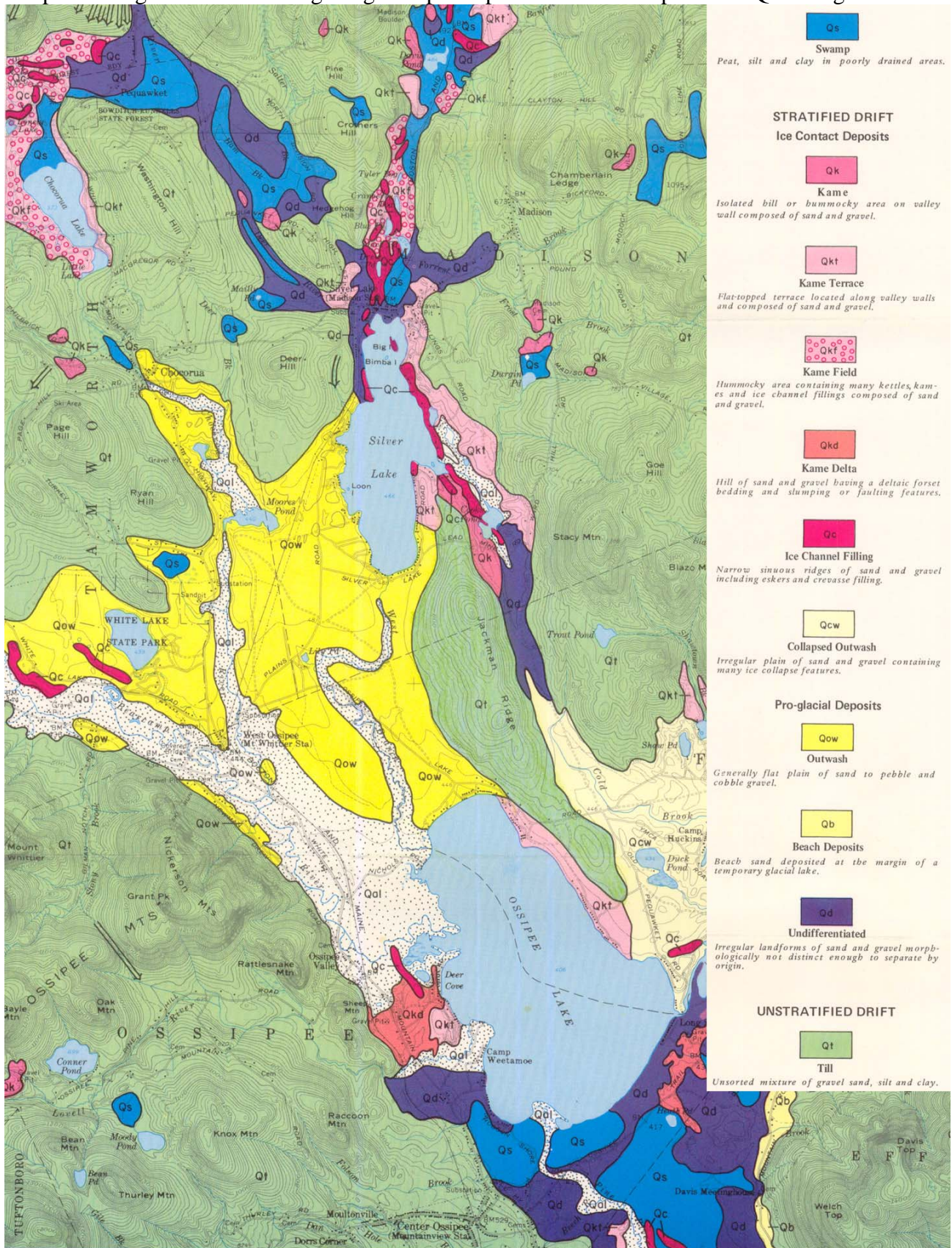

Chapter IV Figure 18: Surficial geologic map of a portion of the Wolfeboro Quadrangle

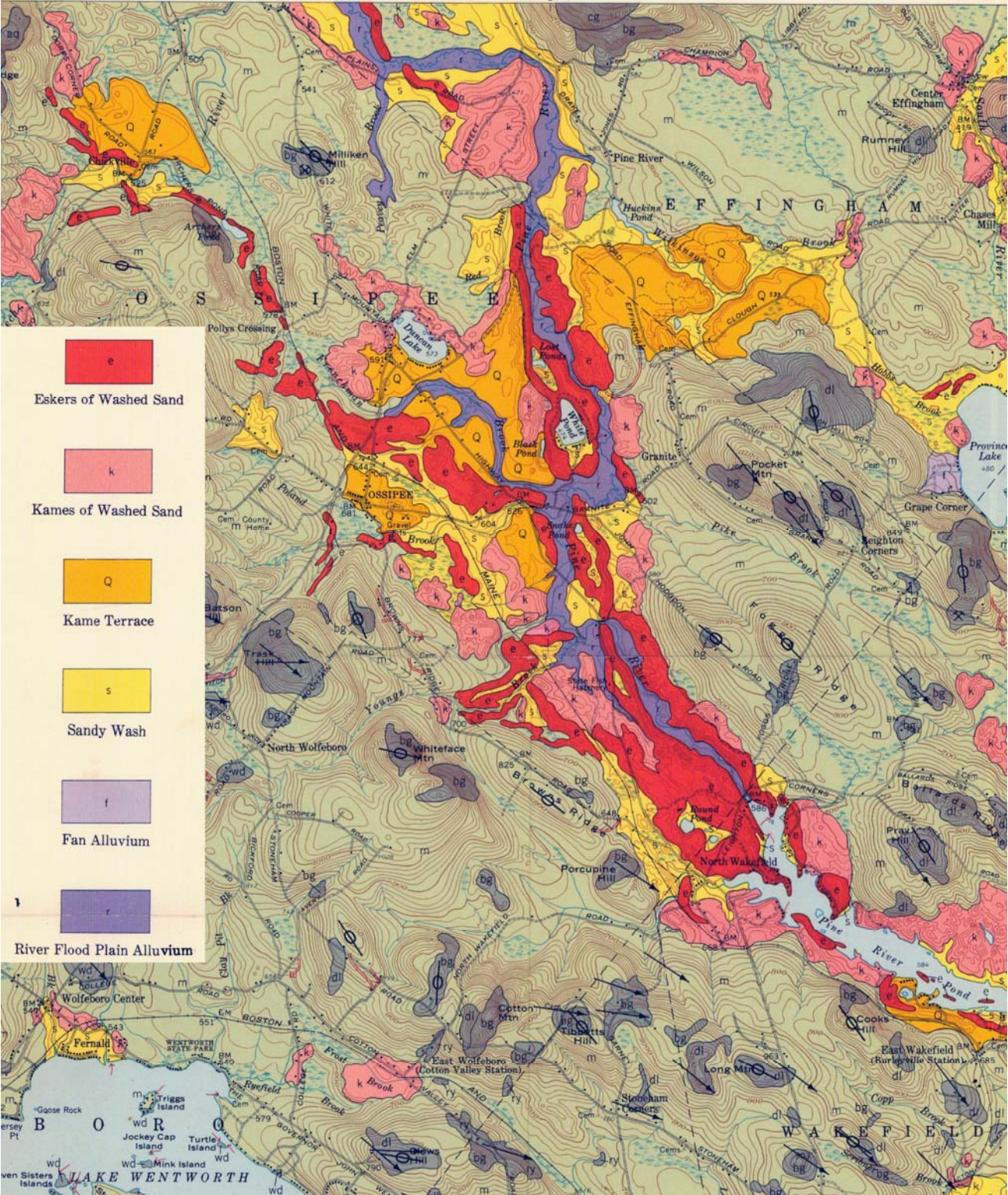



**Ossipee Watershed Coalition  
Natural Resources Planning Guide  
Chapter V- A.1 - Water Resources in the Ossipee Watershed**

**I. Introduction to the Importance of the Ossipee Watershed**

Water concerns are critical to residents of the Ossipee Watershed because both the quantity and quality of currently abundant sources fuel vital drinking water supplies and a tourist-based economy. Increased population, rapid residential and commercial development and expanded recreational use have put pressure and stress on the Watershed's water resources. As storm water from rain and melting snow travels across farms, fields, forestland, parking lots, highways and backyards, it picks up pollutants, eventually depositing them in surface waters, soils and groundwater. Thus, activities on the land, human and non-human, can impact the quality of our lakes, rivers and drinking water.

**II. Description of the Resource**

A *watershed* is the area of land that water runs across, through, and under on its way to the lowest point, often draining into a particular stream, river, marsh, or water body, such as Ossipee Lake. Large watersheds may be comprised of several smaller *subwatersheds*, each contributing a portion of the total watershed drainage. Similarly, adjacent watersheds, each with its own particular water body focus, may be combined to define a larger regional drainage *basin*, often associated with a major river or other large scale water feature.

The **Saco River Basin** (Figure 1) covers a 1,700 square mile area that includes 63 municipalities in New Hampshire and Maine. The Saco River starts in the White Mountains of New Hampshire, is joined in Cornish, Maine by the Ossipee River, and ends at Saco Bay on the Maine coast. Although much of the land bordering its surface waters is privately owned, the river itself has seen a dramatic increase in recreation and shoreline development in recent years.



**Chapter V-A.1 Figure 1:  
Saco River Basin Map**  
(map created by The Nature Conservancy)

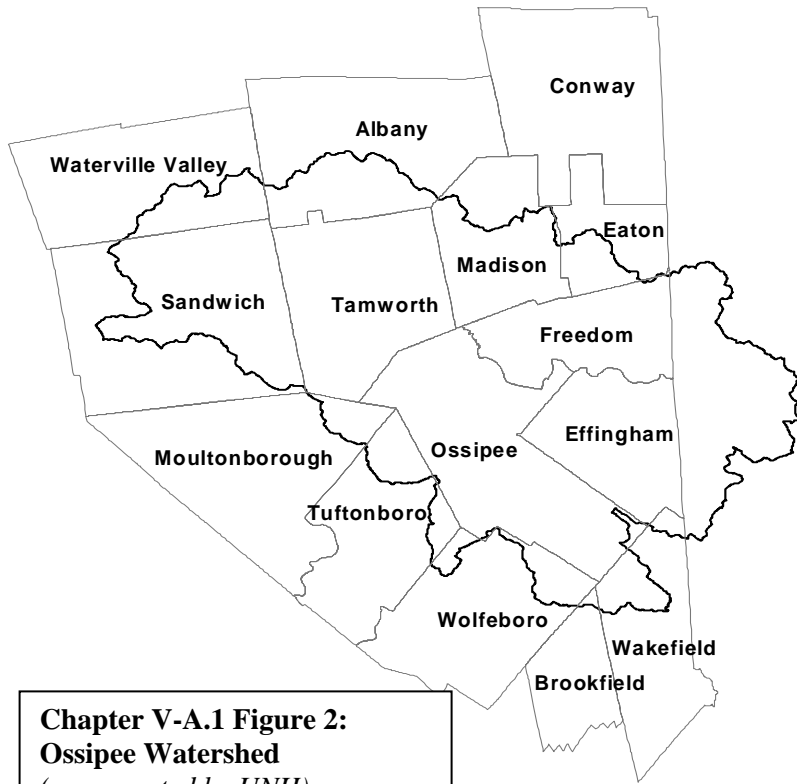

**Chapter V-A.1 Figure 2:  
Ossipee Watershed**  
*(map created by UNH)*

The **Ossipee Watershed** (Figure 2) is included within the Saco River Basin and comprises about 379 square miles in area located in Carroll and Grafton Counties, and York and Oxford Counties in Maine. It contains 82 lakes and ponds, and at its widest points, the watershed extends approximately 29 miles east and west and 23 miles north and south. Waters from the Ossipee Watershed flow into the Saco River via the Ossipee River. The watershed's drainage area encompasses portions of 14 towns in New Hampshire (and is especially focused on 6 of them) and 1 town in Maine. It is bound by the mountains of the Sandwich Range to the northwest, the Ossipee Mountains to the south and the sandy pine barren lands of the Ossipee-Freedom-Effingham plains to the east. Elevations range from 375 feet at the Maine-New Hampshire border in Effingham to 4,060 feet on Mount Passaconaway in Waterville.

The Ossipee Watershed is comprised of 13 distinct drainage subsystems or **subwatersheds** (Figure 3). In Table 1, subwatersheds are matched with local political divisions. Detailed subwatershed boundaries and water resources maps can be viewed at the GMCG website, [www.gmcg.org](http://www.gmcg.org), or, using the on-line version of this manual posted at publication. (<http://www.gmcg.org/administration/pdf/OWCNaturalResourcePlanningGuide.pdf>), or by clicking the links in the table below.

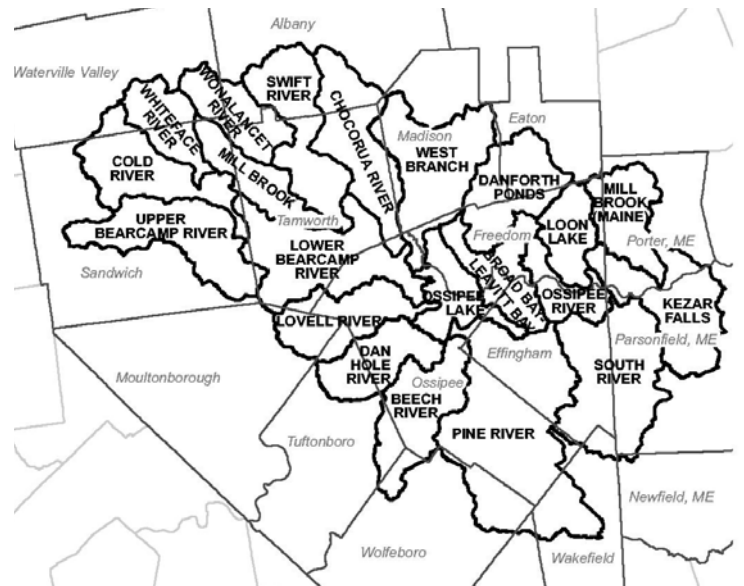

**Chapter V-A.1 Figure 3:  
Ossipee Watershed**  
*(map created by Katie Callahan)*

**Chapter V-A.1 Table 1: Subwatersheds of the Ossipee Watershed** (*SPNHF Water Resource Maps, gmcg.org*)

<b>Subwatershed</b>	<b>Principal Town(s)</b>	<b>Area(acres)</b>
Beech River Watershed	<a href="#">Effingham, Ossipee</a>	12041.7
Broad/Leavitt Bay Watershed	<a href="#">Effingham, Freedom, Ossipee</a>	9031.2
Chocorua River Watershed	<a href="#">Madison, Ossipee, Tamworth</a>	14193.8
Cold River Watershed	<a href="#">Sandwich</a>	12810.1
Danforth Ponds Watershed	Eaton, <a href="#">Freedom, Madison</a>	11903.7
Dan Hole Pond Watershed	<a href="#">Effingham, Ossipee</a>	9034.3
Kezar Falls Watershed	<a href="#">Freedom</a> , Porter (Me), Parsonsfield (Me)	14164.9
Loon Lake Watershed	<a href="#">Freedom</a>	6619.8
Lovell River Watershed	<a href="#">Effingham, Freedom, Ossipee</a>	10939.4
Lower Bearcamp River Watershed	<a href="#">Ossipee, Sandwich, Tamworth</a>	18354.8
Mill Brook Watershed	<a href="#">Sandwich, Tamworth</a>	7775.4
Mill Brook (Maine) Watershed	<a href="#">Freedom</a> , Porter (Me)	8941.8
Ossipee Lake Watershed	<a href="#">Effingham, Freedom, Ossipee</a>	7891.3
Ossipee River Watershed	<a href="#">Effingham, Freedom</a>	5615.8
Pine River Watershed	<a href="#">Effingham</a>	35247.8
South River Watershed	<a href="#">Effingham</a> , Parsonsfield (Me)	20063.4
Swift River Watershed	<a href="#">Sandwich, Tamworth</a>	13675.9
Upper Bearcamp River Watershed	<a href="#">Sandwich, Tamworth</a>	14762.8
West Branch Watershed	<a href="#">Freedom, Madison, Ossipee, Tamworth</a>	16650.8
Whiteface Watershed	<a href="#">Sandwich</a>	7432.2
Wonalancet River Watershed	<a href="#">Sandwich, Tamworth</a>	8342.1

### III. Current and Potential Impacts to Water Quality

It is important to remember that all watershed water resources are interconnected. However, discussing the watershed in its component parts helps to identify distinctive issues based on scale, location, and differing vulnerabilities. In Chapter V-A.2, issues related to ground water are discussed. Standing surface waters (i.e., lakes and ponds) are reviewed in Chapter V-A.3 and moving surface waters, i.e., rivers and streams) are covered in Chapter V-A.4.

## A. Water Quality Monitoring in the Watershed

Currently, conservation organizations, lake associations, individual towns, the Department of Environmental Services and University of New Hampshire have initiated water quality monitoring programs in the Ossipee Watershed, often accomplished with the help of many volunteers (Figure 4). Descriptions and summarized results of these programs will be included in Chapters V-A2-4.

Water quality data provides an understanding of how land use and underlying geology affects the water in our lakes, rivers, streams and groundwater supplies. Water quality monitoring of physical, chemical and biological parameters is required to create an understanding of '**base line**' (or background level) conditions of aquatic systems. Because we do not have sufficient historical data or long term background information to review, it is difficult to determine if current land use practices are negatively affecting water quality. Compiling water quality data will allow us to determine the effectiveness or harmfulness of specific land use practices in maintaining good water quality. These determinations can guide us in making informed decisions to protect the watershed's natural resources.



**Chapter V-A.1 Figure 4:** Volunteers often monitor local lakes, ponds, rivers and streams.

The most important step for future protection of the Ossipee Watershed's groundwater, lakes, ponds, rivers and streams is to continue with current monitoring programs. Continued monitoring will provide a working knowledge of the water and the land uses surrounding our surface waters. "To understand our ecosystems, there is a great need for regular, long-term biogeochemical data collected in the same fashion. Rivers are in a constant state of change. Without continued monitoring you have essentially taken a snap shot of one moment in time. While a photo can speak a thousand words, a living documentary can reveal volumes." (Dennis Finn, Saco River Corridor Commission)

## IV. Overall Recommendations for Watershed Protection:

- 1. Support Statewide and Especially Regional & Local Water Resource Planning:** While towns must encourage the state to continue its attempt to solidify a legislative program to effectively and proactively protect surface and ground waters (for examples, see Chapter V A.2 thru A.4), it is incumbent upon communities to formulate their own plans to protect local and watershed-wide water resources.
- 2. Continue & Expand On-going Monitoring Programs:** Forward thinking members of our community have established on-going monitoring programs to help us understand the Watershed's groundwater and surface water resources. The ability to detect and respond to threatening changes in these critical resources in the future depends upon sharing the responsibility for sustaining these watershed-wide efforts. Doing so will require both volunteer help and municipal funding to continue.
- 3. Develop and Support Watershed-wide Efforts to Protect Our Common Concerns:** The Ossipee Watershed Coalition has been formed to provide a forum for sharing watershed-wide concerns and planning for coordinated regional responses. To be effective, sustained, enthusiastic, and persuasive participation by municipal officials, business leaders, and other interested citizens will be needed to meet the OWC's goals on an ongoing basis.

## V. Helpful Links

DES Environmental Monitoring Database: <http://des.nh.gov/OneStop.htm>

DES Surface Water Quality Assessments [305(b)&303(d)]: [www.des.state.nh.us/wmb/swqa/303d](http://www.des.state.nh.us/wmb/swqa/303d)

NASA Global Change Master Directory: [www.gcmd.gsfc.nasa.gov](http://www.gcmd.gsfc.nasa.gov)

New England Interstate Water Pollution Control Commission: [www.neiwpcc.org/](http://www.neiwpcc.org/)

NH Rivers Council: [www.nhrivers.org](http://www.nhrivers.org)

River Network: [www.rivernetwork.org](http://www.rivernetwork.org)

Saco River Corridor Commission: [www.srcc-maine.org](http://www.srcc-maine.org)

Water Quality Standards: <http://des.nh.gov/wqs/>; [www.epa.gov/waterscience/standards/wqslibrary/nh/nh\\_1\\_chapter1700.pdf](http://www.epa.gov/waterscience/standards/wqslibrary/nh/nh_1_chapter1700.pdf)

## VI. References

Finn, Dennis. Saco River Corridor Commission website: [www.srcc.com](http://www.srcc.com).

Society for the Protection of New Hampshire Forests. *Research Highlights from the New Hampshire Water Supply Land Conservation Project*, 1998. Available from <http://www.spnhf.org/pdf/drinkingwater.pdf>.

# Ossipee Watershed Coalition Natural Resource Planning Guide Chapter V - A.2 Groundwater Resources

## I. Introduction to the Importance of the Aquifer

The majority of residents and businesses in the Ossipee Watershed derive their drinking water from subsurface groundwater, by tapping the Ossipee Aquifer (Figure 1), New Hampshire's largest and deepest stratified-drift aquifer. An *aquifer* is a subsurface layer of porous material (sand or gravel) or fractured bedrock that accumulates and retains water. A **stratified drift aquifer** consists of highly porous subsurface sand and gravel soil deposited by melting glaciers. Subsurface aquifers can serve as drinking water sources using wells, both private (individual home) and public (community-based) wells. However, water flowing through them can also naturally resurface to add to standing waters such as lakes or downstream rivers. In this way, the quantity and quality of waters in the Ossipee Aquifer and the surface waters (lakes, ponds and streams) of the Ossipee Watershed are interconnected. In New Hampshire, ground water provides an estimated 40% of the total flow in rivers, which in turn feed the state's lakes, reservoirs, and estuaries. Because groundwater reservoirs can be large yet flow slowly, introduced contaminants can spread widely and remain problematic for long periods of time.

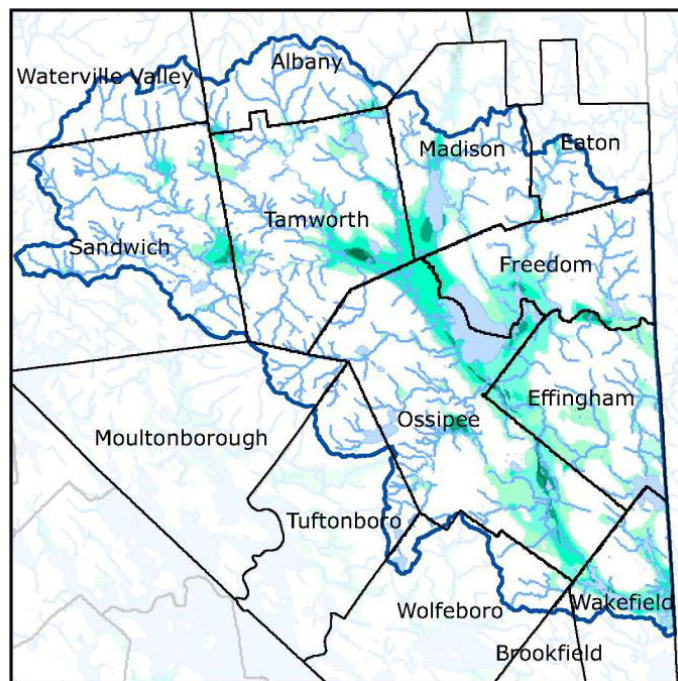

Chapter V-A.2 Figure 1: Ossipee Aquifer  
(map created by Katie Callahan)

## II. Description of the Resource

Stratified-drift aquifers cover 15% of the state and are referred to as **high yield aquifers** because they recharge rapidly. They are connected to water supply lands by highly permeable soils that readily absorb precipitation and allow it to percolate rapidly (sometimes at more than 8,000 ft<sup>2</sup> per day) down to the subsurface water table, filling the aquifer. **Water Supply Lands** or **aquifer recharge areas** are surface land areas that are connected with the groundwater by highly porous soil or rock layers (see aquifer recharge map, Chapter IV. Figure 15); they are classified as:

- **Primary recharge areas** occur where water infiltrates directly into the aquifer
- **Secondary recharge areas** are zones adjacent to the aquifer where surface and groundwater eventually recharge the aquifer
- **Tertiary recharge areas** supply water to streams that flow across the primary recharge area, and may or may not recharge the aquifer depending on water levels.

Undisturbed forest cover overlying recharge areas provides optimal conditions for encouraging the absorption of water. Maintaining such forest fabric which also intercepts household and commercial/industrial contaminants is especially important in the case of the highly vulnerable, rapid-percolation aquifers of the Ossipee Watershed. Current procedures for reclaiming pollution-contaminated soils by

"phytoremediation" (i.e., planting vegetation to uptake and sequester organic compounds (such as chlorinated hydrocarbons) or inorganic substances (such as heavy metals) are based on the inherent ability of all plants to absorb chemicals readily from their surroundings. The growth of a healthy cover of forest or riparian (stream- or lake-side) vegetation can prevent excess nutrients or pollutants from passing along to aquifers or surface water bodies.

**A. Aquifer Distribution:** Protecting water supply land is critical to protecting drinking water. Adequate protection depends on well capacity and the nature of the drinking water system it supplies (i.e., private vs. public, small vs. large). In Table 1, see the referenced acreage of water supply land and high yield aquifer for each town, as well as the percent of high yield aquifer protected as of 2004.

(in acres)	Water Supply Land	High Yield Aquifer <sup>1</sup> 11	Protected High Yield Aquifer (acres)	% Protected High Yield Aquifer
<b>Ossipee</b>	11,692	10,154.30	2,428.40	23.90%
<b>Tamworth</b>	6,451	5,162.30	1,029.10	19.90%
<b>Effingham</b>	5,488	3,756.50	1,132.10	30.10%
<b>Madison</b>	4,896	3,544.10	564	15.90%
<b>Freedom</b>	4,435	3,082.10	379.9	12.30%
<b>Sandwich</b>	1,534	1,303.10	24.2	1.90%
<b>Total</b>	<b>34,496</b>	<b>27,002.40</b>	<b>5,557.70</b>	<b>20.60%</b>

**Chapter A.2 Table 1: Distribution of Ground Water Resources in the Ossipee Watershed.** Table footnotes: from the Forest Society's *NH's Changing Landscape* base data through 2004. <sup>1</sup> 'High Yield Aquifer' represents acres of subsurface stratified-drift aquifer supporting maximum transmissivity (or fluid flow rates) in excess of 2,000 ft<sup>2</sup> per day. Conservation and Public lands data provided by GRANIT (October 2004) and updated by SPNHF. Data produced by USGS and distributed by NH Department of Environmental Services.

**B. Groundwater Monitoring:** Introductory information regarding Water Quality Monitoring in the Ossipee Watershed can be found in Chapter V-A.1. Ground water has been monitored for water levels in the past at various sites, and GMCG is currently working with New Hampshire Geological Survey to create a comprehensive well monitoring program. This program will involve tracking ground water quality and quantity over time and across the watershed every year. In addition, NH DES has approved funding for GMCG's Source Water Protection Project for the Ossipee Watershed -- a project for 2007 and 2008 that will address potential contamination source (PCS) identification, mitigation strategies and improved groundwater protection for watershed towns. Public education and outreach will be an essential element of this project. This project will encourage towns and public water suppliers to monitor PCSs with periodic Best Management Practices (BMPs), surveys (inspections), outreach and education.

### III. Current and Potential Threats to the Ossipee Aquifer

With the population of Carroll County expected to increase by 50% by 2020 (Office of State Planning, Forest Society, 2005), it is becoming imperative to plan and act now in order to protect water resources for the future. Increased population, residential and commercial development, the possibility of commercial extraction of ground water, and expanded recreational use of the area's water resources are all looming threats to the quality and sustainability of drinking water supplies. According to Sarah Pillsbury of the N.H. DES, the greatest threats to the state's water supplies include: development, the use of regulated substances (such as fertilizers and household chemicals), underground storage tanks, transportation corridors and roads, and commercial septic systems (Forest Notes, 2006).

**A. Water Quality:** There are natural and human influences on the quality of groundwater resources.

1) **Natural influences:** The quality of water in an aquifer depends on surrounding geologic factors, the chemistry of regional precipitation, and the influence of human activities in recharge areas. Geological features are a 'given' – fundamentally beyond our control. Low availability of limestone deposits throughout the granitic northeast provide poor buffering against acidic atmospheric components that drift from population and industrial concentrations to the west. Acidification of rainfall and resulting water sources is a continuing threat, as are metals and other air contaminants that influence the chemistry of regional precipitation.

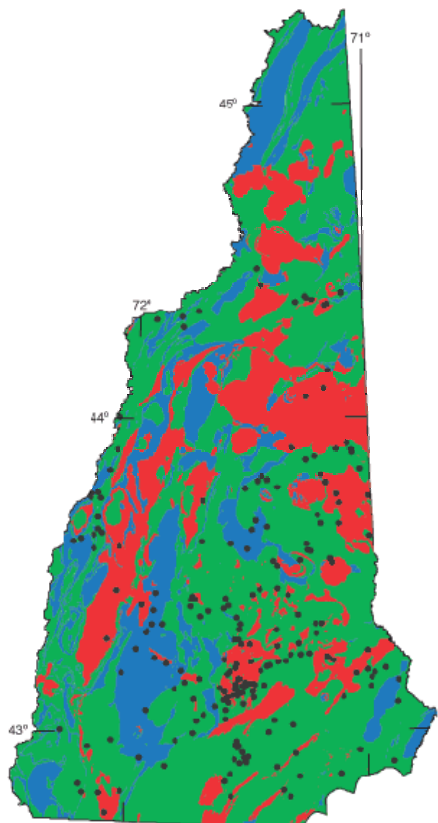

**Chapter V-A.2, Figure 2: Radon Concentrations in Ground Water.**

Location of domestic-bedrock-well sample sites for radon concentration in ground water and statistical distribution of concentrations in relation to radon-potential categories. Red indicates areas with high radon-potential, green – medium, blue – low. (Map created by USGS)

2) **Human Influences:** The human activities that must be addressed include those considered to be local **potential contamination sources (PCSs)** (Table 3), which can negatively impact water quality and public health. These are threats because they either involve the discharging of wastewater or the handling of substances that can cause contamination if they leach into the ground. In New Hampshire, 54% of known PCSs are located above stratified drift aquifers (Susca, 2006). Well over 150 PCSs are located within aquifer

Along with acid rain and metals, radon can also impact local drinking water supplies. Radon is a naturally occurring radioactive gas that emanates from rocks and soils. New Hampshire has some of the highest radon levels in the country, and areas of the Ossipee Watershed and Carroll County are particularly at risk (Figure 2).

Common contaminants in New Hampshire, both natural and human-related, are summarized in Table 2, along with recommended testing frequency for dug and bedrock wells. Laboratory testing is important since many contaminants often have no taste, odor, or color, and some contaminants have been linked to cancer and toxicity. Testing for bacteria and chemical contaminants is mandatory for public water supply sources. However, there is no state requirement to have private well water tested. As a result, a few towns, primarily in southern New Hampshire, have identified their own lists of required water quality test parameters for private wells.

Chapter V-A.2, Table 2: Recommended Private Well Testing

Recommended DES "Standard Analysis"	Testing Frequency			
	Bedrock	Dug	Regular*	if greater than 75%**
<b>Arsenic</b>	x	x	3-5 years	quarterly
<b>Bacteria</b>	x	x	annually	Immediately
<b>Chloride</b>	x	x	3-5 years	annually
<b>Copper (nonflushed)</b>	x	x	3-5 "	annually
<b>Fluoride</b>	x	x	3-5 "	annually
<b>Hardness</b>	x	x	3-5 "	annually
<b>Iron</b>	x	x	3-5 "	annually
<b>Lead (nonflushed)</b>	x	x	3-5 "	quarterly
<b>Manganese</b>	x	x	3-5 "	annually
<b>Nitrate /Nitrite</b>	x	x	3-5 "	1/month
<b>pH</b>	x	x	3-5 "	Not App.
<b>Sodium</b>	x	x	3-5 "	annually

\* Testing should continue until the average concentration is determined for naturally occurring contaminants.  
 \*\* Suggested follow up testing if the concentration of the contaminant is greater than 75 percent of the standard. (created by NH DES)



recharge areas for the more than 100 public water supply sources in the Ossipee Watershed (NH DES Drinking Water Source Assessment Report, 1999).

Chapter A.2, Table 3: Potential Contamination Sources (source NH DES)	
Above & Underground Storage Tanks	Snow Dumps
Auto Service & Repair Shops	Highways
Hazardous Waste Facilities	Septic Systems
Salvage Yards	Storm Drains or Basins
Cleaning Services	Salt Storage Facilities

Human-related contaminants include **volatile organic compounds (VOCs)** and **synthetics organic compounds (SOCs)**. There are approximately 60 organic contaminants in these two categories. Common VOCs include the gasoline additive MtBE and industrial solvents. MtBE contamination of ground water is a concern primarily in the population-dense southeastern New Hampshire, although the percentage of public wells with MTBE greater than 0.5 µg/L has risen statewide from 2000-2003 (Figure 4). SOC include pesticides and herbicides. Activities that would produce VOCs and SOC include heavy industrial or commercial

activity, past or present landfills, buried chemical or hydrocarbon storage tanks. Laboratory testing for these contaminants is available (Table 4), though expensive, and public wells may be required to periodically test for VOCs and SOC. Private well owners can decide whether or not VOC or SOC testing is warranted based on land uses around their well. The benefits of testing and preventing contamination in the first place, however, far outweigh the costs of remediation (Table 5).

**Chapter A.2, Figure 4: Public Wells & MtBE.** Percent of public water-supply wells with concentrations of MTBE greater than or equal to 0.5µg/L by county for 2000, 2001, and 2002 for reformulated gas (RFG) and non-RFG counties. (Map created by USGS)

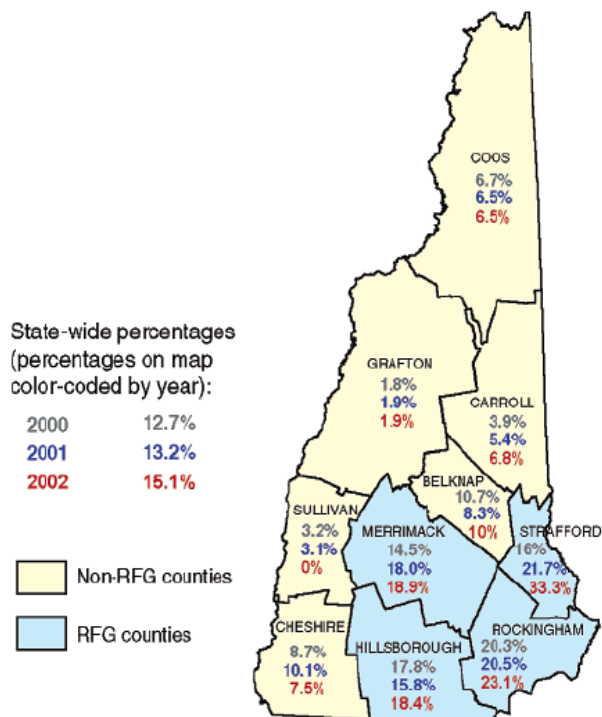

**Chapter V-A.2, Table 4: Recommended Additional Test Parameters for Private Wells**

	Bedrock	Dug	Regular	if greater than 75%
VOCs (Solvents and hydrocarbons)	x	x	5-10 "	See below
Radon (special bottle req.)	x	x	3-5 "	annually
Gross (screen) alpha	x		5-10 "	annually

Community	Contaminant	Total Cost
Sabbatus	salt	\$500,000
Norway	gasoline	\$600,000
Lisbon	solvents	\$865,000
Pittsfield	landfill leachate	\$1,500,000
Guilford/Sangerville	flame retardant	\$236,000
Sanford	DNAPLs	\$510,000

Source: Emery & Garrett, 1993

**Chapter V-A.2, Table 5: Clean up Costs for Municipal Systems from common contaminants.** (NH DES presentation, 2007)

Currently, many public water supply sources are at risk because they are not within protected conservation lands and lack sufficient wellhead protection or education and inspections programs (Table 6). A **wellhead protection area (WHPA)** refers to a circular area of land centered over a well, drawn at a radius related to the well's capacity (Figure 5). Figure 6 shows WHPAs within the Ossipee Watershed. Table 6 shows protected WHPAs within the six main Ossipee Watershed towns as compared to protected WHPAs within Carroll County and the state as a whole. The assumption that the WHPA is circular has to be made if resources are not available to do a rigorous aquifer analysis via pumping tests.

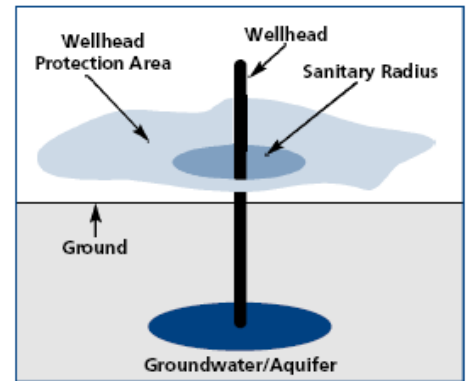

**Chapter V-A.2, Figure 5: Wellhead Protection Area (WHPA)** (created by NH DES)

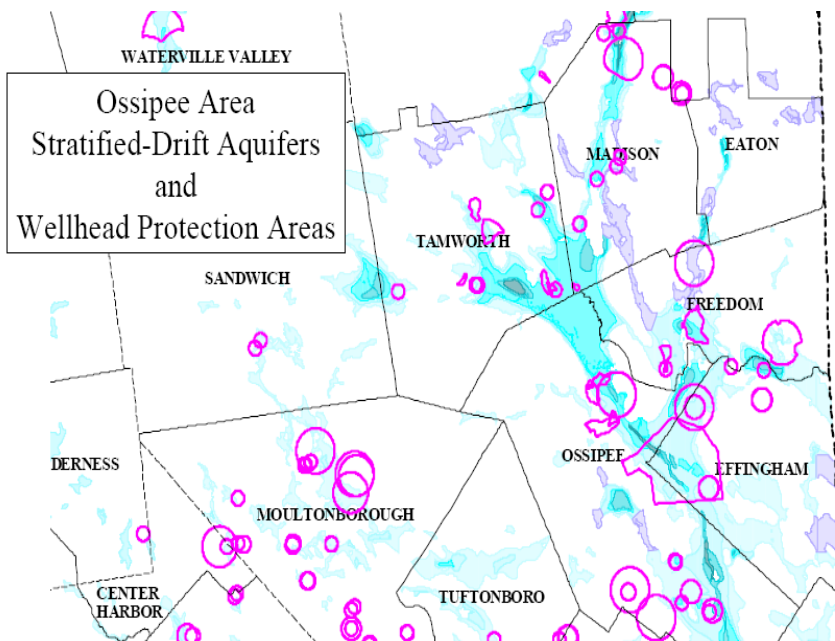

**Chapter V-A.2, Figure 6: WHPAs in the Ossipee Watershed** (map created by NH DES)

In a glacial outwash aquifer such as the Ossipee Aquifer, this assumption is probably close to representing true conditions in the aquifer and so, assuming that calculations in determining the radius of the protection zone are correct, then the WHPAs listed in Table 6 are probably close to accurate. It should also be remembered that these areas are predicated on a given discharge rate of the pumped well(s) and perhaps other variable which could change over time (Baldwin, 2007).

	Wellhead Protection Area (acres)	Area WHPA Protected (acres)	% Protected WHPA <sup>1</sup>	Coincident High Yld Aquifer <sup>2</sup> & WHPA	Protected Coincident Aquifer & WHPA	% Protected Aquifer & WHPA
Ossipee	5,104.50	1,543.10	30.20%	1,350.60	543.4	40.20%
Effingham	4,503.30	1,091.20	24.20%	2,609.00	893.2	34.20%
Freedom	2,552.30	24.6	1.00%	582	1.7	0.30%
Madison	1,984	31.2	1.60%	658.2	2	0.30%
Tamworth	1,838.30	163.6	8.90%	567.9	75.8	13.40%
Sandwich	218.6	4.9	2.30%	0	0	0
Carroll County	38,799.8	4,997.1	12.90%	9,024.9	2,031.6	22.5%
NH	317,592.3	34,076.3	10.7%	33,270.8	5,140.7	15.5%

**Chapter V-A.2, Table 6: Wellhead Protection Areas and Protected WHPA's and High Yield Aquifer in the Ossipee Watershed.** Footnotes: delineated by NH Department of Environmental Services. <sup>1</sup>'Protected WHPA' includes acres of wellhead protection areas that lie within protected conservation lands. <sup>2</sup>'Coincident Aquifer and WHPA' include acres where wellhead protection areas fall over high-yield aquifers - greatest potential for locating high-capacity wells.

**B. Water Quantity:** Sustainable use of groundwater resources requires the overall withdrawal rate from an aquifer to not exceed the rate at which it is recharged. Both natural processes and human activities can impact water levels. For example, in the Ossipee Aquifer, water use doubles in the summer months because of agricultural irrigation as well as lawn watering and seasonal tourism (Kernan, 2006).

The laws governing New Hampshire groundwater resources follow the principles of Eastern Water Law. Under Eastern Water Law, all water rights are equal and users may only use a 'reasonable' amount of water such that the ability to use water by others is not impaired. In 1998, a groundwater permitting program was enacted that allows DES to permit any new withdrawal projects that will exceed 40 gallons per minute (or 57,600 gallons daily). This permitting process insures that: (1) new withdrawal projects do not adversely affect existing users and (2) new projects use groundwater resources efficiently. Projects must be re-permitted every ten years. However, the permitting process has weaknesses. Applicants for large groundwater withdrawal permits can divide their project so that there are several small wells, none of which exceeds the 57,600 gallons daily threshold. Companies can also apply for wells under two different names, so that no single well triggers the threshold. Developments sometimes put in a central well that does not trigger the 57,600 threshold but also does not provide sufficient volume for the development. The central well is then supplemented with private wells, increasing the total withdrawal (Kernan, 2006).

**C. Large-Scale Groundwater Withdrawal:** Lack of understanding of the complexity of subsurface hydrology and its relation to specific surface water features in the region makes it difficult to predict the effects of substantial new groundwater withdrawal. Pumping large amounts of water to meet increasing demands on public water supplies and for commercial bottling operations can impact water levels. A large withdrawal project has the potential to dewater nearby wells; to reduce groundwater supply to some surface water bodies such as wetlands, streams, and ponds; and to cause changes in water quality. While some surface water bodies might be affected by a project, others might not. The impact on wetlands is especially difficult to measure because wetlands must be assessed for their functions and the value of those functions. Surface water bodies should be monitored annually to determine if changes in the ecosystem are due to groundwater withdrawal or other phenomena. Careful study by experts, including hydrogeologic modeling, is required to evaluate the regional impact of large-scale withdrawals.

## IV. Recommendations

**1. Implementation of Best Management Practices (BMPs):** State professionals recommend that towns use a multiple-level approach to address the challenge of source water protection (Table 7). Here are some questions community leaders, public water suppliers, businesses, and conservation groups can ask to help determine what source water protection measures may be needed. Addressing source water protection not only makes good economic sense, it also provides the potential for developing new wells in the aquifer in the future.

- n Where are your water supply lands?
- n How well protected are they?
- n Do you have local land use regulations in place to help protect these water sources?
- n What important natural resources are associated with your water supply lands?
- n Where are the contamination sites, roads and development in relation to your critical water supply lands?
- n Where will your community get its water in the future?
- n Will this land remain undeveloped and available to supply clean water when you need it?
- n Which landowners could you approach to discuss land conservation?
- n What sources of funding are available to help conserve these lands?

*(From the Society for the Protection of New Hampshire Forests for the New Hampshire Department of Environmental Services October, 1998.)*

<b>Chapter V-A.2, Table 7: Summary of Source Water Protection Measures</b> <i>(adapted from NH DES website)</i>	
<b>Protection Approach</b>	<b>Description</b>
Education	Education programs for business owners, school-aged children and the general public should always be a part of a local source protection program. Many materials are available for this purpose. Educating residents about water conservation can reduce the need for large groundwater withdrawals and protect future drinking water and surface water supplies.
Emergency Response Planning	All sources with roads or certain other land uses near surface waters are vulnerable to accidental spills (motor fuels, other regulated contaminants, sewage, manure, etc.). Water suppliers using these sources should conduct emergency response planning consisting of detailed inventories of land uses and contaminants that may be released, development of communications protocols to minimize response times, and preparations for spill response (containment, clean-up, intake/well shut-off, alternate sources). DES has conducted dye tracer studies to determine times of travel to the PWS intakes for large river sources; the results are available from DES.
Health Ordinance or Regulation	While land use boards (through zoning and site plan and subdivision review) address future threats, health ordinances and regulations can establish standards that address existing threats, as well as assuring ongoing compliance.
Household Hazardous Waste Collection	To prevent the improper disposal of hazardous wastes, many communities sponsor household hazardous waste collection days or collection centers. Matching grants are available from DES.

Inspection Programs	<p>Water suppliers and municipalities can conduct inspection or visitation programs to ensure compliance with Best Management Practices (BMPs) for the storage and handling of regulated substances. These programs can rely on voluntary participation of business owners, or they can be mandatory programs based on municipal health regulations. Municipalities may also have inspection programs related to underground storage tanks, forestry practices, gravel excavations, or the application of fertilizer, manure, sludge or septage. The N.H. Department of Agriculture, Markets, and Food can be called upon to investigate complaints and ensure compliance with BMPs for the handling and use of fertilizer, manure, compost, and pesticides. DES can be called upon for enforcement of certain BMPs.</p> <p>**Preventing contamination from PCSs can protect public health, maintain water quality and help towns avoid expensive clean-up costs. DES has approved funding for the GMCG's Source Water Protection Project for the Ossipee Watershed -- a project for 2007 and 2008 that will address potential contamination source (PCS) identification and mitigation strategies and improved groundwater protection for watershed towns. Public education and outreach will be an essential element of this project. This project will encourage towns and public water suppliers to monitor PCSs with periodic Best Management Practices (BMPs) surveys (inspections), outreach and education.</p>
Land Acquisition	<p>Provides absolute control of land usage. Currently loan and grant money and technical assistance from the federal and state government are available for land acquisition purposes. Water supply land conservation easements may also be used with less cost than outright purchase. Model easements were developed by the Society for Protection of New Hampshire Forests and are available through DES. Buffers may also be set aside by developers if the planning board knows protection needs.</p> <p>**A recent study by the Trust for Public Lands and the American Water Works Association demonstrated the economic benefits of conserving land to protect drinking water quality, showing that the more forest cover in a watershed, the lower the water treatment costs. In the study of 27 surface water supplies, it was found that for every 10% increase in forest cover, treatment and chemical costs decreased approximately 20% (<i>Forest Notes, 2006</i>).</p>
Subdivision and Site Plan Review	<p>Subdivision and site plan review provide opportunities to address water supply concerns at the initial stage of development. These regulations may also be modified to set design and/or performance standards for new developments.</p>
Water Quality Monitoring	<p>Monitoring is effective to identify areas needing additional investigation or management. Monitoring identifies the status of watershed water quality and may be used to evaluate trends or as a sentry or early warning system for contamination moving towards the source.</p>
Watershed Rules	<p>Water suppliers can petition DES to enact watershed regulations to prohibit certain incompatible land and water uses (e.g. swimming, boating) on or near the water supply source and its tributaries. The advantage of this approach is that its reach may extend to the entire watershed, regardless of municipal boundaries.</p>
Zoning	<p>Zoning regulations may be modified to prohibit or restrict new potential contamination sources from locating in a wellhead protection area (WHPA). This is important for preventing serious impacts to water quality from future development. This should be coupled with other measures if the protection area already contains grandfathered potential contamination sources. NH DES has identified 69 towns in the state with groundwater protection ordinances, most prohibiting certain land uses and underground storage tanks, and some are based on the model ordinance drafted by the NH DES. Since most large groundwater withdrawal projects receive zoning variances, stringently applied zoning laws can also effectively control large groundwater withdrawal projects. The NH Model Groundwater Protection Ordinance is another tool for Watershed towns to regulate land uses that may affect ground water. It has been designed for the protection of aquifers as well as other locally important groundwater, which may include wellhead protection areas and can be viewed at: <a href="https://www.des.state.nh.us/dwssp/model_groundwater.pdf">https://www.des.state.nh.us/dwssp/model_groundwater.pdf</a></p>

**2. Extend Critical Drinking Water Protection Areas:** Table 1 shows us that just over 20% of the land overlying the Watershed's critical, high-yield aquifers are currently protected. Expanding the 'safety net' of protected areas should be a high priority.

**3. Identify and Monitor Groundwater Threats:** Potential Contamination Sources (PCSs) for public and private groundwater supplies in each town need to be identified and monitored.

**4. Evaluate Potential Drinking Water Supply & Demand:** As questions arise about exporting quantities of drinking water from local supplies, careful modeling studies are needed to evaluate the potential impact of such activities on current and future drinking water supplies.

## **V. Model Ordinances for Groundwater Protection**

1. Careful management of our accessible aquifers filled with high quality drinking water is crucial to meeting current and future local needs. Clean, clear waters may also be attractive to corporate extractors engaged in bottling and sales of drinking water. Concerned by the potential impact of such large scale extractions, some New Hampshire towns are attempting to preempt commercial access to water supplies under their control by considering enacting ordinances that prevent such uses. While legal challenges to these actions may arise, enacting such ordinances does make clear a town's position regarding these issues before any actual instance occurs.

On March 18, 2006, Barnstead, NH was the first to enact an ordinance of this sort. Their statement includes a strong stand against conferring state or federal constitutional rights equivalent to those of citizens onto corporations. You may view their ordinance and a history of the process they used to enact it at: <http://www.newrules.org/gov/nhwater.html>

2. New Hampshire's DES has prepared a MODEL GROUNDWATER PROTECTION ORDINANCE (WD-06-41, February 1999, Revised June 2006: <http://www.des.nh.gov/dwspp/pdf/ModelOrdinance.pdf>) designed to assist municipalities in selecting a strategy for drinking water protection that is best suited to their town. DES points out that controlling land uses associated with groundwater sources proves most effective and can be done either through the adoption of zoning ordinances, by careful development-plan reviews, or by outright purchase or protection of critical areas. Faulty underground storage tanks along with spills of hazardous industrial chemicals are important sources of contamination and can be addressed by specific local regulations.

NH offers advice on including groundwater protection within town Master Plans and also on developing a more specific "water resources management and protection plan." The need to reduce non-point source pollution is underscored in the document "Best Management Practices to Control Nonpoint Source Pollution: A Guide for Citizens and Town Officials" (January, 2004) and The Center for Watershed Protection, ([www.cwp.org](http://www.cwp.org)) is an additional source of information for developing local zoning ordinances limiting non-point sources.

### **NH DES Model Groundwater Protection Ordinance:**

MODEL ORDINANCE      *(EXPLANATORY NOTES in italics)*

#### **I. AUTHORITY**

The [City or Town] of [Town Name] hereby adopts this ordinance pursuant to the authority granted under RSA 674:16, in particular RSA 674:16, II relative to innovative land use controls.

*(RSA 674 includes the zoning enabling law; RSA 675 governs enactment and adoption procedures; and RSA 676 governs administrative and enforcement procedures. RSA 674:21 provides examples of the innovative land use controls that municipalities may adopt under RSA 674:16, including performance standards and environmental characteristics zoning).*

## II. PURPOSE

The purpose of this ordinance is, in the interest of public health, safety, and general welfare, to preserve, maintain, and protect from contamination existing and potential groundwater supply areas *and to protect surface waters that are fed by groundwater*. The purpose is to be accomplished by regulating land uses which could contribute pollutants to designated wells and/or aquifers identified as being needed for present and/or future public water supply.

*(This section describes the purposes of this ordinance, which should be consistent with the purposes of an up-to-date, properly adopted master plan. The italicized text at left is optional; protection of drinking water sources is usually more compelling, if for no other reason than the fact that the contamination of drinking water sources has been far more common in New Hampshire than the contamination of surface waters by groundwater).*

## III. DEFINITIONS

A. Aquifer: a geologic formation composed of rock, sand, or gravel that contains significant amounts of potentially recoverable water.

*(This term is defined in order to clarify the purpose of the ordinance).*

B. Petroleum bulk plant or terminal: means that portion of the property where petroleum products are received by tank vessel, pipeline, tank car, or tank vehicle and are stored or blended in bulk for the purpose of distributing such liquids by tank vessel, pipeline tank car, tank vehicle, portable tank, or container.

C. Groundwater: subsurface water that occurs beneath the water table in soils and geologic formations.

*(This term is used in Prohibited Uses, Article IX, part G. From RSA 485-C, the Groundwater Protection Act).*

D. Gasoline station: means that portion of a property where petroleum products are received by tank vessel, pipeline, tank car, or tank vehicle and distributed for the purposes of retail sale of gasoline.

E. Impervious: not readily permitting the infiltration of water.

*(This term is used in Prohibited Uses, Article IX, part H. "Impervious" is used in Performance Standards Article VI, part D. It is defined to distinguish it from Impervious surface. What is considered impervious with respect to stormwater infiltration is not necessarily considered impervious with respect to containment of regulated substances).*

F. Impervious surface: a surface through which regulated substances cannot pass when spilled. Impervious surfaces include concrete unless unsealed cracks or holes are present. Asphalt; earthen, wooden, or gravel surfaces; or other surfaces which could react with or dissolve when in contact with the substances stored on them are not considered impervious surfaces.

*(From NH Code of Administrative Rules Env-Ws 421.03(c), Best Management Practices rules for groundwater protection, except that "substances" has been substituted for "contaminants").*

G. Junkyard: an establishment or place of business which is maintained, operated, or used for storing, keeping, buying, or selling junk, or for the maintenance or operation of an automotive recycling yard, and includes garbage dumps and sanitary landfills. The word does not include any motor vehicle dealers registered with the director of motor vehicles under RSA 261:104 and controlled under RSA 236:126.

*(From RSA 236:91 IV. Local authorities should encourage or require junkyards to be certified through the N.H. Green Yards Program and follow the program's Environment Guidance Manual. You can contact the N.H. Green Yards Coordinator at 271-2938. Pollution prevention measures can be found online at <http://www.des.nh.gov/sw/GreenYards>)*

H. Outdoor storage: storage of materials where they are not protected from the elements by a roof, walls, and a floor with an impervious surface.

*(This term is used in the Performance Standards (Article VI, part F and G and under Prohibited Uses*

(Article IX, part. C)).

I. Public water system: a system for the provision to the public of piped water for human consumption, if such system has at least 15 service connections or regularly serves an average of at least 25 individuals daily at least 60 days out of the year.

*(From RSA 485:1-a, XV. The definition used here is abbreviated because the only reference in this ordinance to a public water system is in the definition of wellhead protection area).*

J. Regulated substance: petroleum, petroleum products, and substances listed under 40 CFR 302, 7-1-05 edition, excluding the following substances: (1) ammonia, (2) sodium hypochlorite, (3) sodium hydroxide, (4) acetic acid, (5) sulfuric acid, (6) potassium hydroxide, (7) potassium permanganate, and (8) propane and other liquified fuels which exist as gases at normal atmospheric temperature and pressure.

*(From Env-Ws 421.03(f). The first seven chemicals are excluded from the statutory definition of regulated substance because they are used in the treatment of water supplies and are not considered to pose a significant risk to groundwater. Petroleum and petroleum products have been added with the exception of propane).*

K. Sanitary protective radius: The area around a public water supply well which must be maintained in its natural state as required by Env-Ws 378 or 379 (for community water systems); Env-Ws 372.12 and Env-Ws 372.13 (for other public water systems).

*(The sanitary protective radius ranges from 75 to 400 feet, depending on the amount of water withdrawn from the well. The minimum radius for a community well is 150 feet. The "natural state" requirement for new community wells prohibits all development within the sanitary radius of the well. Other noncommunity public water systems (i.e. hotels, campgrounds, convenience stores) have a less restrictive natural state requirement that allows a limited set of uses (i.e. parking lots, tennis courts) within the sanitary radii).*

L. Secondary containment: a structure such as a berm or dike with an impervious surface which is adequate to hold at least 110% of the volume of the largest regulated-substances container that will be stored there.

M. Snow dump: For the purposes of this ordinance, a location where snow, which is cleared from roadways and/or motor vehicle parking areas, is placed for disposal.

N. Stratified-drift aquifer: A geologic formation of predominantly well-sorted sediment deposited by or in bodies of glacial meltwater, including gravel, sand, silt, or clay, which contains sufficient saturated permeable material to yield significant quantities of water to wells.

O. Surface water: streams, lakes, ponds and tidal waters, including marshes, water-courses and other bodies of water, natural or artificial.

*(From Env-Ws 421.03(g). Prohibited under Article IX. From RSA 485-C:2, XIV. This definition is not needed if the ordinance is to be used only to protect wellhead protection areas. From RSA 485-A:2 XIV, Surface waters of the state).*

P. Wellhead protection area: The surface and subsurface area surrounding a water well or wellfield supplying a community public water system, through which contaminants are reasonably likely to move toward and reach such water well or wellfield.

*(From RSA 485-C:2, XVIII, except that the definition has been narrowed to include only wells for community (residential) public water systems and not other types of public water systems. This definition is not needed if the ordinance is to be used only to protect stratified-drift aquifers. Check with DES to see how the wellhead protection areas in your district have been delineated.*

*Phase II wellhead protection area delineations defined under Env-Ws 378 or 379 are considered to be a solid basis for land-use restrictions, but not all Phase I delineations are. Phase I delineations, also defined under the above rules, are based on available information, and if there was limited information available, then assumptions were made. If your wellhead protection areas are based*



*on Phase I delineations, consult with DES's Drinking Water Source Protection Program to see whether the delineations are appropriate to use as a basis for the zoning district boundary).*

#### IV. GROUNDWATER PROTECTION DISTRICT

The Groundwater Protection District is an overlay district which is superimposed over the existing underlying zoning and includes within its boundaries,

(1) all of the Wellhead Protection Areas for public water supply wells as defined under Article III, part (I) of this ordinance. The district is shown on the map entitled, Town of [Town Name] Groundwater Protection District, dated [Date Adopted ].

Or . . .

(2) the Stratified Drift Aquifer(s) shown on the map entitled, Town of [Town Name] Groundwater Protection District, dated [Date Adopted].

Or... a combination of the two.

*(Two options are presented in the model--one for wellhead protection areas and one for stratified-drift aquifers. A municipality may choose to protect one of these types of groundwater resource areas or both. If it chooses to protect both, the text in this section should be modified, as well as the title of the ordinance (i.e. Wellhead Protection or Aquifer Protection District). The municipality should develop and update a map to accompany the ordinance. Information on the extent of stratified-drift aquifers may be obtained from maps prepared by NH Geologic Survey or NH DES. Wellhead protection area (WHPA) maps are available from NH DES. (271-0688) When requesting a WHPA map from NH DES, please specify which types of WHPAs should be included (e.g. community systems only). See Appendix H, Defining and Revising Boundaries for Aquifer Protection Districts for guidance on drafting and revising the district boundary. The rationale or technical support for such a district should be incorporated into the municipal master plan prior to adoption of this ordinance).*

#### V. APPLICABILITY

This Ordinance applies to all uses in the Groundwater Protection District, except for those uses exempt under Article XII (Exemptions) of this Ordinance.

#### VI. PERFORMANCE STANDARDS

The following Performance Standards apply to all uses in the Groundwater Protection District unless exempt under Article XII:

*(The effectiveness of this model ordinance depends on the ability of the municipality to ensure initial and continuing compliance with these performance standards).*

A. For any use that will render impervious more than 15% or more than 2,500 square feet of any lot, whichever is greater, a stormwater management plan shall be prepared which the planning board determines is consistent with Stormwater Management and Erosion and Sediment Control Handbook for Urban and Developing Areas in New Hampshire, Rockingham County Conservation District, August 1992 and Best Management Practices for Urban Stormwater Runoff, NH Department of Environmental Services, January 1996.

*(Any lot could have up to 2,500 square feet of impervious area without requiring a stormwater management plan. For lots less than 0.38 acres the 2,500 square foot impervious area maximum applies while for lots larger greater than 0.38 acres, the 15% limit applies).*

B. Conditional uses, as defined under Article X shall develop stormwater management and pollution prevention plans and include information consistent with Stormwater Management For Industrial Activities: Developing Pollution Prevention Plans and Best Management Practices. (US EPA, 1992)

The plan shall demonstrate that the use will:

1) Minimize, through a source control plan that identifies pollution prevention measures, the release of regulated substances into stormwater;

2) Demonstrate that recharge to groundwater will not result in violation of Ambient Groundwater Quality Standards (Env-Ws 410.05) at the property boundary;

3) Stipulate that expansion or redevelopment activities shall require an amended stormwater plan and may not infiltrate stormwater through areas containing contaminated soils without completing a Phase I Assessment in conformance with ASTM E 1527-05, also referred to as All Appropriate Inquiry (AAI).  
*(Conditional uses, as listed in Article X, should infiltrate only clean or properly treated runoff and use pollution prevention measures (referred to as “source controls”) that prevent any regulated substances from mixing with clean runoff. Industrial or petroleum related areas or other sites that cannot prevent contamination of stormwater or effectively treat contaminants should be prohibited from infiltrating stormwater. EPA, through its NPDES General Permit for Storm Water Discharges Associated with Industrial Activity, requires the development and implementation of a pollution prevention plan.<sup>6</sup> A source control plan provides details concerning how operational or structural BMPs segregate clean from contaminated stormwater runoff (i.e. exposed to regulated substances). Source control plans may be part of existing Stormwater Pollution Prevention Plan as required by EPA’s NPDES. Ambient Groundwater Quality Standards are designed to ensure that groundwater is drinkable. Monitoring wells are the most effective way to monitor groundwater quality, spatially and temporally. The necessity and methods for using monitoring wells should be decided with input from a qualified professional geologist. Expansions or redevelopment of areas with preexisting soil contamination problems should be evaluated to determine whether changes to the surface or underlying soils will release existing contamination to groundwater. Environmental assessment standards and guidance for evaluating “brownfield” conditions can be obtained from the American Society of Testing and Materials (ASTM) or the US EPA. See EPA’s Brownfield’s website at <http://www.epa.gov/swerosps/bf/regneg.htm>.*

<sup>6</sup>Stormwater Management For Industrial Activities: Developing Pollution Prevention Plans and Best Management Practices. (US EPA, 1992) Online at [www.stormwaterauthority.org](http://www.stormwaterauthority.org) }

C. Animal manures, fertilizers, and compost must be stored in accordance with Manual of Best Management Practices for Agriculture in New Hampshire, NH Department of Agriculture, Markets, and Food, August 2005, and any subsequent revisions;

*(NH Department of Agriculture, Markets and Food may be consulted to help determine whether a particular facility is in compliance with the agriculture BMPs).*

D. All regulated substances stored in containers with a capacity of 5 gallons or more must be stored in product-tight containers on an impervious surface designed and maintained to prevent flow to exposed soils, floor drains, and outside drains;

E. Facilities where regulated substances are stored must be secured against unauthorized entry by means of a door and/or gate that is locked when authorized personnel are not present and must be inspected weekly by the facility owner;

F. Outdoor storage areas for regulated substances, associated material or waste must be protected from exposure to precipitation and must be located at least 50 feet from surface water or storm drains, at least 75 feet from private wells, and outside the sanitary protective radius of wells used by public water systems;

G. Secondary containment must be provided for outdoor storage of regulated substances if an aggregate of 275 gallons or more of regulated substances are stored outdoors on any particular property;

H. Containers in which regulated substances are stored must be clearly and visibly labeled and must be kept closed and sealed when material is not being transferred from one container to another;

I. Prior to any land disturbing activities, all inactive wells on the property, not in use or properly maintained at the time the plan is submitted, shall be considered abandoned and must be sealed in accordance with We 604 of the New Hampshire Water Well Board Rules.

*(Five performance standards (D through H) are based on Env-Ws 421, Best Management Practices for Groundwater Protections, which apply in all areas of the state. However, the state rules apply only to containers used at businesses considered Potential Contamination Sources that purchase, store or handle regulated substances in containers larger than 5 gallons. The advantages of including these*

standards here are:

- they are enforceable on the local level;
- owners are put on notice that the rules apply;
- they apply to a broader range of uses and activities;
- they apply to small containers as well as large;
- there is a process to ensure initial compliance (for uses that come under planning board review; and
- the planning board may require a performance bond to ensure compliance (for conditional uses).

The presence of a 5-gallon (or larger) container for regulated substances is what makes a facility subject to this ordinance, but performance standards E through H apply to all regulated substances containers at those facilities, even if they are smaller than 5 gallons.

The purpose of the New Hampshire Well Water Board's rule (We-604) concerning sealing abandoned wells is to prevent contaminants from groundwater through unsealed, abandoned wells.

Prior to development or redevelopment activities, inactive wells should be identified and determined to be in compliance with the NH Well Board's We 604 rule. For more information about Well Water Board rules contact 271-1974).

## VII. Spill Prevention, Control and Countermeasure (SPCC) Plan

Conditional uses, as described under Article X, part (A), using regulated substances shall submit a spill control and countermeasure (SPCC) plan to the [Fire Chief, Health officer or Emergency Management officer] who shall determine whether the plan will prevent, contain, and minimize releases from ordinary or catastrophic events such as spills, floods or fires that may cause large releases of regulated substances. It shall include:

- 1) A description of the physical layout and a facility diagram, including all surrounding surface waters and wellhead protection areas.
- 2) Contact list and phone numbers for the facility response coordinator, cleanup contractors, and all appropriate federal, state, and local agencies who must be contacted in case of a release to the environment.
- 3) A list of all regulated substances in use and locations of use and storage;
- 4) A prediction of the direction, rate of flow, and total quantity of regulated substance that could be released where experience indicates a potential for equipment failure.
- 5) A description of containment and/or diversionary structures or equipment to prevent regulated substances from infiltrating into the ground.

*(Article VII requires an SPCC plan for those conditional uses with more than 100 gallons or 800 lbs of a regulated substance on-site. This extends the state's current requirement for SPCC plans by applying it to all regulated substances and lowering the quantities required on-site to necessitate an SPCC plan. DES requires only facilities that store oil in an aggregate capacity of greater than 1,320 gallons or a completely buried storage capacity greater than 42,000 gallons to complete an SPCC plan. See Appendix B or view the US Gov. Printing Office website for a listing of regulated substances: [http://www.access.gpo.gov/nara/cfr/waisidx\\_00/40cfr302\\_00.html](http://www.access.gpo.gov/nara/cfr/waisidx_00/40cfr302_00.html)*

*Containment or diversionary structures should be located on plans and include: dikes, berms, retaining walls, curbing, culverts, gutters, or other drainage systems; weirs, booms, or other barriers; spill diversion ponds; retention ponds; catch basin covers, and sorbent materials.)*

## VIII. PERMITTED USES

All uses permitted by right or allowed by special exception in the underlying district are permitted in the Groundwater Protection District unless they are Prohibited Uses or Conditional Uses. All uses must comply with the Performance Standards unless specifically exempt under Article XII.

*(No Planning Board review is required unless such review is triggered by other provisions such as site plan or subdivision review).*

## IX. PROHIBITED USES

The following uses are prohibited in the Groundwater Protection District.

*(This model ordinance includes two regulatory approaches to protecting important groundwater: prohibiting high-risk land uses and ensuring that other land uses comply with performance standards. The short list of prohibited uses assumes that the municipality has the personnel resources to review development proposals, inspect construction activities, and ensure continuing post-construction compliance through periodic facility inspections. Without inspections to ensure continuing compliance with performance standards, this short list of prohibited uses does not provide a significant level of protection.*

- A. The development or operation of a hazardous waste disposal facility as defined under RSA 147-A;
- B. The development or operation of a solid waste landfill;
- C. The outdoor storage of road salt or other deicing chemicals in bulk;
- D. The development or operation of a junkyard;
- E. The development or operation of a snow dump;
- F. The development or operation of a wastewater or septage lagoon;
- G. The development or operation of a petroleum bulk plant or terminal;

H. The development or operation of gasoline stations.

*(Parts A-F of this section prohibit uses listed in RSA 485-C:12, that are prohibited in wellhead protection areas that have been reclassified to GAA. The last two uses, petroleum bulk plants/terminals and gas stations, have been added based upon DES's experience with groundwater contamination at gas stations. If the municipality does not plan to carry out an inspection program, the list of prohibited uses should be expanded. See Appendix C).*

## X. CONDITIONAL USES

The Planning Board may grant a Conditional Use Permit for a use which is otherwise permitted within the underlying district, if the permitted use is involved in one or more of the following:

A. Storage, handling, and use of regulated substances in quantities exceeding 100 gallons or 800 pounds dry weight at any one time, provided that an adequate spill prevention, control and countermeasure (SPCC) plan, in accordance with Article VII, is approved by the local Fire Department, Health officer or Emergency Management officer];

B. Any use that will render impervious more than 15% or 2,500 square feet of any lot, whichever is greater. In granting such approval the Planning Board must first determine that the proposed use is not a prohibited use and will be in compliance with the Performance Standards and Article VI as well as all applicable local, state and federal requirements. The Planning Board may, at its discretion, require a performance guarantee or bond, in an amount and with surety conditions satisfactory to the Board, to be posted to ensure completion of construction of any facilities required for compliance with the Performance Standards.

*(RSA 674:21(II) states that an innovative land use control ordinance may provide for the granting of conditional or special use permits by any of several different municipal authorities, including planning boards. While planning boards are typically more experienced at reviewing and determining appropriate conditions for various land uses, it may be desirable to substitute some other authority, such as the Zoning Board of Adjustment. Facilities that store and use regulated substances only in containers smaller than 5 gallons are exempt from the ordinance; other facilities are subject to inspections per Article XIV; and amounts exceeding 100 gallons/800 pounds require a conditional use permit.*

*The applicability of the performance guarantee or bond is limited to apply only to the construction of facilities, such as dikes, berms or stormwater treatment facilities, so that the bond can be released*

*once the facilities are constructed in compliance with the Performance Standards. In order to determine the amount of the guarantee or bond, the Planning Board generally will have to retain a consulting engineer to estimate the cost of building the required structures. The Planning Board will also need to consult with legal counsel to ensure that the town obtains the authority to enter the property in order to complete construction of the required structures if necessary. The Conditional Use Permit should reference approved plans so that it is clear what conditions are necessary for the Board to release the bond).*

## XI. EXISTING NONCONFORMING USES

Existing nonconforming uses may continue without expanding or changing to another nonconforming use, but must be in compliance with all applicable state and federal requirements, including Env-Ws 421, Best Management Practices Rules.

*(See the fact sheets in Appendix A for a summary of Best Management Practices Rules and the facilities to which they apply).*

## XII. EXEMPTIONS

The following uses are exempt from the specified provisions of this ordinance as long as they are in compliance with all applicable local, state, and federal requirements:

- A. Any private residence is exempt from all Performance Standards;
- B. Any business or facility where regulated substances are not stored in containers with a capacity of 5 gallons or more is exempt from Article VI, Performance Standards, sections E through H;
- C. Storage of heating fuels for on-site use or fuels for emergency electric generation, provided that storage tanks are indoors on a concrete floor or have corrosion control, leak detection, and secondary containment in place, is exempt from Performance Standard E;
- D. Storage of motor fuel in tanks attached to vehicles and fitted with permanent fuel lines to enable the fuel to be used by that vehicle is exempt from Performance Standards E through H;
- E. Storage and use of office supplies is exempt from Performance Standards E through H;
- F. Temporary storage of construction materials on a site where they are to be used is exempt from Performance Standards E through H;
- G. The sale, transportation, and use of pesticides as defined in RSA 430:29 XXVI are exempt from all provisions of this ordinance;
- H. Household hazardous waste collection projects regulated under NH Code of Administrative Rules Env-Wm 401.03(b)(1) and 501.01(b) are exempt from Performance Standards E through H;
- I. Underground storage tank systems and aboveground storage tank systems that are in compliance with applicable state rules are exempt from inspections under Article XIV of this ordinance.  
*(Residences and exempt businesses may still pose a risk of groundwater contamination from relatively small releases of regulated substances. These properties should be addressed by a public education program that includes periodic distribution of educational fliers (see example in Appendix E). For more information, see the introduction. Note that propane and liquefied gas fuels are not regulated under this ordinance; they are excluded from the definition of "Regulated Substance" because they do not pose a groundwater contamination hazard by virtue of their volatility. The municipality may wish to define temporary in terms of a certain number of months. RSA 430:49 prohibits local governments from regulating the registration, sale, transportation, or use of pesticides. To determine whether a storage tank system is in compliance with state rules, the municipality may contact NH DES at 271-3644. See the UST and AST fact sheets in Appendix A. The presence of a UST/AST system in compliance does not exempt the rest of the business or facility from inspections).*

### XIII. RELATIONSHIP BETWEEN STATE AND LOCAL REQUIREMENTS

Where both the State and the municipality have existing requirements the more stringent shall govern. *(Articles XIII, XV, and XVI are usually included within an existing ordinance and may not be necessary to be incorporated if this ordinance is adopted as an amendment. Enforcement procedures, penalties and violations should conform to existing municipal requirements. However, including the reference to inspections, would serve to put business owners on notice that inspections will be conducted).*

### XIV. MAINTENANCE AND INSPECTION

A. For uses requiring planning board approval for any reason, a narrative description of maintenance requirements for structures required to comply with Performance Standards shall be recorded so as to run with the land on which such structures are located, at the Registry of Deeds for [name of county] County. The description so prepared shall comply with the requirements of RSA 478:4-a.

B. Inspections may be required to verify compliance with Performance Standards. Such inspections shall be performed by the [designated agent] at reasonable times with prior notice to the landowner.

C. All properties within the Groundwater Protection District known to the [designated agent] as using or storing regulated substances in containers with a capacity of 5 gallons or more, except for facilities where all regulated substances storage is exempt from this ordinance under Article XII, shall be subject to inspections under this Article.

D. The [governing body] may require a fee for compliance inspections. The fee shall be paid by the property owner. A fee schedule shall be established by the [governing body] as provided for in RSA 41-9:a.

*(The provision for recording maintenance requirements on the deed serves to put future property owners on notice that they are subject to these requirements. It applies to any structure associated with any facility that comes under planning board review, not only those that require a conditional use permit under this ordinance. In order to achieve the goals of this ordinance, inspections should be performed at least once every three years. The municipality may wish to perform inspections in the entire groundwater protection district or only in areas considered most sensitive, most vulnerable, or most valuable. The term "designated agent" should be replaced with the appropriate person's title, such as Code Enforcement Officer, if such a position exists. If not, the governing body may wish to designate some other town official and include a definition of the term "designated agent." (The person designated by the [governing body] to carry out its inspection and enforcement role with respect to this ordinance.)*

*The term "governing body" should be replaced with the name of the governing body, e.g. Selectmen, Town Council).*

### XV. ENFORCEMENT PROCEDURES AND PENALTIES

Any violation of the requirements of this ordinance shall be subject to the enforcement procedures and penalties detailed in RSA 676.

### XVI. SAVING CLAUSE

If any provision of this ordinance is found to be unenforceable, such provision shall be considered separable and shall not be construed to invalidate the remainder of the ordinance.

### XVII. EFFECTIVE DATE

This ordinance shall be effective upon adoption by the municipal governing body.

## VII. Model Ordinance References

Ayotte, Joseph, Argue, Denise, and McGarry, Fredick. *Methyl tert-Butyl Ether Occurrence and Related Factors in Public and Private Wells in Southeast New Hampshire*. U.S. Geological Survey and State of New Hampshire, Department of Environmental Services, Waste Management Division, 2005.

Baldwin, Dwight. E-mail to Blair Folts. March, 2007.  
Forest Notes, 2006  
Kernen, Brandon. "New Hampshire Groundwater Issues" *Groundwater Conference*, April 2006.  
Moore, Richard. *Quality of Water in the Fractured-Bedrock Aquifer of New Hampshire*. U.S. Geological Survey, 2004.  
New Hampshire Department of Environmental Services. *Drinking Water Source Assessment Report*, 1999.  
New Hampshire Office of State Planning, Society for the Protection of New Hampshire Forests and The Nature Conservancy. *New Hampshire's Changing Landscape*, 2005. Available from <http://www.spnhf.org/research/papers/nhcl2005es.pdf>.  
Society for the Protection of New Hampshire Forests. *Research Highlights from the New Hampshire Water Supply Land Conservation Project*, 1998. Available from <http://www.spnhf.org/pdf/drinkingwater.pdf>.  
Susca, Paul. "And Now for the Good News!" *Groundwater Conference*, April 2006.  
Susca, Paul. "Local Source Water Protection Options and Private Wells" *Drinking Water Protection Conference*, April 2007.

## VIII. Helpful Links

American Groundwater Trust: [www.agwt.org](http://www.agwt.org)  
EPA Illegal Dumping Prevention Guidebook: [http://www.epa.gov/reg5rcra/wptdiv/illegal\\_dumping/downloads/il-dmpng.pdf](http://www.epa.gov/reg5rcra/wptdiv/illegal_dumping/downloads/il-dmpng.pdf)  
Groundwater Protection Council: [www.gwpc.org](http://www.gwpc.org)  
Groundwater Fact Sheet & Diagram: [http://www.usawaterquality.org/newengland/Focus\\_Areas/well/extension/EPA.jpg](http://www.usawaterquality.org/newengland/Focus_Areas/well/extension/EPA.jpg)  
Groundwater Reclassification: <http://www.des.state.nh.us/rules/env-dw901.pdf>  
Lists of PCSs & Public Water Suppliers by Town: <http://www2.des.state.nh.us/OneStop/>  
Model Conservation Easements for the protection of drinking water supplies: <http://www.spnhf.org/pdf/watersupply.pdf>  
NH DES Lab: <http://www.des.state.nh.us/lab/>  
NH DES Private Well Testing Information: [http://www.des.state.nh.us/well\\_testing.htm](http://www.des.state.nh.us/well_testing.htm)  
NH Department of Environmental Services Source Water Protection Program: [www.des.state.nh.us/dwssp/](http://www.des.state.nh.us/dwssp/)  
NH DES Radon Program: [www.des.nh.gov/ARD/EHP/Radon](http://www.des.nh.gov/ARD/EHP/Radon) (603) 271-1370  
Private Well Testing Pamphlet: <http://www.epa.gov/NE/eco/drinkwater/pdfs/privwellfinal.pdf>  
Public Water Supply Grants: <http://www.des.state.nh.us/rules/env-ws393.pdf>  
Radon Frequently Asked Questions: <http://www.des.state.nh.us/ARD/EHP/Radon/FAQs.asp>  
US EPA—Groundwater & Drinking Water: [www.epa.gov/ogwdw/](http://www.epa.gov/ogwdw/)  
US Geological Survey: [www.usgs.gov/](http://www.usgs.gov/)  
Water Conservation: <http://www.des.state.nh.us/rules/envws390.pdf>  
Water Supply Land Grant Program: <http://www.des.state.nh.us/rules/env-ws394.pdf>

### **New Hampshire Department of Environmental Services (NH DES) On-Line Resources.**

The New Hampshire Department of Environmental Services website (<http://www.des.state.nh.us/>) offers easily accessible information regarding responsibilities and opportunities for state, municipal, and individuals to address water resource issues. Here are brief summaries of just some of these links that relate to Groundwater/Drinking Water issues.

#### DRINKING WATER AND GROUNDWATER QUALITY:

1. Drinking Water and Groundwater Bureau (DWGB) (formerly the Water Supply Engineering Bureau) provides regulatory and non-regulatory tools to protect groundwater and sources of public drinking water. At this site, information provided includes: managing groundwater protection areas using Best Management Practices, Local Source Water Protection Grants, large groundwater withdrawals, bottled water sources, groundwater discharges, and more. Visit: <http://www.des.state.nh.us/DWSPP/>

2. Drinking Water Source Protection Program describes specific tools that towns can use to protect groundwater and public water supply wells, including: zoning laws and land use controls, reviewing new development projects, site plan review, subdivision regulations, stormwater regulations, health regulations and ordinances, gravel excavation regulations, septic system ordinances, underground storage tank regulations, and regulations for management of fertilizer and wastewater residuals.

They make available guidance documents such as: *Managing Stormwater as a Valuable Resource*, *Model Groundwater Protection Ordinance*, *Model Health Ordinance*. Visit: <http://www.des.state.nh.us/DWSPP/ordinanc.htm>

3. National Pollutant Discharge Elimination System – Federal Storm Water Program (Phase II) addresses runoff as the top category of nonpoint source pollution in New Hampshire. This site includes information on: New Hampshire Nonpoint Source Management Plan, Community car washes and water quality, the Federal & New England storm water programs, municipal separate storm sewer system permits, runoff control at construction facilities, and more. Visit: <http://www.des.state.nh.us/StormWater/>

4. Wastewater Engineering Bureau coordinates with the US EPA to control permits and compliance related to municipal and industrial wastewater plants. Information available here addresses both 'individual' and 'general' National Pollutant Discharge Elimination System (NPDES) permits. NPDES permits in New Hampshire are primarily issued to municipal and industrial wastewater treatment plants. There are also three general NPDES permits issued to implement the [Federal Storm Water Program](#). The municipal and industrial wastewater permits include **individual** NPDES permits that are issued to cover discharges from a single facility and general NPDES permits that are issued to cover groups of similar discharges. At this site you will find information regarding: Design Reviews, Engineer Prequalification, Grants & Loans, Permits & Compliance, Wastewater Operations. Visit: [http://www.des.state.nh.us/WWE/permits\\_compliance.htm](http://www.des.state.nh.us/WWE/permits_compliance.htm)

5. Water Well Board is designed to protect and improve the general health and to protect the groundwater resources of the state; by licensing well and pump contractors; by providing well construction records; and by adopting and enforcing standards for the construction of wells and the installation of pumps. The site lists municipal requirements for private well siting and other related information of use to homeowners, contractors, and municipal officials. Visit: <http://www.des.state.nh.us/WWB/index.asp>



**Ossipee Watershed Coalition  
Natural Resource Planning Guide  
Chapter V - A.3 Surface Water Resources: Lakes & Ponds**

**I. Introduction to the Importance of the Watershed's Lakes & Ponds**

In addition to Ossipee Lake (~4,000 acres) and Silver Lake (995 acres), 80 lakes and ponds are included within the Ossipee watershed (for a combined acreage of 4,995, representing 2% of the watershed. Tables 1 and 2 note the distribution of surface waters within the Watershed and the locations of 48 named standing water bodies. Surface waters, including adjacent **riparian areas** (i.e., bank region surrounding or lining a water body) and associated wetlands, are some of the region's most productive and diverse ecological systems, serving as critical feeding, spawning and brood rearing habitat for many wildlife species.

Lakes large and small are major economic contributors to Watershed towns. According to a 2003 NH Lake Alliance (NHLA) report, recreational use of NH's freshwaters generates up to \$1.52 billion annually while waterfront property owners contribute upwards of another \$247 million in property tax revenues. These economic benefits depend on high water quality in the Watershed's lakes and ponds. As primary destinations for vacationers, boaters and wildlife enthusiasts, standing water bodies face developmental pressure and environmental stress. To cite one example, even a three foot loss in transparency of lake water due to excessive plankton productivity or runoff and siltation can lead to a decrease in individual shoreline property values by as much as \$5,900 (R. Craycraft, 2006). Many other benefits derived from these water resources are more difficult to quantify but are no less important to the region.

**II. Description of the Resource**

The New Hampshire Department of Environmental Services (NH DES) provides a variety of valuable resources to help municipalities and citizens understand and manage issues related to lakes and ponds. Several can be found in Helpful Hints below.

**Chapter V-A.3 Table 1: Distribution of Standing Water Sources (surface waters, wetlands, etc.) within the Watershed. (Data reproduced from: New Hampshire's Changing Landscape..1999)**

	<b>Surface Waters (acres)</b>	<b>Shoreline-Great Ponds (&gt; 10 acres)</b>	<b>EPA High Value wetlands (acres)</b>
<b>Ossipee</b>	2,905	23.66	901
<b>Freedom</b>	2,082	22.52	0
<b>Sandwich</b>	1,946	29.95	185
<b>Madison</b>	1,473	18.96	113
<b>Effingham</b>	678	3.16	1044
<b>Tamworth</b>	541	10.71	85

**Chapter V-A.3 Table 2: Named Lakes & Ponds within the Ossipee Watershed**

<b>Town</b>	<b>Named Lakes &amp; Ponds</b>
Eaton	Hatch Pond, Long Pond, Purity Lake (partial)
Effingham	Berry Bay (partial), Chalk Pond, Hutchins Pond, Leavitt Bay (partial), Province Lake (partial),
Freedom	Danforth Ponds, Duck Pond, Huckins Pond, Loon Lake (to the Ossipee River), Lake Ossipee (partial), Shaw Pond, Trout Pond

Madison	Blue Pond, Cooks Pond, Cranberry Bog, Davis Pond, Drew Pond, Durgin Pond, Lily Pond, Loud Pond, Mack Pond, Maily Pond, Moores Pond (partial), Purity Pond (partial), Silver Lake, Whitton Pond (partial)
Ossipee	Archers Pond, Bean Pond, Black Pond, Conner Pond, Dan Hole Pond (partial), Duncan Lake, Garland Pond, Heath Pond, Lily Pond, Little Dan Hole Pond, Lost Pond, Moody Pond, Lake Ossipee (partial), Pine River Pond, Snake Pond, Upper & Lower Beech Ponds, White Pond
Sandwich	Bear Camp Pond, Beaver Pond (partial), Miles Pond
Tamworth	Beaver Pond (partial), Chocorua Lake, Great Hill Pond, Jackson Pond, James Pond, Little Lake, Lonely Lake, Moores Pond (partial), White Lake
Tuftonboro	Dan Hole Pond (partial)
Waterville Valley	Flat Mountain Pond

**Bottom-contour maps are available for several watershed lakes and ponds:**

- Berry Bay: [www.wildlife.state.nh.us/Fishing/bathy\\_maps/berrybay\\_freedom.pdf](http://www.wildlife.state.nh.us/Fishing/bathy_maps/berrybay_freedom.pdf)
- Broad Bay: [www.wildlife.state.nh.us/Fishing/bathy\\_maps/broadbay\\_ossipee.pdf](http://www.wildlife.state.nh.us/Fishing/bathy_maps/broadbay_ossipee.pdf)
- Connor Pond: [www.wildlife.state.nh.us/Fishing/bathy\\_maps/conner\\_ossipee.pdf](http://www.wildlife.state.nh.us/Fishing/bathy_maps/conner_ossipee.pdf)
- Danforth Ponds: [www.wildlife.state.nh.us/Fishing/bathy\\_maps/danforth\\_freedom.pdf](http://www.wildlife.state.nh.us/Fishing/bathy_maps/danforth_freedom.pdf)
- Lake Ossipee: [www.des.state.nh.us/WMB/vlap/2005/bathymetric/Ossipee\\_Lake\\_Ossipee\\_bathmap.pdf](http://www.des.state.nh.us/WMB/vlap/2005/bathymetric/Ossipee_Lake_Ossipee_bathmap.pdf)
- Leavitt Bay: [www.wildlife.state.nh.us/Fishing/bathy\\_maps/leavittbay\\_ossipee.pdf](http://www.wildlife.state.nh.us/Fishing/bathy_maps/leavittbay_ossipee.pdf)
- Lower Beech Pond: [www.wildlife.state.nh.us/Fishing/bathy\\_maps/beechnow\\_tuftonboro.pdf](http://www.wildlife.state.nh.us/Fishing/bathy_maps/beechnow_tuftonboro.pdf)
- Purity Lake: [www.wildlife.state.nh.us/Fishing/bathy\\_maps/purity\\_eaton.pdf](http://www.wildlife.state.nh.us/Fishing/bathy_maps/purity_eaton.pdf)
- White Pond: [www.wildlife.state.nh.us/Fishing/bathy\\_maps/white\\_ossipee.pdf](http://www.wildlife.state.nh.us/Fishing/bathy_maps/white_ossipee.pdf)
- Silver Lake: [www.silverlakemadison.com/pdf/SilverLakeDraft.pdf](http://www.silverlakemadison.com/pdf/SilverLakeDraft.pdf)
- All other lakes and ponds in NH: [www.wildlife.state.nh.us/Fishing/bathy\\_maps.htm](http://www.wildlife.state.nh.us/Fishing/bathy_maps.htm)

**A. Ossipee Lake System**

In many ways, the Ossipee Lake System is the visible focus of the Ossipee Watershed. Comprised of approximately 4,000 acres of water, the lake consists of a main body of water known as Ossipee Lake and four large connecting bodies of water (Figure 1). Water flows from Silver Lake, Bearcamp Pond and Dan Hole Pond to Ossipee Lake via the West Branch, Bearcamp and Pine Rivers, then into Broad Bay; from Broad Bay to Leavitt Bay, from Leavitt Bay to Berry Bay, and from Berry Bay to the Ossipee River. Table 3 below identifies these waterbodies and provides characteristics of each.

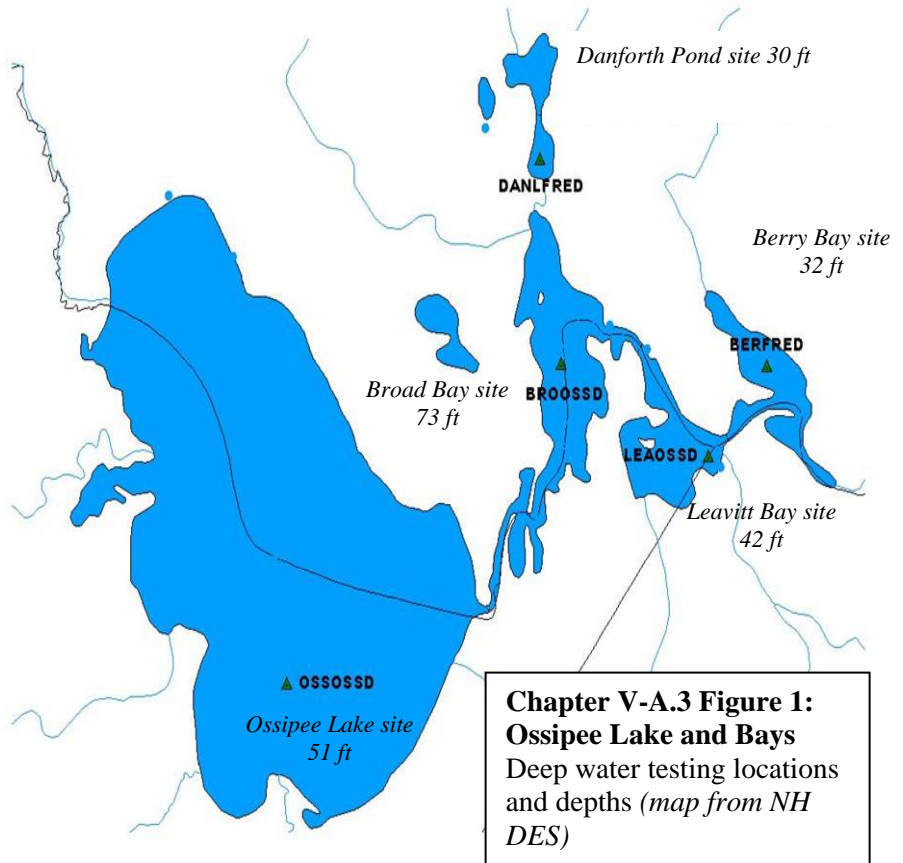

In 1995, the Environmental Protection Agency (EPA) listed **Ossipee Lake as one of the top five areas in New Hampshire to protect**. Using a standard for classifying surface waters of the state (pursuant to RSA 485-A:8,I-III), all Ossipee Lake System waterbodies are considered “**Class B Waters.**” Class B is the second highest quality, considered acceptable for fishing, swimming and other recreational purposes and, after adequate treatment, for use as drinking water. Ossipee Lake is also host to the Ossipee Lake Natural Area (OLNA), land owned by NH Dept. of Resources and Development. The OLNA consists of nearly two miles of uninterrupted shoreland along the south side of the lake and is home to unique pondshore communities.

The second largest lake in the Ossipee Watershed is the 995 acre Silver Lake in Madison. It measures 2.36 miles in length and averages 0.5 miles in width – 1 mile at its maximum. This comparatively deep lake includes 4 islands and is fed by 3 major inlets: Deer River, Cooks Brook, and Forrest Creek. Its dammed outlet feeds the West Branch River that eventually empties into Ossipee Lake.

**Chapter V-A.3 Table 3: Major Waterbodies Ossipee Watershed**

Lake	Town	Max depth (ft)	Volume (m3)	Area (acres)	Watershed (acres)	Flush Rate (times/yr) <sup>1</sup>
<b>Broad Bay</b>	Ossipee	73	15,573,500	463	224,436	34.1
<b>Leavitt Bay</b>	Ossipee	42	2,429,000	176	227,361	221.3
<b>Berry Bay</b>	Freedom	38	2,147,000	145	230,331	254
<b>Danforth Pond Lower</b>	Freedom	55	918,500	31	11,776	31.6
<b>Lake Ossipee</b>	Ossipee	60	108,421,500	3,091	209,599	4.6
<b>Total Ossipee Lake System</b>	Ossipee Freedom	73	12,989,500	3,909	903,505	
<b>Silver Lake</b>	Madison	164	57,503,000	995	14,912	.6
<b>Bearcamp Pond</b>	Sandwich	30	1,769,500	166	7,680	8.5

<sup>1</sup>The **flush rate** indicates how many times per year the volume of the water body would be replaced by the total volume of moving waters entering the body. *Source: NH DES VLAP & Bob Craycraft, UNH Lakes Lay Monitoring Program.*

**B. Lake Monitoring:** Please refer to introductory information regarding Water Quality Monitoring in the Ossipee Watershed in Chapter V-A.1. The **Ossipee Lake System** has been tested since 1990 by the NH Lakes Lay Monitoring Program and NH DES Volunteer Lakes Assessment Program (VLAP), with assistance from local volunteers, the Green Mountain Conservation Group (GMCG) and Ossipee Lake Alliance (OLA). Deep spots in each of the five main waterbodies are tested each summer for biological, chemical and physical water quality parameters. Sampling of the Ossipee Lake System thus far has shown good water quality when compared with other waterbodies in the state, however, some trends are apparent from the data that indicate human impact. Figure 2 shows one example of how a decreasing trend in transparency is apparent from the data collected at Broad Bay. Continued monitoring and statistical analysis of the data will determine whether or not water quality has changed since testing began. For in depth coverage of Ossipee Lake water quality monitoring results see the links below to past reports.

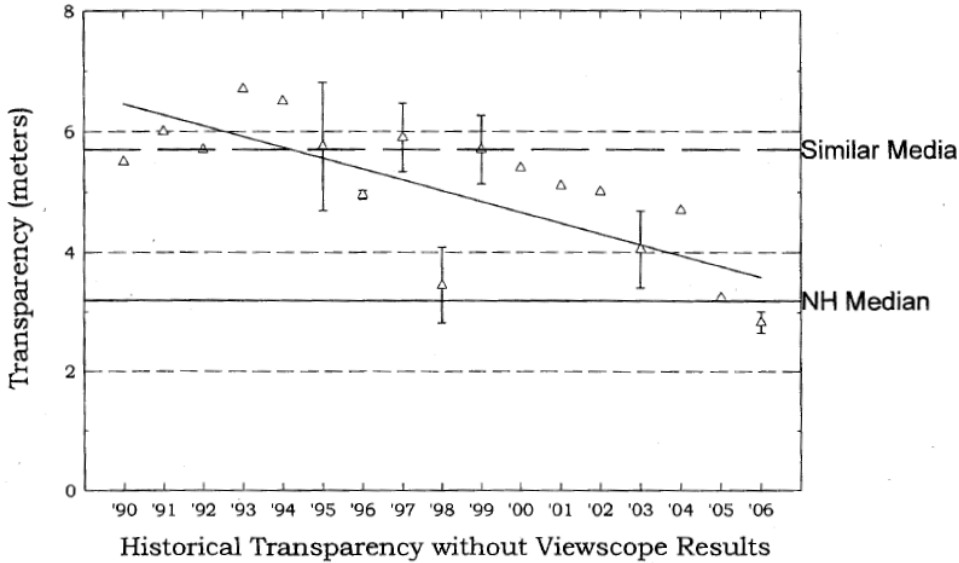

**Chapter V-A.3 Figure 2: Water transparency or clarity at Broad Bay.**  
 Annual reports contain data and graphs that show apparent trends in water quality. This graph shows how lake transparency in Broad Bay appears to be worsening over time.

The **Silver Lake** water quality monitoring program began in 1983. The program was designed to quickly identify water quality changes and problems through frequent measurement. Samples and values are collected by volunteers at six stations strategically located around Silver Lake each week during the warmer months. Additionally, a team from the fresh water biology group at the University of New Hampshire visits Silver Lake annually for more extensive testing. Data concerning water temperature, water clarity, lake stratification, chlorophyll content, phosphorus level and acidity (pH) are collected and analyzed. These data form the basis of an extensive annual report and comparative evaluation (copies of annual reports available at the Madison Public Library). Silver Lake averages are compared to the State of New Hampshire standards for 'pristine' waters in Table 4 below.

**Chapter V-A.3 Table 4: Silver Lake Water Quality** (*Silver Lake Association of Madison, 2007*)

Parameter	State Standard	Average for Silver Lake
Water Clarity	>4.0 meters	5.9 meters
Chlorophyll a	<3.0 ppb	1.4 ppb
Phosphorus	<15 ppb	6.0 ppb

**Water Quality Reports & DES VLAP information for the Ossipee Lake System:**

- DES VLAP [2003 Report: www.des.state.nh.us/wmb/vlap/2003/documents/OssipeeLakeSystem.pdf](http://www.des.state.nh.us/wmb/vlap/2003/documents/OssipeeLakeSystem.pdf)
- DES VLAP [2004 Report: www.des.state.nh.us/wmb/vlap/2004/documents/ossipee.pdf](http://www.des.state.nh.us/wmb/vlap/2004/documents/ossipee.pdf)
- DES VLAP [2005 Report: www.des.state.nh.us/wmb/vlap/2005/graphs/Ossipee\\_Lake\\_Ossipee\\_Graph.pdf](http://www.des.state.nh.us/wmb/vlap/2005/graphs/Ossipee_Lake_Ossipee_Graph.pdf)
- DES VLAP [2006 Report: www.gmcg.org/administration/pdf/2006%20Ossipee%20Lake%20VLAP%20Report.pdf](http://www.gmcg.org/administration/pdf/2006%20Ossipee%20Lake%20VLAP%20Report.pdf)
- VLAP parameters: [www.des.state.nh.us/wmb/vlap/documents/parameters.pdf](http://www.des.state.nh.us/wmb/vlap/documents/parameters.pdf)
- VLAP manual: [www.des.state.nh.us/wmb/vlap/documents/fieldmanual.pdf](http://www.des.state.nh.us/wmb/vlap/documents/fieldmanual.pdf)

### Other Lake Reports & Lake Associations with Monitoring Programs:

Bearcamp Pond: <http://www.des.state.nh.us/wmb/vlap/2003/documents/BearcampPond.pdf>

Chocorua Lakes Association: <http://www.chocorualake.org/About-Us/index.html>

Silver Lake Association: [http://www.silverlakemadison.com/pdf/silver\\_lake\\_monitoring\\_sites.pdf](http://www.silverlakemadison.com/pdf/silver_lake_monitoring_sites.pdf)

Squam Lakes Association: <http://www.squamlakes.org/index.php>

VLAP reports for other lakes (Dinsmore Pond; Freedom: Duck Pond; Tamworth: Moores Pond; Madison: Pea Porridge Pond; Effingham: Province Lake): <http://www.des.state.nh.us/wmb/vlap/2006/>

## III. Current and Potential Threats to Lakes and Ponds

### A. Milfoil & Exotic, Invasive Species of Plants

*Exotic species* are non-native types that have become introduced either intentionally (e.g., as ornamentals or for sport) or accidentally (e.g., attached to boat hulls or from aquariums).

*Invasive species* are exotics that encounter few restraints to rapid reproduction and spreading. Once introduced, such plants can grow out of control to become a nuisance to human recreational uses for waterbodies to the point of significantly impacting property values. They also replace native plants and habitat, disrupt the food chain, stunt fish growth, and degrade wildlife habitat.



**Chapter V A.3 Figure 2: Variable Milfoil** is the most widespread invasive exotic plant in New Hampshire. (photo NH DES)

According to the NH DES, the most wide-spread invasive exotic plant in the state, variable milfoil, *Myriophyllum heterophyllum* (Figure 2) spread from Lake Winnepesaukee to 38 other waterbodies, primarily through human activity. Live fragments of these plants that are capable of taking root often enter lakes attached to boat hulls, outboard motors, boat trailers, or fishing gear.

#### 1. Ossipee Lake Infestations

Variable milfoil infestations were first discovered in the Ossipee Lake system in the early 1990's. The map in figure 3 highlights locations of known milfoil infestations: Phillips Brook, Leavitt Bay, Portsmouth Cove and Danforth Pond. Nearby infestations in Maine and other states are also of concern since invasive species can survive for many days out of water, attached to boats, trailers, or even the feet, fur, or feathers of mobile wildlife.

For a complete list of infested waterbodies in NH go to:

[http://www.des.state.nh.us/wmb/exoticspeciesmilfoil\\_list.htm](http://www.des.state.nh.us/wmb/exoticspeciesmilfoil_list.htm)

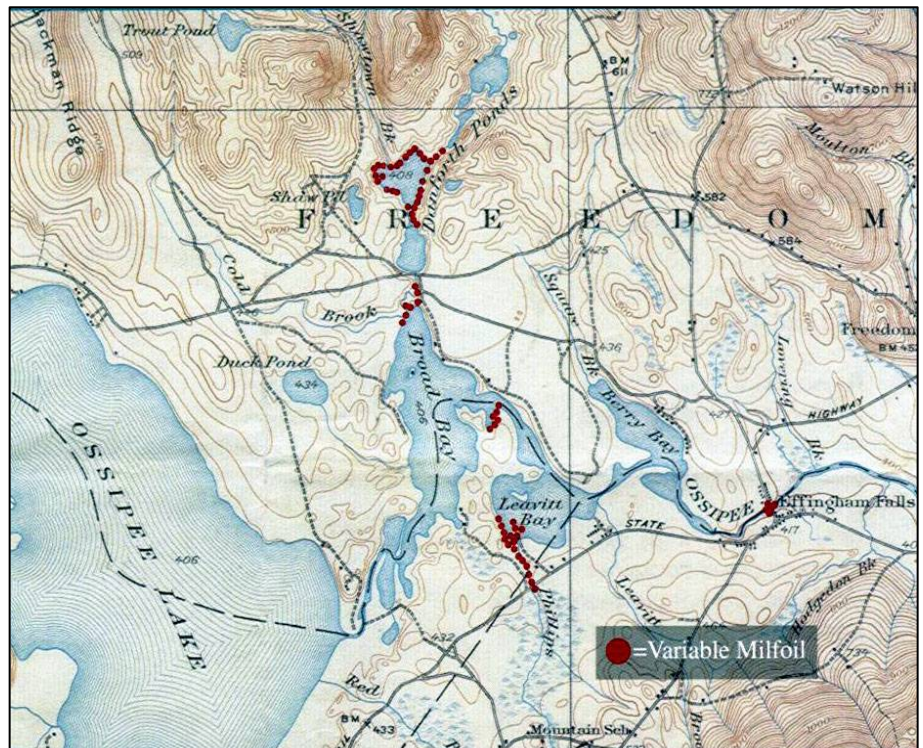

Lists of infested waterbodies in Maine can be found at:  
<http://www.maine.gov/dep/blwq/topic/invasives/doc.htm>

## 2. Treatment & Prevention Programs

**a) Removal Programs.** To date, there is no practical and environmentally safe means of permanently eradicating these plants. Once a waterbody has an infestation, it requires continuous often expensive management and control practices (see local examples in Table 4). Prevention or early detection of new infestations becomes the most important form of defense against the spread of milfoil and other invasives such as fanwort, water chestnut, Eurasian milfoil, purple loosestrife and common reed. Hand pulling, benthic barriers and herbicide treatments can be undertaken with the assistance of the DES. Since 1995, local businesses that depend upon the lake, Ossipee Lake Alliance (OLA), and surrounding towns have used these approaches (charts below), with marginal success at limiting growth. In 2006 New England Milfoil and OLA reported that approximately 25% of the milfoil in Phillips Brook and 5% of the plants in the area where it enters Leavitt Bay came back after hand pulling efforts the previous year.

Contractor	Location	Management Type	Cost	Chemical Application /Treatment Date	Treatment Area (acres)
Lycott Environmental Research	Leavitt Bay/ Phillips Brook Ossipee	Chemical	\$4,730.00 (Total)	Jun-95	6.1 acres
Aquatic control technology		Chemical	\$5,890.00 (total/DES)	Completion date: September 30 <sup>th</sup> 1996	6.1 acres
Cliff Cabral	Broad Bay Freedom	Hand pulling	\$10,000.00 (total) \$5,000.00 (DES 50%)	Summer 2005	4 acres

Chapter V-A.3 Table 4: Milfoil treatment in Ossipee Lake & Bays (source NH DES)

**b) Lake Host Program.** The New Hampshire Lake Association (NHLA) sponsors a Lake Host program that places a “Lake Host” at main boat access points to inspect boats and trailers for weed fragments and to educate the public about this problem. Since 2002, GMCG has hired local youth to prevent new introductions and further spread of exotic aquatic plants (such as variable milfoil) in Ossipee Lake. To date, Lake Hosts have inspected over 2,500 boats at the Pine River boat launch for weed fragments attached to boats, motors, trailers, or fishing gear and provided information to many more boaters about the lake’s milfoil infestations and how they can prevent the spread of exotic plants. Since 2002, at more than 60 lake access ramps statewide, the program has logged 135 “saves” (i.e., instances where invasive fragments have been found and removed prior to launching). Statewide, no new lake infestations have occurred since the program began. Within the Ossipee Watershed, the Ossipee Conservation Commission, Silver Lake Association of Madison, and Sandwich Conservation Commission also conduct Lake Host programs or milfoil inspections at various boat launch sites.

**c) Weed Watchers Program.** OLA participates in the NH DES Weed Watchers program to train volunteers to identify invasive plants and then monitor their local shoreline for new weeds. In 2004,

Alliance Weed Watcher volunteers found three new infestations on the lake that are now being treated. They also created the Exotic Species Prevention program to help the owners of the lake's more than 30 boat ramps - from marinas to campgrounds to condominium associations - increase milfoil awareness among those who use the ramps. In 2004 and 2005 OLA hosted workshops at which boat ramp owners created milfoil prevention plans for their site. Then with funding assistance from the NH DES, OLA helped the owners launch those plans, including distributing a new [milfoil prevention pamphlet](#) created specifically for Ossipee Lake. The Exotic Species Prevention program is an ongoing multi-community initiative involving town officials, conservation organizations and business owners from Freedom, Ossipee and Effingham. Within the Ossipee Watershed, the Silver Lake Association of Madison and Sandwich Conservation Commission also conduct Weed Watchers programs.

**d) Long Term Variable Milfoil Management.** In 2007, NH DES will be working with GMCG, OLA, towns, property owners and other stakeholders to review all of the information collected to date. All of the information collected will be thoroughly investigated and compiled into a Long-Term Variable Milfoil Management Plan for Lake Ossipee. . All infested waterbodies need such a comprehensive management plans in place before further management practices (particularly herbicides) are approved. Continued diligence in the form of educating boaters and lakefront homeowners and keeping infestations from spreading will be essential to preventing new infestations from occurring in the lake system or spreading to other sites.

#### **Helpful Links:**

Aquatic Plants & Algae in NH:<http://www.des.state.nh.us/wmb/ExoticSpecies/documents/PlantBook.pdf>

GMCG Lake Host Program: [www.gmcg.org](http://www.gmcg.org)

NH DES contact: Amy P. Smagula, (603) 271-2248 [asmagula@des.state.nh.us](mailto:asmagula@des.state.nh.us)

NH DES Chart of Exotic Species: [www.des.state.nh.us/wmb/ExoticSpecies/index.html](http://www.des.state.nh.us/wmb/ExoticSpecies/index.html)

NH Lakes Association/Lake Host Program: [www.nhlakes.org/](http://www.nhlakes.org/) ; <http://www.nhlakes.org/docs/06-LH-Manual-Org-List.doc>

OLA/Weed Watcher Program: June D'Andrea, (603)539-1643 [jmdandrea@ossipeelake.org](mailto:jmdandrea@ossipeelake.org);  
[www.ossipeelake.org](http://www.ossipeelake.org) :

Silver Lake Association of Madison: <http://www.silverlakemadison.com/>

## **B. Water Pollution**

### **1. Non-point Source (NPS) pollutants**

There are two categories of water pollution associated with natural and human causes that can degrade the quality of lakes and ponds: **Point source pollutants** that are derived from specific entry locations (e.g., effluent pipes, dump sites), and **non-point source pollutants**, which include substances generally distributed in the landscape that find their way into aquatic systems as precipitation waters wash over land surfaces. Point sources of pollution are often obvious and usually the first to be dealt with. In the Ossipee Watershed, NPS pollution is a greater threat to the water quality of lakes and ponds. Some examples and causes of NPS pollution include:

- **sand** and **salt**, which may come from winter road maintenance
- **oil** and **gas**, which may come from spills at home or leaks on the road
- **nutrients**, such as from uncovered manure piles, leaky septic systems, or excessive use of fertilizers
- **sediment**, which may come from natural or manmade erosion, construction sites, or clearcuts
- **litter, pesticides, insecticides, and herbicides.**
- **metals** such as **mercury** and increased **acidity** as precipitation/atmospheric fallout
- **bacteria** such as *E. coli* from leaking septic systems, excessive concentrations of waterfowl

Table 5 highlights the major causes of impairments for lakes and ponds in New Hampshire, their sources, and the risk to humans and the environment.

**Chapter V-A.3 Table 5. Statewide New Hampshire Top Causes of Impairments for Lakes, Ponds and Reservoirs** (modified US EPA, 2002)

<b>Cause</b>	<b>Source</b>	<b>Risk</b>	<b>NH Total Acres Impacted</b>
<b>Mercury</b>	Atmospheric deposition	Neurotoxic to aquatic life & humans; biological magnification up food chain	187,728.66
<b>Non-native Aquatic Plants</b>	Boats, fishing gear, aquarium waste; some wildlife transport	Loss of native, stabilizing plant species; excessive organic productivity & decomposition; reduced recreation options and reduced land values	70,466.97
<b>Reduced pH</b>	Atmospheric deposition; naturally occurring organic acids from decomposition	Acidification of water; increased nutrient leaching from soils; build-up of metals in water	14,878.87
<b>Polychlorinated Biphenyls (PCBs)</b>	Industrial/Municipal discharges; old power transformers	Carcinogenic; biological magnification up food chain; toxic to aquatic life	14,719.90
<b>Copper</b>	Natural sources; herbicide application	Toxic to aquatic life	2,000.00
<i>Eschericia coli</i>	Septic failures, sewer overflow, excessive waterfowl	An indicator species revealing the potential for the presence of pathogenic organisms	988.03
<b>Excess Algal Growth</b>	Nutrient enrichment; septic, sewer, domestic & agricultural runoff	Cultural eutrophication; excessive decomposition, lowered oxygen, toxic byproducts	618.80
<b>Poor Dissolved Oxygen Saturation</b>	Excessive decomposition from excessive productivity	Anaerobic byproducts; loss of oxygen sensitive aquatic life	508.00
<b>Aluminum</b>	Released from surrounding soil by acidic precipitation	Toxic to aquatic life	485.50
<b>Dioxin (including 2,3,7,8-TCDD)</b>	Industrial & domestic solid waste disposal	Carcinogenic; biological magnification up food chain; toxic to aquatic life	384.10

Research on mercury in fish from local lakes and ponds has shown some local hot spots with elevated mercury levels (see link below to NH DES data). Figure 4 demonstrates the widespread problem of mercury contamination across the United States, highlighting the states with fish consumption advisories due to elevated levels of mercury.



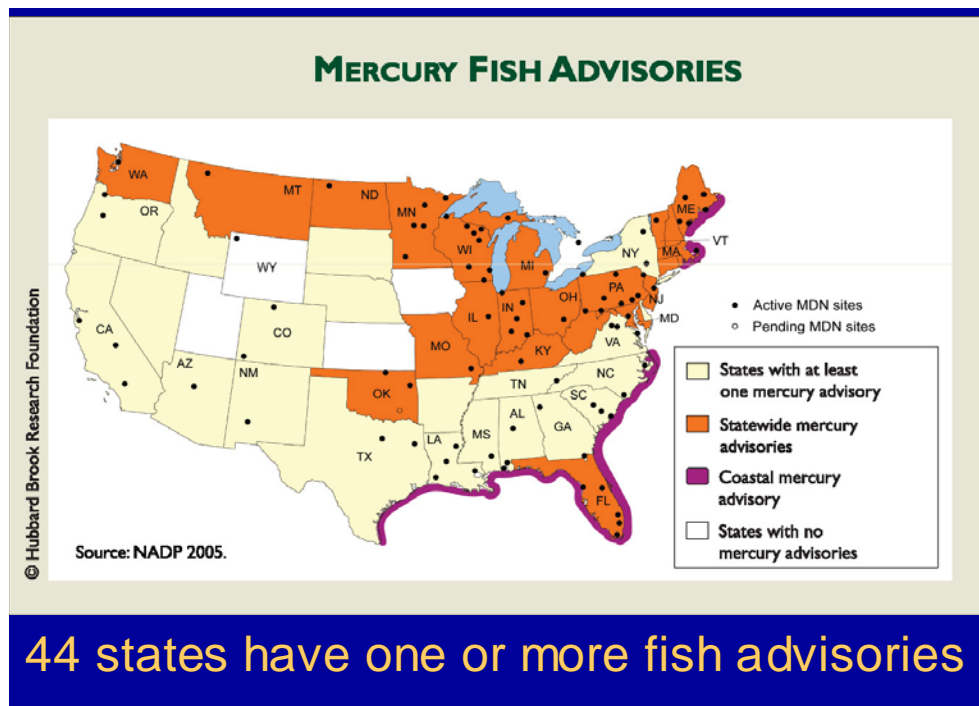

**Chapter V-A.3  
Figure 4:  
States with Fish  
Advisories.**  
States in orange  
have statewide  
mercury  
advisories due to  
mercury.  
(Hubbard Brook  
2007 Mercury  
Report)

Local lakes and ponds are also at risk of *cultural eutrophication*, or the excessive increase in productivity of algal and plant growth of a lake due to the addition of nutrients from human activities such as fertilizing or septic leakage. This is indicated by lower water clarity, algal ‘blooms’, or increases in submerged and/or emergent vegetation.

Another a concern in waterbodies of the Northeast is *acidification*, or reduced pH. This occurs due to acid deposition and low geologically supplied acid neutralizing capacity or buffering in most New Hampshire surface waters. According to the New Hampshire Wildlife Action Plan, acid deposition may have critical effects on species and habitats of conservation concern in the state. Impacts are expected to be soon and serious for montane watersheds, vernal pools, talus slopes and rocky ridges, lowland spruce-fir forests, and hemlock-hardwood-pine forests. Lower pH can negatively impact nearly all levels of the aquatic food web—including bacteria, fungi, algae, zooplankton, invertebrates, fish, and birds. Individual organisms and processes such as embryonic development, growth, metabolism, respiration, reproduction, and survival are negatively impacted by chronic acidity. Overall biodiversity, shifts in species and community composition, and many other complex relationships can also be altered, in addition to the processes of decomposition, primary productivity, and secondary production. Toxic metals such as mercury, aluminum, cadmium and lead can also be mobilized and made more bioavailable as a result of acidification, not only increasing surface water toxicity for aquatic invertebrates and fish, but also the health risk to humans.

## 2. Point Source Pollution

The state of New Hampshire and EPA regulate point sources through the NPDES (National Pollutant Discharge Elimination System) Permit Program. Any facility that discharges directly to a surface water is required to obtain a federal permit, called a National Pollutant Discharge Elimination System (NPDES) permit. The EPA issues these permits because the State of New Hampshire has not yet been delegated by EPA to administer this program. The DES must certify that the limitations and conditions

contained in the NPDES permit will ensure that the proposed discharge will not violate any state law or regulation. NPDES permits in New Hampshire are primarily issued to municipal and industrial wastewater treatment plants.

There are also three general NPDES permits issued to implement the [Federal Storm Water Program](#). For more information about this program, or if there is a concern about water quality conditions downstream of discharges, visit the NPDES website: [www.des.state.nh.us/WWE/resources.htm](http://www.des.state.nh.us/WWE/resources.htm). For a list of activities requiring a state surface water discharge permit, go to: [http://www.des.state.nh.us/rules/env-ws\\_401.pdf](http://www.des.state.nh.us/rules/env-ws_401.pdf). The two NPDES outfalls located in the Ossipee Watershed are 'inactive' (not discharging), according to NHDES, and are:

- Mountain Automotive (aka C.N. Brown Company), a groundwater return to Frenchmans Brook
- Brook in Ossipee/Madison Lumber Mill (aka International Paper) a process wastewater return to the West Branch River

### 3. Altered Hydrology

Water quality and aquatic organisms are greatly influenced by fluctuations in water levels, either from flooding or droughts, whether human induced or naturally occurring. Altered flow regimes from road crossings, impermeable surfaces and development as well as restrictions to flow from impoundments or dams and seasonal lake draw-downs all impact water quality, connectivity and the movement of fish and wildlife. Water flow, temperature, pH, transparency, dissolved oxygen levels, and sedimentation are all impacted by dams, in turn influencing biological communities and species composition. Freshwater fish such as trout and salmon, which migrate upstream to spawn, and freshwater mussels, which depend on fish for dispersal and development, can all be prevented from accessing important habitat. Alterations to lake and river shorelines, to create beaches for example, often cause erosion problems downstream. Culverts can also constrict flow and reduce stream connectivity and inhibit movement to fish, amphibians and some invertebrates. Seasonal draw-down of lakes and ponds in the Ossipee Watershed can negatively impact the spring spawning activity of fish and amphibians as well as flood the nests of shoreline nesting birds such as loons. Impervious surfaces such as parking lots, buildings and roads can also accelerate water movement, intensify flooding, and contribute more pollutants to surface waters, in addition to preventing rainwater from recharging groundwater. Lack of groundwater can be a problem during the hot summer months when surface waters are primarily replenished by groundwater supplies, in turn stressing summer flows and conditions for invertebrates and fish.

The town of Effingham worked with the University of New Hampshire in 2006 to complete a town **culvert study** to determine impediments to water flow and connectivity and make recommendations for how the town could restore natural hydrological patterns. The report can be viewed at: <http://www.gmcg.org/administration/pdf/Effinghamculvertstudy.pdf>.

## IV. Recommendations:

**A. Enforce the Shoreland Protection Act.** The Comprehensive Shoreland Protection Act (CSPA) was enacted by the state in 1994 (and amended in 2007) to protect water quality by preventing soil and other pollutants from entering larger lakes, ponds, rivers, and streams. (For a listing of water bodies covered by CSPA, refer to: [http://www.des.state.nh.us/Dam/DamRemoval/List\\_of\\_Public\\_Waters.pdf](http://www.des.state.nh.us/Dam/DamRemoval/List_of_Public_Waters.pdf)). For these bodies, CSPA sets minimal standards and requirements for the development, use and subdivision

of land within a "protected shoreland" zone, 250 feet of the edge of the state's water bodies, i.e., the "reference line"; a more restricted "natural woodland buffer" zone, within 150 feet of the reference line, and a still more restricted "waterfront buffer" zone within 50 feet of the reference line.

Within the protected shoreland the following restrictions shall apply:

1. The Protected Shoreland within 250 feet of the reference line:
  - impervious surface area is limited to 20% (with some room for limited expansion – refer to details in RSA 483-A)
  - no establishment/expansion of salt storage yards, auto junk yards, solid and hazardous waste facilities.
  - all new lots subject to DES subdivision approval
  - new septic system setbacks range from 75-125 ft depending on soil characteristics
  - minimum lot size depends on septic limit/soil type
  - number of dwelling units may not exceed 1 unit per 150 ft of shoreland frontage
2. Natural Woodland Buffer within 150 feet of the reference line:
  - between 50 and 150 ft, 50% of the area outside of permitted impervious surfaces must be maintained in an undisturbed state
3. Waterfront Buffer within 50 feet of the reference line:
  - all primary and accessory structures must be set back at least 50 ft from the reference line UNLESS the town has established a setback in excess of 50 ft
  - tree cover is managed with a 50 x 50 ft grid-&-point system (refer to the DES website for details). Tree coverage must total 50 points in EACH grid. No cutting of trees or saplings within a grid beyond the 50 point minimum.
  - no natural ground cover shall be removed except for a footpath to the water than does not exceed 6 ft in width
  - No cutting or removal of vegetation below 3 ft in height (excluding lawns) except for the allowable path. Natural ground cover, including the duff layer, shall remain intact.
  - Within 50 ft, stumps, roots, and rocks must remain intact in and on the ground
  - Chemical applications (pesticides, herbicides, etc.) are prohibited. Low phosphorus, slow release nitrogen fertilizer may be used beyond 25 ft from the reference line. No fertilizer, except limestone, between the reference line and 25 ft.

Locally, municipalities may adopt land use control ordinances relative to all protected shorelands that are more stringent than the minimum standards of the CSPA. Municipalities are encouraged to adopt land use control ordinances for the shorelands of water bodies and water courses other than public waters, and may enforce the provisions of the CSPA by issuing cease and desist orders and by seeking injunctive relief or civil penalties as provided in RSA 483-B:18, III(a) and (b). Municipalities bordering the same water body are encouraged to employ jointly a single code enforcement officer to monitor compliance. The authority granted to municipalities under this chapter shall not be interpreted to extend to RSA 430:28-48.

**Shoreland Protection Act:** [www.gencourt.state.nh.us/rsa/html/nhtoc/nhtoc-l-483-b.htm](http://www.gencourt.state.nh.us/rsa/html/nhtoc/nhtoc-l-483-b.htm) and <http://www.des.state.nh.us/sp.htm> for 2007 updates.

***B. Create a Comprehensive Lake Management Plan.*** The future of Ossipee Lake and other waterbodies in the Watershed is threatened by increased recreation and development, as well as associated non-point source pollution and infestations of invasive species of plants. Ossipee Lake does

not currently have a comprehensive management or stewardship plan, although steps have been made in that direction. GMCG and Ossipee Lake Alliance (OLA) established the Lake Environment Assessment Program (LEAP) to identify other significant human-impact issues and track their impact on the environment and the quality of recreation. During the summer of 2003, adult campers and other volunteers established a baseline of data for the program by counting boats, identifying rafting locations, and establishing traffic patterns at various times of day on weekends, weekdays, and holidays. By replicating the counts in future summers, changes from the baseline data may be viewed and assessed.

**C. Enforce Best Management Practices (BMPs).** BMPs delineate proper handling and storage of substances to prevent harmful pollutants from entering surface and groundwater. By implementing these techniques, water quality can be protected by catching and filtering runoff and non-point source pollution before it enters and contaminates waterbodies. BMPs for waterfront property are shown in Table 6:

**Chapter V A.3 Table 6: BMP Checklist for Towns & Waterfront Property Owners**

<input checked="" type="checkbox"/>	Keep septic systems properly maintained. Septic system surveys should be conducted since towns have indicated concern about antiquated or faulty septic systems so these do not impact lake and surface water quality. Anonymous survey sheet example: <a href="http://www.des.state.nh.us/wmb/VLAP/documents/SepticSystemSurvey.pdf">www.des.state.nh.us/wmb/VLAP/documents/SepticSystemSurvey.pdf</a>
<input checked="" type="checkbox"/>	Document any algal blooms that may be observed in September in October, collecting a sample for the DES lab if one should occur. <a href="http://www.des.state.nh.us/lab/index.html">www.des.state.nh.us/lab/index.html</a>
<input checked="" type="checkbox"/>	Minimize the clearing of vegetation and leave buffer strips above and below clearings.
<input checked="" type="checkbox"/>	Keep grass cut high.
<input checked="" type="checkbox"/>	Use native or low maintenance shrubs minimizing the need for fertilizer, water and other amendments.
<input checked="" type="checkbox"/>	Get soil tested before applying any fertilizers or amendments.
<input checked="" type="checkbox"/>	Dispose of waste materials properly.
<input checked="" type="checkbox"/>	Reduce nutrient loading to the lake by eliminating fertilizer use on lawns and keeping the lake shoreline natural, or use low or no phosphorous slow release nitrogen blends.
<input checked="" type="checkbox"/>	Store and apply dangerous materials with care.
<input checked="" type="checkbox"/>	Limit impervious surfaces on property.
<input checked="" type="checkbox"/>	Use drains, swales and waterbars.
<input checked="" type="checkbox"/>	Divert any water flow into vegetated areas.
<input checked="" type="checkbox"/>	Minimize the use of road salt and snow dumping near waterbodies, or seek alternative forms of treatment. <a href="http://www.nh.gov/dot/bureaus/highwaymaintenance/documents/WinterMaintSnowandIcePolicy.pdf">http://www.nh.gov/dot/bureaus/highwaymaintenance/documents/WinterMaintSnowandIcePolicy.pdf</a>
<input checked="" type="checkbox"/>	Do not add sand, dredge or fill shoreline areas.
<input checked="" type="checkbox"/>	Where new beaches are desired, waterfront property owners should look into perched beaches to protect the lake from sand deposition, the leading cause of lake quality degradation. <a href="http://www.des.state.nh.us/WMB/VLAP/2006/Appendix_D.pdf">www.des.state.nh.us/WMB/VLAP/2006/Appendix_D.pdf</a>

## *A Local Example of Successful Lake Management and Utilization of BMPs*

In 2000, the Chocorua Lake Association worked with the UNH Lakes Lay Monitoring Program, NH DOT, and Town of Tamworth to initiate the model Chocorua Lake Project to monitor the impact of non-point source (NPS) pollutants on Chocorua Lake within the Ossipee Watershed and explore effective



**Chapter V A.3 Figures 6 & 7: BMPs at Lake Chocorua.** Berms and swales successfully prevent pollutants from entering Chocorua Lake. (source: Bob Cravcraft. UNH)

control methods. They used volunteer-assisted sampling to construct water and nutrient (total phosphorus) budgets to locate critical pollutant runoff areas as well as critical areas of importance for NPS control in the watershed surrounding Chocorua Lake. The NPS pollutants (sediments, phosphorus, and nitrogen) were reduced by 90+% during spring runoff conditions by using properly designed road runoff BMPs (Figures 6 & 7) such as stone-lined waterways, retention basins, plunge pools, and diversions. During a major fall storm/flooding event (100 year storm), these techniques reduced loading by more than 50%. This result also demonstrates the importance of the wetland complexes that occur throughout the watershed. These areas were then targeted for land protection efforts. This study became a model demonstration project and BMP workshop for road agents from New Hampshire, Maine, and Massachusetts in 2003.

**Chocorua Lake Project:** Jeffrey A. Schloss, Water Resources Specialist/Research Scientist, UNH; [jeff.schloss@unh.edu](mailto:jeff.schloss@unh.edu) [www.nhlakes.org/lake-monitoring.htm](http://www.nhlakes.org/lake-monitoring.htm); [www.epa.gov/nps/Section319III/NH.htm](http://www.epa.gov/nps/Section319III/NH.htm)

**D. Monitor Water Quality.** Water quality professionals recommend long-term monitoring of lakes and ponds, including frequent and regular sampling to help pinpoint potential sources of pollution and to track water quality trends. Water quality trend analysis is not feasible with only a few data points. It takes many years to develop a meaningful set of water quality baseline data. In the 2007 biennial annual report, at which time Broad Bay and Leavitt Bay will have been sampled for at least ten consecutive years, DES will report a statistical analysis of the historical data to objectively determine if there has been a significant change in the annual mean levels of parameters that are measured. (For more in depth coverage of water quality monitoring in the Ossipee Watershed's lakes and ponds, visit Chapter V-a.)

**E. Encourage Low Impact Development.** Communities can encourage developers, residents and businesses to utilize low-impact development (LID) techniques. LID is an approach to site development and design that takes into consideration stormwater infiltration and the natural hydrology of a watershed to protect water quality, prevent flooding, increase groundwater recharge rates, and prevent negative impacts on wildlife and wildlife habitat.

For more information and examples, visit: <http://www.des.state.nh.us/factsheets/wmb/wmb-17.htm>.

## V. Helpful Links:

NH DES Fish Mercury Data for Lakes & Ponds in the Ossipee Watershed:

<http://www.gmcg.org/administration/pdf/Ossipee%20Watershed%20Fish%20Mercury%20Data.pdf>

NH Dept. of Health & Human Services “safe eating guidelines” for fish caught in inland waters: [www.dhhs.state.nh.us/bhra](http://www.dhhs.state.nh.us/bhra)

Hubbard Brook Studies:

[http://www.hubbardbrook.org/research/current/projects/streams/stream\\_99.htm#manip](http://www.hubbardbrook.org/research/current/projects/streams/stream_99.htm#manip)

Biodiversity Research Institute studies & reports:

<http://www.briloon.org/monitor/glimmr.htm>

[http://www.briloon.org/pub/doc/wcv\(2004-05\).PDF](http://www.briloon.org/pub/doc/wcv(2004-05).PDF)

[http://www.briloon.org/pub/doc/Kamman\\_etal\\_Hg\\_VTNH\\_Lakes.pdf](http://www.briloon.org/pub/doc/Kamman_etal_Hg_VTNH_Lakes.pdf)

[http://www.briloon.org/pub/doc/SNH\(2001-06\).PDF](http://www.briloon.org/pub/doc/SNH(2001-06).PDF)

Fact Sheets for Shoreland Protection: <http://www.des.state.nh.us/sp.htm>; <http://www.des.state.nh.us/cspa/>

Lake Ecology information: <http://www.nhlakes.org/limnology.htm>

NH DES Lab: [www.des.state.nh.us/lab/index.html](http://www.des.state.nh.us/lab/index.html)

OLPP/LEAP Report 2003: [www.gmcg.org/administration/pdf/OLPPReport2003.pdf](http://www.gmcg.org/administration/pdf/OLPPReport2003.pdf)

Perched Beaches: [www.des.state.nh.us/WMB/VLAP/2006/Appendix\\_D.pdf](http://www.des.state.nh.us/WMB/VLAP/2006/Appendix_D.pdf)

Septic System Survey: [www.des.state.nh.us/wmb/VLAP/documents/SepticSystemSurvey.pdf](http://www.des.state.nh.us/wmb/VLAP/documents/SepticSystemSurvey.pdf)

### **New Hampshire Department of Environmental Services (NH DES) On-Line Resources.**

The New Hampshire Department of Environmental Services website (<http://www.des.state.nh.us/>) offers easily accessible information regarding responsibilities and opportunities for state, municipal, and individuals to address water resource issues. Here are brief summaries of just some of these links that relate to Sanding Water issues.

#### SURFACE WATER QUALITY – LAKES:

1. Dam Bureau – Public Waters maintains the Official List of Public Waters (OLPW). This document lists great ponds and artificial impoundments of 10 acres or more in the State of New Hampshire. The State owns the beds of all great ponds, up to the elevation of natural mean high water. This site includes: statutory definitions of public waters, the Official List of Public Waters, and the natural mean high water elevations at a few of the great ponds. Visit:

[http://www.des.state.nh.us/Dam/public\\_waters.htm](http://www.des.state.nh.us/Dam/public_waters.htm)

2. Exotic Species Program describes Long-Term Management Plans for Exotic Aquatic Plants. The Department of Environmental Services will take the lead in drafting the management plans, but it will include input from the lake residents, municipalities, Fish and Game, and other stakeholders in the health and integrity of the waterbody and its surroundings. By spring of 2007, for example, a total of 19 draft plans were prepared. Contact Amy Smagula at (603) 271-2248 or [asmagula@des.state.nh.us](mailto:asmagula@des.state.nh.us) for more information on preparing a plan for your lake. Visit:

[http://www.des.state.nh.us/WMB/ExoticSpecies/management\\_plan\\_info.htm](http://www.des.state.nh.us/WMB/ExoticSpecies/management_plan_info.htm)

3. Selling Developed Waterfront Property - Site Assessment Study Required is required prior to executing a purchase and sale agreement for any "developed waterfront property" using a septic disposal system that is contiguous to or within 200 feet of a great pond (a public water body of more than 10 acres). An owner must engage a permitted subsurface sewer or waste disposal system designer to perform an on-site assessment study. For more information, visit:

<http://www.des.state.nh.us/factsheets/ssb/ssb-10.htm>

4. Watershed Management Bureau coordinates several lake water quality assessment programs. Studies include acid rain-related parameters along with trophic status reports. The Volunteer Lake Assessment Program (VLAP) is included here, as are the biannual Water Quality reports to the Congress, as mandated by the Clean Water Act. Look here for information on:

Beach monitoring programs, the Clean Lakes Program, dock permits, exotic weeds, waterfront property assessments, clean drinking water standards, and more.

Visit: [http://www.des.state.nh.us/wmb/lakes/lake\\_water/](http://www.des.state.nh.us/wmb/lakes/lake_water/)

5. Watershed Management Bureau - Lakes Management and Protection Program are designed to reinforce state and federal water quality laws. In addition, they are to maintain or enhance the scenic beauty, wildlife habitat, and recreational potential of the state's waters for the public. This site describes:

- state level management criteria for lakes that would form the basis for state agency decisions regarding lakes management and protection
- provide and exchange technical assistance among state and federal agencies and public and private sectors regarding lakes management and related issues.
- Visit: <http://www.des.state.nh.us/wmb/lakes/>

6. Watershed Management Bureau - Surface Water Quality Assessments [305(b) and 303(d)] are two surface water quality documents that the federal Clean Water Act (CWA) requires each state to submit to the U.S. Environmental Protection Agency (EPA) every two years. The "305(b) Report" describes the quality of its surface waters and an analysis of the extent to which such waters provide for the protection and propagation of a balanced population of shellfish, fish, and wildlife, and allow recreational activities in and on the water. The second document, the "303(d) List," includes surface waters that are impaired or threatened by a pollutant or pollutant(s) and not expected to meet water quality standards within a reasonable time even after application of best available technology standards for point sources or best management practices for non-point sources. Such water bodies require development and implementation of a comprehensive water quality study (a Total Maximum Daily Load (TMDL) study) which is designed to meet water quality standards. In this section find: full describes of the Section 305(b) and 303(d) Surface Water Quality Reports, guidelines on sediments and water quality standards for public waters, and a description of New Hampshire Volunteer Lake Assessment Program (VLAP). This program establishes a regular volunteer-driven lake sampling program to assist DES in evaluating lake quality throughout the state. You will also find copies of annual reports on the water quality of New Hampshire's lakes here.

Visit: <http://www.des.state.nh.us/WMB/VLAP/>

7. Watershed Management Bureau - Section 401 (Water Quality Certification) of the federal Clean Water Act (CWA), requires any applicant for a federal license or permit to conduct any activity including, but not limited to, the construction or operation of facilities which may result in any discharge into navigable waters, to provide the licensing or permitting agency with a certification from the state where the discharge originates or will originate, that the discharge will meet state surface water quality standards. The 401 Certification is issued prior to the initiation of any work in or near a surface waterbody. Projects that likely require a 401 Certificate include, but are not limited to, road construction or subsurface pipeline installation over or near surface waters, such as rivers and lakes; construction projects that require dredge or fill of a wetland; and hydroelectric power developments that require licensing. This site provides information regarding submission of information required by the 401 Certificate Review Process. Visit: <http://www.des.state.nh.us/WMB/Section401/whatis.html>

**8. Shoreland Protection – Comprehensive Shoreland Protection Act** describes legislation governing development within 250 feet of the states natural or artificially impounded fresh water bodies, tidally influenced coastal waters, and rivers of 4<sup>th</sup> order or higher. The 2007 state legislature adopted important amendments to original act of 1994. Visit: <http://www.des.state.nh.us/cspa/>

## **VI. References**

Anonymous. "January is National Radon Awareness Month." *Environmental News*. New Hampshire Department of Environmental Services, January/February 2007.

Anonymous. "More Milfoil Pulled." *Ossipee Lake Report*. Ossipee Lake Alliance, October-December 2006.

Anonymous. "Shoreland Act Studied." *Environmental News*, New Hampshire Department of Environmental Services, January/February 2007.

Craycraft, Robert. "2006 Ossipee Watershed Presentation". *State of the Watershed Presentation*, 17 November, 2006.

Driscoll, Charles, Evers, David, and Holsen, Thomas. *Mercury Matters: Linking Mercury Science with Public Policy in the Northeastern United States*. Hubbard Brook Research Foundation, 2006.

Haines, T.A. 1981. Acidic Precipitation and Its Consequences for Aquatic Ecosystems: A Review". *Transactions of the American Fisheries Society* 110:669-707.

New Hampshire Department of Environmental Services, *Surface Water Quality Assessments [305(b) and 303(d)]*, 2006.

New Hampshire Department of Fish & Game. *New Hampshire Wildlife Action Plan*. October 1, 2005.

New Hampshire Lake Association. "Estimates of Select Economic Values of New Hampshire Lakes, Rivers, Streams and Ponds." *Phase II Report on the Economic Value of NH's Surface Waters*, June 2003.

New Hampshire Lakes Association. "Watershed Districts and Ordinances." *Lakeside*. New Hampshire Lakes Association, March/April 2007.

Society for the Protection of New Hampshire Forests. *New Hampshire's Changing Landscape: Population Growth, Land Use Conversion, and Resource Fragmentation in the Granite State*. 1999.

## **VII. Model Ordinances for Surface Water Protection.**

Two current approaches serve as alternative models for the protection of the surface waters. In some cases, municipalities have adopted a comprehensive ordinance to address a number of related concerns regarding surface water quality. An example is The Water Quality Protection Ordinance ([http://www.newdurhamnh.us/Land\\_Use/Zoning\\_Ordinance/2007%20Zoning%20Ordinance.pdf](http://www.newdurhamnh.us/Land_Use/Zoning_Ordinance/2007%20Zoning%20Ordinance.pdf)) adopted by New Durham, NH (see Rivers & Streams Section A.4 VII. for the full ordinance).



Other communities have chosen to address related subtopics individually. For example, The Ten Towns Committee in northern New Jersey follows this approach with specific model ordinances regarding Stormwater Runoff, Soil Erosion, Stream Buffers, and Wetland Protection. Their models may be viewed at <http://tentowns.org/10t/mointro.htm>.

The New Hampshire Regional Environmental Planning Program (REPP) is at work preparing an *Innovative Land Use Planning Techniques* Guide. A draft chapter from that Guide related to Shoreland Protection is available for review at the NH DES website: (<http://www.des.nh.gov/repp/index.asp?go=ilupth>). This chapter, including a model ordinance, is designed to assist communities that wish to adopt more stringent regulations for the protection of streams and surface water bodies than those currently prescribed by the state's Comprehensive Shoreland Protection Act, CSPA (RSA 483-B). For example, smaller, often headwater, streams are abundant parts of the landscape throughout the Ossipee Watershed. These first, second, and third order streams are not currently included in the CSPA, yet they are especially vulnerable to sedimentation, pollution, and elevated temperatures/lowered oxygen. Eventually, they pass their cumulative contents along to larger downstream water bodies. Municipalities may also wish to define surface water protection standards that exceed those required by CSPA with regard to setbacks, percent impervious surface limitations, stormwater management plans for earth movement and excavation, permitting for water-dependent structures such as docks, breakwaters, boathouses, marinas, etc.

## MODEL ORDINANCE FOR SHORELAND AND RIPARIAN PROTECTION

Shoreland Zoning Ordinance for the Municipality of \_\_\_\_\_

### I. TITLE AND AUTHORITY

**a. Title:** This Ordinance shall be known as the “Shoreland Protection District of the City/Town of \_\_\_\_\_, New Hampshire.”

**b. Authority:** Pursuant to the authority granted by RSA 483-B:8, Municipal Authority; RSA 674:17 I., Purposes of Zoning Ordinances; and RSA 674:21 I., Innovative Land Use Controls this ordinance is hereby adopted by the Town/City of \_\_\_\_\_, New Hampshire to protect the public health, safety, and general welfare.

### II. PURPOSE

The purpose of this Ordinance is to establish regulations for the design of riparian buffers to protect the flowing streams and surface water bodies of the Town/City of \_\_\_\_\_ to protect the water quality of these resources; to protect the Town/City of \_\_\_\_\_’s riparian and aquatic ecosystems; and to provide for the environmentally sound use of the Town/City of \_\_\_\_\_’s land resources.

### III. FINDINGS

The City/Town of \_\_\_\_\_, New Hampshire finds that shoreland protection and riparian buffers adjacent to flowing waters and surface water bodies provide numerous environmental benefits. Shoreland forested buffers serve to:

- a) Restore and maintain the chemical, physical and biological integrity of the water resources.
- b) Provide infiltration of stormwater runoff.
- c) Remove pollutants delivered in stormwater runoff.
- d) Reduce erosion and control sedimentation.
- e) Stabilize lake and stream banks.
- f) Maintain base flow of streams.
- g) Contribute food and habitat for the aquatic ecosystem.
- h) Moderate the temperature of near shore waters.
- i) Provide and enhance terrestrial wildlife habitat.
- j) Enhance scenic value and recreational opportunities.

Therefore, the City/Town of \_\_\_\_\_, New Hampshire adopts this ordinance to protect and maintain the native vegetation along the shorelands of the community's water courses and surface waters by implementing standards for protection, use and development of these areas within the jurisdiction of the municipality.

#### IV. APPLICABILITY

a) **Shoreland Protection District.** The Shoreland Protection District of the City/Town of \_\_\_\_\_, New Hampshire is an overlay district superimposed over the existing conventional zoning districts of the municipality. It includes within its boundary a protected shoreland on either side of all 1<sup>st</sup>, 2<sup>nd</sup>, 3<sup>rd</sup> and 4<sup>th</sup> order and higher rivers and streams, and a protected shoreland adjacent to all natural and impounded lakes and ponds and coastal estuaries (if applicable) located within the municipality. The Shoreland Protection District does not apply to wetlands, ephemeral streams, beaver impoundments, fire ponds, and farm ponds as defined in this ordinance. The Shoreland Protection District subject to this Ordinance shall be shown on the municipality's **Official Shoreland Zoning Map**, which is incorporated as part of this Ordinance.

b) **Official Shoreland Zoning Map.**

1. **Scale of Map.** The Official Shoreland Zoning Map shall be drawn at a scale of not less than 1 inch = 2,000 feet. District boundaries shall be clearly delineated and a legend indicating the symbols for each district shall be placed on the map.

**[Margin Note: Because of map scale or other reasons, a municipality may have a series of maps instead of one map depicting its shoreland protection district. The state's regional planning commissions are available to assist your municipality in preparing this map. A reliable source of stream location and stream order classification, i.e. the identification of first, second, third and fourth and higher streams within your municipality is available from the New Hampshire Hydrography Dataset (NHHD) developed by Complex Systems Research Center, University of New Hampshire. The final report of the commission reviewing the effectiveness of the CSPA recommends that the state adopt the NHHD for the purpose of identifying stream order.**

**Planning boards are encouraged to include in their site plan and subdivision regulations, requirements for the submittal of surveyed plans depicting the true location of the streams, rivers and other water bodies subject to this ordinance within the subject property. This plan information can then be used to supplement the NHHD data.]**

[Margin Note: Other reliable mapping resources include:

*Stream Buffer Characterization Data and Maps*

Town specific maps that assess 150 and 300 buffer areas

Online: [www.nhep.unh.edu/resources/actions.htm](http://www.nhep.unh.edu/resources/actions.htm)

*Buffer Data Mapper*

Demonstrates the land area impact of various buffer widths

Online: <http://mapper.granit.unh.edu/viewer.htm>

*List of New Hampshire Fourth Order Streams and Higher,  
Revision of May 5, 1995.*

Online: [www.des.state.nh.us/cspa/fourth.htm](http://www.des.state.nh.us/cspa/fourth.htm)

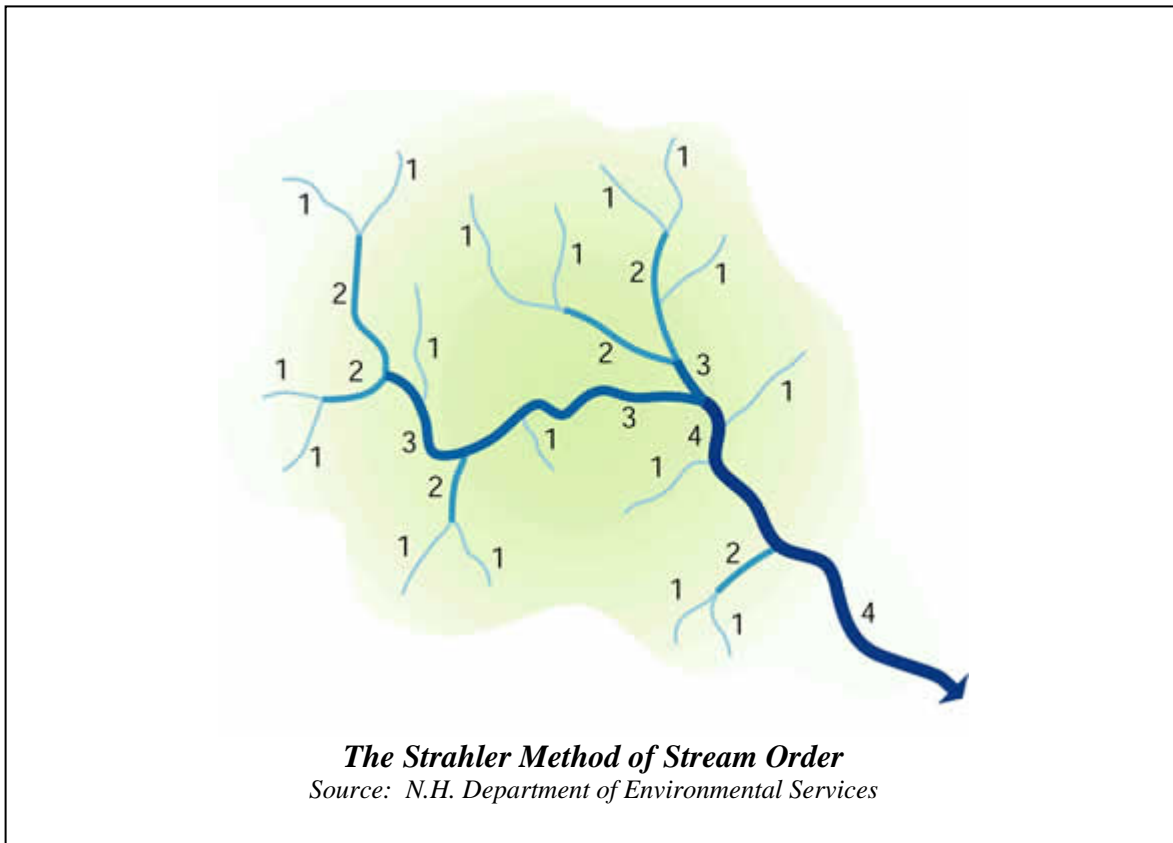

2. **Certification of Official Shoreland Zoning Map.** The Official Shoreland Zoning Map shall be certified by signature of the Municipal Clerk and shall be located in the Municipal Planning Office. In the event the municipality does not have a planning office, the Municipal Clerk shall be the custodian of the map.
3. **Changes to the Official Shoreland Zoning Map.** If amendments are made to the Shoreland Protection District or other matters portrayed on the Official Shoreland Zoning Map, such changes shall be made on the map within 30 days after the amendment has been adopted by the municipality.

## V. DISTRICT BOUNDARIES

- a) **Definition of District Boundaries.** The district boundaries of the Shoreland Protection District shall encompass all land within a horizontal distance of **150** feet of the reference line of any 1<sup>st</sup> and 2<sup>nd</sup> order stream, and **250** feet of the reference line of any 3<sup>rd</sup> and 4<sup>th</sup> order stream and higher, lake, pond or coastal estuary as defined by this Ordinance.
- b) **Interpretation of District Boundaries.** Where uncertainty exists as to the exact location of district boundary lines, the City/Town Code Enforcement Officer with the assistance of the N.H. Department of Environmental Services shall be the final authority as to boundary locations.

**[Margin Note: Municipalities are encouraged to incorporate specific written descriptions of district boundaries into this Ordinance so that disputes over boundaries are minimized. The Official Shoreland Zoning Map is only one of the primary tools in determining district boundaries. Other tools include actual field verification of the reference line. This is where the assistance of DES will be the most useful.]**

## VI. DEFINITIONS

**Accessory Structure or Use** – A use or structure located on the same lot and customarily incidental and subordinate to the primary structure, including but not limited to paths, driveways, patios, any other improved surface, pump houses, gazebos, woodsheds, garages, or other outbuildings. A deck or similar extension of the primary structure or a garage attached to the primary structure by a roof or a common wall is considered part of the primary structure.

**Base flow** – The groundwater contribution to stream flow arising from submerged springs and seeps.

**Beaver Impoundment** - An area this is generally inundated most of the year as a result of flowing water impounded by a beaver dam. Beaver impoundments and the meadows that develop when the dams are not kept up and deteriorate are generally considered wetlands.

**Best Management Practices (BMPs)** – A proven or accepted structural, non-structural, or vegetative measure the application of which reduces erosion or sedimentation, stabilizes stream channels, or reduces peak storm discharge, or improves the quality of stormwater runoff, or diminishes the quantity of stormwater runoff flowing to a single location by using multiple BMPs at separate and dispersed locations. BMPs also include construction site maintenance measures such as removing construction debris and construction waste from construction sites and disposing of debris and waste appropriately in order to reduce contamination of stormwater runoff.

**Boat Slip** – On water bodies over 10,000 acres, means a volume of water 25 feet long, 8 feet wide, and 3 feet deep as measured at normal high water and located adjacent to a structure to which a watercraft may be secured. On water bodies of 10,000 acres or less, a volume of water 20 feet long, 6 feet wide, and 3 feet deep as measured at normal high water mark and located adjacent to a structure to which a watercraft may be secured (RSA 482-A:2 VIII.).

**Buffer** – A vegetated area, including trees, shrubs and herbaceous vegetation, which exists or is established to protect a stream, river, lake, pond, reservoir, or coastal estuarine area.

**Canopy** – The more or less continuous vegetative cover formed by tree crowns in a wooded area.

**Disturbed Area** – An area in which natural vegetation is removed, exposing the underlying soil.

**Ephemeral Stream** – A drainage feature that carries only stormwater in direct response to precipitation with water flowing only during and shortly after large precipitation events. An ephemeral stream may or may not have a well defined channel, the aquatic bed is always above the water table, and stormwater runoff is the primary source of water. An ephemeral stream typically lacks the biological, hydrological, and physical characteristics commonly associated with the continuous or intermittent conveyance of water.

**Estuaries** – A tidal wetland whose vegetation, hydrology or soils are influenced by periodic inundation of tidal waters.

**Farm Pond** - A small, shallow (3-14 foot) artificial impoundment maintained for private recreational use, such as fishing or swimming, or to provide water for livestock, irrigation, or other agricultural uses. Such ponds may be addressed as part of an approved USDA Natural Resources Conservation Service conservation plan and as such do not need to be protected by this Ordinance.

**Fire Pond** – A small, naturally-occurring or artificially constructed water body designated and maintained for the purpose of providing water for fire suppression, characterized by large-vehicle access to the water's edge throughout the year and/or the presence of a dry hydrant. Typically such ponds have been identified or designated by the municipality's fire department as a fire pond.

**First Order Streams** – Are intermittent and perennial streams identified as either dashed lines or solid lines on the New Hampshire Hydrography Dataset (NHHD) or the most recent edition of USGS topographic maps, where mapped.

**[Margin Note: Defining “First Order Streams” is perhaps the most difficult issue in developing this ordinance. This model ordinance defines first order streams as both intermittent and perennial streams because these streams are the most important headwater streams within a watershed. However, municipalities may elect to limit the application of this ordinance to “perennial” streams only. To accomplish this, intermittent streams would need to be excluded from the definition of first order streams. This would require revisions to the NHHD database, because intermittent streams are currently identified as first order streams in this database.]**

**Forest Management** – The application of scientific and economic principles to conserve forest resources and obtain forest benefits.

**Great Pond** – All natural bodies of fresh water situated entirely in the state having an area of 10 acres or more are state-owned public waters, and are held in trust by the state for public use; and no corporation or individual shall have or exercise in any such body of water any rights or privileges not common to all citizens of this state; provided, however, the state retains its existing jurisdiction over those bodies of water located on the borders of the state over which it has exercised such jurisdiction (RSA 271:20).

**Ground Cover** – Any herbaceous or woody plant that normally grows to a mature height of two feet or less, especially mat-forming vegetation which stabilizes the soil.

**Headwater Streams** – Intermittent streams and perennial streams of first and second order.

**Impervious Surface** – Any areas covered by material that impedes the infiltration of water into the soil. Examples of impervious surfaces include buildings, roofs, decks, patios, and paved, gravel, or crushed stone driveways, parking areas, and walkways.

**Intermittent Streams** – A well-defined channel that contains water for only part of the year, typically during winter and spring when the aquatic bed is below the water table. The flow may be heavily supplemented by stormwater runoff. An intermittent stream often lacks the biological and hydrological characteristics commonly associated with the conveyance of water. Intermittent streams (or portions thereof) are portrayed as dashed blue lines on a USGS topographic map, where mapped).

**Lake** – A natural or impounded inland body of fresh water. May also be called a pond or great pond.<sup>1</sup>

**Lot of Record** – A legally created parcel, the plat or description of which has been recorded at the registry of deeds for the county in which it is located.

**Marina** – A commercial waterfront facility whose principal use is the provision of public services such as the securing, launching, storing, fueling, servicing, repairing and sales of watercraft equipment and accessories.

**Natural Vegetation** – All existing live woody and herbaceous trees, shrubs, and other plants.

**Natural Woodland Buffer** – Is defined in the CSPA, RSA 483-B as a forested area consisting of various species of trees, saplings, shrubs, and ground covers in any combination and at any stage of growth.

**Non-Conforming Lot** – A single lot of record which, at the effective date of adoption or amendment of this Ordinance, does not meet the dimensional requirements of the district in which it is located.

**Non-Conforming Structure** – A structure which does not meet any one or more of the following dimensional requirements; setback, height, or lot coverage, but which is allowed solely because it was in lawful existence at the time this Ordinance or subsequent amendments take effect.

**Non-Conforming Use** – Use of buildings, structures, premises, land or parts therefore which is not permitted in the district in which it is situated, but which is allowed to remain solely because it was in lawful existence at the time this Ordinance or subsequent amendments take effect.

**Mean High Water Level** – See Reference Line definition.

---

<sup>1</sup> The terms lakes and ponds are commonly used interchangeably, however, a lake can be distinguished from a pond because a lake contains a thermocline layer while a pond does not.

**Ordinary High Water Mark** – Means the line on the shore, running parallel to the main stem of the river or stream, established by the fluctuations of water and indicated by physical characteristics such as a clear, natural line impressed on the immediate bank, shelving, changes in the character of soil, destruction of terrestrial vegetation, the presence of litter and debris, or other appropriate means that consider the characteristics of the surrounding areas.

**Perennial Streams** – A stream that normally flows year round because it is sustained by groundwater discharge as well as by surface water. A perennial stream exhibits the typical biological, hydrological, and physical characteristics commonly associated with the continuous conveyance of water. Perennial streams (or portions thereof) are portrayed as solid blue lines on a USGS topographic map, where mapped.

**Pond** – Means a natural or impounded still body of water. The term is often used interchangeably with “lake.”

**Primary Structure** – A structure built for the support, shelter or enclosure of persons, animals, goods, or property of any kind, as well, as anything constructed or erected with a fixed location on or in the ground, exclusive of fences. The primary structure is central to the fundamental use of the property and is not accessory to the use of another structure on the same premises.

**Protected Shorelands** – The area subject to this Ordinance.

**Public Waters** – See CSPA, RSA 483-B:4, Definitions.

**Reference Line** – Is defined in the CSPA, RSA 483-B and under this Ordinance as follows:

- (a) For natural fresh water bodies without artificial impoundments, the natural mean high water level as determined by the NH Department of Environmental Services.
- (b) For artificially impounded fresh water bodies with established flowage rights, the limit of the flowage rights, and for water bodies without established flowage rights, the waterline at full pond as determined by the elevation of the spillway crest.
- (c) For coastal waters, the highest observable tide line, which means a line defining the furthest landward limit of tidal flow, not including storm events, recognized by indicators such as the presence of a strand line of flotsam and debris, the landward margin of salt tolerant vegetation, or a physical barrier that blocks further flow of the tide.
- (d) For third and fourth order and higher rivers and streams, the ordinary high water mark.
- (e) For first and second order streams, the extent of the defined channel.

**Removal or Removed** – Cut, sawed, pruned, girdled, felled, pushed over, buried, burned or otherwise destructively altered.

**Riparian Area** – The area of land adjacent to the shoreline or bank of a stream, river, pond, lake, bay, estuary, or other similar body of water.

**Riparian Buffer** – See Buffer definition.

**Sapling** – A young tree less than four inches (9.75 cm) in diameter (dbh) and less than 20 feet in height.

**Selected Clearing and Landscape Plan** – A site plan drawn to scale depicting the lot boundaries, shoreland protection district boundaries, shoreline, reference line, all impervious surfaces, structures, septic and well systems, setback requirements, proposed view corridor, and existing and proposed trees and vegetation.

**Setback** – Horizontal distance from the reference line of a water body to the nearest part of a structure, road, parking space or other regulated object or area.

**Shoreland** – The area of land adjacent to the reference line of a stream, river, pond, lake, bay, estuary, or other similar body of water.

**Shoreland Frontage** – The average of the distances of the actual natural shoreline frontage and a straight line drawn between the property lines (RSA 483-B:4, Definitions).

**Shoreline** – The intersection of a specified plane of water with the beach or bank. It migrates with changes of the water level.

**Shrub** – A woody perennial, smaller than a tree, usually branching from the base with several main stems.

**Stream Order** – A classification system for streams based on stream hierarchy. The smaller the stream, the lower its numerical classification. For example, a first order stream does not have tributaries and normally originates from springs or seeps. At the confluence of two first order streams, a second order stream begins and at the confluence of two second order streams, a third order stream begins, et.seq.

**[Margin Note: Stream ordering is a widely applied method for classifying streams. Its use in classification is based on the premise that the order number has some relationship to the size of the contributing area, to channel dimensions and to stream discharge (Strahler 1964). The most common method used in stream ordering is based on the Strahler Method. This method is applied by DES and GRANIT in classifying streams within the New Hampshire Hydrography Dataset.]**

**Stream or River** – A free-flowing body of water or segment or tributary of such water body (RSA 483:4, XVII.).

**Structure** – Anything built for the support, shelter or enclosure of persons, animals, goods or property of any kind, together with anything constructed or erected with a fixed location on or in the ground, exclusive of fences, and poles, wiring and other aerial equipment normally associated with service drops as well as guying and guy anchors. The term includes structures temporarily or permanently located, such as decks, patios, and satellite dishes.

**Stormwater or Surface Water Runoff** – Water that flows over the surface of the land as a result of rainfall or snow-melt. Surface water enters streams and rivers to become channelized stream flow.

**Stormwater Management Plan** – An analysis and plan designed in accordance with rules adopted by the DES under RSA 541-A for terrain alteration under RSA 485-A:17, to manage stormwater and control erosion and sediment, during and after construction.



**Surface Waters** – Those portions of waters of the state as defined by RSA 482-A:4, which have standing water or flowing water at or on the surface of the ground. This includes but is not limited to rivers, streams, lakes, ponds and tidal waters (Env-Wt 101.88).

**Timber Harvesting** – The cutting and removal of timber for the primary purpose of selling or processing forest products.

**Tree** – A woody perennial having a main stem.

**USGS (United States Geological Survey) topographic map** – A map that uses contour lines to represent the three-dimensional features of a landscape on a two-dimensional surface. Map scale – 1:24,000.

**Water Body** – Any pond, lake, river or stream.

**Water Dependent Use or Structure** – A use or structure that services and supports activities that require direct access to, or contact with the water, or both, as an operational necessity and that requires a permit under RSA 482-A, including but not limited to a dock, pier, breakwater, beach, boathouse, retaining wall, or launching ramp. Hydroelectric facilities, including, but not limited to, dams, dikes, penstocks, and powerhouses, shall be recognized as water dependent structures, however, these uses are exempt from the requirements of this Ordinance.

**Wetlands** – areas inundated or saturated by surface or ground water at a frequency and duration sufficient to support, and that under normal circumstances does support, a prevalence of vegetation typically adapted for life in saturated soil conditions. Wetlands generally include swamps, marshes, bogs, and similar areas (RSA 482-A:2).

## VII. SHORELAND PROTECTION DISTRICT REGULATIONS

**[Margin Note: The following shoreland protection regulations are modeled after specific provisions of the CSPA (RSA 483-B) as applicable, the recommendations contained within the Final Report of the Commission to Review the Effectiveness of the CSPA, as well as the DES Model Rule for the Protection of Water Supply Watersheds. Some noted key provisions include a 25-foot setback for primary structures from the reference line of first and second order streams, a 50-foot setback for all other water bodies, a maximum impervious surface requirement of 20 percent of the lot area located within the shoreland protection district, and Conditional Use requirements for water-dependent uses and structures. The riparian buffer requirements included within this ordinance are modeled after the three-stage riparian buffer design and buffer model ordinance favored by the journal *Watershed Protection Techniques* and developed by the Center for Watershed Protection, Elliot City, Maryland.]**

### a) Prohibited Water Pollution Hazards, Uses, Structures and Activities

The following uses, structures and activities are prohibited within the Shoreland Protection District:

1. Establishment or expansion of salt storage yards, automobile junk yards and solid or hazardous waste facilities.
2. Establishment or expansion, dry cleaning establishments and automobile service/repair shops.
3. Laundry/car wash establishments not on municipal or public sewer.
4. Subsurface disposal of pollutants from sewage treatment facilities, other than on-site septic systems.
5. Storage of hazardous substances, including the use of road salt, de-icing chemicals, herbicides, pesticides, or fertilizer, (except limestone) within 50 feet of the reference line of any property. Fifty feet beyond the reference line, low phosphate, slow release nitrogen fertilizer or limestone may be used on areas that are already vegetated.
6. Bulk or temporary storage of chemicals above or below ground.
7. Bulk or temporary storage of petroleum products or hazardous materials above or below ground, excluding normal residential or business use of liquid petroleum products and heating fuels for on-premise use.
8. Sand and gravel excavations as defined in RSA 155-E.
9. Mining or the processing of excavated materials.
10. Any use or activity not expressly permitted.

## Fertilizer and Pesticide Restrictions

- **No fertilizer or pesticide within 50 feet of the reference line.**
- **From 50 feet to 250 feet only low phosphate, slow release nitrogen**

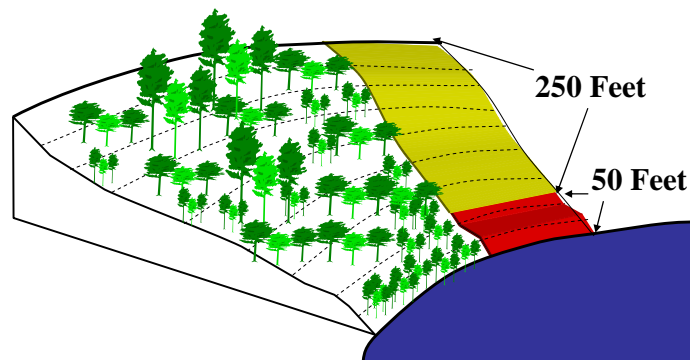

Source: N.H. Department of Environmental Services

### b) Permitted Uses, Structures and Activities

All necessary state and local approvals and permits shall be obtained prior to the commencement of any activity within the Shoreland Protection District.

The following uses, structures and activities are permitted within the Shoreland Protection District, subject to state and local approval:

1. All permitted uses allowed within the municipality's underlying zoning district(s), except those uses expressly prohibited as listed above.
2. All primary structures shall be setback a minimum distance of 25 feet from the reference line of all first and second order streams, 50 feet of all third order and higher streams, lakes, ponds, and coastal estuaries as required by the CSPA.
3. All accessory structures shall be setback a minimum distance of 25 feet from the reference line of all streams, lakes, ponds and coastal estuaries.
4. Water-dependent structures, or any part thereof, built over, on or within adjacent public waters subject to the jurisdiction of RSA 483-B 9.2c. shall be constructed only as approved by the DES, pursuant to RSA 482-A. All water-dependent uses or structures or parts thereof, built over, on or within the adjacent waters subject to this Ordinance shall be required to obtain a Conditional Use Permit from the planning board of the municipality in accordance with the requirements of subsection c) Conditional Uses below.
5. Other permitted uses within the Shoreland Protection District, subject to necessary local and state approval, include the following:
  - a. Public water supply facilities, including water supply intakes, pipes, water treatment facilities, pump stations and disinfectant stations.
  - b. Public water and sewage treatment facilities.
  - c. Hydroelectric facilities, including, but not limited to dams, dikes, penstocks and powerhouses.
  - d. Public utility lines and associated structures and facilities.
  - e. Existing solid waste facilities, including the construction of accessory structures and other activities consistent with the operation of the facility and its solid waste permit, including filling, grading and installing monitoring wells and other drainage structures.
  - f. Flood control structures.
  - g. Public roads and public access facilities, including boat ramps.

**c) Conditional Uses**

The following Conditional Uses are permitted within the Shoreland Protection District, subject to all applicable local, state and federal regulations:

1. Marinas developed in accordance with the following requirements:
  - a. Minimum shoreland frontage shall be 300 feet with an additional 25 feet of shoreland frontage per boat slip.
  - b. Off street parking shall be provided at a rate of 500 square feet per boat slip.
  - c. Submission of an environmental impact study including measures to mitigate potential negative impact on the adjacent waters, including but not limited to:
    - (1) Measures to prevent leakage or spills of fuels, lubricants, wastewater and other potential pollutants into the public waters.
    - (2) Assurances that impact on wetlands and other related sensitive areas have been avoided.
  - d. Submission of a site plan, that is consistent with local regulations, for review by the planning board, which includes locations of rest rooms, buildings, parking areas and all related support facilities with assurances that these facilities shall be permanently available to the project.
  - e. Receipt of a wetland permit from DES.

2. Water dependent uses and structures including, but not limited to, docks, wharves, boat ramps, etc. All water dependent uses and structures shall be approved as a Conditional Use Permit in accordance with the following requirements:
  - a. The use is in keeping with the purpose and intent of this Ordinance.
  - b. The least impacting route and methodology for the use have been selected as the best practicable alternative.
  - c. Canopies and seasonal covers extend only over the boat slips and shall be removed during the non boating season.

**d) Minimum Lot Requirements**

1. The minimum size for new lots in areas dependent upon on-site subsurface wastewater systems shall be determined by either the municipality's underlying zoning district requirements or the soil type lot size determinations, as established by the DES under RSA 485-A and rules adopted to implement it.
2. The total number of residential units in the protected shoreland district, whether built on individual lots or grouped as cluster or condominium development, shall not exceed:
  - a) One unit per 150 feet of shoreland frontage; or
  - b) For any lot that does not have direct frontage, one unit per 150 feet of lot width as measured parallel to the shoreland frontage that lies between the lot and the reference line.
3. The total constructed, impervious surface area within any lot shall not exceed 20 percent of the area of the lot located within the shoreland protection district. In instances when the existing tree cover has been depleted, 25 percent impervious coverage may be granted in exchange for additional native tree and shrub planting within 50 feet of the reference line. This should be enforced through a deed restriction whereby the property owner agrees not to cut after the trees are planted.

**e) Subsurface Wastewater Disposal Facilities**

1. All new lots, including those in excess of five acres, any portion of which is located within the Shoreland Protection District, shall require subdivision approval by the DES Water Division, Subsurface Systems Bureau pursuant to RSA 485-A:29. All subsurface wastewater disposal facilities shall be in compliance with RSA 485-A:29 and 483-B.

**g) Erosion and Siltation**

1. New structures and all modifications to existing structures within the Shoreland Protection District shall be designed, constructed and maintained to prevent the release of surface runoff across exposed mineral soils.
2. All earth moving or excavation activities on lots greater than 1 acre in size either partially or wholly within the Shoreland Protection District, including the construction of new structures and modifications to existing structures shall be conducted in accordance with a stormwater management plan approved by the municipality's planning board. Such plan shall be designed in accordance with rules adopted by the DES under RSA 541-A for terrain alteration under RSA 485-A:17, to manage stormwater and control erosion and sediment, during and after construction. All erosion control measures shall be implemented before any earth disturbance occurs.

3. In new developments, on-site and non-structural stormwater management alternatives shall be preferred over larger facilities within the riparian buffer.
4. When constructing stormwater management facilities, the area cleared shall be limited to the area required for construction, and adequate maintenance access only.
5. A permit under RSA 485-A:17, I. shall be required for developed, or subdivided land whenever there is a contiguous disturbed area exceeding 50,000 square feet that is either partially or wholly within the Shoreland Protection District.

**h) Riparian Buffer Requirements**

**[Margin Note: The riparian buffer standards included in this ordinance are based upon the Center for Watershed Protection’s Buffer Model Ordinance and as such these standards present the best technical guidance available to create and protect the most effective riparian buffers possible.**

**Also included are appropriate buffer standards from New Hampshire’s CSPA and the Commission’s recommendations where applicable. Municipalities should use these standards as a guide to adopt the most appropriate buffer requirements for their community considering such factors as existing site conditions, ease of enforcement, public acceptance, and the sensitivity and vulnerability of the water body to be regulated.**

**Municipalities are also encouraged to include a reference to these standards in their site plan and subdivision regulations and to add a checklist item or requirement that the location of all streams and water bodies be surveyed and accurately shown on site plans and subdivisions.]**

**Riparian Buffer.** Within the Shoreland Protection District, a riparian buffer of natural vegetation and trees shall be maintained or established within **75** feet of the reference line of all first and second order streams, and **150** feet of the reference line of all third and fourth and higher order streams, lakes, ponds and coastal estuaries. This riparian buffer is similar in terminology to the Natural Woodland Buffer under the CSPA.

To address areas containing steep slopes, the following formula recommended by the Center for Watershed Protection should be used to expand the riparian buffer widths as noted above:

Percent Slope*	Width of Buffer
15%-17%	add 10 feet
18%-20%	add 30 feet
21%-23%	add 50 feet
> 24%	add 60 feet

\*Percent slope shall be based on an average of the overall slope dividing the average vertical distance of the slope into the overall horizontal distance of the slope.

*Source: Southern New Hampshire Planning Commission.  
Adapted from Center for Watershed Protection*

Within the riparian buffer, the following management zones shall be maintained.

- 1. Waterfront Zone:** The waterfront zone is located closest to the water’s edge and serves to protect the physical and ecological integrity of the shoreland. This zone must be maintained

in a natural state although a view corridor and a maximum 6 feet wide path to the water's edge may be established in accordance with an approved Selected Clearing and Landscape Plan. This zone extends a minimum distance of **25** feet from the reference line for 1<sup>st</sup> and 2<sup>nd</sup> order streams and a minimum distance of **50** feet from the reference line for all other water bodies. Allowable uses within the waterfront zone are restricted to flood control structures, utility rights of way, footpaths, road crossings such as bridges and culverts as required and water-dependent structures and uses where permitted under Section VII. b. and c. of this ordinance. Target sediment and pollutant removal rates are to be within 50 percent and 60 percent.

**[Margin Note: A minimum fixed buffer width of 10 meters or 33 feet is documented in the scientific literature as providing approximately 60 percent or greater sediment and pollutant removal while minimally protecting the adjacent water body (Source: Desbonnet et al. 1994 and Center for Watershed Protection).]**

Within the Waterfront Zone, the following additional prohibitions and limitations apply:

- a. No mechanized logging, no clear cutting of trees, and no cutting or removal of vegetation and natural ground cover (including the duff layer) below 3 feet in height shall be permitted, except as provided by an approved Selected Clearing and Landscape Plan.
  - b. Restricted tree care involving the removal of dead, diseased, unsafe, or fallen trees, saplings, shrubs is permitted. All stumps and their root systems, stones, and duff shall be left intact in or on the ground.
  - c. A view corridor and path to the water's edge may be established in accordance with a **Selected Clearing and Landscape Plan** submitted to and approved by the planning board of the municipality.<sup>2</sup> This plan shall include photographic documentation of the pre-existing riparian buffer. The view corridor shall not exceed 75 feet in width or one-third the width of the shoreline frontage, whichever is less. View corridors must also be in compliance with the CSPA, Natural Woodland Buffer requirements, RSA 483-B.
  - d. Preservation of dead and living trees that provide dens and nesting places for wildlife is encouraged.
  - e. Planting and reforestation efforts to restore native vegetation within this zone is encouraged.
2. **Middle Zone:** The middle zone begins at the outer edge of the waterfront zone extending out a minimum fixed distance of **25** feet for 1<sup>st</sup> and 2<sup>nd</sup> order streams and a minimum distance of **50** feet for all other water bodies. The overall width of the middle zone can vary depending upon stream order and slope. Target sediment and pollutant removal rates are to be within 60 to 70 percent. Forest management and limited tree clearing and removal are allowed within the middle zone as well as limited recreational uses, stormwater BMPs, paths, and other similar uses as permitted under Section VII. b. and c. of this ordinance. However, a minimum of 50 percent of the tree canopy within this zone shall remain in an undisturbed state. Overall tree canopy shall be managed through a Selective Clearing and Landscape Plan.

---

<sup>2</sup> An example of a Selective Clearing and Landscape Plan can be found in Randolph, 2004, Figure 14.3, pg. 446.

**[Margin Note: A minimum fixed buffer width of 15 meters or 50 feet is documented in the scientific literature as providing greater than 60 percent sediment and pollutant removal while providing minimal general wildlife and avian habitat value. (Center for Watershed Protection).]**

Within the middle zone, the following additional prohibitions and limitations apply:

- a. Impervious surfaces on the portion of the lot within the shoreland protection district shall be limited to 20 percent subject to Section D. 3. of this ordinance.
  - b. No mechanized logging or clear cutting of trees and vegetation shall be permitted.
  - c. Limited tree removal and clearing, tree pruning, including the removal of dead, diseased, unsafe, or fallen trees, saplings, shrubs is permitted. All stumps and their root systems shall be left intact in the ground.
  - d. Fifty percent of this zone should remain in an undisturbed state.
  - e. A view corridor and path to the water's edge may be established in accordance with a **Selected Clearing and Landscape Plan** approved by the planning board of the municipality. No more than 50 percent of the tree canopy within this zone may be removed as shown on the **Selected Clearing and Landscape Plan**.
  - f. Preservation of dead and living trees that provide dens and nesting places for wildlife is encouraged.
  - g. Planting and reforestation efforts to restore the native vegetation within this zone is encouraged.
3. **Outer Zone:** The function of the outer zone is to prevent encroachment into the inner and middle zones of the riparian buffer and to filter runoff from adjacent residential and commercial development. The outer zone begins at the outer edge of the middle zone extending out a minimum distance of **25** feet for 1<sup>st</sup> and 2<sup>nd</sup> order streams and a minimum distance of **50** feet for all other water bodies. Target sediment and pollutant removal rates are to be within 70 to 90 percent.

**[Margin Note: A minimum fixed buffer width of 20 meters or 66 feet is documented in the scientific literature as providing 70 percent or greater sediment and pollutant removal while providing minimal general wildlife and avian habitat value. (Source: Desbonnet et al. 1994 and Center for Watershed Protection).]**

Within the outer zone, the following additional prohibitions and limitations apply:

- a. Tree removal and clearing, tree pruning, including the removal of dead, diseased, unsafe, or fallen trees, saplings, shrubs is permitted in accordance with a **Selected Clearing and Landscape Plan** approved by the planning board of the municipality.
- b. No more than 50 percent of the tree canopy within this zone may be removed as shown on the **Selected Clearing and Landscape Plan**.
- c. Preservation of dead and living trees that provide dens and nesting places for wildlife is encouraged.
- d. Planting and reforestation efforts to restore the natural vegetation within this zone is encouraged.
- e. Impervious surfaces on the portion of the lot within the shoreland protection district shall be limited to 20 percent subject to Section D. 3. of this ordinance.

## VIII. NON CONFORMING LOTS, USES AND STRUCTURES

- a) **General Purpose:** It is the intent of this Ordinance to promote the conforming use of land located within the Shoreland Protection District, except that non-conforming lots, structures and uses that existed before the effective date of this Ordinance or amendments thereto shall be allowed to continue, subject to the requirements as set forth in this section. Except as otherwise provided in this Ordinance, a non-conforming lot, use or structure shall not be permitted to become more non-conforming.
- b) **Non-conforming Lots:** Non-conforming, undeveloped lots of record that are located within the Shoreland Protection District shall comply with the following restrictions, in addition to any other requirements of the municipality's zoning ordinance:
  - 1. Except when otherwise prohibited by law, present and successive owners of an individual undeveloped lot may construct building or structure on it, notwithstanding the provisions of this Ordinance.
  - 2. Conditions may be imposed which, in the opinion of the municipality's Zoning Board of Adjustment as appropriate, more nearly meet the intent of this Ordinance, while still accommodating the applicant's rights.
  - 3. Building on non-conforming lots of record also include but not limited to docks, piers, boathouses, boat loading ramps, walkways, and other water dependent structures, consistent with this Ordinance.
- c) **Non-conforming Uses:** Existing uses that are non-conforming under this ordinance may continue until the use ceases to exist or the use is discontinued for a period of one year. An existing non-conforming use may not be changed to another non-conforming use; existing non-conforming uses shall be required to meet the requirements of this ordinance to the maximum extent possible.
- d) **Non-conforming Structures:** Except as otherwise prohibited, non-conforming structures, erected prior to the effective date of this Ordinance or amendments thereto, located within the Shoreland Protection District may be repaired, renovated, or replaced in kind using modern technologies, provided the result is a functionally equivalent use. Such repair or replacement may alter the interior design or existing foundation, but no expansion of the existing footprint or outside dimensions shall be permitted. An expansion that increases the sewage load to an on-site septic system, or changes or expands the use of a septic system or converts a structure to condominiums or any other project identified under RSA 485-A:29-44 and rules adopted to implement it shall require DES approval. Between the primary building line and the reference line as shown on the following figure, no alteration shall extend the structure closer to the adjacent water body, except that the addition of a deck is permitted up to a maximum of 12 feet towards the reference line.

## IX. RIPARIAN BUFFER MANAGEMENT, MAINTENANCE AND INSPECTION.

- a) It shall be the responsibility of every property owner within the Shoreland Protection District to manage and maintain the vegetation and natural conditions existing within the riparian buffer located on their property. Management includes specific limitations on the alteration of the natural conditions of these resources as specified by this Ordinance. To help property owners



assume this responsibility, it shall be the duty of every property owner to secure and install markers every 50 feet on trees depicting the location of the riparian buffer on their property.

**[Margin Note: These buffer markers should be designed and sold by the conservation commission of the municipality to property owners. Examples of tree markers can be obtained from the Town of Bow, N.H. Installation and cost of the markers should be the responsibility of the property owner.]**

- b) It shall be the responsibility of the planning board of the municipality to ensure that all plats and rights of way, prepared for recording, and site plans adopted by the planning board clearly:
  - 1. Show the extent of the riparian buffer on the subject property by metes and bounds.
  - 2. Label the riparian buffer, building setbacks, and the waterfront, middle and outer zones of the riparian buffer.
  - 3. Provide a note to reference the riparian buffer stating: “There shall be no clearing, grading, construction or disturbance of vegetation except as permitted by the planning board of the municipality.”
  - 4. provide a note to reference any protective covenants governing the riparian buffer area stating: “Any riparian buffer shown hereon is subject to protective covenants which may be found in the land records and which restrict disturbance and use of these areas.”
- c) It shall be the responsibility of the planning board of the municipality through aerial photography to inspect the integrity of the riparian buffer both annually and immediately following severe storms for evidence of sediment deposition, erosion, or concentrated flow channels and corrective actions taken to ensure the integrity and functions of the riparian buffer.

**[Margin Note: Procedures for conducting these inspections should be developed by the planning board and the municipality. This should also include obtaining photographic documentation of the integrity of the riparian buffer as part of the review and approval of stormwater management or selective clearing and landscape plans.]**

## **X. EXCEPTIONS**

The following land uses are exempt from the provisions of this Ordinance:

- a) Forest management not associated with shoreland development or land conversion, and conducted in compliance with RSA 227-J:9.
- b) Forestry involving water supply reservoir watershed management.
- c) Agriculture activities and operations as defined in RSA 21:34-a. (except animal feedlots) provided such activities and operations are conducted in accordance with best management practices.
- d) Temporary stream, stream bank, and other vegetation restoration projects, the goal of which is to restore the shoreline and riparian buffer to an ecologically healthy state.
- e) Wildlife and fisheries management activities consistent with the State Wildlife Action Plan and applicable state laws.
- f) The creation of foot path(s) to the water in accordance with an approved selective clearing and landscape plan and the construction of perched sandy beaches in accordance with a wetland permit issued by DES.
- g) Other uses permitted by the DES or under Section 404 of the Clean Water Act.  
Notwithstanding the above, all except uses, structures or activities shall comply with all applicable best management practices and shall not diminish water quality as defined by the

Clean Water Act. All excepted uses shall be located as far from the reference line as reasonably possible.

## **SUMMARY OF MODEL ORDINANCE SHORELAND PROTECTION DISTRICT AND RIPARIAN BUFFER STANDARDS**

### **SHORELAND PROTECTION DISTRICT**

- **150** feet for 1<sup>st</sup> and 2<sup>nd</sup> order streams and **250** feet for all other water bodies.
- Establishment/expansion of salt storage yards, auto junk yards, solid waste and hazardous waste facilities, animal feedlot operations, dry cleaning establishments, automobile service/repair shops, laundry/car wash establishments not on municipal water or sewer, disposal or land application of biosolids, including septage, sewage sludge and animal manure are prohibited.
- Subsurface disposal of pollutants from sewage treatment facilities, other than on-site septic systems, storage or hazardous substances, including the use of road salt and de-icing chemicals are prohibited.
- Bulk or temporary storage of chemicals above or below ground, bulk or temporary storage of petroleum products or hazardous materials above or below ground, excluding normal residential or business use of liquid petroleum products and heating fuels for on-premise use are prohibited.
- Sand and gravel excavations as defined in RSA 155-E, mining or the processing of excavated materials, and any other use or activity not expressly permitted.
- No fertilizer, except limestone between the reference line and 50 feet. From 50 feet landward of the reference line to 250 feet only low phosphate, slow release nitrogen fertilizer may be used.

#### **Impervious Surface Area Limitations:**

- Total constructed, impervious surface area is limited to 20percent of a lot either partially or wholly located within the shoreland protection district. This may be increased to 25 percent in exchange for additional native tree and shrub planting within 50 feet of the reference line through a deed restriction.

#### **Stormwater Management:**

- All earth moving or excavation activities on lots greater than 1 acre in size either partially or wholly within the shoreland protection district, including the construction of new structures and modifications to existing structures must be conducted in accordance with an approved stormwater management plan per NHDES specifications under RSA 541-A for terrain alteration and RSA 485-A:17 to manage stormwater and control erosion and sediment, during and after construction.
- A permit is also required under RSA 485-A:17, I. for developed, or subdivided land whenever there is a contiguous disturbed area exceeding 50,000 square feet that is partially or wholly within the shoreland protection district.

### **RIPARIAN BUFFER STANDARDS:**

- **Waterfront Zone:** 25 feet from reference line for 1<sup>st</sup> and 2<sup>nd</sup> order streams and 50 feet for all other water bodies. The Waterfront Buffer must be maintained in a natural state, although a view corridor and path to the water's edge may be established in accord with an approved plan.
- **Clearing and Landscape Plan.** No mechanized logging, no clear cutting of trees, and no cutting or removal of vegetation and natural ground cover (including the duff layer) below 3 feet in height is allowed, except as provided by this plan. Restricted tree care involving the removal of dead, diseased, unsafe, or fallen trees, saplings, shrubs is permitted. All stumps and their root systems, stones and duff shall be left intact in or on the ground.
- **Middle Zone:** 25 feet from the edge of the waterfront zone for 1<sup>st</sup> and 2<sup>nd</sup> order streams and 50 feet for all other water bodies. Forest management and limited tree clearing and removal are allowed. No more than 50 percent of the tree canopy within this zone can be removed. Overall tree coverage is managed through a Selected Clearing and Landscape Plan.
- **Outer Zone:** 25 feet from the edge of the middle zone for 1<sup>st</sup> and 2<sup>nd</sup> order streams and 50 feet for all other water bodies. No more than 50 percent of the tree canopy within this zone may be removed. Tree removal and clearing, tree pruning, including the removal of dead, diseased, unsafe, or fallen trees, saplings, shrubs is permitted.
- **Selected Clearing and Landscape Plan:** This plan is required in order to establish a view corridor and path to the water's edge as well as document the pre-existing riparian buffer conditions on the lot. The view corridor not exceed 75 feet in width or one-third the width of the shoreline frontage, whichever is less. View corridors must also be in compliance with the CSPA, Natural Woodland Buffer requirements per RSA 483-B.

---

#### **PRIMARY BUILDING LINE:**

- Primary structures must be set back at least **25** feet from the reference line for 1<sup>st</sup> and 2<sup>nd</sup> order streams and **50** feet

for all other water bodies.

---

## ACCESSORY STRUCTURES

- Accessory structures must be setback at least **25** feet from the reference line.

---

## REFERENCE LINE

- For coastal waters = highest observable tide line
- For rivers = ordinary high water mark
- For natural fresh water bodies = natural mean high water level
- For artificially impounded fresh water bodies – water line at full pond

## Ordinance References

Alliance for Chesapeake Bay, *Riparian Forest Buffer*, white paper, January 1996.

Center for Watershed Protection, Stormwater Center, Buffer Model Ordinance, [www.stormwatercenter.net/Model%20Ordinances/buffer\\_model\\_ordinance.htm](http://www.stormwatercenter.net/Model%20Ordinances/buffer_model_ordinance.htm).

Chase, Vicki, Laura Deming, and Francesca Latawiec, *Buffers for Wetlands and Surface Waters, A Guidebook for New Hampshire Municipalities*, Audubon Society of New Hampshire and NH Office of State Planning, November 1995, Revised May 1997.

Deacon, Jeffrey R., Sally A. Soule and Thor E. Smith, *Effects of Urbanization on Stream Quality at Selected Sites in the Seacoast Region in New Hampshire, 2001-03*. Scientific Investigations Report 2005-5103, U.S. Department of Interior and New Hampshire Department of Environmental Services, USGS, Reston, Virginia 2005.

Magee, J., *Value of Riparian Buffers*, New Hampshire Fish and Game Department, February 2007.

Maine Department of Environmental Protection, *Chapter 1000: Guidelines for Municipal Shoreland Zoning Ordinances*, June 1996.

NH Department of Environmental Services, *Final Report of the Commission to Review the Effectiveness of the Comprehensive Shoreland Protection Act*, November 30, 2006. [www.des.nh.gov/cspa/CSPACommissionReport/](http://www.des.nh.gov/cspa/CSPACommissionReport/).

NH State Conservation Committee, *Riparian Conservation: A Professional's Practical Guide to Financial Assistance and Program Support*, March 22, 2001.

Randolph, J., *Environmental Land Use Planning and Management*, Island Press, 2004.

RSA 483-B, State of New Hampshire Comprehensive Shoreland Protection Act (CSPA).

Schueler, T.R., *Site Planning for Urban Stream Protection*. Center for Watershed Protection, Silver Springs, MD, 1995.

Southern NH Planning Commission, *Outreach Program to Develop and Implement Local Land Use Regulations to Protect the Remaining Undisturbed Natural Shoreland Buffers in the Towns of Candia and Deerfield, NH*, Final Report, December 2006.

Strahler, A.N. "Quantitative geomorphology of drainage basins and channel networks," pp. 4-39 to 4-76, in Chow, ed., *Handbook of Applied Hydrology*, McGraw-Hill, New York, 1964.

Tjaden, Robert L. and Glenda M. Weber, *Riparian Buffer Management: Riparian Buffer Design, Establishment, and Maintenance*, Maryland Cooperative Extension, Fact Sheet 725.

Town of Antrim, New Hampshire, Article XI-A, Shoreland Protection District.

University of New Hampshire Cooperative Extension, *Guide to New Hampshire Timber Harvesting Laws*, August 2004.

US EPA, *Riparian Buffer Width, Vegetative Cover, and Nitrogen Removal Effectiveness: A Review of Current Science and Regulations*, October 2005.

**Ossipee Watershed Coalition**  
**Natural Resource Planning Guide**  
**Chapter V- A.4 Surface Water Resources: Rivers and Streams**

**I. Introduction to the Importance of the Watershed's rivers and streams**

Waters from rain and snowmelt follow downhill courses over and through a watershed's terrain. Due to water's ability to act as a nearly universal solvent, chemical conditions within such water flows are a product of all they come in contact with crossing a region – collecting and transporting both helpful nutrients and debilitating contaminants. Eventually, in most cases, runoff water gathers in small brooks that are joined by other such flows to form larger streams that serve as inlet water sources for lakes and ponds, or that coalesce with other streams to become wider and more substantial rivers heading toward the sea. Beyond providing critical habitat for a diverse flora and fauna specifically adapted for living in flowing water, inlet streams also provide a vital source of replenishment for lake and pond waters lost to evaporation, seepage, or outlet losses, as well as for nutrients needed to fuel a lake's productivity.

Riparian vegetation includes stream-side plants that line such water flows. Dense, diverse riparian plants play a key role in protecting streams and rivers by modulating excessive water flowage and filtering out sediments and undesirable chemicals before they are allowed to enter. In addition, canopy shading of flowing waters keeps water temperatures cool – a condition required by trout and other "higher quality" biota, while lower vegetation supply streamside habitat for a variety of aquatic and semiaquatic animals.

Along with lakes and ponds, residents and visitors to the region find that the watershed's many rivers and streams provide a myriad of opportunities for boating, fishing, wildlife observation, and aesthetic appreciation.

**II. Description of the Resource**

**A. Distribution of Rivers and Streams within the Watershed**

The Ossipee Watershed is fortunate to include many streams and rivers, including the major ones listed in Table 1.

**Chapter V-A.4 Table 1: Distribution of Rivers and Streams within the Ossipee Watershed**

<b>Town</b>	<b>Named Moving Water Systems</b>
<b>Effingham</b>	Flanders Brook, Hodgedon Brook, Leavitt Brook, Mastin Brook, Phillips Brook, Pine River, Red Brook (#2), Wilkinson Brook, South River, Ossipee River
<b>Freedom</b>	Bennett Brook, Blaisdell Brook, Cold Brook, Lovering Brook, Moulton Brook, Nason Brook, Ossipee River, Shawtown Brook, Square Brook, Stony Brook, West Branch River
<b>Madison</b>	Blaisdell Brook, Cook's Brook, Deer River, Ferrin Brook, Forrest Brook, Frost Brook, Ham Brook, Salter Brook, West Branch
<b>Ossipee</b>	Badge Brook, Bearcamp River, Beech River, Canaan Brook, Chocorua River, Dan Hole River, Folsom Brook, Frenchman Brook, Gile Brook, Lovell River, Peavey Brook, Pike Brook, Pine Brook, Pine River, Poland Brook, Red Brook (#1), Stony Brook (#2), Sumner Brook, West Branch, White Brook, Youngs Brook
<b>Sandwich</b>	Arwood Brook, Captain Neal Brook, Cold River, Heath Brook, Pond Brook, Tewksberry Brook, Tilton Brook, White Brook, Whiteface River
<b>Tamworth</b>	Bearcamp River, Blasde Brook, Bryant Brook, Chocorua River, Claybank Brook, Cold Brook (#2), Deer Brook, Durrell Brook, Hoag Brook, Lord Brook, Meadow Brook, Meadow Brook (#2), Mill Brook, Paugus Brook, Sanborn Brook, Sanger Brook, Stony Brook, Swift River (#2), Tewksberry Brook, Whitiin Brook, Wonalancet River

## **B. River Monitoring**

### **1. Water Quality Monitoring of Rivers & Streams**

Refer to introductory information regarding the Water Quality Monitoring in the Ossipee Watershed in Chapter V-A.1. In 2002, GMCG established a three-part, long-term monitoring program to track water quality in streams and rivers of the Ossipee Watershed. The Regional Interstate Volunteers for the Ecosystems and Rivers of Saco (RIVERS) program is managed in conjunction with the University of New Hampshire and the Saco River Corridor Commission in Maine. River and stream monitoring has expanded to include the Ossipee Lake and Tributaries (OLT) program and the Volunteer Biomonitoring Assessment Program (VBAP) in recent years. Currently, 19 river sites (RIVERS program, Fig. 1), 11 major tributaries of Ossipee Lake (OLT program, Fig. 2), and 11 macroinvertebrate sampling sites (VBAP program, Fig. 3) are monitored within the watershed.

A total of 19 physical and chemical parameters are measured at testing sites, in addition to biological assessments of eleven sites. The program has also been extended from the summer months to include year-round sampling at seven sites. To accomplish this work, the program has also increased from fifteen to fifty volunteers, in addition to hundreds of summer campers and school children each year. The links below provide maps of testing sites, raw data, site photos, and site descriptions.

### **2. Sites & Site Maps**

RIVERS Program: [www.gmcg.org/administration/pdf/GMCG-2006-Rivers-Sites.html](http://www.gmcg.org/administration/pdf/GMCG-2006-Rivers-Sites.html)

Ossipee Lake & Tributaries Program: [www.gmcg.org/administration/pdf/GMCG-2006-OLT-Sites.html](http://www.gmcg.org/administration/pdf/GMCG-2006-OLT-Sites.html)

### **3. Water Quality Reports for Rivers & Streams of the Ossipee Watershed**

[2002 WQM Report: www.gmcg.org/wqm-report/2002-wqm-report.html](http://www.gmcg.org/wqm-report/2002-wqm-report.html)

[2003 WQM Report: www.gmcg.org/administration/pdf/2003\\_RIVERS\\_report.pdf](http://www.gmcg.org/administration/pdf/2003_RIVERS_report.pdf)

[2004 WQM Report: www.gmcg.org/administration/pdf/2004\\_WQM\\_report.pdf](http://www.gmcg.org/administration/pdf/2004_WQM_report.pdf)

[2006 VBAP Report: www.gmcg.org/administration/pdf/2006\\_annual\\_report\\_final\\_20061218.pdf](http://www.gmcg.org/administration/pdf/2006_annual_report_final_20061218.pdf)

[2007 WQM Report: www.gmcg.org/administration/pdf/2007WQMReport.pdf](http://www.gmcg.org/administration/pdf/2007WQMReport.pdf)

Data collected through the RIVERS, OLT and VBAP programs are used by the NH Department of Environmental Services in the Environmental Monitoring Database and examined biennially as part of the Environmental Protection Agency's surface waters assessment, as mandated by the Clean Water Act. These agencies do not even begin statistical analysis until after ten consecutive years of data has been collected. Sites are also compared to one another within the watershed, and assessed in light of acceptable surface water quality standards for the state or the state mean value for measured parameters. Water Quality Reports have been completed and given to watershed towns since 2002.

The first few years of monitoring water quality has shown that some sites experience elevated levels of calcium (Ca), sodium (Na), chloride (Cl), and/or nutrients such as nitrogen (N), phosphate (PO<sub>4</sub>), total phosphorus, dissolved organic carbon (DOC) or dissolved organic nitrogen (DON); or of low levels of dissolved oxygen (DO) and/or pH. Elevated silica (SiO<sub>2</sub>) is sometimes noted. In general, higher DOC levels are often associated with the influence of wetlands organic productivity – often accompanied by lower DO and (more acidic) pH. Wetlands are also often the source of humic-rich, tea-stain colored waters and of high concentrations of DOC and DON. Higher concentrations of Na and Cl usually relate to the application of road salt in winter. Since local groundwater is much higher in SiO<sub>2</sub> than are typical surface waters or rainfall, elevated SiO<sub>2</sub> levels usually occur during drier periods when ground water influence is strongest. Warmer temperatures (often associated with lower DO levels) and higher turbidity (water murkiness) are often the result of impoundments or lakes located upstream of the sampling site. A tighter canopy of trees overhead and the absence of open spaces such as impoundments usually results in lower than average temperatures.

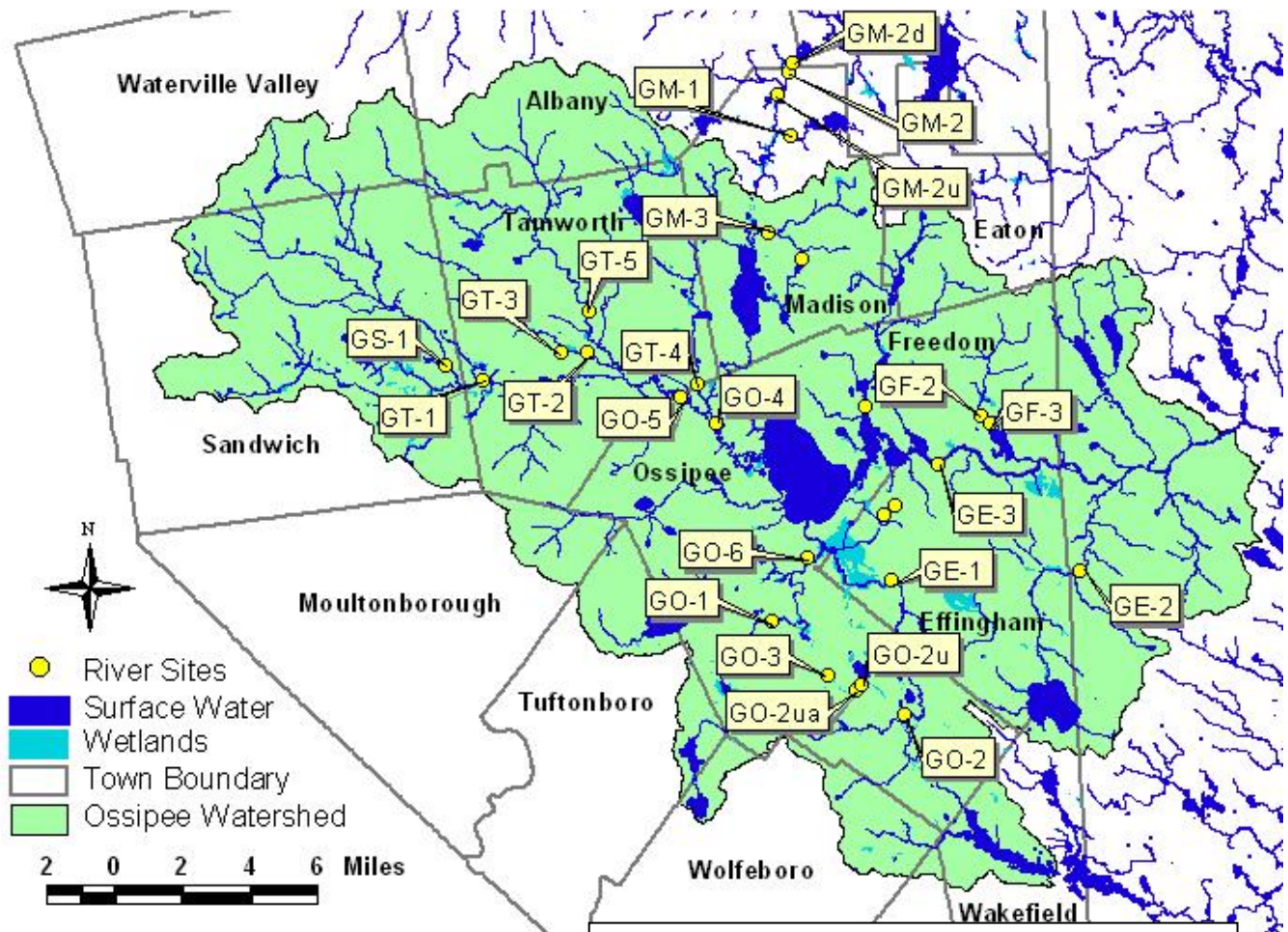

**Chapter V-A.4, Figure 1:** Ossipee Watershed Regional Interstate Volunteers for the Ecosystems and Rivers of the Saco (RIVERS) Program test sites. At these sites, GMCG staff and volunteers collected water samples.

Site ID	Waterbody	Town
GE-1	Pine River	Effingham
GE-2	South River	Effingham
GE-3	Ossipee River	Effingham
GF-1	Danforth outlet	Freedom
GF-2	Cold Brook	Freedom
GF-3	Cold Brook	Freedom
GM-1	Banfield Brook	Madison
GM-2	Pequawket Brook	Madison
GM-3	Forrest Brook	Madison
GT-1	Bearcamp River	Tamworth
GT-2	Mill Brook	Tamworth
GT-3	Mill Brook	Tamworth
GT-4	Chocorua River	Tamworth
GO-1	Beech River	Ossipee
GO-2	Frenchmans Brook	Ossipee
GO-3	Frenchmans Brook	Ossipee
GO-4	Bearcamp River	Ossipee
GO-5	Bearcamp River	Ossipee
GS-1	Cold River	Sandwich
GE-4	Red Brook	Effingham
GT-5	Swift River	Tamworth
GO-6	Beech River	Ossipee
GO-2ua	Frenchmans Brook	Ossipee
GO-2u	Frenchmans Brook	Ossipee
GM-2d	Pequawket Brook	Albany
GM-2u	Pequawket Brook	Madison

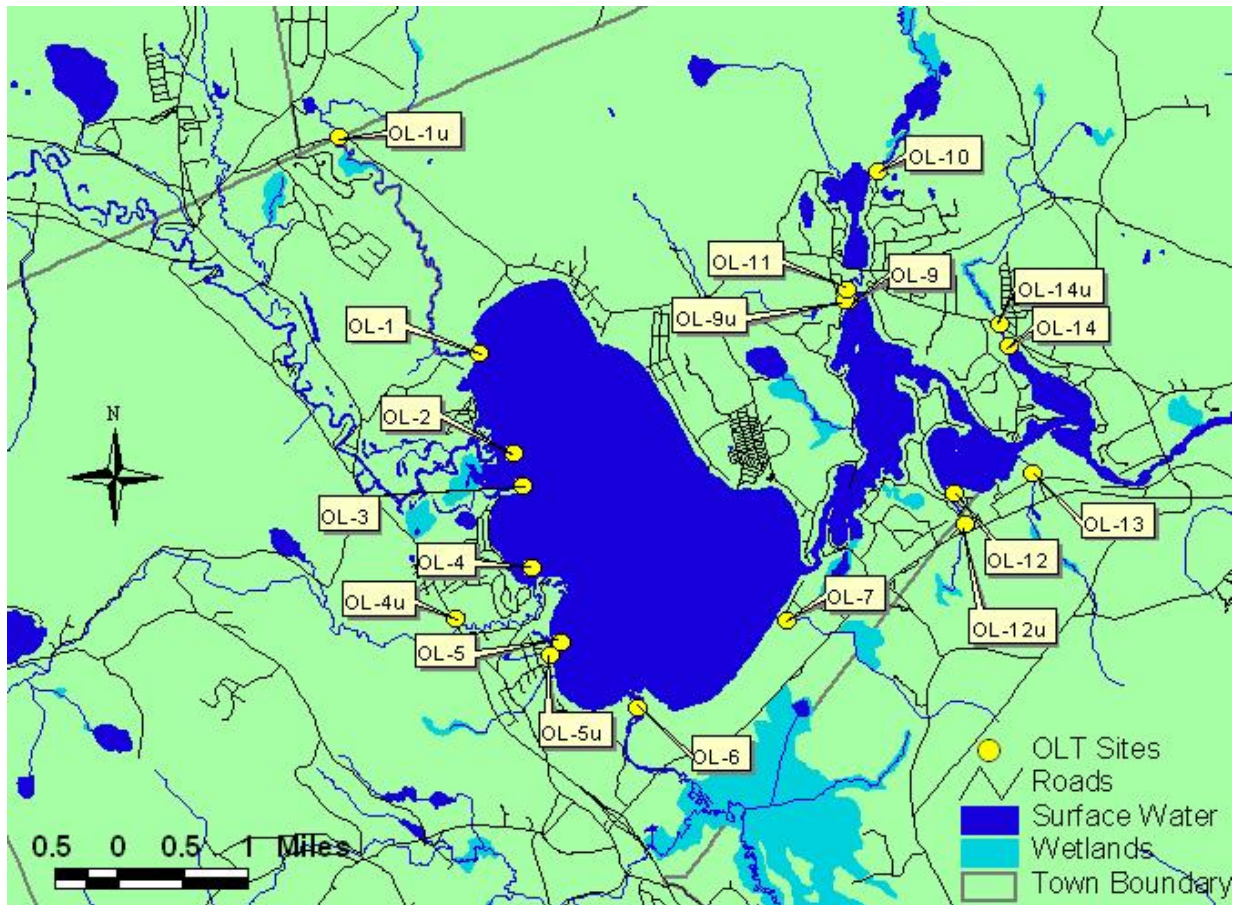

**Chapter V-A.4, Figure 2:**  
 Ossipee Lake Tributaries (OLT) program test sites. At these sites, GMCG staff and volunteers collected water samples and conducted field measurements to assess the chemical and physical health of waterbodies.

Site ID	Waterbody	Town
OL-1	West Branch	Ossipee
OL-1u	West Branch upstream	Ossipee
OL-2	Bearcamp River	Ossipee
OL-3	Patch Pond	Ossipee
OL-4	Lovell River	Ossipee
OL-4u	Lovell River upstream	Ossipee
OL-5	Weetamoe Inlet	Ossipee
OL-5u	Weetamoe Brook upstream	Ossipee
OL-6	Pine River	Ossipee
OL-7	Red Brook	Ossipee
OL-9	Cold Brook	Freedom
OL-9u	Cold Brook upstream	Freedom
OL-10	Danforth Inlet	Freedom
OL-11	Danforth Brook/Huckins	Freedom
OL-12	Phillips Brook	Effingham
OL-12u	Phillips Brook upstream	Effingham
OL-13	Leavitt/Camp Marist	Effingham
OL-14	Square Brook	Freedom
OL-14u	Square Brook upstream	Freedom

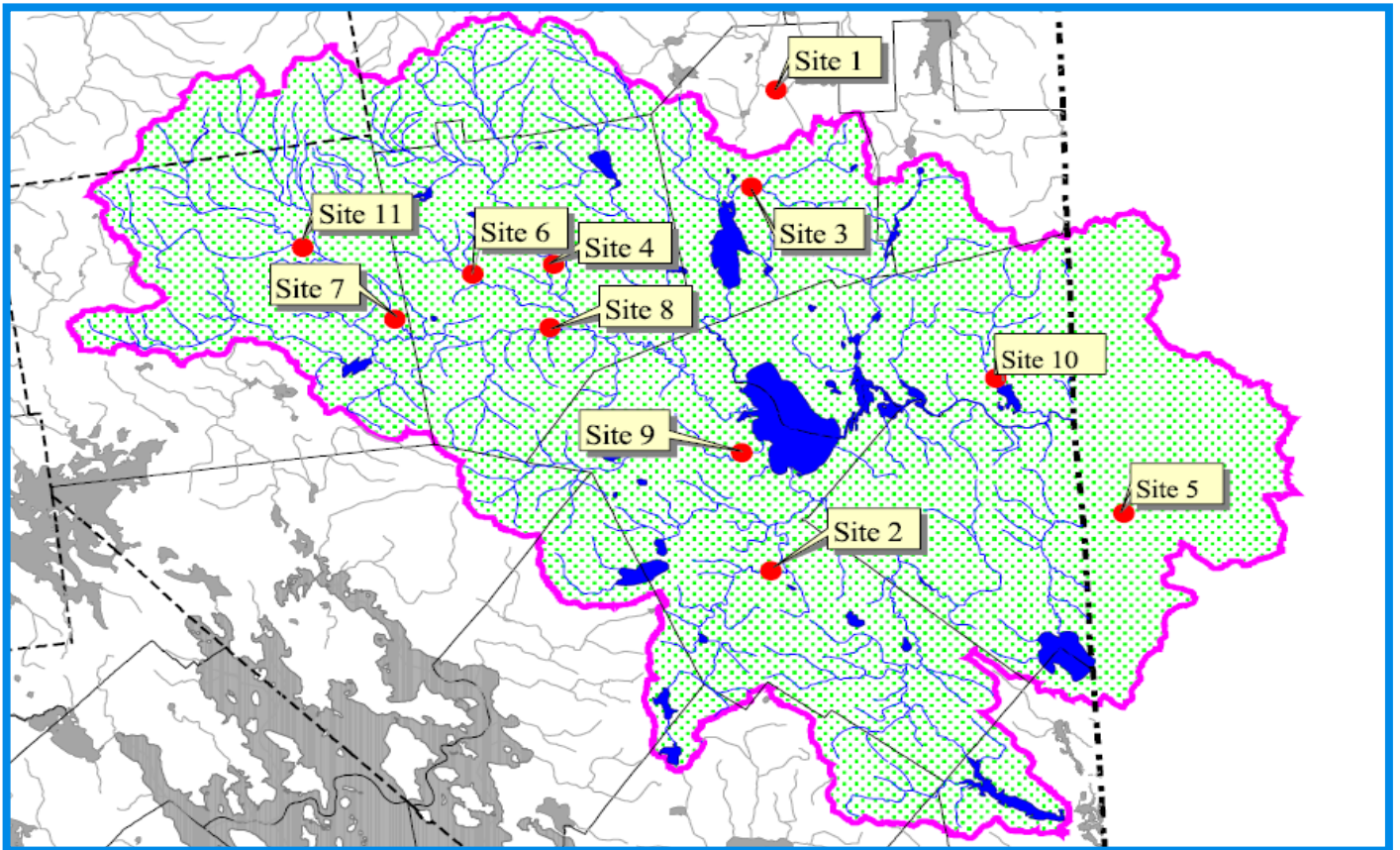

**Chapter V-A.4, Figure 3:**  
 Volunteers for Biomonitoring Assessment Program (VBAP) test sites. At these sites, DES and GMCG staff and volunteers collected, identified, and tallied macroinvertebrate samples to assess the biological health of various waterbodies

Site number	Stream name, town
1	Banfield Brook, Madison
2	Beech River, Ossipee
3	Forrest Brook, Madison
4	Swift River, Tamworth
5	South River, Parsonsfield
6	Mill Brook, Tamworth
7	Cold River, Sandwich
8	Bearcamp River, Tamworth
9	Lovell River, Ossipee
10	Cold Brook, Freedom
11	Pond Brook, Sandwich



Figure 4 illustrates one example of how river monitoring data, in this case for conductivity, can help communities track water quality over time and locate potential problems. Conductivity is the numerical expression of water's ability to carry an electrical current. Water contains ions or charged particles, such as chloride, nitrate, sulfate, phosphate, sodium, magnesium, calcium, iron and aluminum. High conductivity levels can be a sign of pollution from road salting, septic systems, wastewater treatment plants and urban or agricultural runoff. According to the DES, New Hampshire's surface waters traditionally have low conductivity values, but levels are increasing at a statistically significant rate due to the influence of road salting, faulty septic systems and urban and agricultural runoff. Conductivity testing and bracketing of rivers can help communities locate areas and road locations where these sources may be impacting water quality (Figure 1).

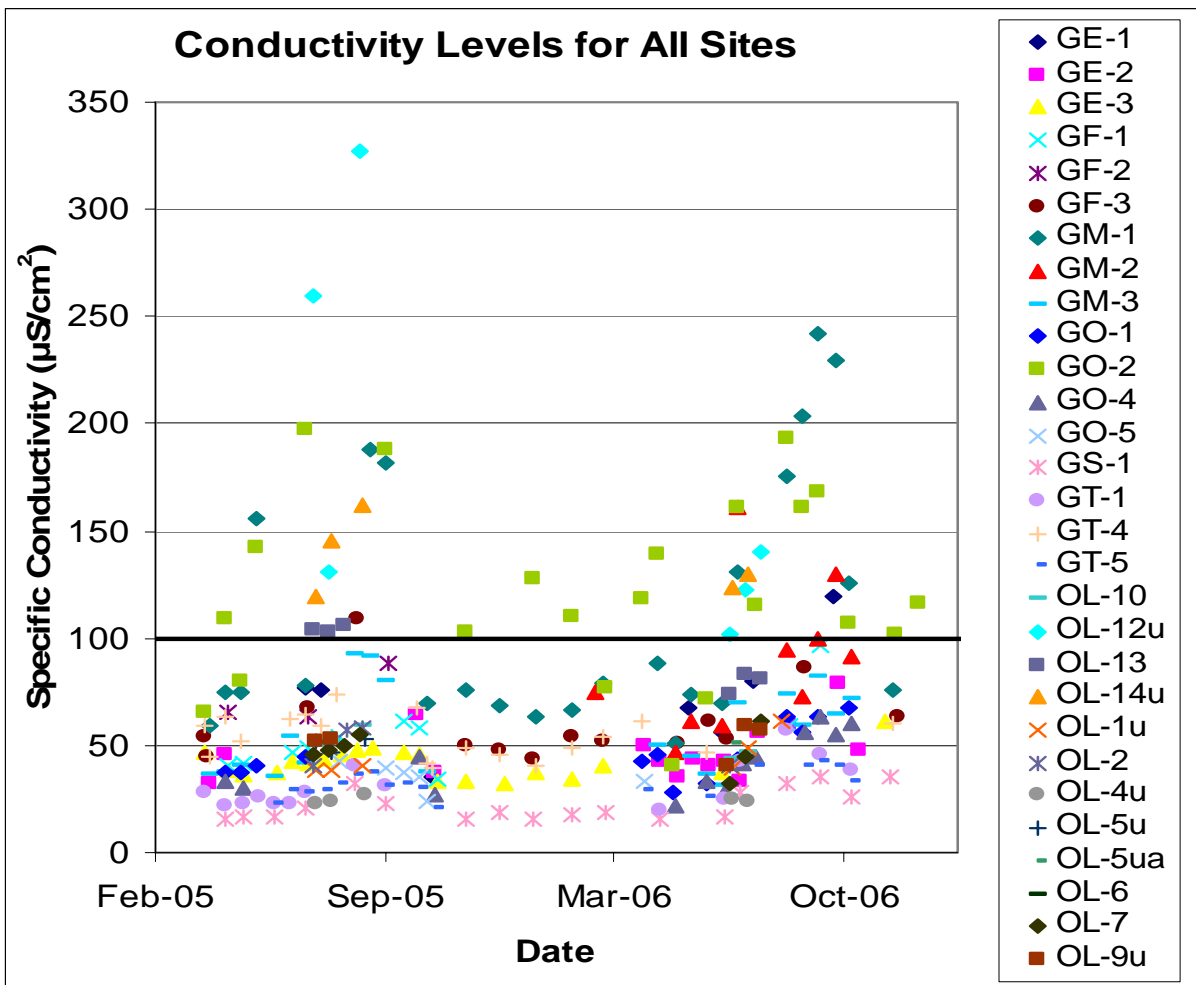

**Chapter V-A.4, Figure 4: Water Quality Trends.** Conductivity levels greater than  $100 \mu\text{S}/\text{cm}^2$  have been observed at some sites within the watershed since conductivity testing began in 2005 and 2006. Levels above  $100 \mu\text{S}/\text{cm}^2$  typically indicate human disturbance. (See Section VIII. for site maps and river names)

**Macroinvertebrate Monitoring in Rivers and Streams:** As the collective drainage focus for the broader upstream landscape, in-stream conditions are a direct reflection of the environmental quality of the surrounding area. Physical/chemical conditions within a stream can be monitored directly. Such tests can identify the presence and quantities of specific problem substances such as those listed in Table 2. Monitoring natural water characteristics such as temperature, dissolved oxygen levels, pH, etc. also provides valuable clues as to the "health" of the stream or river – and thus the watershed -- under study. But because these observations tell you primarily about conditions "at the moment," it is often valuable to supplement such monitoring with biological surveys of the stream or river's resident organisms.

**Chapter V-A.4, Figure 5:** Macroinvertebrate taxonomic composition of 2006 samples for the Ossipee Watershed sites.

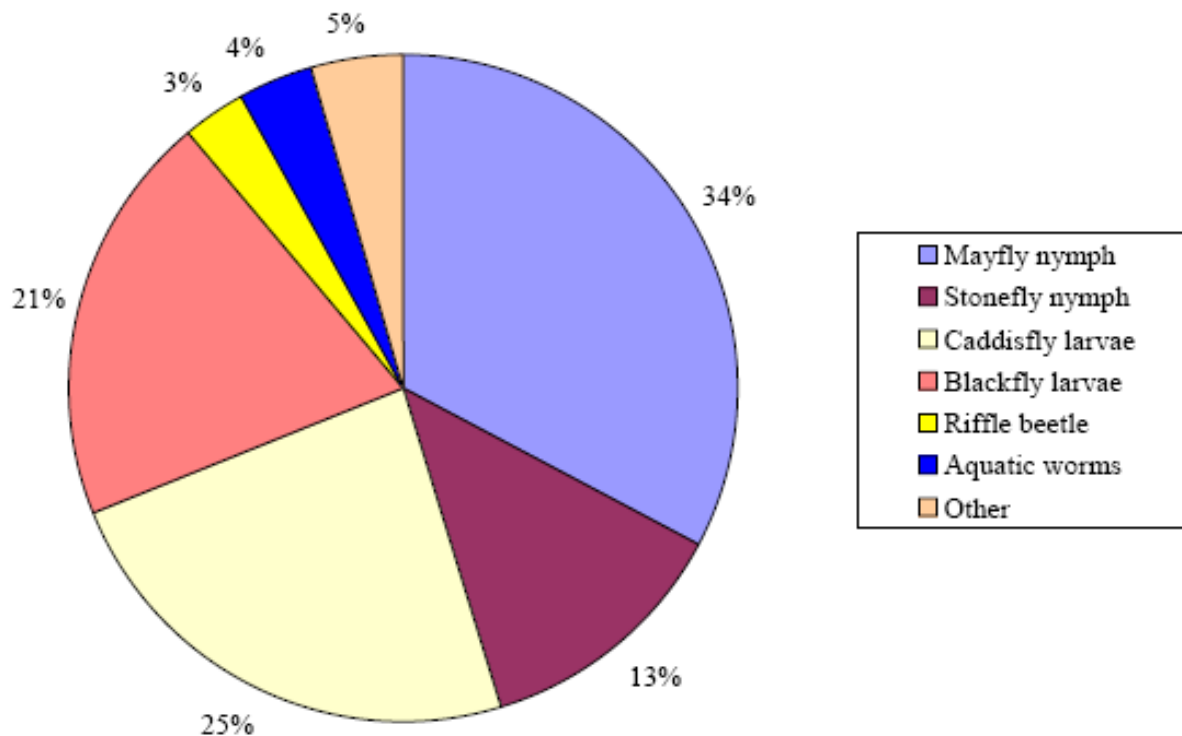

The presence of the biological community and especially of particular "indicator" species found at a given location depends on the availability of a range of required conditions during their lifetime. As long-term inhabitants of streams, the presence of such macroinvertebrates (i.e., larger invertebrate organisms such as insect larvae, clams, snails, etc. collectively referred to as "MIVs") reflects stream conditions that have occurred over the preceding days, weeks, months, or in some cases, years. Therefore, studies of macroinvertebrate communities provide valuable historical perspective missing in direct physical/chemical studies. Both physical/chemical monitoring and macroinvertebrate surveys are included in ongoing studies of the moving water systems of the Ossipee Watershed. Figure 5 shows that the taxonomic composition of 2006 samples from the eleven Ossipee Watershed sites. Stonefly nymphs, mayfly nymphs, and caddisfly larvae are usually the most pollution intolerant organisms. The fact that 72% of the MIV fauna in Watershed streams is comprised of these groups demonstrates the generally high quality of our streams. Table 2 summarizes the findings for 2006.

A complete report can be found at:

[http://www.gmcg.org/administration/pdf/2006\\_annual\\_report\\_final\\_20061218.pdf](http://www.gmcg.org/administration/pdf/2006_annual_report_final_20061218.pdf)

**Chapter V-A.4, Table 2: Biotic Scores for Ossipee Watershed Streams.** The biotic score and associated narrative quality of streams sampled in September 2006 for the VBAP where Biotic Index Scores 0 to 3.5 are excellent, 3.5 to 4.8 are good, greater than 4.8 are fairly poor. (2006 NH DES VBAP Report)

Site Number	Stream name, town	Biotic score	VBAP narrative category
1	Banfield Brook, Madison	4.66	good
2	Beech River, Ossipee	3.09	excellent
3	Forrest Brook, Madison	3.51	good
4	Swift River, Tamworth	5.00	fairly poor
5	South River, Parsonsfield	4.00	good
6	Mill Brook, Tamworth	3.88	good
7	Cold River, Sandwich	3.29	excellent
8	Bearcamp River, Tamworth	4.38	good
9	Lovell River, Ossipee	4.90	fairly poor
10	Cold Brook, Freedom	3.27	excellent
11	Pond Brook, Sandwich	3.13	excellent

### III. Current and Potential Threats to Rivers and Streams

Land development, forest harvest, and agricultural activities can alter conditions in rivers and streams. The loss of canopy cover leads to higher temperatures and lower oxygen levels. Disruption of vegetative cover within riparian corridors surrounding these systems leads to erosion, siltation, and easy access for non-point source pollutants – fertilizer, pesticide runoff, road salt (Figure 6) wash over aquatic inhabitants.

Historically, moving waters have been exploited as methods to transport all varieties of waste 'away' from one location, only to wind up as a problem downstream. As rivers and streams converge at watershed low points, their collective contributions can concentrate problems in lakes, ponds, and subsurface aquifers. As blood tests provide valuable information about conditions throughout human bodies, river and stream water quality tests reflect much about the watershed they drain. Table 3 illustrates the top causes of impairment to rivers and streams in New Hampshire.



**Chapter V-A.4, Figure 6: Snow Dumping and Road Salt.**

Road salt can negatively impact aquatic life, drinking water and roadside vegetation. Road salt is becoming an increasing threat to New Hampshire's rivers and ground water. Dumping snow directly into waterways introduces salt, sediment, debris and other contaminants directly into surface waters. Consult best management practices for guidelines to better manage snow from roadways:

<http://www.nh.gov/dot/bureaus/highwaymaintenance/documents/WinterMaintSnowandIcePolicy.pdf>

Chapter V-A.4, Table 3. **New Hampshire State-wide Top Causes of Impairments for Rivers and Streams**  
(modified from EPA 2002)

<b>Cause</b>	<b>Source</b>	<b>Risk</b>	<b>NH Miles of Impairment</b>
<b>Mercury</b>	Atmospheric deposition	Neurotoxin; biological magnification up food chain	969605.90
<b>Reduced pH</b>	Atmospheric deposition	Acidification of water; increased nutrient leaching from soils; build-up of metals in water	613.81
<i>Escherichia coli</i>	Septic failures, sewer overflow, excessive waterfowl	An indicator species revealing the potential for the presence of pathogenic organisms	415.41
<b>Polychlorinated Biphenyls (PCBs)</b>	Industrial/Municipal discharges; old power transformers	Carcinogenic; biological magnification up food chain; toxic to aquatic life	176.05
<b>Reduced dissolved oxygen levels</b>	Excessive organic decomposition; cultural eutrophication; livestock runoff	Loss of oxygen-demanding aquatic life; anaerobic byproduct toxins	137.18
<b>Lead, Iron, Copper, Arsenic, Cadmium, Chromium</b>	Natural, industrial, & mine drainage	Toxic to aquatic life; expensive remediation in drinking waters	97.89
<b>Non-native Aquatic Plants</b>	Boats, fishing gear, aquarium waste; some wildlife transport	Loss of native, stabilizing plant species; excessive organic productivity & decomposition; reduced recreation options and reduced land values	34.21

#### **IV. Recommendations**

**1. Monitor Water Quality.** Water quality professionals recommend long-term monitoring of rivers and streams, including: frequent and regular sampling; storm event sampling at various points along the river or stream to help pinpoint sources of potential increases in conductivity and nutrients rinsing into the flowing water; and tracking water quality trends to enable the identification of potential sources of pollutants from the watershed that may affect surface water quality. They emphasize that water quality trend analysis is not feasible with only a few data points, but that it takes many years to develop a meaningful set of water quality baseline data.

**2. Monitor Macroinvertebrate Communities.** An important "historical" perspective for our understanding of conditions within streams and rivers of the Watershed can be added through periodic surveys of the macroinvertebrate communities that characterize the major water flows. Ongoing volunteer help will be needed to implement the DES/EPA recommended sampling protocol currently followed in MIV sampling.

**3. Maintain Riparian Corridors.** An adequate undisturbed stream/river buffer of native riparian (i.e., stream-side) vegetation maintains the cool water temperatures that high quality biota require, and intercepts and filters non-point source pollutants such as sediments and chemicals before they reach the water flow. Since the Comprehensive Shoreland Protection Act (CSPA) does not apply to smaller (i.e., less than 4<sup>th</sup> order) rivers and streams, local communities are responsible for protecting these important buffers through land conservation and local regulations.

**4. Enforce Best Management Practices: BMPs** delineate proper handling and storage of substances to prevent harmful pollutants from entering surface and groundwater. By implementing these techniques, water quality can be protected by catching and filtering runoff and non-point source pollution before it enters and contaminates waterbodies. See Chapter V-c, Table 6 for examples of BMPs that protect surface waters.

## V. Helpful Links

DES Environmental Monitoring Database: <http://des.nh.gov/OneStop.htm>

DES Surface Water Quality Assessments [305(b)&303(d)]: [www.des.state.nh.us/wmb/swqa/303d](http://www.des.state.nh.us/wmb/swqa/303d)  
<http://www.des.state.nh.us/wmb/swqa/303dList.html>

Hubbard Brook Mercury Report: <http://www.hubbardbrookfoundation.org/article/view/13188/1/2076/>

NASA Global Change Master Directory: [www.gcmd.gsfc.nasa.gov](http://www.gcmd.gsfc.nasa.gov)

NH Rivers Council: [www.nhrivers.org](http://www.nhrivers.org)

River Network: [www.rivernetwork.org](http://www.rivernetwork.org)

Saco River Corridor Commission: [www.srcc-maine.org](http://www.srcc-maine.org)

Water Quality Standards: <http://des.nh.gov/wqs/>;

[www.epa.gov/waterscience/standards/wqslibrary/nh/nh\\_1\\_chapter1700.pdf](http://www.epa.gov/waterscience/standards/wqslibrary/nh/nh_1_chapter1700.pdf)

## VI. References

Merrill, Lorraine Stuart. "Healthy Trees, Healthy Water." *Forest Notes*. SPNHF, Spring 2006.

## VII. Model Ordinances for Surface Water Protection

The New Hampshire Regional Environmental Planning Program (REPP) is at work preparing an *Innovative Land Use Planning Techniques* Guide. A draft chapter from that Guide related to Shoreland Protection is available for review at the NH DES website: (<http://www.des.nh.gov/repp/index.asp?go=ilupth>). This chapter, including a model ordinance, is designed to assist communities that wish to adopt more stringent regulations for the protection of streams and surface water bodies than those currently prescribed by the state's Comprehensive Shoreland Protection Act, CSPA (RSA 483-B). For example, smaller, often headwater streams are abundant parts of the landscape throughout the Ossipee Watershed. These first, second, and third order streams are not currently included in the CSPA, yet they are especially vulnerable to sedimentation, pollution, and elevated temperatures/lowered oxygen. Eventually, they pass their cumulative contents along to larger downstream water bodies. In addition, municipalities may wish to define surface water protection standards that exceed those required by CSPA with regard to setbacks, percent impervious surface limitations, stormwater management plans for earth moving and excavation activities, permitting for water-dependent structures such as docks, breakwaters, boathouses, marinas, etc. See Chapter V A.3, Lakes and Ponds, section VII for the full model ordinance. For a listing of rivers and streams currently included within CSPA regulations, refer to (but note that more rivers and streams are expected to be added in the future – keep checking for updates):

<http://www.des.state.nh.us/cspa/fourth.htm>

Two current approaches serve as alternative models for the protection of the surface waters. In some cases, municipalities have adopted a comprehensive ordinance to address a number of related concerns regarding surface water quality. An example is The Water Quality Protection Ordinance adopted by New Durham, NH in 2007, shown below and available on line at:

[http://www.newdurhamnh.us/Land\\_Use/Zoning\\_Ordinance/2007%20Zoning%20Ordinance.pdf](http://www.newdurhamnh.us/Land_Use/Zoning_Ordinance/2007%20Zoning%20Ordinance.pdf)).

Other communities have chosen to address related subtopics individually. For example, The Ten Towns Committee in northern New Jersey follows this approach with specific model ordinances regarding Stormwater Runoff, Soil Erosion, Stream Buffers, and Wetland Protection. Their models may be viewed at <http://tentowns.org/10t/mointro.htm>.

**NEW DURHAM LAND USE AND ZONING  
ORDINANCE AS AMENDED 3/13/2007  
ARTICLE V: WATER QUALITY PROTECTION (adopted 3/14/2007)**

**A. AUTHORITY AND PURPOSE**

The surface waters (streams, rivers, lakes and ponds) and wetlands of New Durham supply drinking water, wildlife habitat, and recreation opportunities for the community. In order to preserve these critically important resources New Durham shall require conservation and land management practices which minimize environmental degradation and alteration of scenic and rural character.

The purposes of the Water Quality Protection Ordinance are: to protect public and private water supplies, to trap sediment and other pollutants in surface and subsurface runoff, to promote bank stabilization, to protect riparian wetlands, to minimize the impact of floods, to prevent decreases in base flow, to protect wildlife habitat, and to generally maintain water quality. The Water Quality Protection Ordinance ensures areas of restricted development and limited land use adjacent to surface waters and wetlands in New Durham. Riparian areas are generally defined as those areas that influence or are influenced by aquatic systems. For the purposes of the Water Quality Protection Ordinance, a Riparian Buffer Zone shall be defined as an upland area that is contiguous, and within the buffer setback requirements outlined in Section B, to a water resource that is considered jurisdictional by the NH Wetland Bureau as defined in RSA 482-A, the boundary of which has been delineated by a Certified Wetland Scientist, and the definition of which shall include vernal pools.

This ordinance has been enacted to implement the recommendations of the Town of New Durham Master Plan, and is authorized by RSA 674:21 (j), Innovative Land Use Controls, and Environmental Characteristics Zoning.

**B. APPLICABILITY**

The provisions of the Water Quality Protection Ordinance shall apply to all lots of 10 acres or less that are created by standard subdivision first filed after Town Meeting 2007; and to all lots and open space areas created by Open Space Conservation Subdivision first filed after Town Meeting 2007; provided this paragraph shall not prevent the Planning Board from adjusting the requirements of this Article as appropriate to accomplish the goals of the Open Space Conservation Subdivision, Article VI.

The Riparian Buffer Zone is an environmental overlay area superimposed over the conventional zoning map of the town. Property owners may initially consult the most recent USGS map of New Durham to determine if their Subdivision project area contains surface waters or wetlands that are likely to fall within the Riparian Buffer Zone. Any question of the applicability of this ordinance may require a wetlands delineation by a New Hampshire Certified Wetlands Scientist at the applicant's expense.

Note: The square footage area subject to this ordinance shall be countable toward meeting minimum lot size, lot area and density requirements for new subdivisions in accordance with

#### **Article IV B of the New Durham Zoning Ordinance.**

The provisions apply in the following areas of the Town of New Durham:

1. Perennial Streams and Rivers
2. Ponds and Lakes that are greater than 3000 square feet and less than 10 acres in size<sup>1</sup>
3. Wetlands that are not identified in Section B.4 below and that are greater than 3000 square feet.
4. Vernal Pools (as verified by a wetland scientist or qualified natural resource professional)<sup>2</sup>
5. Seasonal or Intermittent Streams
6. The Following Wetlands and Surface Waters of special local significance  
(Prime Wetlands or candidates, large or uncommon wetlands and headwater streams)
  - Cooper Cedar Woods
  - Davis Crossing Road, Old Bay Road and Mill Road Wetland (#1)<sup>3</sup>
  - Old Route 11 and the Davis Crossing Road Wetland (#2)
  - Wetland off of Drew Road (#3)
  - Wetland on northeast side of Route 11 (#4)
  - Wetland southwest of Route 11, close to Ridge Road, Valley Road (#5)
  - Wetland on inlet on eastern shore of Merrymeeting Lake (#6)
  - Wetland along southwestern shorelines of Chalk Pond and March's Pond(#8)
  - Wetland at headwaters of the Ela River (#9)
  - Wetland north of Caverly Road and southwest of Shaw's Pond (#10)
  - Wetland in SE between Middleton Road, Old Bay Road (#11)
  - Ela River
  - Beaver Brook
  - Cocheco River
  - Hayes Brook
  - Mad River
  - Merrymeeting River
  - Peter Brook
  - Unnamed River (outlet of Coldrain Pond into Club Pond)
  - Goodwin Brook
  - Jennings Brook

<sup>1</sup> For Great Ponds (10 acres or larger in size) see Article VIII.

<sup>2</sup> For information on verification of Vernal Pools refer to Identification and Documentation of Vernal Pools in New Hampshire. Second Edition (2004). New Hampshire Fish and Game Department Nongame and Endangered Wildlife Program.

<sup>3</sup> These wetlands are delineated on the map entitled "Significant Wetlands & Surface Waters", prepared by biologist Chris Kane as part of his contract in 2006 to help the Town of New Durham prepare this ordinance.

**C. RIPARIAN BUFFER ZONE SETBACK REQUIREMENTS**

<b>TABLE 1. BUFFER SETBACK DISTANCES IN FEET BY RESOURCE AND USE CATEGORY</b>				
<b>A. BUFFER</b>	<b>B. BUILDINGS</b>	<b>C. SEPTIC</b>	<b>D. IMPERMEABLE</b>	<b>SURFACE WATER &amp; WETLAND RESOURCES</b>
35'	75'	100'	50'	Perennial Streams and Rivers
25'	75'	100'	50'	Lakes and Ponds (<10 acres)
25'	75'	75'	50'	Wetlands
50'	75'	75'	50'	Vernal Pools
25'	50'	75'	50'	Seasonal or Intermittent Streams
75'	100'	125'	75'	Wetlands and Surface Waters of Local Significance
50'	100'	100'	75'	Wetlands Contiguous to Lakes and Ponds >10 acres
A. Naturally Vegetated Buffer Strip (see Section H.1.) B. Buildings and Structures Setback C. Septic Systems Setback D. Impermeable Surfaces Setback (see Definition, Section L.)				

**1. Base Setbacks**

Table 1 above identifies the base buffer setback requirements for each identified resource type. Buffer setback distances in Table 1 refer to the total horizontal distance in one direction from a water resource Reference Line. See definition of Reference Line, Section L. In cases where an area qualifies under more than one resource category, the largest buffer/setback distance shall apply.

Table 2 below shows how much the naturally vegetated buffer strip must be increased in properties with steep slopes.

Larger buffer or setback distances may be required on a site-specific basis to protect against water quality degradation and to preserve significant wildlife and botanical habitats. The Town may look to the following documents (or as amended) or other documents for guidance as to the sensitivity of a habitat/resource and for recommendations for protective measures such as enlarged buffers and setbacks:

- a. Good Forestry in the Granite State: Recommended Voluntary Forest Management Practices for New Hampshire. 1997. NH Division of Forests and Lands (DRED) and the Society for the Protection of New Hampshire Forests.
- b. Identifying and Protecting New Hampshire’s Significant Wildlife Habitat: A Guide for Towns and Conservations Groups. 2001. Kanter, J., R. Suomala, E. Snyder, et al. Nongame and Endangered Wildlife Program of the New Hampshire Fish and Game Department.



c. Threatened and Endangered Plants and Animals in New Hampshire's Forested Habitats. 1998. UNH Cooperative Extension, NH Fish and Game Department, US Fish and Wildlife Service.

**2. Steep Slope Adjustments**

Steep slope areas will also be considered in determining the width of a vegetated buffer strip. If the vegetated buffer strip designated in Column A of Table 1 contains an area which has a slope of 10% or more for more than 10 linear feet in a direction perpendicular to the edge of a water resource, the width of the vegetated buffer zone will be increased as shown in Table 2.

<b>TABLE 2: DISTANCE ADJUSTMENTS FOR STEEP SLOPE AREAS</b>	
<b>SIDE SLOPE (PERCENT)</b>	<b>NATURALLY VEGETATED BUFFER STRIP (FEET)</b>
0-9.9 %	No additional distance
10 -19.9 %	15 additional feet
20-29.9 %	35 additional feet
30-39.9 %	55 additional feet
40 % or more	Buffer to extend up-slope until slope is less than 40% for at least 10 linear feet in a direction perpendicular to the Reference Line

**D. PERMITTED USES**

The following uses, if otherwise permitted in the underlying zoning district, shall be permitted in the naturally vegetated buffer strip, provided that they shall be conducted according to the applicable provisions. Such uses may include the following:

1. Trails or paths for non-motorized recreational purposes, and for motorized vehicles on snow;
2. Removal of dead, diseased, unsafe, or fallen trees;
3. Construction or placement of sheds or structures which occupy a ground area no greater than 150 square feet in size that are incidental and subordinate to the primary structure of the property and do not require the disturbance or improvement of the soil surface or construction of a sub-surface foundation may take place no closer than 20 feet from the water resource reference line;
4. Beaches that were existing prior to the March 2007 Town Meeting on lakes and ponds. New perched beaches may be created on lakes and ponds with the prior permission of the Conservation Commission

## **E. EXEMPTIONS**

In this Ordinance, “manmade” shall refer to recent structures or changes to the landscape and shall not include cellar holes, gravel pits, abandoned dams or other prior manmade alterations that have become, over time, part of the natural topography.

Any of the following features shall be exempt from this ordinance:

1. Manmade ditches, swales and storm-water management devices.
2. Manmade sedimentation/detention basins or ponds.
3. Rural use manmade ponds such as agricultural ponds, fire ponds, wildlife ponds, and the like, provided that they meet the Department of Environmental Services (DES) standards for design and construction.

## **F. CONDITIONAL USE IN THE RIPARIAN BUFFER ZONE**

The New Durham Planning Board will be responsible for reviewing and permitting any Conditional Uses according to the following criteria:

The following uses may be permitted as conditional uses in the Riparian Buffer Zone:

1. The construction of streets, roads, access ways, bridge crossings, and utilities including pipelines, power lines, and transmission lines and related structures if essential to the productive use of land not defined as wetlands.
2. Outdoor recreational facilities that do not require the construction of buildings.
3. Trails and associated structures for use by year-round motorized recreational vehicles.

The Planning Board may approve a Conditional Use Permit for a use in the Riparian Buffer Zone only if it finds, with the advice of the New Durham Conservation Commission, that all of the following standards have been met in addition to any performance standards for the particular use:

1. There is no alternative location on the parcel that is outside the riparian buffer zone that is feasible and reasonable for the proposed use.
2. The amount of soil disturbance will be the minimum necessary for the construction and operation of the facilities as determined by the planning board.
3. The location, design, construction, and maintenance of the facilities will minimize any detrimental impact on the riparian buffer zone and mitigation activities will be undertaken to counterbalance any adverse impacts;
4. Restoration activities will leave the site, as nearly as possible, in its existing condition and grade at the time of application for the conditional use permit; and
5. The proposed activities would not disturb habitat for rare, threatened or endangered species or exemplary natural communities, such determination to be made by the New Hampshire Natural Heritage Bureau.

## **G. PROHIBITED USES**

Any use that is not identified as a permitted use in Sections D or F of this Article shall be a prohibited use in the naturally vegetated buffer strip

## **H. PERFORMANCE STANDARDS IN THE RIPARIAN BUFFER ZONE**

All construction, alteration, placement, storage, introduction or movement of structures or land in the Riparian Buffer Zone shall conform with the following performance standards:

### **1. Naturally Vegetated Buffer Strip**

A Naturally Vegetated Buffer Strip adjacent to surface waters and wetlands to stabilize upland areas to prevent erosion, maintain wildlife habitats, and minimize pollution of the water shall be permanently maintained All existing vegetation including trees, shrubs and undergrowth shall be allowed to remain undisturbed within the Naturally Vegetated Buffer Strip, as required

in Tables 1A and 2 . Not-with-standing the foregoing, removal or control by non-chemical means of invasive non-native or poisonous plant species shall be allowed in the Naturally Vegetated Buffer Strip. No soil disturbance, removal or cutting of vegetation or introduction of structures or materials of any kind shall occur within this naturally vegetated buffer, except as may be allowed in Section C herein or may be granted through a conditional use permit outlined in Section E herein.

The size of the Naturally Vegetated Buffer Strip shall be established according to Tables 1A and 2 in Section C of this ordinance, and shall extend the entire length of any portion of any water resource occurring within the subject property.

## 2. Sedimentation and Erosion Control

All activities, construction and the use of buildings, structures, and land within the Riparian Buffer Zone shall be carried out so as to minimize the volume and rate of storm water runoff, the amount of erosion, and the export of sediment from the site. No structure or building, impermeable surface such as a paved driveway or parking area nor related topographical alteration shall be located, constructed or occur within the distance from the water resource reference line specified in Tables 1A and 2 above, except as may be allowed in Section C herein or may be granted through a conditional use permit outlined in Section E herein.

All such activities shall be conducted in accordance with Best Management

Practices for storm water management including but not limited to:

- a. Best Management Practices to Control Non-point Source Pollution: A Guide for Citizens and Town Officials, NHDES, January 2004.
- b. Innovative Storm-water Treatment Technologies Best Management Practices Manual, NHDES, 2002.

## **I. SEPARABILITY**

If any section, provision, portion, clause or phrase of this article shall be held invalid or unconstitutional by any court or competent authority, such holding shall not affect, impair or invalidate any other section, provision, position, clause or phrase of this ordinance.

## **J. CONFLICT WITH OTHER REGULATIONS**

Where any provision of this article is in conflict with State law or another local ordinance, the more restrictive regulation shall apply.

## **K. IDENTIFICATION OF BUFFER, ENFORCEMENT, AND DEED REFERENCE**

### 1. Identification

The subdivision applicant shall be responsible for showing a building envelope on each lot of the subdivision plan. The envelope will designate the outer limits of allowable construction for all buildings on the lot.

The subdivision applicant shall be responsible for placing a permanent monument (e.g., iron pin, granite bound) at all points of the lot lines which intersect with the upland limit of the naturally vegetated buffer strip prior to the start of any construction related activities. These monuments shall be shown on the subdivision plan.

The entire length of the upland limit of the naturally vegetated buffer strip shall be marked with highly visible construction tape prior to and for the full duration of construction related activities. The applicant shall also be responsible for affixing tags to trees or other durable objects (metal stakes, etc.), at intervals deemed acceptable by the planning board, along the upland boundary of the naturally vegetated buffer strip, and maintaining said tags as needed to provide evidence of the

upland side buffer boundary. Under no circumstance shall the tag interval be required to be closer than 25 feet. Tags shall be obtained from the Town.

## 2. Enforcement

The Town of New Durham retains the right to inspect any property which is subject to this ordinance for the purposes of determining compliance.

## 3. Riparian Buffer Zone Reference in Deeds

A description of any applicable portions of the Riparian Buffer Zone shall be included in any deeds subsequently conveying all or a portion of a property, along with a reference to the recording information for any pertinent Plan Number from the Registry of Deeds.

## L. DEFINITIONS

**Building Envelope:** An area designated on each lot of a subdivision plan as the area where a dwelling and other buildings may be constructed.

**Water Resource:** All or a portion of a pond, wetland, lake, perennial stream, seasonal or intermittent stream, river or vernal pool.

**Wetland:** An area that is inundated or saturated by surface water or ground water at a frequency and duration sufficient to support, and that under normal conditions does support, a prevalence of vegetation typically adapted for life in saturated soil conditions.

**Vernal Pool:** a confined depression in which water is present for at least two continuous months in the spring and/or summer; and which becomes completely dry during a portion of the year (or other documentation proving the absence of adult fish populations) and which contains physical evidence that it is utilized by at least one species of which requires a vernal pool for a portion of breeding (including Spotted Salamander, Jefferson Salamander, Wood Frog, Fairy Shrimp).

**Seasonal or Intermittent Stream:** Any stream shown as a seasonal or intermittent stream on a USGS 7.5 minute series topographic map. Also any other stream that flows for sufficient time to develop and maintain a defined channel with some sign of regular scouring and/or deposition of soil material, but which might not flow during dry portions of the year.

**Reference Line:** The ordinary high water mark indicated by the line on the shore or edge of a lake, pond, and in the case of a stream or river running parallel to its main stem, established by the fluctuations of water and indicated by physical characteristics such as a clear, natural line impressed on the immediate bank, shelving, changes in the character of soil, destruction of terrestrial vegetation, the presence of litter and debris, or other appropriate means that consider the characteristics of the surrounding areas. For artificially impounded fresh water bodies with established flowage rights, the Reference Line shall be the limit of the flowage rights, and for water bodies without established flowage rights, the Reference Line shall be determined at full pond by the elevation of the spillway crest. For all other wetlands including marshes, bogs, swamps and vernal pools the reference line shall be the line delineated as the wetland edge by a Certified Wetland Scientist in concurrence with the New Durham Conservation Commission.

**Slope:** Degree of deviation of a surface from the horizontal, measured as a numerical ratio, as a percent, or in degrees. Expressed as a ratio, the first number is the horizontal distance (run) and the second number is the vertical distance (rise), as

2:1. A 2:1 slope is a 50% slope. Expressed in degrees, the slope is the angle from the horizontal plane, with a 90 degree slope being vertical (maximum) and a 45 degree slope being a 1:1 slope.

Impermeable Surface: Driveways, parking areas, walkways, or other features introduced to a property that are constructed of materials such as concrete, asphalt or stone that essentially prevent the passage of water through them to the soil substrate below.

## VIII. Additional Material/Documents

### **New Hampshire Department of Environmental Services (NH DES) On-Line Resources.**

The New Hampshire Department of Environmental Services website (<http://www.des.state.nh.us/>) offers easily accessible information regarding responsibilities and opportunities for state, municipal, and individuals to address water resource issues. Here are brief summaries of just some of these links that relate to Moving Water issues.

#### SURFACE WATER QUALITY – RIVERS:

[Watershed Management Bureau - Rivers Management and Protection Program \(RMPP\)](#) was established in 1988 with the passage of [RSA 483](#) to protect certain rivers, called [designated rivers](#), for their outstanding natural and cultural resources. Designation for protection requires municipal nomination, state review, and eventually Legislative approval. After designation, a [management plan](#) is developed so that the outstanding qualities of the river may be protected for future generations. The plan is developed and implemented by a volunteer local river advisory committee that also coordinates activities affecting the river on a regional basis. A typical plan identifies management goals and recommends actions that may be taken to protect the resources identified in the nomination. This site includes more information about the process as well as links to Rivers Management and Protection Act (RSA 483), [NH Stream Gage Task Force](#), [Guidelines for Naturalized River Channel Design and Bank Stabilization](#), and more. Visit: <http://www.des.state.nh.us/Rivers/>

# Ossipee Watershed Coalition Natural Resources Planning Guide Chapter V – B Wetlands

## I. Introduction – Why are Wetlands Important?

All wetlands have **functions** that serve the surrounding *ecosystem*. All of these functions also contribute to the well being of humans, therefore they are highly valued by society.



The following list of functions and values represent the most commonly recognized benefits associated with wetlands. Can you think of others that we have left out?



**Wildlife Habitat** – Wetlands and their adjacent upland habitat offer more food, shelter, and reproduction options for wildlife than any other land-based ecosystem. Over 70% of all vertebrate wildlife use wetlands during a significant portion of their life cycle. For amphibians, this figure is over 90%. The highest level of invertebrate biodiversity is also found at the upland/wetland interface.

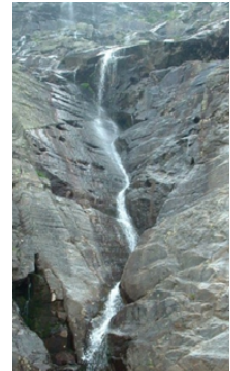

**Groundwater Recharge/Discharge** – Wetlands serve as places where water recharges to underlying aquifers as well as places where water discharges onto the surrounding landscape. Stream channels are excellent places for water



recharge and the toe slopes of hills and mountains are excellent places for water discharge. Both are critical elements in providing drinking water supplies to wildlife and to human society.

**Sediment and Toxicant Removal & Attenuation** – Low lying landscapes are the receiving areas for fine particulate sediments and associated nutrients. Some of these can be toxic to fish and other forms of wildlife, including humans. Wetlands act as sediment traps, and the high amount of biological activity serves to break down nutrients and pollutants into harmless forms.

**Floodwater Storage & Dissipation of Erosive Forces** – Marshes and swamps can absorb a tremendous amount of stormwater, particularly in the spring when water tables are high. The rapid uptake and gradual release of flood waters has saved society billions of dollars over time. Bordering vegetated wetlands along streams,



rivers, pondshores and lakeshores have also played an important role in protecting the integrity of shorelines.



**Production Export** – Wetlands, especially estuarine and marine intertidal zones, produce more carbon-based foods than any other ecosystem. Hydric soils, if carefully managed, also yield more food

and fiber for society than any other agricultural soil. Forested swamps have been shown to sequester high amounts carbon – an increasingly important attribute in this era of global warming.

**Education / Scientific Research** – The study of wetlands has produced important facts about ecosystem processes – in fact, the very first experimental design studies of the modern era looked at intertidal wetlands. The high concentration of micro-habitats and the ecosystem processes that regulate them make wetlands prime subjects of biological study.



**Visual & Aesthetic Resources** – Often under-rated, the visual qualities of wetlands offer a welcome break amidst a landscape that is fragmented by development. Real estate values are typically higher near wetlands and water bodies than anywhere else in a given locale.

## II. Description of the Resource

### WETLANDS & OPEN WATER IN THE OSSIPEE WATERSHEDS TOWNS

Municipality	Total Acres	Total Water Acres	Total Hydric Soil Acres	Total NWI Acres	Land Acres	Land Square Miles
Effingham	25,555.9	728.9	6,461.3	4,094.8	24,827.0	38.8
Freedom	24,261.9	2,204.3	1,688.8	683.1	22,057.7	34.5
Madison	26,157.3	1,510.6	3,315.5	1,307.8	24,646.7	38.5
Ossipee	48,168.5	3,089.7	6,428.3	4,088.5	45,078.8	70.4
Sandwich	60,250.8	2,084.5	5,048.6	3,291.1	58,166.4	90.9
Tamworth	38,812.6	691.6	3,089.0	1,493.7	38,121.0	59.6

Chapter V-B Table 1. Comparison of open water versus wetlands in the six town area<sup>1</sup>

<sup>1</sup> Acreages for land area, water, hydric soils and National Wetland Inventory (NWI) wetlands provided by NH GRANIT (<http://www.granit.sr.unh.edu/>). Water area derived from U.S. Geological Survey (USGS) sources for all hydrographic areas except wetlands (i.e. lakes, ponds, rivers, and streams), hydric soils from the Natural Resource Conservation Service (NRCS), and NWI wetlands from the U.S. Fish & Wildlife Services’ Wetlands Mapping Program. In all cases, the hydric soil values for wetland acreages are higher than the NWI acreages. Actual wetland acreages on the ground are typically in between these values (see below). Note that the amount of land acres and square miles includes wetlands but not open water.

**A. DEFINITIONS – What is a Wetland?**

*Wetlands include those areas that are inundated or saturated by surface or groundwater at a frequency and duration to support, and that under normal circumstances do support, a prevalence of vegetation typically adapted to life in saturated soil conditions.*

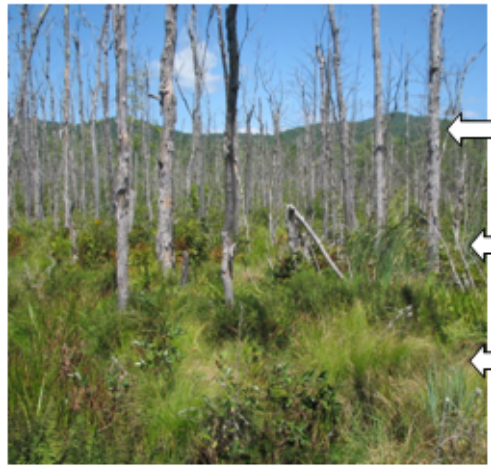

- Hydrophytic Plants
- Hydric Soils
- Hydrology

**B. TECHNICAL CRITERIA – Federal & State**

- Vegetation**
  - Prevalence indicated by 50% dominance measure (usually areal cover)
  - Adaptations include buttressing, stooing, multiple trunks, inflated root cells
- Soils**
  - Saturation typically creates a thick surface organic layer
  - Subsurface often grayish, or with mottles that reflect oxidation/reduction of Fe
- Hydrology**
  - Water at or near the surface for ≥12.5% of the growing season
  - Usually two weeks or more



**C. CLASSIFICATION – the Cowardin System**

**P** = Palustrine, or a non-tidal freshwater wetland. It is one of 5 major systems:  
 Marine  
 Estuarine  
 Lacustrine  
 Riverine  
 Palustrine

**FO** = Forested, one of 5 vegetated cover types in the Palustrine system:  
 (FO) Forested; (SS) Scrub-shrub; (EM) Emergent; (AB) Aquatic Bed; (ML) Moss-Lichen

**E** = Seasonally Flooded/Saturated, one of about 10 different water regime modifiers that describes hydrology

**P FO 1/4 E**

**1** = Broad-leaved Deciduous (e.g. Red Maple)  
**4** = Needle-leaved Evergreen (e.g. Hemlock)  
 1 / 4 means that the deciduous trees are slightly more dominant than the conifers





## D. WETLAND MAPPING & DELINEATION

### How do I find a good wetlands map for my town?

Wetlands maps are easily available from various federal or state agencies. A good starting point is the **National Wetlands Inventory (NWI)**, a branch of the U.S. Fish & Wildlife Service that is responsible for classifying and mapping all wetlands in the United States. There are over 200 quad sheets – equivalent in size to the USGS topographic quads – of nearly all areas of the state. These are available on-line at <http://www.fws.gov/nwi/> or as hard copy maps (for a small copying fee) through the N.H. Office of Energy and Planning.

The second most-often used source for wetland maps on a local or regional scale is the **Natural Resource Conservation Service or NRCS** (formerly the Soil Conservation Service). They have the responsibility of maintaining and updating soil maps for every county in the United States, including the depiction of *hydric soils*, which are roughly equivalent to areas of wetland. These maps can be obtained through the Soil Data Mart at <http://soildatamart.nrcs.usda.gov/>.

Chapter V-B Figure 1 - 1998 Aerial photo base map



### How accurate are these maps?

Both of the above sources of wetlands information were largely derived from remote data sources – i.e. from high altitude aerial photographs. These were interpreted by mapping specialists using very large-scale maps. It is a stated fact by the agencies that publish these maps that there are certain levels of error in these maps, for instance, up to 3 - 5 acres of upland within a hydric soil map unit. As a general rule, NWI maps *underestimate* the actual amount of wetlands on the ground and NRCS hydric soil maps *overestimate* the amount of wetlands on the ground.

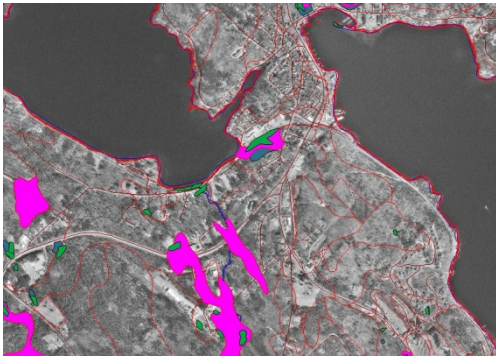

Chapter V-B Figure 2 Aerial Photo with NRCS hydric soils and NWI wetlands data

### How can I improve the accuracy of these maps?

Perhaps the best (and least expensive) way to check the accuracy of the NWI and NRCS wetland maps is to have a mapping professional utilize existing, high altitude photography to re-interpret the location of wetlands on the ground. The advantages of doing this are 3-fold: 1) there are already several sources of high-altitude photography available for review; 2) the most recent aerial photography is likely much more up-to-date than that used for the initial mapping by the NWI or NRCS; and 3) by using a combination of black-and-white, color infrared and/or stereoscopic (3-D) images of the ground,

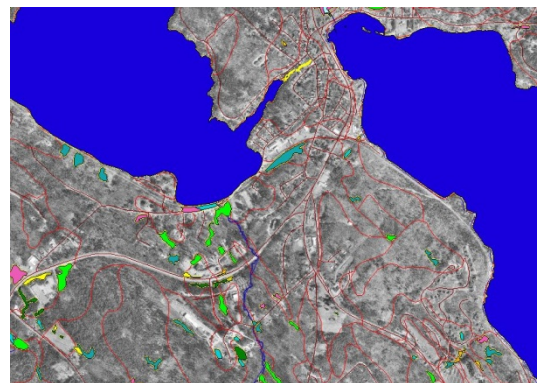

Chapter V-B Figure 3 Aerial photo interpretation map - final

much greater resolution and accuracy can be effected. There are several sources of high-altitude aerial photographs for download and review – perhaps the most complete source is the New Hampshire Geographically Referenced Analysis and Information Transfer System (NH GRANIT), which is located on-line at [http://www.granit.sr.unh.edu/cgi-bin/load\\_file?PATH=/about](http://www.granit.sr.unh.edu/cgi-bin/load_file?PATH=/about).

### What About Wetland Delineation?

The best way to derive an accurate map for a given area is to have a certified wetlands professional conduct an on-the-ground wetland delineation of the area in question. There are over 200 Certified



Wetland Scientists (CWS) in the state of New Hampshire and their contact information is provided by the certifying body, the N.H. Joint Board of Natural Scientists at <http://www.nh.gov/jtboard/ns.htm>. Wetland delineators are required to follow state and federal wetland guidelines as defined above, yet map standards depend upon the intended use of the map. For small-scale development projects involving wetlands, the state mapping standards of +/- 10 feet must be adhered to, that is, the wetland line depicted on any map sheet must be within 10 feet of the actual line of the ground. For larger scale mapping projects, such as a town-wide map, the map standards can be relaxed *as long as they are clearly stated on the map*.

*Wetland delineations are never 100% accurate!* Owing to varying environmental conditions over time, as well as the professional judgment of the delineator, wetland lines as flagged in the field may vary.

[Note that it is within the powers of the Planning Board to contract an independent review of any wetland delineation performed by a developer.] While this may cause some consternation among town officials and concerned citizens, the important thing to note is that **wetland functions do not stop at the wetland line!** Whenever a development project is being planned that impacts wetlands, it is essential for all reviewers of the proposed project to consider what essential functions – those invaluable services that promote the public good – are being lost or otherwise irreparably impaired. Only then can adequate mitigation for wetland impacts be crafted and adhered to. A comprehensive set of wetland **regulations** at the federal, state, and local level typically offer guidelines for understanding and minimizing the effects of human impact on wetland functions and values.



## E. WETLAND REGULATIONS

### 1. FEDERAL

Federal regulations arise from several laws that have been passed over the past 110 years. The 1899 Rivers and Harbors Act established the United States governmental authority over navigable rivers and interstate commerce on them, and created the U.S. Army Corps of Engineers as the lead agency to oversee such activities. Since then, several laws have modified the jurisdiction over “waters of the United States,”



but no act has had such a sweeping effect as the **Federal Water Pollution Control Act** of 1974 and its subsequent amendment in 1977 known as the **Clean Water Act**.

These laws defined wetlands and included them under the regulation of surface waters, as well as certain lands that are adjacent. They provided a permitting mechanism for filling and dredging waterways and wetlands, which included oversight of permit approvals by the U.S. Environmental Protection Agency, and classification and mapping authority of the U.S. Fish & Wildlife Service. Agricultural impacts to wetlands and surface waters were to be administered by the Soil Conservation Service (now Natural Resource Conservation Service), as set out by subsequent legislation such as the **Food and Security Act of 1985**.

For Further Information: <http://www.nae.usace.army.mil/> ; <http://www.epa.gov/owow/wetlands>

## 2. STATE

The state of New Hampshire adheres to the regulatory authority of the United States Government, yet has actually protected wetlands on its own since 1969. Under a cooperative agreement with the U.S. Army Corps of Engineers known as the **Statewide Programmatic General Permit** or SPGP, the state handles all permitting activity for impacts to wetlands yet shares permit applications for larger projects with the Army Corps for their review and consideration. Unless the project is a large one (generally > 1 acre of impact), permits need only be applied for to the state Wetlands Bureau. The jurisdictional authority of the state of New Hampshire is slightly different, however, since it includes all lands within 100 feet of the highest observable tide line *and* intermittent streams. Statewide jurisdiction also includes certain isolated wetlands that, based on a recent Supreme Court decision, currently fall outside of federal regulatory authority. The state administers their wetlands program through the **Department of Environmental Services Wetlands Bureau**, with permitting approval oversight by the governor-appointed **Wetlands Council**.



For Further Information: <http://www.des.state.nh.us/wetlands/> ; <http://www2.des.state.nh.us/OneStop/>

## 3. LOCAL

Local wetlands authority is usually derived from a local ordinance or zoning provision that regulates projects that impact wetlands within the municipal boundary. There are at least 65 towns in the state that have some type of local restrictions that address wetland impacts. Most of these are stand-alone ordinances that were passed by a majority of town voters as a part of an annual warrant article. In the early 1980's there was a considerable effort on behalf of the state and regional planning agencies to get local wetland ordinances passed and adopted in New Hampshire. Many of these earlier ordinances look the same and have "boiler-plate" provisions that include a purpose section, a definitions section, a permitted

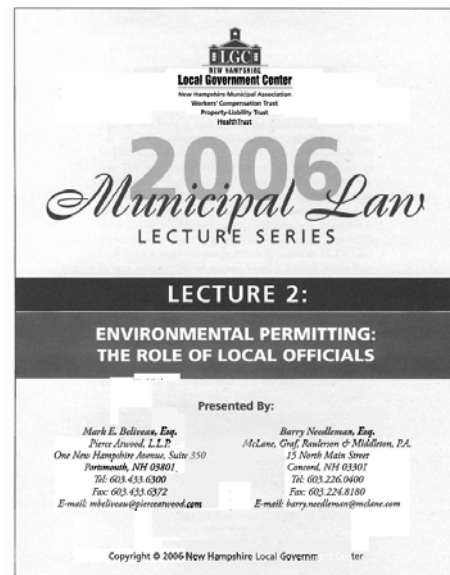

of

uses section, a section on special exceptions, and a special provisions section that addresses specific setbacks. Utilizing the fairly well-known section A:15 of RSA 482-A, many towns have added **prime wetland** language to their original wetland ordinance. While there are many different versions of these sections, as well as a number of unique special provisions dealing with subdivisions and site plan review, it is important to note that since 1980, a large number of **court cases have upheld the rights of municipalities to regulate, protect and conserve wetlands at a more rigorous standard than either the state or the federal government.**

**For Further Information:** See above document inset, available through the Local Government Center at <http://www.nhlgc.org/>  
<http://www.nh.gov/government/laws.html> ; <http://www.nh.gov/htdig/> ;  
<http://www.gencourt.state.nh.us/ie/billstatus/billstatuspwr.asp> ; <http://des.state.nh.us/wetlands/Guidebook/primewet.htm>

### III. CURRENT AND POTENTIAL THREATS TO OUR WETLANDS

Since the onset of European settlement, we have lost roughly one half of the 224 million acres of wetland resources in the United States. In 1977, President Jimmy Carter signed Executive Order 11990, “Protection of Wetlands” that required all federal agencies to "take action to minimize the destruction, loss or degradation of wetlands and enhance the natural and beneficial values of wetlands." A decade later, as a direct result of the National Wetlands Policy Forum, the “No Net



Loss” policy was established by the George H.W. Bush administration to "achieve no overall net loss of the nation's remaining wetlands base and to create and restore wetlands, where feasible, to increase the quantity and quality of the nation's wetland resource base." In spite of these gains, and support for wetlands conservation from all federal agencies since the Carter administration, there are still over 97 million acres of “prior converted” agricultural wetlands in the United States.

In the previously glaciated Northeast, where wetland losses were largely confined to coastal areas, the No Net Loss policy has brought about the restoration of previously dammed, ditched, or degraded salt marshes. In freshwater wetland areas, **losses due to agriculture has been replaced by losses due to commercial and residential development.** In New Hampshire, over 2400 dredge & fill permits are issued each year by the Wetlands Bureau, and in 2005 this represented about 198 acres of wetland loss, nearly all of which was attributable to development. Therein lies the greatest current potential threat to our wetland resources.

But what about *wetland function*? Both the filling of wetlands and the fragmentation of uplands has continued to impair the functional ability of New Hampshire’s wetlands to be of benefit to ecosystems and human society. **Cumulative wetland loss** has continued to be the target of both federal and state wetland mitigation rules that seek to prevent the ultimate disintegration of wetland function.

Municipalities that seek to prevent such cumulative wetland loss within their towns should pay close attention to the following threats to our wetland resources:

1. **Fragmentation of wetland complexes and their upland buffer habitat**
2. **Impacts of existing and proposed roads on the free passage of wetland dependent wildlife**
3. **Impairment of wetland function due to stormwater-borne loading of sediments, toxicants, and nutrients**
4. **Interruption of ground and surface water flows that regulate wetland hydrology**

#### **IV. RECOMMENDATIONS**

Given the above threats to wetland resources, several recommendations arise for the protection and conservation of local wetlands. The following list provides some initial guidance on ways in which municipalities can identify, evaluate, and implement actions to prevent the destruction of naturally occurring wetlands and water bodies. Keep in mind that there are several intermediary tasks within each of the Action Steps below, each of which have budgetary and/or personnel resource considerations that may take one or more years to implement fully.

- Objective: Identify where wetland resources exist in town
  - Action Step: Review existing maps in municipal archives
  - Action Step: Obtain additional wetland map resources as indicated in Section II.4 above
  - Action Step: Complete field-based update of wetland units and their location
- Objective: Evaluate wetland resources in town
  - Action Step: Assess each wetland map unit or complex for wetland functions
  - Action Step: Compare and contrast wetland units numerically and graphically
  - Action Step: Present and review assessment data and draft list of highest value wetlands in town
- Objective: Protect and conserve wetland resources in town
  - Action Step: Devise strategies for conserving most valuable wetland complexes through direct land conservation – e.g. fee purchase, conservation easements, deed restrictions
  - Action Step: Draft, review, and/or update wetland ordinances or bylaws

#### **SOME IMPORTANT CONSIDERATIONS FOR DRAFTING WETLAND ORDINANCES**

For towns to derive meaningful protection of wetland resources at the local level, clear and precise language needs to be written into local regulations. Some essential characteristics that build upon the “boiler plate” provisions described in Section II.5.C above include:

- Is there a clear Purpose & Intent section that dovetails the existing municipal master plan?
- Does the Purpose & Intent identify specific wetland functions that are being protected?
- Can each of the Permitted Uses meet these criteria on their own merits?
- Is the Definitions section up to date – i.e. does it reflect the latest regulatory language of the state of New Hampshire?
- Are both Certified Soil Scientists and Certified Wetland Scientists recognized in the Definitions section as being capable of performing wetland science work in your Town? How about Septic System Designers as far as siting septic systems from the ‘edge of wet’?
- Do activities under the Permitted Use Sections identify specific *Best Management Practices* as performance standards for agriculture, forestry, and other land management activities?

- Do special exceptions exist for non-conforming lots? If not, do you know how many non-conforming lots exist in your Town – i.e. under a ‘build-out’ scenario how many will require variances or waivers in order to meet local setback regulations?
- **Are your setback distances scientifically based?** If not, what standard(s) do they adhere to?
- Do you have a *natural vegetation buffer* for all activities near wetlands? If not, why not?
- Do you have any Special Provisions for protecting your highest value wetlands – e.g. *prime* wetland protection provisions?

## V. Helpful Hints / links / Resources

<http://www.ncseonline.org/NLE/CRSreports/water/h2o-32.cfm?&CFID=6651132&CFTOKEN=63348480> – Clean Water Act summary

<http://www.epa.gov/airprog/oar/caa/index.html> - Clean Water Act text

<http://eprints.law.duke.edu/archive/00001238/> - article on No Net Loss Policy

Mitsch, William J., and Gosselink, James G.. 2000. *Wetlands*. 2<sup>nd</sup> ed. New York: John Wiley and Sons.

U.S. Environmental Protection Agency. 1998. *The Quality of Our Nation's Water: 1996. Executive Summary of the National Water Quality Inventory: 1996 Report to Congress*. EPA 841-S-97-001. April.197p.

# **WETLANDS MODEL ORDINANCE**

## **1.0 Title**

This ordinance shall be known as the “Wetlands Ordinance of the Town of \_\_\_\_\_”

## **2.0 Authority**

By the authority granted in NH RSA 674:16 and 674:21 and in the interest of public health, safety, and general welfare of the Town of \_\_\_\_\_, the Wetlands Ordinance is hereby established.

## **3.0 Purpose and Intent**

The purpose of this Ordinance is to protect and regulate the use of wetlands and their buffer areas, as defined herein.

The intent of this ordinance is to:

- A. Insure the protection of wetland resources from activities that would adversely affect their functions and values, including but not limited to the following:
  - 1. Prevent damage of property and degradation of surface and groundwater by maintaining the capacity of wetlands to receive stormwater and minimize flooding events;
  - 2. Prevent or minimize soil erosion and the subsequent sedimentation of wetlands and surface waters ;
  - 3. Prevent the loss of unique and unusual natural areas associated with wetlands and surface waters;
  - 4. Prevent the degradation of surface and ground water quality within and adjacent to wetlands;
  - 5. Prevent the degradation of potential surface and ground drinking water supplies as well as existing aquifers and their recharge areas;
  - 6. Prevent the loss or degradation of wetland wildlife populations and protect their habitats both within wetlands and the immediate buffer zone of wetlands;
  - 7. Prevent the loss or degradation of a diversity of recreational benefits in wetlands such as hunting, fishing, canoeing, bird watching, and hiking;
  - 8. Prevent the loss of the visual and aesthetic qualities of wetlands including their contribution to open space, character, and overall scenic beauty of the landscape.
  
- B. Insure the protection of wetland buffer areas from activities that would adversely affect them, including but not limited to the following :
  - 1. Prevent erosion and sedimentation by stabilizing soil adjacent to wetlands and surface waters;
  - 2. Moderate the effects of stormwater runoff into wetlands and surface waters by filtering sediment, nutrients and harmful or toxic substances, and moderating thermal discharges;
  - 3. Protect and maintain wetland wildlife habitat in the buffer zone of wetlands and surface waters;
  - 4. Support and protect native vegetation in the buffer zone of wetlands and surface waters;
  - 5. Reduce the disturbances to wetland resources caused by intrusion of human activity in the buffer zone of wetlands and surface waters;

- C. Prevent the expenditure of municipal funds for the purposes of providing and or maintaining essential services and utilities that might be required as a result of the destruction or degradation of wetlands or surface waters.

#### **4.0 Definitions**

##### **Alteration**

Any change or modification of land, water, vegetation, or existing structure in a wetland and /or its buffer area.

##### **Authorized Agent**

A person designated by a municipal board to carry out the duties, functions, and purpose of said board

##### **Best Management Practices**

As promulgated by the state of New Hampshire, measures or practices used to minimize impacts on wetlands and water resources, such as those used to control erosion, reduce sedimentation, or prevent other forms of water quality degradation.

##### **Certified Soil Scientist**

A person who, by reason of his special knowledge of pedagogical principles acquired by professional education and practical experience, as specified by RSA 310-A: 84(I), is qualified to practice soil science, and who has been duly certified by the State Board of Natural Scientists.

##### **Certified Wetland Scientist**

A person who, by reason of multi-disciplinary expertise in wetland science acquired by professional education and practical experience, as specified by RSA 310-A: 84(II-a), is qualified to practice wetland science, and who has been duly certified by the State Board of Natural Scientists.

##### **Contiguous**

Immediately adjacent to; or, in the case of surface water or wetlands, hydrologically connected in a direct and proximal way – i.e. damage or degradation to one resource will likely cause damage or degradation to the contiguous resource.

##### **Drainageway**

The channelized extent of flowing water such as a river or stream, plus the adjacent upland banks that define maximum water levels during a flood event.

##### **Dredge**

To dig, excavate, or otherwise disturb the contour or integrity of sediments in the bank or bed of a wetland or surface water body.

##### **Hydric Soils**

Soils that are saturated, flooded or ponded long enough during the growing season to develop anaerobic conditions in the upper part, as defined by the USDA Soil Conservation Service, National Technical Committee for Hydric Soils.



**Hydrophytic Vegetation**

Plant life growing in water or on a substrate that is at least periodically deficient in oxygen as a result of inundation and/or saturation.

**Mean High Water Mark**

Also “ordinary high water mark,” or “natural mean high water level,” the highest average level of water in certain wetlands and most surface water bodies, as evidenced by water marks on trees or rocks, the limit of natural, upland vegetation along a shoreline, or the lower edge of floodwater debris. [Note: for state-designated “great ponds,” synonymous with “reference line.” See: <http://www.des.state.nh.us/cspa/faqs.htm#reference> or <http://www.des.state.nh.us/Dam/DamRemoval/NMHW.pdf> ]

**Pollution**

The contamination or alteration of the physical, biological, or chemical properties of wetland or water resources from the discharge or deposition of any waste or other materials. This includes, but is not limited to, sewage and sediment.

**Poorly Drained Soils**

Soils in which water moves so slowly that the water table remains at or near the ground surface for a large part of the year (6-9 months) as defined by the National Cooperative Soil Survey.

**Prime Wetlands**

Wetlands that are of substantial significance to society due to their “size, unspoiled character, fragile condition, or other relevant factors,” and which have been designated as Prime Wetlands under RSA 482-A:15.

**Special Use Permit**

A permit that may be granted by the Planning Board for a use not otherwise permitted under the Wetlands Ordinance.

**Surface Waters**

“Waters of the state,” as defined by RSA 482A:4, which have standing or flowing water at or above the surface of the ground. This includes but is not limited rivers, streams, lakes, and ponds.

**Toxic and Hazardous Materials**

Any materials and/or substances that are regulated under the NH Solid Waste Rules, Administrative Rules Env-Ws 100-300 and Env-Ws 2100-2800 administered by the NH DES Waste Management Division.

**Vernal Pool**

An ephemeral body of water that is typically isolated from other wetlands or surface waters, lacks fish and supports a specialized suite of amphibians and invertebrates. Documentation of the presence of a vernal pool includes but is not limited to direct, on-site evidence of one or more of the following: 1) breeding wood frogs (*Rana sylvatica*); 2) breeding mole (*Ambystomid*) salamanders; 3) fairy shrimp.

**Very Poorly Drained Soils**

Soils in which water is removed from the soil so slowly that the water table remains at or on the ground surface for the greater part of the year (9-10 months) as defined by the National Cooperative Soil Survey.

### **Wetlands**

Those areas that are inundated or saturated by surface or groundwaters at a frequency and duration sufficient to support, and that under normal conditions do support, a prevalence of vegetation adapted for life in saturated soil conditions. Wetlands generally include, but are not limited to, swamps, marshes, bogs, and similar areas.

### **Wetland Buffer**

An area adjacent to wetlands that, in its undisturbed and natural condition, is integral to the performance and protection of wetland functions and values.

### **Wetland Functions**

The capacity of a wetland to perform various services that benefit society and/or the natural ecosystem surrounding the wetland. Wetland functions include but are not limited to the following:

- 1) Ecological Integrity
- 2) Wildlife Habitat
- 3) Groundwater Recharge/Discharge
- 4) Sediment & Toxicant Removal & Attenuation
- 5) Floodwater Storage & Dissipation of Erosive Forces
- 6) Production Export
- 7) Education/Scientific Research
- 8) Visual & Aesthetic Quality

### **Wetlands Hydrology**

In general terms, permanent or periodic inundation or soil saturation sufficient to create anaerobic conditions in the upper part of the soil and support hydrophytic vegetation.

## **5.0 Wetlands**

### **5.1 Delineation of Wetland Boundaries**

- A. Wetlands shall be delineated on the basis of hydrophytic vegetation, hydric soils, and wetland hydrology in accordance with the techniques outlined in the Corps of Engineers Wetlands Delineation Manual, Technical Report Y-87-1, (January 1987).
- B. Delineation based on hydrophytic vegetation or hydric soils alone shall be sufficient for minimum impact projects as defined by RSA 482-A, provided that the vegetation or soil has not been disrupted by artificial planting or past alterations.
- C. The hydric soils component of a delineation produced under A or B above shall be determined in accordance with the manual, Field Indicators for Identifying Hydric Soils in New England

(Version 3, June 2004, or later version), published by the New England Interstate Water Pollution Control Commission.

## **5.2 Wetlands Incorrectly Delineated**

- A. Where it is determined that an area has been incorrectly delineated as a wetland or that an area not so designated was subsequently found to meet the criteria for wetlands designation, the Planning Board shall determine whether the regulations contained herein apply.
- B. The Planning Board shall make its judgment under this section upon the determination by a qualified soil or wetland scientist on the basis of additional on-site investigations or other suitable research. This evidence shall be acceptable only when presented in written form to the Planning Board. Any investigation or study deemed necessary by the Planning Board shall be conducted at the expense of the landowner, applicant or developer.
- C. The Planning Board and Conservation Commission may accept the comments, evidence, or testimony of any other qualified individual, agency, or organization as is reasonably offered in the course of its review.

## **6.0 Buffers**

### **6.1 Wetland Buffers**

- A. Buffer areas shall be required for all wetlands. All buffers shall be measured at a horizontal distance from the wetland boundary. The width of the wetland buffer shall be 100 feet, from the boundary of all wetlands contiguous to surface waters. For isolated wetlands that are not contiguous to surface waters, the width of the wetland buffer shall be 25 feet. The latter shall not apply to documented vernal pools, whose buffer area shall be the immediate sub-watershed of the vernal pool, and in all cases a distance of at least 100 feet from the mean high water mark of the vernal pool.
- B. Wetland buffers shall be retained in their natural condition. Where wetland buffer disturbance has occurred during construction, regrading to original contours and revegetation shall be required.

### **6.2 Surface Water Buffers**

- A. Buffer areas shall be required for all surface water bodies. All buffers shall be measured at a horizontal distance from the mean high water mark for lakes and ponds, and from the “top of bank” for rivers and streams, as defined by the NH Department of Environmental Services. The width of the buffer for surface water bodies shall be as follows:
  - Intermittent streams    25 feet
  - Perennial streams        100 feet
  - 4<sup>th</sup> order streams        150 feet
  - Lakes                        150 feet
  - Ponds                        100 feet
  - Vernal pools               100 feet, or limit of immediate sub-watershed, whichever is larger

- B. Surface water buffers shall be retained in their natural condition. Where surface water buffer disturbance has occurred during construction, regrading to original contours and revegetation shall be required.

## **7.0 Permitted Uses**

With exception of A, B and G in association with Prime Wetlands, the following uses are permitted in all wetlands and wetland buffers provided that (a) they are consistent with the purposes and intent of this ordinance; (b) they do not involve the erection or construction of a building or structure; (c) they do not involve the grading or recontouring of the land; (d) no draining, dredging, filling or change in the flow of water will result; and (e) the activity will not result in the pollution of wetlands, surface water, or groundwater.

- A. Logging operations which (a) utilize best management practices as described in Best Management Practices for Erosion Control on Timber Harvesting Operations in NH; (b) comply with all applicable state laws including but not limited to: obtaining and filing an intent to cut form according to RSA 79:10 and filing a complete Notification of Forest Management Activities Having Minimum Wetlands Impact according to RSA 482-A.
- B. Agricultural activities and operations as defined in NH RSA 21:34a and as governed by RSA 430, provided such activities and operations are in conformance with the most recent best management practices determined by the US Department of Agriculture Natural Resource Conservation Service, the NH Department of Agriculture, and/or UNH Cooperative Extension.
- C. Outdoor recreational activities including hunting, hiking, fishing, swimming, and boating.
- D. Wildlife or fisheries management activities;
- E. Educational activities and scientific research
- F. Conservation of open space
- G. Activities incidental to normal ground maintenance around a residence, including mowing, trimming of vegetation and removal of dead or diseased vegetation, In the state-recognized shore land district, said maintenance shall be subject to the restrictions of RSA 483-B, the Comprehensive Shoreland Protection Act, as amended.. This shall not include the regrading or recontouring of land or the clearing of vegetation.

No person shall conduct or maintain other uses without first obtaining a Special Use Permit.

## **8.0 Prohibited Uses**

- A. The establishment or expansion of:
  - 1. salt storage sheds;
  - 2. automobile junk yards;
  - 3. solid or hazardous waste facilities;
- B. The bulk storage of chemicals, petroleum products, or toxic and hazardous materials;

## **9.0 Uses Requiring a Special Use Permit**

The following uses in Wetlands and Wetland Buffers require a Special Use Permit:

- A. Activities that alter or remove soils or vegetation including, but not necessarily limited to, land clearing, dredging, draining, or filling.
- B. Activities that alter the natural drainage system resulting in a change in the flow of water, water level or water table.
- C. The construction or alteration of structures, streets, roads, and other access ways and utility right-of-way easements, including powerlines and pipelines.
- D. Water impoundments for the purpose of creating a waterbody for wildlife, on-site detention of stormwater runoff and/or recreational uses.
- E. Timber harvesting and agricultural activities as described in Section 7.0 above that occur inside of or within 100 feet of a designated Prime Wetland
- F. The undertaking of a use not otherwise permitted in wetlands or wetland buffer areas that is permitted in the underlying zoning district, if it can be shown that such proposed use is not in conflict with any and all of the purposes and intentions listed in Section 3.0 of this ordinance.

## **10.0 Standards for Granting a Special Use Permit**

### **10.1 Administration**

- A. The Planning Board shall be responsible for the administration of the Special Use Permit. The Planning Board shall hold at least one public hearing after sufficient public notice during the Special Use Permit review. The application shall be referred to the Conservation Commission for review and comment at least 30 days prior to the public hearing. The Planning Board shall review the application within 90 days of the public hearing, unless the applicant and the Planning Board agree to an extension for a set period of time.
- B. Any person found to be conducting or maintaining an activity without the prior authorization of the Planning Board, or violating any other provision of this ordinance, shall be subject to the enforcement proceedings and penalties prescribed in section 11.0 of this ordinance and any other remedies provided by law.
- C. If granted, the Special Use Permit shall be valid for a period of two years from the date of issue and shall expire if not implemented by that time, unless a longer period is specified and approved by the Planning Board in consultation with the Conservation Commission.

## **10.2 Application Requirements**

Applications for a Special Use Permit shall include the following:

A. Site Plan at a scale of 1"=100' or larger indicating the following:

1. Lot or lots of record to be impacted;
2. Names and addresses of abutting property owners;
3. Wetlands delineation, and name of person(s) or agency performing said delineation;
4. Shading and computation of the area to be impacted;
5. Soil type(s) (in accordance with Site Specific Soil Mapping Standards for New Hampshire and Vermont (June 1997, as amended), within NCSS mapping standards developed by the USDA Soil Conservation Service in Cooperation with the Soil Society of Northern New England.);
6. Vegetation types;
7. Location of all drainageways and surface water bodies in vicinity of project area;
8. Other significant natural features;
9. Proposed land use/activities, including stormwater management structures as needed;

B. Project report including the following:

1. USGS topographic map showing location of proposed impact area
2. Photographs mounted on 8.5 x 11" white paper of proposed impact area
3. Description of the ecological communities;
4. Description of wetland functions;
5. Effects of the impact on the wetland and its functions;
6. Measures taken to minimize the impact;
7. Proposed land use/activities, sediment and erosion control plan, and monitoring and mitigation plan as required by the NH Department of Environmental Services;

The site plan submitted for a subdivision or site plan review application to the Planning Board is acceptable if it meets all of the above requirements.

## ***11.0 Enforcement***

- A. The Planning Board is hereby authorized and empowered to adopt such rules and require such reasonable fees as are necessary for the efficient administration of this ordinance.
- B. The Selectmen or their appointed agent shall be responsible for enforcement of the provisions of this ordinance.
- C. Upon any well founded information that this ordinance is being violated, the Planning Board or Conservation Commission shall report the violation to the Selectmen. Upon receipt that this ordinance is being violated, the Selectmen or their appointed agent shall notify, in writing, the owner or tenant of the property on which the violation is alleged to occur with a copy of such notification to the Planning Board and Conservation Commission. If appropriate, the Selectmen shall also notify the NH Wetlands Bureau, U.S. Army Corps of Engineers, the U.S. Environmental Protection Agency, or such other State or Federal Agency as may have jurisdiction of the violation.
- D. Any person in violation of this ordinance or portion thereof shall be penalized in accordance with NH RSA 676:15-17.

## ***12.0 Conflict with Other Regulations***

Where any provision of this ordinance is in conflict with any other municipal ordinance, or state or Federal regulation, the more stringent provision shall apply.

## ***13.0 Special Provisions – Prime Wetlands***

By virtue of the “size, unspoiled character, fragile condition, or other relevant factors,” according to RSA 486-A:15, and the findings of the 2005-2007 *Wetlands Inventory and Protection Project* sponsored by the \_\_\_\_\_ Conservation Commission and funded in part by the State Conservation Committee (“Moose Plate”) Grant Program, the following wetlands in the Town of \_\_\_\_\_ are designated as Prime Wetlands:

**Ossipee Watershed Coalition**  
**Natural Resources Planning Guide**  
**Chapter V – C Contiguous Open Space and Wildlife Habitat**

**I. Introduction: Why the Resource is Important**

Wildlife habitat conservation actions provide many societal benefits, such as, clean air and water, species diversity, sustainable economic growth, protection of flood retention areas, and preserving the rural character of New Hampshire. The New Hampshire Wildlife Action Plan (WAP), which was mandated and funded by the federal government, identifies statewide strategies for identifying, restoring and maintaining critical habitats and populations of wildlife species of conservation and management concern. The WAP is the most comprehensive statewide wildlife assessment to date, and was completed by dozens of wildlife experts from conservation agencies, organizations, and academic institutions. It is a pro-active effort to define and implement a strategy that will help restore and maintain critical habitats and populations of the state's species of conservation and management concern.

**II. Description of the Resource**

Wildlife habitats initially selected for inclusion in the WAP reflect habitats for priority wildlife species (Figure 1). The Ossipee Watershed encompasses some of the highest ranked wildlife habitat by condition in the State of New Hampshire but falls below the statewide town-average for percent in conservation (Table 1).

The watershed is home to a third of the state's wildlife species of conservation concern:

[http://www.wildlife.state.nh.us/Wildlife/Wildlife\\_Plan/WAP\\_pieces/WAP\\_Chapter\\_2.pdf](http://www.wildlife.state.nh.us/Wildlife/Wildlife_Plan/WAP_pieces/WAP_Chapter_2.pdf)

A list of species, by town, is available from NH Natural Heritage Inventory:

<http://www.dred.state.nh.us/divisions/forestandlands/bureaus/naturalheritage/listsforms.htm>

(Publication: Rare Plants, Rare Animals, and Exemplary Natural Communities in New Hampshire Towns)

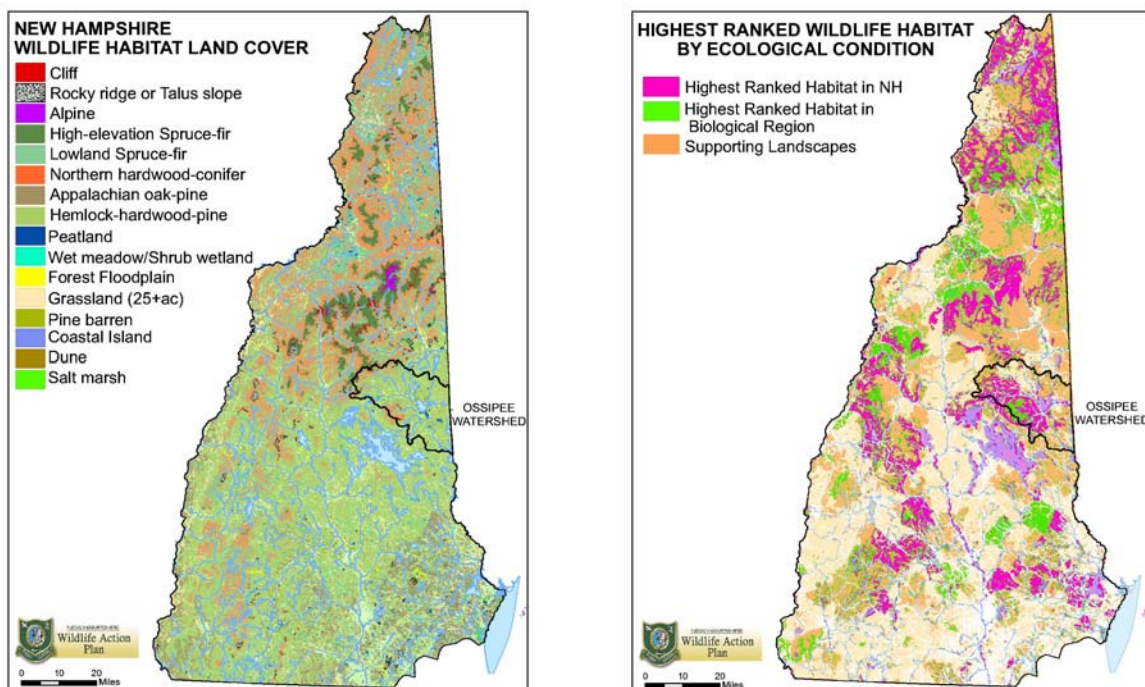

**Chapter V-C Figure 1.** Wildlife habitat mapped and ranked in the NH Wildlife Action Plan.



**Chapter V-C Table 1.** Summary of top-ranked wildlife habitat by ecological condition (NH Wildlife Action Plan spatial data - October 2006)

TOWN	Total Acres	Land Acres	Tier 1 = Highest Ranked Wildlife Habitat in New Hampshire				Tier 2 = Highest Ranked in Biological Region			Tier 3 = Supporting Landscape		
			Tier1 Acres	% Town Area	Tier1 acres conserved	Tier1 percent conserved	Tier2 Acres	Tier2 acres conserved	Tier2 percent conserved	Tier3 Acres	Tier3 acres conserved	Tier3 percent conserved
Effingham	25,556	24,827	7,788	30.5%	2,668	34.3	768	372	48.4	14,878	2,143	14.4
Freedom	24,262	22,058	8,058	33.2%	884	11.0	1,811	104	5.7	13,669	1,090	8.0
Madison	26,157	24,647	4,999	19.1%	729	14.6	406	48	11.8	15,426	1,447	9.4
Ossipee	48,168	45,079	31,386	65.2%	6,421	20.5	1,767	487	27.6	14,078	1,433	10.2
Sandwich	60,251	58,166	36,666	60.9%	8,278	22.6	1,650	280	16.9	10,153	5,439	53.6
Tamworth	38,813	38,121	16,209	41.8%	5,003	30.9	5,187	2,150	41.4	5,864	2,821	48.1
<b>OWC Town average</b>				<b>41.8%</b>		<b>22.3</b>			<b>25.3</b>			<b>23.9</b>
<b>State average</b>				<b>32.5%</b>		<b>27.4</b>			<b>26.3</b>			<b>25.2</b>

Note: WAP habitat land cover and ranking by ecological condition includes aquatic habitat (open water).  
Sum of tiers may exceed the land area but will not exceed to total area of the town.

From a terrestrial habitat perspective, ecoregions and subsections for New Hampshire were developed through the NH Ecological Reserve Systems Project, and derived from original work done by the U.S. Forest Service. Based on broad geologic, climatic, and landform characteristics, the Ossipee Watershed is within the Sebago-Ossipee Hills & Plains ecoregion subsection. The subsection boundaries reflect how natural communities show affinity for different suites of abiotic factors.

### III. Current and Potential Threats to Wildlife Habitat

#### A. Habitat Fragmentation.

Large tracts of contiguous open space contain a mix of habitat types valuable to wildlife. Development of land and related land use activities associated with increase in human population are impacting these unfragmented lands. The conversion of open space affects quality of wildlife habitat to an extent beyond the development footprint (Table 2). Changes to environmental conditions and animal behavior along edges of disturbance reduce the amount of interior habitat essential to some wildlife species. Affect of habitat fragmentation to forest ecosystems and their associated biodiversity is summarized in the unpublished report “Integrated Fragmentation Effects Surface for the State of New Hampshire” (The Nature Conservancy to NH Fish and Game Department, August 2005).

Edge effects can include:

- 1.) alteration of physical environment that changes vegetation structure and composition
- 2.) creation of a disturbed environment that may serve as a vector for invasive plants
- 3.) provide greater opportunity for predators (raccoons, foxes, crows) and brood parasitizers (cowbirds) utilizing new forest edges
- 4.) provide vehicle access and increasing recreational impacts
- 5.) increased distances between habitat patches

**Chapter V-C Table 2.** Distance from edge categories

Distance from Edge Range	Likelihood of Edge Effects	Magnitude/# of Edge Effects on wildlife species
0-15 meters	Very High	Many/All Known
15-60 meters	High	Many (e.g., abiotic, bird, mammal, macroinvertebrate, vegetation)
60-100 meters	Medium	Many
100-300 meters	Medium-Low	Moderate
300-900 meters	Low	Few (some large mammals)

Wildlife species differ in their requirements for uninterrupted living space (for examples, see Table 3). Minimizing fragmentation of forested habitat from development will benefit species such as fisher, who regularly travel 10-20 square miles and require mature forests with structural diversity. Adult male black bears may range up to 120 square miles, while females range over a smaller area, about 10 square miles. Black bear are best suited to large forested areas with a mix of wetlands, thick understory vegetation, and a diverse source of food including beechnuts, acorns, berries, and other mast. Preferably, these areas are relatively undisturbed by humans and are unfragmented by roads. In the mid-1800’s fewer than 15 moose existed in the state. A mosaic of mature and young re-growing forests interspersed with wetlands provides excellent moose habitat, with patch size requirements varying from 1 to 25 square miles, depending on the season.

Recommendation: Following development practices and forest management strategies listed in the Resources section below will help maintain habitat for species requiring large tracts of contiguous open space.

**Chapter V-C Table 3.** Unfragmented Habitat Size Classes: (NH Fish and Game Department 2005)

<b>Size (Acres)</b>	<b>Description</b>
25–99 Ac	25 Ac = minimum size for breeding pair of whip-poor-wills
100–499 Ac	100 Ac = minimum habitat patch size for red-shouldered hawk; 80 & 100 males/100Ac = recorded sample densities of bay-breasted warbler; 247 Ac = recorded home range of spruce grouse; area that 90% of occurrences of veery were recorded in studies in Wisconsin/Illinois; area for a viable population of wood thrush
500–999 Ac	560 Ac = 50% probability of occurrence for red shouldered hawk; 500 Ac = approx. max. dispersal area for wood, spotted, or Blanding’s turtle based on max. recorded dispersal distance of 2.05 km
1,000–3,999 Ac	1,200 Ac = minimum recorded home range for northern goshawk; 1,280 Ac = male marten home range in Maine; 1,320 Ac = max. home range recorded for Cooper’s hawk; 2,500 Ac = area for 25 territorial Whip-poor-will males
4,000–9,999 Ac	3,900–6,144 Ac = minimum home ranges recorded for Lynx in four studies; 9,400 Ac = area required for breeding pair of northern goshawks

From an aquatic habitat perspective, the Ossipee Watershed is included in the “Coastal Transition” watershed group in the WAP as defined by watershed scale aquatic ecological features. This New Hampshire portion of the larger Saco River Watershed encompasses the acidic sandy outwash plains of the Ossipee and Little Ossipee headwaters. Further description of the Coastal Transition watershed group is available in Chapter 2, Habitat Profiles, pp. 91-98 in the WAP.

Early studies (1930’s) documented the occurrence of natural brook trout waters in the Saco River watershed. “Wild Brook Trout Management in New Hampshire Streams: A Program Overview” (NHFG 2001) lists several priority tributaries to the Bearcamp River as potential candidates for wild trout (i.e., brook trout, brown trout, and rainbow trout) management. Inventories of the fish habitat and fish communities in Wonalancet and Whiteface Rivers were conducted during the summers of 2003 and 2005. The objectives of the survey were to: 1) document the quality and quantity of coldwater fish habitat and fish populations; and 2) document areas of natural or human induced aquatic habitat degradation. Information collected for each habitat unit included dominant substrate composition, percent instream cover, dominant instream cover type, percent canopy cover, area of spawning gravel, dominant riparian vegetation, and amount of streambank erosion. Fish population sampling was conducted using electrofishing gear. The calculated biomass of wild trout was above the established criteria, establishing these rivers as candidates for active wild trout management at this time.

Recommendation: To maintain populations of wild trout, careful land use planning (see Resources section below), including application of best management practices to reduce non-point source pollution and mitigate other indirect effects of development will be required.

#### **IV. Recommendations**

At the town level, protection occurs in reference to regional plans, but could be refined by local wildlife habitat monitoring and comprehensive natural resource inventories. Areas identified through these efforts can then be protected through landowner incentives, zoning ordinances and regulatory measures. Habitat and species profiles in the NH Wildlife Action Plan outline what needs to be done to conserve wildlife species and critical habitats into the future, but success of implementing those prescriptions will largely depend on you.

#### **V. Helpful Hints / Links / Resources**

**Wildlife Habitat Management** Draft chapter from: Innovative Land Use Planning Techniques  
[http://www.des.nh.gov/REPP/ilupth/Habitat\\_Protection.doc](http://www.des.nh.gov/REPP/ilupth/Habitat_Protection.doc)

To address the need for guidance and technical assistance on Innovative Land Use Controls authorized by [RSA 674:21](#), the New Hampshire Regional Environmental Planning Program (REPP) is producing a guide with model ordinances and regulations on a number of innovative land use techniques. Clickable links are provided for chapters in final draft form available for use in New Hampshire towns. Please note that chapter layout and graphics may not be complete. For more information or comments on the content of these chapters, contact Eric Williams at N.H. Dept of Environmental Services, [ewilliams@des.state.nh.us](mailto:ewilliams@des.state.nh.us) (603) 271-2358.  
<http://www.des.nh.gov/REPP/index.asp?go=ilupth>

Habitat Sensitive Site Design and Development Practices to Minimize the Impact of Development on Wildlife. 2004. NH Department of Environmental Services. Environmental Fact Sheet  
<http://des.nh.gov/factsheets/id/id-4.htm>

NH Natural Heritage Bureau. 2007. Rare Plants, Rare Animals, and Exemplary Natural Communities in New Hampshire Towns.  
[http://www.dred.state.nh.us/divisions/forestandlands/bureaus/naturalheritage/documents/web\\_towns\\_001.pdf](http://www.dred.state.nh.us/divisions/forestandlands/bureaus/naturalheritage/documents/web_towns_001.pdf)

New Hampshire Wildlife Action Plan. October 2005. NH Fish and Game Department, in cooperation with conservation partners.  
[http://www.wildlife.state.nh.us/Wildlife/wildlife\\_plan.htm](http://www.wildlife.state.nh.us/Wildlife/wildlife_plan.htm)

#### **VI. References:**

---

New Hampshire Fish and Game Department, Inland Fisheries Division. 2001.  
Wild Trout Management in New Hampshire A Program Overview. 5 pp.  
Habitat Assessment and Trout Abundance in the Bearcamp River Watershed: Wonalancet and Whiteface Rivers July 1, 2005 – June 30, 2006

The Nature Conservancy. 2005. Unpublished reports to the NH Fish and Game Department in support of the NH Wildlife Action Plan.

VII. Sample Town Model Ordinance provided by Division of Environmental Services  
<http://www.des.nh.gov/repp/index.asp?go=ilupth>.

# WILDLIFE HABITAT MANAGEMENT

- Draft Chapter From: *Innovative Land Use Planning Techniques* -

*Related Tools in Innovative Land Use Planning Techniques: Conservation Subdivision, Transfer of Density Rights, Village Plan Alternative Development.*

## Background and Purpose

Wildlife and wildlife habitat provide many public benefits and serve important ecological functions. Important ecological services are often provided by particular wildlife habitats, which may serve as buffers to streams, flood retention areas, areas of carbon sequestration, and filters of environmental contaminants. Diversity of plant and animal life contributes to the versatility and long-term health of the food supply and the ecosystem as a whole.

Protecting wildlife and their habitat also contributes to the rural character of New Hampshire, as hunting, fishing, and wildlife watching are long-standing features of the culture and attract tourism to a rural area.

**Habitat protection can occur at three levels: regional, town master planning, and site planning. Habitat protection can be accomplished with regulatory, market-based or voluntary measures.** This chapter deals with regulatory measures.

## Appropriate Circumstances and Context for Use

Ideally, protection of wildlife habitat begins at the largest scale appropriate. This scale is determined through study of the range of the particular animal and the extent of its habitat across a multi-state and multi-regional area. Due to difficulties in coordinating across political boundaries and biological boundaries, most government entities must settle for either a coordinated approach with neighboring regions, or a regional-level approach that acknowledges that the range may extend beyond political boundaries.

The New Hampshire Wildlife Action Plan, which was mandated and funded by the federal government, identifies statewide strategies for identifying, restoring and maintaining critical habitats and populations of wildlife species of conservation and management concern. It is a pro-active effort to define and implement a strategy that will help keep species off rare species lists.

At the town level, protection occurs in reference to larger plans, but is refined by local wildlife habitat mapping and inventories. Town protection starts in the master planning process when areas are identified for protection through the use of natural resource inventories and maps. These areas can then be protected through zoning ordinances and regulatory measures.

The tool presented here can be used in three ways: as voluntary guidelines for developers, as a set of design principles adopted by a town or board, and finally, as a set of standards that could be incorporated into site plan and subdivision ordinances as performance standards.

## ***Legal Basis and Considerations for New Hampshire***

Protection of wildlife is referenced and or supported in the following RSA sections.

- **Environmental Characteristics Zoning. RSA 674:21:** Although not specifically defined, this provision gives planning boards the authority to adopt an innovative land use control based upon the environmental characteristics as shown in a local or regional natural resources mapping and inventory project. Examples of environmental characteristics could include aquifers, wetlands, unfragmented forest blocks, or specific habitat types such as grasslands or forest types.
- **Village Plan Alternative Subdivision. RSA 674:21:** This section defines village plan alternative as “an optional land use control and subdivision regulation to provide a means of promoting a more efficient and cost effective method of land development. The village plan alternative’s purpose is to encourage the preservation of open space and more efficient use of land.”
- **Master Plan; Purpose and Description RSA 674:2:** This section states that a master plan may include the following section: (subpart (d)) “a natural resources section which identifies and inventories any critical or sensitive areas or resources, not only those in the local community, but also those shared with abutting communities. This section provides a factual basis for any land development regulations that may be enacted to protect natural areas.”
- **Subdivision Regulations. RSA 674:36l(l) and (m):** This section gives the planning board the authority to adopt a subdivision regulation which “provide for efficient and compact subdivision development that promotes retention and public usage of open space and wildlife habitat, by allowing for village plan alternative subdivision” and “require innovative land use controls on lands when supported by the master plan.”
- **Comprehensive Shoreland Protection Act. RSA 483-B:2:** This section states that the standards set forth in the chapter shall serve to “protect fish spawning grounds, aquatic life, and bird and other wildlife habitats” and “promote wildlife habitat, scenic beauty, and scientific study.”
- **Rivers Management and Protection Program. RSA 483:6:** This section provides a process for any New Hampshire organization or resident to nominate a river or segment of a river for protection by submitting a description of the river and its values and characteristics, including “an assessment of fisheries ... vegetation, and ... wildlife. And provides standards for classification and management of rivers.”

### **Examples and Outcomes Where Technique Has Been Applied**

Many New Hampshire towns have completed wildlife habitat inventories to guide the work of town boards. Belmont has adopted statements of purpose in its master plan language to guide the creation of ordinances and regulations to carry out the purpose of protection of wildlife. Rye includes discussions of wildlife and habitat and the need to protect such resources in its natural resources chapter of the master plan.

In addition to comprehensive regulations, as presented here, a town may wish to focus on a particular wildlife species and habitat that may be found locally or may be identified in New Hampshire's Wildlife Action Plan. A town may also wish to deal with particular impacts of development and put in place strategies to address those impacts, such as regulations to limit allowable tree clearing for new development or require vegetated buffers of streams to protect riparian area habitat.

## ***Model Language, Illustrations and Guidance for Implementation***

### **Habitat Sensitive Site Design and Development Practices**

These practices may be used in three ways:

- 1) As an educational tool for citizens and developers to encourage voluntary practices for habitat sensitive site design.
- 2) As a checklist for conservation commissions and planning boards in reviewing applications and suggesting voluntary alternative site designs and development practices at the planning stage.
- 3) As elements of a performance zoning ordinance that awards density bonuses or requires compliance with the checklist items as a condition of subdivision approval.

A pre-application review meeting between the developer and planning staff to discuss the checklist elements is strongly encouraged.

## **MODEL LANGUAGE FOR SUBDIVISION AND SITE PLAN REVIEW REGULATION AND CHECKLIST**

### **I. PURPOSE**

The purposes of this section are:

- A.** To protect and maintain the natural environment.
- B.** To provide for green spaces of adequate proportions.
- C.** To provide a habitat for wildlife.
- D.** To minimize soil erosion, lessen air pollution, conserve energy, and protect the quality of groundwater.
- E.** To provide for the harmonious and aesthetically pleasing development of the municipality and its environs.
- F.** To protect the public benefits of habitat protection, including flood control, water recharge, carbon sequestration, food web integrity, and nutrient cycling.

### **II. APPLICABILITY**

This regulation applies to all applications for new development requiring site plan review and applications for the subdivision of land.

**Margin Note: Option: A municipality might choose to limit the applicability of these requirements to certain areas of the community (e.g., an overlay zone consisting of those areas identified as important habitat within a natural resource inventory or open space plan) or to parcels of a certain size (e.g., any parcel greater than 10 acres). An overlay zone would be established through a separate zoning action.**

### **III. AUTHORITY**

- A. RSA 674:16 II. Subdivision Regulations.** The power to adopt a zoning ordinance under this subdivision expressly includes the power to adopt innovative land use controls which may include, but which are not limited to, the methods contained in RSA 674:21.
- B. RSA 674: 21 (j). Innovative Land Use Controls/ Environmental Characteristics.** An innovative land use control to protect specific natural resources or features based on scientific evidence and community input may be adopted under RSA 674:21 when supported by the master plan and contains within it the standards that shall guide the person or board which administers the ordinance.
- C. RSA 674: 21(h) Innovative Land Use Controls/ Performance Standards.** An innovative land use control to control the physical characteristics and operations of a proposed use may be adopted under RSA 674:21 when supported by the master plan and contains within it the standards and criteria against which the development will be evaluated.
- D. RSA 674: 17 (h) and (i) Purposes of Zoning Ordinances.** To assure proper use of natural resources and other public requirements and to encourage the preservation of agricultural lands and buildings.

### **IV. FINDINGS AND PRINCIPLES**

It is the finding of this board that, in order to achieve the purposes above, the following principles will significantly enhance the protection of wildlife habitat at the site level and contribute to the protection of habitat at the watershed and regional level by:

- Maintaining the ability of ecological systems to provide ecosystem functions necessary to maintain wildlife habitat and the multiple benefits to wildlife and humans provided by such habitat.
- Maintaining unfragmented habitat blocks.
- Connecting habitat patches, facilitating wildlife movement through the area.
- Protecting wildlife from the negative impacts of development, including not only negative impacts to the habitat itself, but also to animal behavior and life cycle activities.
- Requiring site-specific habitat assessment and other practices described more fully below to protect wildlife from the negative impacts of development.

### **V. DEFINITIONS**

**Deer Wintering Area** – An area used by deer during winter for shelter. Also called a deer yard. Deer wintering areas are typically comprised of dense softwood cover with a crown closure greater than 60 percent.



**Habitat** – An organism’s home, including the area used in all parts of its life cycle, such as feeding, breeding, egg laying, or bearing young.

**Mast Stand** – An area of woody plants, such as oak, hickory, beech, maple, and various pines, that produce dry fruit (mast), which is a food source for a variety of mast-dependent wildlife such as deer, turkey, and squirrels.

**Openness Ratio** – Calculated by dividing a culvert’s cross-sectional area by its length (OR = x-sec area ÷ length).

**Riparian** – Related to or adjacent to a stream or watercourse, or having a high water table because of proximity to an aquatic ecosystem or subsurface water. Although originally associated with rivers and streams, this term is now also sometimes used to describe wetland areas not necessarily associated with rivers or streams.

**Vernal Pool** – A confined basin depression that is covered by shallow water usually for at least two months in the late winter, spring, and summer, but may be dry during much of the year.

**Wetland** – An area that is inundated or saturated by surface or ground water at a frequency and duration sufficient to support and that under normal conditions does support, a prevalence of vegetation typically adapted for life in saturated soil conditions. Wetlands include, but are not limited to, swamps, marshes, bogs and similar areas.

## **VI. HABITAT-PROTECTION SITE PLAN AND SUBDIVISION REVIEW CHECKLIST**

The following checklist shall be utilized in the review of all site plan and subdivision applications. The board shall determine, on a case-by-case basis, and as applicable, whether the applicant’s proposed development is consistent with these principles:

- A. Does the applicant conserve rare and outstanding landscape features, including unique or critical habitats, by directing development to other areas?**  
YES \_\_\_\_\_ NO \_\_\_\_\_

**Required action:**

- Conduct a site assessment of existing resources, identify areas for protection and associated buffers, and demonstrate methods that will be utilized for protection in the construction sequence section of the plan set.
- Development is directed away from habitat types that are rare statewide or to a particular geographic region.
- Development should be directed away from salt marshes, riparian areas, vernal pools, emergent wetlands, large wetland complexes (i.e., wetlands greater than five acres or clusters of wetlands), south-facing slopes, open fields, agricultural lands, and mast stands.
- Building envelopes are specified to control the location of future development.
- Avoid locating roads within or near important habitat or forage areas such as mast stands, deer wintering areas, or vernal pools.

**B. Does the applicant maintain significant buffers of undeveloped land between important habitat areas and developed area?**

YES \_\_\_\_\_ NO \_\_\_\_\_

**Required actions:** Applicant must maintain appropriate buffers for the protection of habitat areas on the parcel as follows:

- Maintain vegetated buffers for wetlands and surface waters including riparian buffer areas. The most effective buffer strips will consist of a series of vegetation of different heights beginning with a grassy strip graduating to a strip of shrubs, and ending with a forested strip along the stream bank. The multiple series approach provides multiple benefits including stream bank stabilization. A generally accepted width for a buffer for wildlife habitat is 300 feet; for water quality, a buffer of 50 to 100 feet is recommended for most situations. Where high sediment loads or steep slopes exist, the water quality buffer should be expanded about five feet for every 1 percent increase in slope. ( Connecticut River Joint Commission, 2000; J.C. Klapproth, 2000; Wenger, 1999; Hodgman, 2006).
- Maintain at least 200 feet of buffer from the perimeter of core areas of identified deer wintering areas.
- Maintain a minimum 300 feet of buffer from other significant habitat areas identified by the municipality, local or regional open space or habitat protection plan, or during site plan or subdivision plan review.
- Maintain a buffer of 400 feet around existing vernal pools and maintain a mostly closed canopy of trees within 100 feet of any vernal pool.
- Avoid construction of houses within 300 feet of important mast stands and avoid construction of paved roads within 200 feet of important mast stands.
- Avoid fragmentation of connecting areas between habitat areas and buffer areas.
- Mark areas of vegetated buffers and soft (graduated) edges of conservation areas with permanent monuments or signage indicating that the area is A NO CUT/ NO DISTURB VEGETATED BUFFER.

**C. Does the applicant identify and conserve wildlife corridors of a minimum width of 300 feet through the property to facilitate wildlife movement within and across developed areas?**

YES \_\_\_\_\_ NO \_\_\_\_\_

**Required action:**

- Conduct a site-specific wildlife assessment to identify appropriate corridors through a property or reference the town's Natural Resource Inventory or other local or regional assessment identifying appropriate corridors.
- Construct adequately sized underpasses or tunnels across roadways at known reptile and amphibian crossing sites and overpasses or underpasses across roadways along wildlife corridors.

**D. Does the applicant maintain the structure and function of aquatic systems?**

YES \_\_\_\_\_ NO \_\_\_\_\_

**Required actions:**

- Layout of development eliminates or minimizes stream and wetland crossings by roadways and driveways.

- Use a bridge span to cross river, streams or wetlands whenever possible.
- Bridge spans and culverts must have the following attributes:
  - Natural stream bottoms.
  - Sized for 1.2 x bank-full stream width (i.e., the width of the stream during the 1 and one-half year flow event) to reduce potential future erosion near bridge and culvert openings and allow for wildlife passage along the channel during most times of the year.
  - Bridges and culverts must have an openness ratio of  $\geq 0.25$  (calculated in meters) for perennial streams.
  - Passageways under roads should be designed to maintain water velocity at a variety of flows that is comparable to flows upstream and downstream segments of the natural stream.
  - Culverts should have a trough or narrow channel in the bottom running the full length of the culvert to maintain sufficient water depth during low-flow periods to support fish passage.
  - Round culverts must be imbedded at least 25 percent.
- Maintain a 300 foot vegetated buffer on either side of a stream crossing.
- Stormwater management practices are used to prevent the direct discharge of stormwater to aquatic systems, including wetlands and small streams.

**E. Does the applicant minimize the clearing, grading, and compaction of soil during construction activities?**

YES \_\_\_\_\_ NO \_\_\_\_\_

**Required actions:**

- Cut and fill is minimized, with the maximum height of any fill or depth of any cut area, as measured from the natural grade, not greater than 10 feet, and is preferably limited to four to six feet.
- Development follows the natural contours of the landscape to the maximum extent possible to minimize grading.
- The smallest feasible equipment is used during construction and every effort is made to minimize travel over the area.
- Soils are re-aerated after construction is complete and prior to seeding and landscaping.
- Provide for six to 10 inches of top soil post-construction to any areas previously disturbed prior to seeding and landscaping these areas.

**F. Does the applicant provide for the protection of vegetated buffers, stands of mature trees, and other vegetation to be preserved during and after construction?**

YES \_\_\_\_\_ NO \_\_\_\_\_

**Required actions:**

- Important mast stands and other vegetation to be protected during construction are clearly marked, including area out to the drip line of the tree.
- Not allow construction materials to be stored over the root zone of trees.
- Mark areas of vegetated buffers and soft edges of conservation areas with permanent monuments or signage indicating that the area is a no cut/ no disturb vegetated buffer.

- Submit a tree clearing plan, indicating areas of trees to be cleared, and areas to be protected, and retain, at the applicant's expense, a qualified natural resources professional to review the applicant's plan.

**G. Does the applicant attempt to mimic features of the local natural landscape in developed areas?**

YES \_\_\_\_\_ NO \_\_\_\_\_

**Required actions:**

- Maintain existing foliage height diversity, to provide a range of habitat through layers of vegetation, such as ground covers, shrubs, and trees.
- Minimize edge effects by creating soft edges between developed areas and conservation areas using a graduation of smaller shrubs to larger shrubs to small trees to larger trees.
- Utilize native, non-invasive species in landscaping.
- Minimize the amount of area per lot converted from existing vegetation to lawn.
- Provide a stormwater management approach that maintains the natural peak flow and total volume of flow off-site pre- and post-development by providing for best management practices that capture, treat, and infiltrate stormwater in smaller-scale management areas throughout the development.

**H. Does the applicant minimize the negative effects of development on wildlife and discourage human-wildlife conflicts by using such methods including but not limited to: directing light away from stands of trees, fencing gardens, pet food areas, and covering and fencing trash disposal areas?**

YES \_\_\_\_\_ NO \_\_\_\_\_

**Required actions:**

- The homeowners association's documents should include the specific measures that will be used to ensure that the development will minimize potential negative effects on wildlife and habitat, and that human-wildlife conflicts such as predation or nuisance animal incidents will be discouraged by ensuring that garbage, pet food areas, and small pets do not serve as a food source to area wildlife. The documents should also address landscaping and discourage the introduction of invasive species and excessive use of nitrates and phosphates.
- Some areas of the development near homes may require fencing or other measures to deter wildlife from gardens and yards.
- Lighting must be fully shielded and directed away from stands of trees or other habitat areas so as not to disrupt animal behavior.

**References**

Connecticut River Joint Commissions. 1998. Buffers for Habitat. Connecticut River Joint Commissions of NH and Vermont.

Duerksen, C.J. et al. 1997. Habitat Protection Planning. American Planning Association, PAS Report Number 470/471.

Duerksen, C.J. and S. Richman. 1993. Tree Conservation Ordinances. American Planning Association and Scenic America, PAS Report Number 446.

Hodgman, T.P. 2006. Riparian Zones: Managing Early-Successional Habitats Near the Water's Edge. Chapter 9 In: Managing Grasslands, Shrublands, and Young Forest Habitats for Wildlife: A Guide for the Northeast. Edited by Oehler, J.D., D.F. Covell, S. Capel, and B. Long. Northeast Upland Habitat Technical Committee, Massachusetts Division of Fisheries and Wildlife.

Kanter, J., R. Suomala and E. Snyder, with contributing authors P. Auger, C. Foss, J. McLaughlin and M. Tarr. 2001. Identifying and Protecting New Hampshire's Significant Wildlife Habitat: A Guide for Towns and Conservation Groups. Nongame and Endangered Wildlife Program of the New Hampshire Fish and Game Department.

Klapproth, J.C. 2000. Understanding the Science Behind Riparian Forest Buffers: Effects on Water Quality. Virginia Cooperative Extension Publication Number 420-151, available online at [www.ext.vt.edu/pubs/forestry/420-151/420-151.html](http://www.ext.vt.edu/pubs/forestry/420-151/420-151.html)

Maine Audubon Society. 2000. Conserving Wildlife in Maine's Developing Landscape.

New Hampshire Department of Environmental Services and New Hampshire Fish and Game Department. 2004. Habitat-Sensitive Site Design and Development Practices to Minimize the Impact of Development on Wildlife. Available online at: <http://des.nh.gov/factsheets/id/id-4.htm>

New Hampshire's Wildlife Action Plan. 2006. Available online at: <http://www.wildlife.state.nh.us>.

Rural Smart Growth Advisory Committee, with Assistance from Brunswick Planning and Development Department, Woodlot Alternatives, Inc., and Planning Decisions, Inc. 2004. A Proposed Approach for Wildlife Habitat and Corridor Protection.

Wenger, S. 1999. A Review of the Scientific Literature of Riparian Buffer Width, Extent, and Vegetation. Institute of Ecology, University of Georgia.

**Please Note:**

**This draft is a chapter of *Innovative Land Use Planning Techniques: A Handbook for Sustainable Development*, expected publication date June 2007, prepared as part of the Regional Environmental Planning Program by the NH Department of Environmental Services, the NH Association of Regional Planning Commissions, the NH Office of Energy and Planning, and the NH Local Government Center. All ordinances and regulations proposed for local adoption should be carefully reviewed by local officials and legal counsel. For more information or comments on the content of this chapter, contact Eric Williams at the N.H. Department of Environmental Services, [ewilliams@des.state.nh.us](mailto:ewilliams@des.state.nh.us) or (603) 271-2358.**

# Ossipee Watershed Coalition

## Natural Resources Planning Guide

### Chapter V-D - Biodiversity in the Ossipee Watershed

#### I. Biodiversity and Why is it Important?

**Biodiversity**, or biological diversity, is a complicated subject because it encapsulates life, or more specifically the myriad of living things that surround us from a mushroom in your backyard to a grizzly bear roaming the northern Rocky Mountains. Biodiversity is the fabric of life, a highly intricate patchwork of plants, animals, natural communities, and ecosystems woven together across the landscapes in which we live. Biodiversity can be broken down into several layers, which ultimately can help society make improved decisions about how to conserve biodiversity. Scientists commonly recognize four important levels of biological organization as fundamental components of biodiversity, including genes, species, ecosystems, and landscapes (Stein et. al. 2000).

The most intuitive measure of biodiversity for many people is species diversity (commonly defined as the total number of different species). In New Hampshire, more than 15,000 species are found in the state that have been identified and described by science (Taylor et. al. 1996). Nearly all of these have ranges extending well beyond New Hampshire, like the American robin (*Turdus migratorius*), which can be found throughout the country. However, New Hampshire also is home to a very limited number of species **endemic** to the state; i.e., these species are only found here in the Granite State. One example is the White Mountain Butterfly (*Oenis melissa semidea*), an alpine butterfly species that is endemic to New Hampshire, and only found within the Presidential Range of the White Mountains.



Chapter V-D  
Figure 1 White Mountain Butterfly  
Jeff Lougee © Photo

Genes, composed of DNA sequences, are the building blocks of life, and genetic diversity can be found within individual species. It is a vital facet of biodiversity conservation due to the important role of genetic diversity in paving the way for evolution, and enabling species to adapt to change. The genetics of a stand of eastern white pine (*Pinus strobus*) trees in New Hampshire will be different than a stand, for example in Virginia, and the genetics of individuals in the same stand can differ as well. This variation is of no small importance as certain traits that may make an individual white pine tree susceptible to disease, may not occur in another. For example, scientists have found that some white pine trees are quite resistant to white pine blister rust and white pine weevils, two of the principal pests and pathogens that impact white pine. The resistant individuals are critical for ensuring the long term viability of the species.

At the higher end of biological organization are ecosystems and landscapes. These capture critically important aspects of biodiversity beyond species and genetics, including such things as natural processes, pollination, predator-prey relationships, and regional weather and climate patterns. These are factors that dictate biodiversity at a higher scale, and are equally important to conserve and protect the full array of biodiversity. Our weather and climate in New Hampshire are very important aspects of where certain ecosystems are found in the White Mountains. For example, the distribution of alpine and subalpine ecosystems found on the highest summits is closely tied to climate. These ecosystems are typically found above 4,900 feet where climatic factors are too severe for the forests found lower down the slope. Changing regional weather patterns and climatic warming may alter these boundaries over time

pushing the alpine and subalpine ecosystems further up the mountain as the spruce fir forest from below find more favorable growing conditions higher on the mountain.

Conserving and maintaining the planet's biodiversity is important for many reasons, which span a broad array of human values and needs. Biodiversity plays a central role in maintaining and providing *ecosystem services* to human communities across the globe. The list of ecosystem services provided by intact and healthy ecosystems is long, and includes such critical things as the generation and maintenance of soils, cleaning and regulating our air and water, pollination of our plants and crops, helping to stabilize our climate, and providing food and medicine. While the economic value of these services has not been well accounted for in the past, much research is being done today to estimate the value of these services to society. In addition to these critical ecosystem services, some people believe biodiversity simply has an intrinsic value, while many cultures also place value in iconic nature symbols like the bald eagle.

For more information on the values of conserving biological diversity, please visit the website of the Natural Capital Project:

<http://www.naturalcapitalproject.org/>

## **II. Description of Local Biodiversity**

### **A. In New Hampshire**

New Hampshire is home to a broad array of biodiversity, which benefits from the relatively intact and forested conditions in the state. Although some sections of New Hampshire have been experiencing rapid growth and development over the past few decades, greater than 80% of the state still consists of intact forestland. In short, there are excellent opportunities to protect the state's biodiversity before growth and development causes irreplaceable losses of important biodiversity features.

Of the more than 15,000 species found in New Hampshire, there are roughly 2,000 plant species, and upwards of 12,000 animals. The vast majority of animals, approximately 11,000 species, are insects, many being poorly understood with little information available about their biology and life histories. Of the estimated 2,000 plant species to occur in the state, approximately 75% are native species, with the remainder being alien species that were introduced to the New Hampshire landscape from other parts of the world through settlement and global commerce (Taylor et. al. 1996).

*Natural communities* are the setting in which the numerous plant and animal species found in the state exist. They are recurring assemblages of plants and animals found in particular physical environments (Sperduto and Nichols 2004). There are many factors that influence the extent and location of natural communities, including elevation, aspect, slope, bedrock and surficial geology, soils, hydrology, and natural disturbances like fire and flooding. There are nearly 200 natural communities described in Natural Communities of New Hampshire (Sperduto and Nichols 2004) ranging from salt marshes in the Great Bay and seacoast area to lowland spruce fir forests in the far northern reaches of the state.

At the landscape scale, New Hampshire can be broken into several ecological sections and subsections based upon broad groupings of landform, geology, soils, and climate. These landscapes share in common broad forest types, similar flora and faunal composition, and recurring occurrences of natural communities. These areas have been extensively studied and described by scientist from the U.S. Forest Service, The Nature Conservancy, and other partner natural resource agencies and organizations. The Ossipee Watershed is largely located in the Sebago – Ossipee Hills and Plains subsection of the Lower

New England section of New Hampshire. A smaller portion extends into the White Mountains section of the state.

The New Hampshire Natural Heritage Bureau and The Nature Conservancy pay particular attention to documenting and tracking *exemplary natural communities* and rare species throughout the state. The occurrences of exemplary natural communities and rare species documented throughout the state are often referred to as *element occurrences* (“EOs”). Exemplary natural communities consist of high quality examples of common natural communities types, such as a hemlock beech oak pine forest, and most occurrences of uncommon or rare natural communities, like a pine barrens. Rarity is based on a scale of one to five, and when possible natural communities and rare species are given a ranking on this scale for both their global and state rarity. A description of the ranking system can be found in Appendix I of this section, while Appendix II in this section includes element occurrence records for the six principal watershed towns.

Only a small number of species have been *extirpated* from New Hampshire, and a similar small number of species that once occurred in New Hampshire or in adjacent ocean waters are now extinct. Seven animal species and 8 plants have been extirpated from New Hampshire, including mountain lion, woodland caribou, Eastern timber wolf, Loggerhead shrike, Henslow’s sparrow, golden eagle, and wolverine. Extirpated plant species include: alpine milk-vetch (*Astragalus alpinus* var. *brunetianus*), pretty sedge (*Carex woodii*), scarlet painted-cup (*Castilleja coccinea*), sea-chickweed (*Honckenya peploides* ssp. *robusta*), large twayblade (*Liparis liliifolia*), pelitory (*Parietaria pennsylvanica*), yellow-fringe orchid (*Platanthera ciliaris*), and rigid sedge (*Carex tetanica*). Labrador duck, sea mink, great auk, passenger pigeon, heath hen, and scrag whale are species that are now extinct (Taylor et. al. 1996, NH Natural Heritage Bureau 2007).



Chapter V-D Figure 2

## B. In the Ossipee Watershed

The majority of The Ossipee Watershed is found in the Sebago – Ossipee Hills and Plains subsection, which is characterized by transitional forest types with a number of species overlapping from forests typically found further north and south. This landscape is further distinguished by rugged topography and mid-elevation peaks and mountain ranges, which are interspersed with large areas of glacial outwash plains of sand and gravel, the state’s largest natural lakes, and some of New Hampshire’s largest wetlands. Within the Ossipee Watershed, The Ossipee Mountains, the Ossipee Pine Barrens, Ossipee Lake, and the wetlands found in Heath Pond Bog Natural Area are all examples of these distinguishing features.

The upper part of the Ossipee Watershed crosses the boundary into the White Mountain subsection where much of the land is part of the White Mountain National Forest. This portion of the watershed is dominated by the rugged mountains of the Sandwich Range, and includes such prominent peaks as Sandwich Mountain, Passaconaway, and the scenic Mt. Chocorua in Albany. This landscape is characterized by forests found throughout the White Mountains, including “northern hardwoods” dominated by sugar maple, American beech, and yellow birch at the middle elevations, and red spruce – balsam fir forests found at the higher elevations.

The Ossipee Watershed is home to a large number of uncommon plants, animals, and natural communities that are tied to the landscape features described above. The list includes 32 documented rare plant populations comprised of 15 species, 38 documented animal populations comprised of 22 species,



and 20 uncommon or exemplary natural communities found in 43 locations (see Appendix II in this section for a list of these rare species and exemplary natural communities by municipality). These important elements of biodiversity found in the Ossipee Watershed include such things as some of the largest populations in the state of the federally threatened small whorled pogonia (*Isotria medeoloides*), the state's last remaining pitch pine-scrub oak woodland natural community in the Ossipee Pine Barrens, and the state's largest concentration of whippoorwills and common nighthawks, also found in the Ossipee Pine Barrens.



**Chapter V-D, Figure 3:** Dan Hole Ponds and the Ossipee Mountains Matrix Forest Block  
Joe Klementovich © Photo

The Ossipee Watershed is also home to several large **matrix forest blocks** that have been identified by The Nature Conservancy through a process called **ecoregional planning**<sup>1</sup>. Matrix forest blocks are large areas of intact forest that are largely covered by natural land cover and have minimal fragmentation from roads or other forms of development. These forest blocks extend beyond the boundaries of the Ossipee Watershed, and also in one case across the state line into Maine.

Matrix forest blocks enable conservation biologists to add a coarse filter approach to conserving biodiversity. Conservation approaches that solely focus on **biodiversity hotspots**, areas with large concentrations of rare species and natural communities,

would fail to capture the myriad of other more common species and natural communities found on the landscape. While conservation of matrix forest blocks may indeed capture rare species and natural communities, keeping “common species common” is a fundamental aspect of matrix forest conservation.

## C. Highlighted Areas of Biodiversity Conservation Importance in the Ossipee Watershed

### 1. Dry Pine Woodlands

The Ossipee Watershed is home to approximately 4,550 acres of dry pine woodlands mapped as exemplary natural community occurrences by the New Hampshire Natural Heritage Bureau. This includes New Hampshire's last ecologically viable pitch pine - scrub oak woodland natural community, which is largely found in between Ossipee and Silver Lakes, and commonly known as the Ossipee Pine Barrens. The dry pine woodlands of the watershed also include an unusual mixed pine - red oak woodland natural community that has three of the four native pines found in the state (red, white, and pitch) growing together. Pine River State Forest in Ossipee and Effingham is home to a large occurrence of the mixed pine - red oak woodland community.

Along with the recreational and scenic values provided by these woodlands, they have exceptional value for the protection of groundwater resources, and wildlife habitat. The dry pine woodlands of the Ossipee Watershed are tightly aligned with the highest value recharge areas of the Ossipee aquifer. In many places, these woodlands overlay primary recharge

---

<sup>1</sup> Ecoregional planning provides the “blueprint” for conservation action followed by The Nature Conservancy. Ecoregional conservation plans have been completed for the three ecoregions that are found in New Hampshire (Northern Appalachian, Lower New England, and the North Atlantic Coast). These plans identify and describe the biodiversity that make up these ecoregions, set large-scale conservation goals, and pinpoint a “portfolio” of sites and places for conservation action. The portfolio consists of the best known sites for protecting matrix forests, exemplary natural communities, and globally rare species within the respective ecoregions.

<b>Chapter V-D, Table 1: Acres of Protected Dry Pine Woodlands in the Ossipee Watershed</b>		
<b>Conservation Area</b>	<b>Natural Community Type</b>	<b>Acres</b>
Pine River State Forest	Mixed pine – red oak woodland	1,407
Heath Pond Bog Natural Area	Mixed pine – red oak woodland	56
	<b>Total Acres Protected</b>	<b>1,463</b>
White Lake State Park	Pitch pine scrub oak woodland <sup>2</sup>	153
The Nature Conservancy – West Branch Pine Barrens Preserve	Pitch pine scrub oak woodland	1,148
Goodwin and Burke Town Forests (Madison)	Pitch pine scrub oak woodland	61
Freedom Town Forest	Pitch pine scrub oak woodland	200
Pine River State Forest	Pitch pine scrub oak woodland	256
	<b>Total Acres Protected</b>	<b>1,818</b>

areas with transmissivity values ranging from 6,000 – 8,000 square feet per day (Moore and Medalie 1995). Undeveloped and protected areas of woodland and forest above primary recharge zones of the aquifer reduce the chance of contamination from faulty septic systems, or chemical contaminants associated with commercial development.

The dry pine woodlands of the watershed are also a highly important wildlife habitat, and have been identified in the New Hampshire’s recently completed Wildlife Action Plan as a “habitat at risk”. The occurrences of dry pine woodlands in the watershed have also been identified in the Wildlife Action Plan as areas of “highest quality habitat in New Hampshire,” and therefore sites of statewide conservation importance (NH Fish and Game 2005). In the watershed, these woodlands provide habitat for an amazing number of uncommon bird and insect species. The Ossipee Pine Barrens includes the states largest concentration of whippoorwills, a species that has declined dramatically across its range over the past 20 years (Hunt 2004, NY State Breeding Bird Atlas 1980 - 1985 and 2000 - 2005). The Ossipee Pine Barrens are also home to 17 state listed moth and butterfly species, several of which are not found elsewhere in New Hampshire. Two of these species are considered globally rare because they are only found in pine barrens habitats (Natureserve 2007).

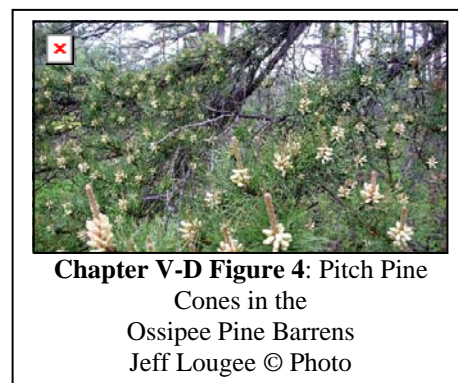

## 2. Matrix Forest Blocks

The Nature Conservancy has identified four matrix forest blocks that at-least partially fall within the Ossipee Watershed, including the Pine River (68,540 acres), Ossipee Mountains (58,851 acres), Silver Lake (22,675 acres), and Sandwich (102,163 acres) blocks. Matrix forest blocks are unfragmented forest areas on the landscape that have been identified using GIS (Geographic Information Systems). These forest blocks have the following characteristics:

- a. are largely dominated by natural landcover,
- b. are relatively unfragmented by roads and/or other forms of development, and
- c. are large enough in size to accommodate viable populations of some large mammals, forest interior birds, and other species requiring large forested areas.

Please see Appendix III in this section for more information on the process of identifying matrix forest blocks and selecting priority blocks for conservation action.

<sup>2</sup> Pitch pine – scrub oak woodland are commonly referred to as “pine barrens” ecosystems

Chapter V-D, Table 2: Protection Status of Matrix Forest Blocks in the Ossipee Watershed		
Matrix Forest Block	Acres of Conservation Land	Acres of Core Area Protection
Sandwich	92,801	423
Pine River	16,712	903
Ossipee Mountains	20,118	7,199
Silver Lake	5,961	2,159

Amongst the four blocks, there are currently 135,592 acres of conservation land, a large majority of which is found in the White Mountain National Forest in the Sandwich Matrix Forest Block. The table above shows the protected land by each matrix forest block, and the acreage within each block that can be counted towards permanent “core area” protection (see below for more info. on core area protection).

A key factor in developing and conserving matrix forest blocks is meeting minimum size thresholds for these areas to absorb natural disturbances and provide areas large enough to sustain viable populations of wide ranging animals and forest interior species. Figure 5 shows the scaling factors used to determine the minimum size requirements for *core areas* in the matrix forest blocks found in the Ossipee Watershed. Core areas are forests reserves where the primary goal is to manage for mature, old forests that benefit many species not found in intensively managed forests where the primary goal is for timber production. As illustrated in the figure above, a minimum core area of 15,000 acres would be able to absorb the largest historic natural disturbances, and sustain viable populations of many forest interior species. Providing an area that is 4x the largest historic disturbance size guarantees a refuge within the reserve for those species that would not persist in the area impacted by the disturbance. For many forest interior birds, a minimum number of breeding pairs required to constitute a viable population is 25. Broad winged hawk, which has an average territory size per pair of 569 acres, would therefore require a 14,225 acre area to sustain a viable population.

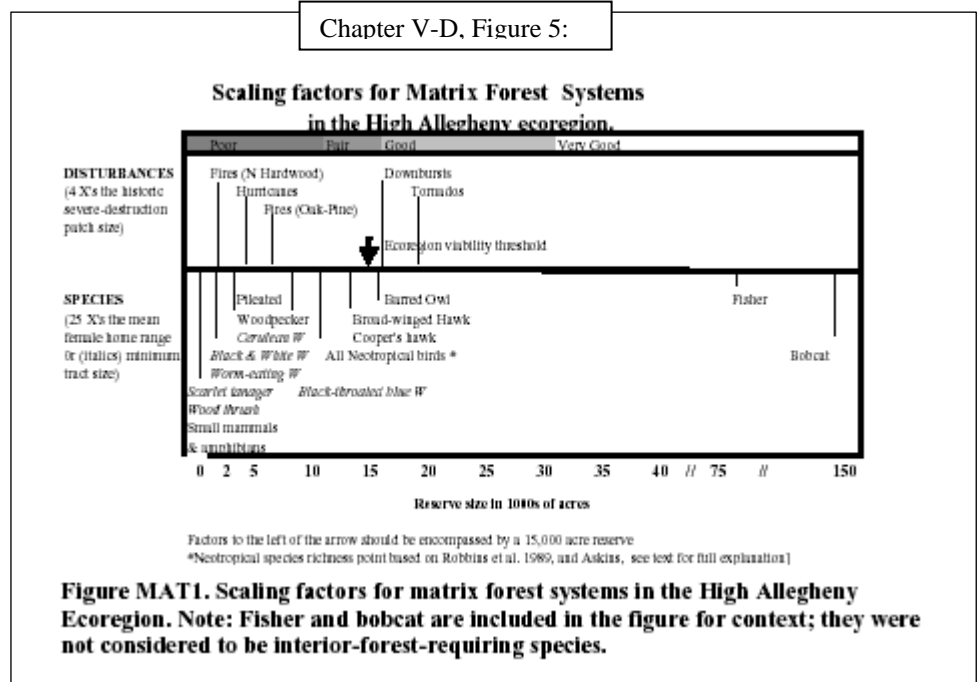

### 3. Exemplary Wetland Complexes

Wetlands are an important and key feature of the Ossipee Watershed, which includes some of the state’s largest, most diverse, and best condition wetland complexes. There are approximately 2,300 acres of exemplary wetlands that have been documented and mapped within the Ossipee Watershed at 19 different sites. These include several important wetland natural communities and ecosystem types. **Wetland ecosystems** include large complexes that are made up of several natural community types. The exemplary wetland ecosystems and natural communities mapped in the Ossipee Watershed include: kettle hole bog ecosystem, medium level fen ecosystem, poor level/fen bog system, sandplain basin marsh

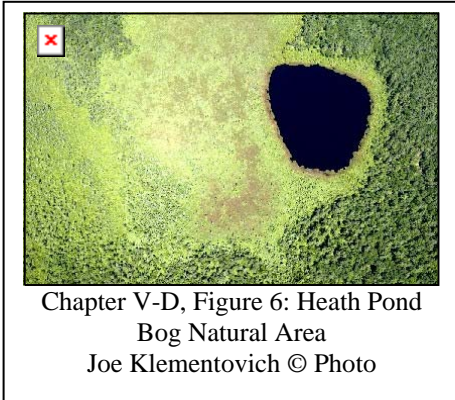

system, winterberry cinnamon fern wooded fen, black spruce – larch swamp, and red maple floodplain forest. Table 3 below shows the acreage and current protection status of these exemplary wetlands.

In addition to being high quality, exemplary occurrences, these wetland ecosystems and natural communities have many other values, such as providing wildlife habitat, and helping to regulate water, which is explained in greater detail in Chapter V.B. Some of the exemplary wetland ecosystems found in the watershed are also known to contain rare species populations, including spotted and Blanding’s turtles, potential nesting habitat for bald eagles, as well as a number of uncommon plant species. Populations of arethusa (*Arethusa bulbosa*), swamp birch (*Betula pumila*), and slender cotton sedge (*Eriophorum angustifolium*) have all been documented in wetlands in the Ossipee Watershed.

<b>Chapter IV, Table 3: Acres of Protected Exemplary Wetlands in the Ossipee Watershed</b>			
<b>Conservation Area</b>	<b>Owner</b>	<b>Wetland Type</b>	<b>Acres</b>
Bearcamp Memorial Forest	New England Forestry Foundation	Kettle hole bog system	32
		Medium level fen system	28
		Red maple floodplain forest	205
Heath Pond Bog Natural Area	State of New Hampshire	Kettle hole bog system	50
		Poor level fen/bog system	576
Ossipee Lake Natural Area	State of New Hampshire	Medium level fen system	58
		Poor level fen/bog system	245
Pine River State Forest	State of New Hampshire	Black spruce - larch swamp	72
		Black spruce - larch swamp	16
		Kettle hole bog system	17
		Sand plain basin marsh system	1.15
		Temperate minor river floodplain system	96
		Winterberry - cinnamon fern wooded fen	1.21
	Town of Ossipee	Kettle hole bog system	15
	Town of Tamworth	Kettle hole bog system	5
West Branch Pine Barrens Preserve	The Nature Conservancy	Medium level fen system	3
		Red maple floodplain forest	147
White Mountain National Forest	USDA Forest Service	Sand plain basin marsh system	5
Wilkinson Brook Basin Conservation Area	Various	Medium level fen system	398
		<b>Total Protected Acres</b>	<b>1,971</b>

#### 4. Pond Shore Communities

Intact pond shore communities are exceedingly uncommon in New Hampshire and throughout their range due to several factors, most importantly: 1. the extensive second home development that has occurred around many of our lakes and ponds where these communities are found, 2. the intensive recreational use of beach areas that harbor pond shore communities, which are easily damaged via foot

traffic from beach goers, and 3. the control of water levels that changes the normal flooding and ice-souring regimes that maintain these communities. In addition to their rarity, pond shore communities tend to harbor rare and uncommon plant species, such as golden heather (*Hudsonia ericoides*), beach heather (*Hudsonia tomentosa*), and grassleaf goldenrod (*Euthamia caroliniana*). These hardy plants are capable of handling the rigorous conditions and environmental factors present in these pond shore settings, but are not found in many other locations on the landscape.

**Chapter V-D, Table 4: Acres of Protected Exemplary Pond Shore Communities in the Ossipee Watershed**

<b>Conservation Area</b>	<b>Owner</b>	<b>Pond Shore Type</b>	<b>Acres</b>
Ossipee Lake Natural Area – <i>Long Sands Beach</i>	State of New Hampshire	Hudsonia inland beach strand	4.96
		Sandy pond shore system	4.96
Ossipee Lake Natural Area – <i>Pine River Beach</i>	State of New Hampshire	Hudsonia inland beach strand	1.49
		Sandy pond shore system	1.49
The Nature Conservancy	The Nature Conservancy	Hudsonia inland beach strand	2.33
		Sandy pond shore system	3.34
<b>Total Protected Acres</b>			<b>19</b>

There are only 13 documented occurrences of sandy pond shore ecosystems in the state, and just four examples of the globally rare hudsonia inland beach strand community. Of the 13 sandy pond shore ecosystems documented in New Hampshire, four are in the Ossipee Watershed and these include within them all four examples of the hudsonia inland beach strand communities found in the state. As shown in Table 4 above, these ecosystems are exceedingly small, making up just 19 acres of the Ossipee Watershed

### **III. Current and Potential Threats to Highlighted Areas of Biodiversity Conservation Importance in the Ossipee Watershed**

#### **A. Dry Pine Woodlands (“Pine Barrens”)**

These woodlands are highly threatened by development, gravel mining, and fire suppression. Because they are typically found on level, sandy outwash soils, or sand and gravel eskers, commercial and residential development, and gravel extraction are common types of land use conversions. Much of the development along Route 41 in Tamworth, Ossipee, and Madison is located in areas that were historically part of the Ossipee Pine Barrens. Sand and gravel is one of New Hampshire’s leading exports, and the numerous gravel pits found throughout the watershed tap into the sand and gravel resources that typically underlay the dry pine forests. (<http://minerals.usgs.gov/minerals/pubs/state/2004/nhstmyb04.pdf>).

Because of the preponderance of droughty sandy soils in New Hampshire, the state once had tens of thousands of acres of pine barrens and dry pine woodlands. Much of the lower Merrimack River Valley once supported extensive pine barrens, which have been largely replaced by the cities of Nashua, Manchester, and Concord. The Nature Conservancy has estimated the historic extent of the Ossipee Pine Barrens at approximately 8,665 acres. Today, about 2,462 acres of this ecosystem remain.

Even after they are protected from development or gravel mining, the dry pine woodlands of the watershed are threatened by fire suppression, and fragmentation created by development. Because these woodlands are found on droughty soils, they have been subject to frequent fires caused by lightning strikes, and the vegetation is specially adapted to survive this disturbance. For example, pitch pines are one of the only pines able to sprout from their roots, much like an oak tree, which enable a tree to survive fire if the above ground portion is killed. The common ground cover in these woodlands of low sweet blueberry also benefits from fire as this species produces significantly more flowers, and thus blueberries, once the old branches are consumed in a fire. These plants also vigorously sprout from their roots after the above ground portion has been killed.

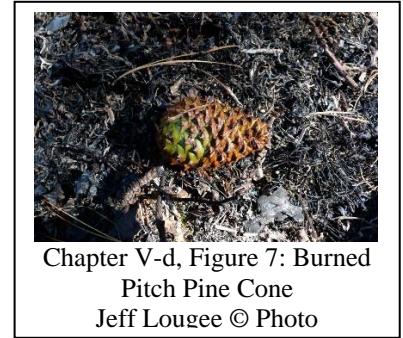

In the absence of fire, fuels (any vegetation, woody debris, or leaf litter that is available to burn) accumulate in these woodlands to the point where fires can be difficult to control, and thus devastating to surrounding human settlements. These types of fire can also be ecologically damaging since the historic fires before human settlement were likely to burn in a patchy nature, slowly consuming the fuels during repeated fires that would sweep across the landscape. The absence of fire also enables the establishment of species not adapted to fire, which can displace the specialized pine barrens vegetation, and the uncommon wildlife inhabiting these unique woodlands.

Residential and commercial development that is in close proximity to these woodlands poses a number of challenges to natural resource managers. Foremost, conducting prescribed burns to reduce the amount of fuel that has accumulated and remove the encroachment of fire intolerant species is made more complicated, while a number of additional factors pose threats to the uncommon wildlife found in these woodlands. Many of the uncommon bird species are ground and shrub nesting birds, which can be subject to very high levels of nest depredation from domestic cats associated with the surrounding residential areas. Night flying insects are also lost to “bug zappers.”

## B. Matrix Forest Blocks

Because of the pace of development in New Hampshire, the integrity and ecological values of a number of matrix forest blocks in the state is declining. New Hampshire is the fastest growing state in New England, losing approximately 17,500 acres of forestland each year (Sundquist and Stevens 1999). While the Ossipee Watershed may not be experiencing the growth rates found in southern parts of the state, the watershed towns are forecast to have growth rates ranging from 40-80% by 2020, with the towns of Madison and Freedom having projected growth rates of 60-80% (NH Office of State Planning 1997).

Development within matrix forest blocks will erode the ecological values of these areas over time to support viable populations of some large mammals and forest interior species that are not found in more fragmented landscapes. Commercial and residential development results in two primary challenges to biodiversity conservation, including the conversion to anthropogenic landcover types and the concomitant increase in road densities to facilitate development. The loss of natural landcover and increased road densities present many challenges for the intrinsic wildlife habitat values of these areas, most importantly the direct loss of habitat through land conversion and the *fragmentation effects* associated with both the habitat conversion and increased road densities.

Habitat fragmentation from roads and development presents many challenges for wildlife and other organisms, with seven key issues commonly recognized by conservation biologists: mortality from

road construction, mortality from collision with vehicles, modification of animal behavior, disruption of the physical environment, alteration of the chemical environment, the spread of exotic and invasive species, and changes of human use of land and water (Trombulak and Frissell 2000). Within the Ossipee Watershed, road kills of wildlife, roads bisecting wetlands (Route 25, Huntress Bridge Road) and other key wildlife habitats, and populations of invasive species along roadsides (Japanese knotweed) are all examples of these issues at work. Matrix forest block and protection of core areas within these blocks can help to mitigate these challenges associated with development and roads.

### C. Exemplary Wetland Complexes

Development and roads can also have significant negative impacts on exemplary wetland complexes in the watershed for many of the same reasons cited above. Many wildlife species use wetlands for some aspect of their life history, from breeding to forage and feeding, and the bisection of these habitats by roads, or their fragmentation from adjacent, upland terrestrial habitats can cause considerable stress on wildlife populations by altering their normal behavior, and/or use of dispersal and travel corridors.

The intense stress this places on turtle populations exemplifies this threat, as turtles can sometimes disperse significant distances from wetlands they might use for over-wintering. Blanding's turtles in Maine were found to sometimes use as many as six different wetlands during the summer months and travel up to 1.2 miles between wetlands (Joyal 1996). Because turtles are long-lived, have few predators, and are slow to reproduce, road mortalities can be a significant obstacle to their long-term viability at a given site. Relatively few losses of individuals from road mortalities can result in a marked decrease in the population's size of some turtle species. This is especially true for some of the rare species, such as spotted and Blanding's turtles, which are both known to occur within wetland complexes in the watershed.



Chapter V-D, Figure 8: Huntress Bridge Road and Watt's Wildlife Sanctuary  
Joe Klementovich © Photo

Many of our wetlands are also susceptible to being invaded by exotic and invasive species, which can largely displace native species within a wetland complex and significantly decrease the plant diversity. While the exemplary wetland complexes in the watershed are relatively free of exotic and invasive species, small numbers and populations of two highly aggressive invasive plants have been documented in some locations, including purple loosestrife (*Lythrum salicaria*) and phragmites (*Phragmites australis*). These plants can become established in many different ways, but are typically associated with development and road construction, which create vectors for dispersal and facilitate seed dispersal. Maintaining adequate wetland buffers can be one way to prevent the spread and

establishment of these plants into the exemplary wetland complexes in the watershed.

### D. Pond Shore Communities

As noted above, the key threats to our pond shore communities come from lake and pond shore development, and intense recreational pressure that are placed upon the "beach" areas harboring these communities. Many of the uncommon plant species found in the pond shore communities are considered very hardy and tolerant of the difficult environmental conditions present in these settings (wind, wave action, ice scouring), but are not tolerant to repeated and heavy foot traffic. In particular, "turf"

communities present in some of our sandy pond shore communities are particularly sensitive as the turf patches take very long periods of time to develop, and are easily disrupted as foot traffic kills the plants whose root systems are holding the substrates intact (for more information on sandy pond shore systems please see Natural Communities of New Hampshire, Sperduto and Nichols 2004).

Manipulation of lake levels that change the normal flooding and ice-scouring of the beach areas harboring these communities can also cause significant stress. Without significant flooding and ice-scouring, in some cases woody shrubs can invade these communities and displace the more uncommon plant communities and species found in the more disturbed areas of the ecosystem. Furthermore, lowering water levels for too long a duration can displace and eliminate the shallow emergent aquatic plant communities that interface with the pond shores.

#### **IV. Recommendations for Conservation Action to protect Biodiversity in the Ossipee Watershed**

Protecting biological diversity in the Ossipee Watershed will require conservation action on many levels. To support conservation actions being taken in the watershed, municipalities may consider the following:

##### **A. Understanding the Biological Diversity of Your Town**

- Consider writing grants to fund comprehensive natural resource inventories to better understand and inform conservation actions in town. Comprehensive natural resource inventories can help towns develop a much stronger understanding of unique areas within the community. While the New Hampshire Natural Heritage Bureau maintains an extensive database on exemplary natural communities and rare species populations throughout the state, the data is not comprehensive, and there is a very strong probability that additional areas of ecological importance are located in any given town.
- Conservation commissions should support natural resource inventories and mapping being conducted by private non-profit conservation groups and government agencies. Local contacts to obtain landowner permission and build town support for these types of initiatives can be invaluable, and result in highly valuable products to the town at a limited cost.

##### **B. Helping to Protect the Biological Diversity of Your Town**

- Support private non-profit conservation groups working to protect land in the watershed. This can come in many forms, from financial support to political support. Many non-profit conservation groups have developed extensive expertise in leveraging public dollars for conservation through program such as Forest Legacy, the Landowner Incentive Program (LIP), the NH Conservation License Plate Program, and others. Often, successful applications and proposal to these programs can hinge on strong community support, and the support of town officials.
- Consider developing municipally-based financial resources and funding mechanisms for conservation to protect ecologically important lands through direct acquisition, or in support of protection projects being lead by private non-profit conservation groups or other entities. Some potential funding mechanisms to support land conservation include:
  1. Dedicating all, or a portion of land use change tax funds to a land conservation fund,
  2. Consider bonding for critical conservation projects. Both of these funding strategies have been very successful in several communities across the state.



3. Consider enacting protective zoning and ordinances to advance land conservation and the protection of biological diversity. Important considerations are enacting protective measures to:
  - a) Support the protection of matrix forest blocks by helping to maintain their unfragmented character and limited road perforation. This could include considering zoning to advance a cluster development approach while strongly limiting development in currently unfragmented blocks of land in town, especially where these areas are included in matrix forest blocks.
  - b) Support the protection of the rare dry pine forests that overlay critical recharge areas of the Ossipee aquifer by strongly limiting development in these areas. Current groundwater protection ordinances are not adequate to protect the uncommon forests found in these areas, or the clean recharge areas needed to ensure the future protection of the water quality in the aquifer.
  - c) Limit the upgrading of Class VI or seasonal roads when these roads are found in unfragmented forest areas in town, especially when these areas fall within matrix forest blocks or other unique natural areas. Consider removing Class VI roads from the town register when these roads intersect highly threatened natural communities or rare species populations.
4. Consider working with private non-profit conservation groups and government agencies with expertise in biodiversity conservation to strategically protect town-owned lands (tax deeds, conservation commission managed lands, town forests, parcels owned for municipal facilities, etc.). This would entail ensuring these lands have permanent protection that supports the protection of their unique ecological values.
5. Consider designating prime wetlands to support the protection of the highly unique and important wetland complexes found in the Ossipee Watershed. Well designed wetland mapping projects will need to be implemented to facilitate this process.
9. Support the protection of ecologically important areas through conservation easements by
  - a) developing capacity to hold and steward conservation easements,
  - b) providing education to landowners on the value and tax incentives of conservation easements, and
  - c) collaborating with non-profit conservation groups and government agencies working to protect important areas with conservation easements.
10. Financially supporting the acquisition of conservation easements can be a cost effective way to conserve ecologically valuable lands in the community at low cost, while maintaining a traditional ownership pattern.

### **C. Providing Sound Stewardship for the Biodiversity of your Town**

- Some unique areas, such as pine-barrens, require special management in the form of prescribed burning in order to maintain them over time. Town's should work with non-profit conservation groups and/or government agencies with expertise in maintaining these ecosystems to manage unique pine-barrens areas found on town lands.
- A critical aspect of maintaining exemplary wetlands and aquatic biodiversity is ensuring proper water flow and passage. Towns should work with non-profit conservation groups and other agencies evaluating culvert capacity in the watershed for providing adequate water flow and providing for fish and other wildlife passage. Based on the results, towns should consider working to incrementally replace culverts not adequate to maintain proper water flow and aquatic connectivity.

- Towns should consider supporting education efforts to support BMPs for land management that include provisions for protect unique areas important for biodiversity conservation.

## V. Resources and Links

<http://www.naturalcapitalproject.org/>

<http://www.nature.org>

<http://www.spnhf.org>

<http://www.dred.state.nh.us/divisions/forestandlands/bureaus/naturalheritage/biodiversity.htm>

<http://extension.unh.edu/forestry/FORNHLL.htm>

<http://www.nescb.org/links/NH.html>

[http://www.sustainableunh.unh.edu/biodiv\\_ed/background.html](http://www.sustainableunh.unh.edu/biodiv_ed/background.html)

<http://www.lchip.org/>

## VI. References

Barbour, H., M. Anderson, S. Khana, A. Olivero, B. Zaremba. 2000. Lower New England - Northern Piedmont Ecoregion Conservation Plan: 1st Iteration. The Nature Conservancy, Boston MA.

Hunt, P. 2004. Summary of 2004 Whip-poor-will Surveys in New Hampshire. New Hampshire Audubon, Concord, NH.

Joyal, L.A., M. McCollough, M.L. Hunter Jr. 2001. Landscape Ecology Approaches to Wetland Species Conservation: a Case Study of Two Turtle Species in Southern Maine. Conservation Biology: 15: 1755-1762.

Lindenmayer, D.B. and J.F. Franklin. 2002. Conserving Forest Biodiversity, A Comprehensive Multiscaled Approach. Island Press, Washington D.C.

Lougee, J.P. 2005. Vegetation, Landcover, and Fuel Mapping of the Ossipee Pine Barrens, Carroll County, New Hampshire. The Nature Conservancy, Concord, NH.

Lougee, J.P. 2007. Draft Conservation Area Plan for the Pine River Matrix Forest Block. The Nature Conservancy, Concord, NH.

Lougee, J.P. and D.D. Sperduto. 2007. Effingham Wetlands Mapping: A survey of the South River North and Marstin Brook East Wetland Complexes. The Nature Conservancy, Concord, NH.

Moore, R.B., and Medalie, Laura, 1995, Geohydrology and water quality of stratified-drift aquifers in the Saco and Ossipee River Basins, east-central New Hampshire: U.S. Geological Survey Water-Resources Investigations Report 94-4182, 240 p.

NatureServe: An online encyclopedia of life (web application). 2001. Version 1.3. Arlington, Virginia, USA: Association for Biodiversity Information. Available: <http://www.natureserve.org>

Newton, R.M. 1974. Surficial geology of the Ossipee Lake Quadrangle, New Hampshire. New Hampshire Department of Resources and Economic Development. Concord, NH.

New York State Breeding Bird Atlas 2000 [Internet]. 2000 - 2005. Release 1.0. Albany (New York): New York State Department of Environmental Conservation. [updated 2007 Jun 11; cited 2007 Oct 18]. Available from: <http://www.dec.ny.gov/animals/7312.html>.

New York State Breeding Bird Atlas [Internet]. 1980 - 1985. Release 1.0. Albany (New York): New York State Department of Environmental Conservation. [updated 2007 Jun 6; cited 2007 Oct 18]. Available from: <http://www.dec.ny.gov/animals/7312.html>.

Poiani, K.A., Richter, B.D., Anderson, M.G., and Richter, H.E. Biodiversity Conservation at Multiple Scales: Functional Sites, Landscapes, and Networks. *Bioscience*: 50: 133-156.

Sperduto, D.D, and W.F. Nichols. 2004. Natural Communities of New Hampshire. NH Natural Heritage Bureau, Department of Resources & Economic Development, Concord. 229 pp.

Sperduto, D.D. 2000. A Classification of Wetland Natural Communities in New Hampshire. NH Natural Heritage Bureau, Department of Resources & Economic Development, Concord. 156 pp.

Sperduto, D.D., W.F. Nichols and N. Cleavitt. 2000. Bogs and Fens of New Hampshire. NH Natural Heritage Bureau, Department of Resources & Economic Development, Concord. 50 pp. plus appendices

Sperduto, D.D. and W.F. Nichols. 2000. Exemplary Bogs and Fens of New Hampshire. NH Natural Heritage Bureau, Department of Resources & Economic Development, Concord. 27 pp. plus appendices.

Sperduto, K. Crowley, and B. Kimball. Forest History and Significant Natural Features of the Pine River State Forest. NH Natural Heritage Bureau, Department of Resources & Economic Development, Concord. 33 pp. plus appendices

Sundquist, D. and M. Stevens. 1999. New Hampshire's Changing Landscape: Population Growth, Land Use Conversion, and Resource Fragmentation in the Granite State. The Society for the Protection of New Hampshire Forests and The Nature Conservancy, Concord, NH.

Taylor, J., T.D. Lee, and L.F. McCarthy. 1996. New Hampshire's Living Legacy: The Biodiversity of the Granite State. New Hampshire Fish and Game, Nongame and Endangered Wildlife Program, Concord, NH. 97 pp.

Trombulak, S.C. and C.A. Frissell. 2000. A Review of the Ecological Effects of Roads on Terrestrial and Aquatic Communities. *Conservation Biology*: 14: 18-30.

Stein, B.A., L.S. Kutner, and J.S. Adams. 2000. Precious Heritage: The Status of Biodiversity in the United States. Oxford University Press. New York, NY.

## Appendix I to Biodiversity: Explanation of State and Global Ranks

Ranks describe rarity both throughout a species' range (globally, or "G" rank) and within New Hampshire (statewide, or "S" rank). The rarity of sub-species and varieties is indicated with a taxon ("T") rank. For example, a G5T1 rank shows that the species is globally secure (G5) but the sub-species is critically imperiled (T1).

<i>Code</i>	<i>Examples</i>	<i>Description</i>
<b>1</b>	G1 S1	Critically imperiled because extreme rarity (generally one to five occurrences) or some factor of its biology makes it particularly vulnerable to extinction.
<b>2</b>	G2 S2	Imperiled because rarity (generally six to 20 occurrences) or other factors demonstrably make it very vulnerable to extinction.
<b>3</b>	G3 S3	Either very rare and local throughout its range (generally 21 to 100 occurrences), or found locally (even abundantly at some of its locations) in a restricted range, or vulnerable to extinction because of other factors.
<b>4</b>	G4 S4	Widespread and apparently secure, although the species may be quite rare in parts of its range, especially at the periphery.
<b>5</b>	G5 S5	Demonstrably widespread and secure, although the species may be quite rare in parts of its range, particularly at the periphery.
<b>U</b>	GU SU	Status uncertain, but possibly in peril. More information needed.
<b>H</b>	GH SH	Known only from historical records, but may be rediscovered. A G5 SH species is widespread throughout its range (G5), but considered historical in New Hampshire (SH).
<b>X</b>	GX SX	Believed to be extinct. May be rediscovered, but evidence indicates that this is less likely than for historical species. A G5 SX species is widespread throughout its range (G5), but extirpated from New Hampshire (SX).

Modifiers are used as follows.

<i>Code</i>	<i>Examples</i>	<i>Description</i>
<b>Q</b>	G5Q GHQ	Questions or problems may exist with the species' or sub-species' taxonomy, so more information is needed.
<b>?</b>	G3? S3?	The rank is uncertain due to insufficient information at the state or global level, so more inventories are needed. When no rank has been proposed the global rank may be "G?" or "G5T?"

When ranks are somewhat uncertain or the species' status appears to fall between two ranks, the ranks may be combined. For example:

G4G5	The species may be globally secure (G5), but appears to be at some risk (G4).
G5T2T3	The species is globally secure (G5), but the sub-species is somewhat imperiled (T2T3).
G4?Q	The species appears to be relatively secure (G4), but more information is needed to confirm this (?). Further, there are questions or problems with the species' taxonomy (Q).
G3G4Q S1S2	The species is globally uncommon (G3G4), and there are questions about its taxonomy (Q). In New Hampshire, the species is very imperiled (S1S2).

## Appendix II to Biodiversity: Element Occurrence Records for Six Ossipee Watershed Towns

The tables below provide the Element Occurrence (“EOs”) records for the six principal towns of the Ossipee Watershed; Effingham, Freedom, Madison, Ossipee, Tamworth, and Sandwich. This data is maintained by the New Hampshire Natural Heritage Bureau, DRED Department of Forest and Land, in their Biotics database. The database includes all of the documented rare species (plants and animals) populations and exemplary natural communities that have been found to date throughout the state (e.g. “Element Occurrences (EOs)”). The tables include all of the records for the six towns, thus multiple listings of a single species means that the number of listings corresponds to the number of distinct populations identified and mapped within the town. The data that has been included in these tables is as follows:

*Scientific Name* – The scientific name of the species or natural community

*Common Name* – The common name of the species or natural community

*EO Rank* – A measure of the viability of the occurrence, based on the analysis of three factors: **size** of the population or natural community, **condition** of the population or natural community, and the condition of the surrounding area (e.g. **landscape context**). For many of the EOs in Biotics, the rank is based on detailed ranking specifications for the species or natural community. Ranking specifications provide guidance on ranking the occurrence based upon the known biology/ecology of the EO, and the data available on the EO from known occurrences throughout the state. Ranks are assigned from A – D, with A being the highest (best) rank.

*Federal Protection Status* – The protection status of the species under the federal Endangered Species Act

*State Protection Status* – The protection status of the species under the state’s Native Plant Protection Act of 1987

*G Rank* – The global rarity rank of the species or natural community

*S Rank* – The state rarity rank of the species or natural community

*First Observation* – The date of the first observation of the species or natural community

*Last Observation* – The date of the last observation of the species or natural community

### Effingham Element Occurrence Records

Scientific Name	Common Name	EO Rank	Federal Protection Status	State Protection Status	G Rank	S Rank	First Observation	Last Observation
<i>Isotria medeoloides</i>	Small Whorled Pogonia	C-	T	T	G2	S2	1999-09-24	1999-09-24
Medium level fen system		A-	--	--	GNR	S3	1998-08-14	1998-08-14
Mixed pine - red oak woodland		AB	--	--	G3G4	S1	1989-09-21	1989-09-21
Mixed pine - red oak woodland		B	--	--	G3G4	S1	1999-07-20	1999-10-01
Poor level fen/bog system		A	--	--	GNR	S3	1998-07-16	1998-08-04
<i>Progne subis</i>	Purple Martin		--	E	G5	S1B	1969	2004-06-24
Sand plain basin marsh system		B-	--	--	GNR	S2	1999-09-24	1999-10-01

### Freedom Element Occurrence Records

Scientific Name	Common Name	EO Rank	Federal Protection Status	State Protection Status	G Rank	S Rank	First Observation	Last Observation
<i>Asclepias amplexicaulis</i>	Blunt-leaved Milkweed		--	T	G5	S2	1966	1966
<i>Asclepias amplexicaulis</i>	Blunt-leaved Milkweed	A	--	T	G5	S2	1972	1988
<i>Euthamia caroliniana</i>	Grassleaf Goldenrod		--	E	G5	S1	1972-07-19	1972-07-19
<i>Gavia immer</i>	Common Loon		--	T	G5	S3B	2000-05-17	2005-07-18
<i>Hudsonia ericoides</i>	Golden Heather	C	--	T	G4	S2	1990	1990-04-30
<i>Hudsonia ericoides</i>	Golden Heather	D	--	T	G4	S2	1988	1988
<i>Hudsonia ericoides</i>	Golden Heather	H	--	T	G4	S2	1932	1932-08-08
<i>Hudsonia inland beach strand</i>		A	--	--	GNR	S1	1972	1986-06-16
<i>Hudsonia inland beach strand</i>		B	--	--	GNR	S1	1966	1990-04-30
<i>Hudsonia tomentosa</i> var. <i>intermedia</i>	Hairy Hudsonia	B-	--	T	G5T4	S2	1964	2000-06-21
<i>Hudsonia tomentosa</i> var. <i>intermedia</i>	Hairy Hudsonia	NR	--	T	G5T4	S2	1966	2001-08-01
<i>Isoetes lacustris</i>	Large-spored Quillwort	H	--	E	G5	SH	1940	1940-08-28
<i>Lupinus perennis</i>	Wild Lupine	A	--	T	G5	S2	1936	1986-06-16
Medium level fen system		B-	--	--	GNR	S3	1966	1990-04-30
<i>Myriophyllum farwellii</i>	Farwell's Water Milfoil		--	E	G5	SH	1969	1969-08-08
<i>Myriophyllum farwellii</i>	Farwell's Water Milfoil	H	--	E	G5	SH	1935	1935-08-28
<i>Notropis bifrenatus</i>	Bridled Shiner		--	--	G3	S3	1992-07-22	2005-09-19
<i>Panicum rigidulum</i> ssp. <i>Pubescens</i>	Long-leaved Panic Grass		--	E	G5T5?	SH	1934-08-10	1966-09-11
Pitch pine - scrub oak woodland		A-	--	--	GNR	S1S2	1983	2006-04-12
<i>Progne subis</i>	Purple Martin		--	E	G5	S1B	2002-06-17	2003-07-22

**Freedom Element Occurrence Records Continued**

Scientific Name	Common Name	EO Rank	Federal Protection Status	State Protection Status	G Rank	S Rank	First Observation	Last Observation
<i>Proserpinaca pectinata</i>	Mermaidweed		--	E	G5	SH	1975	1975-09-13
<i>Proserpinaca pectinata</i>	Mermaidweed	NR	--	E	G5	SH	1969	1969-08-26
Red maple floodplain forest		AB	--	--	GNR	S2S3	1998-09-04	1998-09-04
<i>Rhynchospora capillacea</i>	Needle Beak Sedge		--	E	G4	S1	1958	1958-07-10
Sandy pond shore system		B	--	--	GNR	S2	1971	1990-04-30
Sandy pond shore system		B	--	--	GNR	S2	1993-10-26	1993-10-26

**Madison Element Occurrence Records**

Scientific Name	Common Name	EO Rank	Federal Protection Status	State Protection Status	G Rank	S Rank	First Observation	Last Observation
<i>Accipiter cooperii</i>	Cooper's Hawk		--	T	G5	S2B	1981	1981
<i>Arethusa bulbosa</i>	Arethusa	H	--	T	G4	S2	1931	1931-06-22
<i>Arethusa bulbosa</i>	Arethusa	NR	--	T	G4	S2	1954-05-18	1954-05-18
<i>Carex exilis</i>	Coastal Sedge		--	E	G5	S1	1954	1954-07-12
<i>Conopholis americana</i>	American Cancerroot		--	T	G5	S2	2002-09-13	2002-09-13
<i>Eleocharis tuberculosa</i>	Tuberclad Spike-rush	H	--	E	G5	SH	1935	1935-08-16
<i>Gavia immer</i>	Common Loon		--	T	G5	S3B	2000-05-17	2005-07-02
<i>Gavia immer</i>	Common Loon		--	T	G5	S3B	2002-05-24	2005-07-04
<i>Glyptemys insculpta</i>	Wood Turtle		--	--	G4	S3	2004-07-17	2004-07-17
Hemlock - beech - oak - pine forest		B	--	--	GNR	S5	1984	1998-08-28
Hemlock - beech - oak - pine forest		C	--	--	GNR	S5	1985-06-26	1985-06-26
<i>Isotria medeoloides</i>	Small Whorled Pogonia	BC	T	T	G2	S2	1984	2004-08-25
<i>Isotria medeoloides</i>	Small Whorled Pogonia	D	T	T	G2	S2	1985	1992
<i>Isotria medeoloides</i>	Small Whorled Pogonia	D	T	T	G2	S2	1985	1993-09-16
<i>Isotria medeoloides</i>	Small Whorled Pogonia	D	T	T	G2	S2	1993-07-22	1998-08-28
Kettle hole bog system		A-	--	--	GNR	S2S3	1983-06-25	1998-08-25
Kettle hole bog system		AB	--	--	GNR	S2S3	2002-09-17	2002-09-17
<i>Lithophane lepida lepida</i>	Pine Pinion Moth	A	--	T	G4T3T4Q	S1S2	1985	2003-04-28
<i>Lithophane thaxteri</i>	A Noctuid Moth	A	--	--	G4	SU	1985	2003-04-20
<i>Lycia rachelae</i>	Twilight Moth		--	--	G4	S2	2003-04-20	2003-04-28
Medium level fen system		B	--	--	GNR	S3	1983-06-09	1998-08-25
Medium level fen system		B-	--	--	GNR	S3	1984-06-09	1984-06-09

**Madison Element Occurrence Records Continued**

Scientific Name	Common Name	EO Rank	Federal Protection Status	State Protection Status	G Rank	S Rank	First Observation	Last Observation
<i>Packera paupercula</i>	Dwarf Ragwort		--	T	G5	S2	1958	1958-07-09
<i>Panicum philadelphicum</i>	Philadelphia Panic Grass	H	--	E	G5	SH	1911-08-07	1911-08-07
<i>Triphora trianthophora</i>	Three-birds Orchid	NR	--	T	G3G4	S2	1984-09-21	2004-08-25

**Ossipee Element Occurrence Records**

Scientific Name	Common Name	EO Rank	Federal Protection Status	State Protection Status	G Rank	S Rank	First Observation	Last Observation
<i>Betula pumila</i>	Swamp Birch	A	--	E	G5	S1	1985-08-29	2004-09-15
Black spruce - larch swamp		B-	--	--	GNR	S3	1999-08-05	1999-08-05
<i>Calystegia spithamea</i>	Low Bindweed	H	--	E	G4G5	SH	1923	1923-06-29
<i>Carex wiegandii</i>	Wiegand's Sedge		--	E	G4	S1	1964	1964-06-30
<i>Clemmys guttata</i>	Spotted Turtle		--	--	G5	S3	1993-06-08	1993-06-08
<i>Conopholis americana</i>	American Cancerroot		--	T	G5	S2	1999-06-15	2000-09-13
<i>Conopholis americana</i>	American Cancerroot		--	T	G5	S2	2002-06-13	2002-06-20
<i>Coregonus clupeaformis</i>	Lake Whitefish	H	--	--	G5	S3	1946	1946-02-14
<i>Cuscuta pentagona</i>	Five-angled Dodder	H	--	E	G5	SH	1943	1943-08-04
<i>Eriophorum angustifolium</i>	Narrow-leaved Cotton-grass	A	--	E	G5	S1	1984-06-06	1984-06-06
<i>Eriophorum angustifolium</i>	Narrow-leaved Cotton-grass	B-	--	E	G5	S1	1997-07-08	1997-07-08
<i>Euthamia caroliniana</i>	Grassleaf Goldenrod	A	--	E	G5	S1	1993	1993
<i>Gavia immer</i>	Common Loon		--	T	G5	S3B	2004-06-25	2004-07-17
<i>Gavia immer</i>	Common Loon		--	T	G5	S3B	2001-05-24	2004
<i>Gavia immer</i>	Common Loon		--	T	G5	S3B	2005-05-28	2005-06-23
<i>Gavia immer</i>	Common Loon		--	T	G5	S3B	2000-05-17	2005-05-27
Hemlock - cinnamon fern forest		B	--	--	GNR	S4	1999-08-05	1999-09-09
High-elevation spruce - fir forest		B	--	--	GNR	S4	2000-09-07	2000-10-24
Hudsonia inland beach strand		A	--	--	GNR	S1	1971	1985
Hudsonia inland beach strand		AB	--	--	GNR	S1	1990	1990-06-09
<i>Hudsonia tomentosa</i> var. <i>intermedia</i>	Hairy Hudsonia		--	T	G5T4	S2	1978	1985-08-29
<i>Hudsonia tomentosa</i> var. <i>intermedia</i>	Hairy Hudsonia		--	T	G5T4	S2	1998-08-05	1999-10-22
<i>Hudsonia tomentosa</i> var. <i>intermedia</i>	Hairy Hudsonia	BC	--	T	G5T4	S2	1990	1990-06-09



**Ossipee Element Occurrence Records Continued**

<b>Scientific Name</b>	<b>Common Name</b>	<b>EO Rank</b>	<b>Federal Protection Status</b>	<b>State Protection Status</b>	<b>G Rank</b>	<b>S Rank</b>	<b>First Observation</b>	<b>Last Observation</b>
Isoetes lacustris	Large-spored Quillwort	H	--	E	G5	SH	1936	1936-09-02
Isotria medeoloides	Small Whorled Pogonia	D	T	T	G2	S2	1999-08-19	1999-09-08
Kettle hole bog system		A-	--	--	GNR	S2S3	1960	2005-09-14
Kettle hole bog system		B	--	--	GNR	S2S3	1990-06-09	1999-08-05
Kettle hole bog system		B+	--	--	GNR	S2S3	1998-07-07	1998-07-07
Kettle hole bog system		B+	--	--	GNR	S2S3	1998-08-13	1998-08-13
Kettle hole bog system		C	--	--	GNR	S2S3	1982-09-10	1982-09-10
Lipocarpa micrantha	Dwarf Bulrush	H	--	E	G5	SH	1923	1923-08-23
Medium level fen system		A-	--	--	GNR	S3	1998-07-07	1998-07-07
Medium level fen system		A-	--	--	GNR	S3	1997-07-16	1998-08-05
Mixed pine - red oak woodland		A	--	--	G3G4	S1	1982-10-14	1982-10-14
Panax quinquefolius	Ginseng	H	--	T	G3G4	S2	1948-05-28	1948-05-28
Pitch pine - scrub oak woodland		B-	--	--	GNR	S1S2	1999-07-20	1999-08-31
Poor level fen/bog system		A-	--	--	GNR	S3	1985-08-29	1998-08-05
Poor level fen/bog system		B-	--	--	GNR	S3	1998-07-30	1998-07-30
Poor level fen/bog system		B+	--	--	GNR	S3	1998-09-15	1998-09-15
Potamogeton nodosus	Knotty Pondweed		--	E	G5	S1	1962	1962-06-29
Potamogeton pusillus ssp. gemmiparus	Budding Pondweed		--	E	G5T3	SH	1974	1974-08-07
Potamogeton pusillus ssp. gemmiparus	Budding Pondweed		--	E	G5T3	SH	1979	1979-08-23
Progne subis	Purple Martin		--	E	G5	S1B	2003-07-10	2004-06-13
Proserpinaca pectinata	Mermaidweed	NR	--	E	G5	SH	1968	1982-09
Red maple floodplain forest		AB	--	--	GNR	S2S3	1998-07-15	1998-07-29
Red oak - black birch wooded talus		B-	--	--	GNR	S3S4	2000-09-13	2000-10-24
Red oak - pine rocky ridge		B+	--	--	GNR	S3S4	2000-09-13	2000-09-13
Sandy pond shore system		A	--	--	GNR	S2	1971	1985
Sandy pond shore system		B	--	--	GNR	S2	1990	1990-06-09
Sphagnum riparium	Peat Moss	NR	--	T	G5	S2	1997	1997
Sugar maple - beech - yellow birch forest		B-	--	--	G5	S5	2000-10-24	2000-10-24
Temperate minor river floodplain system		B+	--	--	GNR	SNR	1998-07-30	1998-07-30
Winterberry - cinnamon fern wooded fen		B-	--	--	GNR	S4	1997-07-08	1999-10-01

### Tamworth Element Occurrence Records

Scientific Name	Common Name	EO Rank	Federal Protection Status	State Protection Status	G Rank	S Rank	First Observation	Last Observation
<i>Apharetra dentata</i>	A Noctuid Moth	A	--	--	G4	S2	1985-07-17	1985-07-17
<i>Carex exilis</i>	Coastal Sedge		--	E	G5	S1	1969	1969-06
<i>Chordeiles minor</i>	Common Nighthawk		--	T	G5	S2B	1983	1996
<i>Conopholis americana</i>	American Cancerroot	B	--	T	G5	S2	1952	1999-09-20
<i>Cypripedium parviflorum</i> var. <i>pubescens</i>	Large Yellow Lady's Slipper	H	--	T	G5T5	S2	1888	1888-05-13
<i>Cypripedium parviflorum</i> var. <i>pubescens</i>	Large Yellow Lady's Slipper	H	--	T	G5T5	S2	1946	1946-06-02
<i>Eleocharis tuberculosa</i>	Tuberclad Spike-rush	X	--	E	G5	SH	1923	1946-08-18
<i>Erynnis brizo brizo</i>	Sleepy Duskywing	A	--	--	G5T5	S2	1985	1985-05-23
<i>Eumacaria latiferrugata</i>	A Geometrid Moth	A	--	--	G4	S2S4	1983	1985-05-23
<i>Euthamia caroliniana</i>	Grassleaf Goldenrod	B	--	E	G5	S1	1953	1993
<i>Gavia immer</i>	Common Loon		--	T	G5	S3B	2000-05-17	2005-06-18
<i>Gavia immer</i>	Common Loon		--	T	G5	S3B	2001-05-24	2005-07-04
<i>Glena cognataria</i>	Blueberry Gray		--	--	G4	S3?	1985	1985-05-23
Hemlock - spruce - northern hardwood forest		A	--	--	GNR	S3S4	1972	1972
Hemlock - spruce - northern hardwood forest		AB	--	--	GNR	S3S4	1973	1973
<i>Isoetes lacustris</i>	Large-spored Quillwort	H	--	E	G5	SH	1917-08	1917-08
<i>Itame</i> sp. 1 nr. <i>inextricata</i>	Pine Barrens Itame		--	--	G3G4	S1S2	1985-07-17	1995-07-06
Kettle hole bog system		B+	--	--	GNR	S2S3	1998-08-06	2006-04-12
<i>Listera cordata</i>	Heart-leaved Twayblade	NR	--	T	G5	S2	1939	1939-07-11
<i>Malaxis unifolia</i>	Green Adder's Mouth	H	--	T	G5	S2	1915-09	1915-09
<i>Malaxis unifolia</i>	Green Adder's Mouth	H	--	T	G5	S2	1888 08 10	1947-07-19
<i>Panax quinquefolius</i>	Ginseng	NR	--	T	G3G4	S2	1938-09-08	1938-09-08
Pitch pine - scrub oak woodland		B-	--	--	GNR	S1S2	1971	2006-04-12
<i>Poecetes gramineus</i>	Vesper Sparrow		--	--	G5	S2S3B	1996	1996
<i>Spizella pusilla</i>	Field Sparrow		--	--	G5	S3	1996	1996
<i>Toxostoma rufum</i>	Brown Thrasher		--	--	G5	S3	1996	1996
<i>Triphora trianthophora</i>	Three-birds Orchid	B	--	T	G3G4	S2	2004-08-30	2004-09-08
<i>Triphora trianthophora</i>	Three-birds Orchid	NR	--	T	G3G4	S2	1880-08-17	1932-09-17
<i>Triphora trianthophora</i>	Three-birds Orchid	NR	--	T	G3G4	S2	1940-08-30	1940-09-10
<i>Utricularia resupinata</i>	Reversed Bladderwort	NR	--	T	G4	SH	1888	1971-09-03
<i>Utricularia resupinata</i>	Reversed Bladderwort	NR	--	T	G4	SH	1971-08-29	1971-08-29

**Tamworth Element Occurrence Records Continued**

<b>Scientific Name</b>	<b>Common Name</b>	<b>EO Rank</b>	<b>Federal Protection Status</b>	<b>State Protection Status</b>	<b>G Rank</b>	<b>S Rank</b>	<b>First Observation</b>	<b>Last Observation</b>
<i>Xestia elimata</i>	Southern Variable Dart Moth		--	--	G5	S3S4	1995-08-01	1995-08-01
<i>Xylena thoracica</i>	Pinion Moth	A	--	--	G4	S2	1985 04-15	2003-04-28
<i>Xylotype capax</i>	Barrens Xylotype	A	--	--	G4	S2	1985	1985-10-05
<i>Zale obliqua</i>	A Noctuid Moth		--	--	G5	S2	1985 08-02	1995-07-06
<i>Zale sp. 1 nr. lunifera</i>	A Noctuid Moth		--	--	G3G4	S1	1985 05-23	2003-05-20
<i>Zale submediana</i>	Noctuid Moth	A	--	--	G4	S3	1985	2003-05-20
<i>Zanclognatha martha</i>	Pine Barrens Zanclognatha Moth		--	T	G4	S1	1985 08-14	1995-08-01

**Sandwich Element Occurrence Records**

<b>Scientific Name</b>	<b>Common Name</b>	<b>EO Rank</b>	<b>Federal Protection Status</b>	<b>State Protection Status</b>	<b>G Rank</b>	<b>S Rank</b>	<b>First Observation</b>	<b>Last Observation</b>
<i>Ammodramus savannarum</i>	Grasshopper Sparrow		--	T	G5	S1B	2002-07-05	2002-07-21
<i>Gavia immer</i>	Common Loon		--	T	G5	S3B	2000-05-27	2005-06-23
<i>Juncus secundus</i>	One-sided Rush	NR	--	E	G5?	SH	1932-08-31	1932-08-31
<i>Malaxis unifolia</i>	Green Adder's Mouth	H	--	T	G5	S2	1921	1921-07-03
<i>Poecetes gramineus</i>	Vesper Sparrow		--	--	G5	S2S3B	2001-06-03	2002-07-05
<i>Potamogeton pusillus</i> ssp. <i>Gemmiparus</i>	Budding Pondweed	NR	--	E	G5T3	SH	1971-08-25	1971-08-25
Red oak - pine rocky ridge		B	--	--	GNR	S3S4	1993	1999-07-27
<i>Senna hebecarpa</i>	Wild Senna	H	--	E	G5	S1	1885	1885-08-20
<i>Utricularia resupinata</i>	Reversed Bladderwort	NR	--	T	G4	SH	1971-08-25	1971-08-25

### **Appendix III to Biodiversity: Methodology for Designating Matrix Forest Blocks**

Conservation groups, including The Nature Conservancy and many partners, have identified and prioritized matrix forest blocks for conservation through a four step process:

- 1. Identify potential blocks through a GIS (*Geographic Information Systems*) analysis.** The boundaries of potential blocks were defined by significant fragmenting features including roads, major utility corridors, railroad lines, and shorelines of very large lakes.
- 2. Refine block boundaries through maps, photos, site visits, and expert opinion.** Blocks meeting minimum size criteria, were further analyzed by inspecting topographic and road maps, aerial photos, satellite imagery, and expert interview to check the validity of the GIS-created block boundaries. Significant changes were made to many of the blocks to better reflect the realities on the ground.
- 3. Collect and analyze ecological and other data on the block.** Evaluation and prioritization of blocks was accomplished by analyzing a variety of GIS data, including road miles and density, land cover, topographic classes, geology, lakes and ponds, streams and rivers, dams, rare species and natural community occurrences, and conservation lands. Local experts were also consulted to better understand the overall condition of the forest, management history, and presence of old growth or other unusual natural features in the blocks.
- 4. Select blocks for conservation action.** Blocks were selected as priorities based on their embedded biodiversity, regional significance, viability, and conservation feasibility.

**Ossipee Watershed Coalition**  
**Natural Resource Planning Guide**  
**Chapter V – E: Forests**

**I. INTRODUCTION – WHY ARE FORESTS IMPORTANT?**

New Hampshire's forests provide many direct and indirect benefits to our state, and those within the Ossipee Watershed are particularly important. In this Guide, it is important to look at both the forest ecosystem as a whole, and the resource management of the major economic forest product, timber (i.e., forestry). Ossipee watershed towns can manage their forest land using land use (i.e., zoning) and protection methods, but the management of private timber lands are accomplished by consulting foresters, the application of Best Management Practices (BMPs) and resource harvesting regulations that are managed by the State. This section strives to offer a perspective on the resource management (forestry) aspect as well as the forest ecosystem as a whole.

**Forestry** is a complex science practiced by professionals, and is focused primarily upon sustaining the integrity of forest ecosystems. Harvesting forests is but one segment of forestry. Forest management should emulate the natural life cycle processes of the forest, with foresters working to enhance the growth and productivity of the forest. The involvement of trained foresters in forest management and harvesting is critical since the State only regulates water-body and aesthetic harvest buffers. The following will help provide a basic understanding of the importance of forests and the practice of forestry in New Hampshire:

- Forests do not need foresters. Foresters can be crucial in sustaining the integrity of forest ecosystems while providing resources for landowners and communities that depend upon them.
- A poorly planned and executed timber harvest can drastically decrease the productivity, health and earnings potential of a forest for generations to come.
- During a timber harvest, as much debris (limbs, dead trees, defective logs, etc) as possible should be left on the ground. These materials are the compost of the forest, and provide the basis for much of the forest's food chain. Tree roots are fed by soil fungi. What happens below ground is as important as what happens above ground.
- Mature, diseased and overcrowded trees gradually die in the forest, and therefore, we can imitate nature by harvesting some of these trees.
- Natural, small forest openings occur in New England due to wind, disease mortality, and fire. Today, these natural forces are largely pre-empted by human concerns. Forest management can provide these small openings to help preserve biological diversity.
- Forest-based manufacturing contributes 8% of NH's manufacturing and employs 9400 people.
- Forests are a renewable, locally controlled source of energy, supplying about 6% of NH's electrical and heating energy.
- The forest contributes economic value to the state through personal income, real estate values, and tax revenue. Forestry related activities contributed \$3.9 billion to the NH economy.

- Much of the tourism, recreation and second home activity, is also forest-based. The overall annual contribution of open space related activities in NH was \$8.2 billion in 1996/7. This comprised about 25% of the state's gross state product.

The **Forest Ecosystem** is the interrelationship among the forest vegetation (trees and their understory), animals, soil, groundwater, air and sunlight. This is a very complex relationship and a full description is beyond the scope of this Guide. There are many resources (see "Resources" listed later in this Chapter) to help explain forest ecosystems and their importance in NH. Some key aspects of a forest ecosystem are:<sup>1</sup>

- A forest in New Hampshire is naturally composed of various species of trees and shrubs of many different age groups. These layered forest canopies, and their associated herbaceous groundcovers, are of great importance to many wildlife species. See also Chapter V.D. Biodiversity and Chapter V.C. Contiguous Open Space and Wildlife.
- The trees best suited to the soils, moisture levels, and slopes on a particular forest site grow best there, and will become the dominant species on these sites over time. Good forest management can facilitate and maintain this outcome, as well as control damaging affects to the soils and slopes.
- See also Chapter V.F. Soils and Chapter V.H. Elevations and Viewsheds.
- Forests provide the best protection for both ground and surface water quality. The forest land base plays a vital role in supplying clean water for our public drinking supplies and thousands of private wells also benefit from the retention of forest cover. Forests also attenuate flood waters and moderate stream flow throughout the year, a service that otherwise requires costly engineering. See also Chapters V.A. Water Resources.
- Forest biomass and forest soils can play a significant role in carbon storage, particularly when wood products have a long lifespan and are substituted for other carbon-based, energy-intensive products such as steel and plastic. Conversion of forests to development releases significant amounts of carbon into the atmosphere. Strategies to increase carbon storage and reduce emissions based upon U.S. wood use, forest management, forest retention and replanting could equal between 20 and 40% of the carbon being emitted annually in the United States.
- Species biodiversity in NH is dependent on the quality of our forests. NH is home to 1606 vascular plants, 34 of which are at risk globally, and 434 vertebrate animals, 8 of which are at risk globally. Most of these species depend upon healthy forest habitat for at least part of their life cycle. See also Chapter V.D. Biodiversity for more details.
- Standing dead trees are of great benefit to many wildlife species. Forests filter out pollutants and moderate air temperature for shaded buildings and streets, improving health, energy conservation, and comfort. See also Chapter V.D. Biodiversity.
- Our forests provide scenery, exercise, and emotional and spiritual renewal for visitors and residents. They are part of the quality of life that NH residents value. See also Chapter VI. Economics, Tourism and Growth.

---

<sup>1</sup> Thorne and DL Sundquist, 2001. New Hampshire's Vanishing Forests: Conversion, Fragmentation and Parcelization of Forests in the Granite State. Society for the Protection of New Hampshire Forests. 164pp.

In order to avoid unnecessary redundancy in the Guide, the reader is referred to other sections that relate to important aspects of forest ecology, as well as the risks and recommendations related to it. An understanding of these ecological resources as they relate to forests is critical to effectively managing land use within the watershed's towns. The relevant sections are referred to throughout this chapter.

The remainder of this Chapter, then, addresses Forestry, since it is such a major aspect of forest land economics and land use. Again, if a town wishes to protect some forest land from the potential for broad-scale harvesting, then land conservation tools are available to do that (see "Resources" at the end of this chapter; and also Recommendations in Chapters V.C. and V.D.).

Caring for our complex forests is a responsibility we have to future generations. A forest takes from 80 to 110 years to mature in NH. Ecosystem and financial needs derived from our forests are always a significant factor in forest management. These needs and responsibilities can be better met by making good land use planning and forestry decisions.

## II. DESCRIPTION OF FOREST RESOURCES

Carroll County is blessed with an abundant source of highly productive forests. New Hampshire is 83% forested. A total of 93% of Carroll County's land area is forested. This extensive land base of both white pine and northern hardwoods, with oak present throughout, has ensured that forestry is a critical component of the local economy with respect to both the forest products industry and tourism. Tourism is the largest industry with forestry being a close second. A recent statewide study has revealed that 900 million tourist dollars are attributed to our forested landscape and all the recreation opportunities that are derived from this resource. With respect to our forest industry, private forest landowners, consulting foresters, logging contractors, truckers, primary and secondary forest industries derive all or part of their income from the sustainable management of our forest land.

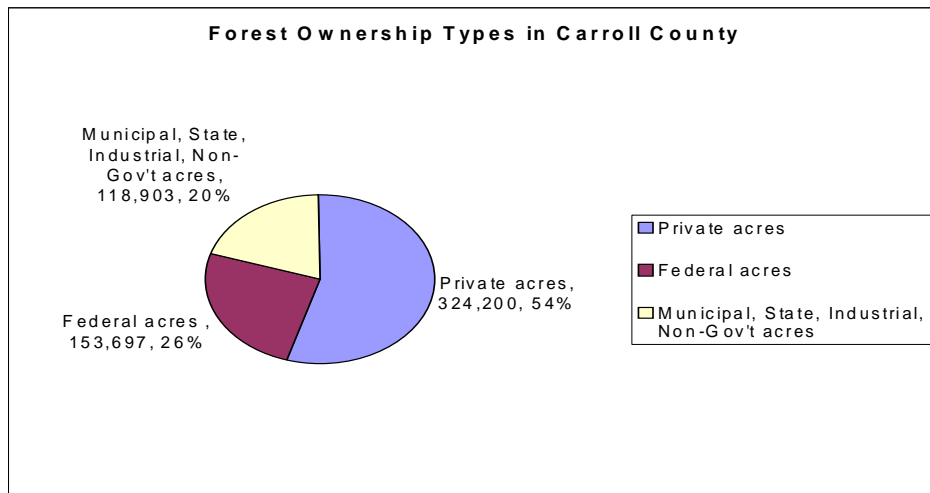

Chapter V-E, Figure 1

Over half (54%) of the forested land in the county, totaling 324,200 acres, is privately owned. Federal ownership comprises about 25% or 153,697 acres. The remaining land, consisting of 21% of the landscape or 118,903 acres, is owned by municipal, state, industrial or non-governmental owner-ships. The economic value on the annual forestry activities from forest land in the county is estimated to be approximately \$302,575,000.

According to the latest forest inventory conducted in 1997, we currently have a predominantly middle aged, older forest growing across much of the state. Younger, regenerating forests make up less than 10% of our timberland. Again, our wildlife populations are responding to this situation with many early successional species (those animals that depend on young, shrubby openings for some part of their life cycle) significantly declining in numbers.

A worthwhile goal is to have a diverse, healthy, well-connected forest habitat to support not only forest products, but to support wildlife habitat and to protect our water quality and quality of life. This can be achieved through thoughtful planning and management of our forest resources. Protection of key parcels to connect habitats together is also warranted as development pressures take more land out of forest.

Because our forests are so abundant (or have such a dominant presence in the landscape) we can overlook the many benefits that healthy functioning forests provide to us:

- NH’s forest products industry contributes \$ 1.7 billion dollars to the state’s economy.
- Logging generates \$37 million in financial return to NH landowners (approx 4,000 harvests/ year).
- Almost \$4 million in timber tax is returned to NH towns (in Carroll County >\$423,000 in 2005).
- Forests provide the backdrop for tourism – NH’s number one industry.
- Each acre of forestland generates \$313 per acre of economic activity in the forest products industry (The Economic Importance of NH’s Forests, NEFA 2001).
- Every \$1 value in a standing tree has the potential to add (using hard maple as an example) \$27 in value. Simply manufacturing a log into lumber increases the wood value six times.
- Our forests provide habitat for wildlife, recreational opportunities (cross country skiing, fishing, hiking) for residents and visitors, and they filter our water.
- 80% of NH participates in wildlife-related activities from birding to hunting (NH FRP, 1996).
- Growing forests remove carbon dioxide from the air – sustainable forestry can help to slow the increase of greenhouse gases in our atmosphere.

Northern hardwoods (made up primarily of sugar maple, beech, yellow birch, red maple and white ash) are one of NH’s more common forest cover types. In Carroll County, nearly half of forest land has this general species make-up. That is followed by oak/hickory which includes hickory and red maple (and up to 25% white pine), and white/red pine (white pine, red pine or eastern hemlock make up most of the stocking. Associates include: red maple, oak, sugar maple and aspen).

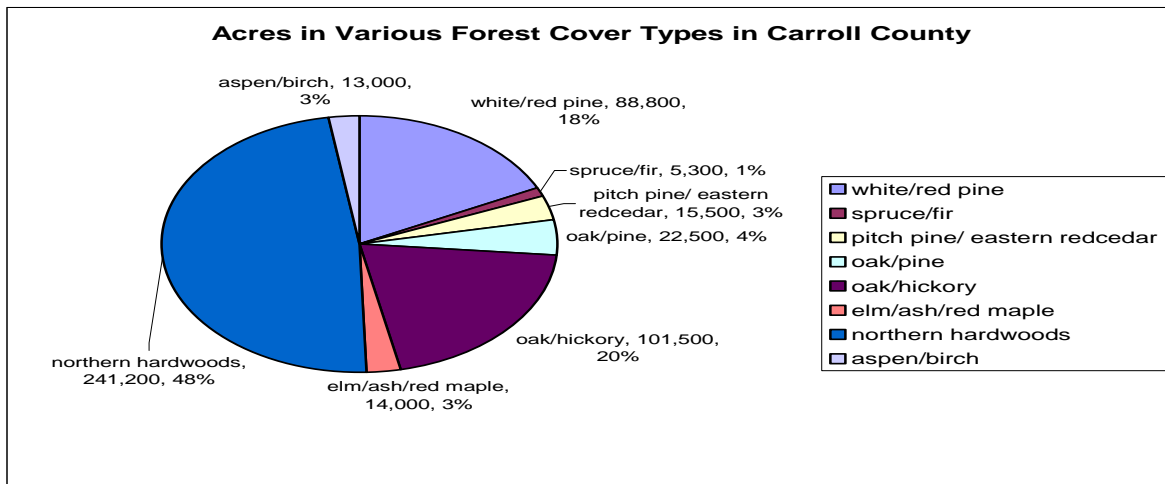



In addition to these broader reaching forest cover types, we are also fortunate to have a number of unique forest and habitat types in the county including: pitch pine barrens, peat bogs, and floodplain forests.

### III. THREATS TO FOREST RESOURCES

There are a number of threats to the retention of our rural landscape and a lifestyle which so many individuals cherish. Trends such as increased population, fragmentation of the forest resource base, poor management practices, and changes in land ownership all affect the ability of NH's forests to meet the diverse needs of its people. Global competition has affected some of our local and regional mills. In addition, as a result of global transportation and trade, we have inadvertently introduced plants, insects and diseases that have had devastating impacts on some of our native forest species.

#### A. Population, growth, development and fragmentation

NH's population grew 17.2% between 1990 and 2004 – twice the rate of the rest of New England<sup>2</sup>. Residential development has accompanied this growth. Each year, it is estimated that NH loses approximately 17,000 acres of forest land to development. To put this into perspective, 17,000 acres is an area roughly 2/3's of the size of the town of Effingham. Unlike past conversion of NH's forests to farmland and pasture, today's conversion is more permanent. In addition to directly losing land to houses, roads, and utilities, the sprawling nature of much of this development fragments remaining open spaces leaving them less suitable for forestry or wildlife habitat (See also Chapters V.C. and D.).

Forest fragmentation into small units makes it more difficult to practice forestry. Smaller parcels are less economical to manage. Also, as woodland parcels are intermingled with residential uses, timber harvesting often becomes less acceptable. Recreational values and wildlife habitat are impacted by smaller lots. As land changes and moves from undeveloped toward more developed, many species fall out of the landscape, unable to meet their needs in the smaller, undeveloped areas (Table 1).

Chapter V-E, Table 1

Habitat Block Size Requirements For Wildlife in This Area				
<b>Tier 5 1 – 19 Acres</b>	<b>Tier 4 20 – 99 acres</b>	<b>Tier 3 100 – 499 acres</b>	<b>Tier 2 500 – 2500 acres</b>	<b>Tier 1 Undeveloped</b>
Raccoon	Raccoon	Raccoon	Raccoon	Raccoon
	Hare	Hare	Hare	Hare
				Coyote
Small Rodent	Small Rodent	Small Rodent	Small Rodent	Small Rodent
	Porcupine	Porcupine	Porcupine	Porcupine
				Bobcat
Cottontail	Cottontail	Cottontail	Cottontail	Cottontail
	Beaver	Beaver	Beaver	Beaver
				Black Bear
Squirrel	Squirrel	Squirrel	Squirrel	Squirrel
	Weasel	Weasel	Weasel	Weasel
		Mink	Mink	Mink
				Fisher
	Woodchuck	Woodchuck	Woodchuck	Woodchuck

<sup>2</sup> New Hampshire's Changing Landscape, 2005

		Deer	Deer	Deer
Muskrat	Muskrat	Muskrat	Muskrat	Muskrat
			Moose	Moose
Red Fox	Red Fox	Red Fox	Red Fox	Red Fox
Songbirds	Songbirds	Songbirds	Songbirds	Songbirds
		Sharp-Shinned Hawk	Sharp-Shinned Hawk	Sharp-Shinned Hawk
			Bald Eagle	Bald Eagle
Skunk	Skunk	Skunk	Skunk	Skunk
		Cooper's Hawk	Cooper's Hawk	Cooper's Hawk
		Harrier	Harrier	Harrier
		Broad-Winged Hawk	Broad-Winged Hawk	Broad-Winged Hawk
			Goshawk	Goshawk
		Kestrel	Kestrel	Kestrel
			Red-Tail Hawk	Red-Tail Hawk
		Horned Owl	Horned Owl	Horned Owl
			Raven	Raven
		Barred Owl	Barred Owl	Barred Owl
		Osprey	Osprey	Osprey
		Turkey Vulture	Turkey Vulture	Turkey Vulture
		Turkey	Turkey	Turkey
Most Reptiles	Most Reptiles	Reptiles	Reptiles	Reptiles
	Garter Snake	Garter Snake	Garter Snake	Garter Snake
	Ring-Neck Snake	Ring-Neck Snake	Ring-Neck Snake	Ring-Neck Snake
Most Amphibians	Most Amphibians	Most Amphibians	Amphibians	Amphibians
		Wood Frog	Wood Frog	Wood Frog

One of the major causes of fragmentation is the escalation of land prices. Land prices have raised an average of 61% since 1998 (NH's Changing Landscape 2005). The cost of land throughout New Hampshire far exceeds the ability of the land to produce a comparable value of forest products. Most of NH's land is privately owned, and if an owner chooses to maximize profits, then that is often done by not growing trees but by growing houses.



**Chapter V-E, Figure 3**

1952  
Moore's Pond/ Silver Lake Area  
Tamworth/Madison

1970  
Moore's Pond/Silver Lake Area  
Tamworth/Madison

2003  
Moore's Pond/ Silver Lake  
Tamworth/Madison

## B. Poor Management Practices

There is a significant difference between purposeful timber harvesting and indiscriminant cutting. Before timber is harvested, the landowner needs to be clear what outcome they intend and do a thorough assessment of harvesting actions ahead of time: know what resources are there and develop a thoughtful plan that will help meet harvest objectives. The failure to make this assessment can result in degradation of water quality and resource values. Municipal officials can help connect landowners with the existing network of professionals available to help them with their land management.

Often, the public reaction to a highly visible timber harvest is emotionally charged as people feel a sense of loss of their familiar surroundings. This reaction can lead to calls for regulation of timber harvesting to prevent such events from occurring in the future. Some of this timber harvesting is the result of a landowner harvesting mature timber as part of a well-thought out series of activities identified in a long term management plan. Other times, this harvesting is a precursor to subdivision and development, or it is a harvest based upon generating the maximum income at a point in time with little or no consideration of future growth and regeneration (high grading). While the motivations of landowners may be unclear, attempts to further regulate timber harvesting can negatively affect those landowners managing their lands responsibly and reduce their ability to manage and even to hold onto their lands. While timber harvesting can be visually disruptive, our forests are very resilient, and trees will grow back if given the opportunity. This opportunity is lost when the land becomes developed. Landowners have tremendous flexibility in what they can do with their land. An informed landowner is the key to the sound management of our landscape. Again, municipal officials can help landowners understand the steps to sustainable management.

## C. The rapid turn over in land ownership

According to the USDA Forest Service, forests change owners on average every 10-15 years. In contrast, a forest management plan may take decades to implement. Multi-generational ownership of land is no longer as common as it used to be, making it especially challenging to reach new owners before it is too late and their property has been mismanaged.

NH's owners are also aging. "A recent USDA Forest Service survey of private landowners found that the percentage of New Hampshire landowners who are retired jumped from 15 to 40 percent between 1983 and 1994. They now hold nearly 1.5 million acres of New Hampshire forest land. This means that 40 percent of the land owners – or more than one fourth of the forest land in the state will change owners in the next 25 years." (NH Forest Resources Plan, 1996).

## D. Globalization and the loss of markets and infrastructure to carry out both the harvesting and processing of products harvested from our forests

Without a work force available and engaged in the harvesting of trees there will be little to no management and no real need for primary and secondary processors. To maintain a viable forest products industry in the future, we need: 1) the land base, 2) infrastructure, and 3) industry. At the very least, a threshold level of forest industry is necessary to be adaptive and responsive to future markets and opportunities.

## E. Climate change and invasive species

Numerous non-native species have been introduced to our landscape. Some of these introduced species have had significant consequences for our native plants. Chestnut blight has nearly eliminated this valuable species (it was valuable both for its lumber and for its production of mast for wildlife) while Dutch elm disease, gypsy moth, and spruce budworm represent other examples of well known health threats to our forests and trees. More recently, the hemlock woolly adelgid has advanced northward after killing vast numbers of hemlock trees to our south. There are two other pests (Asian long-horn beetle and emerald ash borer) that could wreak havoc if they arrive. [Not all introduced species (for example apple trees and honey bees) “invade” and disrupt our natural systems].

Diversity in terms of species and age classes is important to keep forests resilient as pest impacts are often less severe in mixed forests.

Climate is an important factor influencing which plant species will survive and thrive in an area. According to NH DES, ecological models are predicting that NH will experience warmer temperatures and more extreme weather events as a result of global warming. Potential impacts for NH forests include the decline and increased mortality of some species and improved growing conditions for others. Disturbances such as pest and pathogen outbreaks, flooding, and wind damage are also expected to increase (NH DES, Impacts of Climate Change).

## **IV. CURRENT REGULATIONS AND PRACTICES FOR LAND MANAGEMENT**

### A. Current Regulations

NH has a series of timber harvesting laws that are designed to protect our resources. In addition there are voluntary practices that landowners and resource professionals use to protect water quality and aesthetics as well as to minimize the risk of wildland fires.

In 1989, the legislature recognized that increased local regulation of forestry related activities could threaten our working forests and passed an amendment to the local planning and zoning enabling legislation (RSA 672:1, IIIc) that provides, “... forestry activities, including the harvest and transport of forest products, shall not be unreasonably limited by use of municipal planning and zoning powers or by the unreasonable interpretation of such powers.”

#### *1. Timber Tax Law (RSA 227-J:5)*

The value of timber has been separated from the value of land for taxation purposes. Land is taxed annually, while timber is not taxed until it is harvested. When timber is harvested, a 10% tax is assessed on the value of the timber harvested.

Before timber can be harvested from a property, an Intent to Cut form is filed by the landowner with the town. This form identifies the land, owner, and expected timber to be harvested. Once approved by the town, a certificate will be issued which should be posted at the harvest site. Once harvesting is complete (or at the end of the reporting year) a Report of Cut is filed with the Town. A tax bill is generated based upon the timber value.

When an Intent to Cut Form is filed with the town, the town must sign the intent within 30 days. An Intent to Cut cannot be held up by town officials for a road bond.

The only reasons an Intent to Cut form may be held for greater than 30 days and not acted upon include:

1. All owners of record have not signed the form
2. The land is in the “Unproductive” Category in Current Use
3. The Intent to Cut form is inaccurate or incomplete
4. A required timber tax bond has not been received.

### 2. *Basal Area Law (RSA 227-J:9)*

The basal area law requires that forested buffers be left along town and state roads, streams and bodies of water, following a timber harvest. These buffer zones can prevent erosion, provide wildlife habitat, protect stream temperature and aquatic life, and preserve the aesthetics of the landscape. It applies to land conversion and clearing unrelated to forest management unless all state and local permits necessary for the conversion have been secured. No more than 50 percent of the basal area may be cut each year within certain distances of ponds, streams, and public roads. Basal area is a measure of forest density.

### 3. *Slash Law (RSA 227-J:10)*

Slash is the debris that remains after timber is harvested. These branches, leaves and wooden stems may take several years to decompose. Slash, in addition to its messy appearance can increase the risk of wildland fire. The slash law limits where logging slash may be left. No slash may be left within rivers, streams and brooks that flow year round. Slash may not be left along public roads or railroad beds, on someone else’s property, in cemeteries, or within 100 feet of most structures. Slash may not be stacked more than four feet high within certain distances of water bodies and public roads.

### 4. *Operations in Wetlands (RSA 227-J:6)*

A permit is required from DES before anyone can excavate, remove, fill, dredge, or construct any structures in or on any bank, flat, marsh, or swamp in or adjacent to any waters in NH (RSA 482-A).

For timber harvesting purposes, filing an Intent to Cut along with the appropriate notification of forest management activities having minimum wetlands impact with the DES and the DRED, satisfies the permitting requirements for minimum impact activities (RSA 82-A:3, V).

NH DES also requires that skid trails, truck roads and culverts, bridges, pole fords, or other crossings be constructed using Best Management Practices for Erosion Control on Timber Harvesting Operations in New Hampshire (NH DRED).

Either a copy of the notification or a dredge-and-fill permit from the NH Wetlands Board must be on site. These are not required if no wetlands are present, but a significant percentage of logging jobs in NH can be expected to encounter some type of wetland or stream crossing.

One of the considerations on the wetlands permit application is the presence of threatened or endangered species in the vicinity of the proposed operation. The NH Natural Heritage Inventory maintains a database identifying known occurrences of listed threatened and endangered species. Currently, a system is being developed to check all wetlands applications against this database to determine if projects have the potential to impact any listed species. If a species is identified in the area of the proposed operation, then the full dredge and fill application (as opposed to the expedited forestry one) may be required to proceed.

### *5. Alteration of terrain permit 227-J:7*

Anyone proposing to dredge, excavate, place fill, mine, transport forest products, or undertake construction in or on the border of surface waters of the state, and any person proposing to significantly alter the characteristics of the terrain, in such a manner as to impede the natural runoff or create unnatural runoff shall comply with the provisions of RSA 485-A.

For forestry operations, the Notice of Intent to Cut serves as the alteration of terrain permit. If the land is being converted to non-forest uses then an alteration of terrain permit from the Division of Water Supply and Pollution Control must be on site if more than 100,000 square feet (50,000 square feet in protected shoreland zone) of terrain are being converted to non-forest uses.

### *6. Prime Wetlands*

In Carroll County, communities with designated prime wetlands include: Sandwich, Tamworth, and Wolfeboro. Prime wetlands are areas with high value functions which are mapped and adopted by a town and approved by NHDES. All projects that are in or adjacent to a prime wetland are classified as major projects. All major projects require a field inspection by DES and all prime wetland projects require a public hearing to be conducted by DES. If you are working in or adjacent to a prime wetland, you cannot use the notification of forest management or timber Harvesting Activities having Minimum Wetlands Impact, you must file a different wetlands application. Contact the DES Wetlands Bureau (603) 271-3503 for additional information.

### *7. Minimum Shoreline Protection Standards regarding Timber Harvesting - RSA 483-B*

The new Shoreline Protection Standards will be coming into effect April 1, 2008. It changes the determination of how many trees can be cut within the 50' set-back from the water reference line; uses the NH hydrography dataset to determine 4<sup>th</sup> order streams (adds almost 100 new water bodies); there will be no exclusions to the 50' buffer (towns that had grandfathered set-back less than 50' are now no longer to have that); limits non pervious surfaces to 20% of the land within the protected shoreland (250') back from the water reference line, permits will be required for all disturbance within the shoreland protection zone, etc. This restriction is applicable to operations around year round flowing waters of fourth order or higher, all fresh water bodies greater than 10 acres in size and tidal areas.

### *8. Timber Trespass (RSA 227-J:8)*

Timber can be worth thousands of dollars. As such, it can be a tempting target for unscrupulous operators. In addition to the law as described below, it is important that landowners know where their boundary lines are and mark or have them marked accordingly.

The Timber Trespass Law provides a means for landowners to recover the value of trees (with penalties) for unauthorized removal of trees from their property. Civil and criminal penalties may be assessed. 227-J:8 Trespass; Civil Penalty states that, "I. No person shall negligently cut, fell destroy, injure, or carry away any tree, timber, log, wood pole, underwood, or bark which is on the land of another, or aid in such actions without the permission of that person or the person's agent." The landowner may be entitled to receive remuneration of between 3 and 10 times the market value of the trees cut.

If you suspect timber has been stolen from your property consider the following questions:

1. Do you know where your boundary lines are?
2. Are your property lines marked?
3. Has the property been recently surveyed?
4. Do you have a map?
5. If the theft occurred through the property of another, have you contacted the abutter?

After considering the above, contact the NH Division of Forests and Lands at 603-271-2217.

### *9. Deceptive Forestry Business Practices (RSA 227-J:15)*

Buying and selling forest products can be confusing and occasionally deception occurs. Therefore, it is important that all parties involved have a clear understanding of how the wood will be measured, what the prices are, and how each party will be paid. A written contract, with mutually agreed-upon prices and amounts, is strongly recommended.

The Deceptive Forest Business Practices Act protects landowners from individuals who give a false or incomplete accounting of wood removed, misrepresent the products removed or services provided, or do not remunerate a timber owner for the value of the forest products removed in accordance with their written timber sale contract. A landowner is entitled to ask for and receive all scale slips to verify the amount of forest products removed from their property. (Scale slips contain information about the species of wood, board feet of each log (or tonnage or cords if wood is measured on that basis), gross and net scale, defect, date wood was measured and name of the party scaling the wood).

NH Division of Forests and Lands District Forest Rangers are available to help landowners determine their course of action if timber trespass or deceptive forestry practices are suspected.

#### *Written Contracts are Now Required for Harvesting Timber*

It is very difficult for the State to assist landowners with deceptive forestry business practice issues when landowners do not have a written contract. In the 2007 Legislative Session, NH passed HB 440. One of the provisions of this bill is that it requires individuals buying and selling forest products to provide a written contract to the landowner prior to cutting forest products from the property. The contract must be signed by both parties, specify the remuneration for the forest products to be sold, and specify the time when payment will be made. This provision should make it easier to prosecute cases of deceptive practices. Landowners should be encouraged to tailor a timber sale agreement to their specific needs. Among the things they should consider including in a timber sale agreement are:

- Does the operator have adequate insurance?
- What is the duration of time the operator has to complete the job?
- Are there conditions when you do not want the operator working? Wet soils etc...
- What condition do you require the skid trails and roads to be left in following the harvest?
- Are the products being marketed to bring the landowner the best value?
- How will the slash be handled?
- Who is responsible if a forest fires starts as a result of the operation?
- How will trees be designated for removal?
- Who is responsible for repairing stone walls, bridges, fences etc that may result from logging?
- How will you address damage to remaining trees?
- Under what conditions may the contract be terminated?

### *10. Scenic Roads (RSA 231:157)*

Scenic Roads are local town designations. Any road in a town (other than Class I or Class II highways) may be designated as a Scenic Road upon petition and subsequent approval by voters. Designation as a Scenic Road means that repair, maintenance, and reconstruction work to the roadway should not involve the cutting or removal of trees 15" or more in diameter or the tearing down or destruction of stone walls without prior written consent of the planning board or board responsible for the local scenic roads program. There are exemptions to this for the prompt restoration of utility service and for trees that pose an "imminent threat" to the traveling public. The Scenic Roads designation does not affect the rights of abutting landowners.

*11. Boundary Line Trees (RSA 472:6)*

Boundary markers should not be moved or removed. This includes moving a stone wall that serves as a boundary and cutting trees with boundary markings (blazes) on them. Boundary trees may only be cut when there is mutual agreement between all landowners whose property lines are affected by the moving of the boundary marker.

*12. State Temporary Driveway Permits*

All access from a State highway for timber harvesting requires a Temporary Driveway Permit and a bond, unless access is granted through an existing permitted driveway that can safely handle the trucking. Bonding may be waived if the applicant has consistently conformed to previous permitting requirements. The Temporary Driveway Permit must also stipulate a time limit. Therefore a previously used entrance is not valid unless a new permit has been obtained from the NH DOT district engineer. These permits are required by the State to assure sight distance for safety, drainage, protection of the edge of the pavement (both for potential breakup of the pavement and tracking mud and snow and other debris onto the pavement surface), and restoration of the ditch line, pavement, and drainage from the site at the end of the timber cutting. NH Highway District 3 covers all of Carroll County except Jackson, Bartlett and Hart's Location Tel: 603 524-6667. For Bartlett, Jackson and Hart's Location, contact NH District 1, Tel: 603-788-4641.

*13. Town Temporary Driveway Permits*

Some towns may require a temporary driveway permit to access timberlands for a logging operation. The process and standards vary depending upon the municipality.

*14. Road Bonds*

A bond is a form of insurance that protects the town from unnecessary damage which may occur to the public highway. Road bonds are authorized under RSA 236:9-236:12 when permission is sought to disturb the ditches, shoulders, embankments or improved surface of a town road and under RSA 236:190 and 236:191 when permission is requested to exceed weight limits placed on the road.

**Chapter V-E, Table 2 (Excerpted from Forest Products Road Manual)**

State Law	Forestry	Land Conversion
Notice of Intent to Cut (RSA 79)	Required, some exceptions apply	Required when cutting greater than 10 MBF and 20 cords
Dredge and Fill Permit (RSA 482-A)	Required if wetlands impact is minor or major	Required if wetlands impact is minimum, minor, or major
Wetland Forest Management Minimum Impact Notification (RSA 482-A:3)	Required if wetlands	Can't be used
Alteration of Terrain (RSA 485-A:17&	Required if > 100,000 sq ft. is disturbed, or 50,000 sq ft within shoreland protection zone (RSA 483-B:9,V)	Required, but Notice of Intent to Cut Timber/Timber Certificate serves as permit (RSA 485-A:17,III)
Basal Area Law (RSA 227-J:9)	Applies unless variance has been obtained from NH Division of Forests and Lands	Applies unless all local permits have been secured
Slash Law (RSA 227-J:10)	Applies	Applies
Comprehensive Shoreland Protection Act (RSA 483-B:9, V)	Not Applicable	Applies within 150 feet of public waters



### **Timber Sale Checklist – Things for landowners to consider**

Have you clearly identified your property boundaries?

Do you have a contract for your timber harvest to protect your interests?

*Many of the laws designed to protect you aren't enforceable without a written contract.*

Is a licensed forester involved?

Have you filed your intent to cut?

Did you keep an adequate number of trees along public roads, streams and water bodies?

Is the debris (slash) from your harvest away from structures, streams and roads?

Do you have/ need a wetlands notification?

Does your town have any locally designated wetlands?

How will your forest land be left after the harvest?

Will this harvest accomplish YOUR objectives for your land?

### **What to look for at the site**

A certificate from DRA should be posted at the site (or a copy of the notice of intent to cut signed by the assessing officials) (or a copy of the notice of intent to cut with the operation number, along with the date, time, and name of municipal official or employee who provided the operation number).

Either a Confirmation of Complete Forestry Notification (wetlands) or a Dredge and Fill Permit should be posted at the site. They are not required if no wetlands or surface water bodies are present. If no form or permit is present, and you believe one is required, you should contact the Wetlands Bureau.

A well distributed stand of healthy trees along roads (including Class VI roads). If trees have been completely removed along the road, the Division of Forests and Lands should be contacted to determine whether the landowner has applied for a variance to the basal area law. If the land is being converted to non-forest uses, the basal area may not apply, but local boards and officials should be contacted to see that the appropriate local permits have been obtained.

In general, there should be no large piles of slash near roads or lakes. Slash and slash piles may be present when cutting takes place in these areas, but should be removed promptly. When this condition is not met, contact the Division of Forests and Lands.

If the owner is disturbing (damaging) a public highway (including Class VI, permission must be sought under RSA 236:9.

*From: Guide to New Hampshire Timber Harvesting Laws, UNH Cooperative Extension, 2004*

## B. Voluntary Encouragements For Land Management

### *1. Current Use*

The intent of the Current Use Program is to preserve open space by assessing the land based on present use rather than highest potential use. "Current use value" means the assessed valuation per acre of open space land based upon the income-producing capability of the land in its current use, and not its real estate market value. Current Use is an important statute that has allowed N.H. to remain as rural as it is. It ensures an affordable annual tax that permits the continuation of farming and forestry operations.

Current Use land categories include farmland, forestland, unproductive land, and wetlands. A minimum of 10 acres is required to qualify for Current Use (except for wetlands). Lands that are open for public recreational activities can qualify for a further reduction in assessment. Forest land can be assessed in the forestland category or in the forest land with documented stewardship category. If the use of the land is changed so that it no longer qualifies for Current Use status, it is subject to a land use change tax. This tax is the equivalent of 10% of the full and true value at the time of change.

### *2. UNH Cooperative Extension County Forestry Assistance Program*

The UNH Cooperative Extension Forestry and Wildlife Program has been caring for NH's forests since 1925. Their mission is to help NH's citizens make informed natural resource management decisions. UNH Cooperative Extension helps landowners with woodlot care, long term planning, selling timber, wildlife habitat, estate planning and land protection, current use taxation, and more.

UNH Cooperative Extension has a professional forester in each of the ten counties and forestry, wildlife, and industry specialists and program coordinators located at the university. In Carroll County, contact Wendy Scribner, County Extension Forester at (603) 539-3331.

### *3. Tree Farm*

The American Tree Farm System is a nationwide program that encourages private forest owners to actively manage their forests in a sustainable manner for multiple values. A Tree Farm is a privately owned forest managed to produce timber with added benefits of improved wildlife habitat, water quality, recreation, and scenic values. There are also municipal watersheds, school forests and other public ownerships certified as Tree Farms. In NH, over 1,500 Tree Farmers manage more than 500,000 acres. To qualify as a Tree Farmer, a landowner must: dedicate at least 10 acres to growing and harvesting forest products; have a written plan for future management of their forest; follow the management recommendations prescribed by a licensed forester; and demonstrate a commitment to stewardship of their forest for multiple values.

### *4. Best Management Practices*

Best Management Practices (BMPs) are used to protect water quality during timber harvest operations. BMPs include a wide range of recommended techniques that can be used before, during, and after logging operations to maintain the integrity of the ground. Harvest sites can vary significantly, so having a variety of techniques to choose from can help landowners and resource professionals choose the best approach on a given site. BMPs are designed to protect the environment and prevent pollution problems. They are mandatory in some situations; others may be voluntary, depending on the site. If forestry management or harvesting activities involve impacts to wetlands or surface waters (by traveling across them), BMPs are mandatory and a NH DES Forestry Notification may be required.

### *5. Forester Licensing (RSA310-A:98-117)*

There are 280 licensed foresters in the state, many of whom provide a variety of forest resources management services to NH's private landowners. Foresters must be licensed by the State to offer forestry services to the public for compensation. Licensing requires certain educational and experience levels as well as commitment to continuing education. The objective of forester licensing is to maintain a high standard of forestry practices in the state.

### *6. Voluntary Logger Certification Program*

Over 300 loggers are now certified through NH's voluntary Professional Loggers Program. To become certified, participants complete educational programs in: first aid and CPR, safe and productive felling practices, NH timber harvesting law, and fundamentals of forestry. The program is designed to help loggers improve work efficiency, safety and environmental awareness, and to improve awareness and compliance with timber harvesting and wetlands laws and regulations. Loggers take additional educational courses to maintain their certification. Some mills require their suppliers to be certified before purchasing their wood.

### *7. 'Good Forestry in the Granite State' Recommendations*

Good Forestry in the Granite State: Recommended Voluntary Forest Management Practices for New Hampshire is a guide to provide landowners and professionals practical recommendations on sustainable management practices for individual forest ownerships. The manual covers topics including: soil productivity; water quality, wetlands and riparian areas; habitat; unique and fragile areas; timber quality/flow; and aesthetics and visual quality/recreation. The science of forestry continues to evolve as scientists and professionals learn more about the complex interactions occurring in our forests.

### *8. Permanent Land Protection*

In the last six years, NH communities have designated \$140 million dollars to protect important open spaces. Community groups, land trusts and other organizations have worked together to protect important local resources using local, state and federal funds and working with landowners who are interested in donating easements. Many projects require having willing buyers and willing sellers.

An important first step in the process of protecting lands using conservation easements is to identify those lands which are important to the community (such as productive farmlands, a key viewshed, or a unique natural area), because even with the most aggressive land protection program there is not enough funding to protect everything (and this is probably not a reasonable objective given the need to accommodate human population growth). Geographic information systems (GIS) data and local knowledge of priority areas in need of protection are important to successfully protecting key elements of our natural environment.

Many easements are written to allow for forest management. Working forest easements can protect land from development while at the same time allowing it to be managed for forest products, wildlife habitat, recreation, scenery, and water protection.

## **V. RECOMMENDATIONS**

While loss of forest land and fragmentation of our forest base is a significant challenge, we cannot expect to stop development entirely. The challenge is to plan for both conservation and development. We also have a challenge to manage our lands responsibly and sustainably. Some areas are better suited to development while others are more critical for their natural open space benefits. Protecting large,

unfragmented blocks and connecting habitat areas to allow for wildlife movement are important considerations to maintain a full array of wildlife species in our landscape. Unique natural communities and habitats required by species that are threatened, endangered or of conservation concern should be identified. We also need to pay particular attention to soils as our food and forest products will grow best on the more productive soils.

#### A. Educate Landowners to Encourage Informed Decision Making

Towns can be a force for education for landowners. As noted earlier in this chapter, there is a wealth of information available to help landowners make management decisions that have a long-term impact on their land. For example, the town of Ossipee provides an information packet to all landowners who come in for an Intent to Cut application. This packet includes information about NH's timber harvesting laws and wetlands requirements, and also informs people about the assistance available through the UNH Cooperative Extension County Forester.

Encourage landowners to work with natural resource professionals and to develop stewardship plans. Developing a plan takes a landowner through the process of thinking about their objectives for their property. They learn about what is there, and what actions they can take to work toward their objectives. A recent study found that 73% of NH landowners (owning 10+ acres) do not have a management plan. For most landowners, timber harvesting happens infrequently on their property. Yet timber harvesting can leave a long term legacy (good or bad).

Many towns own land and have land designated as town forests. These community-owned resources can be a great educational asset to demonstrate long-term stewardship and management. Towns actively managing their lands and working with professional foresters can play an important role in demystifying the process and outcome of responsible management. Town and county owned forests can also be managed as recreational assets with hiking and cross country ski trails.

***“Forest Laws for Municipal Officials” – an educational brochure for municipal officials produced by the UNH Cooperative Extension Service.***

#### B. Educate Our Youth

As noted above, NH's forests contribute significantly to NH's economy and quality of life. Recent studies have shown that youth are less connected to the world around them. Often they are more aware of environmental issues in places such as the tropical rainforests than they are about the forests and resources of their own backyards. These children will be the voters and decision makers of tomorrow.

Connection with the natural world also has health implications. Research suggests that, “... exposure to nature may reduce the symptoms of Attention Deficit Hyperactivity Disorder (ADHD), and that it can improve all children's cognitive abilities and resistance to negative stresses and depression.”<sup>3</sup>

Programs such as New Hampshire Project Learning Tree use NH's forests to introduce key environmental concepts to students. PLT activities are designed to help students learn to think critically and creatively about their relationship to the natural world. PLT is noted for teaching students how to think about the environment, not what to think.

---

<sup>3</sup> Richard Louv, Last Child in the Woods, 2006 (pg 34)

*NH Project Learning Tree trains and supports educators through introductory and advanced professional workshops. In addition, many Tree Farmers and natural resource professionals are available to help teachers and students learn about and visit forests in their local communities. Contact [www.nhplt.org](http://www.nhplt.org) for more information.*

## C. Apply Good Management Practices

### *1. Use Professionals*

While foresters typically charge their fee as a percentage of the timber sale income, research has shown that landowners who use the services of a licensed forester are overall more satisfied with the results of their timber sales, they receive more income, and they have more trees remaining when the harvest is finished than landowners who do not utilize their services.

### *2. Use BMPs*

Best Management Practices protect the productivity of our soils and protect our streams from sedimentation. Whether clearing land for development, harvesting timber, or creating trails on property, good planning and installation of simple erosion control practices can reduce and eliminate many water quality problems.

### *3 Have a Management Plan*

Assemble good information about your land, your ownership objectives and the steps needed to meet your objectives for the land.

### *4. Some Indicators of Good Management*

When harvesting timber, recognize that a timber harvest is a major disturbance in the forest landscape. Even a “good” harvest may not look very appealing. However, there are 5 things to look for during a harvest that are indicators of a “good” operation.

a. Minimum residual damage – The worst thing that can happen during careless logging is to damage the younger mid-size trees that will be the crop for the next harvest. A wound to the trunk of a tree is a serious injury that dramatically lowers the timber value of that tree forever. A few “bumper trees” on the corners of the skid trails are acceptable, but widespread trunk damage to many trees scattered throughout the property should not be tolerated.

b. No Soil Ruts – If the logging equipment is causing deep ruts in the soil, the property is being logged at the wrong time of year. Sensitive sites need a high degree of pre-harvest planning and should be logged mid-winter, when the ground is frozen, or during mid-summer when the ground is dry. Rutting creates excessive tree root damage and soil erosion on steep slopes, both of which are long term negative impacts on the productivity of the forest.

c. Low Stumps – More than half the lumber value of each tree is in the first log, so it makes sense to cut the stumps as low as possible. Even during winter harvests with deep snow, the logger is expected to shovel or plow out around each tree so that it can be cut low to the ground.

d. Low Slash – The limbs, tree tops and unsellable small wood remaining after a harvest is called “slash”. If this is run over by the skidder or cut close to the ground by the chainsaw operator, it is less offensive visually, and will rot faster, returning nutrients to the forest floor. Also, if trails are to be used for recreation, care should be taken to clear these of logging debris by the end of the harvest. Note: There are a few instances when “high slash” is specifically warranted. For

example, in areas with high deer populations, high slash will protect the tree seedlings from excessive feeding by deer.

e. No Waste – Full utilization of all the products harvested is the optimum goal, even though it may take innovative marketing on the part of the harvester. Anyone can sell good quality, high value logs. It is the large volume of low value logs that is challenging to move from the property.

#### D. Apply Conservation Easements/land protection options where appropriate

Land conservation is becoming a priority in many communities. A recent poll conducted by UNH Survey Center (for the SPNHF) found that 85% of NH adults think their city or town should invest public funds to protect farms, forest land and other open space. In the last 6 years, NH communities have appropriated over \$140 million dollars for open space and land conservation projects.

The Governor's Commission on New Hampshire in the 21<sup>st</sup> Century found that conventional two to five acre lot zoning does more to fragment land than to protect it. As minimum lots sizes increases, development sprawls further across the landscape. While the intention behind larger lot sizes may be to slow growth, it has the unintended consequence of spreading it out more, and consuming more land. In Maine, local governments are recognizing that this dispersed population growth, in addition to consuming more open space, is resulting in increased community costs for schools, buses, roads and public safety.<sup>4</sup>

Numerous planning and zoning techniques are available for communities to consider conserving important open spaces. *Open Space for New Hampshire: A Toolbook of Techniques for the New Millennium* by Dorothy Tripp Taylor provides a good summary of many of these techniques.

As our population increases we will need to accommodate and plan for that growth. Rather than stop growth, we need to direct it so that we maintain ecologically significant lands, large contiguous blocks of land, and corridors to connect them.

## **V. Resources and Sources of Information**

### A. Resources

There are many resources available to help people be good stewards of their land. The following agencies are involved in forestry related activities in NH:

**Department of Revenue Administration** – responsible for NH Timber Tax (603) 271-2687.  
<http://www.nh.gov/revenue/property>

**Division of Forests and Lands - State Forest Rangers** should be notified about any potential violations of NH Timber Harvesting Laws. (603) 271-2214. <http://www.nhdf.org>

**Division of Forests and Lands - New Hampshire Natural Heritage Bureau** – locates, tracks, and provides information about rare plant species and ecosystems in the state. Authorized under the Native Plant Protection Act (RSA 217-A) the program is not regulatory; instead, it works with landowners, land managers, and natural resource professionals to help them understand and protect the State's natural heritage and meet their land use needs. (603) 271-2214

---

<sup>4</sup> The Cost of Sprawl, Maine State Planning Office, May 1997

**Department of Environmental Services- Water Division** - ensures that New Hampshire's lakes and ponds, rivers and streams, coastal waters, groundwater and wetlands are clean and support healthy ecosystems, provide habitats for a diversity of plant and animal life, and support appropriate uses.  
– Wetland Bureau (603) 271-2147 <http://www.des.nh.gov/wetlands>

### **UNH Cooperative Extension**

The University of NH Cooperative Extension Forestry and Wildlife Program has been caring for New Hampshire's forests since 1925. Our mission is to educate New Hampshire's citizens about rural and urban forest environments, enhancing their ability to make informed natural resources decisions.

The University of New Hampshire Cooperative Extension has a professional forester in each of the ten counties and forestry, wildlife, and industry specialists and program coordinators located at the university.

We help landowners with woodlot care, long term planning, selling timber, wildlife habitat, estate planning and land protection, current use taxation, and more. We help communities through support to town boards, public officials, schools, civic groups, and other community organizations. We help provide a healthy working landscape by offering the state's 84,000 landowners, 1400 loggers, 250 licensed foresters, and 100 sawmills information and technical assistance. We cosponsor the NH Coverts and Community Tree Stewards volunteer programs and the NH Tree Farm Program, the NH Timber Harvesting Council, and the Professional Loggers Program. The University of New Hampshire Cooperative Extension provides New Hampshire citizens with research-based education and information, enhancing their ability to make informed decisions that strengthen youth, families and communities, sustain natural resources, and improve the economy.

In Carroll County, call (603)539-3331. <http://www.extension.unh.edu>

**Private Licensed Foresters** – for a listing contact UNH Cooperative Extension.

<http://www.extension.unh.edu>. To learn more about forester licensing, you can also visit the NH Joint Board of Licensure at <http://www.nh.gov/jtboard/fr.htm>

**Certified Loggers** - visit the NH Timberland Owners Association at <http://www.nhtoa.org>

## B. Sources of Information

**Natural Resources Conservation Service** <http://www.nh.nrcs.usda.gov/>

NRCS provides trained soil conservationists, technicians, soil scientists, agronomists, engineers, economists, biologists, foresters and other experts to help landowners and land users with conservation. NRCS administers a variety of cost-share programs to help landowners plan, design, and install conservation practices.

**New Hampshire Fish and Game Department** <http://www.wildlife.state.nh.us/>

NH Fish and Game has developed a Comprehensive Wildlife Action Plan to provide New Hampshire decision-makers with important tools for restoring and maintaining critical habitats and populations of the state's species of conservation and management concern. It is a pro-active effort to define and implement a strategy that will help keep species off of rare species lists, in the process saving taxpayers millions of dollars. The plan identifies species and habitats at risk as well as conservation strategies. A series of maps have been developed to help communities identify important wildlife habitat resource areas.

**Society for the Protection of New Hampshire** – [www.forestsociety.org](http://www.forestsociety.org)

The Forest Society is dedicated to protecting the state's most important landscapes while promoting the wise use of its renewable natural resources. The forest society protects and manages land throughout the state, promotes good land stewardship through education and by example, and advocates for public policies that encourage the wise conservation of natural resources.

**New Hampshire Timberland Owners Association** <http://www.nhtoa.org>

The NHTOA is a non-profit statewide coalition of landowners, forest industry professionals, government officials, and supporters who work together to promote better forest management, conserve our working forests, and insure a strong forest products industry.

The Nature Conservancy - The mission of The Nature Conservancy is to preserve the plants, animals and natural communities that represent the diversity of life on Earth by protecting the lands and waters they need to survive. The Nature Conservancy is actively protecting the Ossipee Pine Barrens. <http://www.nature.org>

### **Local Land Trusts** operating in (parts of) Carroll County

Chocorua Lake Conservation Foundation  
Lakes Region Conservation Trust  
Green Mountain Conservation Group  
Upper Saco Valley Land Trust  
Dan Hole Pond Watershed Trust  
Squam Lakes Association  
Squam Lakes Conservation Society  
Roland Park Land Trust

*Note: This is only a partial listing of agencies and organizations that work on natural resource issues in NH.*

## **VI. Model Ordinances**

### **A. Guidance on Regulatory and Zoning Actions**

#### *1. Conservation Easements/ land protection options*

Support land conservation (See also Chapter V-C. Contiguous Open Space and Wildlife and Chapter V-D. Biodiversity)

One way for towns to raise money is to designate 100% of the Land Use Change Tax they receive to go into a land conservation fund. The Land Use Change Tax is paid when land comes out of current use. The tax is 10% of the fair market value of the land, so even with 100% of this money going toward land protection, towns will only be able to protect a small amount of land compared to what is being developed in the town, but it is a start. Towns can also bond money.....

For wildlife consider protecting large, unfragmented blocks and corridors to connect protected lands together. This allows animals to move and not become isolated. Large block of forest land are also managed more efficiently and economically than many smaller parcels. Management is important to provide forest products and to keep our forests diverse and healthy.

There are definitely areas that warrant a forever wild status. Significant acreage in the county is classified as Wilderness and will guarantee that nature will take its course on these sites. It is, however, just as important to retain large blocks for management purposes so that we ensure a healthy mix of different age classes so vital to the maintenance of a healthy and diverse wildlife population and a supply of raw materials for our fiber needs. Other benefits to management include increased recreational opportunities and water resources.



Results of NH Cost of Community Services Studies						
Community	Date of Study	Population	Land in Open Space	Cost per Dollar of Income		
				Residential	Commerical Industrial	Open Space
Alton	1999	3,500	55%	\$0.92	\$0.54	\$0.52
Brentwood	2002	3,197	54%	\$1.17	\$0.24	\$0.83
Deerfield	1994	3,200	52%	\$1.15	\$0.22	\$0.35
Dover	1993	25,500	35%	\$1.15	\$0.63	\$0.94
Exeter	1997	13,000	25%	\$1.07	\$0.40	\$0.82
Fremont	1994	2,700	64%	\$1.04	\$0.94	\$0.36
Groton	2001	339	71%	\$1.01	\$0.12	\$0.79
Lyme	2000	1,537	78%	\$1.05	\$0.28	\$0.23
Meredith	1999	5,000	40%	\$1.06	\$0.48	\$0.29
Mont Vernon	2004	2,034	62%	\$1.03	\$0.04	\$0.29
Peterborough	1997	5,600	55%	\$1.08	\$0.31	\$0.54
Stratham	1993	5,200	35%	\$1.15	\$0.19	\$0.40
Sutton	1998	1,479	72%	\$1.01	\$0.40	\$0.21

(Chapter V-E, Table 3, Information for this section from: The Dollars and Sense of Saving Special Places).

It is important for municipal officials and citizens to understand that open space pays its own way. Cost of community services studies look at the impacts of various land uses on municipal finances. Thirteen NH communities have conducted these studies, which look at the income and expense ratios for three land use types: residential, combined commercial-industrial, and open space. In every community studied, open space cost less in services than it generated in income. Residential land use, however, almost always required more in services than it generated in income. This suggests that conserving selected open spaces means lower taxes in the long run.

### 2. Understanding Forest Regulations

The reader is referred to Section IV, above, for a list of regulation related to timber harvesting and woodlot management. Municipal officials are strongly encouraged to take advantage of workshops provide by the UNH Cooperative Extension Service, such as: *Forest Law Workshops for Municipal Officials* (<http://extension.unh.edu/Forestry/documents/laws07.pdf>).

### 3. Town Ordinances

As described above, there are numerous state laws designed to protect the integrity of our soils, wetlands and water resources, for leaving forested buffers along our roads, rivers and ponds, and to reduce wildfire danger. The District Ranger with the NH Division of Forests and Lands is responsible for ensuring compliance with these laws.

Often a significant development or timber harvest in a visible location prompts community members to consider further regulating forest management at the local level. The application of additional forestry regulations at the local level has the potential to result in over 200 different regulations that resource professionals will need to know and to manage lands accordingly. If our goal is to have well managed forests contributing to our economy and quality of life we need to recognize the implications of numerous, potentially conflicting local ordinances. Forest landowners need to be able to generate some income from the management of their land to be able to continue to provide the open space that is so valuable to the community.

Often aesthetics and harvest quality are not consistent. A harvest may look bad, but may actually be scientifically sound and part of a long-term sustainable plan. On the other hand, a harvest may look nice, with a scattering of trees left, but it may be detrimental to the health of the forest because only poor quality trees with little or no value were left to continue to grow and reproduce on the site. It is very difficult to evaluate the quality of forest management by its appearance. Local level ordinances also carry with them a burden of enforcement. The key steps that a Town can undertake, then, are spelled out above, and include:

- Ensure State regulations are followed
- Ensure that private land owners understand the importance of BMPs and that their practice is important to the town.
- Have local Land Use regulations in place that help protect forests (see above and Recommendations in the Chapter V.D. Biodiversity, for example)
- Strongly urge land owners to involve a registered forester in their timber management and harvesting. Failure to follow this practice is the key reason for poor private forest conditions in Carroll County.
- Undertake local education efforts on a regular basis

Informed landowners make better decisions. Connecting landowners with natural resource professionals and the network of agencies and organizations that can help them manage their lands has the best chance of making good management happen on the ground.

B. Fully support Best Management Practices (BMPs): See Section V.C., above.

**Ossipee Watershed Coalition  
Natural Resource Planning Guide  
Chapter V- F: Soils**

This chapter is currently being developed and will appear in this location in subsequent editions of the Guide.

**Ossipee Watershed Coalition  
Natural Resource Planning Guide  
Chapter V – G Agriculture**

**I. Introduction: Why is Agriculture Important?**

Agricultural land in Carroll County has always been at a premium. The topography and soil types generally associated with large scale agricultural production are scarce at best. Agriculture is important to New Hampshire not only in the production of local food and fiber, but also in the secondary benefits to local citizens and visitors alike. Open space, scenic vistas and recreational opportunities are available in greater number due to agricultural activities. Additionally, when our food is produced locally it is fresher and reduces the burden to our planet from transporting food long distances.

**II. Description of the Resource**

According to the 2002 Census of Agriculture (Table 1), there are 229 farms in Carroll County, with a total of 29,785 acres identified as farm land. The average size of a farm in Carroll County is 130 acres, but farms range in size from 1 to 1000 acres.

**Chapter V-G, Table 1  
2002 Census of Agriculture Data  
Carroll County, NH**

<u>Item</u>	<u>Data</u>
Farms	229
Land in Farms (acres)	29,785
Ave. Size of Farms	130
Total Crop Land	6,581
Market Value of Ag Products	\$4,130,000

Recent trends in agricultural production in Carroll County and across the state have shown a decrease in traditional farm enterprises and a shift to part-time lifestyle farms. Other changes in New Hampshire agriculture have been the increase in the nursery and landscape industries, which are now the leading form of agricultural production state-wide.

In 1950, 4 out of every 10 rural people lived on a farm, and almost a third of the nation’s rural workforce was engaged directly in production agriculture. Because agriculture dominated the social and economic well-being of most of the rural population, public policy related to agriculture was a dominant force shaping rural life both on the farm and in rural communities. But today, rural America is vastly different from the 1950s, and current commodity-based farm policies do not fully address the complexities of rural economies and populations. Farm households depend more on off-farm income, and rural communities look for non-farm sources of economic growth. Today, less than 10 percent of rural people live on a farm, and only 14 percent of the rural workforce is employed in farming.<sup>1</sup>

**III. Current and Potential Impacts and Opportunities**

Agriculture is the cornerstone of New Hampshire’s and Carroll County’s scenic landscape and rich community heritage. Farming in New Hampshire has changed significantly as it has been forced to adapt to increasing populations and the loss of important agricultural soils to residential development.

At the same time, there has been an increase in demand for locally produced foods. The paradox of the rise in urbanization is that while the amount of agricultural land shrinks the demand for local agricultural products increases. There is a tremendous opportunity for agriculture in Carroll County.<sup>2</sup>

According to the Carroll County NRCS Soil Data website<sup>3</sup>, [http://www.nh.nrcs.usda.gov/Soil\\_Data/attribute\\_data/carroll.html](http://www.nh.nrcs.usda.gov/Soil_Data/attribute_data/carroll.html), there are a total of 259,444 acres of soils in Carroll County that fall into “farmland” classes (Table 2)

Chapter V-G, Table 2. Prime, Statewide and Locally Important Farm Soils, Carroll County, NH

<u>Farmland Class</u>	<u>Acres</u>
Total Prime Farmland Acres	10,350
Total Acres of Statewide Importance	6,576
Total Acres of Local Importance	<u>242,444</u>
Total	259,370

The local farm is frequently a diversified operation that has both a horticultural and livestock component. Diverse and complex growing systems require diverse and complex marketing streams and many of these local food producers rely on multiple marketing outlets.

The viability of local agriculture is driven by two primary advantages. First marketing revenues are returned to the farmer. In the industrialized agricultural system food travels thousands of miles, is handled multiple times and the marketing revenue goes to the non-farm economy. In the local agriculture system, food travels few miles, is frequently sold directly by the farmer to the consumer, thus the farmer reaps the retail value of the crop. Second, there is a growing demand for locally produced foods. A growing number of people are reducing their reliance on food from far away. Buying local means food is fresher, one knows where it was grown and it helps maintain the character of the working rural landscape.

#### **IV. Recommendations**

##### **A. Encourage local food production**

Preserving the capacity for local agricultural production will increase the amount of food derived revenue in the local economy. Currently the majority of each food dollar spent goes to the marketing, handling and transporting of food crops across vast distances. Having more food available locally would get more of the dollars spent into the pockets of the local producer and keep the working landscape feasible.<sup>4</sup> This action would also help reduce the “carbon footprint” (i.e., reduce the carbon dioxide emissions) to our atmosphere resulting from food being transported over much larger distances (e.g. California, etc.).

##### **B. Increase awareness of locally available foods**

Increased awareness of locally available foods will increase local food consumption and increase demand for local foods. Several initiatives exist to provide the link between locally produced foods and the consumer. According to the NH Farm to Restaurant Connection<sup>5</sup> the benefits of eating and buying local include:

- locally grown and produced food is fresher
- knowing where food comes from and who grows it
- helping to support local farmers and keep working farms profitable
- helping to preserve working farms and our rural landscape (productive farms preserve the high quality of life in NH)
- local money supports the local community

There are several state and federal agencies, as well as non-government organizations that can assist local farmers, consumers and restaurants in making the local food connection (see Section V, below).

### **C. Follow Best Management Practices**

Currently farmers in New Hampshire follow Best Management Practices (BMPs) to protect the land and water resources they depend on. These practices cover The Agricultural Handling of Fertilizer Compost and Manure <sup>6</sup>, originally prepared by the Agricultural Best Management Practices Task Force and NRCS, for the New Hampshire Department of Agriculture, Markets and Food and revised in 2002. BMPs provide guidance to landowners, town officials, state agencies and others to help maintain the state's agricultural base and to protect water quality. The 46 page BMP publication covers manure handling, compost and chemical fertilizer in relation to farm operation, natural resource conservation, water quality and human animal and plant health.

### **D. Reinforce registration and licensing requirements for pesticide and chemical use**

The Division of Pesticide Control <sup>7</sup> oversees the registration and licensing of pesticides and pesticide applicators in NH. Agricultural food producers and others are required to obtain and maintain the necessary licenses and follow the laws regarding the use of any pesticide, chemical or organic.

### **E. Utilize agricultural easements as a land use protection method**

It is important for towns to identify where their prime agricultural soils are and work with individual land owners on ways to conserve these lands. Once prime farmland is lost to development, it is lost to farm production forever. Towns may want to consult with soil scientists and GIS maps to identify where their prime agricultural soils are and then work in partnership with land owners about conservation measures to guarantee that land can be used for food production in the future. One conservation tool is the agricultural easement.

The Natural Resource Conservation Service (NRCS) Farm and Ranch Lands Protection Program is an excellent program established to work in partnership with land trusts, state and local governments, and other non-profit organizations to purchase conservation easements on farm land in New Hampshire. These easements protect agricultural land and important farmland soils by prohibiting conversion to non-agricultural uses. Since the Farm and Ranch Lands Protection Program came into existence in 1996, NRCS in New Hampshire has provided over \$15 million to support the purchase of and provide permanent protection for 6,366 acres of agricultural land on 85 farms across the state. The \$15 million in federal funds leveraged \$22.4 million in local funds and \$3.6 million in landowner contributions for a total easement value of \$41 million.

## V. **Helpful Hints/Links/Resources**<sup>8</sup>

<http://extension.unh.edu> University of New Hampshire Cooperative Extension  
[www.nh.nrcs.usda.gov](http://www.nh.nrcs.usda.gov) Natural Resources Conservation Service, New Hampshire  
<http://agriculture.nh.gov> New Hampshire Department of Agriculture, Markets and Food  
[www.nhfarmtorestaurant.com](http://www.nhfarmtorestaurant.com) New Hampshire Farm to Restaurant Connection  
NH Coalition for Sustaining Agriculture, UNH Extension contact, Nada Haddad, Extension Educator Agricultural Resources, Rockingham County;nada.haddad@unh.edu  
<http://www.nh.gov/oep/programs/MRPA/conferences/documents/BrushettSpring07.pdf> Creating a Ag Commission in your Hometown

**Conserving the Family Farm** - a manual using plain language on conservation easements and agricultural provisions, produced by the NH Coalition for Sustaining Agriculture and UNH Cooperative Extension, (603) 679-5616. 

**Scenic and Cultural Byways** - increasing direct marketing opportunities, New Hampshire Office of Energy and Planning, 603/271-2155.

**Preservation and Agricultural Easements** - please contact the **New Hampshire Preservation Alliance** for more information on easements, 603/224-2281.

**Is Your Town Farm Friendly?** - A checklist for sustaining rural character, by Gary Matteson for the NH Coalition for Sustaining Agriculture and UNH Cooperative Extension.

**Preserving Rural Character: The Agriculture Connection** - NHOSP Revised Technical Bulletin 6, by Lorraine Stuart Merrill. How to support local farming in land use policies and programs. 

**Preserving Rural Character through Agriculture: A Resource Kit for Planners** - A broad array of useful tools and techniques, compiled by the NH coalition for Sustaining Agriculture. 

**Creating an Agricultural Commission in Your Town** - Lorraine Stuart Merrill, for the NH Coalition for Sustaining Agriculture and UNH Cooperative Extension. Agricultural commissions are an effective mechanism for communities to take positive action to remain or become more farm-friendly. 

**Who's Who in New Hampshire Agriculture** - contact information for people and programs, and a brief economic overview of agriculture in New Hampshire, published by the NH Department of Agriculture, Markets and Food.

**American Farmland Trust** - online library, research, technical and policy assistance for saving family farms and farmland.

**National Agricultural Library** - online library and links to agricultural topics, including extensive history and image collections.

**Agriculture Online** - portal and search engine for agricultural subjects and programs.

 Adobe Acrobat Reader format. You can download a free reader from **Adobe**.

## VI. References

<sup>1</sup><http://www.ers.usda.gov/AmberWaves/May07SpecialIssue/Features/Policy.htm>

<sup>2</sup>The New Hampshire Farm Viability Task Force Report

<sup>3</sup>[http://www.nh.nrcs.usda.gov/Soil\\_Data/attribute\\_data/carroll.html](http://www.nh.nrcs.usda.gov/Soil_Data/attribute_data/carroll.html)

<sup>4</sup>University of Maine, College of Natural Science, Forestry and Agriculture White Papers, March 2003

<sup>5</sup>[www.nhfarmtorestaurant.com](http://www.nhfarmtorestaurant.com)

<sup>6</sup>[http://agriculture.nh.gov/divisions/markets/documents/BMPs\\_NH\\_Agriculture.pdf](http://agriculture.nh.gov/divisions/markets/documents/BMPs_NH_Agriculture.pdf)

<sup>7</sup>[http://agriculture.nh.gov/divisions/pesticide\\_control/index.htm](http://agriculture.nh.gov/divisions/pesticide_control/index.htm)

NH Coalition for Sustaining Agriculture, “*Preserving Rural Character Through Agriculture, a Resource Guide for Planners*”

<sup>8</sup>Resource list courtesy of NH Division of Historical Resources

(<http://www.nh.gov/nhdhr/programs/barns.html>)

## VII. Sample Ordinance

Creating local ordinances to further control agricultural activities may impede the production of local agricultural products, particularly if each town, each watershed has different regulations. The voiced concern is that stricter local ordinances may make it difficult or impossible to keep the tangle of rules from impeding local agriculture. There are, however, land use and conservation practices that could protect agricultural land, as outlined in the Recommendations section above. Most importantly, towns should set priorities to conserve land that supports prime agricultural soils, thus keeping these lands open for potential farming in the future..

The NH Coalition for Sustaining Agriculture’s “Preserving Rural Character through Agriculture, a Resource Kit for Planners” provides a section on “Agriculture Friendly Planning Regulations,” which can be used to promote an agricultural friendly local atmosphere. This would serve as an excellent resource for sample ordinances to help encourage and support local agricultural development. Another document released by the coalition is *Creating an Agriculture Commission in Your Hometown.*” This could also be a useful reference to town planners.

<http://www.nh.gov/oep/programs/MRPA/conferences/documents/BrushettSpring07.pdf>

New Hampshire Revised Statutes Annotated (RSA) 672:1, III-b and III-d lay out the general premises of planning and zoning in regards to farming and agricultural operations. RSA 21:34-a defines “agriculture” as specified by the state legislature.

<http://www.gencourt.state.nh.us/rsa/html/indexes/default.html>

A very helpful guidance document is *Innovative Land Use Planning Techniques: A Handbook for Sustainable Development*, with expected publication date December 2007, prepared as part of the Regional Environmental Planning Program by the NH Department of Environmental Services, the NH Association of Regional Planning Commissions, the NH Office of Energy and Planning, and the NH Local Government Center. There is a chapter in this draft document on “Agricultural Incentive Zoning” and includes sample zoning ordinance. NHDES has given the OWC permission to reproduce that zoning guidance information in this Guide (see below), with the caveat that all ordinances and regulations proposed for local adoption should be carefully reviewed by local officials and legal counsel; and, that the information below is still “draft” as of this date. This document should be read in its entirety since it gives excellent background and rationale for supporting agricultural incentive zoning.



# AGRICULTURAL CONSERVATION DISTRICT MODEL ORDINANCE

## Statutory Authorization:

- A. RSA 21:34-a Farm, Agriculture, Farming
- B. RSA 432:33 Immunity from Suit
- C. RSA 672:1(111-b) Declaration and Purpose
- D. RSA 672:1(111-d) Declaration and Purpose
- E. RSA 674:21 Innovative Land use Controls
- F. RSA 674:26 Districting Under Interim Zoning Ordinance
- G. RSA 674-32-a through c Agricultural Uses of Land

## **I. INTENT AND PURPOSE**

- A. Intent:** The Agriculture Conservation District is intended to protect areas of the community that are well suited for agriculture. It is also the intention of this ordinance to minimize conflicts between incompatible uses by directing non-farm residential uses to other districts within the community.
  
- B. Purpose:** The purposes of the Agriculture Conservation District are:
  - 1. To protect and promote the continuation of farming in areas with the most suitable soils.
  - 2. To protect and promote the continuation of farming in areas of the community that have historically contained these areas and therefore have developed compatible residential patterns and transportation infrastructure.
  - 3. To permit primarily agricultural land uses and activities.
  - 4. To separate agricultural land uses from potentially incompatible residential, commercial, and industrial development, and public facilities that may interfere with normal agricultural operations.
  - 5. To achieve the goals stated in the master plan, including preservation of rural character, continuation of agriculture, economic development, and natural resource protection.
  - 6. To preserve wetlands and natural areas associated with farms, that because of their natural physical features, are useful, as water retention and groundwater recharge areas, and as wildlife habitat; and that have an important aesthetic and scenic value, which contributes to the unique character of the community.
  - 7. To encourage the viability of agricultural soils for agricultural use.

## **II. DEFINITIONS**

For the purpose of this ordinance, certain words and phrases are defined as follows:

**[MARGIN NOTE: These definitions should be incorporated into the definition section of the ordinance, especially if the municipality decides to allow agriculture in multiple zones. See Section III for complete legal definition in New Hampshire.]**

**Accessory Structure:** Any structure including but not limited to seasonal housing for seasonal farm employees, barns, equipment storage, silage storage, farm stand, greenhouses, lath houses, and product processing centers.

**Agriculture and Farming:** agriculture and farming as defined in RSA 21:34-a.

**Agritourism:** attracting visitors to a working farm for the purpose of eating a meal, making overnight stays, enjoyment of the farm environment, education on farm operations, or active involvement in the activity of the farm which is ancillary to the farm operation.

**Farm:** any land, buildings, or structures on or in which agriculture and farming activities are carried out or conducted and shall include the residence or residences of owners, occupants, or employees located on such land. Structures shall include all farm outbuildings used in the care of livestock, and in the production and storage of fruit, vegetables, or nursery stock; in the production of maple syrup; greenhouses for the production of annual or perennial plants; and as defined in RSA 21:34-a. as amended.

**[MARGIN NOTE: A farm roadside stand shall remain an agricultural operation and not be considered commercial, provided that at least 35 percent of the product sales in dollar volume is attributable to products produced on the farm or farms of the stand owner. NHRSA 21:34-a III]**

**Farmers' Market:** means farmers' market as defined in RSA 21:34-a.

**Farm Parcel:** A tract or parcel of land devoted primarily to agricultural uses may contain a dwelling or other accessory uses.

**Farm Roadside Stand:** Means an on-farm, agricultural retail operation provided that: (A) at least 35 percent of the product sales in dollar volume is attributable to products from the farm or farms of the farm stand owner or farm stand operator; and (B) product sales not attributable to the farm or farms of the farm stand owner or farm stand operator shall be agriculturally related and may include, but not necessarily limited to, the sale of garden accessories, cheese, home crafts, cut flowers, dried flowers, value added products such as jams, jellies and baked goods from a farm stand kitchen. Proof of farm income may be required to determine conformity with these provisions.

**Farm Worker Dwelling:** A dwelling located on a farm for the purpose of housing an employee of that farm operation and his/her family. Also included in this use type would be multi-family dwelling(s) for seasonal employees in connection with an orchard or other agricultural use, which relies on seasonal employees who must be housed.

### **III. PERMITTED USES**

- A. All uses identified in RSA 21:34-a (see Section III).
- B. The following use accessory to the principal agricultural uses:
  - 1. Agritourism.

### **IV. CONDITIONAL USES**

- A. The following are conditional uses in the Agriculture Conservation District that require a conditional use permit based upon procedures, factors and conditions set forth in other regulations the community:
  - 1. Single-family dwelling units provided that:
    - a. The permit application for construction includes a scaled drawing indicating the location of the proposed dwelling relative to the surrounding parcels;

- b. The dwelling is sited on that portion of the lot which separates it as much as possible from adjacent farming, including minimizing the length of property lines shared by the residential lot and the adjoining farms used for production;
  - c. The dwelling and its lot are located on the least productive agricultural land wherever practical; and
  - d. The dwelling is sited on the smallest practical areas to satisfy the requirements of this ordinance and on-site sewage disposal requirements.
2. Farm worker dwelling, provided that this is used only to:
    - a. house a farm caretaker, or
    - b. house farm laborers.
  3. Home occupations.
  4. The conversion of a single-family dwelling to a two-or more family dwelling;
  5. Bed and breakfast inns.
  6. Conservation/open space subdivisions, provided they meet the criteria in Section 5 of this ordinance, in addition to any other criteria set forth in ordinances.

- B.** At a minimum, the following standards shall be applied when reviewing applications for conditional use permits within the Agriculture Conservation District:
1. The proposed use shall be sited upon lands that are less suitable for commercial agriculture than other agricultural lands within the district.
  2. The proposed use shall be sited on a parcel in a manner that minimizes the amount of productive agricultural land that is converted to the proposed use.
  3. The proposed use shall be located in close proximity to existing buildings whenever possible and appropriate to minimize the impact on farmland.

## **V. PERFORMANCE STANDARDS**

In general, the use of land and structures within the Agriculture Conservation District shall seek to maximize agricultural productivity. The non-agricultural use of land and structures must also conform to the following design standards that create a minimum level of consistency in lot and parcel configuration:

### **A. Design Standards**

All residences developed either on frontage lots or within a conservation/open space subdivision shall comply with the following standards:

1. All buildings, homes and structures shall be located a minimum of 100 feet from agricultural land and shall be separated by a 50-foot wide buffer strip sufficient to minimize conflicts between farming operations and residences. This buffer shall be on the land developed for the non-farming use and may consist of trees and or fencing.
2. Each structure shall be integrated into the existing landscape on the property so as to minimize its visual impact and maintain visibility of adjacent agricultural lands from public ways through use of vegetative and structural screening, landscaping, grading and placement on or into the surface of the lot.

### **B. Additional Requirements for Subdivision/Site Plan Approval**

The applicant shall comply with the minimum requirements for subdivision/site plans, and shall also submit to the planning board the following information:

1. Description or illustration of the physical characteristics within and adjacent to this site, including: prime agricultural soils, soils of state and local importance, other soils and soil characteristics, areas used for crop or other agricultural production.
2. Description of compliance with Agricultural Land and Development Standards in Section 5C-E and Site Design Standards in Section 5A.

### **C. Criteria for Review**

The planning board shall also consider whether:

1. The development is in compliance with Agricultural Land and Development Standards (Section 5D, below).
2. The development will not interfere with farming operations on adjacent lands.
3. The development is situated on the portion of the site with soils least suitable for the production of crops or livestock.
4. The development is integrated into the existing landscape through features such as vegetative buffers, and through retention of open agricultural land.

### **D. Agricultural Land and Development Standards**

1. Residential subdivision developments in the Agricultural Conservation District shall be laid out according to the Conservation Subdivision/Open Space Community standards set forth in Section \_\_\_ of this ordinance. All buildings and roads shall be located away from soils that are most suitable for agriculture (based on Natural Resource Conservation Service classifications for prime farmland soils and soils of state and local importance) to the maximum practical extent. This provision does not apply to the location of on-site septic disposal facilities that must be placed in soils meeting N.H. Department of Environmental Services rules.
2. All roads, drainage systems and utilities shall be laid out in a manner so as to have the least possible impact on agricultural lands and uses.

### **E. Maximum Number of Dwelling Units**

1. The maximum number of dwelling units permitted in an open space community in the agricultural conservation district shall be calculated based upon one unit per acre for the net developable acreage remaining once the area of all wetlands and steep slopes (in excess of 15%) have been subtracted from the total acreage of the property.
2. Under the supervision of the conservation commission, all wetlands shall be identified, and their area subtracted from the net developable acreage of the total parcel.

### **F. Required Open Land**

1. At least 50 percent of the net acreage remaining after the area of all wetlands have been subtracted shall be retained as open agricultural land. Remaining open agricultural land shall have appropriate acreage, configuration, and access to enable continued farming operations.

### **G. Protection of Open Agricultural Land**

The following standards shall apply to open agricultural land to be protected as part of the development of an open space community:

1. Farmland owners are not required to sell the part of their property that is to become permanent agricultural open space, provided that they convey the development rights of

that open space in a conservation easement prohibiting future development of this property to any of the official bodies named in Section G.2 below.

2. All remaining open agricultural land shall be permanently protected by either:
  - a. A permanent conservation easement or deed restriction conveyed to the municipality with municipal approval or to a non-profit farmland trust or conservation organization whose principal purpose is to conserve farmland and open space, or other suitable entity.
  - b. Ownership in fee simple conveyed to the municipality with municipal approval or to a non-profit farm trust, open space or conservation organization as a gift or for a consideration.
3. At a minimum, such an easement, fee simple ownership, or restriction shall entail the use of management practices that ensure existing fields or pastures will be plowed or mowed at least once every year.

**[MARGIN NOTE: An open space/conservation subdivision can either be laid out in a separate section of a community's ordinances, or the community can adopt the simpler standards set forth in the following sections.]**

## **VI. AGRICULTURAL MANAGEMENT STANDARDS**

- A. All farms are recommended to develop and keep current soil conservation and nutrient management plans in compliance with Natural Resource Conservation Service standards, where appropriate.

**Ossipee Watershed Coalition**  
**Natural Resource Planning Guide**  
**Chapter V – H: Elevations and Viewsheds**

*“The shadows round the inland sea  
 Are deepening into night;  
 Slow up the slopes of Ossipee  
 They chase the lessening light...  
 Green belted with eternal pines  
 The mountains stretch away.”*

*“The Lakeside,” John Greenleaf Whittier, 1849*

**I. Introduction: Why are Elevations and Viewsheds Important?**

The rolling sweep of forest from the villages, lakes and ponds of the Ossipee Watershed to the rounded crests of the Ossipee, Green and Sandwich mountains forms the signature vistas of this region that have made it a popular tourist destination for generations.

Now, with the U.S. Census Bureau projecting population growth of 40% to 60% by 2020 in Carroll County, the scenery that has long attracted poets, artists and tourists increasingly draws developers for homes along slopes and ridgelines that offer spectacular views out over the same landscape, and a growing challenge to preserving the region’s rural character.

**II. Description of the resource**

Definitions:

- **Ridgeline:** The linear trace of a topographic crest above a defined elevation, such as 700 feet in the Ossipee Watershed area;
- **Slope:** Gradient of land, usually averaged over 100 feet;
- **Viewshed:** A topographically defined scenic view, as seen from public roads or water bodies; also called “Viewscape” or “Skyline.”

For conservation and regulatory purposes, “steep slopes” are typically defined as land areas with gradients averaging 15% (15 vertical feet of rise for every 100 horizontal feet) or greater, as shown in Table 1:

TOWN	TOTAL LAND	SLOPE 15-25%	SLOPE OF 25%+	STEEP SLOPE ACRES
	ACRES	AREA IN ACRES	AREA IN ACRES	AS % OF TOTAL LAND
Effingham	24,827	3,019	2,325	21.5%
Freedom	22,058	4,822	2,429	32.9%
Madison	24,647	4,666	1,692	25.8%
Ossipee	45,079	7,210	4,102	25.1%
Sandwich	58,166	10,938	10,557	37.0%
Tamworth	38,121	6,279	4,297	27.7%

Chapter V – H Table 1 – Watershed Towns Number of Steep Slope Acres as a % of total Land

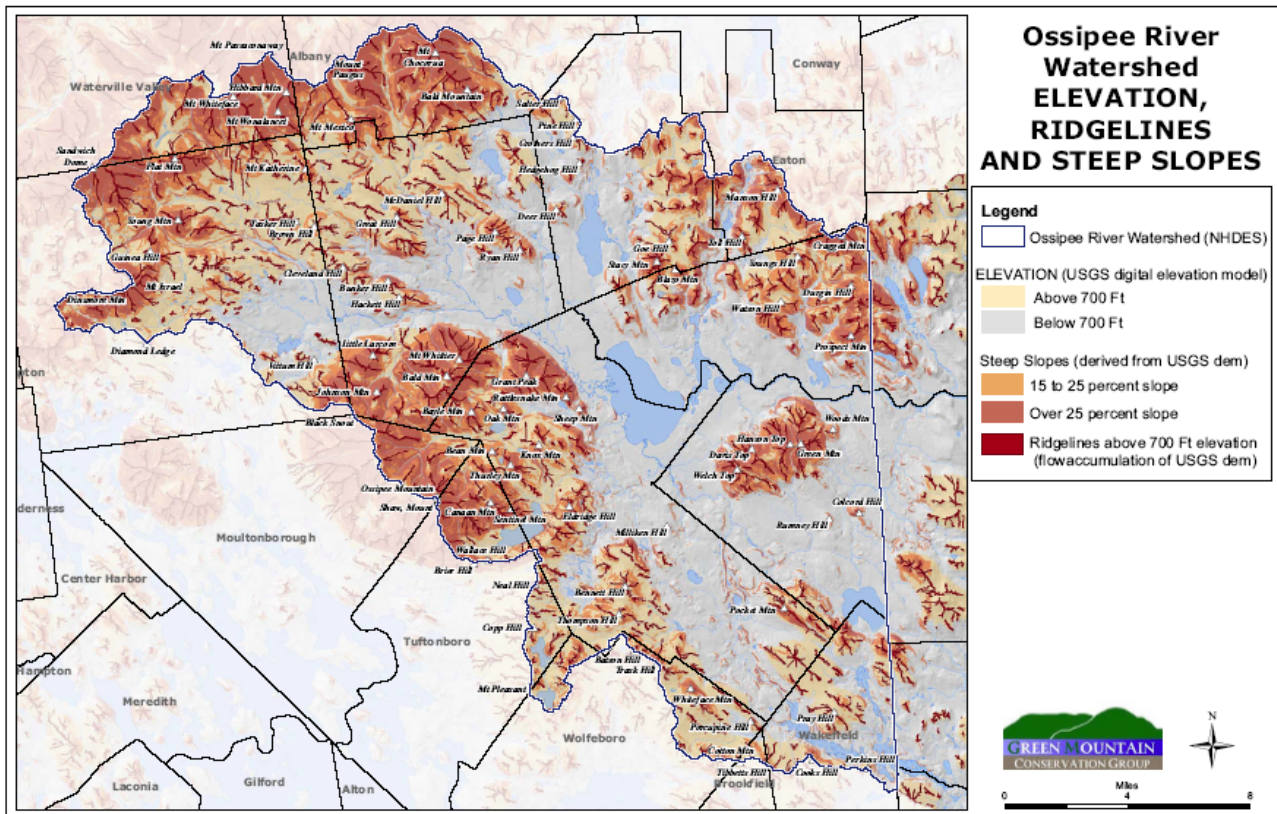

**Chapter V H Figure 1 – Ossipee River Watershed Elevation, Ridgelines and Steep Slopes**

As the map in Figure 1 shows nearly all the steep slope areas in the six towns of the Ossipee Watershed are at 700 feet elevation or greater, and nearly all the land within this topographic contour consists of steep slopes. For regulatory purposes, this suggests that a Steep Slope/Critical Elevation District could most usefully be defined in the Ossipee Watershed region by the 700-foot contour line.

Zoning or Planning Board regulations of all six towns of the Ossipee watershed recognize in principle that steep slopes pose special concerns for health (septic systems), environment and in some cases for preservation of scenic views. Protections currently in place vary widely, however. Regulations in Effingham and Sandwich are most comprehensive, addressing steep-slope timbering as well as development. But no regulations currently in place specifically address the preservation of scenic views, except in the limited context of cell-phone towers:

**Effingham:** Zoning Ordinance contains a section on Steep Slope and Critical Elevations, regulating development on slopes greater than 15% and/or at elevations greater than 1,300 feet. Steep Slope Permits and observance of Best Management Practices in construction and timbering are required in such areas. Timber harvesting is limited to 50% of basal area over a 10-year period on slopes greater than 35%. Subdivision Regulations allow the Planning Board to restrict subdivision of land with “excessive” slope, although this term is not defined.

**Freedom:** Subdivision regulations allow the Planning Board to prohibit subdivision of land found to be unsuitable for development by reason of “excessive” slope, but do not define the term. Land in excess of 25% slope may not be used in determination of lot size requirements. Parcels with slopes between 15-25% require minimum lot sizes of 1.1 to 1.9 acres, or may be prohibited altogether, depending on soil type.

**Ossipee:** The Zoning Ordinance requires larger than the standard minimum lot size of one acre on steep slopes, depending on soil types (1.2 to 2.5 acres on slopes of 8-15% and 4 acres on slopes of 15-25%), with no construction permitted on slopes of 15% or greater on certain soil types. Construction is permitted on slopes steeper than 25% with suitable soils, providing that state waste-disposal standards are met.

**Madison:** Subdivision regulations allow the Planning Board to withhold approval for development of “unsuitable” slopes, but do not define the term. Slopes greater than 33% are excluded from minimum lot size determination.

**Sandwich:** The Zoning Ordinance includes a Steep Slope Regulation applicable to gradients of 15% or more, requiring Steep Slope permits from the Planning Board, which is empowered to require environmental impact studies. The Board may impose deed restrictions requiring annual maintenance of altered steep-slope areas. A 6-acre minimum buildable area is required for single-family dwellings on slopes greater than 15% and approximately 10 acres for multi-family dwellings. The Ordinance excludes slopes greater than 25% from determination of buildable lot size and prohibits “waste-generating” dwellings on such slopes. Timbering and agriculture in steep slope areas are required to adhere to “optimal” management practices as defined by the Carroll County Forester or Conservation Service. A protected Skyline District is defined in the town’s steep slope map for purposes of telecommunications towers.

**Tamworth:** Subdivision regulations provide a formula for minimum lot size that relates dwelling size to soil type and slopes up to 25% percent. Residential construction is excluded on certain soil types on steep slopes.

### **III. Current and Potential threats**

Construction on steep slopes or high elevations presents a number of issues – not only the preservation of views that are central to the tourism economy and the rural quality of the land, but also challenges to safety, public health and the preservation of critical wildlife habitat. The New Hampshire Office of Energy and Planning counts some two dozen towns in the state that have begun to address these issues through steep-slope and high-elevation protection ordinances and regulations that seek to reconcile property rights with broad community interests.

Preservation of views – the aesthetic qualities of hillsides and ridgelines – are often the main consideration that local governments cite for adopting Steep Slope/ High Elevation regulations, the regulations themselves state their purpose in terms of more easily measurable environmental standards related to effects of development on water quality, erosion control and the difficulties of providing utilities and emergency services in steep-slope areas

“New Hampshire residents and visitors place great value on the state’s natural resources, “ the NH Department of Environmental Resources noted in a 2006 review of steep-slope regulation. “Protecting hillsides and steep slopes from development helps to preserve those unique environmental qualities that people value.”

In New Hampshire, the regulation of development on steep slopes is authorized under RSA 674:14, the zoning Grant of Power, and RSA 674:21, Innovative Land Use Controls. Existing regulations are found mainly in town ordinances, but also in subdivision/site plan review regulations administered by Planning Boards.



While residential construction is the main concern, the citing of telecommunications towers is a recurrent community issue. However, timbering – especially clear-cutting – in steep slope areas can have a particularly dramatic impact on vulnerable soils and the streams that drain them, on wildlife habitat, and on scenic views that define a town’s rural character.

#### **IV. Recommendations**

A survey of steep slope regulations prepared by the Lakes Region Planning Commission in December 2005 found that hillside regulations adopted since the 1980s emphasize design guidelines to reduce the visual effects of grading and to make hillside structures blend into their surroundings and appear smaller. These design guidelines are often coupled with regulations that prohibit most construction on slopes exceeding a particular grade, usually 25%. These regulations can take a stand-alone form or be incorporated into zoning or subdivision regulations, often through an overlay district in rural zoned areas.

#### **Key Topics:**

It is important to collect as much data as possible to form the basis of an ordinance. In a 1996 publication, Robert Olshansky, an expert on hillside development outlined ten topics that should be considered prior to implementing a regulation. These ten topics, which are outlined below, can be used as a framework to build a solid justification for regulating steep slopes, hillsides and ridgelines:

- **Topography:** Steep slopes are typically defined as 15% or greater (meaning that elevation rises 15 feet or more over a distance of 100 feet.) Topographic maps can be used to define a steep slope overlay district by grade or by all areas above a particular elevation.
- **Slope Stability and Soils:** Soil characteristics are closely linked to slope grade. Before development is permitted, it is important to know how grading can affect slope stability. On steep slopes, any change in the equilibrium, whether it is caused by natural phenomena such as heavy rains or earthquakes or human activities, can cause erosion or landslides.
- **Drainage and Erosion:** Disturbing soils on steep hillsides can dramatically affect erosion rates and stream sedimentation, leading to increased runoff into lakes, ponds and wetlands. Changing drainage patterns can compromise water quality. All highly erodible soils should be identified.
- **Infrastructure:** Septic systems on steep hillsides are especially prone to failure, both because of the slopes and because the soils tend to be shallow and poorly drained, posing potential downslope and downstream health hazards. In New Hampshire, no septic system may be placed on a slope greater than 33%, however individual municipalities may implement stricter regulations, or develop inspection/maintenance programs. Roads, power and telephone lines are more costly to lay on steep hillsides, and maintenance costs are higher.
- **Access:** Roads and driveways on steep hillsides require more curves than in flatter terrain, making them longer and resulting in increased erosion and overall impact on the environment. The New Hampshire Department of Transportation recommends that driveways for commercial activities do not exceed an 8% grade, and that driveways to residences not exceed 15%. Towns may set a lower threshold if they choose. Access for fire and other emergency vehicles in steep, high-elevation areas is more difficult and potentially dangerous, as is snowplowing.

- **Wildlife Habitat and Vegetation Communities:** Increasing development in flatter lands tends to drive wildlife to seek refuge at higher elevations, even if this is not their natural habitat. Development of hillsides may further fragment high-quality habitat and interrupt transit corridors in hillside retreat areas, magnifying the impact on wildlife diversity, especially of large mammal species. Special attention should be paid to rare and endangered plant and animal species
- **Aesthetics:** Preventing or minimizing the visual impact of hillside and ridgeline development is the reason communities most often cite for steep slope/high-elevation regulations. However, view quality is not easy to define. In general, this requires identifying in photographs particular “Viewscapes” or “Viewsheds” to be protected and any peaks or hillsides of special symbolic value or natural beauty to the community, and laying out sight-lines from village areas and main public roads on a topographic map to define boundaries of the viewshed to be preserved.
- **Fire Hazard:** Steep slope fires do occur in the White Mountain region. Development of steep hillsides brings increased potential for fires and needs to take into account the ability of communities to respond and manage brush, forest and structural fires. Since it is more difficult to control fires which are more likely to be fanned by high winds on hillsides than on flat areas, it is important to evaluate the frequency and causes of hillside wildfires, identify fuel reduction methods, and identify architectural and landscaping factors in fire safety.
- **Recreational Value:** Hiking, hunting, climbing and wildlife observation are often of highest value on mountain or hillside slopes. Establishing and preserving trails and access for low-impact recreational use, through conservation easements, may be critical to preserving community values and a tourist economy. Locating possible access points to existing and potential recreational opportunities is also important.
- **Open Space:** Preserving open space on steep slopes and hillsides is a key part of regulating development. Mechanisms include creating greenways, protected wildlife habitat and conservation lands.

## V. **Helpful Hints / Links / Resources**

1. Innovative Land Use Planning Techniques: A Handbook for Sustainable Development, expected publication date January 2007, prepared as part of the Regional Environmental Planning Program by the NH Department of Environmental Services, the NH Association of Regional Planning Commissions, the NH Office of Energy and Planning, and the NH Local Government Center.
2. New Hampshire Office of Energy and Planning, Steep Slope and Ridgeline Protection: <http://www.nh.gov/oep/programs/MRPA/conferences/documents/IIA-Fall06-ILU-SteepSlopes.pdf>

## VI. References:

1. "Regulating Development on Steep Slopes, Hillside, and Ridgelines," Lakes Region Planning Commission, Meredith NH, December 2005. Includes summaries of such regulations in 16 New Hampshire towns.
2. "Best Management Practices for Hillside/Ridgeline Development," Thomas Kokx Associates, 165 Belknap Mtn. Road, Gilford NH 03249; prepared for the Town of Meredith NH, February 2001.
3. "Town of Meredith Visual Resource Inventory and Assessment," Thomas Kokx Associates, March 8, 1999.
4. "Planning for Hillside Development: Planning Advisory Service Report No. 466, American Planning Association," Robert Olshansky, Chicago, 1996.
5. Bureau of Land Management. Manual H-8410-1 - Visual Resource Inventory. Washington, DC: U.S. Department of the Interior, Bureau of Land Management <http://www.blm.gov/nstc/VRM/8410.html#Anchor-49575>. This manual provides a process for inventorying and prioritizing important visual resources.

**VII. Sample Ordinance:** The following sample ordinance is adapted from a model developed in 2006 by the New Hampshire Department of Environmental Services:

### Model Language, Illustrations, and Guidance for Implementation

This model ordinance contains two sections: Steep Slopes Protection and a Visual Resource Protection District. Steep Slopes Conservation should be adopted as a component of the zoning ordinance that applies in all districts. The Visual Resource Protection District is an overlay district where the boundaries are determined through a visual resource inventory process. Suggested enhancements of this draft are noted in *boldface italic text*.

### Statutory Authorization

- A. RSA Title LXIV, Chapters 674:16, Grant of Power
- B. 674:21, Innovative Land Use Controls
- C. 674:21 (j), Environmental Characteristics Zoning
- D. 673:16, II; 674:4, I(g); and 674:44, V collectively authorize Planning Boards to collect fees from applicants to cover the costs of hiring outside experts to review subdivision applications and site plans.

### A. Steep Slopes

Title: Steep Slopes Protection

#### Section 1: Purpose

The purpose of this ordinance is to reduce damage to streams and lakes from the consequences of excessive and improper construction, erosion, stormwater runoff, or effluent from improperly sited sewage disposal systems, and to preserve the natural topography, drainage patterns, vegetative cover, scenic views, wildlife habitats, and to protect unique natural areas.

## Section 2: Delineation

This ordinance shall apply to all areas with a slope greater than 15%, as shown on the town's steep slopes map, and where the site disturbance is greater than one acre.

## Section 3: Definitions

- Erosion: The wearing away of the ground surface as a result of the movement of wind, water, ice, and/or land disturbance activities.
- Sedimentation: The process by which sediment resulting from accelerated erosion has been or is being transported off the site of the land-disturbing activity or into a lake or natural watercourse or wetland.
- Passive recreation: Those recreational pursuits which can be carried out with little alteration or disruption to the area in which they are performed. Such uses include but are not limited to hiking, picnicking, birdwatching, and bicycle paths/trails.
- Building envelope: An area or "footprint" designated as a location within which a dwelling unit is to be placed on a lot in compliance with the building setback and spacing requirements established by the zoning regulations.
- Slope: The degree of deviation of a surface from the horizontal, usually expressed in percent or degrees; rise over run.
- Steep slope: A slope of 15% or greater.
- Extreme steep slope: A slope greater than 25%.
- Vegetative cover: Grasses, shrubs, trees, and other vegetation which hold and stabilize soils.

## Section 4: Application Requirements

- A. Uses that will cause more than one acre of site disturbance must show the building envelope in 2-foot contours.
- B. An engineering plan will be prepared by a Professional Engineer that shows specific methods that will be used to control soil erosion and sedimentation, soil loss, and excessive stormwater runoff, both during and after construction.
- C. A hydrology, drainage, and flooding analysis will be included that shows the effect of the proposed development on water bodies and/or wetlands in the vicinity of the project.
- D. A grading plan for the construction site and all access routes will be prepared.

NOTE: If a significant portion of the lot will never be developed, the Planning Board may choose to permit the undeveloped area to be shown in 20-foot contours.

## Section 5: Performance Standards

All uses permitted in the underlying district will be a conditional use in the Steep Slope Conservation District and must meet the following conditions for approval:

- A. The grading cut and fill should not exceed a 2:1 ratio.

- B. Existing natural and topographic features, including the vegetative cover, will be preserved to the greatest extent possible. In the event that extensive amounts of vegetation are removed, the site shall be replanted with indigenous vegetation and shall replicate the original vegetation as much as possible.
- C. No section of any driveway may exceed a 10% slope for residential subdivisions or 8% slope for nonresidential site plans.
- D. No structure shall be built on an extremely steep slope (greater than 25%).
- E. *Minimum Lot Size of a parcel averaging more than 15% grade shall be four (4) acres.***

Section 6: Administration of conditional use permits

In addition to meeting the conditions set forth in this section, Conditional Use Permits shall be granted in accordance with the following pertinent procedures:

- A. A Conditional Use Permit shall be granted by the Planning Board upon a finding that the proposed use is consistent with the intent of the Ordinance and following receipt of a review and recommendation of the Conservation Commission and any other professional expertise deemed necessary by the Board.
- B. The applicant must demonstrate that no alternatives are available for the productive use of areas outside of the sloped district, that no alternatives exist to the proposal under consideration, and that all measures have been taken to minimize the impact that construction activities will have upon the District.

Section 7: Costs

All costs pertaining to the consideration of an application, including consultants fees, on-site inspections, environmental impact studies, notification of interested persons, and other costs shall be borne by the applicant and paid prior to the Planning Board’s final action.

**B. Ridgelines/Hillsides/Viewshed Protection**

Title: Visual Resource Protection District

Section 1: Purpose

Ridgeline and hillside development is more visible than level terrain development. Therefore, ridgeline and hillside development regulations are designed to make ridgeline development as visually pleasing as possible.

Panoramic views from hillside roads and public places are as important to the character and amenities of the community as views facing the ridgeline and hillside development. The provision for view opportunities for all residents and visitors plays an important role in creating a positive character for ridgeline and hillside communities.

Section 2: Delineation:

The Visual Resource Protection District is an overlay district that will be defined by a visual resource

NOTE: Each community will have unique visual resources. It is the responsibility of the community implementing this ordinance to complete and document a comprehensive visual resource inventory. A manual detailing the Bureau of Land Management’s Visual Resource Management Strategy is available online:  
<http://www.blm.gov/nstc/VRM/8410.html#Anchor-49575>

inventory dated\_\_\_\_\_. The results of the visual resource strategy will be shown on the Visual Resource Map, which is hereby incorporated into this ordinance.

### Section 3: Definitions

**Design Guidelines:** A set of guidelines defining parameters to be followed in a site or building design or development

**Passive recreation:** Those recreational pursuits which can be carried out with little alteration or disruption to the area in which they are performed. Such uses include but are not limited to hiking, picnicking, bird watching, and bicycle paths/trails.

**Building envelope:** An area or “footprint” designated as a location within which a dwelling unit is to be placed on a lot in compliance with the building setback and spacing requirements established by the zoning regulations.

**View:** A range of sight including pleasing vistas or prospects or scenes. Views include but are not limited to the sight of geologic features, bays, fields, rivers, mountains, lakes, skylines, bridges, and distant cities and towns.

**Viewshed:** The area within view from a defined observation point.

**Visual Impact:** A modification or change that could be incompatible with the scale, form, texture or color of the existing natural or man-made landscapes.

**Visual Resource Map:** The map depicting the visually sensitive areas, as determined by the visual resource inventory.

**Visual Resource Inventory:** A system for minimizing the visual impacts of surface-disturbing activities and maintaining scenic values. The inventory consists of a scenic quality evaluation, sensitivity level analysis, and a delineation of distance zones.

### Section 4: Application Requirements

- A. Uses that will cause more than one acre of site disturbance must show the buildable area in 2-foot contours.
- B. An engineering plan will be prepared by a Professional Engineer that shows specific methods that will be used to control soil erosion and sedimentation, soil loss, and excessive stormwater runoff, both during and after construction.
- C. A hydrology, drainage, and flooding analysis will be included that shows the effect of the proposed development on water bodies and/or wetlands in the vicinity of the project.
- D. A grading plan for the construction site and all access routes will be prepared.

NOTE: If a significant portion of the lot will never be developed, the Planning Board may choose to permit the undeveloped area to be shown in 20-foot

## Section 5: Administration of Conditional Use Permits

Conditional Use Permits shall include the findings of an architectural review in accordance with the following pertinent procedures:

- A. A Conditional Use Permit shall be granted by the Planning Board upon a finding that the proposed use is consistent with the intent of the Ordinance and following receipt of a review and recommendation of the Conservation Commission and any other professional expertise deemed necessary by the Board, such as a licensed architect.
- B. The applicant must demonstrate that no alternatives are available for the productive use of areas outside of the District, that no alternatives exist to the proposal under consideration, and that all measures have been taken to minimize the impact that construction activities will have upon the District.

## Section 6: Design Guidelines

In order to reduce the visual impact of development in the Visual Resource Protection District, all proposed structures shall meet the following design guidelines:

- A. Building Envelope: The building envelope permitted in this district is a rectangle with an up-slope boundary 40 feet or less from the building, side boundaries 40 feet or less from each side of the building, and a down-slope boundary 25 feet or less from the building. Accessory structures shall be built within the building envelope. Building envelopes shall be at least 30 feet from property lines.
- B. Clearing for views: In order to develop a view, trees may be removed beyond the building envelope for a width of clear cutting not to exceed 25 feet and extending outward therefrom at an angle of 45 degrees or less on both sides. The 25 foot opening may be at any point along the down-slope boundary. ***In general, tree- and brush-clearing shall be minimized to as to create a gradual transition to open areas.***
- C. Natural/neutral colors will be used ***so as to blend with the surrounding landscape to minimize visibility from a distance.***
- D. Reflective glass will be minimized.
- E. Only low level, indirect lighting shall be used. Spot lights and floodlights are prohibited. ***[Alternative: Night-time lighting impact will be minimized by use of full-shielded "Dark-Sky" compliant lighting fixtures mounted less than 10 feet above ground; low posts and bollards are preferred. Spot and floodlights are prohibited.]***
- F. No portion of any structure shall extend above the elevation of the ridgeline ***or above the surrounding tree crown level.***
- G. Structures shall use natural landforms and existing vegetation to screen them from view from public roads and waterways to the extent practicable; ***designs should fit the landscape, rather than altering landscape to fit design.***
- H. Cuts and fills are minimized, and where practical, driveways are screened from public view.
- I. Building sites and roadways shall be located to preserve trees and tree stands.
- J. ***Where practical, utilities should be underground.***
- K. ***An undisturbed buffer of at least 100 feet shall be preserved on both banks of any stream, including intermittent seasonal streams.***

## Section 7: Agriculture, Silviculture and Logging (added):

Agriculture and Silviculture and Logging may be practiced may be practiced on designated steep slopes if conducted consistent with optimum soil conservation and forest management practices, as determined by the Carroll County Conservation Service, the County Forester, or other interested State

or Federal agencies. No clear-cutting of timber on an area greater than one acre shall be permitted unless the Carroll County Forester specifically certifies in writing that such cutting is consistent with optimum forest management practices, such as the removal of windfall or diseased timber.

### **Section 8: Costs [Section 7 in original NHDES draft]**

All costs pertaining to the consideration of an application, including consultants fees, on-site inspections, environmental impact studies, notification of interested persons, and other costs shall be borne by the applicant and paid prior to the Planning Board's final action.

## **Model Regulations**

### **A. Steep Slopes:**

Existing New Hampshire ordinances and regulations applicable to steep slopes and high elevations generally include the following provisions:

- Steep slopes are commonly defined as those greater than 15%, or for septic design purposes, greater than 12%. On slopes greater than 25%, no waste-generating construction is permitted. Some towns permit only single family residences on slopes between 15% and 25%.
- An overlay district in rural zoned areas – a Steep Slope Conservation District overlay map -- may be defined as all terrain above a specific elevation, within which design guidelines apply to all land, regardless of slope, with construction prohibited on hillsides greater than 25% grade and clear-cutting of timber prohibited except as good forestry practice may require (for instance, removing windfall or diseased stands of trees.)
- Environmental impact in steep or high elevation areas can be reduced by requiring larger minimum lot sizes, such as 5 to 6 acres, than on flatter land, so as to reduce the density of development.
- Special design standards, or Best Management Practices, may be defined for hillsides between 15% and 25% or in high-elevation areas. These standards minimize undue impact on fragile environments and may include:
  - No construction on ridgelines or prominent knolls visible at a range of 0.5 miles or more from public roads;
  - Roads and driveways should be as narrow as possible and follow contours to minimize need for blasting or grading;
  - Utilities placed underground;
  - Rooflines below tree-crown level;
  - Minimize tree removal for view purposes from the built residence; create gradual transitions into open areas, leaving clumps of vegetation rather than individual trees;



- Site plans preserve natural features, landforms and vegetation to the fullest extent possible to avoid visible scarring of the landscape; designs fit the landscape, rather than the landscape being altered to fit design.
- Use of low retaining walls on cut slopes reduces need for cut-and-fill operations visible from a distance;
- Exterior materials and coloring of structures should blend with the surrounding landscape;
- In subdivisions, set aside reserve areas where existing vegetation is preserved; naturally vegetated setbacks and buffers between parcels should minimize visibility from a distance.
- Varied and interrupted rooflines and wall planes reduce the visual scale of buildings.
- Nighttime lighting impacts minimized by fully shielded “dark sky” lights, set on poles less than 10 feet tall; lighted posts or bollards are preferred, and spot lighting is prohibited.

## **B. Viewshed Protection:**

Effective protection of hillside views from public roads, villages and water bodies begins with a detailed photographic inventory of views that should be subject to protection, with full opportunity for community input.

Once key views are identified, sightlines defining the boundaries of the views may be drawn on a topographic map to create a “Visual Resource Protection District” (see the model ordinance below.) The expertise of a landscape architect may be required. To reduce the number of views to a practical number, it may be necessary to prioritize them, again in consultation with the community.

In the town of Meredith, for example, a 1999 viewshed protection project identified and mapped 92 views in potential need of preservation. The town then categorized and prioritized its viewsheds, to single out those widely regarded in the community as “Highly Significant” (51 in all) as opposed to “Important”, “Focal”, “Point of Interest” and “Potential”. These 51 views generally included combinations of Lake Winnepesaukee, mountains and attractive elements of the village. Others included cultural or historic features or sweeping views of mountains as seen across open fields.

Meredith has not enacted regulations specifically aimed at preserving these views, which in most cases encompass multiple private landholdings. Instead, the town encourages application of Best Management Practices to construction or other landscape alteration within the identified viewscapes.

**Ossipee Watershed Coalition**  
**Natural Resource Planning Guide**  
**Chapter V - I - Air Quality**

**I. Introduction: Why this Resource is Important**

Clear, clean air is critical to the rural attractiveness of the Ossipee Watershed's tourist-based economy and to the health of all of its inhabitants. Too frequently our view is impeded by human-caused haze. The CAMNET website ([www.hazecam.net](http://www.hazecam.net)) points out that our "typical visual range in the eastern U.S. is 15 to 30 miles, or about one-third of what it would be without manmade air pollution". This irritating and in some cases debilitating interference is especially noticeable here in vacation country that features scenic vistas.

The sources and impacts of some air quality issues are local in scale, while others are regional or even global. Local vigilance is needed to identify the nature and extent of threats to air quality. In some cases, local actions can help to remedy or at least reduce air quality problems. In other cases, solutions require much wider scale attention from broader up-wind sources.

**II. Description of the Resource**

There are excellent sources of information regarding New England's climate and weather (e.g., AIRMAP, a joint program of NOAA and UNH at: <http://airmap.unh.edu/background/ClimatePrimer.html>).

They cite the confluence of weather-generating factors that result from northern New England's location: on the cold-current coast, its latitude, its mountainous topography, and its position relative to hemispheric air mass movements. This brings our notoriously changeable and sometimes severe weather patterns.

Generally speaking, air quality in Carroll County is good, in most cases falling well below national standards. Table V-I.1-1 shows levels for the six major air pollutants observed at sites at or nearest to Carroll County. However, ground-level ozone and small particulates are problematic too frequently leading to conditions considered hazardous for sensitive members of the public.

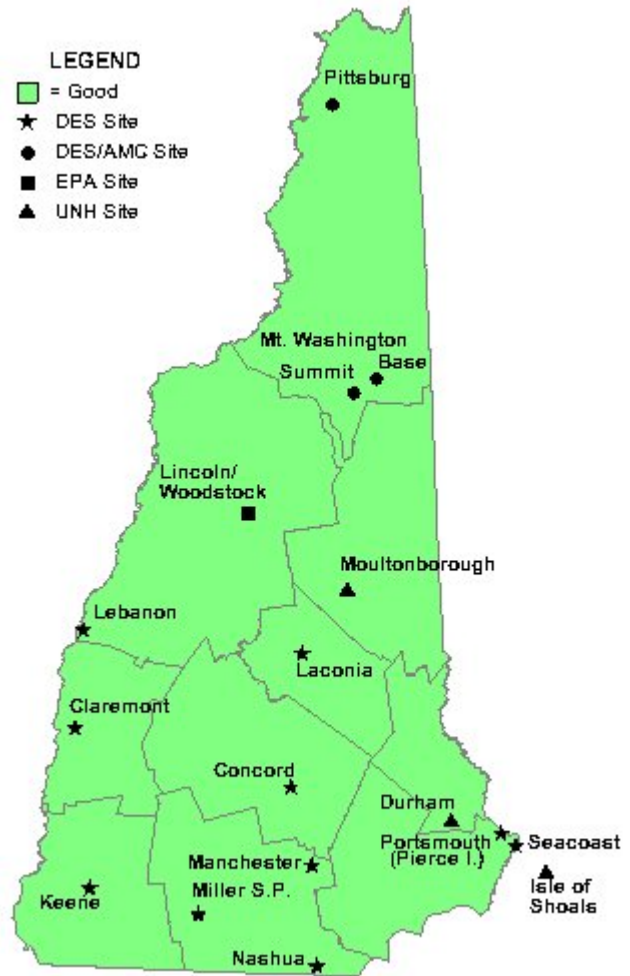

Chapter V-I, Figure 1 Map of Current Air Quality Monitoring Stations

New England has also suffered from increased acidity in precipitation – the Acid Deposition issue. Lower pH (higher acidity) has been shown to negatively impact fish populations, the level of metals in water sources, nutrient levels in soils, and even the integrity of some building materials. It results primarily from the emission of sulfur and nitrogen oxides from fossil fuel combustion. Cumulative buildup of these emissions, swept to the Northeast from power generation and industrial productivity in the mid-West, coupled with soils that lack the capacity to adequately buffer increased acidity, have left New England particularly vulnerable. In recent years, controls on sulfur dioxide emissions have dramatically reduced this source of acidity. However, progress on reducing nitrogen oxides, largely from internal combustion engine emissions, has been far less effective. The Acid Deposition issue in our area has declined but is not eliminated.

Chapter V-I, Table 1 Trends in Air Pollution Data for New Hampshire. Locations in or closest to Carroll County have been selected. Arrows reflect increasing or decreasing trends. Data source: <http://www.epa.gov/airtrends/where.html>.

<b>Pollutant</b>	<b>Time Period</b>	<b>Location</b>	<b>Observed Level</b>	<b>National Standard</b>	<b>Averaging Method</b>
CO	1990-2006	Nashua	↓ 9-2.5 ppm	9 ppm	Annual 2 <sup>nd</sup> max 8-hr average
Ground-level Ozone	1996-2002	Carroll Cty	↑ 0.06-0.07 ppm	Ca 0.08 ppm	Annual 4 <sup>th</sup> max 8-hr average
Pb (lead)	1990-1993	Merrimack Cty	ca 0.0 µg/m <sup>3</sup>	1.5 µg/m <sup>3</sup>	Quarterly average
NO <sub>2</sub>	1998-2002	Rockingham Cty	<0.01 ppm	0.053ppm	Annual arithmetic average
Particulates	2002-2006	Belknap Cty	7-10 µg/m <sup>3</sup>	15 µg/m <sup>3</sup>	Seasonally weighted annual average
SO <sub>2</sub>	1994-1998	Coos Cty	<0.005 ppm	0.03 ppm	Annual arithmetic average

### III. Current and potential threats to Air Quality in the region

Ozone and Particulate Matter (information slightly modified from NHDES website)

Ozone is formed as a result of chemical reactions between oxygen, volatile organic compounds (VOCs), and oxides of nitrogen (NO<sub>x</sub>). Its sources include vehicles, factories, landfills, industrial solvents, and miscellaneous small sources such as gas stations, lawn equipment, etc. Excessive levels of ozone irritate the respiratory tract, produce impaired lung function such as inability to take a deep breath, cause throat irritation, chest pain, cough, lung inflammation and possibly susceptibility to lung infection, aggravate existing respiratory conditions like asthma in certain individuals, and may reduce yield of agricultural crops and injure forest and other vegetation.

Ground-level ozone, more commonly called summertime smog, is measured in parts per billion (ppb). The federal health based standard for an 8-hour concentration is set at 80 ppb so levels above this standard are considered to be unhealthy. Since ozone is a summertime pollutant, wintertime monitoring is limited and no wintertime forecast in NH is provided. Full monitoring, reporting, and forecasting for ozone occurs from April through September. During this “Ozone Season” information is provided to the media and the public regarding when air quality exceeds standards, along with associated health risks and suggested precautions.

Particulates are derived from smoke, dust, fly ash, and condensing vapors. They result from burning of wood, diesel and other fuels, industrial plants, and from dust generated from agriculture (plowing, burning off fields) and unpaved roads and construction. The particulate contribution made by the release of volatile organic carbon products from trees is minor in our region. Excessive particulates cause nose and throat irritation, lung damage, bronchitis, and possibly premature death. Children, the elderly, and people suffering from heart or lung disease are especially at risk. They also damage paint, soil clothing and furniture, and reduce visibility.

Particulate pollution (small particles) consists of both solid and liquid particles that are less than 2.5 microns in diameter (a micron is a millionth of a meter). Particle concentrations are measured in micrograms per cubic meter ( $\mu\text{g}/\text{m}^3$ ) and levels above  $35 \mu\text{g}/\text{m}^3$  over 24 hours are considered to be unhealthy. Monitoring and reporting of small particles occur year-round. During the summer months, small particle pollution (also known as  $\text{PM}_{2.5}$ ) is reported in conjunction with ozone levels. The New Hampshire Department of Environmental Services (DES) publishes information regarding when particulate pollution exceeds standards, along with associated health risks and suggested precautions.

### Monitoring Data

Air quality characteristics are monitored at several sites throughout the state (see Fig. V-I.1-1). The DES operates the majority of these. The University of New Hampshire operates additional sites as part of their AIRMAP program, the Appalachian Mountain Club (AMC) maintains three monitors in northern New Hampshire, and the Hubbard Brook Research Foundation (HBRF) maintains one station in cooperation with the EPA. (The data from HBRF may be downloaded from CASTNET).

To investigate real-time local air quality, you can visit the DES website <http://www2.des.state.nh.us/airdata/> where you will find a table such as the one shown in Table V-I.1- 2 for March 22, 2007. It shows real-time air quality data collected at New Hampshire's air monitoring sites for **ground-level ozone** and **particle pollution**.

In general, reporting, and forecasting for ozone occurs from April through September; monitoring and reporting of small particles occurs year-round. The information in the DES on-line table is updated every hour and includes wind speed, wind direction, and outside temperatures (if data are available). Data shown in the table are linked to the state map; both the table and map are color coded according to EPA's Air Quality Index, which relates air pollutant concentrations to health effects and recommended actions. Placing your cursor over the table cell displays the health message; *Clicking* on the table cell displays a graph of pollutant levels over the previous 48 hours.

DES also has a toll free Air Quality Hotline that is updated every day. Call 1-800-935-SMOG to track your daily air quality.

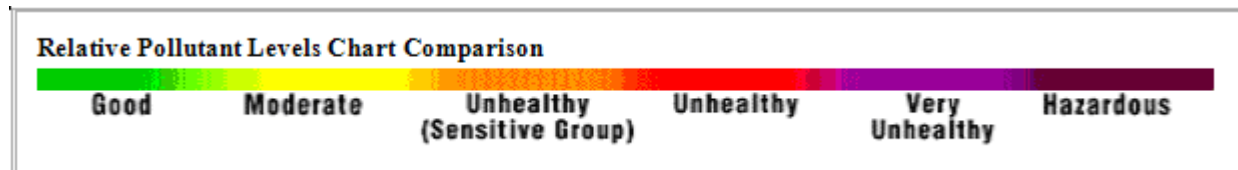

### Real-time Monitoring Station Data

Placing your cursor over the table cell displays the health message; *Clicking* on the table cell displays a graph of pollutant levels over the previous 48 hours.

Site Location	8-hour Ozone (ppb)	24-hour Small Particles (ug/m <sup>3</sup> )	Wind Speed and Direction	Temp.
Claremont – DES	Seasonal			
Concord – DES	Seasonal		SW @ 11 mph	42° F
Durham – UNH	39		SSW @ 6 mph	44° F
Isle of Shoals (Appledore Island) – UNH	Seasonal		SSW @ 22 mph	38° F
Keene – DES	Seasonal			
Laconia – DES	Seasonal			
Lebanon Airport – DES	33	4	SW @ 8 mph	37° F
Lincoln/Woodstock (Hubbard Brook Experimental Forest) - EPA	24			40° F
Manchester – DES	29	7	SSW @ 3 mph	43° F
Mount Washington Base - DES/AMC	Seasonal	1		
Nashua – DES	44		S @ 7 mph	49° F
Pittsburg – DES/AMC	Seasonal			
Portsmouth (Pierce Island) – DES	36	3	SW @ 8 mph	
Seacoast (Odiorne State Park, Rye) – DES	Seasonal			
High Elevation Site Location	8-hour Ozone (ppb)	24-hour Small Particles (ug/m <sup>3</sup> )	Wind Speed and Direction	Temp.
Miller State Park (Southern Mountains) - DES	40	3	NW @ 17 mph	35° F
Moultonborough (Central Mountains) - UNH	36		WSW @ 6 mph	34° F
Mount Washington Summit (Northern Mountains) - DES/AMC	59			

- NOTES:**
- Ozone values are based on eight-hour running averages; Small Particle values are based on twenty four-hour running averages. If, due to absence of data, a complete-period average cannot be calculated, the average is displayed within square brackets (e.g., [ 31 ])
  - Data in the table are based on real-time hourly averages for the time period ending: 9 am 3/22/2007 EST. All real-time values are unofficial pending full quality assurance/quality control evaluation.
  - Wind Speed, Wind Direction, and Temperature values are based on the latest one-hour average.
  - N/D indicates that the Site is enabled but the latest-period data are temporarily unavailable.
  - N/R indicates that the Site is currently disabled.
  - Grayed-out cells indicate that the parameter is not collected at the Site.
  - Seasonal indicates that Ozone monitoring occurs from April through September at the site.

**Chapter V-I. Table 2** Real-Time Monitoring Station Data for New Hampshire. This example is for March 22, 2007. Access this interactive site at: [DES website http://www2.des.state.nh.us/airdata/](http://www2.des.state.nh.us/airdata/)

For the Ossipee Watershed Area, looking at the Mt Washington, Lincoln/Woodstock and Moultonborough monitoring data would be most appropriate. But bear in mind that there will be differences due to the distance between the Ossipee Area and these particular monitoring locations. Also sites upwind of the Ossipee Area would be important depending on the season and wind direction. Summers tend to offer more southerly winds and “down state” air monitoring stations could provide information as to what may be heading toward the Ossipee Area.

### Some Specific Sources of Particulate and Other Air Pollutants

#### A. Outdoor wood-fired hydronic heaters.

Outdoor wood-fired hydronic heaters (OWHHs, also known as "Outdoor Wood Heaters," "Outdoor Wood Boilers," or "Outdoor Furnaces") are typically located outside the buildings they heat in small, insulated sheds with short smokestacks. They burn wood to heat liquid (water or water-antifreeze) that is piped underground to provide heat and hot water to occupied buildings such as homes, barns and greenhouses. Most OWHHs are sold for use in rural, cold climate areas where wood is readily available; however, OWHHs can be found throughout the United States.

Outdoor wood-fired hydronic heaters can be substantially dirtier and less efficient than most other home heating technologies. With their smoldering fires and short smokestacks (usually no more than six to ten feet tall), OWHHs create heavy smoke and release it close to the ground, where it often lingers and exposes people in the area to nuisance conditions and health risks.

Although these units are designed to burn dry, seasoned wood, some people use them to burn green wood, which generates much more smoke. Others burn household trash or construction debris, which not only release harmful chemicals and pollution, but is against state law.

Outdoor wood-fired hydronic heater emissions are a significant concern in many local areas. Numerous scientific studies report potentially serious adverse health effects from breathing smoke emitted by residential wood combustion. Residential wood smoke contains fine particles, which can affect both the lungs and the heart.

Many local agencies have developed ordinances that will soon regulate outdoor wood-fired hydronic heaters. EPA is working with the Northeast States for Coordinated Air Use Management (NESCAUM) and others to develop a model rule that state and local agencies can use to regulate outdoor wood-fired hydronic heater emissions. EPA also has initiated a voluntary program for manufacturers of OWHHs. To participate in the OWHH program, manufacturers commit their best efforts to develop cleaner models, which are those that meet EPA performance verified levels (emission limits), with the goal of distributing these units starting in April 2007.

In addition, the program will focus on educating new and current OWHH users on the health effects of woodsmoke, [what to look for when purchasing these units](#), and how to properly operate an OWHH.

## **B. Wood Burning**

Wood Burning is prevalent in northern rural areas. Many homes use woodstoves as a primary source of heat while others use woodstoves and fireplaces as supplemental heating sources. Unfortunately smoke from woodstoves can be a significant source of air pollution impacting public health and the environment. The smoke produced from woodstoves and fireplaces contains over 100 different chemical compounds, many of which are harmful and potentially carcinogenic. Smoke from wood stoves is generated primarily by incomplete combustion, which can be caused by a number of different factors related to the wood stove's efficiency. Improving a wood stove's efficiency through design features of the stove and education regarding its operation and maintenance will improve the combustion process and thus reduce the amount of smoke and harmful air pollutants released into the air.

## **C. Residential Trash Burning**

Open burning of residential trash materials is prohibited by law in New Hampshire (as of January 1, 2003). The burning of residential waste materials, such as paper, plastics, household trash and garbage, in a burn barrel or backyard incinerator was once a common practice in New Hampshire. This practice is no longer necessary due to New Hampshire's progress in providing access to facilities and services that recycle and dispose of solid waste. The practice of open burning, and particularly backyard burning of trash, can result in many harmful public health and environmental effects.

## **E. Transportation Management**

The Route 16 corridor is known for its high volume traffic. The Towns in the Ossipee Watershed area can help through local efforts to minimize traffic congestion and thereby helping to minimize impacts to air quality resulting from idling or slow-moving vehicles. Contacting DOT for current information regarding planning activities along the Rt. 16 corridor. Either Ansel Sanborn at 271-7971 or Ram Maddali at 271-6581 would have the information.

## **Global Climate Change**

On a larger scale, scientists have concluded that burning fossil fuels - like oil, coal, and natural gas - to power our cars, homes and businesses is contributing to a rise in global temperatures. This heating of the earth poses a serious threat to our health, safety, economy, and environment.

The good news is that communities all over America, including those in New Hampshire, are responding to the threat of global warming by taking decisive action to reduce heat-trapping emissions, lower energy bills, save taxpayer dollars, and protect our environment. There are several programs that New Hampshire communities can become involved in to set goals and make commitments to reduce carbon dioxide (CO<sub>2</sub>) pollution, also known as reducing our "carbon footprint", in their communities and help combat global warming.

**Clean Air-Cool Planet (<http://www.cleanair-coolplanet.org/>)- A New Hampshire based initiative that is focused on finding and promoting solutions to global warming.**

They partner with companies, campuses, communities and science centers throughout the Northeast to help reduce their carbon emissions; they help partners, their constituents, and other regional opinion leaders and stakeholders understand the impacts of global warming and its best available solutions, through comprehensive outreach efforts celebrating commitment, innovation and success in climate action; they showcase practical climate solutions that demonstrate the economic opportunities and environmental benefits associated with early actions on climate change; they advocate the implementation of effective policy solutions aimed at reducing greenhouse gas emissions at the state and regional levels; they work to build support for the implementation and strengthening of the New England Governors and Eastern Canadian Premiers' regional Climate Change Action Plan.

**Carbon Coalition (<http://www.carboncoalition.org/>)- A New Hampshire based organization that is focused on:** Educating New Hampshire citizens about the local and global impacts of global warming through programs such as the Carbon Coalition Speakers Bureau, and promoting national and local action on climate change solutions through the Town Meeting Campaign and the 2007 Climate Change Conference. Locally, the towns of Effingham, Freedom, Sandwich and Tamworth did participate in the Town Meeting Campaign and voted to support the Coalition's global climate change initiative. The Coalition also facilitates a blog, The Political Climate, on climate change and the NH presidential primary. Most importantly to local towns, they have information on forming local energy committees with the goal of helping towns and their citizens reduce their carbon footprint.

**Cities for Climate Protection Campaign (<http://www.iclei.org/>) – ICLEI: Local Governments for Sustainability** – The Cities for Climate Protection (CCP) Campaign is ICLEI's flagship campaign. Through the CCP, ICLEI works with municipalities to adopt policies and implement measures to achieve quantifiable reductions in local greenhouse gas emissions, improve air quality, and enhance community livability and sustainability. Local governments join the CCP campaign by becoming a member of ICLEI and passing a resolution pledging to reduce greenhouse gas emissions from their local government operations and throughout their communities. ICLEI provides inventory software, annual site visits, and a strong regional, national, and international network of local governments who are committed to a more sustainable future. In New Hampshire, the Cities of Keene, Nashua, and Portsmouth are participating in the CCP campaign.

**COOL CITIES Campaign (<http://coolcities.us/>) – Sierra Club.** Local leaders are joining the Sierra Club's Cool Cities Campaign, marked by signing the U.S. Mayors Climate Protection Agreement to reduce carbon dioxide (CO<sub>2</sub>) pollution in their cities to 7 percent below 1990 levels by 2012. These "Cool Cities" are working to meet this goal with the practical and innovative energy solutions developed by ICLEI to reduce energy waste and pollution, and thereby cut our dependence on oil, benefit public health, and save money.



## IV. Recommendations

1. **Use of Outdoor wood-fired hydronic heaters (OWHH).** The towns in the Ossipee Watershed should help residents understand the potential negative air quality impacts of OWHH and the importance of using only EPA-certified, high efficiency units.

2. **Use of Wood Burning.** The towns in the Ossipee Watershed can educate residents to use only energy efficient stoves, to size and install their stoves appropriately, to burn only dry hard wood for fuel, to burn their stoves efficiently. Encouraging residents to make their homes more energy efficient will also decrease the amount wood they will need to burn during the cold winter months.

3. Because residential trash burning is harmful both to the public and the environment, towns in the Ossipee Watershed Area should educate residents about recycling and composting to minimize their solid waste. Reminding residents that clean, untreated wood can be burned after obtaining a permit is a gentle prompt while reinforcing what cannot be burned. DES has informational brochures that can be handed out to residents in conjunction with up their burn permits. These brochures remind residents of the law prohibiting open burning of trash while providing lists of what can and cannot be burned outside.

4. It is important that local land use planning efforts keep traffic patterns and congestion in mind as decisions are made by planning and zoning boards. Towns can make conscious choices to purchase energy efficient fleet vehicles including hybrids, alternative fuel and high mileage vehicles. Residential education can consist of simple reminders to combine errands for fewer trips, decrease harmful exhaust by turning engines off when parked and keeping vehicles well tuned.

5. While carbon-related climate change issues are especially large scale, significant contributions to solutions can be made by local governments and individuals. Watershed towns may lend their support by participating in programs such as those described above. Towns may encourage citizen involvement in curbing carbon use by

**A. Participating in the State’s Climate Change Challenge**

**([http://www.des.state.nh.us/ard/climatechange/challenge\\_intro.htm](http://www.des.state.nh.us/ard/climatechange/challenge_intro.htm)), or**

**B. Forming an Energy Committee**

**(<http://www.carboncoalition.org/community/EnergyCommitteesResources.php>), or**

**C. Sharing DES’s “Cleaner Air in 10 Easy Steps”:**

- |   |   |
|---|---|
| 1. Walk or ride a bike                      | 7. Use electric or hand-powered lawn care equipment |
| 2. Share a ride                             | 8. Run dishwashers & clothes washers only when full |
| 3. Combine errands for fewer trips          | 9. Use energy-efficient light bulbs & appliances    |
| 4. Keep your car tuned-up & well maintained | 10. Choose environmentally friendly cleaners.       |
| 5. Avoid idling                             |   |
| 6. Keep tires properly inflated             |   |

## V. Helpful Links/Resources on Air Quality Issues

NH DES' Air Quality forecasting [http://www2.des.state.nh.us/airdata/Health Guide and Recommended Actions](http://www2.des.state.nh.us/airdata/Health%20Guide%20and%20Recommended%20Actions)  
[http://www2.des.state.nh.us/airdata/air quality forecast.asp#airguide](http://www2.des.state.nh.us/airdata/air_quality_forecast.asp#airguide)  
NH Air Monitoring Network fact sheet <http://www.des.state.nh.us/factsheets/ard/ard-35.htm>  
Air Quality in NH fact sheet <http://www.des.state.nh.us/factsheets/ard/ard-16.htm>  
Air Quality Trends Nationally <http://www.epa.gov/airtrends/where.html>  
AIRMAP <http://www.airmap.sr.unh.edu/>  
Appalachian Mountain Club <http://www.outdoors.org/>  
Clean Air Status and Trends Network (CASTNET) <http://epa.gov/castnet/>  
Haze Cams in the US, including Mt Washington [www.hazecam.net](http://www.hazecam.net)  
EPA's Air Quality Index <http://airnow.gov/index.cfm?action=aqibroch.index>  
Carbon Coalition (<http://www.carboncoalition.org/>)  
Clean Air- Cool Planet <http://www.cleanair-coolplanet.org/>  
Clean Cities for Climate Protection <http://www.iclei.org>  
COOL CITIES Campaign – Seattle Club [www.seattle.gov/mayor/climate](http://www.seattle.gov/mayor/climate)  
Cool Cities [www.coolcities.us/](http://www.coolcities.us/)  
Outdoor wood-fired hydronic heaters <http://www.epa.gov/woodheaters/>  
NH DES' wood stove and air pollution fact sheet <http://www.des.state.nh.us/factsheets/ard/ard-36.htm>  
Open burning of residential trash fact sheet <http://www.des.state.nh.us/factsheets/ard/ard-33.htm>  
Heavy-Duty Diesel Engines – Trucks & Busses Air Quality Impacts fact sheet  
<http://www.des.state.nh.us/factsheets/ard/ard-34.htm>  
Automobiles & Air Toxics <http://www.des.state.nh.us/factsheets/ard/ard-5.htm>  
Tips to increase fuel efficiency fact sheet <http://www.des.state.nh.us/factsheets/ard/ard-39.htm>  
Transportation/Mobile source pollution fact sheet <http://www.des.state.nh.us/factsheets/ard/ard-6.htm>  
Air Emissions from lawn & Garden Equipment <http://www.des.state.nh.us/factsheets/ard/ard-22.htm>

## VI. Sample Ordinances/Best Management Plans

Since the State (NHDES) and federal government (EPA) regulate air quality emissions, there are no science-based regulations at the local level that are implementable. However, there are Best Management Practices that a town can adopt and undertake education initiatives for its citizens and town employees. These initiatives could include:

1. Formulation of an Energy Committee
2. Education on local sources of air pollution and how to reduce them
3. Initiation of a no-idling campaign
4. Reporting of local air quality concerns to NHDES for assessment

# Ossipee Watershed Coalition Natural Resource Planning Guide Chapter V – J Dark Skies

## I. INTRODUCTION – WHY IS THIS RESOURCE IMPORTANT?

A century ago, the night skies across America were ablaze with stars that inspired awe and wonder in children and adults alike. Constellations, the great arc of the Milky Way, meteor showers and the occasional comet were all easily visible, even from most cities.

For most Americans, a blaze of street-lights, dazzling signs and building illumination have long since washed out all but a handful of the brightest stars, even on the clearest nights. Declining attendance at planetariums in cities across the country underscores the declining visibility, and public awareness, of a great part of the natural world around us – the universe itself. <sup>1</sup>

## II. DESCRIPTION OF RESOURCE

Fortunately for residents of the Lakes Region of New Hampshire and further north, the night sky in most areas outside our town centers remains nearly as dark and dazzling as our grandparents knew it. (Fig.1)

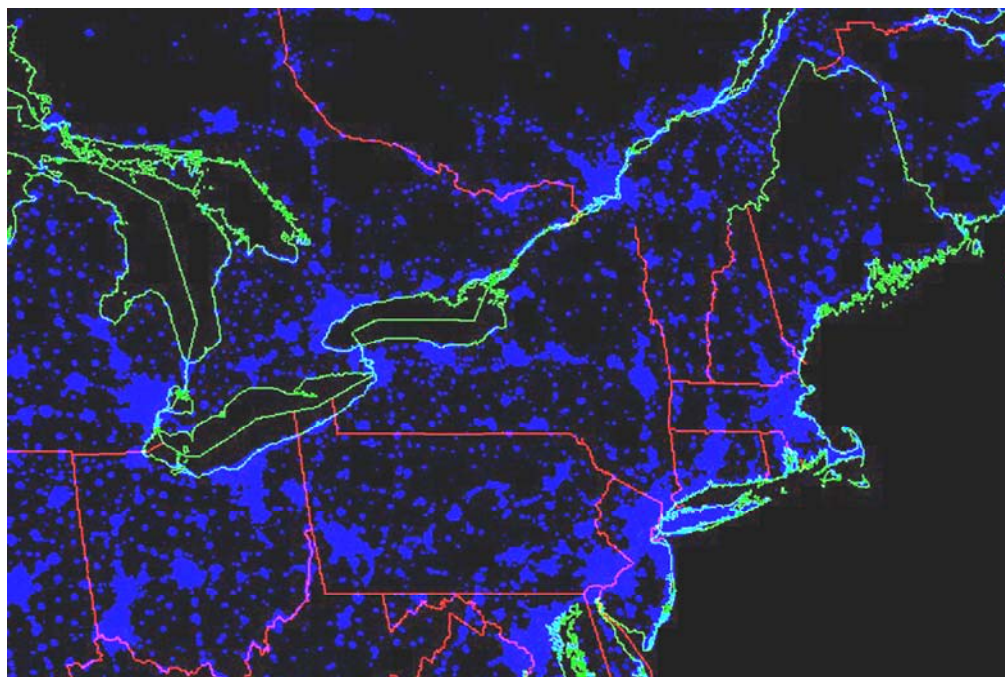

Chapter V-J, Figure 1 Light Pollution in Northeastern United States  
(Derived from NASA imagery)

---

<sup>1</sup> An estimated 10% or less of the U.S. population still enjoys night skies dark enough to see the Milky Way clearly. See, “Reclaim the Night Sky,” Michael Bakich, Astronomy magazine, June 2004.

A pair of binoculars will reveal star clusters, one or two comets a year, glowing nebulae, Jupiter's moons and the great Andromeda galaxy, so distant that the light we see from it today began traveling our way at the dawn of humanity, two and a half million years ago. And the Milky Way is still there (Figure 2).



**Chapter V-J Figure 2 – Comet McNaught & Milky Way – Photo and permission provided by Miloslav Druckmuller**

Yet New Hampshire is the fastest growing state in the Northeast. The U.S. Bureau of Census projects 40% to 60% population growth in Carroll County between 2000 and 2020.<sup>2</sup> Inexorable population growth and the commercial and residential development that comes with it bring the risk of increasing light pollution to this region, unless simple steps are taken to minimize it and preserve one of our scenic natural resources – the night sky.

### **III. CURRENT AND POTENTIAL THREATS**

Preventing light pollution and preserving dark skies is just a matter of awareness. Yet more than a pleasing view of the night sky is at stake. For example, biologists have found that bright artificial lights have harmful effects on a wide spectrum of wildlife, from nocturnal amphibians such as frogs and salamanders to moths and butterflies to migratory birds that fly at night. Researchers estimate that up to 100 million birds are killed annually in North America by the disorienting effects of brightly lit cities, in part when the birds collide with illuminated tall buildings and communications towers topped by bright aircraft warning lights. Amphibians exposed to bright lights have been found to spend less time foraging, and they become more visible to predators.<sup>3</sup>

Of special concern in the Ossipee Watershed is the effect of light pollution on the fragile ecology of Pine Barrens/Pitch-Pine lands, home to a variety of rare and endangered moth and butterfly species and an

---

<sup>2</sup> Data derived from U.S. Bureau of Census, updated to 1998, projecting New Hampshire population growth from 2000-2020, published 1998 by the NH State Office of Planning. Undated map prepared by The Nature Conservancy, New Hampshire.

<sup>3</sup> **Wildlife Action Plan, NH Department of Fish and Game, 2006, Chapter 4, Wildlife Risk Assessment, 4-26 and Appendix A-263.** “Heavily lit urban areas can attract nocturnal migrants (many songbirds, cuckoos, owls, rails) that become disoriented and may die in collisions with structures. Disoriented birds, in turn, may be more susceptible to predation, or may find themselves in inhospitable environments with limited foraging opportunities. Some researchers estimate that upwards of 100 million birds are killed annually in this manner in North America.” See also [www.lightsout.audubon.org](http://www.lightsout.audubon.org)

important habitat for birds. Twenty-nine percent of New Hampshire’s 18,660 acres of Pine Barrens, or 5,474 acres, are found in five towns of the Ossipee Watershed. (Table 1.)<sup>4</sup>

**Chapter V-J Table 1 – NH Pine Barrens/Pitchpine Areas of 500+ Acres**

<b>NH Rank</b>	<b>Town</b>	<b>Acres</b>	<b>% Conserved</b>
1	Concord	2,919	12.6
<b>2</b>	<b>Freedom</b>	<b>1,853</b>	<b>22.2</b>
3	Conway	1,687	20.4
4	Loudon	1,528	3.1
<b>5</b>	<b>Ossipee</b>	<b>1,197</b>	<b>46.6</b>
<b>6</b>	<b>Madison</b>	<b>953</b>	<b>51.9</b>
7	Hopkinton	936	44.2
<b>8</b>	<b>Tamworth</b>	<b>883</b>	<b>28.0</b>
9	Canterbury	700	5.5
<b>10</b>	<b>Effingham</b>	<b>588</b>	<b>48.7</b>
11	Belmont	535	0.4
12	Swanzey	516	18.3
	<b>Total</b>	<b>14,295</b>	
	<b>Averages</b>	<b>1,191.3</b>	<b>25.2</b>

According to the 2006 Wildlife Action Plan of the New Hampshire Fish and Game Department (NHF&G):

“Pine barrens are among the most imperiled natural communities in the world and contribute significantly to the biological diversity of the Northeast. They are dominated by pitch pine and scrub oak interspersed with pockets of grassy openings. Pine barrens plants are in constant flux, maintained by frequent disturbances such as lightning-caused wildfires, which occur naturally and regularly. These communities support a suite of regionally and globally rare species.”<sup>5</sup>

Since the 1980s, wildlife researchers have identified light pollution – excessive, unshielded artificial lighting – as a key threat to the ecological health of pine barrens:

“Light pollution has adverse effects on much of the insect fauna associated with pine barrens. Lepidopterists have long attributed population declines to light pollution, especially in moths. Artificial lighting disturbs flight, navigation, vision, migration, dispersal, oviposition [egg-laying], mating, feeding, and crypsis [protective camouflage] in some moths. It also increases their susceptibility to predation by birds, bats, and spiders. The result may be either changes to behavioral patterns or an alteration in species composition of moths inhabiting illuminated environments.”<sup>6</sup>

<sup>4</sup> **Wildlife Action Plan, Summary Tables** (Excel spreadsheet.)

<sup>5</sup> **Wildlife Action Plan 2006, Habitat Types (Summary: One Granite State, Many Habitat Types.)**

<sup>6</sup> **Wildlife Action Plan 2006, Appendix B-111.**

In addition, field research indicates that the impact of light pollution in sensitive areas such as pine barrens is amplified in small populations that are already threatened by the fragmentation of habitat caused by human development.<sup>7</sup>

Although 34.5% of the Ossipee Watershed's Pine Barrens/Pitchpine land is now under conservation protection, much of the unprotected land – nearly two-thirds of the total – lies in isolated patches close to housing subdivisions or in areas likely to be developed for residential purposes. Some protected areas are bordered by commercial timber-processing facilities that use bright, unregulated sodium-vapor floodlighting at night.

#### **IV. RECOMENDATIONS**

Dark skies are a distinctive feature of the Lakes Region's natural rural environment that merits preservation. This important natural asset is easy to lose as population growth and development accelerate – and easy to save with a few basic rules to prevent light pollution that Planning Boards may incorporate in their Site Plan Review and Subdivision Regulations, or that towns may include in Zoning Ordinances. More than 30 New Hampshire communities have already done so, including Moultonborough and New Hampton in the Lakes Region. At present, however, New Hampshire has no state law designed to minimize light pollution or preserve dark skies.

**The key to preventing or limiting light pollution is to use downward-pointing, shielded or “full cut-off” light fixtures – especially on parking lot and security flood lights, signs and streetlights – that direct all light onto the ground where it is needed, rather than allowing it to radiate laterally or upward into the sky.**

Requiring fully shielded lighting, particularly for commercial purposes, imposes no economic burden as appropriate fixtures cost no more than unshielded fixtures. Yet shielded fixtures also save energy by making more effective use of lighting – putting light where it is needed, on the ground – and at the same time preventing light “trespass,” annoying glare cast on neighboring properties, as well as potentially dangerous glare along highways.

The New Hampshire Office of Energy and Planning (NHOEP) has long encouraged New Hampshire communities to include lighting regulations as part of zoning ordinances or site plan review and subdivision regulations administered by Planning Boards.

In its Technical Bulletin 16 in 2001, the NHOEP noted that careful planning of outdoor lighting and the use of up-to-date fixtures and lamp technology benefits communities by:

- Increasing pedestrian and vehicular safety;
- Preventing unsafe roadway glare and annoying “light trespass” across property boundaries;
- Saving energy;
- Enhancing the rural and historical character of New Hampshire towns;
- Preserving the beauty of dark night-time skies by preventing upward illumination that causes “skyglow” or light-pollution.

NHOEP Technical Bulletin 16 summarizes issues and practical solutions for effective outdoor lighting that provides the benefits listed above, as well as two model regulations.

---

<sup>7</sup> See Note 6.

Although existing local lighting ordinances and planning board regulations vary in detail, they all share one common feature: **Outdoor lighting, including signs, must point downward and be effectively shielded to prevent emission of stray light upward into the sky. Many local regulations (and some states) also ban further use of mercury vapor lamps, which contain toxic mercury.**

Routine exceptions for fully shielded lighting are made for emergency or temporary construction lighting, decorative seasonal lighting and illuminating the American flag.

Public street lighting is governed by the state's two main utilities, Public Service of New Hampshire (PSNH) and the New Hampshire Electric Cooperative (NHEC.) PSNH is encouraging municipalities to participate in its "Smart Start" program to install new energy-saving street lighting at no up-front cost, that municipalities pay for through energy savings. Under this program, PSNH will install fully shielded ("full-cutoff") dark-sky friendly fixtures if asked, at no extra cost.

NHEC is also dark-sky conscious, and has gone a step further by addressing the problem of private floodlights (often attached to utility poles.) According to its website, NHEC "offers only light fixtures that greatly reduce lighting glare and sky glow" that do not illuminate above a horizontal plane drawn through the fixture.

To shield pine barren lands from the adverse effects of artificial lighting, the 2006 Wildlife Action Plan of the New Hampshire State Department of Fish and Game makes the following recommendations:

- 1) Reducing the amount of light pollution in pine barrens habitat will remove external artificial light that can compromise the behavior of nocturnal Lepidoptera [moths and butterflies.
- 2) Nocturnal pine barrens Lepidoptera will be better able to continue their life cycles in natural conditions without light pollution.
- 3) Light reduction would only be implemented in areas where nocturnal Lepidoptera are demonstrated to occur.
- 4) Light reduction would only be implemented during those times of the year when target Lepidoptera are active.
- 5) If new occurrences of nocturnal Lepidoptera are found, light reduction can be implemented in those areas as well.<sup>8</sup>

In addition, NHF&G urges consideration of establishing "light-free reserves" in pine barrens, such as sheltered hollows shielded from lighting. Where habitat is already exposed to artificial lighting, or lighting is essential, low-pressure sodium lamps minimize biological impact. Filters may be placed over mercury vapor lamps to block ultraviolet light to which insects are most sensitive, and metal shields can be added to existing floodlights. NHF&G also urges that landowners be presented with information about the effects of artificial lighting on pine barrens and encouraged to use alternative lighting.<sup>9</sup>

## V. LINKS AND RESOURCES

For information resources on preventing light pollution, consult the International Dark Association at [www.darksky.org](http://www.darksky.org) and the New Hampshire State Office of Energy and Planning, Technical Bulletin 16, 2001.

---

<sup>8</sup> **Wildlife Action Plan, Appendix B-114, Habitats**

<sup>9</sup> **See Note 8**

## VI. MODEL DARK-SKY LIGHTING ORDINANCE

### 1. Statement of Purpose

The intent of this Ordinance is to maintain the rural character of [town], in part by preserving dark night-time skies and minimizing the impact of artificial lighting on nocturnal wildlife. This Ordinance recognizes the importance of lighting for safety and security, but also encourages energy efficiency by directing light where it is needed, onto the ground. This Ordinance also promotes good neighborly relations by preventing glare from outdoor lights from intruding on nearby properties or posing a hazard to pedestrians or drivers.

### 2. Definitions

A. **Direct Light** - Light emitted directly from the lamp, off of the reflector or reflector diffuser, or through the refractor or diffuser lens, of a luminaire.

B. **Fixture** - The assembly that houses the lamp or lamps and can include all or some of the following parts: a housing, a mounting bracket or pole socket, a lamp holder, a ballast, a reflector or mirror, and/or a refractor or lens.

C. **Flood or Spotlight** - Any light fixture or lamp that incorporates a reflector or a refractor to concentrate the light output into a directed beam in a particular direction.

D. **Glare** - Light emitting from a luminaire with intensity great enough to reduce a viewer's ability to see and, in extreme cases, causing momentary blindness.

E. **Height of Luminaire** - The height of a luminaire shall be the vertical distance from the ground directly below the centerline of the luminaire to the lowest direct-light-emitting part of the luminaire.

F. **IESNA** - Illuminating Engineering Society of North America.

G. **Indirect Light** - Direct light that has been reflected or has scattered off of other surfaces.

H. **Lamp** - The component of a Luminaire that produces the actual light.

I. **Light Trespass** - The shining of light produced by a luminaire beyond the boundaries of the property on which it is located.

J. **Lumen** - A unit of luminous flux. One foot candle is one lumen per square foot. For the purposes of this Ordinance, the lumen-output values shall be the INITIAL lumen output rating of a lamp.

K. **Luminaire** - A complete lighting system that includes a lamp or lamps and a fixture.

L. **Outdoor Lighting** - The night-time illumination of an outside area or object by any manmade device located outdoors that produces light by any means.



**M. Temporary Outdoor Lighting** - The specific illumination of an outside area or object by any manmade device located outdoors that produces light by any means for a period of less than 7 days with at least 180 days passing before being used again.

### 3. Outdoor Lighting Design

A. Any Luminaire emitting *more than* 1800 lumens (with 1,700 lumens being the typical output of a 100-watt incandescent bulb) shall be fully shielded so as to produce no light above a horizontal plane through the lowest direct light-emitting part of the luminaire. (Such fixtures usually are labeled “Dark-Sky Certified.”)

B. Any Luminaire with a lamp or lamps rated at a total of *more than* 1800 Lumens, and all flood or spot lights with a lamp or lamps rated at a total of *more than* 900 Lumens, shall be mounted at a height equal to or less than the value  $3 + (D/3)$  where D is the distance in feet to the nearest property boundary. The maximum height of the Luminaire shall not exceed 20 feet.

C. Any Luminaire with a lamp or lamps rated at 1800 Lumens *or less*, and all flood or spot lights with a lamp or lamps rated at 900 Lumens *or less*, may be used without restriction to light distribution or mounting height, except that, to prevent Light Trespass, if any flood or spot light is aimed, directed or focused so as to cause direct light from the Luminaire to be directed toward residential buildings on adjacent or nearby land, or to create Glare perceptible to pedestrians or persons operating motor vehicles on public ways, the Luminaire shall be redirected, or its light output reduced or shielded, as necessary to eliminate such conditions. [**Note:** This exempts most residential front-door lights, but not so-called Yard-Blaster wide-area flood lighting.]

D. Any Luminaire used to illuminate a public area such as a street or walkway shall utilize an energy efficient lamp such as a low pressure sodium lamp, high pressure sodium lamp or metal halide lamp. Mercury vapor lamps shall not be used due to their inefficiency and high operating costs and toxic mercury content. [**Optional:** No new installation of mercury vapor lighting shall be permitted after the effective date of this Ordinance, and the public shall be encouraged to remove and safely dispose of existing mercury vapor bulbs as soon as practicable.] [**Note:** Compact fluorescent lamps are not yet commercially available for roadway or wide-area lighting.]

E. Luminaires used in public areas such as roadway lighting and parking lots shall be designed to provide the minimum illumination recommended by the IESNA in the most current edition of the IESNA Lighting Handbook.

F. To protect light-sensitive wildlife in Pine Barrens areas identified as such by the NH Fish & Game Department, artificial lighting of any kind on the periphery of such areas shall be minimized and fully shielded to prevent any emission above a horizontal plane through the lowest light-emitting part of a Luminaire.

G. Whenever practicable, outdoor lighting installations shall include timers, dimmers, and/or sensors to reduce the overall energy consumption and eliminate unneeded lighting, particularly after 11 p.m.

H. Moving, fluttering, blinking, or flashing, neon or tubular lights or signs shall not be permitted, except as temporary seasonal holiday decorations. Signs may be illuminated only by continuous direct white light with illumination confined to the area of the sign and directed downward. (**Note:** A

requirement for direct white light would prohibit internally-lit signs, which are inherently impossible to shield.)

I. Luminaires mounted on a gas station canopy shall be recessed in the ceiling of the canopy so that the lens cover is recessed or mounted flush with the ceiling of the canopy and fully shielded. Luminaires shall not be mounted on the sides or top of the canopy, and the sides or facia of the canopy shall not be illuminated.

#### **4. Exemptions**

A. Luminaires used for public-roadway illumination may be installed at a maximum height of 25 feet and may be positioned at that height up to the edge of any bordering property.

B. All temporary emergency lighting needed by the Police, Fire or other emergency services, as well as all vehicular Luminaires, shall be exempt from the requirements of this Ordinance.

C. All hazard warning Luminaires required by Federal regulatory agencies are exempt from the requirements of this Article, except that all such Luminaires used must be red and must be shown to be as close as possible to the federally required minimum lumen output requirement for the specific task.

D. Luminaires used primarily for signal illumination may be mounted at any height to a maximum of 25 feet, regardless of lumen rating.

E. Seasonal holiday lighting and illumination of the American and State flags shall be exempt from the requirements of this Ordinance, providing that such lighting does not produce Glare on roadways and neighboring residential properties.

F. Installations existing prior to the enactment of this ordinance are exempt from its requirements. However, any changes to the existing lighting system, fixture replacements, or any grandfathered lighting system that is moved, must meet these standards.

#### **5. Temporary Lighting**

A. Any temporary outdoor lighting for construction or other purposes that conforms to the requirements of this Article shall be allowed. Non-conforming temporary outdoor lighting may be permitted by the Planning Board after considering:

- a) The public and/or private benefits that will result from the temporary lighting;
- b) Any annoyance or safety problems that may result from the use of the temporary lighting; and
- c) The duration of the temporary non-conforming lighting.

**Chapter V-J – Figure 3  
EXAMPLES OF POORLY  
SHIELDED LIGHTING**



**Intense, poorly shielded lighting illuminates rooftops, wasting energy and causing sky-glow**



**Powerful, unshielded flood light**

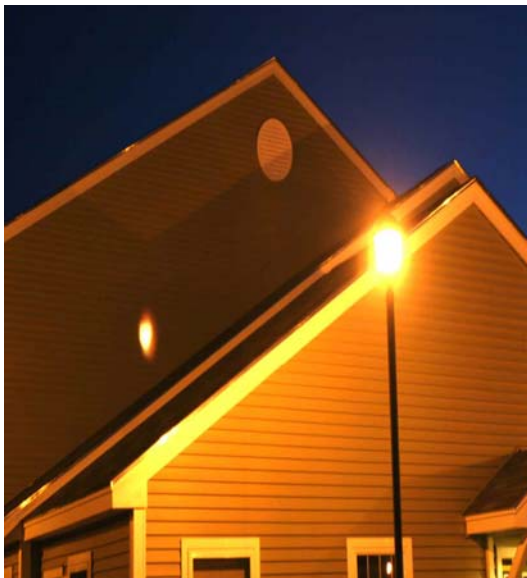

**Upward lighting causes glare and light pollution. Note shadows on roof lines**



**Angled, poorly shielded floodlight causes upward and down-street glare**



**Poorly shielded “wall-pack” light causes dazzling glare at a local fire station**



**Popular mercury vapor/metal halide light fixture causes intense glare and sky pollution**

**Chapter V-J Figure 4 –  
LOCAL EXAMPLES OF WELL  
SHIELDED LIGHTING**



**Library parking area – fully shielded lighting  
directs illumination entirely downward**



**Downward sign lighting**

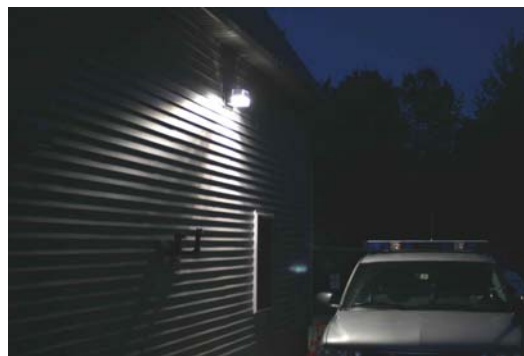

**Police station - well-shielded “wall-pack”  
fixture eliminates glare, directs light  
downward**



**Library facade – fully shielded fixtures  
provide good illumination where it is  
needed – on the ground**



**Shopping mall parking area - fully shielded  
provides good lighting without glare or sky  
pollution**

# Good Neighbor

# OUTDOOR LIGHTING

PRESENTED BY THE NEW ENGLAND LIGHT POLLUTION ADVISORY GROUP (NELPAG) AND SKY & TELESCOPE.

## What is good lighting?

Good outdoor lights improve visibility, safety, and a sense of security, while minimizing energy use, operating costs, and ugly, dazzling glare.

## Why should we be concerned?

Many outdoor lights are poorly designed or improperly aimed. Such lights are costly, wasteful, and distractingly glary. They harm the nighttime environment and neighbors' property values. Light directed uselessly above the horizon creates murky skyglow — the "light pollution" that washes out our view of the stars.

**Glare** Here's the basic rule of thumb: If you can see the bright bulb from a distance, it's a bad light. With a good light, you see lit ground instead of the dazzling bulb. "Glare" is light that beams directly from a bulb into your eye. It hampers the vision of pedestrians, cyclists, and drivers.

**Light Trespass** Poor outdoor lighting shines onto neighbors' properties and into bedroom windows, reducing privacy, hindering sleep, and giving the area an unattractive, trashy look.

**Energy Waste** Many outdoor lights waste energy by spilling much of their light where it is not needed, such as up into the sky. This waste results in high operating costs. Each year we waste more than a billion dollars in the United States needlessly lighting the night sky.

**Excess Lighting** Some homes and businesses are flooded with much stronger light than is necessary for safety or security.

## How do I switch to good lighting?

**1** Provide only enough light for the task at hand; don't over-light, and don't spill light off your property. Specifying enough light for a job is sometimes hard to do on paper. Remember that a full Moon can make an area quite bright. Some lighting systems illuminate

## Some Good and Bad Light Fixtures

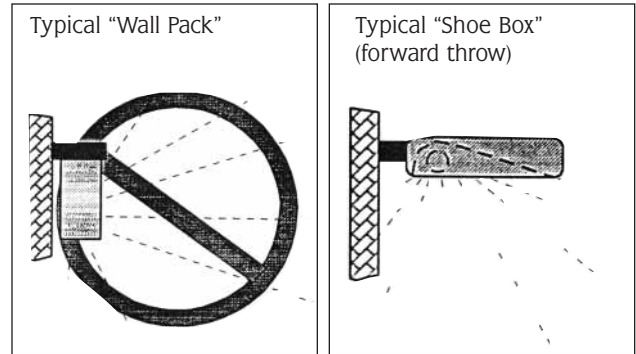

**BAD** **GOOD**

Waste light goes up and sideways      Directs all light down

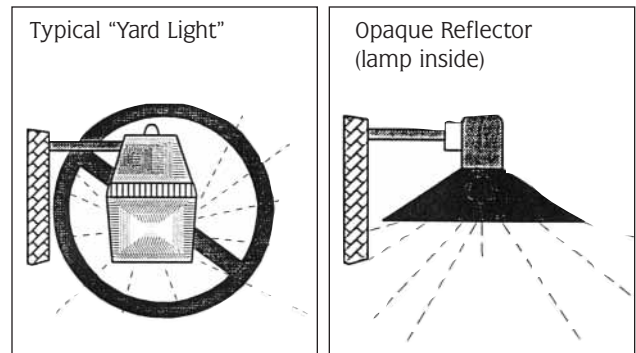

**BAD** **GOOD**

Waste light goes up and sideways      Directs all light down

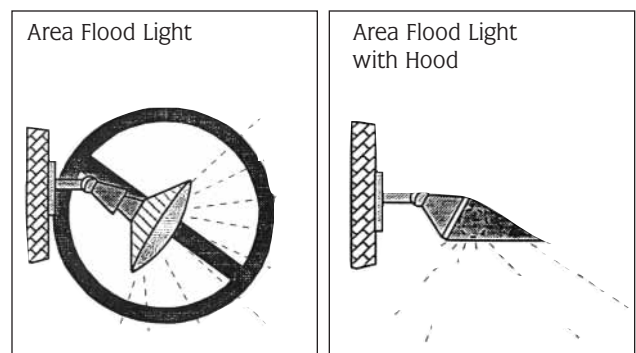

**BAD** **GOOD**

Waste light goes up and sideways      Directs all light down

areas 100 times more brightly than the full Moon! More importantly, by choosing properly shielded lights, you can meet your needs without bothering neighbors or polluting the sky.

- 2** Aim lights down. Choose “full-cutoff shielded” fixtures that keep light from going uselessly up or sideways. Full-cutoff fixtures produce minimum glare. They create a pleasant-looking environment. They increase safety because you see illuminated people, cars, and terrain, not dazzling bulbs.
- 3** Install fixtures carefully to maximize their effectiveness on the targeted area and minimize their impact elsewhere. Proper aiming of fixtures is crucial. Most are aimed too high. Try to install them at night, when you can see where all the rays actually go. Properly aimed and shielded lights may cost more initially, but they save you far more in the long run. They can illuminate your target with a low-wattage bulb just as well as a wasteful light does with a high-wattage bulb.
- 4** If color discrimination is not important, choose energy-efficient fixtures utilizing yellowish high-pressure sodium (HPS) bulbs. If “white” light is needed, fixtures using compact fluorescent or metal-halide (MH) bulbs are more energy-efficient than those using incandescent, halogen, or mercury-vapor bulbs.
- 5** Where feasible, put lights on timers to turn them off each night after they are no longer needed. Put home security lights on a motion-detector switch, which turns them on only when someone enters the area; this provides a great deterrent effect!

**Replace bad lights with good lights.**

You’ll save energy and money. You’ll be a good neighbor. And you’ll help preserve our view of the stars.

**What You Can Do To Modify Existing Fixtures**

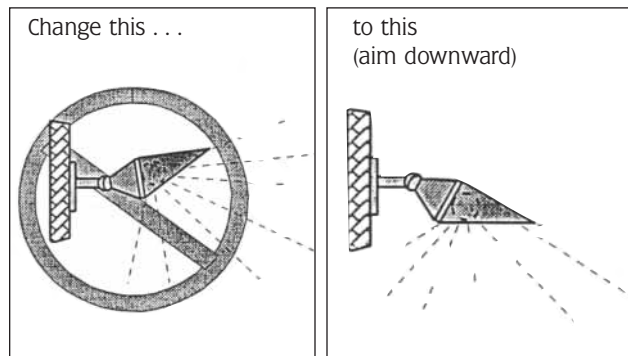

**FLOOD LIGHT**

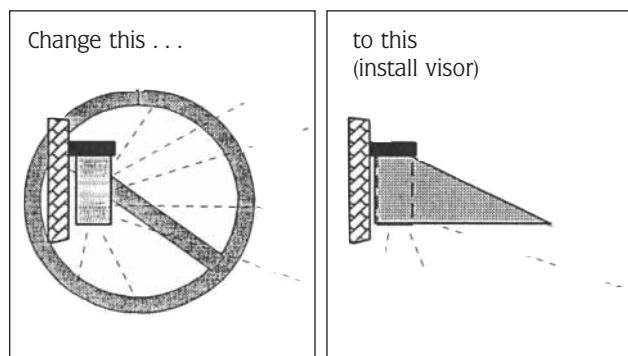

**WALL PACK**

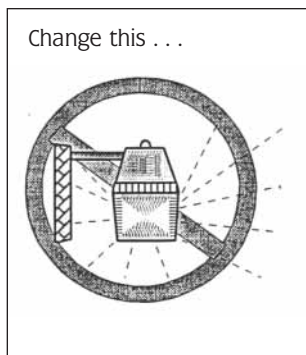

**YARD LIGHT**

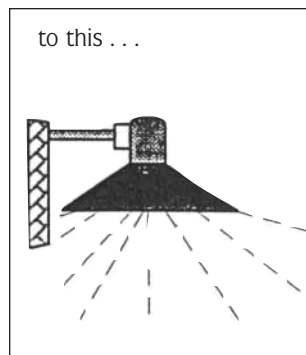

**OPAQUE REFLECTOR**

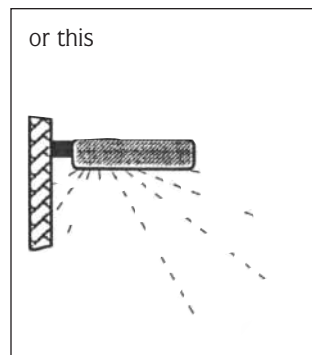

**SHOE BOX**

Presented by the **New England Light Pollution Advisory Group (NELPAG)** (<http://cfa-www.harvard.edu/cfa/ps/nelpag.html>)

and **Sky & Telescope** (<http://SkyandTelescope.com/>).

NELPAG and *Sky & Telescope* support the International Dark-Sky Association (IDA) (<http://www.darksky.org/>).

We urge all individuals and groups interested in the problems of light pollution and obtrusive lighting to support the IDA and subscribe to its newsletter. IDA membership costs \$30 per year; send your check to IDA, 3225 N. First Avenue, Tucson, AZ 85719, U.S.A.



Sky Publishing Corp.  
49 Bay State Road  
Cambridge, MA 02138  
[SkyandTelescope.com](http://SkyandTelescope.com)

# Ossipee Watershed Coalition

## Natural Resource Planning Guide

### Chapter V – K Sound

#### I. Introduction and the Importance of Serenity

One of the factors that attracts residents and tourist alike to this region is the rural atmosphere and peaceful natural surroundings; this feature does, in turn, help fuel the economy of the Ossipee Watershed. Both human and wildlife residents and visitors choose this region because of its comparatively undisturbed natural conditions and the serenity of its settings. The intrusion of avoidable, disruptive sound quality and quantity, i.e., noise, can discourage occupants from finding the circumstances they require here, driving them to seek more desirable locations elsewhere. Our continued, collective welfare demands that we carefully attend to the quality of all of our environmental surroundings, including the control of noise. Of course, the subjective nature of 'noise' makes balancing the rights and choices of everyone tricky to determine and achieve. Again, this comes down to sustainability- how to balance the choices such that our environment (in this case related to sound) and the rights of everyone are effectively protected.

#### II. Description of the Resource

As an unwanted plant in the garden is sometimes termed a weed, unwanted noise might be thought of as unwanted sound. However, we live in an environment of constant background sound – called the ambient sound level – whether that sound is the wind in the trees outdoors, or the television in the next room. It is the intensity of that sound, as well as its duration, that can have adverse impacts on human quality of life and on disturbance-sensitive wildlife. Humans tend to adapt to increased sound levels, but at high levels, sound has been scientifically shown to have adverse health and psychological effects. Thus, the quantity and quality of sound is an important factor in the quality of human life, and the quality of the larger natural environment. In a negative sense, “noise” can then be thought of as a pollutant.

#### Scientific Background

While its physical and emotional effects are difficult to define quantitatively, the noise level itself can be measured. The physics of sound as vibration in the atmosphere is well understood as “wave theory”. Most sounds are not pure tones, as in music, but rather a mixture of tones of varying amplitude, frequency, and duration. A jumble of tones difficult to separate as to source might be another way of thinking about noise.

The intensity of sound waves produce a sound pressure level, which is commonly measured in a unit called a *Decibel*. The decibel is a common logarithmic measurement, meaning sound measurement values increase by a factor of 10 each time, and not equally, as in normal counting, for example. It is used to accommodate a numbering scheme that encompasses a large range of values. This scale is used because the human ear can detect sounds more than a million times quieter than a jet aircraft during takeoff. This scale is termed the decibel level on the A-weighted scale, or *dBA* for short.

<sup>1</sup>Meaning sound measurement values increase by a factor of 10 each time, and not equally as in normal counting, for example)



## Standards

When considering sound levels in dBA, it is important to keep in mind that the logarithmic relationship is proportional by a factor of 10 (see above). The intensity of sound diminishes over distance as the energy of the sound wave is decreased by movement through the atmosphere. However, sound attenuation as measured in dBA is not a simple arithmetic function. Therefore, the most convenient way to understand sound level increase or decrease is to use *doubling rules*.

Sound sources are grouped into two types: *point* source and *line* source. Examples of a point source would range in scale from a bird call to a drag strip. Highways are line sources. The doubling rules are as follows:

- When the distance is doubled from a *line source*, the sound level decreases three (3) decibels.  
Example: 70 dBA at 50 feet → 67 dBA at 100 feet → 64 dBA at 200 feet
- When the distance is doubled from a *point source*, the sound level decreases six (6) decibels.  
Example: 95 dBA at 50 feet → 89 dBA at 100 feet → 83 dBA at 200 feet

*Perceived loudness* is also an important consideration. The human ear can detect a minimum change of 3 dBA in sound level; a change of 5 dBA is clearly noticeable. A 10 dBA change is perceived as twice (or half) as loud, a 20 dBA change is a fourfold change in loudness, and so on proportionally.

## Caveat

The science of sound measurement and the assessment of noise impacts is a complicated professional field. Many qualitative subtleties exist in the science, and the aesthetic experience of sound is very subjective. This narrative is intended only as a primer to orient the reader to a few simple fundamentals, but the subject invites careful research and understanding before any judgment can be made in real cases of noise impacts.

## **III Threats to the Region's Serenity**

Some noises are inevitable results of activities and services required to maintain accepted standards of living for residents and visitors. Yardwork and maintenance of homes and businesses generate periodic noise. Delivery of goods and services can be noisy, as can medium-term operations such as construction or logging. Transportation corridors concentrate vehicle sounds while engine noises arise from motorboats, snowmobiles, and off-road vehicles. Various forms of media can generate 'spill-over' noise when they can be heard by unappreciative neighbors of the primary listener(s).

Mindful of the subjectivity inherent in the perception of sounds as 'noise', it may be easier to identify extremes whose disruptive impact is clear to the general community. Disruptive noise may be a function of time (e.g., the 'quieter hours' of evening, night, and early morning; the frequency and/or duration of the noise; during activities requiring serenity such as sensitive nesting periods) and/or of space (e.g., adjacent to sanctuary space for people or wildlife; the sound-transporting character of water bodies). Ideally ordinances or regulations can be directed toward limiting these sorts of more clearly undesirable noises at least. Often such ordinances identify problem noise relative to generally existing background noise levels for particular areas.

**Serenity values** have been determined scientifically, and put into noise control policies by various federal and state agencies including the USDOT Federal Highway Administration, the US EPA, and the National Park Service. The following are examples of two such policies:

*“Lands on which serenity and quiet are of extraordinary significance and serve an important public need, and where preservation of those qualities is essential if the area is to serve its intended purpose shall not exceed 57 dBA in ambient sound level.”*

*“Picnic area, recreation areas, playgrounds, active sports areas, parks, and the exterior of residences, motels, hotels, schools, churches, libraries and hospitals should not exceed 67 dBA in ambient sound level.”*

The first statement relates to noise abatement criteria for national parks, monuments, and other special places. Actual scientific measurements were made nation-wide to support this policy; the ambient sound level of the Grand Canyon, for instance, is ~35 dBA. While these policies provide a regulatory baseline, it should be noted that most rural populations enjoy outdoor sound levels generally lower than 50dBA, often closer to 40 dBA. Therefore, serenity value is relative and location-specific, and should be determined by scientific measurement in order to set a “local standard” against which to evaluate potential noise impacts.

For comparison, well-documented sound levels for a range of sources and locations are listed the following table.

**Chapter V-K, Table 1**

Noise Source	dBA Level
Jet Engine at 300'	130
Bulldozer at 50'	85
Heavy truck traffic @ 55mph @ 50'	83*
Medium truck traffic @55mph @ 50'	78*
Auto traffic @ 55 mph @ 50'	67*
Conversation @ 5 to 10'	60
Rural residential	40
Bedroom	40
Secluded woods	30

\* Highway noise varies with speed. Federal maximum for heavy and medium trucks is 87 dBA measured at 70 mph.

Finally, guidelines for **sustained ambient sound levels** have been established by various agencies for the protection of public health and welfare. Both the US EPA and the World Health Organization specify a maximum 55 dBA for outdoor environments, and 45 dBA for indoor environments. However, as noted in the table above, ambient sound levels in rural communities may be considerably lower than these guidelines.

### **Current Regulations Regarding Noise Control**

The Air Resources Division of the NH DES indicates that "mobile sources of noise and workplace noise are regulated at the federal level. When a major highway, airport, or railroad is being built or significantly expanded, the associated noise levels must comply with standards set forth by the Federal Highway Administration, the Federal Aviation Administration, and the Federal Transit Administration. Noise in the workplace is regulated by the Occupation Safety and Health Administration (OSHA). Additionally, noise is one of a variety of occupational exposures the can be monitored upon the

employer's request as part of the New Hampshire Department of Health and Human Services' On-Site Safety and Health Consultation program".

In New Hampshire, many communities have a "noise ordinance" clause embedded within their zoning ordinance; often this clause amounts to little more than a generally worded nuisance control with no stated standards to be used in deciding problem cases. In some communities, a performance-based zoning standard is used to control noise and other environmental issues that may extend beyond the boundary of a proposed development project. Specifically, such a zoning ordinance may require that there be *no net increase* above existing ambient sound levels beyond the property boundary, to be determined by engineering investigation and scientific principles.

For community planning purposes and to establish a working baseline, a general assessment of existing noise sources and desirable ambient sound levels can be made using the rules and standards noted above. An inventory of point and line sources can be made, and general noise level conditions in the Ossipee Watershed Coalition's service area might be mapped, as shown hypothetically in the figure below.

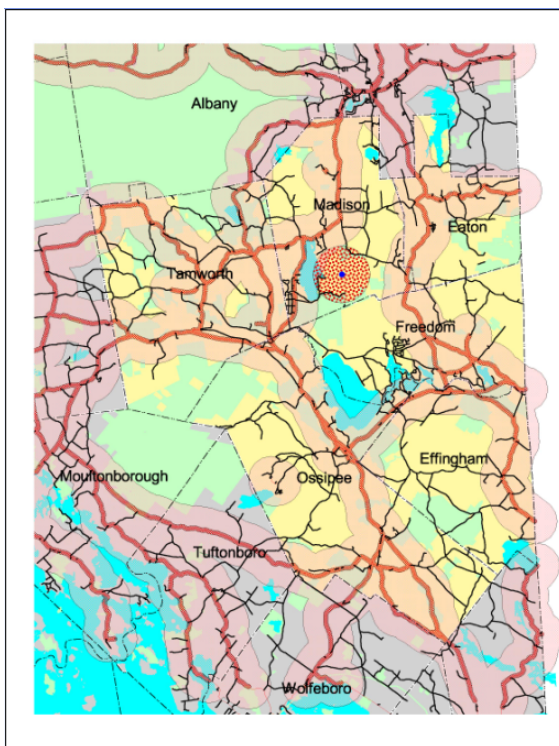

Chapter V-K, Figure 1

- Municipal Boundaries
- Local Roads and Highways
- Interstate/Turnpike
- State Roads
- Local Roads
- Hypothetical Point Source
- Point Source Buffer to Ambient Sound Level (6400')
- Highway Noise Half Loudness (75 dBA)
- Highway Noise Quarter Loudness (65 dBA)
- Conservation Land Parcels Conservation & Public Lands
- Major Water Features

This map shows typical loudness decay buffers along major highways (line sources) and relative to a hypothetical point source such as a rock crushing plant. The highway buffers are classed by diminishing loudness which decays to about 65 dBA; it requires more than 50,000 feet to reach an ambient sound level in the mid-40's. The point source would reach ambient levels in about 1.25 miles. No topographic or vegetative sound level effects are included in this quick analysis.

#### IV. Recommendations

1. Communities should determine ambient noise levels for the various regions within their jurisdiction. This information can form a baseline against which to compare exceptional existing or future sources of disruptive sound. Regional baselines can define upper limits for acceptable noise production at least on a frequent or continuing basis.
2. Communities should identify especially important noise-sensitive areas within their jurisdiction and act first to establish and enforce noise limitations affecting them.

3. Communities may find it beneficial to clarify prohibited levels and circumstances of noise production by spelling out a specific Noise Control Ordinance, perhaps modeled on those described in section VII below.

## **V. Resources/Links**

Air Resources Division of the NH DES – for further description of the noise issue and links to additional information: <http://www.des.state.nh.us/ard/noise/index.html>

The Noise Pollution Clearinghouse – is a national non-profit organization formed to facilitate access to information and to stimulate citizens and communities to become active to "strengthen laws and governmental action to control noise pollution":  
<http://www.nonoise.org/>

## **VI. References**

Air Resources Division of the NH DES, <http://www.des.state.nh.us/ard/noise/index.html>

## **VII. Sample Ordinances**

Many of the existing Noise Ordinances relate to urban circumstances that do not match conditions within the Ossipee Watershed well. The following sample ordinance is drawn from York, Maine, a locality that more nearly approximates our setting. Many other examples may be viewed at:  
<http://www.nonoise.org/lawlib/cities/cities.htm>

### **TOWN OF YORK, MAINE** **NOISE ORDINANCE**

An Ordinance providing for the reduction and elimination of noise by establishing maximum noise levels upon and between premises, prohibiting certain noise activities, and providing for inspection, offenses and penalties in the Town of York, Maine.

**SECTION 1. SHORT TITLE:** "The Town of York Noise Control Ordinance".

**SECTION 2. PURPOSE:** It is recognized that the Town of York has a compelling interest in ensuring for its residents an environment free from excessive noise that may jeopardize their health or welfare or degrade the quality of life. This ordinance is enacted to protect, preserve and promote the health, safety, welfare and quality of life for the citizens of York through the reduction, control and prevention of loud and unreasonable noise. The Town has conducted studies of decibel levels found in York: and this ordinance is referenced to the scientific facts resulting from these studies: Ad Hoc Noise Control Ordinance Committee findings, with Planning Board review, September 10, 1984 and (report from a recognized Scientific Noise Measurement agency).

**SECTION 3. NOISE LEVELS:**

3.1 It shall be unlawful for any person to emit or cause to be emitted any noise beyond the boundaries of his/her premises in excess of the noise levels established in these regulations.

3.2 NOISE LEVEL STANDARDS

Sound from any source controlled by this ordinance shall not exceed the following limits at the lot line of the "receiving" property:

SOUND PRESSURE LIMITS  
(Decibel levels (dB) measured in the A scale).

<u>Zoning Districts</u>	<u>Sunday through Thursday</u>		<u>Friday and Saturday</u>	
	day	night	day	night
<u>Route 1 Ind./Comm.</u> H-1, H-2, H-3	<u>7 am - 11 pm*</u> 68	<u>11 pm - 7 am</u> 55	<u>7 am - 11 pm*</u> 68	<u>11 pm - 7 am</u> 55
<u>Commercial</u> Village B and Harbor B-2	<u>8 am - 10 pm</u> 60	<u>10 pm - 8 am</u> 50	<u>8 am - 11 pm</u> 60	<u>11 pm - 8 am</u> 50
<u>Beach Mixed Use</u> R1, R1A, R1B, RES 5	<u>8 am - 10 pm</u> 65	<u>10 pm - 8 am</u> 50	<u>8 am - 11 pm</u> 65	<u>11 pm - 8 am</u> 50
<u>Resort Commercial**</u> RC	<u>8 am - 11 pm</u> 74	<u>11 pm - 8 am</u> 57	<u>8 am - 11 pm</u> 74	<u>11 pm - 8 am</u> 57
<u>Residential &amp; General</u> <u>Vill:</u> A, B-1, B-2, B-3, C-1, C-2, D-1, D-2 <u>Harbor:</u> A, B-1	<u>8 am - 9 pm</u> 55	<u>9 pm - 8 am</u> 45	<u>8 am - 11 pm</u> 55	<u>11 pm - 8 am</u> 45

\* The time 7 am to 11 pm corresponds to the two daytime shifts of the 3-shift industrial workday: 7 am - 3 pm, 3 pm 11 pm, 11 pm - 7 am.

\*\* For the purpose of this ordinance, the amusement park portion of York's Wild Kingdom shall be regarded as occupying the Resort Commercial Zone: this does not supersede existing Town zoning or any other new zoning districts that may be formed from time to time.

- a. Because the Decibel A Scale (dB(A)Scale) responds most closely to the range of sounds audible to the human ear, the dB(A) Scale shall be used for all sound pressure measurements; and a violation of the standards of Section 3.2 shall be deemed to constitute a violation of this Ordinance.
- b. Where the emitting and receiving premises are in different zones, the limits governing the stricter zone shall apply to any regulated noise entering that zone.

3.3 Resort Commercial Buffer Zone

- a. Because the intensity of unimpeded sound naturally decreases proportionally to the inverse square of the distance away from its source, it is deemed reasonable to allow for a buffer strip between the naturally more noisy Resort Commercial (RC) Zone and the naturally less noisy mixed residential zones which surround the RC Zone. The purpose of said buffer zone is to provide sufficient space within which to construct sound barriers, including but not limited to, walls or earth berms to effect a reduction where needed, of sounds emanating from the Resort Commercial and traveling into said surrounding mixed residential zones.
- b. The Buffer Zone shall extend 10 feet within the Resort Commercial Zone and 10 feet into the abutting zones. The decibel level at the Buffer Zone boundary within the Resort Commercial

Zone shall be 74 dB(A) or less from 8 A.M. to 11 P.M.: 57 dB(A) or less from 11 P.M. to 8 A.M. Within the Buffer Zone at the boundary of the Resort Commercial Zone, the noise limit shall be 69 dB(A) or less from 8 A.M. to 11 P.M.: 54 dB(A) from 11 P.M. to 8 A.M. At the outer edge of the Buffer Zone within the abutting zone, the noise level shall be less than 65 dB(A) from 8 A.M. to 11 P.M.: 50 dB(A) from 11 P.M. to 8 A.M.

3.4 Temporary Exceedance of Sound Pressure Limits

The levels specified in Section 3.2 may be exceeded by 10 dB(A) for a single period, no longer than 15 minutes, in any consecutive 24 hour period.

3.5 EXCLUSIONS

These levels shall not apply to noise emitted by or related to:

- a. Natural phenomena.
- b. Church bells rung as part of any official church ceremony or service, and tower clock bells ringing the hour during daytime hours.
- c. Any siren, whistle or bell lawfully used by emergency vehicles or any other alarm systems used in any emergency situation, provided, however, that burglar alarms not terminated within thirty (30) minutes after being activated shall be unlawful.
- d. Warning devices required by OSHA or other State or Federal regulations.
- e. Lawful emergency maintenance or construction such as, but not limited to, repair of a broken water main or replacement of overhead power lines.
- f. Noise created by any recreational activities which are permitted by law and for which any temporary license or permit required by the Town has been granted, including, but not limited to, parades, special sporting events, occasional public concerts and fire works displays.

SECTION 4. SPECIFIC PROHIBITIONS

- 4.1 The following acts are declared to be loud, disturbing and unnecessary noises in violation of this ordinance:
- a. Owning, possessing or harboring any animal or bird which frequently or for continued duration, makes loud and unreasonable sounds which create a noise disturbance across a real property boundary. For the purpose of this ordinance, a barking dog shall mean a dog that barks, bays, cries, howls or makes any other noise continuously and/or incessantly for a period of ten minutes or barks intermittently for one-half hour or more to the disturbance of any person at any time of day or night, regardless of whether the dog is physically situated in or upon private property; provided, however, that a dog shall not be deemed a "barking dog" for the purpose of this Article, if, at the time the dog is barking or making any other noise, a person is trespassing or threatening to trespass upon private property in or upon which the dog is situated or for any other legitimate cause which teased or provoked the dog.
  - b. Using, operating or permitting to be played in a loud and unreasonable manner any radio receiving set, musical instrument, phonograph, loud speaker, sound amplifier, or other machine or device for the producing or reproducing of sound which is cast upon the public streets for the purpose of commercial advertising or attracting the attention of the public to any premise or structure without proper licensing.
  - c. The loud and unreasonable shouting and crying of peddlers, hawkers and vendors which disturbs the peace and quiet of the neighborhood.

## SECTION 5. BOAT NOISE

Administration of this Ordinance concerning noise originating from any waterway in the Town of York under the jurisdiction of the York Harbor Master shall likewise be under the jurisdiction of the York Harbor Master. In the lawful pursuit of his authority under this Ordinance, the Harbor Master may call upon any Town of York Noise Control Officer or trained State personnel for assistance.

- 5.1 All watercraft on the waters of the Town of York under the jurisdiction of the York Harbor Master shall use an engine muffler in compliance with the Maine Boat Law, Article 15, as it may be amended from time to time.
- 5.2 Watercraft on waters under the jurisdiction of the York Harbor Master shall be prohibited from creating excessive noise as a result of being operated at greater than reasonable and prudent speed, as defined in the Maine Boat Law, Article 11, as amended from time to time. Excessive boat noise shall be 65 dB level, A Scale, or greater, measured frequently over a 5 minute period on the boundary of private property abutting the shoreline.

## SECTION 6. MEASUREMENT PROCEDURES

For the purpose of determining noise levels as set forth in this Ordinance, the following guidelines shall be applicable.

- 6.1 All personnel conducting sound measurements shall be trained in the current techniques and principles of sound measuring equipment and instrumentation according to A.N.S.I. I or II Metering Techniques.
- 6.2 Instruments used to determine sound level measurements shall conform to Standards of A.N.S.I. Type I or Type II meters.

## SECTION 7. RIGHT OF ENTRY FOR INSPECTION

- 7.1 For the purpose of determining compliance with the provisions of this Ordinance, the Noise Control Officer is authorized to make inspections of all noise sources and to take measurements and make tests whenever necessary to determine the quantity and character of noise. He may enter any property with the consent of the owner or his agent. If consent is not granted, the Officer may seek an administrative warrant from District Court.

## SECTION 8. ENFORCEMENT

- 8.1 The Noise Control Officer is directed to enforce the provisions of this Ordinance, to issue a summons to any person who violates a law or ordinance which the official is empowered to enforce; and
- 8.2 When specifically authorized by the municipal officers, to represent the municipality in District Court in the prosecution of alleged violations of ordinances or laws which the official is empowered to enforce.
- 8.3 No person shall interfere with, oppose or resist an authorized person charged with the enforcement of this Ordinance while such person is engaged in the performance of his duty.
- 8.4 Violations of this Ordinance shall be prosecuted in the same manner as other civil violations, provided, however, that in the event of an initial violation of the provisions of this Ordinance, a

written notice shall be given to the alleged violator which specifies the time by which the condition shall be corrected. No complaint or further action shall be taken in the event the cause of the violation has been removed, the condition abated or fully corrected within the same period specified in the written notice. The notice shall state that unless corrections are made within the allotted time, the violator is subject to prosecution pursuant to provisions of this ordinance.

- 8.5 In the event the alleged violator cannot be located in order to serve the notice of the intent to prosecute, the notice as required herein shall be deemed to be given upon mailing of notice by registered or certified mail, return receipt requested, to the alleged violator at his last known address or at the place where the violation occurred, in which event the specified time period for abating the violation or applying for a variance shall commence at the date of the day following the mailing of such notice. Subsequent violations of the same offense shall result in the immediate filing of a criminal complaint.

## SECTION 9. DEFINITIONS

The following definitions shall apply in the interpretation and enforcement of this Ordinance:

Ambient Noise. Ambient noise is the all-encompassing noise associated with a given environment, being a composite of sounds from many sources near and far.

Compliance Report. The source document prepared by the law enforcement officer after receiving a complaint from a complainant detailing an incident. The report, when duly signed by the officer, shall become a matter of record. The report shall remain on file until its use requires destruction or retirement. Each complaint shall be investigated by the responding officer and attested to as to the validity of said complaint.

Decibel. Decibel shall mean the practical unit of measurement for sound pressure level the number of decibels of a measured sound is equal to 20 times the logarithm to the base 10 of the ratio of the sound pressure of the measured sound to the sound pressure of a standard sound (20 micropascals) , abbreviated dB. The abbreviation dB(A) shall refer to readings taken on the A-weighted scale.

Emergency. Shall mean any occurrence or set of circumstances involving actual or imminent physical trauma or property damage which demands immediate action.

Emergency Vehicle. Shall mean any private, Town, State or Federal motor vehicle authorized to have sound warning devices such as sirens and bells which can lawfully be used when responding to an emergency.

Emergency Work. Shall mean work made necessary to restore property to a safe condition following an emergency, or work required to protect persons or property from exposure to imminent danger.

Motor Vehicle. Shall mean any vehicle which is propelled or drawn on land or water by a motor, such as, but not limited to, passenger cars, trucks, truck-trailers, semi-trailers, campers, go-carts, snowmobiles, amphibious craft on land, dune buggies, racing vehicles, motorcycles, trail bikes or mini-bikes and watercraft. Seaplanes, for the purpose of this Ordinance, shall not be defined as watercraft.

Muffler. Shall mean a device for abating sounds such as escaping gases from an internal combustion engine.

Municipal Officers. Duly elected officials of the Town, commonly known as Selectmen.

Noise Control Officers. Shall mean a municipal employee trained in the use of sound level



meters. This Ordinance shall normally be enforced by a police officer, but also may be enforced by the Code Enforcement Officer during normal working hours, or the Harbor Master.

Person. Shall mean any individual, firm, partnership, association, syndicate, company, trust, corporation, municipality, agency or political or administrative subdivision of the State or other legal entity of any kind.

Premises. Shall mean any building, structure, land or portion thereof, including all appurtenances, and shall include yards, lots, courts, inner yards, and real properties without buildings or improvements, owned or controlled by a person.

Property Line. Shall mean that real or imaginary line along the ground surface and its vertical extension which (a) separates real property owned or controlled by any person from contiguous real property owned or controlled by another person, and (b) separates real property from the public right-of-way.

Sound Level Meter. Shall mean an instrument for the measurement of sound levels conforming to A.N.S.I. Type 1 and Type II Standards.

Summons. An order to comply or appear.

9.1 Words Not Specifically Defined in this Ordinance.

Any words or phrases in this Ordinance not covered under "definition" shall assume their common dictionary definition.

SECTION 10. PENALTIES

- 10.1 Any person or persons, firm or corporation who violates any of the provisions of this Ordinance, or who fails to conform to any of the provisions thereof, or who fails to obey any lawful order of any officer charged with the enforcement of the provisions of this Ordinance, or other persons who shall assist in the violation of this Ordinance. shall be guilty of a civil violation and upon conviction thereof shall be fined not less than One Hundred (\$100.00) Dollars, but not more than Five Hundred (\$500.00) Dollars. Each violation or failure to comply constitutes a separate offense. The municipality may be awarded reasonable attorneys' fees and costs incurred in enforcing this Ordinance.

SECTION 11. SEVERABILITY

Any provisions of the Zoning Ordinance of the Town of York which are more stringent than those set forth herein shall remain in force. It, for any reason, any word, clause, paragraph or section of this Ordinance shall be held to make the same unconstitutional, the ordinance shall not hereby be invalidated and the remainder of this ordinance shall continue in effect.

SECTION 12. EFFECTIVE DATE

This ordinance shall become effective upon adoption by Town Meeting.

SECTION 13. AMENDMENTS

This ordinance may be amended by majority vote of any Town Meeting.

# Ossipee Watershed Coalition

## Natural Resources Planning Guide

### Chapter VI Economy, Tourism & Growth

#### I. Economy

It is recognized that economy, tourism and growth are not “natural resources;” however, they are so closely tied to our natural resources, both in value and use, that coverage in the Guide seemed appropriate. New Hampshire is in a prime location to support an expanding economy, with a variety of natural resources and infrastructure to sustain communities and continued economic growth (see Figure 1 below). Most destinations in NH, including the Ossipee Watershed, are within a day’s drive from major population centers in Boston, New York, and Montreal. NH is well-positioned as a lower cost alternative to expensive metropolitan regions and tourist destinations in New England. Year-round tourism is now the state's leading industry with many visitors coming to enjoy the state's beaches, mountains, and lakes. Statistics on forest-based tourism, recreation and second home activity show annual contribution of open space related activities in NH was \$8.2 billion in 1996/7. This comprised about 25% of the state’s gross state product. Forestry related activities contributed \$3.9 billion to the NH economy. (See Chapter V.E.)

N.H. has matched U.S. nonfarm job growth, since the end of the last U.S. recession (Nov 01), while N.E. lags behind.

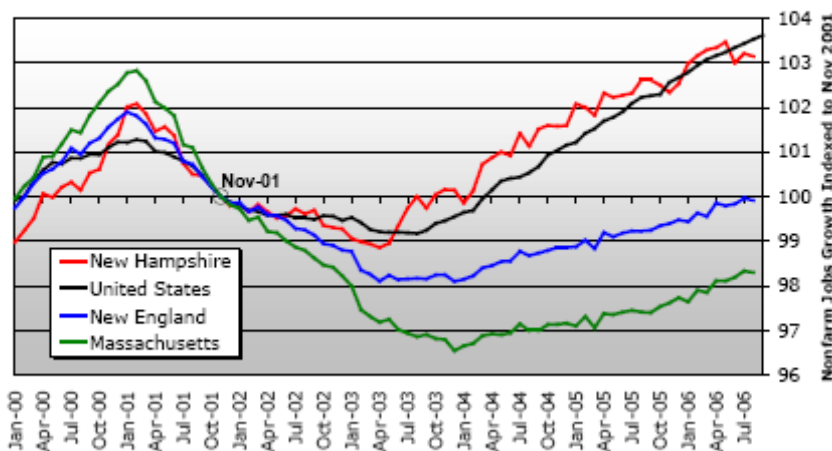

**Figure 1: Job Growth in New Hampshire from 2000-2006.** Job growth in New Hampshire has outpaced New England and Massachusetts, but kept pace with U.S. growth. *Source: New Hampshire Economic & Labor Market Information Bureau, 2007.*

With more than 1.3 million people and 234 diverse municipalities, New Hampshire’s economy is largely dependent on the success of the New England region, (which is largely influenced by Massachusetts), in addition to the United States and the greater global economy. Consequently, the state’s economic future cannot be separated from regional, national, and global trends and events. These statistics highlight the importance for the Ossipee Watershed to consider long term sustainability and the current reliance on energy, food, and other resources that are transported great distances. If more emphasis is placed on supporting the regional economy there will be greater opportunities for balancing growth with resource

protection for future generations. (For a more in depth discussion of the relationship between global and local economies see Chapter VII.)

Projections for Carroll County’s job growth from 2004 through 2014 are promising and slightly greater than that for the state as a whole (Figure 2). Health care and social assistance lead New Hampshire Economic and Labor Market Information Bureau estimates, with a projected increase of 33.9%, while arts, entertainment and recreation are second with an increase of 29.8%. Occupations with the most openings during the projection period include: cashiers, retail salespersons, waiters and waitresses, and food preparation and serving workers. Forest-based manufacturing contributes 8% of NH’s manufacturing and employs 9400 people. Figure 3 provides employment growth projections for the main industries in Carroll County.

## Carroll County Statistics (rank statewide by county)

	Rank
<b>Population</b> (2005 Census) . . . . .	47,439 8th
<b>Area</b> (square miles) . . . . .	933.9 4th
<b>Population Density</b> (persons per square mile). . . . .	50.8 8th
<b>Per Capita Personal Income</b> (2004 BEA) . . . . .	\$33,763 4th
<b>Projected employment growth</b> . . .	16.5% 3rd
<b>Largest town</b> . . . . .	Conway

Tables 2 & 3: Carroll County Statistics & Projected Job Growth by Industry (2004-2014).  
Source: *New Hampshire Economic & Labor Market Information Bureau, 2007.*

### II. Recreation & Tourism

According to the Institute for New Hampshire Studies at Plymouth State University, travel and tourism is New Hampshire’s largest industry in terms of jobs and attracting dollars from out of state. In 2005, trips in NH for recreation and business totaled \$33.4 million, broken down by season accordingly: 39% in summer; 23% in fall; 19% in winter; and 19% in spring. In 2005, these visitors spent \$4.136 billion, an increase of 1.9% from 2004, including \$112.5 million in rooms and meals taxes. This spending supported 66,700 direct full-time and part-time jobs.

On an annual basis, the majority of tourists visiting New Hampshire are from Massachusetts (46%), (according to the New Hampshire visitors surveys from 2004 and 2005 completed by the Division of Travel and Tourism), followed by those from elsewhere in New Hampshire (11.2%), and New York (8.5%). The top three activities favored by tourists included: (1) touring/sightseeing – particularly in summer and fall seasons; (2) dining – particularly in winter and spring seasons; and (3) shopping – more so in fall and winter. Also noticeable was the reported incidence of those participating in various season-specific active, outdoor recreational activities such as: hiking/biking – particularly in spring and summer; beach/waterfront and parks – in summer; and snow skiing/boarding – in winter.

Records also show that in 2001, international overnight tourists were primarily from Canada (294,000), the United Kingdom (51,200) and Germany (20,700). In 2004, visitors from Canada reached 328,600, averaging three nights and spending 46% more in 2004 than in 2000.

### Carroll County Employment Projections by Industry

Industry	Base 2004	Projected 2014	Change	Percent Change
<b>Total Employment</b>	23,040	26,834	3,794	16.5%
Agriculture, Forestry, Fishing & Hunting	97	109	12	12.4%
Mining	33	34	1	3.0%
Construction	1,242	1,505	263	21.2%
Manufacturing	1,155	1,125	-30	-2.6%
Utilities	84	87	3	3.6%
Wholesale Trade	316	356	40	12.7%
Retail Trade	3,920	4,667	747	19.1%
Transportation & Warehousing	324	371	47	14.5%
Information	338	308	-30	-8.9%
Finance & Insurance	519	537	18	3.5%
Real Estate & Rental & Leasing	332	399	67	20.2%
Professional, Scientific, & Tech Svcs	473	585	112	23.7%
Mgmt of Companies & Enterprises	161	179	18	11.2%
Administrative & Waste Mgmt Svcs	408	504	96	23.5%
Educational Services	1,915	2,364	449	23.4%
Health Care & Social Assistance	2,470	3,307	837	33.9%
Arts, Entertainment, & Recreation	974	1,264	290	29.8%
Accommodation & Food Services	4,312	4,921	609	14.1%
Other Services (Ex Government)	531	570	39	7.3%
Government	1,137	1,191	54	4.8%
Total Employment (Ex Self-employed)	20,741	24,383	3,642	17.6%
Self-employed & Unpaid Family Workers	2,299	2,451	152	6.6%

The Ossipee Watershed includes parts of the Lakes Region and White Mountains and is one of the state's more popular tourist destinations. The region's freshwater resources in addition to forests, wildlife, scenic vistas, recreational opportunities and rural character attract significant numbers of visitors each year, creating jobs for local residents, a healthy real estate market, etc. The Watershed's lakes, streams and other natural features are described in other chapters, so these are not repeated here. Suffice it to say that the characteristics of the region's natural resources is what draws tourists here in the first place, and therefore is so intricately woven into our economy and the fabric of everyday life in our Watershed.

**Freshwater Resources as They Relate to Economy and Tourism:**

According to studies by the New Hampshire Lakes Association (NHLA), freshwater resources contribute nearly \$1.2 billion to the state from the nearly 14.7 million visitor days spent boating, fishing, and swimming each year. Lakes, rivers and ponds are valuable natural and economic resources that clearly benefit New Hampshire's local communities, generating income from residents, in-state property owners, and tourists who spend money on water-based recreational activities, as well as waterfront property owners who pay a purchase and tax premium to be located there (see Table 1 below).

Use	Participation	Total Sales	Household Income	Jobs (full- and part-time)
Boating	3.6 million visitor days	\$328 - \$450	\$126 - \$128	3,400 - 5,700
Fishing	3.1 million visitor days	\$245 - \$352	\$84 - \$103	2,100 - 4,300
Swimming	8.0 million visitor days	\$269 - \$380	\$109 - \$111	3,800 - 5,000
Drinking Water	191 thousand customers	\$276 - \$301	\$75 - \$147	1,900 - 2,600
<b>TOTAL</b>		<b>\$1,118 - \$1,483</b>	<b>\$394 - \$489</b>	<b>11,200 - 17,600</b>

**Table 1: Annual Impacts of Select Surface Water Uses on New Hampshire's Economy**  
 (All Dollar Values are in Millions of 2002 Dollars) *Source: NHLA Phase II Report, 2003.*

Surface waters are also important for drinking water supplies today and for the future. Public water suppliers also depend upon these resources to serve customers and businesses. NHLA reports that nearly 200,000 households and businesses rely on public drinking water from surface water supplies. This generates approximately \$75 million to \$150 million in annual household income, 1,900 to 2,600 full and part-time jobs, and \$276 million to \$300 million in annual total sales.

In a 2004 survey of New Hampshire residents, the most important reason people cited for visiting a lake or pond is because it offers the best fishing, boating, or swimming, followed by the overall beauty of the area. Nearly three quarters of the state's residents (71%) plan on taking some type of trip or vacation in the next 12 months that will include freshwater boating, fishing, or swimming.

### III. Growth

Beyond tourism, another major factor is population growth within the Watershed. Chapter III describes the status of each Watershed town and its growth projections. A summary of these statistics (see Table 2 below) indicates that on average the watershed towns will grow about 38% over the 2000-2025 period. Since data were available through 2005 (already five years into that 25 year period), changes in density (people per square mile) and net population growth were also examined for 2005-2025 (again, see Chapter III). On average, the net population change is projected to be 741 more individuals per town (a range from 471 to 1759) and an overall density increase of 16.3 people per square mile over this 20 year period.

**Table 2: Ossipee Watershed Towns-Growth Statistics\*\* (NH Office of Energy Planning?)**

	2000-2025	2005-2025	2005-2025
Town	% Growth	Net Density Increase*	Net Pop. Increase
Effingham	38.9	14.2	555
Freedom	39.0	16.1	549
Madison	32.5	18.9	728
Ossipee	38.5	24.9	1759
Sandwich	34.7	5.3	471
Tamworth	43.9	18.6	1104
<b>Ave.</b>	<b>37.9</b>	<b>16.3</b>	<b>741</b>

\* People/Sq. Mile

\*\* See Chapter III

### IV. Current and Potential Impacts

The biggest potential risk concerning our local economy, tourism and growth is that people will simply stay away. This can be brought on by a myriad of factors (weather, fuel prices, real estate costs, the general economy, etc.), but certainly the quality of the natural environment is a major reason why people travel to this area. For example, the most important reasons people stay away from specific New Hampshire freshwater bodies include: overcrowding of people and boats, nuisance plant growth, and poor water quality (see Figure 4 below). Six out of 10 people surveyed said that they feel that the federal government, state government, and local government should be equally responsible for protecting and improving environmental conditions and overall characteristics of freshwater bodies in New Hampshire.

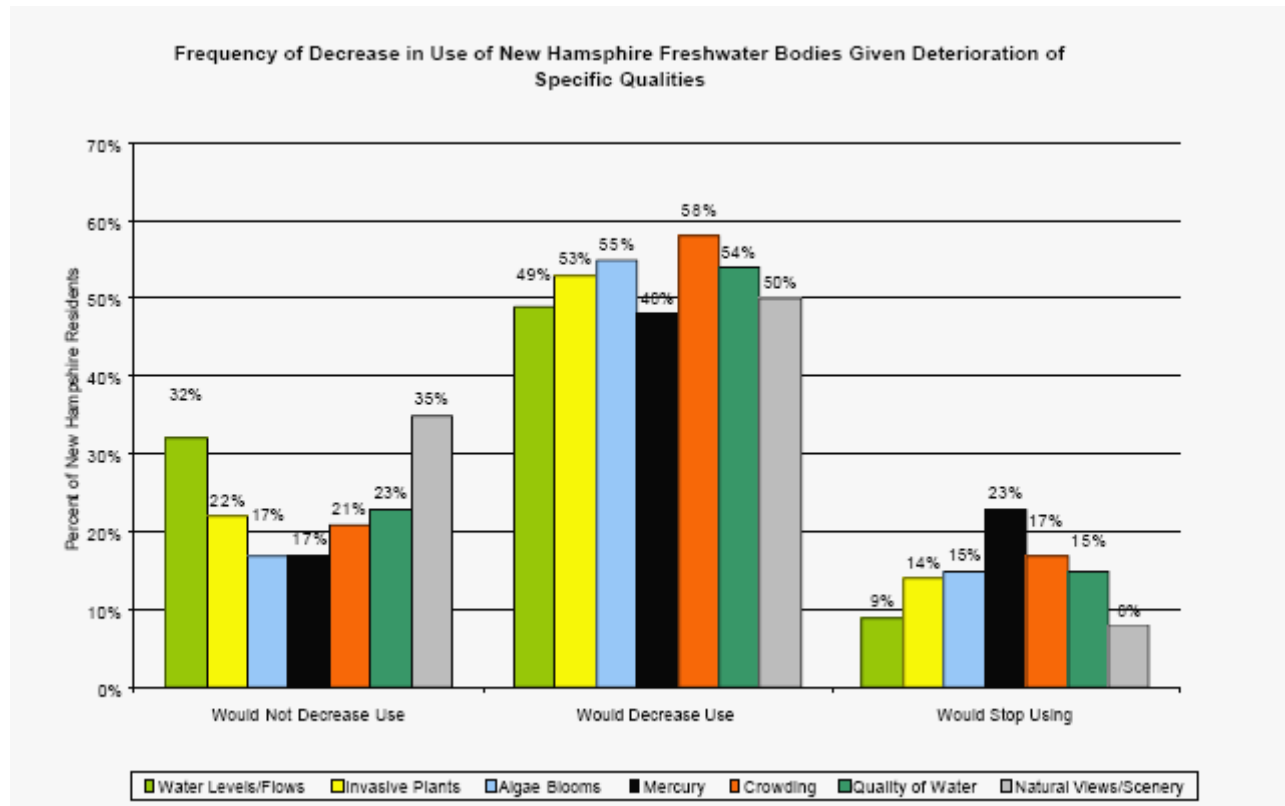

The NHLA study illustrates how the economic value of a local natural resource can be determined and what would be lost if that resource is degraded. In essence, the tourism-based economy of New Hampshire would be affected by a decline in water quality, with half to two-thirds of visitors decreasing or ceasing their visiting days to a particular waterbody if they perceived a decline in water clarity and purity, natural views and scenery, crowding levels, and water levels and flows. Other findings of the study show that overall, perceived degradation of water clarity and purity will result in the greatest economic loss to New Hampshire. Perceived declines in water clarity and purity would result in about **\$51 million of lost sales, \$18 million in lost income and more than 800 lost jobs statewide.**

## V. Recommendations

- A. Planning Boards, Conservation Commissions and other town boards should prioritize the important natural resources in each town and weigh the relative risks of not having proper zoning and other controls (including BMPs) in place to protect the economic and tourist base.
- B. Use this Guidebook to frame zoning ordinances and BMPs that will protect the local natural resources important to our economy and tourism in a sustainable manner.

## VI. References & Links

Institute for New Hampshire Studies at Plymouth State University: <http://oz.plymouth.edu/inhs>

New Hampshire Economic and Labor Market Information Bureau:

<http://www.nhes.state.nh.us/elmi/index.html>

[http://www.nhes.state.nh.us/elmi/pdfzip/econanalys/Look\\_forward/looking%20forward\\_economyinreview.pdf](http://www.nhes.state.nh.us/elmi/pdfzip/econanalys/Look_forward/looking%20forward_economyinreview.pdf)

### **NHLA: [Phase II Report on the Economic Value of NH's Surface Waters](#)**

Estimates of Select Economic Values of New Hampshire Lakes, Rivers, Streams and Ponds (June 2003)

### **NHLA: [Phase III Report on the Economic Value of NH's Surface Waters](#)**

Public Opinion Poll Results in the Study of Select Economic Values of New Hampshire Lakes, Rivers, Streams and Ponds (December 2004)

### **NHLA: [Phase IV Report on the Economic Value of NH's Surface Waters](#)**

The Economic Impact Of Potential Decline in New Hampshire Water Quality: The Link between Visitor Perceptions, Usage and Spending (May 2007)

# Ossipee Watershed Coalition Natural Resources Planning Guide

## Chapter VII - Global Impacts to Shared Resources

### I. Introduction to Global Impacts to Natural Resources

This chapter addresses the more global forces which increasingly affect the air, water, forest and wildlife habitat within the watershed. Here is a brief overview of some of these global forces, how they impact natural resources in NH and the watershed, and where to find more information.

The United States depends upon resources from very far away, relying upon soil, water, food, energy and other materials from foreign countries to support daily needs. This dependence not only disconnects us from local resources, but it also requires an overall greater use of the earth's natural resources. If the Ossipee Watershed could be seen as the long-term life support system for local residents – providing food, fiber, shelter, work, social opportunities, etc. – people might better steward our shared resources. “The more protected natural ecosystems are, the better prepared they’ll be to support needs locally.” (Environmental Planner Steve Whitman). Global issues are issues for the watershed communities now and in the not too distant future.

*The US has about 5% of the global population, consumes over 30% of the resources annually and produces over that amount of the world's carbon*

### A. Ecological Footprint

The “**ecological footprint**” is a resource management tool that measures how much land and water area a human population requires to produce the resources it consumes and to absorb its wastes. Population impact upon the environment is calculated through a system of accounting where the consumption of energy, biomass (food, fiber), building material, water and other resources are converted into a measure of land area called 'global hectares' (gha). Ecological footprinting is now widely used globally as an indicator of environmental sustainability. The average "earthshare" available to each human citizen is approximately 1.9 gha per capita. The US footprint per capita is 9.5, Switzerland is 4 gha, while China's is approx. 1.5 gha. World Wildlife Fund claims that the human footprint has exceeded the available supply of natural

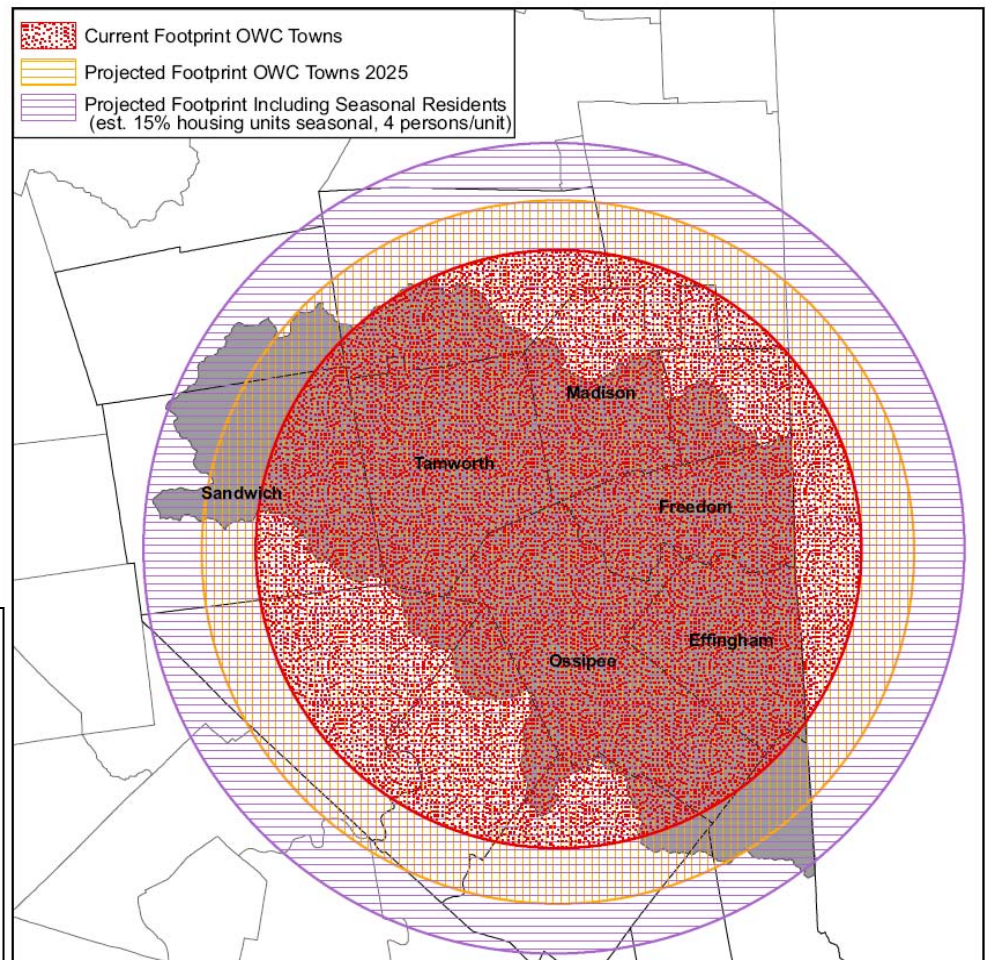

**Chapter VII, Figure 1,** This map illustrates the “footprint” of watershed residents on natural resources now and in the future. Calculations are based on 2004 base data from the Society for Protection of New Hampshire’s Forests and 2006 census data. Map created by Katie Callahan of New Hampshire Fish & Game.

resources of the planet by 25%. The map shows that the footprint of Ossipee Watershed residents already exceeds the boundaries of the watershed. With future population projections and seasonal residents increasing, the demand on resources is likely to be well outside the watershed's boundaries in the future.

**Additional Resources:**

- Ecological Footprint Quiz: <http://www.earthday.net/footprint/index.asp#>
- Footprint of Nations Report: <http://www.ecologicalfootprint.org/>
- Footprint Calculators: [http://www.ecobusinesslinks.com/ecological\\_footprint\\_calculator.htm](http://www.ecobusinesslinks.com/ecological_footprint_calculator.htm)
- Global Footprint Network: [http://www.footprintnetwork.org/gfn\\_sub.php?content=footprint\\_overview](http://www.footprintnetwork.org/gfn_sub.php?content=footprint_overview)
- Tips for Reducing Your Footprint: <http://www.sustainablecalgary.ca/projects/ecologicalfootprint.html>



**B. Climate Change**

Scientists are certain that human activities have changed the composition of the atmosphere and are influencing the Earth's climate. For over 200 years the burning of fossil fuels, such as coal and oil, and deforestation have caused the atmosphere concentrations of heat-trapping "greenhouse gases" to increase significantly. These gases prevent heat from escaping to space, much like glass greenhouse panels.

According to NOAA and NASA data, the Earth's average surface temperature has increased by about 1.2 to 1.4°F since 1900. The warmest global average temperatures on record have all occurred within the past 15 years, with the warmest two years being 1998 and 2005.

The greatest effects of climate change will be on regional air and water temperatures, precipitation patterns, storm intensity, and sea levels. Scientists have observed that some changes are already occurring, including: sea level rise, shrinking glaciers, changes in the range and distribution of plants and animals, trees blooming earlier, lengthening of growing seasons, ice on rivers and lakes freezing later and breaking up earlier, and permafrost thawing.

**Warming Trend Consequences**

	Indicator	Trends	Years Observed
	Days with Snow on the Ground*	16 fewer days	31
	Snowfall*	Decreased 10-60 inches	30
	River Ice Breakup*	11 days earlier	64
	Lake Winnepesaukee Ice Breakup*	8 days earlier	204
	Lilac Bloom Date*	4 days earlier	36
	Precipitation*	8% increase	100
	Growing Season Length*	8 days longer	101

\*New England 1New Hampshire

Source: Indicators of Climate Change in the Northeast, Markham and Wake 2005. Photo (middle): Courtesy of the National Weather Service

**Chapter VII, Figure 2 National Weather Service**

In the northeast United States, the average annual temperature has increased by 1.8°F over the last century. Of particular concern are changes to New England's winters. The average winter temperature has increased 4.4°F and the average snow cover season has decreased by more than 15 days over the last 30 years, affecting plants, animals and our way of life, from tourism to the economy and health care costs.

**Human Health.** A recent study found that storm frequency is projected to decrease in New England, which could increase air stagnation over much of the region. This stagnation may result in hazardous smog episodes that will increase in both severity and duration by mid-century if current pollution levels remain the same. In fact, studies for Boston and Portland already show increases in emergency room visits for respiratory and asthma incidents that correlate with bad air pollution days (specifically, ground-level ozone events). In addition to asthma and respiratory ailments, poor air quality is also harmful to New Hampshire residents with cardiovascular disease.



### New Hampshire Downhill Ski Areas

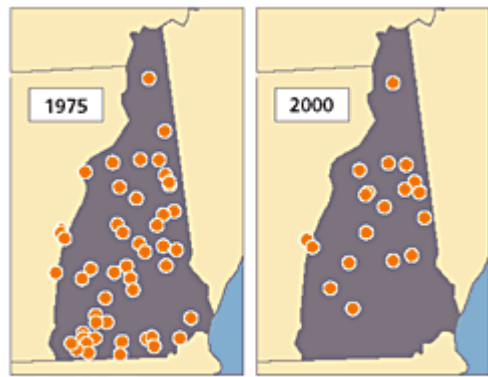

Hamilton et al., 2003

The effects of global warming are already being felt, as many ski areas (indicated by circles) have gone out of business.

Chapter VII, Figure 3

**Recreation & Economy.** This \$650 million industry is already suffering from shorter ski seasons and increased operating costs attributable to the warming of the past few decades. Since 1970 the number of New Hampshire ski areas dropped steeply, with many lower-elevation resorts in southern parts of the state going out of business. Today, ski areas depend upon snowmaking for more than 90 percent of their trails, increasing operating costs and the use of local resources. Other winter activities such as cross-country skiing, snowshoeing, and snowmobiling will see the earliest effects from global warming because these activities depend on natural snowfall, and do not have the option of artificial snowmaking.

**Plants & Forests.** Many plants have been observed to bloom earlier in the spring. For example, The New Hampshire state flower, the purple lilac, now blooms four days earlier. Projected

changes in forest species will change the forested landscape and character of the state. Trees such as sugar maples (*Acer saccharum*) that depend on prolonged cold temperatures are already being impacted by warming trends. In the past 20 years, the center of maple sugar production has shifted from the United States to Canada. Global climate models project a substantial northward shift in maple tree distribution. Such shifts in forest vegetation could cause lower elevations in New Hampshire to lose their brilliant fall foliage and resemble instead the brown autumns currently experienced in southern Pennsylvania.

**Wildlife.** According to the *New Hampshire Wildlife Action Plan (WAP)*, climate change will affect every species and habitat of conservation concern in New Hampshire, and has already been linked to local ecological changes including range shifts out of synchrony with seasonal habitat requirements (high altitude and coastal impacts are fairly well documented according to the WAP). Habitats with narrow temperature and water level regimes will likely be most impacted. Examples of such habitats include: alpine, high and low elevation spruce-fir forests, coastal islands, vernal pools, and aquatic habitats. Experts suggest that changing snow depths and high altitude seasonal timing may begin to have impacts during the next decade for animals such as the American marten, lynx and alpine butterflies. In the Ossipee Watershed, climate change may have the most noticeable impact on aquatic habitats. Scientists predict that the thermal habitat of New Hampshire's native fishes will likely decline substantially. Other concerns include the introduction and proliferation of invasive species, diseases, and pathogens that would be facilitated by warmer regional temperatures.

#### Additional Resources:

EPA Climate Change Website: <http://www.epa.gov/climatechange/basicinfo.html>

NH Carbon Coalition: <http://www.carboncoalition.org/>

NH Wildlife Action Plan:

[http://www.wildlife.state.nh.us/Wildlife/Wildlife\\_Plan/WAP\\_pieces/WAP\\_Chapter\\_4\\_risk\\_summaries.pdf](http://www.wildlife.state.nh.us/Wildlife/Wildlife_Plan/WAP_pieces/WAP_Chapter_4_risk_summaries.pdf)

Tips for Reducing Greenhouse Gas Emissions: <http://www.epa.gov/climatechange/wyced/index.html>

Union of Concerned Scientists Report: [http://www.ucsusa.org/global\\_warming/science/global-warming-in-new-hampshire.html](http://www.ucsusa.org/global_warming/science/global-warming-in-new-hampshire.html)

### C. Biodiversity & Extinction

The term **biodiversity** refers to the number and variety of organisms found within a geographic region and is often used as a measure of the health of biological systems. **Extinction** is the cessation of existence of a species or group of taxa, and reduces biodiversity. The main cause of species extinctions in

the past 1,000 years is habitat destruction from human activities. Overpopulation, deforestation, pollution, and climate change have all contributed to habitat destruction, extinctions and an overall loss of biodiversity. Another threat to biodiversity is the widespread introduction of exotic species by humans. When exotic species are introduced to ecosystems, the endemic species in that ecosystem that have not evolved to cope with the exotic species, may not survive. Similarly, when habitat is converted into pasture, cropland or is otherwise developed, plant and animal species are either forced to move, adapt or go extinct. Because an ecosystem decreases in stability as its species are made extinct, studies warn that the global ecosystem is destined for collapse if it is further reduced in complexity.

Human consumption of natural resources has raised the rate of extinction in recent decades. The normal background extinction rate is about 10 to 25 species per year; the current rate is likely to be at least several thousands of species per year and may actually be 10 times that high. There are currently 41,415 species on the World Conservation Union's (IUCN) Red List of Threatened Species that highlights species that are facing higher risk of global extinction. One in four mammals, one in eight birds, one third of all amphibians and 70% of the world's assessed plants on the 2007 IUCN Red List are in jeopardy.

On a more local scale, New Hampshire's mainly forested landscape supports a healthy biodiversity of plants and animals. As human activities change the landscape, however, that biodiversity is at risk. In 1998, the NH Ecological Reserves system project concluded:

*Though conservation lands comprise approximately 20% of the land area in NH, the current system of conservation lands in New Hampshire does not appear to provide comprehensive, long-term protection of biodiversity at the species, natural community, or landscape levels (NH Ecological Reserve System Project 1998a).*

Chapter V Section D of this guidebook covers the natural communities, plants and animals that contribute to the biodiversity found in the Ossipee Watershed. Watershed towns contain a variety of rare and exemplary natural communities, from kettlehole bogs to pitch pine forests. Rare plants, birds, reptiles, fish and insects, including many rare species of moths, are also found within the six towns (see link below for lists by town). Both global and local human activities threaten biodiversity within the Watershed, but with planning and protection of key areas that support rare species, rare types of natural communities, and high quality examples of common natural community types, biodiversity can be sustained.

Protecting natural community *systems* is the recommended scale at which to direct conservation targets in conservation planning, so applying a watershed-wide approach to planning can be an appropriate strategy for protecting biodiversity, as well as other natural resources. The NH Natural Heritage Bureau uses coarse and fine filter approaches to protecting biodiversity, by protecting exemplary natural communities, but also focusing on specific rare species that are not tied to specific natural community types. The goal of NH Heritage's coarse and fine-filter approaches is to inform management decisions by identifying those sites that have a relatively greater potential for maintaining the natural diversity within the state. Other organizations that work within the Ossipee Watershed to document, track and facilitate protection of rare plants, natural communities and animals include: The Nature Conservancy and NH Fish & Game Department's Nongame & Endangered Wildlife Program.

**Additional Resources:**

Biodiversity in NH: <http://www.dred.state.nh.us/divisions/forestandlands/bureaus/naturalheritage/biodiversity.htm>

Brochures for NH Natural Areas:

<http://www.dred.state.nh.us/divisions/forestandlands/bureaus/naturalheritage/guides.htm>

IUCN Red List of Threatened Species: <http://www.iucnredlist.org/>

NH Natural Heritage Bureau:

<http://www.dred.state.nh.us/divisions/forestandlands/bureaus/naturalheritage/index.htm>

NH Natural Heritage Bureau Statewide Map of NH's Biodiversity:

<http://www.dred.state.nh.us/divisions/forestandlands/bureaus/naturalheritage/documents/statemapJun07.pdf>

Rare Plants & Animals in NH by Town:

<http://www.dred.state.nh.us/divisions/forestandlands/bureaus/naturalheritage/documents/townlists.pdf>

Science Daily Extinction Article:

<http://www.sciencedaily.com/releases/2007/09/070912152659.htm>

#### D. Peak Oil

“Peak Oil” is the point at which the maximum global petroleum production rate is reached, as first expressed by Dr. M. King Hubbert in the 1950s. After this point, the rate of production will enter terminal decline. Oil is a finite resource, and therefore, is governed by basic laws which describe the depletion of any finite resource: Production starts at zero, production then rises to a peak which can never be surpassed. Once the peak has been passed, production declines until the resource is depleted. According to the Hubbert model, production will follow a roughly symmetrical bell-shaped curve, as shown below in the prediction model for oil and natural gas production around the world.

**Chapter VII, Figure 4** The General Depletion Picture of Oil and Natural Gas Liquids (2003 Base Case Scenario) This graph appeared in the May 2003 newsletter of Association for the Study of Peak Oil.

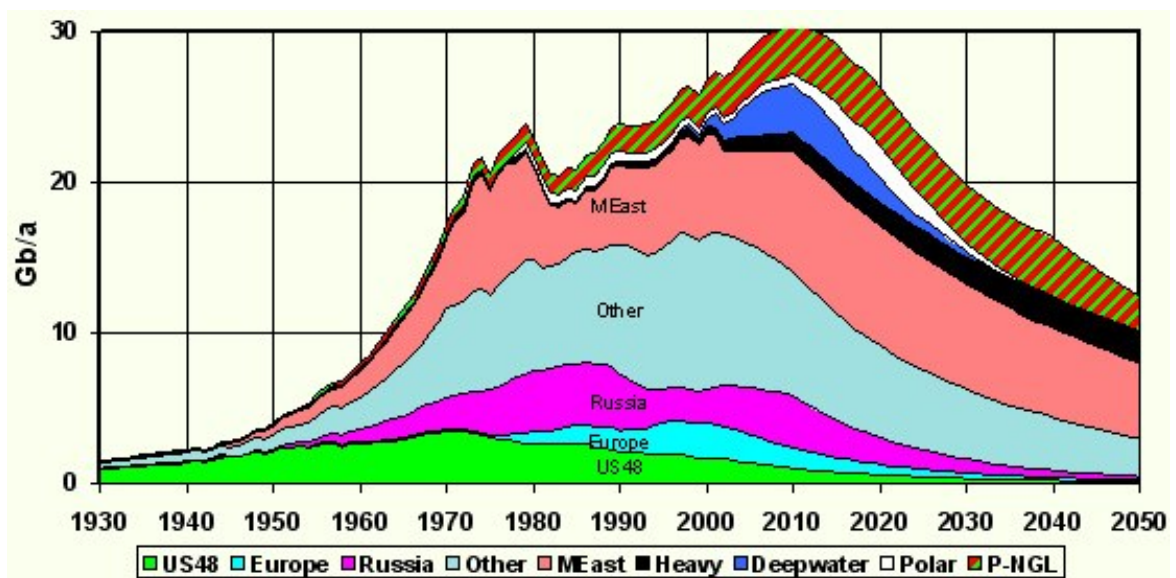

The United States relies heavily on oil and natural gas, which together provide 62 percent of the nation's energy and nearly 100 percent of its transportation fuels. By 2020, the Energy Information Administration expects we will need about 50 percent more natural gas and one-third more oil to meet demand. Over the next 20 years, U.S. oil production is expected to continue to decline, and demand for natural gas is expected to outpace domestic production, making our country increasingly dependent on foreign imports from Canada and other parts of the globe (The Bush Administration National Energy Policy Development (NEPD) report).

The majority of oil geologists have reached the conclusion that world oil consumption will peak soon. Studies place the peak year any time between 2006 and 2022, depending on optimism and assumptions. Experts believe that because of the high dependence of most modern industrial transport, agricultural and industrial systems on inexpensive oil, the post-peak production decline and possible resulting severe price increases will have negative implications for the global economy.

Solutions to the “peak oil” crisis include relying more on renewable energy sources and practicing energy conservation here at home. Renewable energy resources including wind, solar, and bioenergy are now affordable alternatives to the burning of fossil fuels. Recent studies suggest how energy alternatives and conservation efforts can benefit communities in New Hampshire:

- The federal renewable electricity standard requires utilities to generate a portion of their electricity from renewable sources can help create jobs and other in-state economic development while reducing air pollution and global warming emissions. If a 10 % standard passed in NH, consumers would save \$70 million on their electricity and natural gas bills by 2020.
- The U.S. Department of Energy (DOE) estimates that energy efficiency solutions are available now to cut national energy use 10 percent by 2010. For example, simply extending tax incentives for energy-efficient equipment and buildings and setting new efficiency standards for new equipment could reduce peak electricity demand 70,000 megawatts (MW) by 2020—eliminating the need to build 230 300-MW polluting power plants.
- A federal policy to increase the average fuel economy of cars, SUVs, and pickup trucks to 40 mpg over the next 10 years could allow Granite State consumers to cut their 2015 gasoline consumption by nearly 500,000 gallons every day, for a net savings of \$217 million at the gas pump. In addition, 700 new jobs would be created in New Hampshire by 2015.

#### **Additional Resources:**

Association for the Study of Peak Oil: <http://www.asponews.org/>

Hubbert Peak Oil Model: <http://www.hubbertpeak.com/summary.htm>

NEPD Report: <http://www.whitehouse.gov/energy/>

NH Carbon Coalition: <http://www.carboncoalition.org/education/index.php>

Planet For Life: <http://planetforlife.com/oilcrisis/oilpeak.html>

#### **E. Soil Degradation and Erosion**

Soil degradation is a global issue that refers to the depletion of soil and soil productivity due to natural and human processes. Soils serve many purposes, from producing our food to providing us with firewood and construction lumber, purifying the atmosphere, maintaining precipitation levels and slowing down erosion, and holding our drinking water. There are many types of soils, but soils that create productive forests or agricultural lands are fairly diverse in composition, made up of air, organic matter, water, mineral particles, nutrients, microorganisms, among other things. Soil structure declines when these different types of nutrients and organic matter and mineral particles are somehow drawn from the soil, leaving limited nutrients remaining in the soil.

Activities that affect soil productivity and structure include: wind erosion, water erosion, overgrazing, dryland salinity, soil acidification, the use of pesticides and other chemicals, irrigation salinity and waterlogging, the replacement of natural vegetation with pasture and the clearing of natural vegetation. When vegetation is removed from the soil, the soil is left to become exposed to the elements, leaving it bare and loosening the soil particles. The soil is then easily blown away, leaving poorer quality sub-soil to remain. This is a severe problem in parts of the world where arable land (land that can be used for growing crops) is scarce to begin with and human activities are placing higher demands on fragile, limited, or marginally productive soils.

Today, arable land covers 3% of the world's surface: of the earth's 148,000,000 km<sup>2</sup> (57 million square miles) of land, approximately 31,000,000 km<sup>2</sup> (12 million square miles) are arable. This arable land is currently being lost at the rate of over 100,000 km<sup>2</sup> (38,610 square miles) per year, mainly due to deforestation. Such deforestation continues primarily in tropical countries by commercial over-exploitation of tropical forest. At times, deforestation can be so extreme that it leads to desertification, or the total loss of arable land. It is estimated that one hectare of productive land is lost every 7.67 seconds.

Soils, soil types, and agriculture in the Ossipee Watershed are discussed in detail in Chapter V Sections F and G. Development of land with prime agricultural soils, water erosion, acidification, irresponsible forestry practices, the use of harmful chemicals and the clearing of natural vegetation for such things as farming, roads and residential and commercial developments are among the threats to soil integrity and long term viability of arable land in the Ossipee Watershed.

### **Additional Resources**

American Farmland Trust Arable Land Demonstration: <http://www.farmland.org/Flash/appleEarth.html>

Soil Erosion & Land Degradation: [http://library.thinkquest.org/03oct/00128/en/links/soil\\_ero\\_degrad.htm](http://library.thinkquest.org/03oct/00128/en/links/soil_ero_degrad.htm)

Arable Land Facts & Definition: <http://en.wikipedia.org/wiki/Arable%5Fland>

World Clocks (counters for world population & arable land): <http://tranquileye.com/clock/#productive>

## **II. Global & Local Economies**

As discussed above and in the Agriculture chapter (V.G.) and the Economy and Tourism chapter (VI), global trade and economics work to undermine local and regional economies. "Relocalization" as one way of assessing what can be produced or created in the watershed/region, and how to increase economic activity locally rather than exporting and importing with little consideration of the local and global environmental impacts. All of the trends in this section point to the need to reduce our impacts, and sustainably use resources that are closer to home

This chapter offers several areas that are global in scale, yet would benefit from our direct actions and behavior within the Ossipee Watershed. Citizens and municipal officials can make a difference locally by understanding these issues, forming committees to take action, getting the support of the citizenry, and supporting non-profit and public efforts to resolve these issues (See Recommendations Chapter).

A 'tipping point' is reach when enough people start to think and act, to change behavior such that the majority then follows. The keys are the desire to change (or the fear of outcomes from not changing), education, and organizations taking the lead. Citizens in this region are well suited to take on this challenge since they are so close to, and dependent on, the high-value natural resources in the Ossipee Watershed.

### **Additional Resources**

<http://www.relocalize.net/about/relocalization>

[www.boulderrelocalization.org/](http://www.boulderrelocalization.org/)

<http://www.tclocal.org/>

# Ossipee Watershed Coalition

## Natural Resources Planning Guide

### Chapter VIII – Natural Resource Planning Recommendations

#### I. Introduction

This Guide provides information and resources to assist the six towns in the Ossipee Watershed in implementing strategies to minimize negative impacts to existing and future drinking water supplies and natural resources. This is done while taking into account current and future growth trends, economic needs and associated land use.

Although the natural resource information in this Guide is presented as separate topic areas, there are many links between resources and the potential threats to them. For example, population growth and land use changes which result may lead to reductions in recharge. Therefore, even though each section discusses a natural resource individually and provides specific recommendations, due to natural resource interconnections, many protection measures overlap and can be undertaken together to adequately ensure the sustainability of all natural resources. Furthermore, since our resources know no political boundaries, complementary implementation across the watershed can be the most comprehensive resource protection of all. It is the goal of the Ossipee Watershed Coalition to help facilitate such watershed-wide protection of natural resources.

#### II. Section Overview

The following broad recommendations were developed based on information gathered from the six communities in the Ossipee Watershed. The recommendations explore potential options for the long-term protection of all natural resources, including the quality and quantity of drinking water supplied by the stratified drift aquifer. Each recommendation is followed by an overview of the potential benefits of implementing the recommendation as well as the challenges towns might face, either individually or collectively, in working to implement the recommendation. This information is designed to assist the six towns in selecting approaches to natural resource protection that can be town-specific and could be undertaken watershed-wide.

#### III. Recommendations are shown as a list then discussed individually.

*Note: These recommendations are not listed in order of priority*

Recommendation #1: Update Master Plans with a natural resources section.

Recommendation #2: Adopt aquifer protection ordinances for all watershed towns.

Recommendation #3: Strengthen site plan review and subdivision regulations.

Recommendation #4: Protect land for priority natural resources.

Recommendation #5: Protect shoreland habitats.

Recommendation #6: Provide shared natural resource education and outreach.

Recommendation #7: Plan land use regulations to prevent groundwater contamination.

Recommendation #8: Update the Potential Contamination Source (PCS) Inventory.

Recommendation #9: Perform BMP audits and provide education on PSCs.

Recommendation #10: Devise emergency plan for hazardous material spills.

Recommendation #11: Ensure BMPs for road salting and salt storage.

Recommendation #12: Ensure BMPs for commercial and industrial uses.

Recommendation #13: Provide education and outreach program for gravel pit operations.

Recommendation #14: Utilize geology maps and studies as town planning tools.

Recommendation #15: Develop cooperative GIS mapping resource for watershed towns.

Recommendation #16: The Ossipee Watershed Coalition should continue to be active.

Recommendation #17: The Ossipee Watershed Coalition should meet annually to review progress in implementing priority recommendations and to monitor project results.

---

**Recommendation #1: Ensure Master Plans of the six towns contain language to support current and potential ordinances and regulations that protect natural resources. The Master Plan should contain a natural resources section and as a minimum a water resource plan.**

Town Master Plans are adopted and amended by the Planning Board after a public hearing as required by RSA 675:6. Planning Boards are strongly encouraged to involve citizens in the process of reviewing and amending the Master Plan. Resources are available to help Planning Boards gather information about their towns, survey their citizens and write sections and chapters of the Master Plan. These include the Lakes Region Planning Commission, the North Country Council, the NH Office of Energy and Planning and private planning consultants.

**Benefits of Implementing the Recommendation:**

- The Master Plan should contain supporting information to give legal standing to the implementation of ordinances and other regulations by the Planning Board. This is very important should ordinances/regulations be challenged in court. Including this information in the Master Plan is critical to the implementation of a number of Guide recommendations.
- The Master Plan can assist in community education about the value of natural resources and the impact of existing and potential future conditions on those resources. Education is critical in gaining community support for the implementation of Guide recommendations.

The six towns should also consider including within their Master Plans indication of the shared nature of watershed-wide natural resources, such as the aquifer, and the need for a collaborative approach towards their protection. Reference to this Guide, which was compiled with participation from all six communities, could support future collaborative efforts.

*Note: Towns in the process of updating their Master Plan should work to ensure the Master Plan supports priority natural resource protection efforts.*

**Recommendation #2: Adopt aquifer protection ordinances in all watershed towns.**

There are two approaches that could be taken to achieve this recommendation: either adopt one set of standards, consistent between each town, or six different ordinances to increase the level of protection in all six communities.

**Benefits of Implementing the Recommendation:**

***Approach One: One aquifer protection ordinance consistent between all six towns.***

- If each town could come to a consensus on all aspects of an aquifer protection ordinance, then the same requirements would be consistent across the entire aquifer. Benefits of this approach include

consistent levels of protection of water quality for existing and potential future water supplies and opportunities for collaborating on public education and outreach regarding the specific content of the ordinance.

***Approach Two: Individually designed aquifer protection ordinances for each town.***

- Since the aquifer is presently protected at varying levels in the six communities, this approach would allow each town to tailor the ordinance to meet individual community needs, drawing from a set of concepts and standards developed for the whole aquifer. For example, one may want to refine its existing ordinance to make it more effective, while another may want to expand on its existing language to incorporate additional levels of protection, while a third may want to develop its initial aquifer protection ordinance. All six towns would be provided with the same information and resources from which to develop their specific approaches.
- Towns choosing to individually design their aquifer protection ordinance should as a minimum have the same level of protection as generally adopted by the other towns. Ordinances designed for specific town resources should have references within the Master Plan.

**Challenges to Implementing the Recommendation:**

In crafting ordinances for either approach, many factors must be considered to achieve a balance between zoning restrictions, existing and future land uses, economic development, transportation corridors, and the protection of the quality and quantity of drinking water for the six communities in the present and into the future. It is very important to take into account the many diverse needs of each community when developing the aquifer protection ordinances. Information contained in this Guide, as well as the knowledge of those involved with the Ossipee Watershed Coalition, town boards, town officials, and key community stakeholders, are all very helpful in the development of draft ordinances. In either approach, public outreach and education are critical as zoning ordinances must be brought before Town Meeting for approval by the local legislative body, a vote by the townspeople.

**Recommendation #3: Strengthen site plan review and subdivision regulations in each town to ensure these regulations reflect current scientific and engineering knowledge and BMPs and minimize any potential negative impacts to natural resources.**

**Benefits of Implementing the Recommendation:**

- Strengthening and incorporating natural resource components into the site plan review and subdivision regulations, in a manner that supports the protection of natural resources will increase the overall long-term protection of these resources.
- In site plan review and subdivision regulations, towns can require certain information as part of the application process. By requiring the identification and location of sensitive natural resources, and the mitigation of impacts on these to the greatest extent possible, the quality and quantity of these resources can be further protected.
- Since such a large percentage of the direct recharge area is zoned commercial and/or industrial, site plan review regulations are an important planning tool for the six towns.



- Requiring compliance and disallowing waivers of your site plan or subdivision regulations that directly impact sensitive natural resources will help the ever-changing make-up of planning and zoning boards to remain consistent in their efforts to protect these resources.
- Towns cannot adopt site plan review regulations until after they have adopted an initial zoning ordinance. See RSA 674:43, I.

### **Challenges to Implementing the Recommendation:**

With any natural resource protection overlay zone, a balanced approach is critical when strengthening site plan review and subdivision regulations. The requirements should be comprehensive and support the protection of sensitive natural resources without being so restrictive or costly that economic development and/or other important community needs are hindered.

*Note: Although revisions to site plan review and subdivision regulations do not necessarily need to follow revisions to the zoning ordinance, this order of revision will make it easier for the communities to ensure that regulations are consistent with and do not conflict with zoning ordinances.*

### **Recommendation #4: Protect land in areas of sensitive natural resources to protect both the existing and potential future value of these resources.**

#### **Benefits of Implementing the Recommendation:**

- Permanent land protection, either through land purchases or conservation easements, will help ensure no detrimental impacts from potential contamination sources will take place in these areas.
- The creation of public open space and protection of land over the aquifer can provide recreational opportunities, increase wildlife habitat, and contribute to the rural character of the six communities.
- Innovative techniques should be explored for increasing the levels of protection around sensitive natural resources, such as shifting the focus for development potential to areas outside of these zones, thereby allowing higher density development in less sensitive areas and reducing development pressure on sensitive resources.
- Preservation of land that is contiguous across town boundaries creates an opportunity for public education about the importance of shared resources.
- Successful grant applications to programs such as the Water Supply Land Grant Program and the Land and Community Heritage Investment Program (LCHIP) for protection of land in Wellhead Protection Areas and direct aquifer recharge areas would bring additional resources to the six communities and benefit present and potential drinking water supplies.
- Towns or public drinking water suppliers may choose to have their wellheads reclassified through New Hampshire DES Drinking Water Source Protection Program to further restrict certain Potentially Contaminating Sources (PCSs) from being situated in the wellhead area and allow the enforcement of BMPs for all PCSs within the wellhead by the local entity.

- Towns may want to look closely at the land identified in the Favorable Gravel Well Analysis that has a higher potential for serving as a public water supply. On the ground site visits to these areas and other hydrogeologic research would assist in determining which sites might be suitable for land protection efforts to ensure safe future water supplies.

*Note: Combined Water Supply Land Grants and LCHIP applications resulted in 75% funding of projects elsewhere in NH. By leveraging funds, the towns could permanently protect drinking water sources and obtain public open space at lower cost to each town.*

**Recommendation #5: Ensure that provisions for the protection of shoreland habitats match or exceed those in force by state law (Comprehensive Shoreland Protection Act) and that such provisions are effectively enforced.**

**Benefits of Implementing the Recommendation:**

- The Comprehensive Shoreland Protection Act (CSPA) was crafted in universal recognition of the importance of maintaining an undisturbed, protective vegetative buffer around major water bodies – lakes, ponds, rivers, and streams. Such a riparian zone assists in blocking surface and deeper water access by hazardous chemicals, excessive nutrients, and rapid stormwater flow. However, smaller, headwater streams are not currently included under this protection, yet they are common in the Ossipee watershed and ultimately deposit their contents in downstream water bodies. Smaller streams need protection.
- Staff shortage at the Department of Environmental Services limits enforcement capability of CSPA at the state level. However, within the CSPA regulations it states that "municipalities may elect to enforce the provisions of the CSPA by issuing cease and desist orders, and by seeking injunctive relief or civil penalties as provided in [the CSPA]." Towns may incorporate more stringent standards in local zoning ordinances. In these circumstances, the town's officers can enforce their own or CSPA regulations, and in either case, locally served penalties for infractions can be available to the town and will make compliance within the town more persuasive.

**Challenges to Implementing the Recommendation:**

In an area experiencing relatively rapid growth and development, enforcement of existing codes can be daunting. With shoreland protection provisions already a part of state law, enforcement of these matters could reasonably be seen as a state responsibility. Under current state funding, this is impractical. If the job is going to be done in the near term, it appears that towns will need to become more active in doing it. It does require local code officers to become conversant with and willing to apply another set of protective provisions. Ultimately, the goal is to protect critical shared resources from the short-term, damaging actions of a few that may have long-term consequences for the health, aesthetics, and economy of the region.

**Recommendation #6: Provide citizen education to increase awareness about shared natural resources, potential impacts to resources within each community and methods for reducing individual impacts to enhance natural resource protection.**

**Benefits of Implementing the Recommendation:**

- To raise community awareness about natural resource protection, education and outreach is essential. The members of each community should be given the opportunity to learn about the importance of shared natural resources. By building a foundation of knowledge throughout the six towns, citizens will be better informed when the time comes to make important community decisions that impact the aquifer and other natural resources. The education and outreach program should stress the importance of natural resources to every aspect of community: economics, quality of life, health, ecological processes, etc.
- Providing actual historical natural resource maps and data within communities demonstrating the level and quality of the resources within each town as compared to the other towns in the watershed can enhance awareness of common efforts to protect our shared natural resources.

***Re: Encourage Low Impact Development***

- Communities can educate developers, residents and businesses to utilize low-impact development (LID) techniques. LID is an approach to site development and design that takes into consideration stormwater infiltration and the natural hydrology of a watershed to protect water quality, prevent flooding, increase groundwater recharge rates, and prevent negative impacts on wildlife and wildlife habitat.
- Providing targeted education to residents, about household hazardous materials, the use of chemical fertilizers, and septic system maintenance, for example, will raise awareness about how we all play a part in impacting and can all play a role in protecting our shared natural resources.

***Re: Household Hazardous Materials***

- Community members need to know that pouring common household chemicals such as paint thinner, cleaning products, and used motor oil on the ground or down the drain has the potential to contaminate groundwater. By educating community members about these threats to groundwater, smaller amounts of household hazardous materials are improperly disposed.
- Continued participation in Household Hazardous Waste Collection efforts will help ensure that these household hazardous materials are disposed of properly and no longer pose a threat to groundwater supplies.

***Re: Use of Chemical Fertilizers***

- Excessive amounts of chemical fertilizers used on residential lawns may leach chemicals and nutrients into stormwater runoff and have the potential to impact ground and surface water.
- Proper use of fertilizers in adequate but not excessive quantities, and the use of organic versus chemical fertilizers will reduce negative impacts to ground and surface waters.

***Re: Septic System Maintenance***

- While septic systems that are designed, installed, and maintained properly do not pose a threat to groundwater, poorly functioning and/or failing septic systems do have the potential to contaminate ground and surface water.
- Educating community members about the importance of septic system maintenance can avert potential groundwater contamination.
- Towns may choose to implement “Septic Ordinances” (that can be implemented by selectmen) to effectively enforce BMPs on homeowners and businesses, such as regular pumping of septic tanks within select recharge or watershed areas.

**Recommendation #7: Ensure land use regulations are in place and followed to protect groundwater and surface water resources from hazardous materials contamination.**

**Benefits of Implementing the Recommendation:**

- The threat of contamination of groundwater and surface water could be minimized by prohibiting land uses in sensitive aquifer recharge areas that involve the use of hazardous substances requiring permitted uses to implement BMPs for handling hazardous materials in accordance with state law.
- A local official such as the Building Inspector or Health Officer could be given the responsibility to work with the Department of Environmental Services to insure that certain types of businesses are following proper hazardous material handling practices and to educate these business owners.
- If education and multiple requests don't lead to cooperation, enforcement action can be taken by the State official.

**Challenges to Implementing the Recommendation:**

Public education is needed on the types of commercial and industrial uses that either should not be permitted in sensitive aquifer recharge areas or that should require the following of BMPs in the handling of potential pollutants. Zoning ordinances regulating types of land uses in sensitive areas would need to be passed by the local legislative body.

**Recommendation #8: Update the Potential Contamination Source (PCS) Inventory once every three years.**

A copy of the updated map should be inserted into this resource document and updated information should be submitted to NHDES. By maintaining an accurate and up to-date PCS Inventory for the watershed area, the six communities will have a thorough understanding of potential contamination threats to natural resources, which can serve as an important tool in the planning process.

**Benefits of Implementing the Recommendation:**

- There will be a current understanding of PCSs in the watershed and allow municipal officials to review and respond to new situations that may arise.

- It would remind municipal officials of PCS issues frequently enough to inform new officials of the extent and importance of this issue.

### **Challenges of Implementing the Recommendation:**

Encouraging municipal officials to schedule this review on a regular basis may get interference from the day-to-day issues that they always face. Implementing this would mean that municipal officials would have to place this action on a schedule three years out. This process could be greatly facilitated if the PCSs were examined every three years for the six towns by one body (e.g., Ossipee Watershed Coalition/GMCG/conservation commissions) and then this information given to the municipal officials (see Recommendation #9).

**Recommendation #9: The Ossipee Watershed Coalition should consider establishing a subcommittee of volunteers from the six towns to perform BMP audits and educate officials and interested parties on PSCs within the watershed.**

### **Benefits of Implementing the Recommendation:**

- It is the purpose of this Guide to inform municipal officials of the importance of BMPs necessary to protect all natural resources; it is unlikely, however, that many know whether BMPs are being followed, perhaps with the exception of the Road Agent. Conducting audits to update municipal officials would significantly improve awareness and the probability of corrective action taking place.

### **Challenges of Implementing the Recommendation:**

The challenge would be ensuring that the Ossipee Watershed Coalition continues to operate as an organized body and actively takes on this recommendation. Since many BMPs happen on private land or at private facilities, a challenge will be getting private owners to agree to such audits. An education program will be critical toward this end, as will the cooperative and sensitive approach by the Coalition. Cooperative support from municipal officials and, where appropriate, State officials, will be important to the success of such an effort.

**Recommendation #10: Work with town water supply districts and departments and local fire departments to ensure that an emergency plan exists to protect groundwater and surface waters in the event of a hazardous material spill on the road network in the direct aquifer recharge area in close proximity to the water supply wells, or close to wetlands, rivers and lakes.**

### **Benefits of Implementing the Recommendation:**

- In the event of a hazardous material spill over a water resource area, an emergency plan could facilitate a rapid response in assembling a cleanup by trained professionals. This would minimize the chances that a well, aquifer, rivers or streams would be contaminated.
- One or more of the 6 towns could apply for a grant to obtain Hazardous Materials training and sufficient spill recovery equipment necessary to act as first responders to hazardous spills within the watershed under a mutual aid agreement.

### **Challenges to Implementing the Recommendation:**

All existing emergency response mechanisms would need to be researched to determine whether or not responses would be quick enough and of an appropriate nature to ensure protection of water resources in the event of an accidental spill. Additional response mechanisms specific to the protection of groundwater would need to be coordinated with existing systems. Personnel and equipment costs would need to be researched.

**Recommendation #11: Ensure that current BMPs are followed for road salting and salt storage in the direct aquifer recharge area, including working with NHDOT to identify methods for reducing salt use on state roads in the direct aquifer recharge area.**

### **Benefits of Implementing the Recommendation:**

- Proper siting of salt storage facilities, on flat sites away from surface water, with an impervious surface underlying the facility, and a cover over the salt to protect the salt from runoff, should minimize potential ground and surface water impacts.
- In addition, the aquifer can receive additional protection from road salt impacts if the communities and NHDOT follow current BMPs during road salt application in the vicinity of public water supplies as well as in the direct aquifer recharge area. In applying road salt, location, quantity, and frequency are important factors in minimizing potential impacts.

### **Challenges to Implementing the Recommendation:**

Although some practices, such as applying the proper amount of salt for given road conditions, are not as costly, other methods, such as utilizing alternatives to salt or purchasing new equipment, could add a substantial cost. Each community needs to ensure that roads are safe for travel, while also minimizing ground and surface water impacts, which is a difficult task during extreme weather events and long winters. If NHDOT and towns were willing to explore reductions in road salt use and the implementation of BMPs to protect groundwater quality in critical areas, a coordinated approach could be taken to assure that those applying road salt have adequate information to implement this Recommendation while at the same time keeping the roads clear enough for safe passage of vehicles. Road signage indicating reductions in the use of salt might also be an important component of implementation.

**Recommendation #12: Develop voluntary BMPs for commercial and industrial uses, suited to the needs of the six communities, to minimize degradation of sensitive natural resources, including surface and ground water.**

### **Benefits of Implementing the Recommendation:**

- It is important that BMPs be followed to minimize pollution from stormwater runoff and encourage recharge to the aquifer. These BMPs may be incorporated as requirements into the aquifer protection overlay zone and site plan review and subdivision regulations for new developments by reference, and used as an educational tool for uses that are already grandfathered.

- Business owners and operators should be involved in the process of developing of BMPs. This type of cooperative effort ensures that many perspectives are incorporated into the development process, which contributes to the successful implementation of this Recommendation.
- BMPs manuals already exist for issues such as stormwater management. A review of these materials will determine if they are appropriate tools, or whether more specific educational materials should be developed for the protection of the aquifer in the six towns. One goal might be to incorporate the most desirable aspects of existing techniques along with design guidelines that outline the specific elements most important to the six towns and the protection of their drinking water supply presently and into the future.

### **Challenges to Implementing the Recommendation:**

If specific materials are desired, the towns will need to explore additional funding sources to design and produce these materials in sufficient quantities and of such quality that they can be distributed throughout the six communities. Toward this end, the towns will need to investigate what BMP guideline materials are already available from State agencies and other organizations. These efforts will have to be closely coordinated with public education efforts to ensure success. Private business and industry environmental protection activities are in many cases the responsibility of the State, so coordination with NHDES and other agencies will be necessary to minimize redundancy and maximize cooperation.

### **Recommendation #13: Develop an education and outreach program for gravel pits.**

The communities' concern for maintaining safe drinking water supplies and a healthy aquifer resource can be explained to reinforce the importance of following BMPs, and to help develop/improve earth removal regulations for gravel pits not providing material for state roads. RSA Chapter 155-E gives Planning Boards authority to regulate gravel pit permits and allows Planning Boards to adopt local gravel pit regulations that complement state law. This education and outreach program should include planning board members in the six towns.

### **Benefits of Implementing the Recommendation:**

- Removal of sand and gravel in the direct aquifer recharge area increases the potential for groundwater contamination if BMPs are not followed.
- By reducing the potential for pollution from equipment operation, maintenance and washing, maintaining unexcavated material above the seasonal high water table, and ensuring proper site reclamation, the potential for groundwater contamination will be minimized.

### **Challenges to Implementing this Recommendation:**

Major sand and gravel mining operations are, for the most part, private facilities. The challenge is to offer educational materials and subsequent discussions in a way that facility owners can be engaged in a positive way. Involvement of the NHDES may be necessary. Management activities at any town sand and gravel pit may be more directly influenced by an educational program, but a positive and cooperative approach, in concert with appropriate town officials is recommended.

**Recommendation #14: The Ossipee Watershed Coalition and towns should obtain copies of revised maps and updated studies of hydrogeologic and groundwater characteristics, such as surficial geology maps from USGS, as they become available, and incorporate them into this Guide as additional planning tools.**

The towns may also consider carrying out additional hydrogeologic studies to gain a more complete understanding of groundwater movement and characteristics.

**Benefits of Implementing the Recommendation:**

- The federal and State USGS continue to update their knowledge of the geology of New Hampshire. Monitoring any updates could improve the understanding about resources in the Ossipee watershed. Additionally, non-profit groups and others occasionally undertake special studies that help improve our knowledge.
- Our knowledge of where and how groundwater moves is an on-going need and towns could make sure that the USGS and others understand that more data and analysis will help towns better understand how to best protect critical water resources. The same goes for other natural resources influenced by soil and subsurface conditions.

**Challenges of Implementing the Recommendation:**

Funding is always a challenge to gathering scientific data. However, if towns make it known to the State and other groups that this information is important, this can serve as the basis for support of their desired funding. Requests and letters of support would need to be generated, but this is a small effort compared to the potential benefit.

**Recommendation #15: Towns should pool resources and develop a cooperative GIS mapping resource for the six towns to share.**

Municipal officials and planners could then use this shared resource to evaluate planning, development and resource use issues, make decisions based on most current data, and look at overlapping resources, a key attribute of the GIS tool.

**Benefits of Implementing the Recommendation:**

- Having a tool readily available to map different resources and look at proposed projects within the towns, on an interactive and near real-time basis, could significantly improve the level of understanding of a project's potential impacts and how to mitigate or minimize impacts, if any seem likely.
- It could mean a significantly improved understanding of our natural resources within the watershed and how resources are influenced across town borders. This could help a town better coordinate with a neighboring town as to common goals and how to deal with projects on town borders.



- This resource would give the towns the ability to do interactive spatial analysis of their resources and proposed projects.
- Leveraging cooperative funding allows a common resource perhaps too expensive for one to be shared with all without each town bearing the entire cost burden themselves. If this resource is available through an existing source, then, only support for additional labor costs might be needed.

### **Challenges of Implementing the Recommendation:**

Again, funding is the key challenge here. Citizens are very sensitive to increased taxes, so any proposed budget to support common GIS resources would have to be well justified and efficiently costed. Another challenge is managing the resource if funded, and making sure there is equality in availability of use or an adjustable cost scale if some towns utilize the resource more frequently.

**Recommendation #16: The Ossipee Watershed Coalition should continue outreach to all stakeholders in the six towns that share a common aquifer and continue to meet regularly to share town initiatives, information and discuss opportunities for collaboration related to all natural resources in the watershed.**

### **Benefits of Implementing the Recommendation:**

- A key theme to this Guide and the rationale for the Coalition is to protect shared resources. This recommendation addresses this important concept.
- There are efficiencies of scale if towns can research and share common information via one resource- the Coalition offers that opportunity.

### **Challenges of Implementing the Recommendation:**

The major challenge to this recommendation is ensuring that the Coalition stays organized and is supported by active representatives from each town.

**Recommendation #17: The Ossipee Watershed Coalition should meet annually to review progress in implementing priority recommendations and to monitor project results.**

A summary chart will be presented annually in Appendix A. at the end of this document and it will show the status of ordinances in each town to assist the OWC in this monitoring process. Once recommendations identified as priorities have been implemented, the OWC should reprioritize the remaining recommendations and explore opportunities for implementation.

### **Benefits of Implementing the Recommendation:**

- In order for the towns to really benefit from this Guide, regular (at least annual) updates and progress reports will be necessary to ensure implementation. A matrix ‘scorecard’ has been prepared by the Coalition and will be a tool to help participating towns understand the status of their ordinances.

- With regular support from an organization like the Coalition it is much more likely that a coordinated effort will take place; and a report card can help municipal officials track progress toward protecting shared resources.

### **Challenges of Implementing the Recommendation:**

As above, the ability of the Coalition to stay active and maintain interested parties dedicated to protecting the shared natural resources will determine the effectiveness of the stated mission. Also, having the support of municipal and State officials and other non-profit groups will be important to keep these initiatives viable.

<sup>1</sup> Several Recommendations were adapted from the Lakes Region Planning Commission 2003 report “*Protecting Shared Drinking Water Sources; A Collaborative Initiative of the towns of Belmont, Northfield, and Tilton.*” Their insight and permission is gratefully acknowledged.

# Natural Resource Planning Guide

## HOW GIS MAPS WORK

### WHAT IS A GIS MAP?

It is a map created from a data base of over 50 types of natural and cultural data from towns as well as statewide sources. This NH specific database is called GRANIT (Geographically Referenced Analysis and Information Transfer) The maps can be customized in various ways and may contain the following:

**Base Resources:** Town boundaries; Conservation lands; Streams; Surface waters; wetlands; Roads, trails, railroads, utility lines; contour lines

**Water Resources:** Source water protection areas; Source water wells; Stratified drift aquifers; Potentially favorable gravel well areas; Contamination areas/points; Riparian zones

**Soils:** Prime agricultural soils; Hydric soils; Important forest soils

**Unfragmented Lands:** Depicts large blocks of undeveloped land areas

**Natural Resource Co-occurrence:** Depicts area of overlapping critical natural resources

### HOW IS A GIS MAP CREATED?

The computer tool used to pull information out of the database is called **GIS** (Geographic Information System). It has the ability to display multiple layers of information (such as roads, parcels, and water areas) overlaid upon one another.

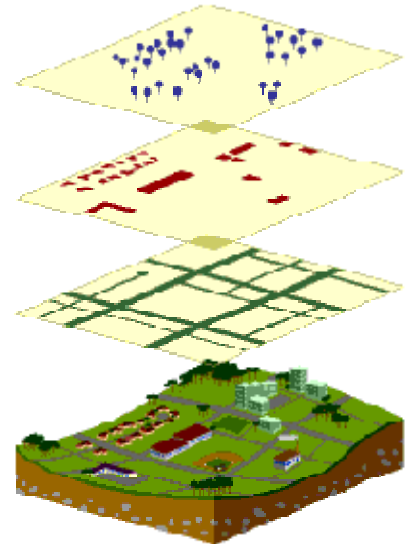

### Example of GIS multi-layering →

### WHO USES GIS MAPS?

Town and local government officials, conservationists and others who want to achieve informed decision-making in their efforts to:

- Determine the current or future, use, needs or protection of natural or man-made resources;
- Provide scientific basis for decision making about both regulatory and non-regulatory approaches to preserve natural resources
- Use GIS maps to show the location and extent of existing resources, such as farmlands, surface and ground waters, and related features.

### HOW CAN YOU USE THE GIS MAPS?

1. **Determine your need:** Using the **Example Uses of GIS Maps** list (below), or the description of maps (above), or your own needs/ideas, determine what resources you want to track/review
2. **Find the right map:** Using the description of maps above find the map or maps which contain the resource (natural or manmade) which you want to track/review.

**EXAMPLE USES OF GIS MAPS:** For general PLANNING, EDUCATION, or DOCUMENTATION:, the maps can display:

- ☛ Which areas in the community have the most important resource values, and where specific resource combinations occur
- ☛ What are the threats to the continued availability of important natural resources?
- ☛ Are there natural resources identified that are important to other communities or the region?
- ☛ Document current conditions so changes over time can be assessed
- ☛ Educate local officials and the public about natural resources
- ☛ Initiate and support land protection efforts
- ☛ Provide a basis for land use planning efforts
- ☛ Update Towns' master plans

**ADDITIONAL USES OF GIS MAPS:**

**Education:** GIS maps can be used by conservation commissions to guide conservation planning, planning boards to review land use proposals requiring regulatory oversight, selectmen, citizens, conservation groups and land trusts to guide land conservation plans for the region, and regional planning commissions.

**Master Plan Updates:** A Master Plan is authorized in RSA 674 as the policy document that represents, in text and maps, the current conditions in a community and the community's vision for future land use. GIS maps can be included in sections on current natural conditions, and guide the preservation, conservation, and use of natural resources. The statute calls for the Master Plan to be reviewed and revised as necessary at intervals not to exceed 5 years.

**Regulatory Techniques for Protecting Important Natural Resources:** Regulatory controls are a traditional component of community government, and are relied on to control land use, and provide protection for open space, the environment, and community character. GIS maps can be used to guide **zoning regulations** towns use to encourage appropriate and wise land use in growing and evolving communities. Towns can add **Overlay districts** such as groundwater protection district, mountain conservation district, historic district, forestry district, district for Species of Concern, district for steep slopes, agricultural district, telecommunications district, etc. NRI maps can be used to identify potential **greenbelts, buffers, and corridors**, such as shore land buffers, recreational trail buffers, buffers for agricultural operations, buffers for commercial and industrial areas, forestry buffers, and wildlife corridors. A town's conservation commission, or planning board may undertake to designate, map and document **prime wetlands** lying within its boundaries, which are to be preserved because their size, unspoiled character, fragile condition or other relevant factors, make them of substantial significance.

**Non-Regulatory Techniques for Protecting Important Natural Resources:** Non-regulatory approaches to land use control are non-confrontational, and can be proactive rather than reactive. A Conservation Plan, based on information obtained through using the Natural Resource Guide and GIS maps, reflects the values of the community and can be a tool towns can use to determine the areas in need of conservation and which are appropriate for desired development. Protection can be in the form of **Acquisition** of full ownership, **Conservation Easements**, or **Management Agreements** such as Right of Way for trails, wildlife corridors, and buffers between uses. **Current Use** is a preferential tax program that encourages landowners to keep open space undeveloped.

**ERRORS:**

Maps represent the most current data available. Please report any errors found in data or presentation to Green Mountain Conservation Group, P.O. Box 95, South Effingham, NH 03882.

**Ossipee Watershed Coalition  
Natural Resource Planning Guide  
Appendix A: Annual Updates**

To ensure the sustained protection of the Ossipee Watershed, planning and decision making by the included municipalities and their citizens needs to be based on accurate and up-to-date information regarding our common resources. Accordingly, it is the intent of the Ossipee Watershed Coalition to treat this Guide as an evolving document by continually enriching it through the addition of new data regarding our ever-changing human and natural surroundings. While annual additions will be integrated into the preceding chapters as appropriate, they will also be summarized in this chapter as annual updates.

In addition, it will be important for municipal officials to be able to view their own town's deliberations and actions in a broader context of the watershed as a whole. To that end, the Ossipee Watershed Coalition plans to include in this chapter a helpful table to display progress being made towards the enactment of common ordinances and regulations by the various towns of the watershed. Over time, we should all be able to build a growing sense of security and satisfaction as Watershed towns collectively enact a carefully crafted suite of coordinated provisions to best protect the natural resource base upon which we depend.

# OSSIPEE WATERSHED COALITION NATURAL RESOURCE PLANNING GUIDE

## **APPENDIX B: REVIEW PROCESS FOR ENACTING ZONING ORDINANCES AND REGULATIONS**

This section is geared to give municipal officials of the six towns within the Ossipee watershed and public citizens the general steps necessary for drafting and adopting zoning ordinances and regulations in their town.

Ordinances and regulations are a municipality's greatest tools for shaping the future of its community. Zoning ordinances must be approved by the voters, a process that gives the public a direct role in determining what is best for the future of their community.

Zoning ordinances are used as a way to direct development and types of land uses towards areas of town that are best able to accommodate them. Types of land uses may be segregated to balance the need for economic vitality with the desire to avoid harm to residential neighborhoods and sensitive natural resources. The zoning power must be used to protect the health, safety and general welfare of the municipality. See **RSA 674:17**.

Zoning ordinances are normally created by the municipality's planning board, but the selectmen can propose zoning amendments and voters can submit zoning amendments by petition.

Subdivision and site plan review regulations are adopted by the planning board and regulate the location of streets and utilities as well as provide for harmonious development, open spaces and prohibit "scattered and premature" development. See RSA 674:36 and RSA 674:44.

All zoning ordinances should have reference and support for their purpose in the town's Master Plan. Master Plans can be updated periodically by the planning board with a properly noticed public hearing and then voted on by the majority of the planning board. See **RSA 674:1**. The Master Plan provides the legal foundation for the zoning ordinances that implement the Master Plan's guiding principles. See **RSA 674:18**.

The purpose and intent of a zoning regulation should be included and clearly defined in the overall text.

All zoning ordinances and or amendments, regardless of their source, require at least one public hearing properly noticed and held by the planning board.

### **Towns with zoning:**

#### **Process for new Zoning Ordinances:**

Zoning ordinances are proposed by the Planning Board and are voted on by the registered town voters at the annual town meeting after at least one public hearing **RSA 675:3**. The Planning Board shall write and vote on the final version of the ordinance. If the text of the originally proposed ordinance is substantively altered by the planning board after a public hearing; a subsequent public hearing must be held at least 14 days after the prior public hearing and with notice as provided in **RSA 675:7**. The town clerk shall prepare the ordinance as a ballot vote.

A majority vote is required for passage.

- Zoning ordinance proposed by planning board.
- Public hearing held.
- Final version voted on by the planning board. (If substantively different from original, a second public hearing no less than 14 days after the prior must be noticed and held.)
- Adoption by ballot vote at town meeting.

**Petitioned zoning ordinances:**

Twenty-five or more voters may petition to amend existing zoning per **RSA 675:4**.

This petition must be submitted to the selectmen during the petition period (120 to 90 days prior to town meeting). The selectmen shall submit the petition(s) to the planning board in a timely manner. The planning board at its first regular meeting following the petition period shall set the date of the public hearing on each petitioned amendment and shall hold a public hearing on each petitioned amendment. Notice of hearings shall follow **RSA 675:7**.

The petitioned amendments shall be placed on the ballot with notation indicating whether the planning board approves or disapproves of the petitioned zoning amendment.

**Towns without zoning:**

Towns that do not have formal zoning can enact an emergency temporary zoning ordinance through the process outlined in **RSA 675:4-a**.

Upon written application of at least 5 percent of the town's registered voters, or by vote of the planning board, the selectmen shall call a special town meeting.

The planning board must hold a public hearing noticed not more than 7 calendar days before the special town meeting.

Adoption is by ballot vote. A majority is required for passage. If adopted, the provisions of RSA 674:24 to 674:30 are in effect in the town for two years or until the voters consider a zoning ordinance proposed by the planning board, whichever period of time is the lesser. If no zoning ordinance has been proposed for action by the time of the second annual town meeting, the selectmen shall include in the town meeting warrant an article to continue the temporary zoning ordinance for one additional year.

**Public Hearings: See RSA 675:7**

- Proper notice must be posted at least 10 calendar days before hearing
- Published in a local newspaper and in 2 public places.
- Must contain a description of the proposal.
- Must contain place where the entire text of the proposal can be read.

## Ossipee Watershed Coalition Natural Resources Guide Glossary

Definitions for the terms and acronyms included here are drawn from chapter contents, from included model ordinances, and from standard reference texts. Some terms that are defined clearly within the chapters and are used principally in the immediate surrounding discussion have not been repeated here.

Term/Acronym	Definition
Abiotic	Non-living chemical and physical factors in the environment. These may be classified as light, temperature, water, atmospheric gases, and wind as well as soil (edaphic) and physiographic (nature of land surface) factors.
Acidification	Reduced pH due to the acid deposition (via acidic rain, snow, or particulate fallout), and low geologically supplied acid neutralizing capacity or buffering in surface waters.
Aquifer	A subsurface layer of porous material (sand or gravel) or fractured bedrock that accumulates and retains water. See also Recharge area, High Yield Aquifer, Stratified Drift Aquifer.
BMPs	Best Management Practices Measures or practices proven or accepted as optimal to minimize negative impacts.
Basal area	A measure of the cross-sectional area of an object (e.g., tree) at ground level. In forestry, when used collectively within an area, it is a measure of forest density.
Basin, drainage	A larger regional portion of a watershed, often associated with a major river or other large scale water feature.
CSPA	Comprehensive Shoreland Protection Act -enacted in New Hampshire in 1994 (and modified in 2007) to protect water quality by preventing soil and other pollutants from entering any lake or pond.
Community	The living or biotic component of a setting, i.e., all the organisms present.
Contiguous	Immediately adjacent to; or, in the case of surface water or wetlands, hydrologically connected in a direct and proximal way – i.e., damage or degradation to one resource will likely cause damage or degradation to the contiguous resource.
Cultural eutrophication	Excessive increase in productivity of algal and plant growth of a lake due to the addition of nutrients from human activities such as fertilizing or septic leakage. This is indicated by lower water clarity, algal “blooms”, or increases in submerged and/or emergent vegetation.
Current use value	The assessed valuation per acre of open space land based upon the income-producing capability of the land in its current use and not its real estate market value.
DES	New Hampshire Department of Environmental Services ( <a href="http://www.des.state.nh.us/">http://www.des.state.nh.us/</a> )
Decibel	The practical unit of measurement for sound pressure level. The number of decibels of a measured sound is equal to 20 times the logarithm to the base 10 of the ratio of the sound pressure of the measured sound to the sound pressure of a standard sound (20 micropascals). It is abbreviated dB.
Disturbance	An event that impacts resource availability or environmental conditions such that the structure of ecosystems, communities, or populations is altered.
Draw-down	Periodic, intentional release of dammed water – often done seasonally.
Ecoregion	A continuous area with climate, soil, and topography conducive to permit the



Ossipee Watershed Coalition  
Natural Resources Guide Glossary

	development of a geographically distinct assemblage of vegetation.
Erosion	The wearing away of the ground surface as a result of the movement of wind, water, ice, and/or land disturbance activities.
Exotic species	Non-native plants that have become introduced either intentionally (e.g., as ornamentals or for sport) or accidentally (e.g., attached to boat hulls or from aquariums). See also Invasive Species.
Fragmentation	Reduction of a large habitat into small, scattered remnants.
GIS	Geographic Information System. GIS is a computerized tool able to capture, store, analyze, and display geographically referenced information (i.e., data identified according to location). Among other applications, GIS technology is especially useful for resource management and development planning. See also GPS.
GMCG	Green Mountain Conservation Group ( <a href="http://www.gmcg.org/">www.gmcg.org/</a> )
GPS	Global Positioning System. GPS is a radio navigation system that allows users to determine the exact geographic location of features of the landscape, including themselves or any other object marked by a mobile receiver. The 24 GPS satellites that orbit the earth at 10,600 miles are spaced so that from any point on earth, four satellites will be above the horizon to pin-point the location of any receiving device. Entered as GIS data, such precision information becomes useful in resource analysis. See also GIS.
GRANIT	New Hampshire Geographically Referenced Analysis and Information Transfer System ( <a href="http://www.granit.sr.unh.edu/">www.granit.sr.unh.edu/</a> )
Great Pond	A natural body of fresh water having an area of 10 acres or more. These are state-owned public waters, and are held in trust by the state for public use (RSA 271:20).
High Water Mark (Mean or Ordinary)	See Reference Line
High yield aquifer	Aquifer that connects to recharge area(s) by highly permeable soils that readily absorb precipitation and allow it to percolate and recharge rapidly. They support maximum transmissivity -- in excess of 2,000 ft <sup>2</sup> per day, sometimes at more than 8,000 ft <sup>2</sup> per day.
Hydric soils	Soils that are saturated, flooded or ponded long enough during the growing season to develop anaerobic conditions in the upper part, as defined by the USDA Soil Conservation Service, National Technical Committee for Hydric Soils.
Hydrology	The science dealing with water on, within, or above the earth's surface.
Hydrophytic vegetation	Macrophytic (i.e., larger) plant life growing in water, saturated soil or on a substrate that is at least periodically deficient in oxygen as a result of excessive water content. See also Hydric soils.
Impervious surface	Any area covered by material that impedes the infiltration of water into the soil. Examples of impervious surfaces include buildings, roofs, decks, patios, and paved, gravel, or crushed stone driveways, parking areas, and walkways.
Intermittent or seasonal stream	Any stream flows for sufficient time to develop and maintain a defined channel with some sign of regular scouring and/or deposition of soil material, but which often does not flow during dry portions of the year.
Invasive species	Exotic plants that encounter few restraints to rapid reproduction and spreading. Once introduced, aquatic invasives can grow out of control to exclude native species and to become a nuisance to human recreational uses for waterbodies to the point of

Ossipee Watershed Coalition  
Natural Resources Guide Glossary

	significantly impacting property values. See Exotic species.
LEAP	Lake Environment Assessment Program ( <a href="http://www.ossipeelake.org/programs/leap/index.php">www.ossipeelake.org/programs/leap/index.php</a> )
Lacustrine	Shallow lake habitat.
Light trespass	Light produced by a luminaire that shines beyond the boundaries of the property on which it is located.
Luminaire	A complete lighting system that includes a lamp or lamps and a fixture.
Macroinvertebrates	Invertebrate organisms large enough to be viewed by the naked eye, such as insect larvae, clams, snails, etc. Collectively referred to as "MIVs".
NHLA	New Hampshire Lakes Association ( <a href="http://www.nhlakes.org/">www.nhlakes.org/</a> )
NPDES	National Pollutant Discharge Elimination System
NRCS	Natural Resource Conservation Service ( <a href="http://www.nrcs.usda.gov/">www.nrcs.usda.gov/</a> )
NWI	National Wetland Inventory – branch of the U.S. Fish & Wildlife Service ( <a href="http://www.fws.gov/nwi/">www.fws.gov/nwi/</a> )
Non-point source pollution	Natural and human caused degradation to lakes and ponds resulting from substances generally distributed in the landscape that find their way into aquatic systems as precipitation waters washes over land surfaces.
OLA	Ossipee Lakes Alliance was formed in 2002 and is the first permanent organization dedicated to preserving and protecting Ossipee Lake and its surrounding land. ( <a href="http://www.ossipeelake.org/">www.ossipeelake.org/</a> )
OLNA	Ossipee Lake Natural Area ( <a href="http://www.ossipeelake.org/places/natural.php">www.ossipeelake.org/places/natural.php</a> )
OLT	Ossipee Lake and Tributaries program ( <a href="http://www.gmcg.org/water-quality.php">www.gmcg.org/water-quality.php</a> )
OWC	The Ossipee Watershed Coalition ( <a href="http://www.gmcg.org/gmcg.php?id=130">www.gmcg.org/gmcg.php?id=130</a> )
Ozone	O <sub>3</sub> . Ground-level ozone, commonly called "summertime smog", is a substance formed as a result of photochemical reactions between oxygen, volatile organic compounds (VOCs), and oxides of nitrogen (NO <sub>x</sub> ). It is measured in parts per billion (ppb).
PCS	Potential contamination sources
Particulate pollution	Consists of both solid and liquid particles that are less than 2.5 microns in diameter (a micron is a millionth of a meter). They result from burning of wood, diesel and other fuels, fly ash and emissions industrial plants, from dust generated from agriculture (plowing, burning off fields) and unpaved roads and construction, and condensation vapors. Particle concentrations are measured in micrograms per cubic meter (ug/m <sup>3</sup> ).
Point source pollution	Natural and human caused degradation to lakes and ponds which is derived from "specific entry locations" (e.g., effluent pipes, dump sites).
RIVERS	Regional Interstate Volunteers for the Ecosystems and Rivers of Saco program ( <a href="http://www.wrrc.unh.edu/pubs/annual%20reports/fy04/McDowell%20FY2004%20Progress%20report.pdf">www.wrrc.unh.edu/pubs/annual%20reports/fy04/McDowell%20FY2004%20Progress%20report.pdf</a> )
Recharge area	Surface land areas that are connected with the groundwater by highly porous soil and rock layers. In "Primary recharge areas", water infiltrates directly into the aquifer; in "Secondary recharge area", zones adjacent to the aquifer provide surface and groundwater that eventually recharge the aquifer; and "Tertiary recharge area" are those that supply water to streams that flow across the primary recharge area and may or may not recharge the aquifer depending on water levels.
Reference Line	The highest average level of water in certain wetlands and most surface water

Ossipee Watershed Coalition  
Natural Resources Guide Glossary











	bodies, as evidenced by water marks on trees or rocks, the limit of natural, upland vegetation along a shoreline, or the lower edge of floodwater debris. For all other wetlands including marshes, bogs, swamps and vernal pools the reference line shall be the line delineated as the wetland edge by a Certified Wetland Scientist. Reference lines are strictly defined as outlined in the CSPA, RSA 483-B.
Ridgeline	The linear trace of a topographic crest above a defined elevation, such as 700 feet in the Ossipee Watershed area.
Riparian areas	Land related to or adjacent to a stream or watercourse, although this term is now also sometimes used to describe wetland areas not necessarily associated with rivers or streams.
SRCC	Saco River Corridor Commission began its WQM program in 2001 and monitors 27 sites in twenty towns along the Saco River. ( <a href="http://www.srcc-maine.org/">www.srcc-maine.org/</a> )
SOC	Synthetic organic compounds, including pesticides and herbicides.
Scenic Road	A designation initiated upon petition and ratified by subsequent approval by voters. Designation as a Scenic Road means that repair, maintenance, and reconstruction work to the roadway should not involve the cutting or removal of trees 15” or more in diameter or the tearing down or destruction of stone walls without prior written consent of the board(s) responsible for the local scenic roads program.
Sedimentation	The process by which sediment resulting from accelerated erosion has been or is being transported off the site of the land-disturbing activity or into a lake or natural watercourse or wetland.
Siltation	The process of settling out or depositing of fine particulate matter.
Slope	The degree of deviation of a surface from the horizontal, usually expressed in percent or degrees; rise over run.
Stratified drift aquifer	A subsurface layer of highly porous sand and gravel soil deposited by melting glaciers that accumulates and retains water. These aquifers are considered high yield due to the high level of recharge. See also Recharge Area.
Stream order	A classification system for streams based on stream size hierarchy. The smaller the stream, the lower its numerical classification. For example, a first order stream does not have tributaries and normally originates from springs or seeps. At the confluence of two first order streams, a second order stream begins and at the confluence of two second order streams, a third order stream begins, et.seq. First order streams can be either intermittent or perennial.
Subwatershed	A smaller subdivision of a watershed contributes a portion of the total watershed drainage.
Surficial geology	The study of surface features of the landscape, as compared to underlying, or subsurface bedrock features.
Talus slope	A sloping mass of rock fragments along or towards the bottom of a cliff.
Transmissivity	A measure of the ability of a medium (e.g., a geological deposit) to permit through-passage of an entity (e.g., groundwater). Fluid flow rate.
VBAP	Volunteer Bio-monitoring Assessment Program ( <a href="http://www.des.state.nh.us/wmb/documents/Cocheco06_VBAP.pdf">www.des.state.nh.us/wmb/documents/Cocheco06_VBAP.pdf</a> )
VLAP	New Hampshire Volunteer Lake Assessment Program initiated in 1985. This program serves a dual purpose by establishing a regular volunteer-driven lake sampling program to assist DES in evaluating lake quality throughout the state, and by empowering volunteer monitors and lake residents with information about the

Ossipee Watershed Coalition  
Natural Resources Guide Glossary

	health of their waterbody. This cooperative effort allows biologists and lake associations to make educated decisions regarding the future of New Hampshire's lakes and ponds. ( <a href="http://www.des.state.nh.us/WMB/vlap/">www.des.state.nh.us/WMB/vlap/</a> )
VOC	Volatile organic compounds that include vapors such as the gasoline additive MtBE and industrial solvents.
Vernal pool	A seasonal body of standing water that typically forms in the spring from melting snow and other runoff. Water must be present for at least two continuous months in the spring and/or summer, but the stream becomes completely dry during a portion of the year, usually in the hotter months of summer. Vernal pools range from broad, heavily vegetated lowland bodies to smaller, isolated upland bodies with little permanent vegetation. They are free of fish and provide important breeding habitat for many terrestrial or semi-aquatic species, including wood frogs ( <i>Rana sylvatica</i> ), breeding mole ( <i>Ambystomid</i> ) salamanders, and fairy shrimp.
Viewshed	An area of land, water, and other environmental elements that is visible from a fixed vantage point. Viewsheds can be areas of particular scenic or historic value that are deemed worthy of preservation against development or other change.
WAP	New Hampshire Wildlife Action Plan, a statewide strategy for identifying, restoring and maintaining critical habitats and populations of wildlife species of conservation and management concern. ( <a href="http://www.wildlife.state.nh.us/Wildlife/wildlife_plan.htm">www.wildlife.state.nh.us/Wildlife/wildlife_plan.htm</a> )
Watershed	The area of land that water runs over, across, and under on its way to the lowest point, often draining into a particular water body. See also Subwatershed, Basin Drainage.
Water supply lands	See Recharge area.
Wellhead Protection Area (WHPA)	A circular area of land centered over a well, drawn at a radius related to the well's capacity. It represents the area through which contaminants are reasonably likely to move toward and reach such water well or wellfield.
Wetland	Areas that are inundated or saturated by surface or groundwater at a frequency and duration to support and that under normal circumstances do support, a prevalence of vegetation typically adapted to life in saturated soil conditions. Prime Wetlands, that have be so designated under RSA 482-A:15, are of substantial significance to society due to their "size, unspoiled character, fragile condition, or other relevant factors."
Wetland hydrology	Permanent or periodic inundation or soil saturation to the surface at least seasonally during the average rainfall year.

# Ossipee River Watershed WATER RESOURCES

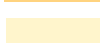
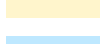
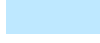
## Legend

-  Ossipee River Watershed (NHDES)
- Stratified Drift Aquifer (NHDES) transmissivity ft<sup>2</sup>/day**
  -  Less than 1000 ft<sup>2</sup>/day
  -  1000 to 2000
  -  2000 to 4000
  -  4000 to 8000
  -  Over 8000
  -  Unable to contour
-  Secondary Aquifer Recharge Area
-  Tertiary Aquifer Recharge Area
-  Surface Water (NHD, GRANIT)
-  Wetland (NWI), Hydric soil (NRCS)
-  Conservation Land (GRANIT)

Aquifer recharge area data provided by the Society for the Protection of NH Forests; delineation by Dr. Robert Newton, Smith College Spatial Analysis Lab, June 2001.

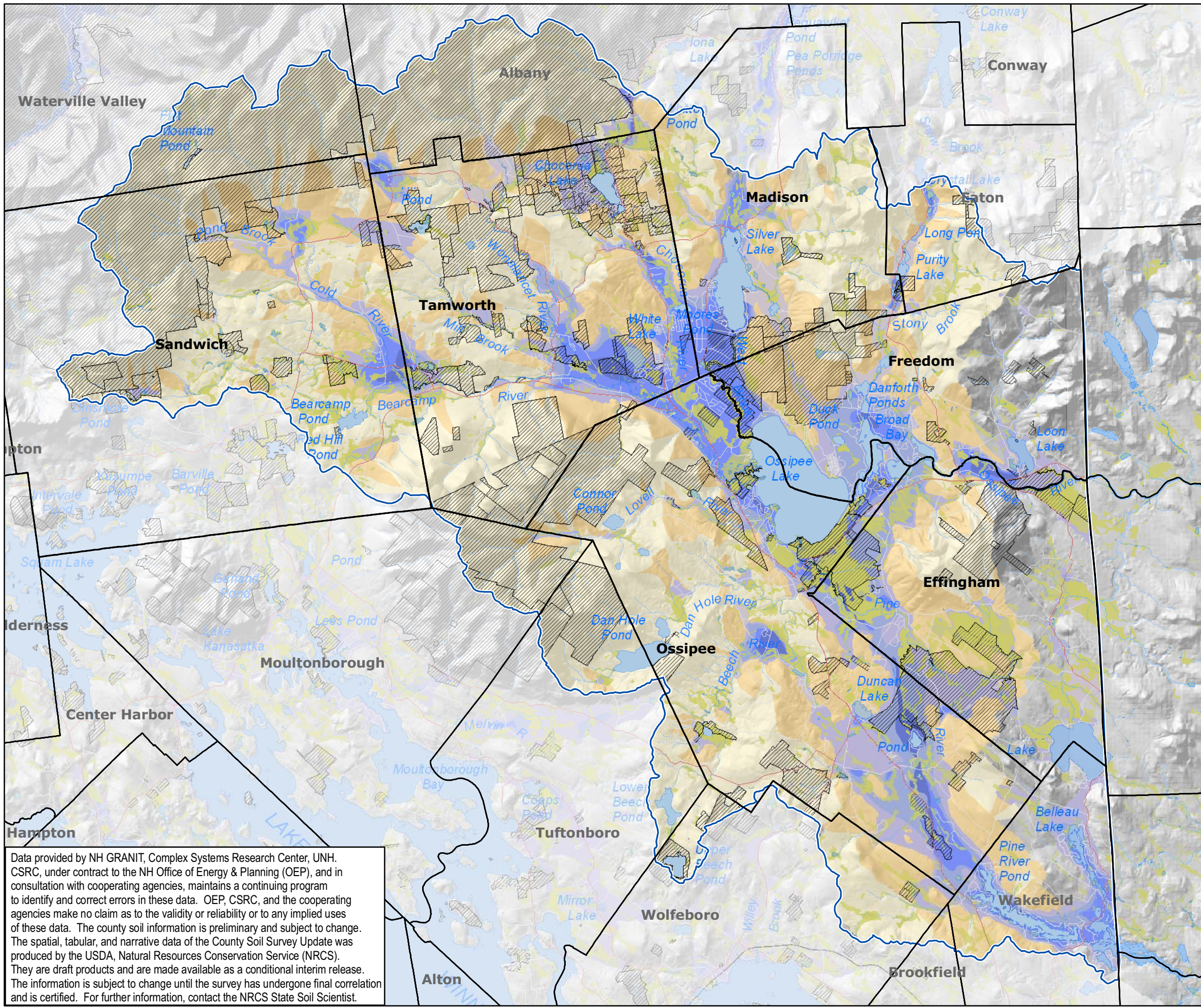

Data provided by NH GRANIT, Complex Systems Research Center, UNH. CSRC, under contract to the NH Office of Energy & Planning (OEP), and in consultation with cooperating agencies, maintains a continuing program to identify and correct errors in these data. OEP, CSRC, and the cooperating agencies make no claim as to the validity or reliability or to any implied uses of these data. The county soil information is preliminary and subject to change. The spatial, tabular, and narrative data of the County Soil Survey Update was produced by the USDA, Natural Resources Conservation Service (NRCS). They are draft products and are made available as a conditional interim release. The information is subject to change until the survey has undergone final correlation and is certified. For further information, contact the NRCS State Soil Scientist.



0 Miles 4 8  
September 2007

# New Hampshire WILDLIFE HABITAT LAND COVER

Locations of known and potential critical wildlife habitat in the state.

- Floodplain Forest
- Grassland (25+ac)
- Pine barren
- Cave or Mine (not shown)
- Cliff
- Rocky ridge or Talus slope
- Coastal Island
- Dune
- Salt marsh
- Peatland
- Wet meadow/  
Shrub wetland
- Alpine
- High-elevation Spruce-fir
- Lowland Spruce-fir
- Northern hardwood-conifer
- Appalachian oak-pine
- Hemlock-hardwood-pine
- Other forest type <5ac; shrubland;  
small grassland <25ac; cleared; or  
light residential development
- Unfragmented Block of natural  
land cover (labeled by total acres)



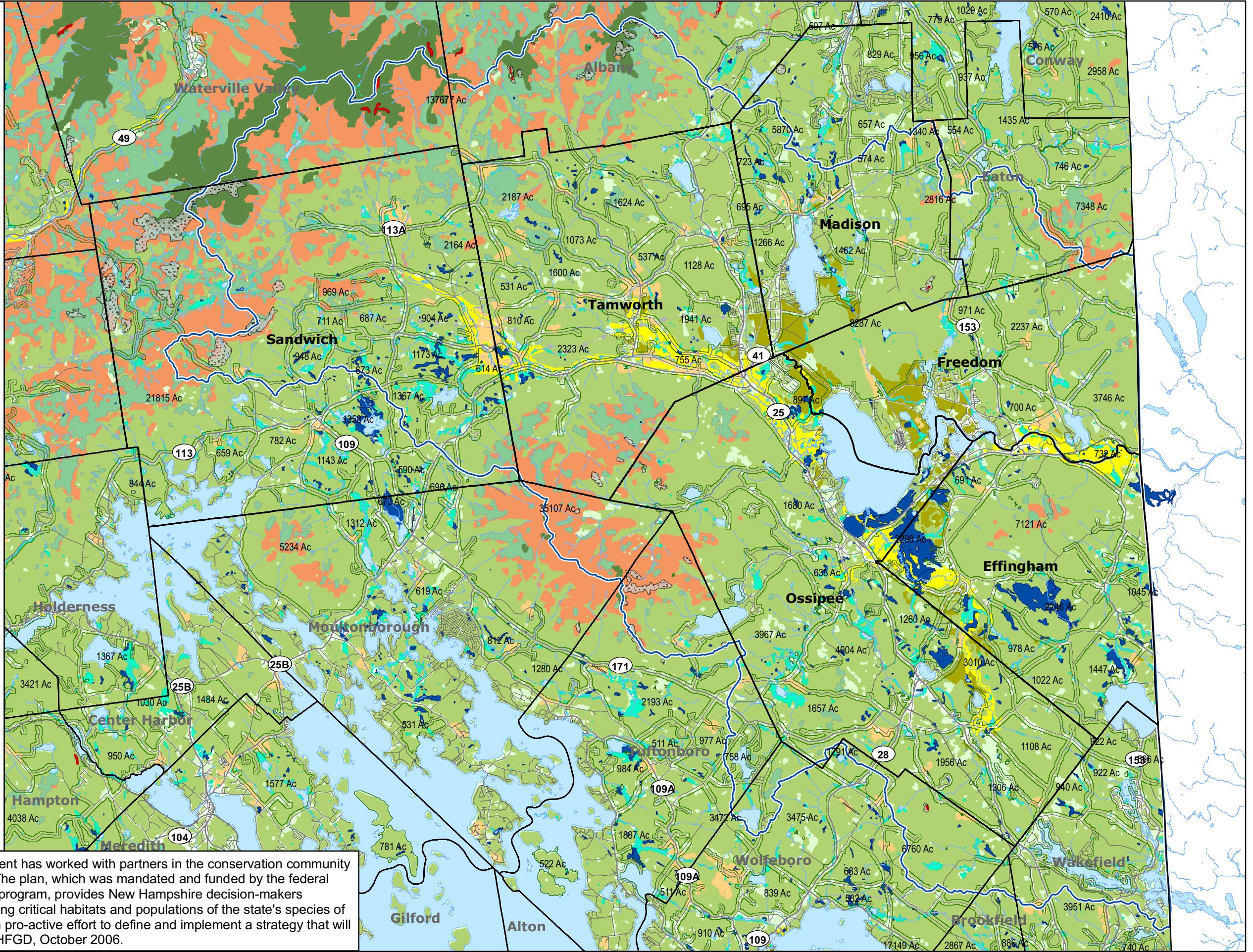



**NEW HAMPSHIRE  
Wildlife Action  
Plan**

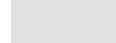

The New Hampshire Fish and Game Department has worked with partners in the conservation community to create the state's first Wildlife Action Plan. The plan, which was mandated and funded by the federal government through the State Wildlife Grants program, provides New Hampshire decision-makers with important tools for restoring and maintaining critical habitats and populations of the state's species of conservation and management concern. It is a pro-active effort to define and implement a strategy that will help keep species off of rare species lists. NHFGD, October 2006.

# Ossipee River Watershed ELEVATION, RIDGELINES AND STEEP SLOPES

**Legend**

-  Ossipee River Watershed (NHDES)
- ELEVATION (USGS digital elevation model)**
-  Above 700 Ft
-  Below 700 Ft
- Steep Slopes (derived from USGS dem)**
-  15 to 25 percent slope
-  Over 25 percent slope
-  Ridgelines above 700 Ft elevation (flowaccumulation of USGS dem)

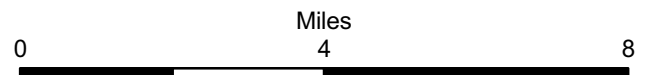
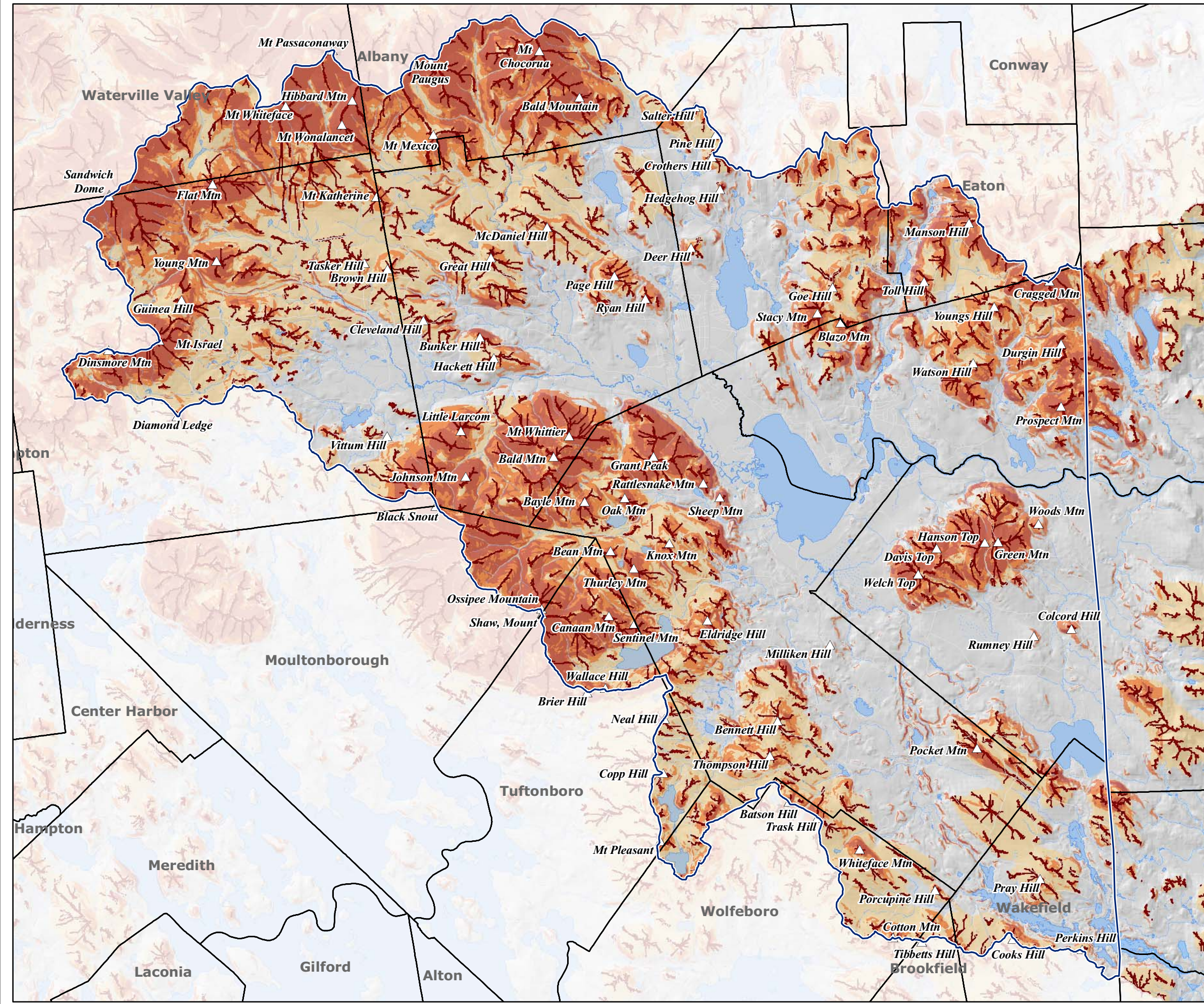

# Ossipee River Watershed ELEVATION, RIDGELINES AND STEEP SLOPES



**Legend**

-  Ossipee River Watershed (NHDES)

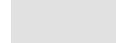
**ELEVATION (USGS digital elevation model)**

-  Above 700 Ft
-  Below 700 Ft

**Steep Slopes (derived from USGS dem)**

-  15 to 25 percent slope
-  Over 25 percent slope
-  Ridgelines above 700 Ft elevation (flowaccumulation of USGS dem)

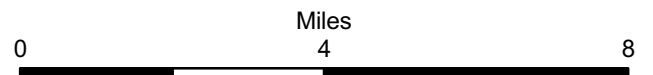
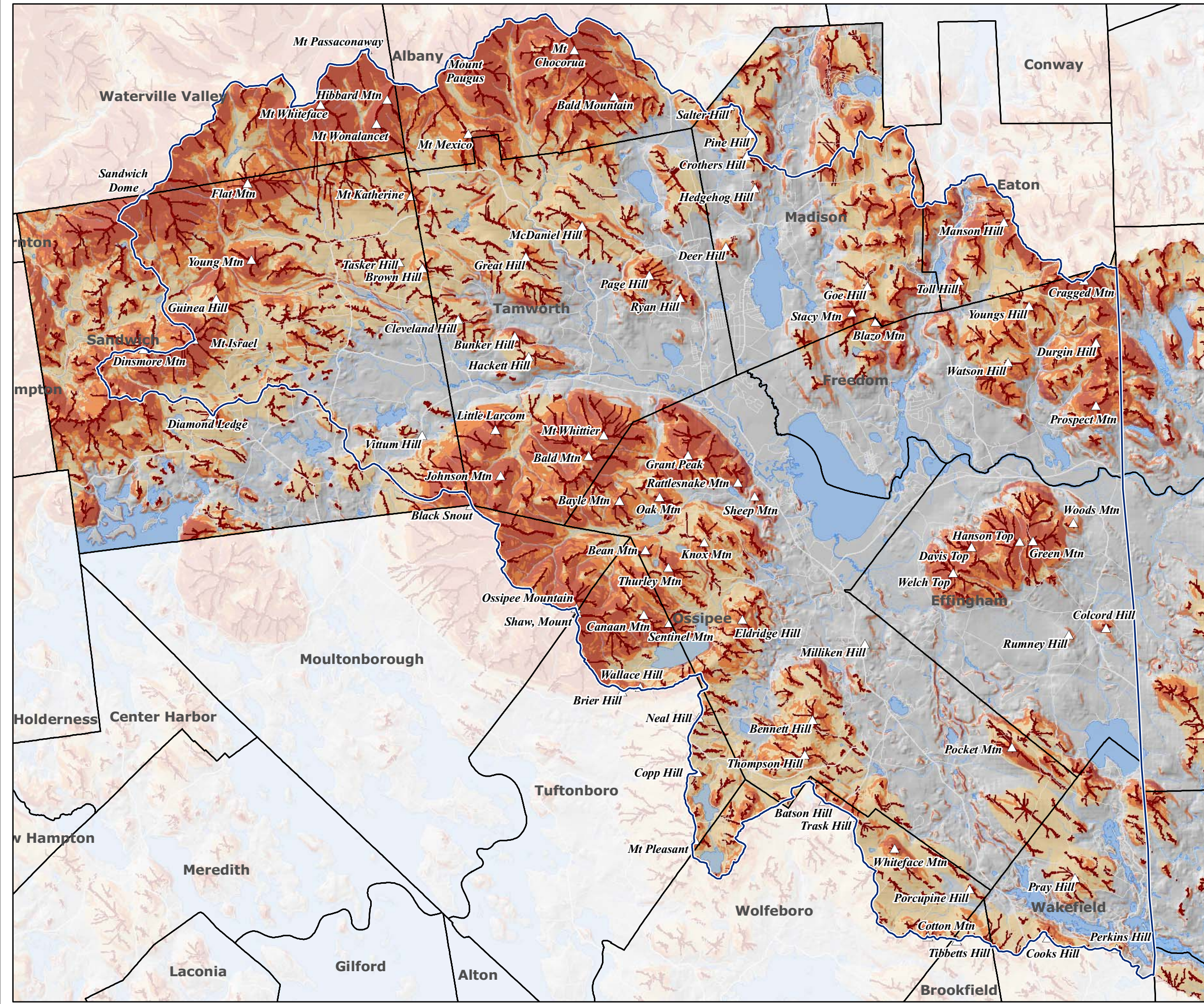



# Town of Effingham WATER RESOURCES

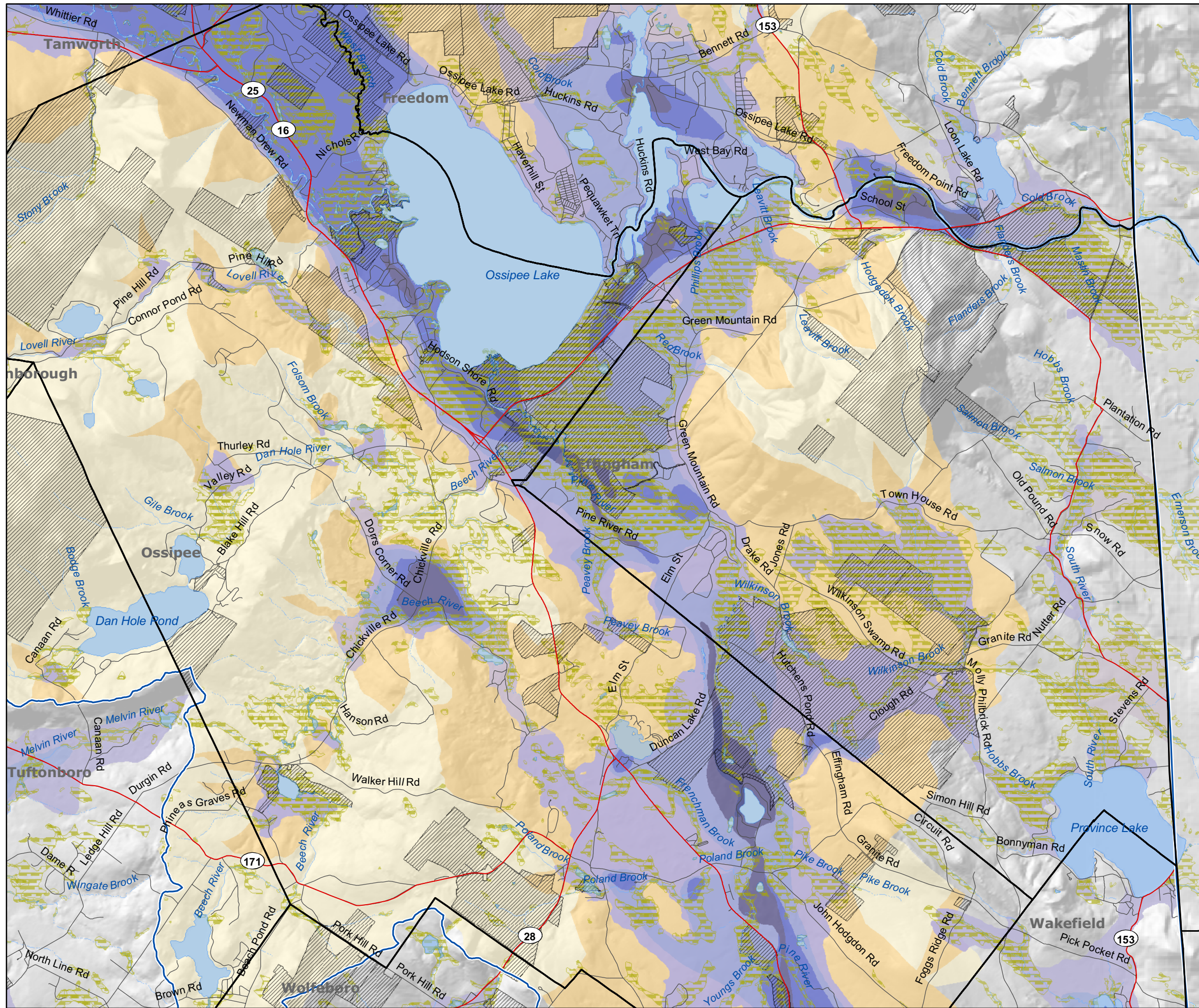

## Legend

- Ossipee River Watershed (NHDES)
- Stratified Drift Aquifer (NHDES) transmissivity ft<sup>2</sup>/day**
- Less than 1000 ft<sup>2</sup>/day
- 1000 to 2000
- 2000 to 4000
- 4000 to 8000
- Over 8000
- Unable to contour
- Secondary Aquifer Recharge Area
- Tertiary Aquifer Recharge Area
- Surface Water (NHD, GRANIT)
- Wetland (NWI), Hydric soil (NRCS)
- Conservation Land (GRANIT)

Aquifer recharge area data provided by the Society for the Protection of NH Forests; delineation by Dr. Robert Newton, Smith College Spatial Analysis Lab, June 2001.









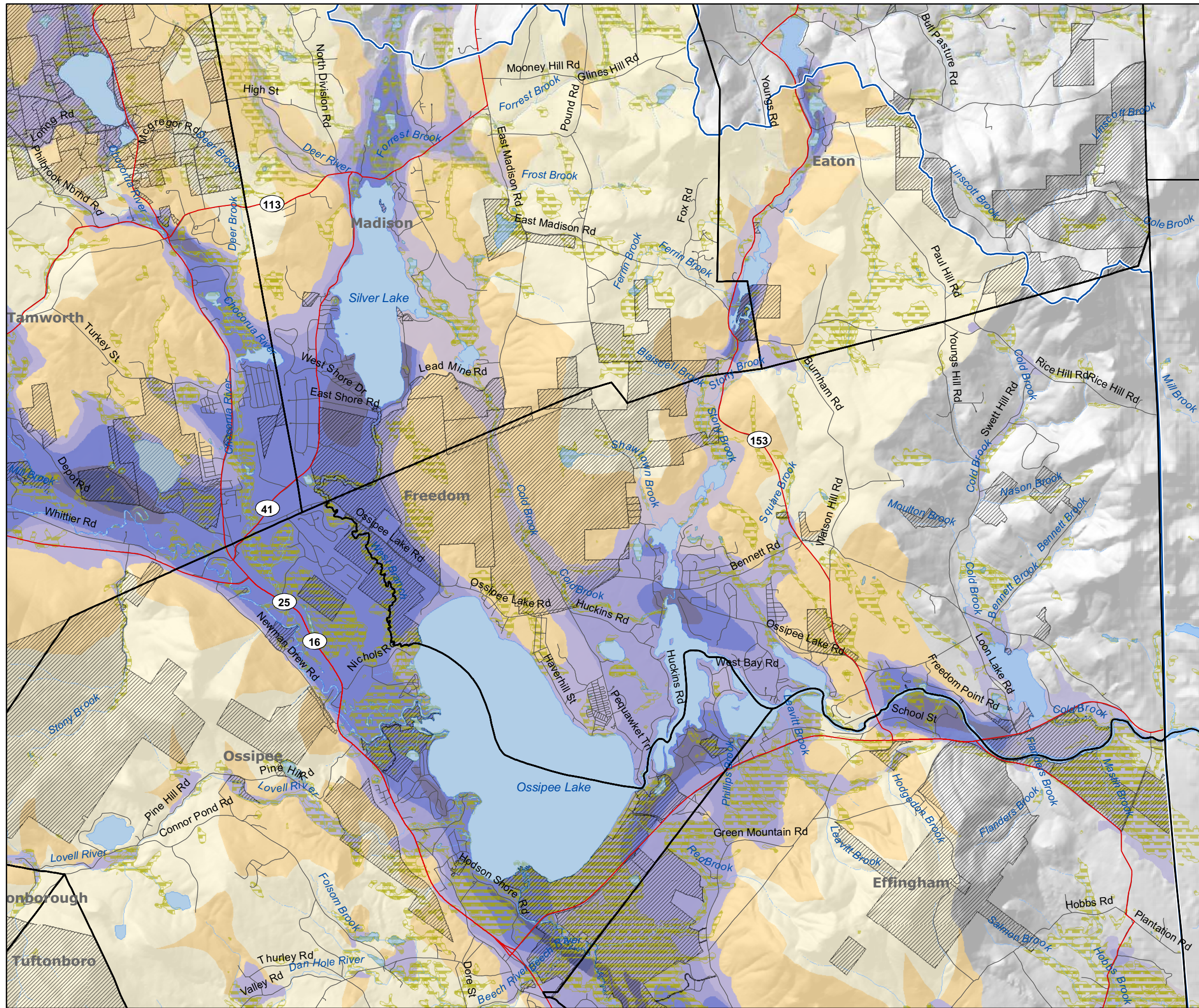



September 2007



# Town of Freedom WATER RESOURCES

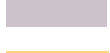

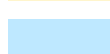
## Legend

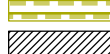
-  Ossipee River Watershed (NHDES)
- Stratified Drift Aquifer (NHDES) transmissivity ft<sup>2</sup>/day**
  -  Less than 1000 ft<sup>2</sup>/day
  -  1000 to 2000
  -  2000 to 4000
  -  4000 to 8000
  -  Over 8000
  -  Unable to contour
-  Secondary Aquifer Recharge Area
-  Tertiary Aquifer Recharge Area
-  Surface Water (NHD, GRANIT)
-  Wetland (NWI), Hydric soil (NRCS)
-  Conservation Land (GRANIT)

Aquifer recharge area data provided by the Society for the Protection of NH Forests; delineation by Dr. Robert Newton, Smith College Spatial Analysis Lab, June 2001.









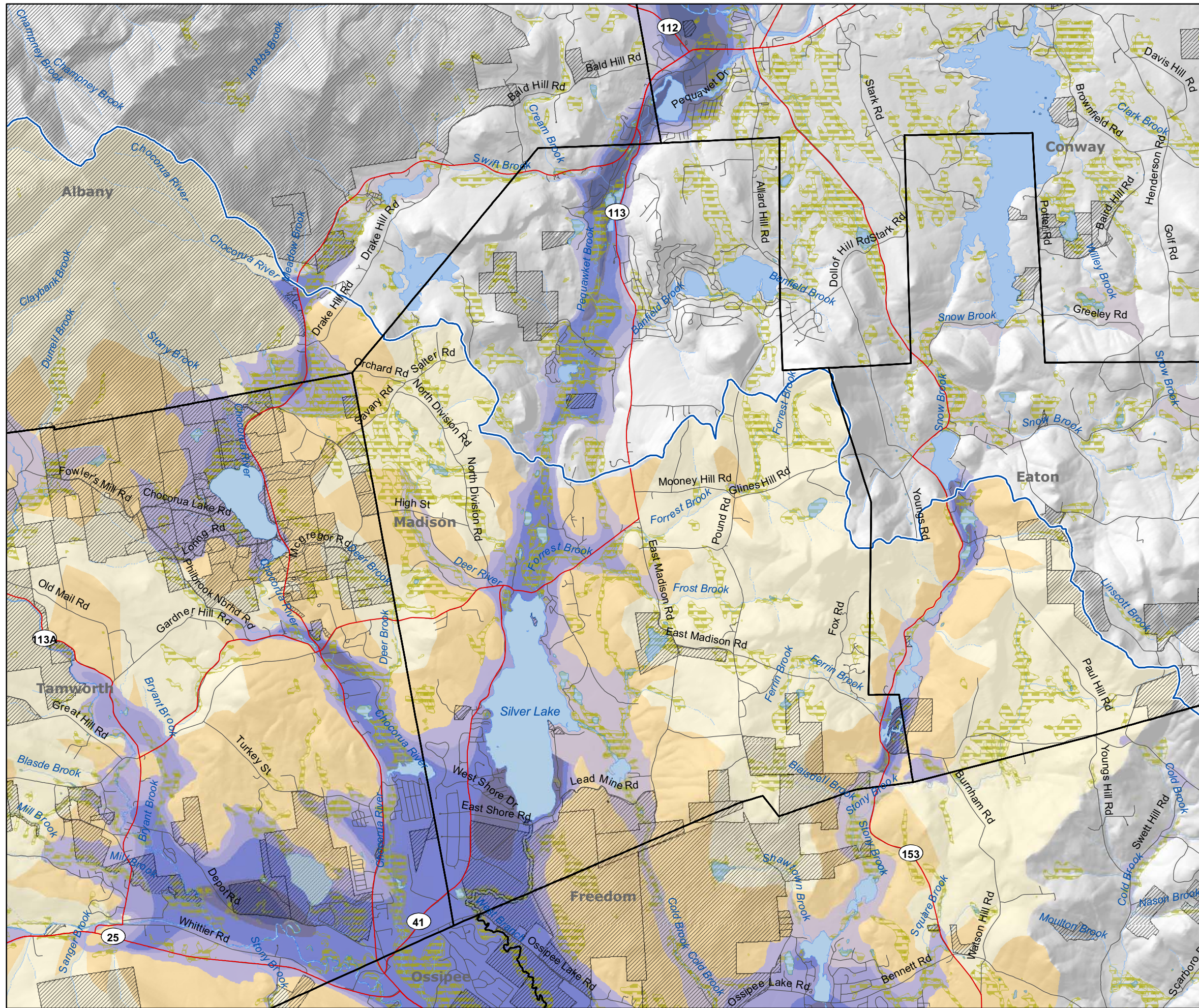



September 2007



# Town of Madison WATER RESOURCES

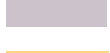

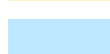
## Legend

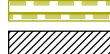
-  Ossipee River Watershed (NHDES)
- Stratified Drift Aquifer (NHDES) transmissivity ft<sup>2</sup>/day**
  -  Less than 1000 ft<sup>2</sup>/day
  -  1000 to 2000
  -  2000 to 4000
  -  4000 to 8000
  -  Over 8000
  -  Unable to contour
-  Secondary Aquifer Recharge Area
-  Tertiary Aquifer Recharge Area
-  Surface Water (NHD, GRANIT)
-  Wetland (NWI), Hydric soil (NRCS)
-  Conservation Land (GRANIT)

Aquifer recharge area data provided by the Society for the Protection of NH Forests; delineation by Dr. Robert Newton, Smith College Spatial Analysis Lab, June 2001.









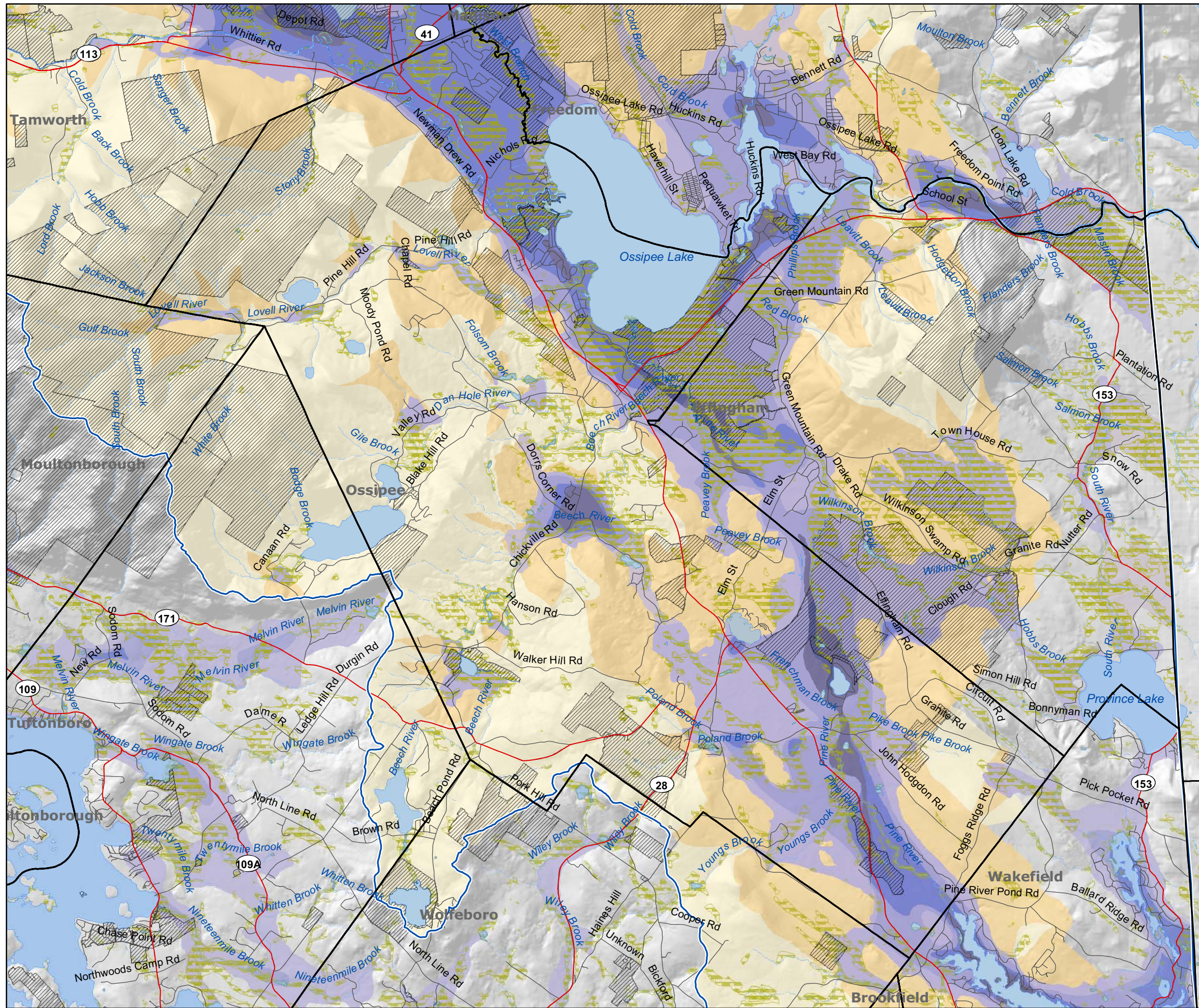



September 2007



# Town of Ossipee WATER RESOURCES

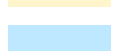

## Legend

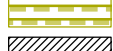
-  Ossipee River Watershed (NHDES)
- Stratified Drift Aquifer (NHDES) transmissivity ft<sup>2</sup>/day**
  -  Less than 1000 ft<sup>2</sup>/day
  -  1000 to 2000
  -  2000 to 4000
  -  4000 to 8000
  -  Over 8000
  -  Unable to contour
-  Secondary Aquifer Recharge Area
-  Tertiary Aquifer Recharge Area
-  Surface Water (NHD, GRANIT)
-  Wetland (NWI), Hydric soil (NRCS)
-  Conservation Land (GRANIT)

Aquifer recharge area data provided by the Society for the Protection of NH Forests; delineation by Dr. Robert Newton, Smith College Spatial Analysis Lab, June 2001.









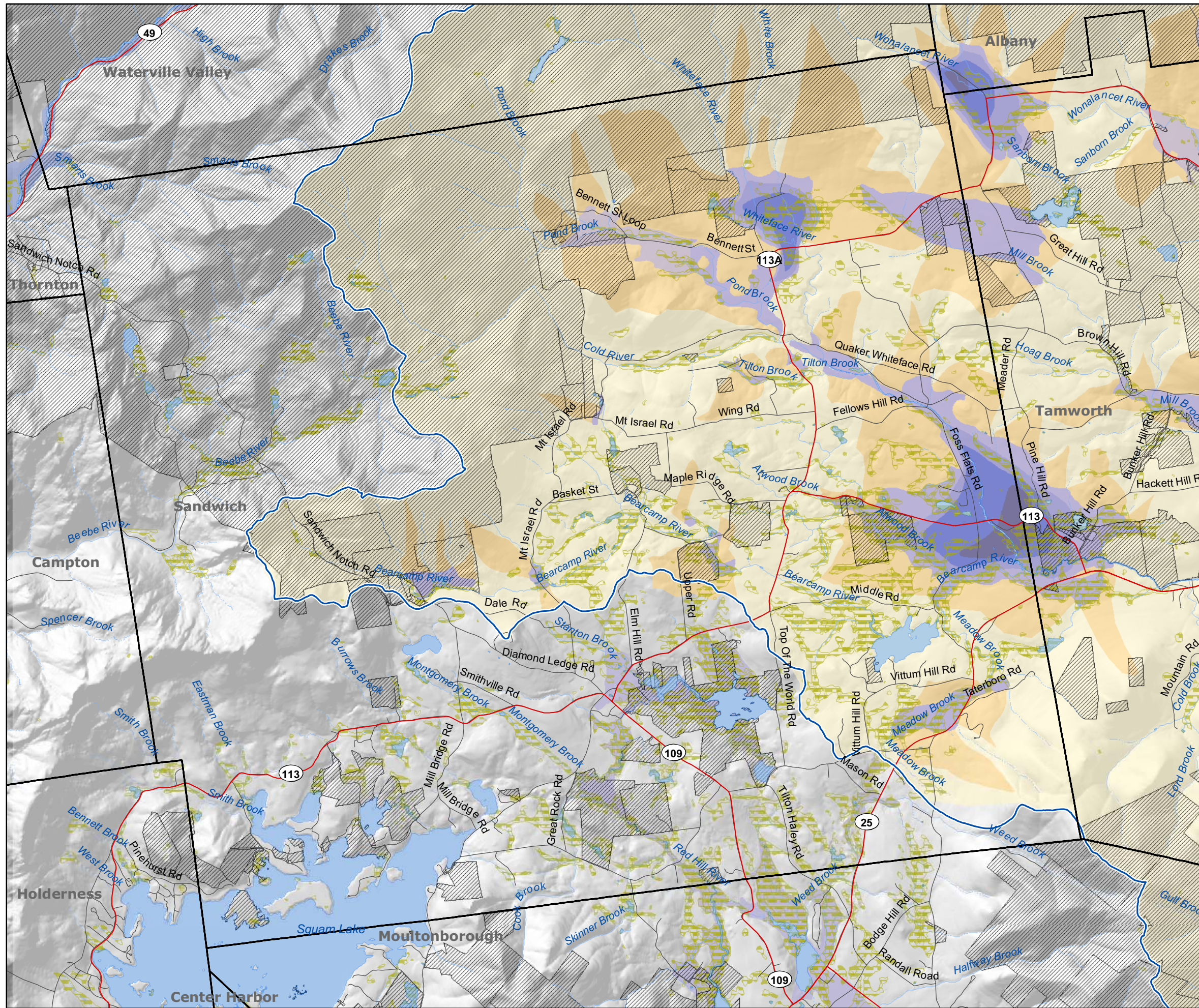



September 2007



# Town of Sandwich WATER RESOURCES

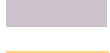

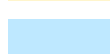
## Legend

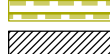
-  Ossipee River Watershed (NHDES)
- Stratified Drift Aquifer (NHDES) transmissivity ft<sup>2</sup>/day**
-  Less than 1000 ft<sup>2</sup>/day
-  1000 to 2000
-  2000 to 4000
-  4000 to 8000
-  Over 8000
-  Unable to contour
-  Secondary Aquifer Recharge Area
-  Tertiary Aquifer Recharge Area
-  Surface Water (NHD, GRANIT)
-  Wetland (NWI), Hydric soil (NRCS)
-  Conservation Land (GRANIT)

Aquifer recharge area data provided by the Society for the Protection of NH Forests; delineation by Dr. Robert Newton, Smith College Spatial Analysis Lab, June 2001.









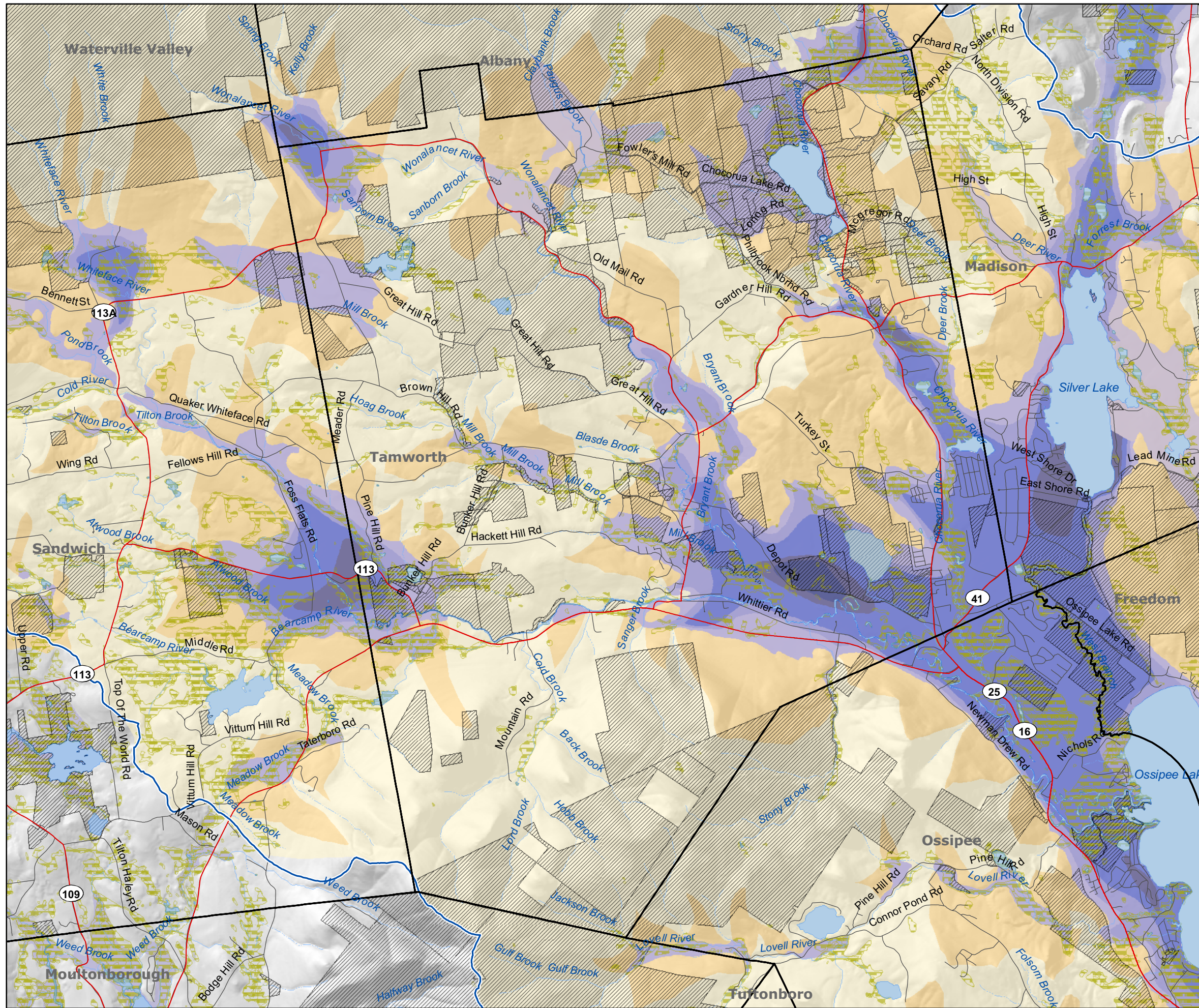



September 2007



# Town of Tamworth WATER RESOURCES

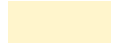
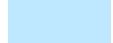

## Legend

-  Ossipee River Watershed (NHDES)
- Stratified Drift Aquifer (NHDES) transmissivity ft<sup>2</sup>/day**
  -  Less than 1000 ft<sup>2</sup>/day
  -  1000 to 2000
  -  2000 to 4000
  -  4000 to 8000
  -  Over 8000
  -  Unable to contour
-  Secondary Aquifer Recharge Area
-  Tertiary Aquifer Recharge Area
-  Surface Water (NHD, GRANIT)
-  Wetland (NWI), Hydric soil (NRCS)
-  Conservation Land (GRANIT)

Aquifer recharge area data provided by the Society for the Protection of NH Forests; delineation by Dr. Robert Newton, Smith College Spatial Analysis Lab, June 2001.



















September 2007



# NEW HAMPSHIRE WILDLIFE HABITAT LAND COVER

Locations of known and potential critical wildlife habitat in the state.

-  Peatland
-  Wet meadow/Shrub wetland
-  Forest Floodplain
-  Grassland (25+ac)
-  Pine barren
-  Cliff
-  Rocky ridge or Talus slope
-  Alpine
-  High-elevation Spruce-fir
-  Lowland Spruce-fir
-  Northern hardwood-conifer
-  Appalachian oak-pine
-  Hemlock-hardwood-pine
-  Other forest type <5ac; shrubland; small grassland <25ac; cleared; or light residential development
-  Unfragmented Block of natural land cover (labeled by total acres)
-  Ossipee River watershed

*coastal islands, dunes, and salt marsh not in map extent*

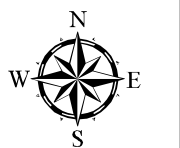
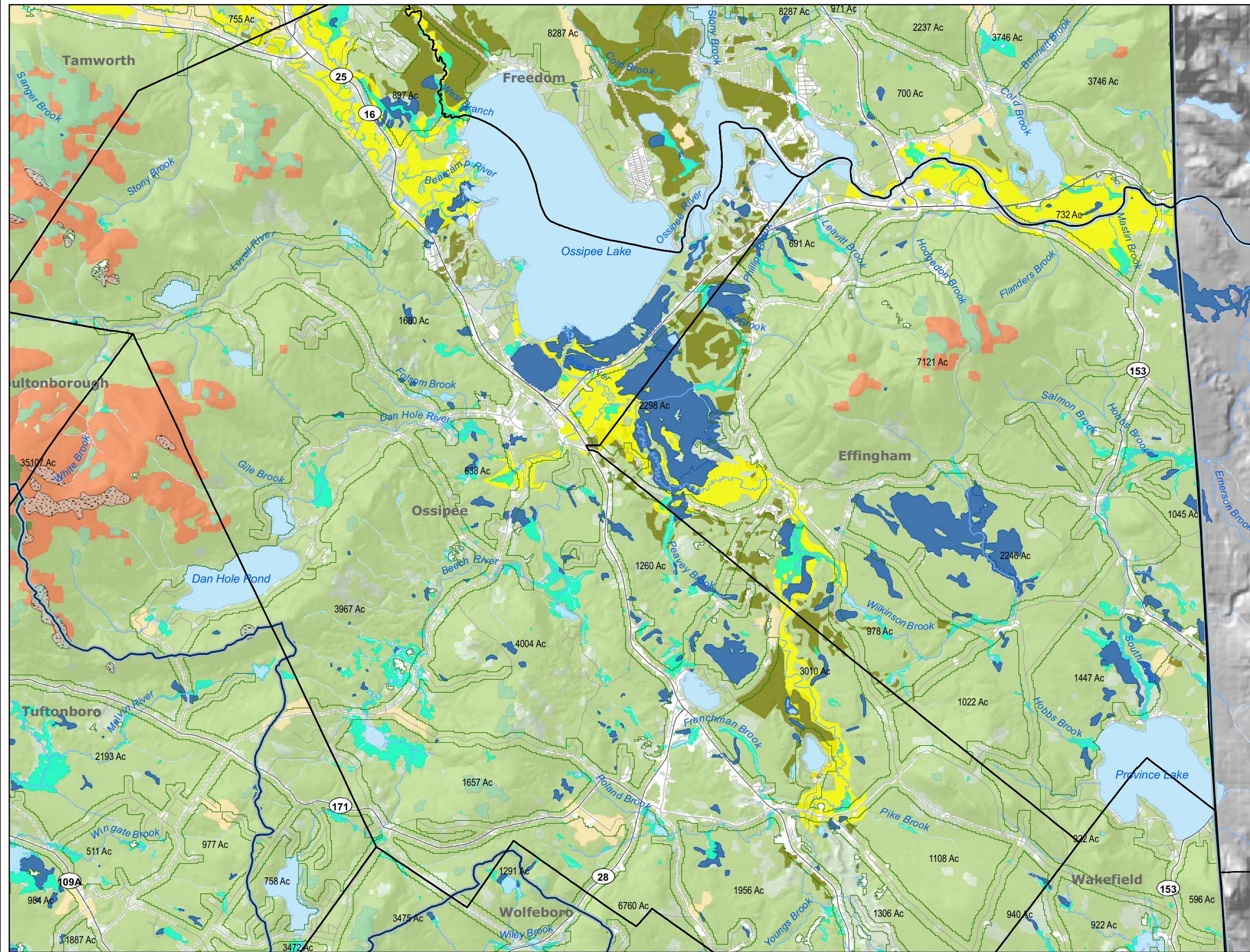



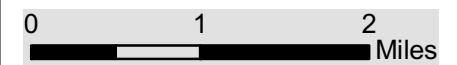













September 2007



# NEW HAMPSHIRE WILDLIFE HABITAT LAND COVER

Locations of known and potential critical wildlife habitat in the state.

-  Peatland
-  Wet meadow/Shrub wetland
-  Forest Floodplain
-  Grassland (25+ac)
-  Pine barren
-  Cliff
-  Rocky ridge or Talus slope
-  Alpine
-  High-elevation Spruce-fir
-  Lowland Spruce-fir
-  Northern hardwood-conifer
-  Appalachian oak-pine
-  Hemlock-hardwood-pine
-  Other forest type <5ac; shrubland; small grassland <25ac; cleared; or light residential development
-  Unfragmented Block of natural land cover (labeled by total acres)
-  Ossipee River watershed

*coastal islands, dunes, and salt marsh not in map extent*

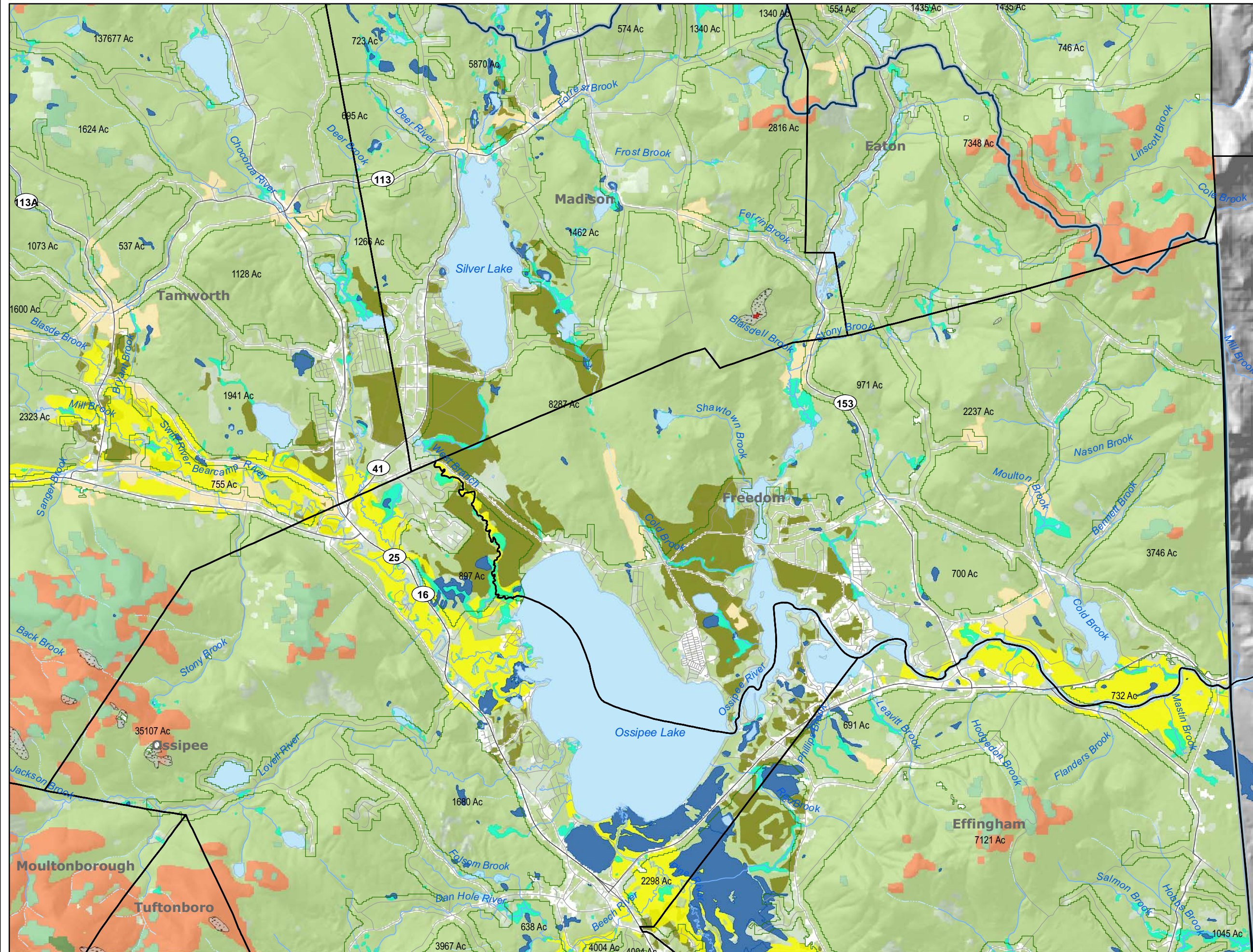



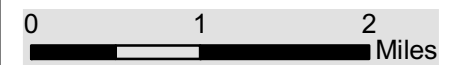













September 2007





# NEW HAMPSHIRE WILDLIFE HABITAT LAND COVER

Locations of known and potential critical wildlife habitat in the state.

-  Peatland
-  Wet meadow/Shrub wetland
-  Forest Floodplain
-  Grassland (25+ac)
-  Pine barren
-  Cliff
-  Rocky ridge or Talus slope
-  Alpine
-  High-elevation Spruce-fir
-  Lowland Spruce-fir
-  Northern hardwood-conifer
-  Appalachian oak-pine
-  Hemlock-hardwood-pine
-  Other forest type <5ac; shrubland; small grassland <25ac; cleared; or light residential development
-  Unfragmented Block of natural land cover (labeled by total acres)
-  Ossipee River watershed

*coastal islands, dunes, and salt marsh not in map extent*

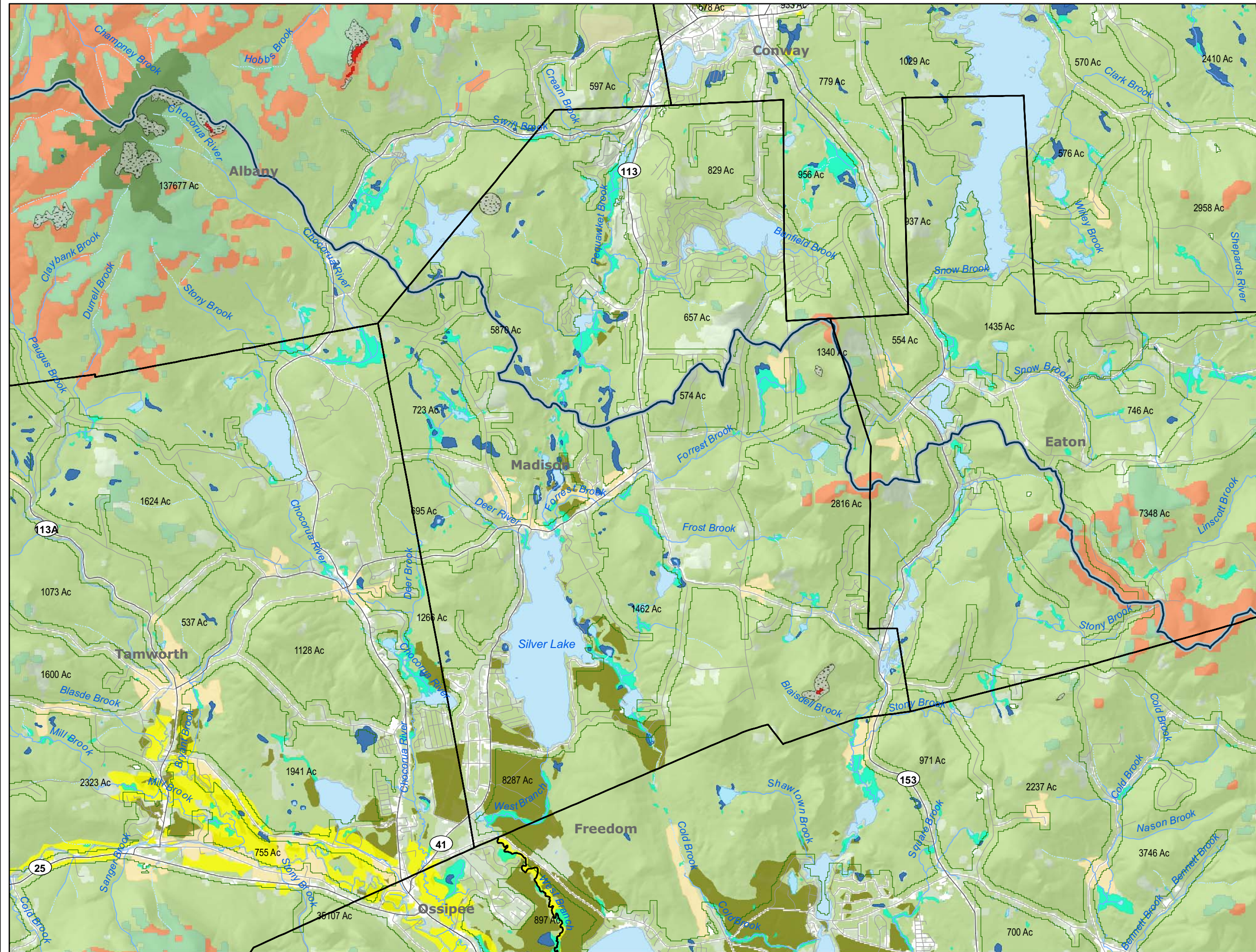



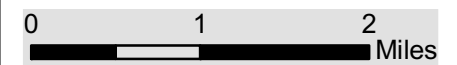













September 2007



# NEW HAMPSHIRE WILDLIFE HABITAT LAND COVER

Locations of known and potential critical wildlife habitat in the state.

-  Peatland
-  Wet meadow/Shrub wetland
-  Forest Floodplain
-  Grassland (25+ac)
-  Pine barren
-  Cliff
-  Rocky ridge or Talus slope
-  Alpine
-  High-elevation Spruce-fir
-  Lowland Spruce-fir
-  Northern hardwood-conifer
-  Appalachian oak-pine
-  Hemlock-hardwood-pine
-  Other forest type <5ac; shrubland; small grassland <25ac; cleared; or light residential development
-  Unfragmented Block of natural land cover (labeled by total acres)
-  Ossipee River watershed

*coastal islands, dunes, and salt marsh not in map extent*

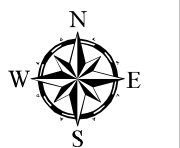
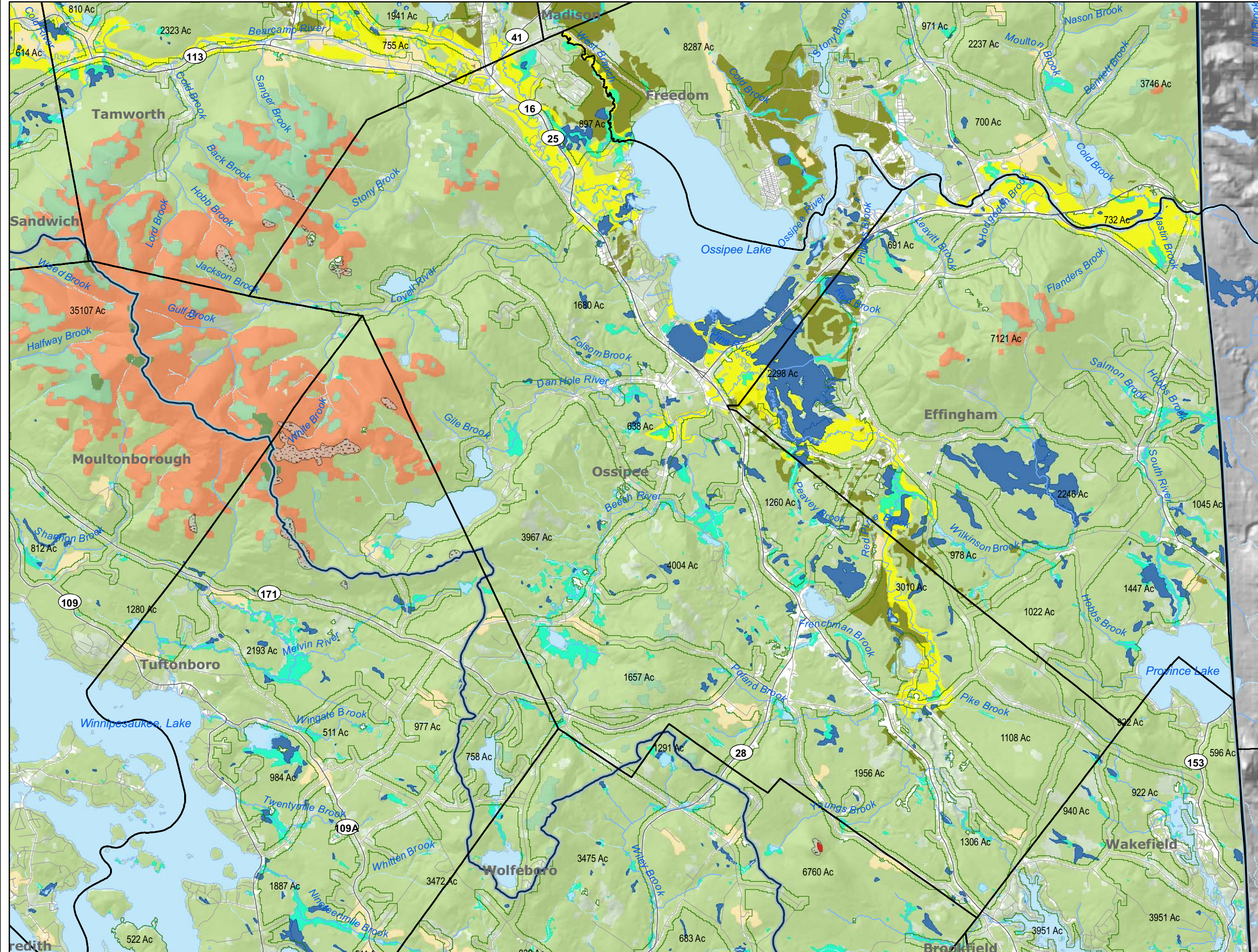



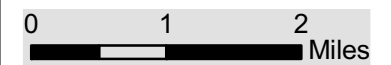













September 2007



# NEW HAMPSHIRE WILDLIFE HABITAT LAND COVER

Locations of known and potential critical wildlife habitat in the state.

-  Peatland
-  Wet meadow/Shrub wetland
-  Forest Floodplain
-  Grassland (25+ac)
-  Pine barren
-  Cliff
-  Rocky ridge or Talus slope
-  Alpine
-  High-elevation Spruce-fir
-  Lowland Spruce-fir
-  Northern hardwood-conifer
-  Appalachian oak-pine
-  Hemlock-hardwood-pine
-  Other forest type <5ac; shrubland; small grassland <25ac; cleared; or light residential development
-  Unfragmented Block of natural land cover (labeled by total acres)
-  Ossipee River watershed

*coastal islands, dunes, and salt marsh not in map extent*

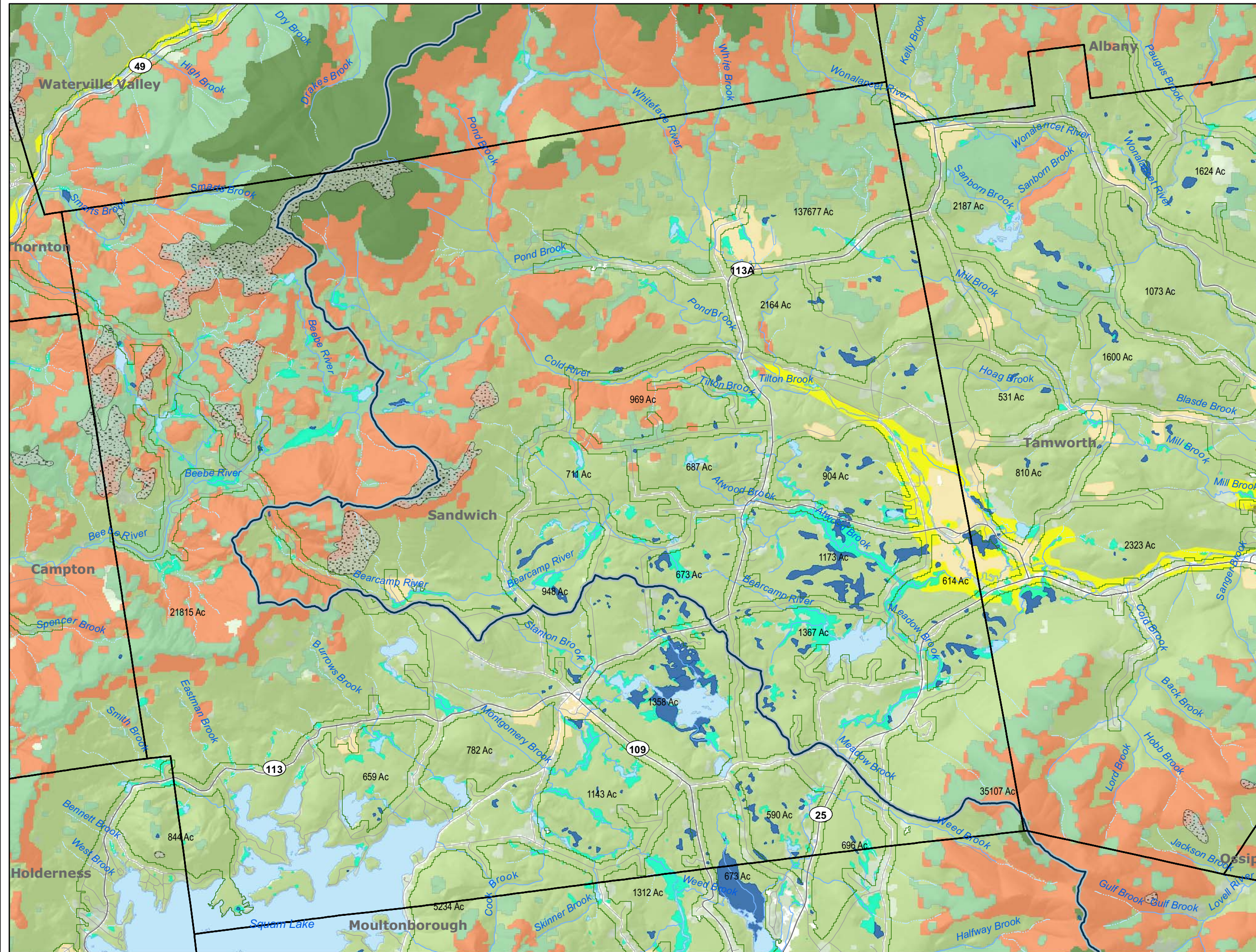

















September 2007



# NEW HAMPSHIRE WILDLIFE HABITAT LAND COVER

Locations of known and potential critical wildlife habitat in the state.

-  Peatland
-  Wet meadow/Shrub wetland
-  Forest Floodplain
-  Grassland (25+ac)
-  Pine barren
-  Cliff
-  Rocky ridge or Talus slope
-  Alpine
-  High-elevation Spruce-fir
-  Lowland Spruce-fir
-  Northern hardwood-conifer
-  Appalachian oak-pine
-  Hemlock-hardwood-pine
-  Other forest type <5ac; shrubland; small grassland <25ac; cleared; or light residential development
-  Unfragmented Block of natural land cover (labeled by total acres)
-  Ossipee River watershed

*coastal islands, dunes, and salt marsh not in map extent*

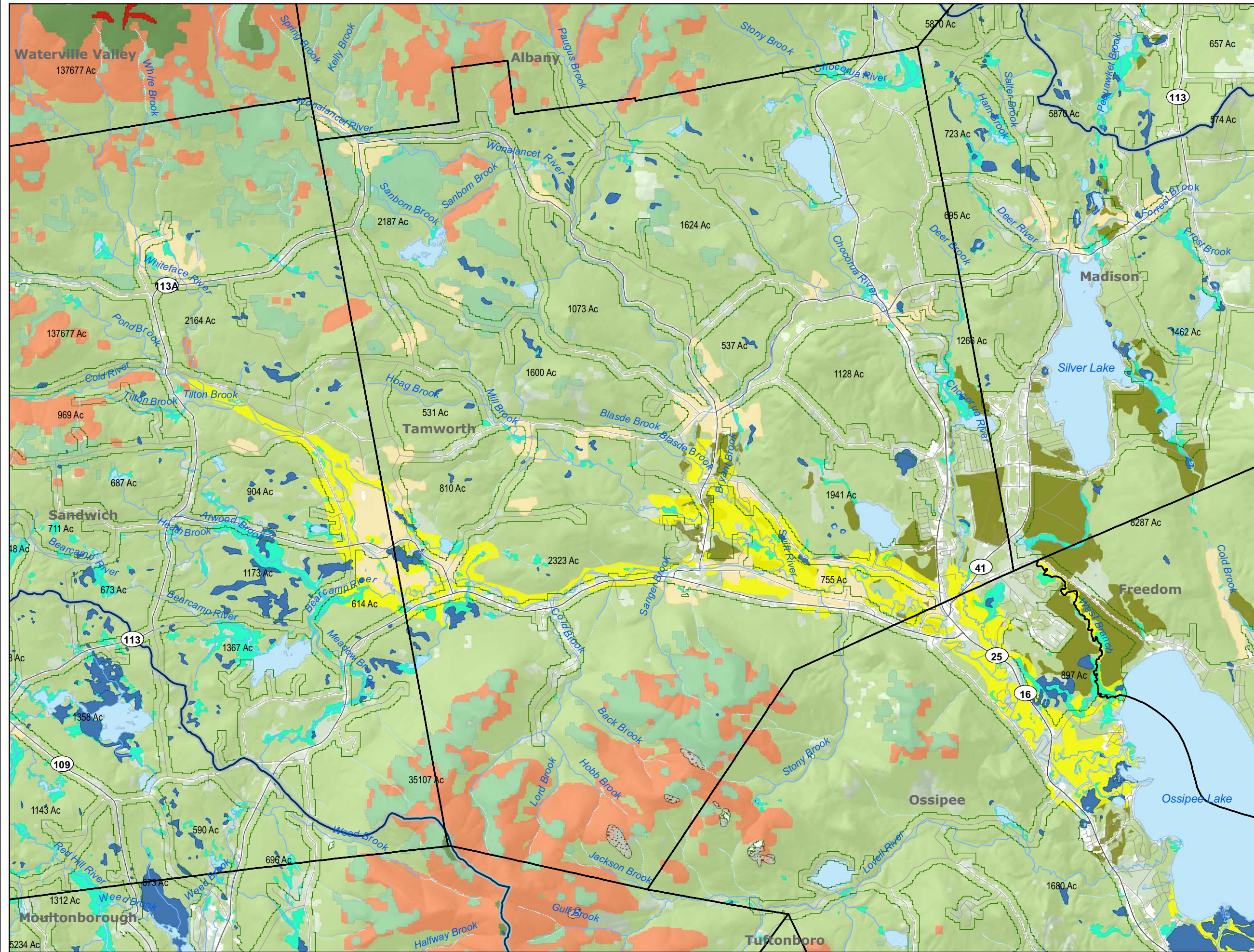

September 2007

