

Item No. _____



Arch Series

Self-Contained, dual temperature bunker merchandisers with sliding glass lids

microSC

The natural refrigerant case solution!

Advantages

- The natural refrigerant bunker case solution
- Sliding curved glass lids for maximum product visibility
- Dual temperature cases can be utilized for either frozen or refrigerated food applications
- Ice Cream certified (DOE)
- Environmentally-friendly R-290 natural refrigerant
- Self-contained 'Plug 'n Play' allows for quick setup and adaptation to floor plan changes

Key Features

- 120V electrical requirement
- Sound level is less than 55 dB
- Exterior and Interior Color Options: Black, Gray or White

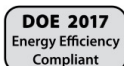

AIA # _____

Hussmann Corporation

12999 St. Charles Rock Rd.
Bridgeton, MO 63044-2483
Ph: 800.592.2060

www.hussmann.com

ARCH Series

Self-Contained, dual temperature bunker merchandisers with sliding glass lids

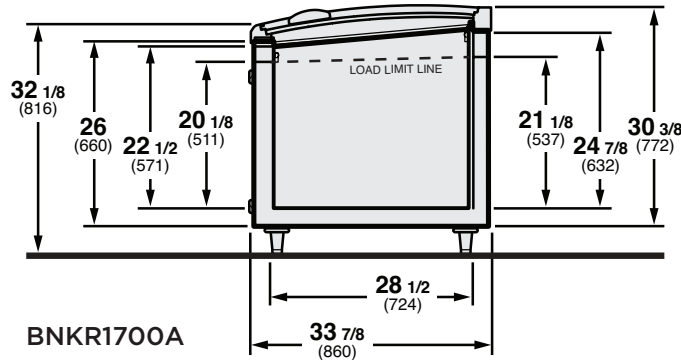

Dimensions shown as in. and (mm).

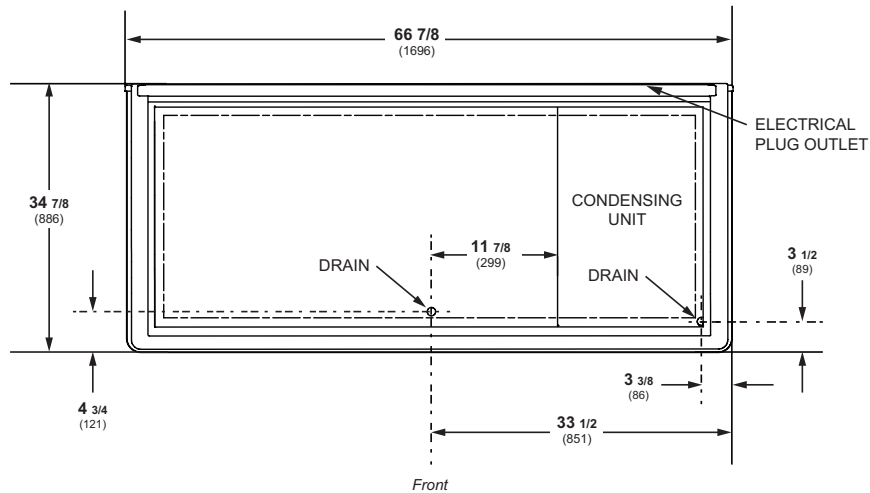

NOTE: This case has a drain pan and does not require a floor drain.

Model	L	D	H	Volume	In/Ex	Ref.	Volts	Run Amps	Noise	Cord Length	Weight	Env.
BNKR1700A	66-7/8" (1696)	34-7/8" (885)	32-1/8" (816)	3.37 sq ft	B/F	R290	120V	8.6	<55db	10'	276 (125kg)	NSF 7 TYPE II

AIA #

Bidding specifications

NEMA 5-15P



[DATA SHEET](#)

For more detailed information scan or click above.

We reserve the right to change or revise specifications and product design in connection with any feature of our products. Such changes do not entitle the buyer to corresponding changes, improvements, additions, or replacements for equipment previously sold or shipped. For additional resources, contact your representative or visit www.hussmann.com.



12999 St. Charles Rock Rd.
Bridgeton, MO 63044-2483
Ph: 800.592.2060

www.hussmann.com