

HGM-1, 2 & 3 BS, TS

*Bottom / Top Mount
Medium Temperature
Remote and Self Contained
Glass Door Merchandisers*



HGM-3BS



HGM-2TS

Installation & Operation Manual

IMPORTANT
Keep in store
for future reference!

P/N 0515297_E
June 2015

ATTENTION

Merchandiser must operate for 24 hours
before loading product!

Regularly check merchandiser temperatures.

Do not break the cold chain. Keep products
in cooler before loading into merchandiser.

These merchandisers are designed
for only pre-frozen products.



IMPORTANT
KEEP IN STORE FOR FUTURE REFERENCE
Quality that sets industry standards!

12999 St. Charles Rock Road • Bridgeton, MO 63044-2483

U.S. & Canada 1-800-922-1919 • Mexico 1-800-890-2900

www.hussmann.com

© 2015 Hussmann Corporation

TABLE OF CONTENTS

v

ANSI DEFINITIONS vi

INSTALLATION

Certification 1-1
Husmann Product Control 1-1
Shipping Damage 1-1
Location 1-1
Self Contained (Location) 1-2
Model Description 1-4
Unloading 1-4
Exterior Loading 1-4
Shipping Skid 1-4
Merchandiser Leveling 1-5
Leg Installation 1-5
Serial Plate Location 1-5
Refrigeration Unit Access 1-6
Sealing Merchandiser to Floor 1-5
Air Distribution & Rear Flue Spacer 1-6
Shelves 1-6

ELECTRICAL / REFRIGERATION

Merchandiser Electrical Data 2-1
Field Wiring 2-1
Electrical Connections 2-1
Electrical Outlet 2-1
Refrigeration (Self Contained) 2-1
Line Sizing (Remote Models) 2-2
 Oil Traps 2-2
 Pressure Drop 2-2
Water Outlet and Water Seal 2-2

START UP / OPERATION

Start-Up 3-1
Operation 3-1
 Power Switch 3-1
 Light Switch 3-1
 Electromechanical Control 3-1
Safe NET III User Instructions 3-2
Start-Up 3-3
Sequence of Operation 3-5
Temperature Adjustment 3-6
Alarms and Codes 3-6
Defrost Termination Switch 3-6

Manual Defrost 3-6
Temperature Adjustment 3-7
Sensor to Control Configuration 3-8
Lighting 3-9
LED Lights 3-9
Door Defrost Heater Thermostat 3-9
Controls and Adjustments 3-10
Refrigerant Control 3-10
Load Limits 3-11
Stocking 3-11
NOTES: 3-12

MAINTENANCE

Care and Cleaning 4-1
 Exterior Surfaces 4-1
 Interior Surfaces 4-1
Do NOT Use: 4-1
Do: 4-1
Cleaning Stainless Steel Surfaces 4-2
Cleaning Coils 4-2
Cleaning Evaporation Pan 4-3
NOTES: 4-4

SERVICE

Replacing Fan Motors and Blades 5-1
Replacing Thermometer 5-1
Trouble Shooting Guide 5-2
Replacing door parts 5-3
Servicing led lighting 5-3
Servicing flourescent lighting 5-3
Replacement parts 5-4

APPENDIX

Part Numbers A-1
HGM-1BS — Plan View A-2
HGM-2BS & HGM-2BS — Plan View.. A-3
HGM-1TS — Plan View A-4
HGM-2TS — Plan View A-5
HGM-3TS — Plan View A-6
Dimensions & Electrical Data A-7
Cross Sections and Refrigeration Data.. A-8
Wiring Diagram — Remote A-9

WARRANTY

REVISION HISTORY

REVISION E — Changed value of amps to 12.6, HGM-3BS TS Wiring Diagram, Page A-10

REVISION D — California Warning, Page 1-2, HGM-2BS location, Page 1-3

REVISION C — Changed NEMA plug, New Parts List, Updated Wiring Diagrams

REVISION B — Changed fonts and replaced revision level to B for Wind Chill

ORIGINAL ISSUE — JANUARY 2011

ANSI Z535.5 DEFINITIONS

 • **DANGER** – Indicate[s] a hazardous situation which, if not avoided, will result in death or serious injury.

 • **WARNING** – Indicate[s] a hazardous situation which, if not avoided, could result in death or serious injury.

 • **CAUTION** – Indicate[s] a hazardous situation which, if not avoided, could result in minor or moderate injury.

• **NOTICE** – *Not related to personal injury* – Indicates[s] situations, which if not avoided, could result in damage to equipment.

INSTALLATION

CERTIFICATION

These merchandisers are manufactured to meet ANSI / National Sanitation Foundation (NSF®) Standard #7 requirements. Proper installation is required to maintain certification. Near the serial plate, each case carries a label identifying the type of application for which the case was certified.

ANSI/NSF-7 Type I - Display Refrigerator / Freezer
Intended for 75°F / 55% RH Ambient Application

ANSI/NSF-7 Type II - Display Refrigerator / Freezer
Intended for 80°F / 55% RH Ambient Application

ANSI/NSF-7 - Display Refrigerator
Intended for Bulk Produce

HUSSMANN PRODUCT CONTROL

The serial number and shipping date of all equipment is recorded in Hussmann's files for warranty and replacement part purposes. All correspondence pertaining to warranty or parts ordering must include the serial number of each piece of equipment involved. This is to ensure the customer is provided with the correct parts.

SHIPPING DAMAGE

All equipment should be thoroughly examined for shipping damage before and during unloading. This equipment has been carefully inspected at our factory. Any claim for loss or damage must be made to the carrier. The carrier will provide any necessary inspection reports and/or claim forms.

Apparent Loss or Damage

If there is an obvious loss or damage, it must be noted on the freight bill or express receipt and signed by the carrier's agent; otherwise, carrier may refuse claim.

Concealed Loss or Damage

When loss or damage is not apparent until after equipment is uncrated, retain all packing materials and submit a written response to the carrier for inspection within 15 days.

LOCATION

These merchandisers are designed for displaying products in air conditioned stores where temperature is maintained at or below the ANSI / NSF-7 specified level and relative humidity is maintained at or below 55%.

**Recommended operating ambient
 temperature is between
 65°F (18°C) to 75°F (23.9°C).
 Maximum relative humidity is 55%.**

Placing refrigerated merchandisers in direct sunlight, near hot tables or near other heat sources could impair their efficiency. Like other merchandisers, these merchandisers are sensitive to air disturbances. Air currents passing around merchandisers will seriously impair their operation. Do NOT allow air conditioning, electric fans, open doors or windows, etc. to create air currents around the merchandiser.

1-2 INSTALLATION

For California Businesses:

⚠ WARNING
This product may contain chemicals known to the State of California to cause cancer, birth defects, or other reproductive harm.

This warning is the result of the California State law known as the California Safe Drinking Water and Toxic Enforcement Act of 1986, which is commonly referred to as “Proposition 65.”

This warning does not mean that Hussmann products will cause cancer or reproductive harm, or is in violation of any product-safety standards or requirements. As clarified by the California State government, Proposition 65 can be considered more of a ‘right to know’ law than a pure product safety law. When used as designed, Hussmann believes that our products are not harmful. We provide the Proposition 65 warning to stay in compliance with California State law. It is your responsibility to provide accurate Proposition 65 warning labels to your customers when necessary. For more information on Proposition 65, please visit the California State government website.

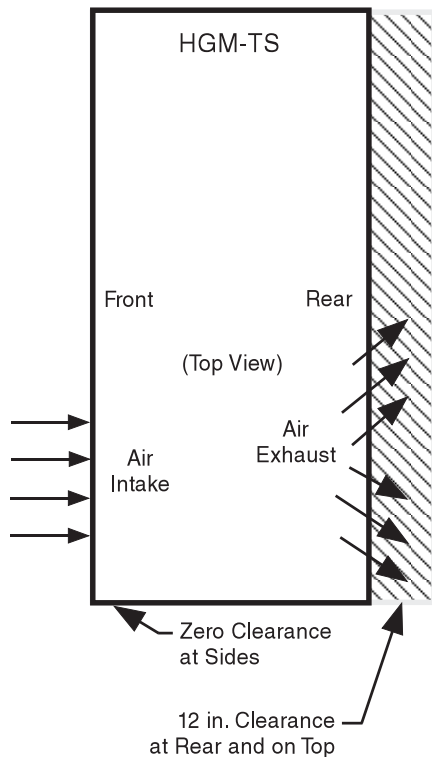

SELF CONTAINED (LOCATION)

Product should always be maintained at proper temperature. This means that from the time the product is received, through storage, preparation and display. The temperature of the product must be controlled to maximize the life of the product.

BE SURE TO POSITION SELF CONTAINED MERCHANDISERS PROPERLY.

HGM-TS Location

The condensing unit is located at the top of the HGM-TS. **At least 12 inches of clearance should be allowed at the rear of the cabinet and at the top of the merchandiser.** This clearance is necessary to provide free air movement to and from the condensing unit for maximum operating efficiency.

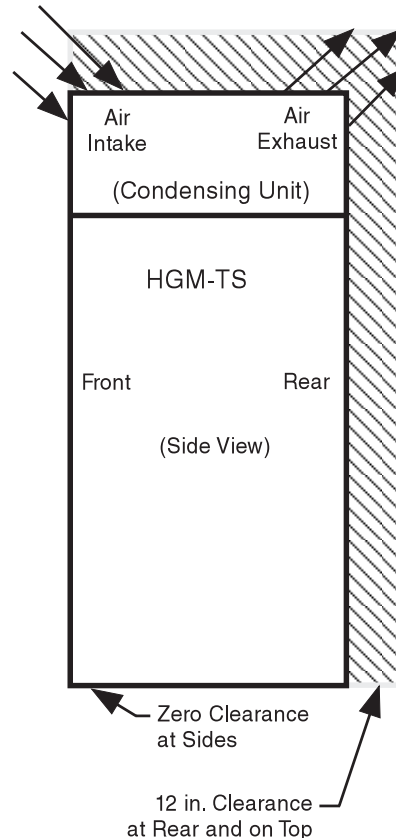

HGM-BS Location

At least 24 inches of clearance should be maintained in front of HGM-BS merchandisers and 6 inches of clearance at the rear to provide the necessary free air movement to and from the condensing unit. The condensing unit is located at the bottom of these merchandiser.

HGM-2BS merchandisers require the same clearance space, but the air flow is different as shown in the illustration at right. Avoid installing 1-door merchandisers on the left side of the case.

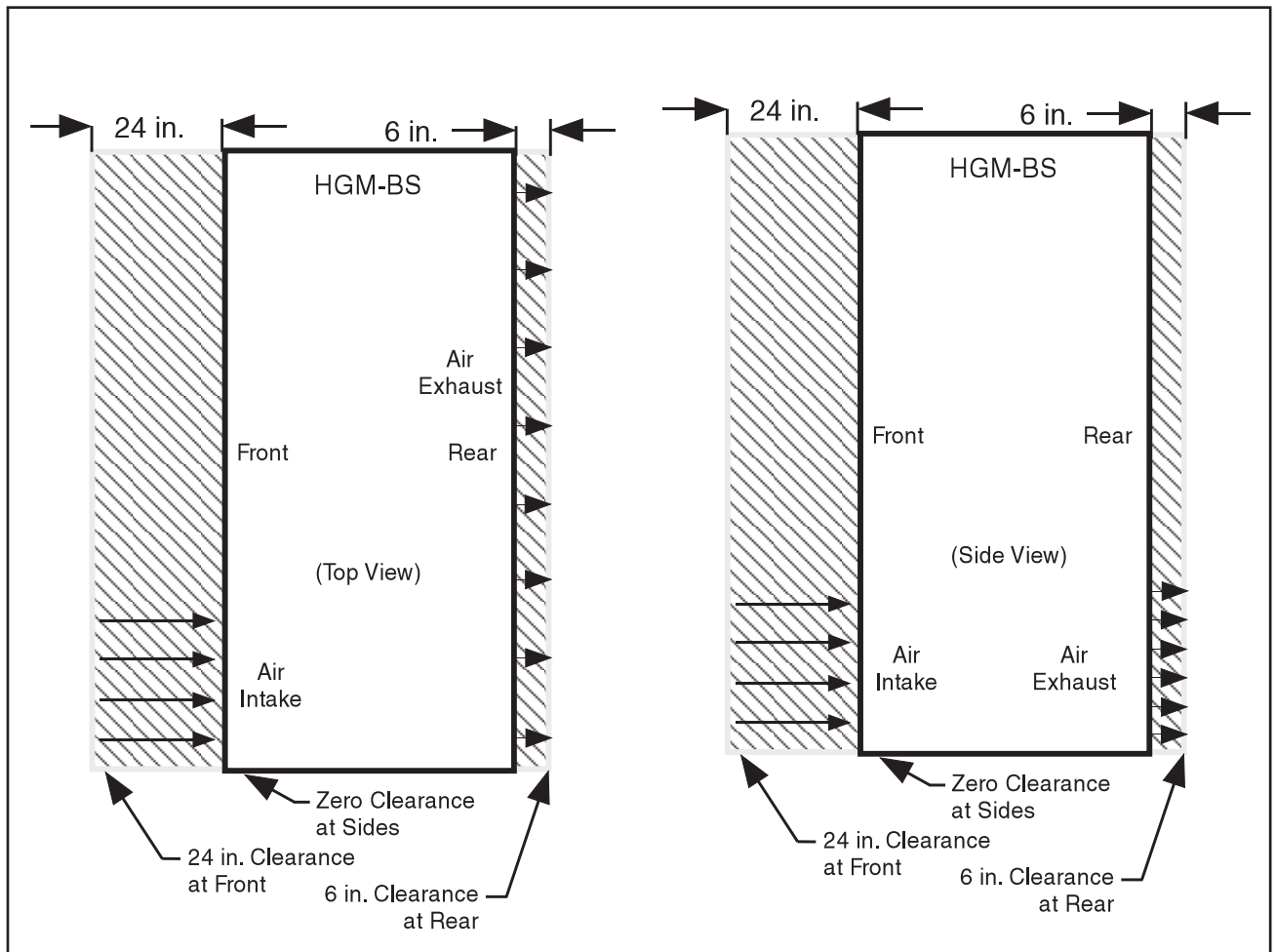
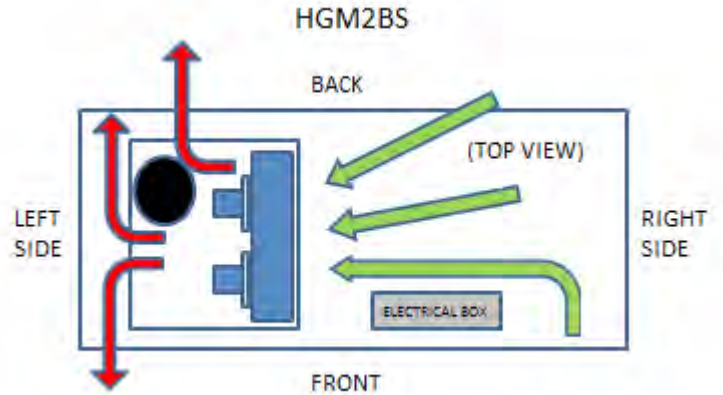

1-4 INSTALLATION

MODEL DESCRIPTION

The HGM-BS/TS models are self-contained, medium temperature, vertical glass door merchandisers designed for the display of dairy products, deli items and beverages. Design features include self-closing glass doors, efficient foamed in place non-CFC insulation and balanced R-134a refrigeration systems for energy saving performance.

UNLOADING

Unloading from Trailer:

Lever Bar (also known as a Mule, Johnson Bar, J-bar, Lever Dolly, or Pry Lever)

Move the merchandiser as close as possible to its permanent location and remove all packaging. Check for damage before discarding packaging. Remove all separately packed accessories such as kits and shelves.

Improper handling may cause damage to the merchandiser when unloading. To avoid damage:

1. Do not drag the merchandiser out of the trailer. Use a Johnson bar (mule).
2. Use a forklift or dolly to remove the merchandiser from the trailer.



WARNING

Do not store objects or flammable materials atop the unit.



WARNING

Do NOT remove shipping crate until the merchandiser is positioned for installation.

EXTERIOR LOADING

Do NOT walk on top of merchandisers or damage to the merchandisers and serious personal injury could occur.

MERCHANDISERS ARE NOT STRUCTURALLY DESIGNED TO SUPPORT EXCESSIVE EXTERNAL LOADING such as the weight of a person. Do not place heavy objects on the merchandiser.

SHIPPING SKID

Each merchandiser is shipped on a skid to protect the merchandiser's base, and to make positioning the case easier.

Remove the top of the crate and detach walls from each other. Lift crate from the skid. Unscrew the case from the skid. The fixture can now be lifted off the crate skid. **Lift only at base of skid!** Remove any braces and/or skids attached (blanket wrapped merchandiser may have skids).

DO NOT TILT MERCHANDISER ON ITS SIDE OR END WHEN REMOVING SKID.

Tilting merchandiser could cause damage to the refrigeration system.

Once the skid is removed, the merchandiser must be lifted —NOT PUSHED— to reposition. To remove the skid, remove screws attaching skid to the merchandiser.

Check floor where cases are to be set to see if it is a level area. Determine the highest part of the floor.

Unpack door and all packaged accessories.

MERCHANDISER LEVELING

BE SURE TO POSITION MERCHANDISERS PROPERLY. Level the merchandiser at corners.

Merchandiser(s) must be installed level to ensure proper operation of the refrigeration system and to ensure proper drainage of defrost water. The merchandiser can be leveled by shimming under the cabinet base frame, or by installing optional leg levelers.

The self-closing doors require the cabinet to be properly leveled. End to end leveling will allow the door(s) to close with uniform speed and tightness. A slight pitch from front to rear is desirable. THE BACK OF MERCHANDISER SHOULD NEVER BE HIGHER THAN THE FRONT.

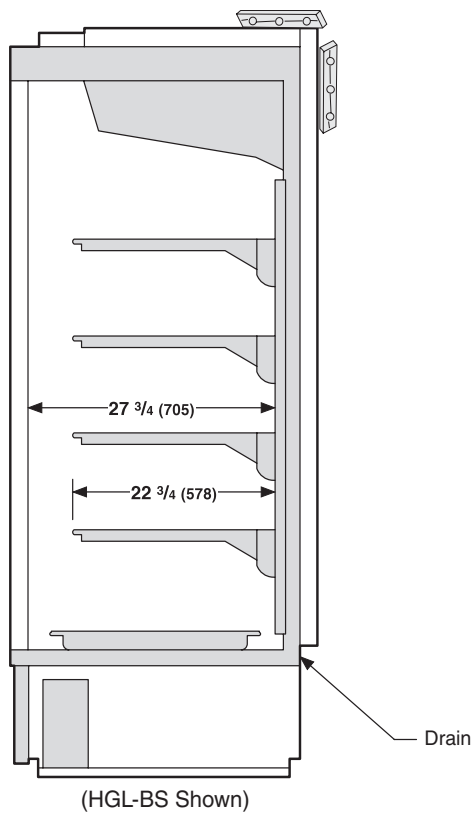

LEG INSTALLATION (Top Mounts Only)

Install the NSF approved legs after the case is near its final location. The legs are packaged inside the cabinet. Replace the tape and door blocks.

To install legs:

Raise one end of the cabinet about 8 inches. Block the merchandiser securely, and install two legs. The leg mounting plates are factory installed and contain a 1/2 x 13 in. tapped hole to mate with the leg assembly. The procedure is repeated on the opposite end. Three-door merchandisers require legs in the center.

The cabinet should now be positioned at its final location with all legs installed. The merchandiser is leveled by turning the bottom section of each leg. End to end leveling will make the door(s) close with uniform speed and tightness. A slight pitch from front to rear is desirable.

SERIAL PLATE LOCATION

The serial plate is located in the upper left-hand corner of the merchandiser's interior. The serial plate contains all pertinent information such as model, serial number, amperage rating, refrigerant type and charge. **Do not remove the serial plate under any circumstance.**

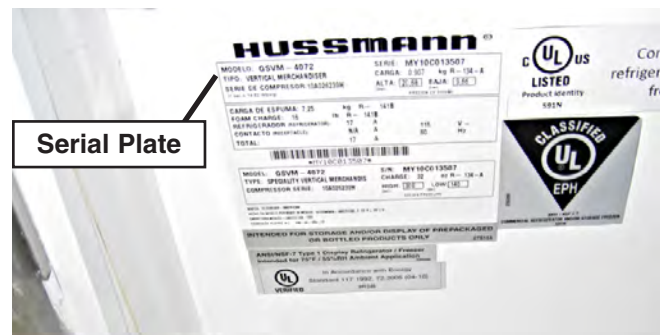

REFRIGERATION UNIT ACCESS

Top Mounts — The top decorative panel is removed by lifting the panel up and pulling forward.

Bottom Mounts — The lower front panel may be removed by removing screw at bottom and lifting the panel straight upward and over the tabs on which it is hanging. The panel is installed by reversing the above procedure.

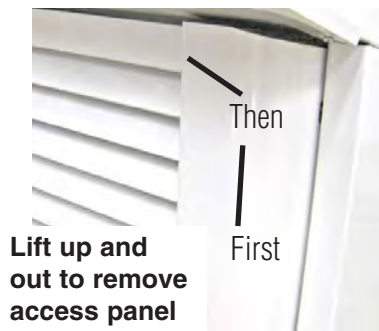

Ensure lower front panel is flat against the floor when installed to prevent air circulation problems for self contained merchandisers. If the condensing unit needs to be serviced, it can be pulled out to gain access for hard to reach components like the condenser fans. To pull out the condensing unit, remove the two hold down brackets at the unit base.

Care must be given to the drain line when replacing the condensing unit into the case. The drain line must be inside the defrost water evaporation pan to prevent the discharge of water on the floor.

SEALING MERCHANDISER TO FLOOR (Bottom Mounts Only)

If required by local sanitary codes, or if the customer desires, merchandisers may be sealed to the floor using a vinyl cove base trim. The size needed will depend on how much variation there is in the floor, from one end of the merchandiser to the other. Sealing of the lower

front and rear panels on self contained models may hamper their removal for servicing or maintenance of the condensing unit.

NOTE: Do not allow trim to cover any intake or discharge grilles located in the lower front panel.

AIR DISTRIBUTION & REAR FLUE SPACER

Air is drawn through the evaporator from front to rear and is discharged down the back wall, returning up the face of the glass door to the return air grille.

NOTE: Rear flue spacer must be in place as this forms a discharge air flue at the back of the cabinet.

SHELVES

Each cabinet is provided with four cantilever shelves per door that are adjustable by 1 inch increments. The shelves can also be tilted. Each cabinet has one bottom shelf per door. These shelves have one-inch legs to allow proper air flow in the cabinet. Behind the shelves are wire flue spacers, which allow for proper air flow. All shelves and flue spacers are white and epoxy coated for durability and ease of cleaning. Shelves should be adjusted to desired operating height. Do not load product so that it touches the evaporator coil cover. Do not extend product past the front edge of the shelf. Extending past the edge will seriously affect internal air flow through the cabinet.

Shelves are UL rated for a maximum load of 120 lbs. **DO NOT OVERLOAD THE SHELVES.**

Hussmann Self-Contained Refrigeration Equipment Start Up Check List

Please note that failure to follow this start-up document may void your factory warranty

Step	Startup Activity	Check
1	Locate, read and maintain install/operation manual in a safe place for future reference.	<input type="checkbox"/>
2	Examine unit. Confirm there is NO damage or concealed damage.	<input type="checkbox"/>
3	Level the unit, side to side and front to rear.	<input type="checkbox"/>
4	Remove all shipping brackets/compressor straps/bolts etc.	<input type="checkbox"/>
5	Unit must be run on a dedicated electrical circuit without the use of an extension cord.	<input type="checkbox"/>
6	Ensure that the proper electrical requirements for the equipment are supplied.	<input type="checkbox"/>
7	Verify field electrical connections are tight.	<input type="checkbox"/>
8	Verify all electrical wiring is secured and clear of any sharp edges or hot lines.	<input type="checkbox"/>
9	Verify the condensate drain line is properly trapped and pitched.	<input type="checkbox"/>
10	Verify all required clearances on the sides and back of unit.	<input type="checkbox"/>
11	Verify there are no air disturbances external to the unit. Heat and air registers, fans, and doors etc.	<input type="checkbox"/>
<p>Advise owner/operator that merchandiser must operate at temperature for 24 hrs prior to loading with product.</p>		

Form HSCW01 Rev. 30MAY12 P/N 0525209_B

LEGAL DISCLAIMER:

Hussmann shall not be liable for any repair or replacements made without the written consent of Hussmann, or when the product is installed or operated in a manner contrary to the printed instructions covering installation and service which accompanied such product.

ELECTRICAL / REFRIGERATION

MERCHANDISER ELECTRICAL DATA

Refer to Appendix A of this manual or the merchandiser's serial plate for electrical information.

FIELD WIRING

Field wiring must be sized for component amperes stamped on the serial plate. Actual ampere draw may be less than specified.

ALWAYS CHECK THE SERIAL PLATE FOR COMPONENT AMPERES

ELECTRICAL CONNECTIONS

All wiring must be in compliance with NEC and local codes. All electrical connections (*for the HGM remote models*) are to be made in the electrical *Handy Box* located behind the removable base panel at the right end of the merchandiser when facing the discharge honeycomb. The cabinet supply breakers should be disconnected before removing the enclosure cover.

ELECTRICAL OUTLET:

Before the merchandiser is connected to any wall circuit, use a voltmeter to check that the outlet is within the recommended voltage limits:

Nominal Volts	120V
Minimum Volts	108V
Maximum Volts	132V

The wall circuit must be dedicated for the merchandiser. Failure to do so voids the warranty. **Do not use an extension cord.** Never plug in more than one merchandiser per electrical circuit.

- Always use a dedicated circuit with the amperage stated on the unit.
- Plug into an outlet designed for the plug.
- Do not overload the circuit
- Do not use long or thin extension cords. Never use adapters.
- If in doubt, call an electrician.

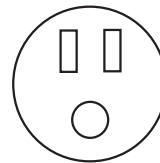

NEMA 5-15P
HGM-1, 2 BS/TS

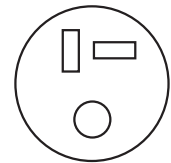

NEMA 5-20P
HGM-3 BS/TS

All HGM models are supplied with a power cord and grounding prong for operation on a 115V power supply.

REFRIGERATION (Self Contained Models)

Each self contained model is equipped with its own condensing unit and control panel located beneath the display area. The correct type of refrigerant will be stamped on each merchandiser's serial plate. The merchandiser refrigeration piping is leak tested. The unit is charged with refrigerant, and shipped from the factory with all service valves open.

**WARNING**

Risk of Electric Shock. If cord or plug becomes damaged, replace only with a cord and plug of the same type.

**WARNING**

Merchandiser must be grounded. Do not remove the power supply cord ground.

LINE SIZING**(Remote Models)**

Refrigerant line connections are made at the right end of merchandiser (facing front) beneath the refrigerated display area. The refrigerant line connection size is $\frac{3}{8}$ in. The suction line is $\frac{5}{8}$ in. Refrigerant lines should be sized as shown on the refrigeration legend that is furnished for the store or according to ASHRAE guidelines.

Oil Traps

P-traps (oil traps) must be installed at the base of all suction line vertical risers.

Pressure Drop

Keep refrigerant line runs as short as possible to avoid large pressure drops. Use a minimum number of elbows. Where elbows are required, **USE LONG RADIUS ELBOWS ONLY.**

**CAUTION**

When brazing pipes, be sure to use the insulation blanket shipped with the merchandiser to prevent damage to the metal merchandiser bottom.

**WARNING**

Refrigeration lines are under pressure. Refrigerant must be recovered before attempting any connection or repair.

WATER OUTLET AND WATER SEAL

The cabinet is provided with a factory installed outlet for defrost water. It runs from the bottom of the display area to an evaporation pan near the condenser unit.

The outlet is not connected to the waste water system for washing out the cabinet. This system is designed to evaporate normal condensate. This system should be checked regularly, especially during high relative humidity conditions, to verify the condensate tube is not blocked, and that the pan does not accumulate too much water which could spill out on the floor.

**WARNING**

— LOCK OUT / TAG OUT —

To avoid serious injury or death from electrical shock, always disconnect the electrical power at the main disconnect when servicing or replacing any electrical component. This includes, but is not limited to, such items as doors, lights, fans, heaters, and thermostats.

**WARNING**

Product will be degraded and may spoil if allowed to sit in a non-refrigerated area.

START UP / OPERATION

START UP

1. Check the cabinet thoroughly for loose nuts and bolts and electrical connections. Inspect the refrigeration lines for any visible damage or chafing.
2. Replace the electrical box cover.
3. Start the merchandiser and allow the merchandiser to pull down to operating temperature.

The merchandiser must operate for 24 hours before loading product. Regularly check temperatures. Do not break the cold chain. Keep products in cooler before loading merchandiser. These merchandisers are designed for pre-chilled product only.



WARNING

Product will be degraded and may spoil if allowed to sit in a non-refrigerated area.

Under normal conditions, after the cabinet is installed and running, very little maintenance should be required. Follow the list of instruction below after initial startup and for periodic maintenance purposes.

1. Check operation of condenser fan motors. Fan blades must turn freely.
2. Check drain pan and heater to prevent accidental overflow.
3. Make sure doors are closing properly and that the gaskets seal.
4. Make sure all evaporator fan motors are running. These can be seen through the grille inside the cabinet.

OPERATION

Power Switch

The power switch is located at the electrical box behind the top, decorative panel (TS models) or bottom louvered panel (BS models). The switch will shut off all power to the merchandiser.

Light Switch

Each HGM model has a convenient ON/OFF switch so lights may be turned off to conserve energy during hours when the store is closed. The switch only controls the lights.



...ATTENTION
INSTALLER

It is the contractor's responsibility to install merchandiser(s) in accordance with all local building and health codes.

START UP / OPERATION



SAFE-NET III™ USER INSTRUCTIONS

Your refrigerated case uses a Husmann Safe-NET™ III temperature and defrost controller to precisely maintain the temperature and prevent frost buildup on the cooling coil. LEDs indicate when the compressor or refrigeration is on, when the case is in a defrost cycle, if the temperature is outside the desired range, or if there is a sensor failure.

An adjustment knob allows the temperature to be set within the configured range and can power off the controller and compressor. Your controller has been custom-configured to provide the best temperature and defrost control for your chilled or frozen food.

The front of the controller has an adjustment knob and status LEDs. The back of the controller has connections for sensors and switched equipment.

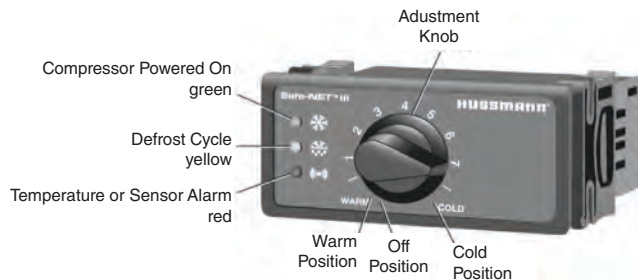

The Safe-NET III controller includes the following features and connections.

- Adjustment knob:
Adjusts the temperature setpoint. Turn adjustment knob to OFF to turn off refrigeration system. Unplug merchandiser from power before servicing the unit.

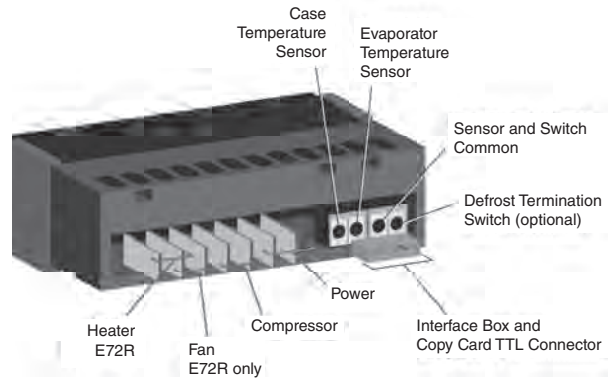

- Controller LEDs:
 - ❄️ Compressor Powered On LED (green):
Lights while the compressor is running or the refrigeration valve is open.
 - ❄️ Defrost Cycle LED (yellow):
Lights while the refrigeration coil is defrosting.
 - 🔊 Temperature or Sensor Alarm (red):
Lights if the temperature is too warm or too cold. Flashes if a sensor fails.

- Rear connections:
 - Case temperature sensor:
 - Typically senses the temperature of the air in the case.
Used by the controller to determine when to power on or power off the compressor or refrigeration.
 - Compressor or refrigeration relay:
 - Switches on the compressor or refrigeration valve for cooling.



WARNING

The optional evaporator fan remains ON when the adjustment knob is in the Off position.

DISPLAY

The display includes three red LEDs and two digits for temperature, defrost status, and error codes.

The three display LEDs are red, and their behavior matches the LEDs on the controller.



START-UP

Before applying power to the merchandiser, remove the front grille.

Check thermostat knob is at the appropriate position. See temperature adjustment on Page 3-6.

Check the check the merchandiser's cabinet thoroughly for loose nuts and bolts. Check all electrical connections. Inspect the refrigerant lines for any visible damage or chafing.

Replace the front grille.

The following list of housekeeping practices will assure trouble-free operation:

- Check operation of condenser fan motors. Fan blades must turn freely.
- Check drain pan and heater to prevent accidental overflow.
- Make sure doors are closing properly, and that gaskets are sealed.
- Make sure all evaporator fan motors are running. These can be seen through grille inside of cabinet.

1. Plug in the merchandiser.



WARNING

The OFF Position does not disconnect line voltage to the case, refrigeration unit, fan, or heater.

2. Wait for the self check to complete. During the self check, each LED flashes for one second, then all LEDs turn on for two seconds. If the LEDs do not flash, make sure the adjustment knob is not in the Off position.

- After the self check, all LEDs turn off until the compressor starts. **There may be a delay before the compressor starts.** If the red Temperature or Sensor Alarm LED stays on after the self check.
- The green Compressor Powered On LED turns on when the compressor starts.

NOTE: Do NOT load product until AFTER merchandiser operates for 24 hours and reaches desired operating temperature.

Safe-NET parameter code is 58.



WARNING

Product will be degraded and may spoil if allowed to sit in a non-refrigerated area.

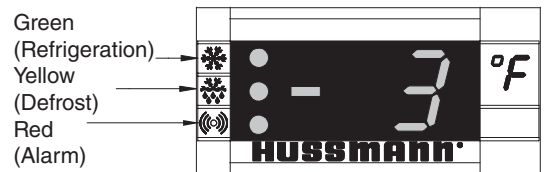
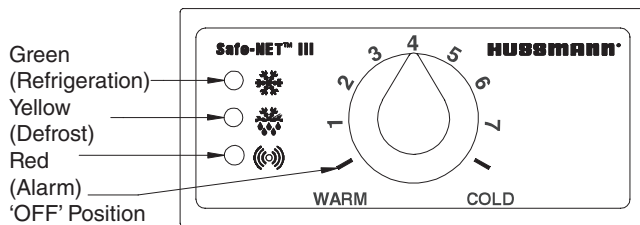
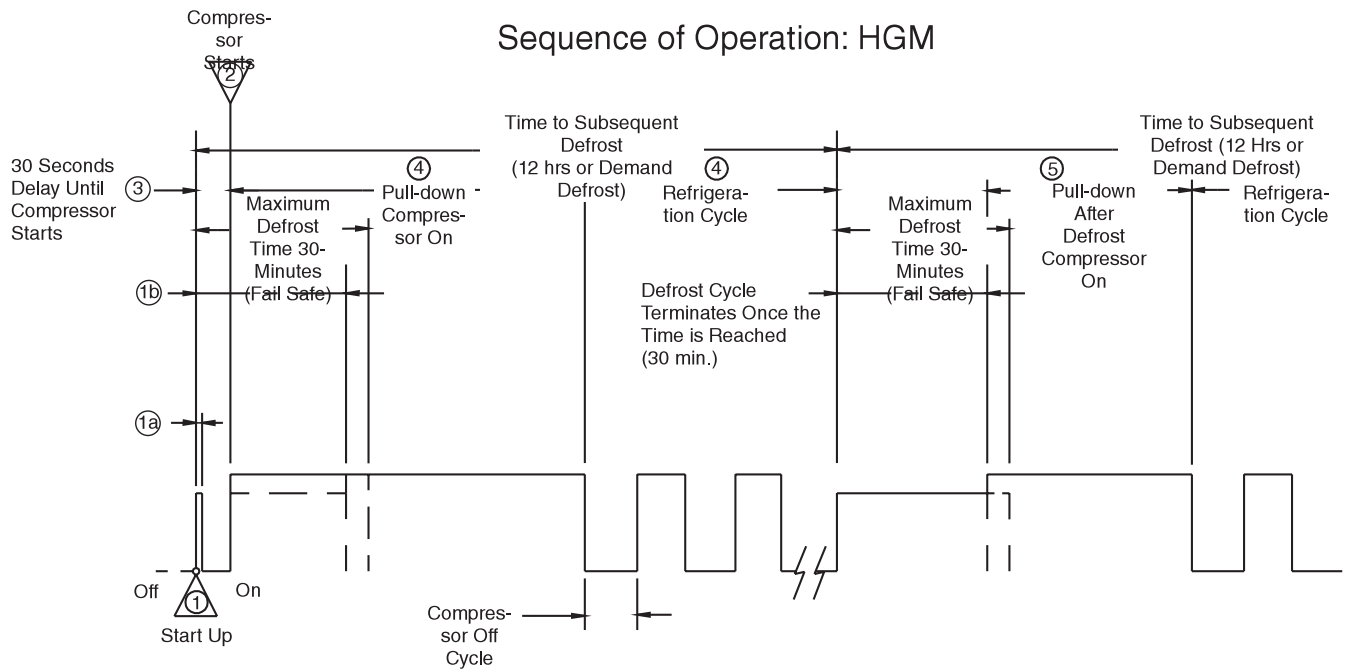

1. During the self check a 2 digit number will appear for 3 seconds. Then each LED flashed for one second and then all LED's turn on for two seconds. If the LED's do not flash, make sure the adjustment knob is not in the "OFF" position.
2. The compressor will start after a delay; 30 seconds after the power is applied.
3. The compressor will continue to run until it reaches its cut-out temperature (pull down).
4. The refrigeration cycle will continue until the next scheduled defrost (12 hours).
5. The above process will repeat (steps 3 and 4) until the power is interrupted.
6. If power stops, the process will start over at Step 1, and the time to subsequent defrost will reset.

TEMPERATURE ADJUSTMENT

Rotate the adjustment knob counter clockwise for a warmer setpoint or clockwise for a colder setpoint.

- While the temperature is being adjusted, the optional display shows the setpoint (cut out value). The display reverts to showing the sensed temperature in the merchandiser a few seconds after the temperature is set.

ALARMS AND CODES

FLASHING TEMPERATURE OR SENSOR ALARM LED, E1 OR E2

If the Temperature or Sensor Alarm LED (red) on the controller and display is flashing, a temperature sensor has failed. The display shows E1 if the case sensor has failed or E2 if the evaporator sensor has failed.

If the merchandiser sensor fails, refrigeration will run continuously. Turn off, or repeat a duty cycle of a few minutes on and a few minutes off.

DEFROST TERMINATION SWITCH

Merchandisers may use a defrost termination switch, instead of an evaporator sensor to terminate a defrost cycle. The defrost termination switch is temperature activated and senses the completion of defrost.

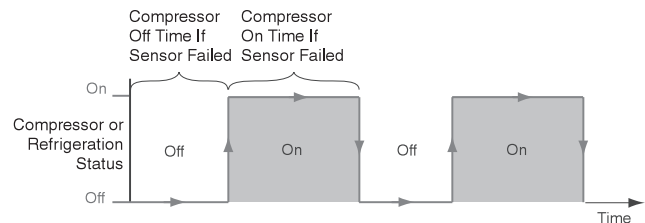

MANUAL DEFROST

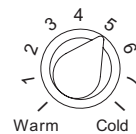

1. Note location of knob setting

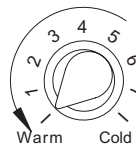

2. Rotate knob fully counterclockwise until it stops (full warm - "OFF" position)

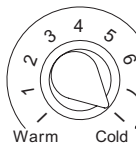

3. After 10 seconds, but before 20 seconds, rotate knob fully clockwise until it stops (full cold position)

Note:

This procedure initiates a manual or forced defrost.

IMPORTANT: Return the control knob to its original setting (Step 1) once the manual defrost has been initiated.

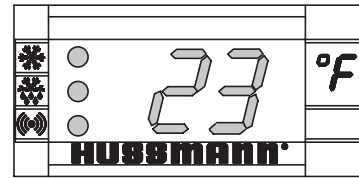
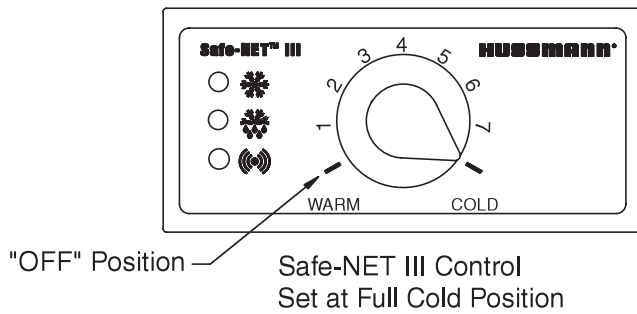

Display - at Full Cold Model HGM

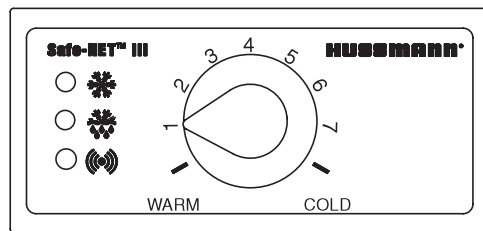

Safe-NET III Control # 1 Position

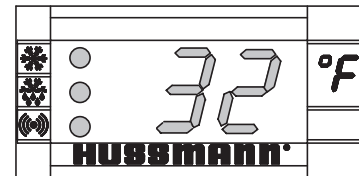

Display - at #1 Position Model HGM

TEMPERATURE ADJUSTMENT

1. Rotate the adjustment knob counter clockwise for a warmer setpoint or clockwise for a colder setpoint.
2. While adjusting the temperature, the display shows the setpoint (cut out value). A few seconds after the temperature is set, the controller reverts to the sensed temperature in the merchandiser.
3. To verify merchandiser settings, perform the operations below. Output readings should be within one degree of the temperatures shown above.

The control has protective settings to prevent short cycling of the compressor.

- A. The compressor may run for up to 3 min. after Step 2 is completed. Start the 10 sec. count down for Step 3, once the display is blank.
- B. The defrost initiation may be delayed for up to 6 min. after Step 3 is completed.

The display will show the temperature prior to defrost once Step 3 is completed, even with the protective delay timing out. The temperature will be locked for 1 hour after defrost has terminated to allow the temperature to stabilize.

Sensor to Control Configuration

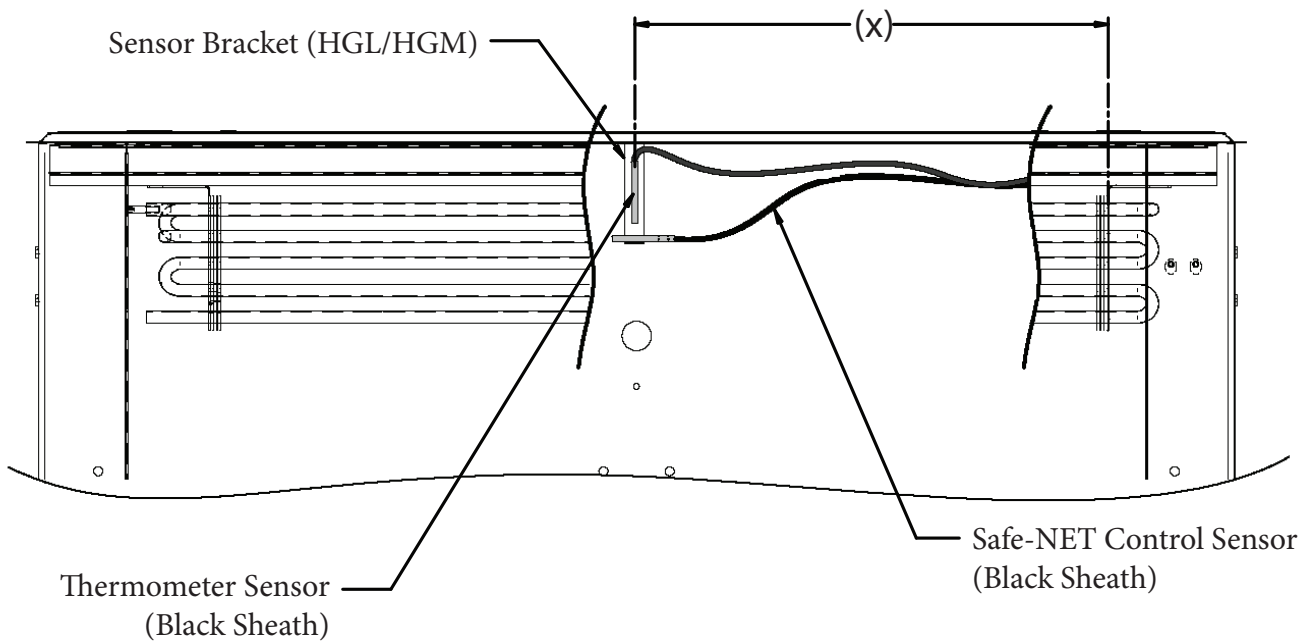

#8 Air Sensor
(Black Sheathed)
Black Wire

#9
Not Used

#10 Sensor
(Black Sheathed)
White Wire

#11
Not Used

Back of Safe-NET
Control Detail

LIGHTING

Each HGM model has an ON/OFF switch so lights may be turned off to conserve energy during hours when the store is closed. The switch is located inside the cabinet above the left-hand door. Power (115 V) must be shut off at the main disconnect, located within the store prior to starting any service or maintenance work.

LED LIGHTS

LED lights are optional features. For details showing how the LED fixtures are mounted, see the supplemental document shipped with the merchandiser.

DOOR DEFROST HEATER THERMOSTAT

This cabinet is equipped with both frame and door heaters. These are thermostatically controlled, and will not come on until the cabinet is at operating temperature.



It is the contractor's responsibility to install merchandiser(s) in accordance with all local building and health codes.



The OFF Position does not disconnect line voltage to the case, refrigeration unit, fan, or heater.



— LOCK OUT / TAG OUT —

To avoid serious injury or death from electrical shock, always disconnect the electrical power at the main disconnect when servicing or replacing any electrical component. This includes, but is not limited to, such items as doors, lights, fans, heaters, and thermostats.

CONTROLS and ADJUSTMENTS

Refrigeration Controls			Defrost Controls			
Model	Product Application	Discharge Air Temperature	Defrost Frequency (per day)	Type of Defrost	Termination Temperature	Failsafe Time (Minutes)
HGM Self Contained and remote	Medium Temp	28 F to 36 F	2	OFF CYCLE	48 F	30

CONTROLS AND ADJUSTMENTS

See table above for merchandiser operation.

If an attempt to clear the restriction by this method are unsuccessful, the entire assembly, not the capillary tube only, should be replaced with a new factory ordered replacement.

REFRIGERANT CONTROL

Refrigerant flow to the evaporator is controlled through the use of a capillary tube. Because the suction line capillary tube assembly, sometimes referred to as heat exchanger or pull-out coil has no moving parts, it will rarely need servicing. However, if a leak occurs in the refrigeration system, it is possibly that dirt, dust, or moisture may collect in the capillary tube causing the system to go into a vacuum. Should this occur, it is recommended that dry nitrogen or a dry refrigerant be forced through the system to clear blockage.

LOAD LIMITS

Each merchandiser has a load limit decal. Shelf life of perishables will be short if load limit is violated.



AT NO TIME SHOULD MERCHANDISERS BE STOCKED BEYOND THE LOAD LIMITS INDICATED.

STOCKING

Product should NOT be placed inside the merchandisers until merchandisers are at proper operating temperature.

Allow merchandiser 24 hours to operate before loading product.

Proper rotation of product during stocking is necessary to prevent product loss. Always bring the oldest product to the front and set the newest to the back.

AIR DISCHARGE AND RETURN FLUES MUST REMAIN OPEN AND FREE OF OBSTRUCTION AT ALL TIMES to provide proper refrigeration and air curtain performance. Do not allow product, packages, signs, etc. to block these grilles. Do not use non-approved shelving, baskets, display racks, or any accessory that could hamper air curtain performance.

Do not allow product to be placed outside of the designated load limits in the illustration.

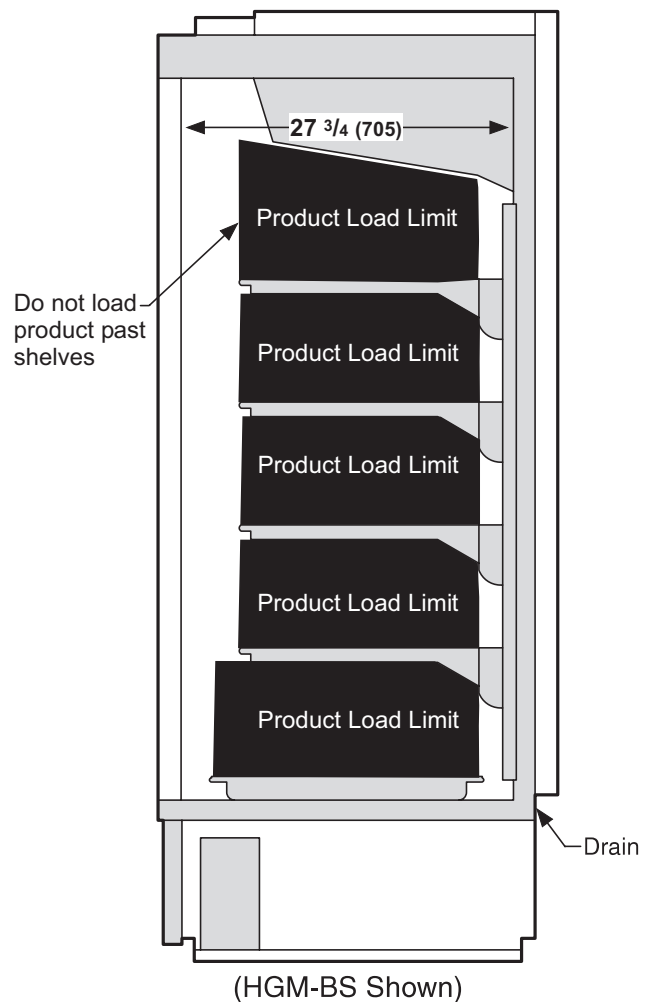

NOTES:

MAINTENANCE

CARE AND CLEANING

Long life and satisfactory performance of any equipment is dependent upon the care it receives. To ensure long life, proper sanitation and minimum maintenance costs, these merchandisers should be thoroughly cleaned, all debris removed and the interiors washed down, weekly.

Exterior Surfaces

The exterior surfaces must be cleaned with a mild detergent and warm water to protect and maintain their attractive finish. **NEVER USE ABRASIVE CLEANSERS OR SCOURING PADS.**

Interior Surfaces

The interior surfaces may be cleaned with most domestic detergents, ammonia based cleaners and sanitizing solutions with no harm to the surface. Self contained models empty into a limited capacity evaporation pan, which will overflow if excess water is used in cleaning.

Do NOT Use:

- Abrasive cleansers and scouring pads, as these will mar the finish.
- Coarse paper towels on coated glass.
- Ammonia-based cleaners on acrylic parts.
- Solvent, oil or acidic based cleaners on any interior surfaces.
- Do not use high pressure water hoses.



WARNING

Product will be degraded and may spoil if allowed to sit in a non-refrigerated area.

Do:

- Remove the product and all loose debris to avoid clogging the waste outlet.
- Store product in a refrigerated area such as a cooler. Remove only as much product as can be taken to the cooler in a timely manner.
- Disconnect electrical power before cleaning.**
- Thoroughly clean all surfaces with soap and hot water. **DO NOT USE STEAM OR HIGH WATER PRESSURE HOSES TO WASH THE INTERIOR. THESE WILL DESTROY THE MERCHANDISERS' SEALING CAUSING LEAKS AND POOR PERFORMANCE.**
- Take care to minimize direct contact between fan motors and cleaning or rinse water.
- Do NOT flood merchandiser with water. **NEVER INTRODUCE WATER FASTER THAN THE WASTE OUTLET CAN REMOVE IT.**



WARNING

Do NOT allow cleaning agent or cloth to contact food product.

SELF CONTAINED MODELS EMPTY INTO A CONDENSATE EVAPORATION PAN THAT WILL OVERFLOW IF TOO MUCH WATER IS INTRODUCED DURING CLEANING.

- Allow merchandisers to dry before resuming operation.
- After cleaning is completed, turn on power to the merchandiser.

CLEANING STAINLESS STEEL SURFACES

Use non-abrasive cleaning materials, and always polish with grain of the steel. Use warm water or add a mild detergent to the water and apply with a cloth. Always wipe rails dry after wetting.

Use alkaline chlorinated or non-chlorine containing cleaners such as window cleaners and mild detergents. Do not use cleaners containing salts as this may cause pitting and rusting of the stainless steel finish. Do not use bleach.

WARNING

**SHUT FANS OFF DURING
CLEANING PROCESS.**

WARNING

— LOCK OUT / TAG OUT —

To avoid serious injury or death from electrical shock, always disconnect the electrical power at the main disconnect when servicing or replacing any electrical component. This includes, but is not limited to, such items as doors, lights, fans, heaters, and thermostats.

CAUTION

Do NOT use HOT water on Cold glass Surfaces. This can cause the glass to shatter and could result in personal injury. Allow glass fronts, to warm before applying hot water.

CLEANING COILS

The condenser can be inspected without pulling the whole condensing unit out of the case. Simply remove the grille on the intake side of the condensing unit for HGM-BS merchandisers. For HGM-TS, the condensing unit is located at the top of the merchandiser.

Condenser coils should be cleaned at least once per month. Additional cleaning may be needed depending on the operational environment. A dirty condenser blocks normal airflow through the coils.

Airflow blockage increases energy consumption and reduces the merchandiser's ability to maintain operating temperature.

To clean the coils, use a vacuum cleaner with a wand attachment and a soft (non-metallic) brush to remove dirt and debris. Do not bend coil fins. Always wear gloves and protective eye wear when cleaning near sharp coil fins and dust particles.



Fin Coils

CLEANING EVAPORATION PAN

The condensate water outlet empties into a limited capacity evaporation pan.

Debris or dirt accumulation inside the condensate evaporation pan or on the heater coil will reduce the pan's evaporation capacity and cause premature heater failure. The evaporation pan waste water will overflow and spill onto the floor if the heater is not properly operating.

Always wear protective eye glasses and gloves when servicing.

Remove accumulated debris from the evaporation pan. Wipe down heater coil with a cloth and warm water. Be sure to remove any dirt, debris or liquids from the heater coil.

Water introduced during cleaning will cause the evaporation pan to overflow.

WARNING

Evaporation Pan is Hot!
and poses risk of bodily injury – Always Wear gloves and protective eye wear when servicing. Turn off evaporation pan heater, and allow pan to cool.



CAUTION

DO NOT FLOOD!
Use only enough water necessary to clean surface. Water must not drip down the case!
Never use ammonia based cleansers, abrasive cleansers, or scouring pads.



PRECAUTION CLEANING PRECAUTIONS

When Cleaning:

- Do not use high pressure water hoses
- Do not introduce water faster than waste outlet can drain
- NEVER INTRODUCE WATER ON SELF CONTAINED UNIT WITH AN EVAPORATION PAN
- NEVER USE A CLEANING OR SANITIZING SOLUTION THAT HAS OIL BASE (these will dissolve the butyl sealants) or and AMMONIA BASE (this will corrode the copper components of the merchandiser)
- TO PRESERVE THE ATTRACTIVE FINISH:
 - Use a water and a mild detergent for the exterior only
 - Do NOT use a chlorinated cleaner on any surface
 - Do NOT use abrasives or steel wool scouring pads (these will mar the finish)

Self-Contained Refrigeration Equipment Maintenance Check List

***** Warranty does not cover issues caused by improper installation or lack of basic preventative maintenance. *****

Record starting date	
Store Name and Number	
Store Address	
Unit Model Number	
Unit Serial Number	
Contractor/Technician	

	Technician										
	PM date										

PM activity-For visual inspection items, denote "ok or complete" in the column to right when PM has been performed. For measured data requested, record data requested in the appropriate column to the right)	Technician		PM date				PM date				
	Quarterly	Semi-Annually	Q1	Q2	Q3	Q4	Q1	Q2	Q3	Q4	
Check in with store manager, record any complaints or issues they have with unit.	X										
Look unit over for any damage, vibrations or abnormal noise.	X										
Verify unit is level side to side and front to rear.	X										
Confirm refrigerant lines properly are secured and not touching or rubbing other lines, wires or frame work.	X										
Verify fan motors and motor mounts are tight.	X										
Confirm fan blade/s are tight and not rubbing or hitting.	X										
Make sure all electrical connections, factory and field, are tight.	X										
Verify electrical connections at lamps are they secure and dry.	X										
Check for and replace any frayed or chaffed wiring.	X										
Check all electrical wiring make sure it is secured and not on any sharp edges or hot lines.	X										
Check for air disturbances external to the unit. Heat and air registers, fans, and doors etc.	X										
Check for water leaks.	X										
Clean evaporator coil/s and fan blade/s. Do not use an acid base cleaner. Rinse off any cleaner residue.		X									
Clean discharge air honeycombs or grilles. Do not use an acid base cleaner. Rinse off any cleaner residue.		X									
Clean condenser coil/s and fan blade/s. Do not use an acid base Cleaner. Rinse off any cleaner residue.		X									
Clean condensate drain pan and drain line.		X									
Verify condensate drain lines are clear and functioning.		X									
Record voltage reading at unit with unit off?		X									
Verify condenser and evaporator fans are working.	X										
Record condenser air inlet temperature	X										
Record condenser air outlet temperature	X										
Is condenser air inlet or air exhaust restricted or recirculating?	X										
Verify there are no visual oil or refrigerant leaks.	X										
Record voltage reading with unit running.		X									
Record compressor amp draw.		X									
Record defrost heater voltage and amp draw.		X									
Record anti-sweat heater voltage and amp draw.		X									
Record case product temperature.	X										
Record unit discharge air temperature.	X										
Record unit return air temperature.	X										
Record ambient conditions around unit (wet Bulb temperature and dry bulb temperature).	X										
Check product loading, do not load beyond the units load limits.	X										
Verify clearances on sides/back of unit.	X										
Check unit controller for proper operation. See controller or 1/0 Manual for proper controller operation.		X									
Confirm door switches function.	X										
Verify unit doors and lids work and are sealed correctly.	X										
Verify that all the panels, shields and covers are in place.	X										

Technician Notes:

SERVICE

REPLACING FAN MOTORS AND BLADES

Should it ever be necessary to service or replace the fan motors or blades be certain that the fan blades are replaced correctly.

THE BLADES MUST BE INSTALLED WITH RAISED EMBOSING (PART NUMBER ON PLASTIC BLADES) POSITIONED AS INDICATED ON THE PARTS LIST.

For access to these fans:

WARNING

Product will be degraded and may spoil if allowed to sit in a non-refrigerated area.

1. Remove product and place in a refrigerated area. Turn off power to the merchandiser.
2. Remove thumb screws that secure the return air grille / coil cover.
3. **Remove return air grille.**
4. Remove fan assembly.
5. Replace fan motor and blade.
6. Reconnect fan to wiring harness.
7. Replace return air grille, and fasten air grille to coil cover.
8. Turn on power.
9. Verify that motor is working and blade is turning in the correct direction.

WARNING

— LOCK OUT / TAG OUT —

To avoid serious injury or death from electrical shock, always disconnect the electrical power at the main disconnect when servicing or replacing any electrical component. This includes, but is not limited to, such items as doors, lights, fans, heaters, and thermostats.



HGM Fan

REPLACING THERMOMETER

The thermometer may be replaced by removing the two screws holding it to the evaporator fan grille. Lower the evaporator coil cover by removing the brass screws located at the two front corners of the cover. Remove the screws along the front edge of the cover holding it to the grille. Follow the sensing lead to the center rear of the evaporator coil. Loosen the clip holding it to the bracket, and slide the end of the lead out.

Be sure to run the lead of the new thermometer through the hole in the fan grille first. Finish assembly in reverse order. The same procedure should be followed when cleaning the end of the sensing lead.

TROUBLESHOOTING GUIDE		
PROBLEM	PROBABLE CAUSE	SOLUTION
Compressor runs continuously; product too warm	<ol style="list-style-type: none"> 1. Short of refrigerant 2. Inefficient compressor 3. Dirty condenser 	<ol style="list-style-type: none"> 1. Leak check, change drier, evacuate and recharge 2. Replace 3. Clean
High head pressure	<ol style="list-style-type: none"> 1. Cabinet location too warm 2. Restricted condenser air flow 3. Defective condenser fan motor 4. Air or non-condensable gases in system 	<ol style="list-style-type: none"> 1. Relocate cabinet 2. Clean condenser to remove air flow restriction 3. Replace 4. Leak check, change drier, evacuate and recharge
Warm storage temperature	<ol style="list-style-type: none"> 1. Temperature control not set properly 2. Short of refrigerant 3. Cabinet location too warm 4. Too much refrigerant 5. Low voltage, compressor cycling on overload 6. Condenser dirty 	<ol style="list-style-type: none"> 1. Reset control. 2. Leak check, replace drier evacuate and recharge 3. Relocate 4. Change drier evacuate and recharge 5. Check power 6. Clean
Compressor runs continuously; product too cold	<ol style="list-style-type: none"> 1. Defective control 2. Short on refrigerant 	<ol style="list-style-type: none"> 1. Replace 2. Assure proper length in tube 3. Leak check, change drier, evacuate and recharge
Compressor will not start; no noise	<ol style="list-style-type: none"> 1. Blown fuse or breaker 2. Defective or broken wiring 3. Defective overload 4. Defective temperature control 5. Power disconnected 	<ol style="list-style-type: none"> 1. Replace fuse or reset breaker 2. Repair or replace 3. Replace 4. Replace 5. Check service cords or wiring connections
Compressor will not start cuts out on overload	<ol style="list-style-type: none"> 1. Low voltage 2. Defective compressor 3. Defective relay 4. Restriction or moisture 5. Inadequate air over condenser 6. Defective condenser fan motor 	<ol style="list-style-type: none"> 1. Contact electrician 2. Replace 3. Replace 4. Leak check, replace drier, evacuate and recharge 5. Clean condenser 6. Replace

REPLACING DOOR PARTS

Hussmann provides replacement doors. See door parts listed on the next page, and contact your Hussmann representative to place an order for replacement doors. Door frame assemblies, LEDs, powersupplies, lamps, ballasts, door handles and hold open slides must be ordered direct from the door manufacturer. Refer to the supplemental manuals from Anthony. Refer to specific warranty supplied with the door. The manufacturers have a warranty against moisture penetration, a warranty against tempered glass breakage, and a warranty on ballasts. Lamps are not covered by Hussmann or the door manufacturer.

Anthony® door and frame service instructions are available at the end of this manual and online at the door manufacturer’s website: www.anthonyintl.com The names of the instruction manuals for the doors are listed below:

99-16105-S001_B 101B, 210X, ELM, 101X
Frame Installation and Service Manual

OR

99-16105-I001_E 101B, 210X, ELM, VSTB
Installation Manual
Anthony®
Phone: 1(800) 772-0900

**1-door power supply
or ballast location -
behind upper frame**

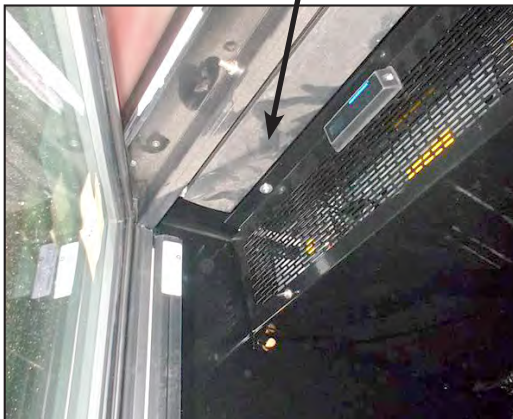

SERVICING LED LIGHTING

Refer to door manufacturer’s manual for information about servicing of LED lamps at the end of this manual. Additional manuals are available on the Anthony® website: www.anthonyintl.com to download LED and powersupply replacement instructions. The names of the instruction manuals for the lights are listed below:

99-19830-I001_C OptiMax Pro 24 Installation Instructions
99-18901-I001_B OptiMax Pro Retrofit Instructions

SERVICING FLUORESCENT LIGHTING

Refer to door manufacturer’s manual at the end of this manual for information about servicing fluorescent lamps. Please visit: www.anthonyintl.com to download LED and powersupply replacement instructions. The names of the instruction manuals for the lights are listed below:

99-20367-I001_C ELS Ballast Replacement
99-20374-I001_C ELS T-8 Lamp Replacement

**2 and 3-door power supply
or ballast location - inside
center mullions**



Replacement Parts List

Standard Parts	Part Number	HGM1BS	HGM2BS	HGM3BS	HGM1TS	HGM2TS	HGM3TS
Evaporator Fan Motor	0477654	X	X	X	X	X	X
Evaporator Fan Blade	0501426	X			X		
Evaporator Fan Harness Plug	19S785	X			X		
Evaporator Fan Blade	0519568		X	X		X	X
Evaporator Fan Harness	0517365		X			X	
Evaporator Fan Harness	0518201			X			X
Air Sensor (Black) 4000MM	0510533	X	X	X	X	X	X
Safe-Net III Controller 65C	0524126	X	X	X	X	X	X
Safe-Net III Display (F°) 65C	0527186	X	X	X	X	X	X
Safe-Net III Display Interface Cable	0509783	X	X	X	X	X	X
Safe-Net III Control Harness	0513058	X	X	X	X	X	X
Compressor Relay	0459304	X	X	X	X	X	X
Power Switch	03S286	X	X	X	X	X	X
Solar Thermometer	05S528	X	X	X	X	X	X
Cantilever Shelf (White)	22S268	X	X	X	X	X	X
Bottom Shelf (White) 1 per door	22S128	X	X	X	X	X	X
Wire Rear Flue Spacer (1 per door)	22S121	X	X	X	X	X	X
Legs Adjustable 6" (TS Only)	35S032				X	X	X
Power Cord (5-15P) NEMA 5-15P	19S216	X	X		X	X	
Power Cord (5-20P) NEMA 5-20P	19S63612			X			X

Refrigeration	Part Number	HGM1BS	HGM2BS	HGM3BS	HGM1TS	HGM2TS	HGM3TS
Compressor (FFU100HAK)	0518077	X			X		
Compressor (NEK6187Z)	2000575		X	X		X	X
Condenser	2100516	X			X		
Condenser	E108804		X			X	
Condenser	25S050			X			X
Condenser Fan Motor	1804579	X	X	X	X	X	X
Condenser Fan Blade	1700156	X			X		
Condenser Fan Blade	0510453		X			X	
Condenser Fan Blade	21S017			X			X
Condenser Fan Motor Bracket	0201543	X			X		
Condenser Fan Motor Bracket	0438051		X			X	
Condenser Fan Motor Bracket	21S007			X			X
Evaporator Coil	25S121	X			X		
Evaporator Coil	26S0741		X			X	
Evaporator Coil	26S0742			X			X
Pullout Coil Asm.	953070	X					
Pullout Coil Asm.	952350		X				
Pullout Coil Asm.	95201			X			
Filter Drier (Sporlan C-032-S-T)	17S332	X	X		X	X	
Filter Drier (Sporlan C-052-S)	17S362			X			X
Accumulator	17S489	X			X		
Accumulator	17S098		X	X		X	X

Replacement Parts List

Condensate Pan

HGM1BS HGM2BS HGM3BS HGM1TS HGM2TS HGM3TS

Water Dissipation Tray (Sits on Compressor)	0513851	X	X	X			
Condensate Pan Complete w/Fan & Plug	951442				X	X	X
Condensate Pan Fan Motor	0404551				X	X	X
Condensate Fan Motor Plug	0526612				X	X	X

Sheet Metal Replacement Parts Painted

HGM1BS HGM2BS HGM3BS HGM1TS HGM2TS HGM3TS

Front Louvered Access Panel w/SNIII KO	950851	X					
Front Louvered Access Panel w/SNIII KO	950852		X				
Front Louvered Access Panel w/SNIII KO	950853			X			
Front Access Panel w/ SNIII KO	953451				X		
Front Access Panel w/ SNIII KO	953452					X	
Front Access Panel w/ SNIII KO	953453						X
Evaporator Drain Pan Cover	950771	X			X		
Evaporator Drain Pan Cover	950772		X			X	
Evaporator Drain Pan Cover	950773			X			X
Front Evaporator Grille	954101	X			X		
Front Evaporator Grille	954102		X			X	
Front Evaporator Grille	954103			X			X

All these part numbers above are painted assemblies

Door Replacement Parts Painted

HGM1BS HGM2BS HGM3BS HGM1TS HGM2TS HGM3TS

Door Med Temp Silver (LED)	0544038	X	X	X	X	X	X
Door Med Temp Black (LED)	0544043	X	X	X	X	X	X



Serial Plate Location

Hussmann Part Number

Anthony Work Order Number

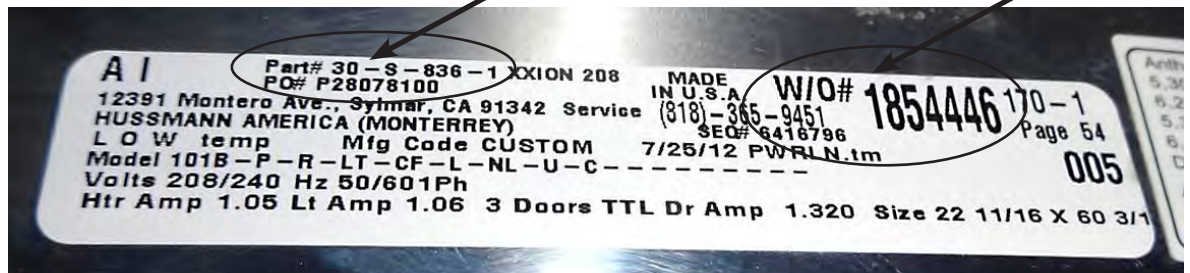

HGM-1BS — Plan View

Dimensions shown as inches and (mm).

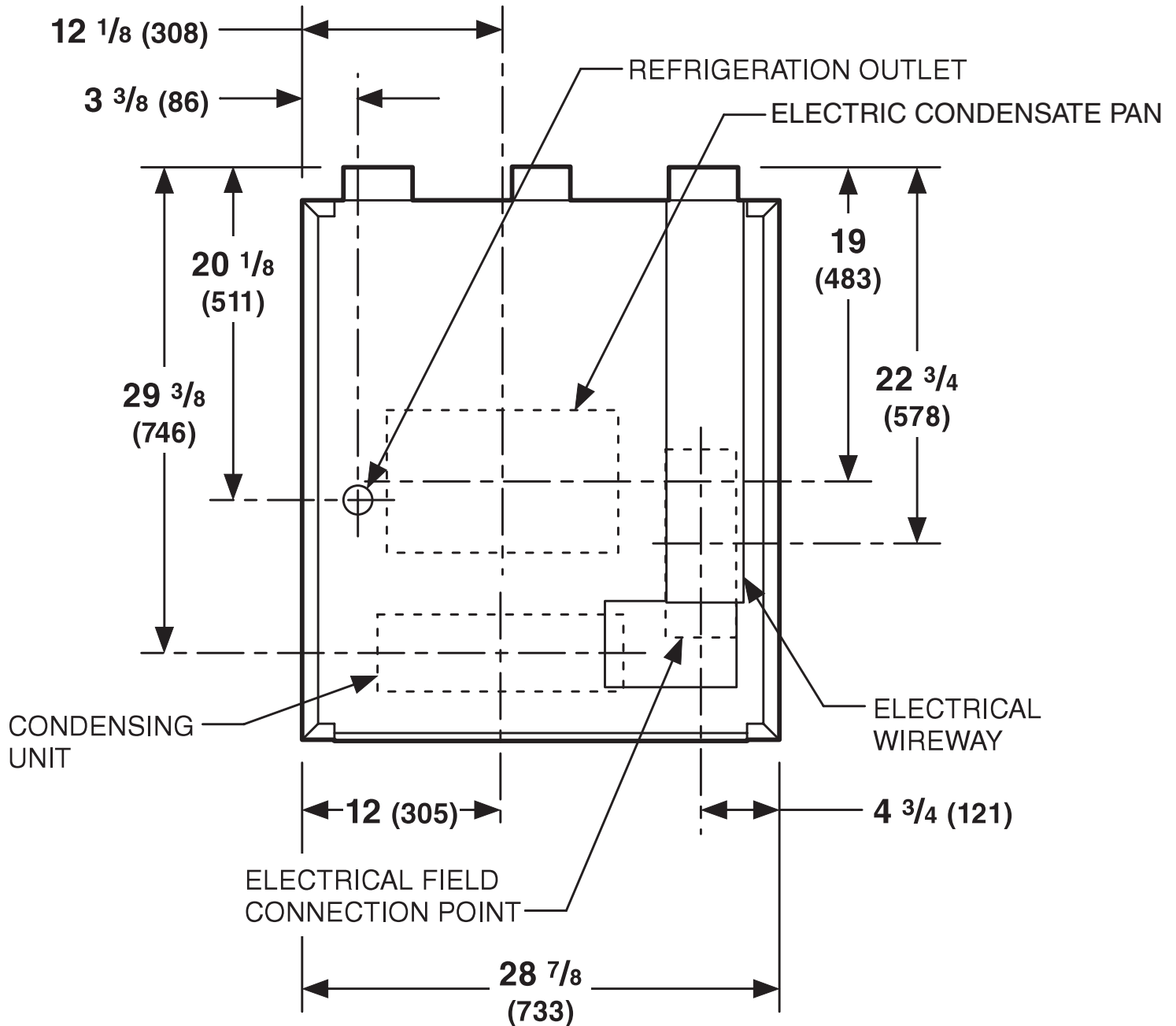

HGM-2BS & HGM-3BS — Plan View

Dimensions shown as inches and (mm).

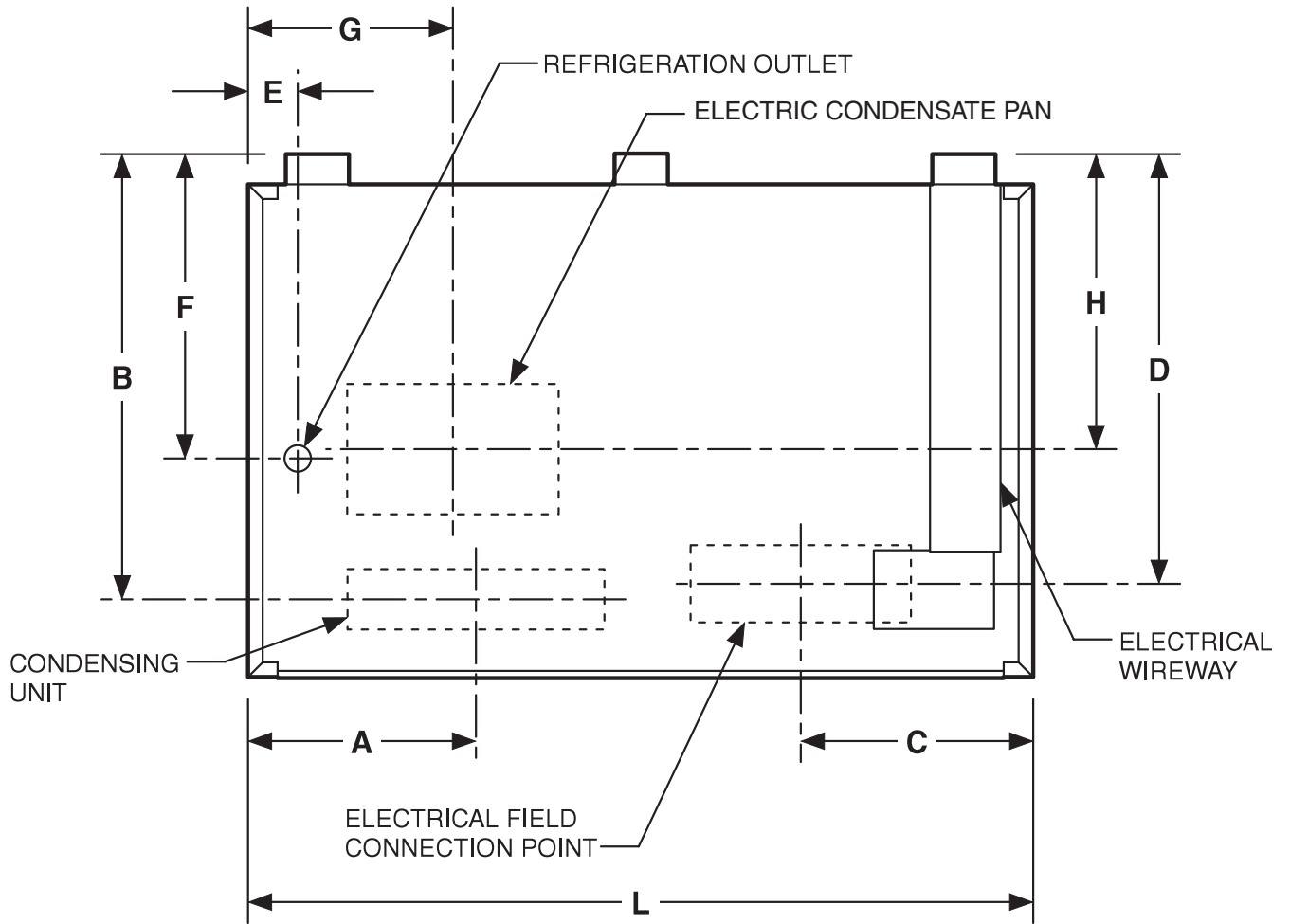

Model	HGL-2BS	HGL-3BS
A	13 1/2 (343)	16 1/8 (410)
B	29 1/2 (749)	27 (686)
C	15 3/8 (391)	15 3/8 (391)
D	27 3/8 (695)	27 1/2 (699)
E	3 1/4 (83)	3 3/8 (86)
F	20 1/8 (511)	20 1/8 (511)
G	13 5/8 (346)	16 1/2 (419)
H	19 1/8 (486)	15 1/8 (384)
Length (L)	52 (1321)	75 3/8 (1915)

HGM-1TS — Plan View

Dimensions shown as inches and (mm).

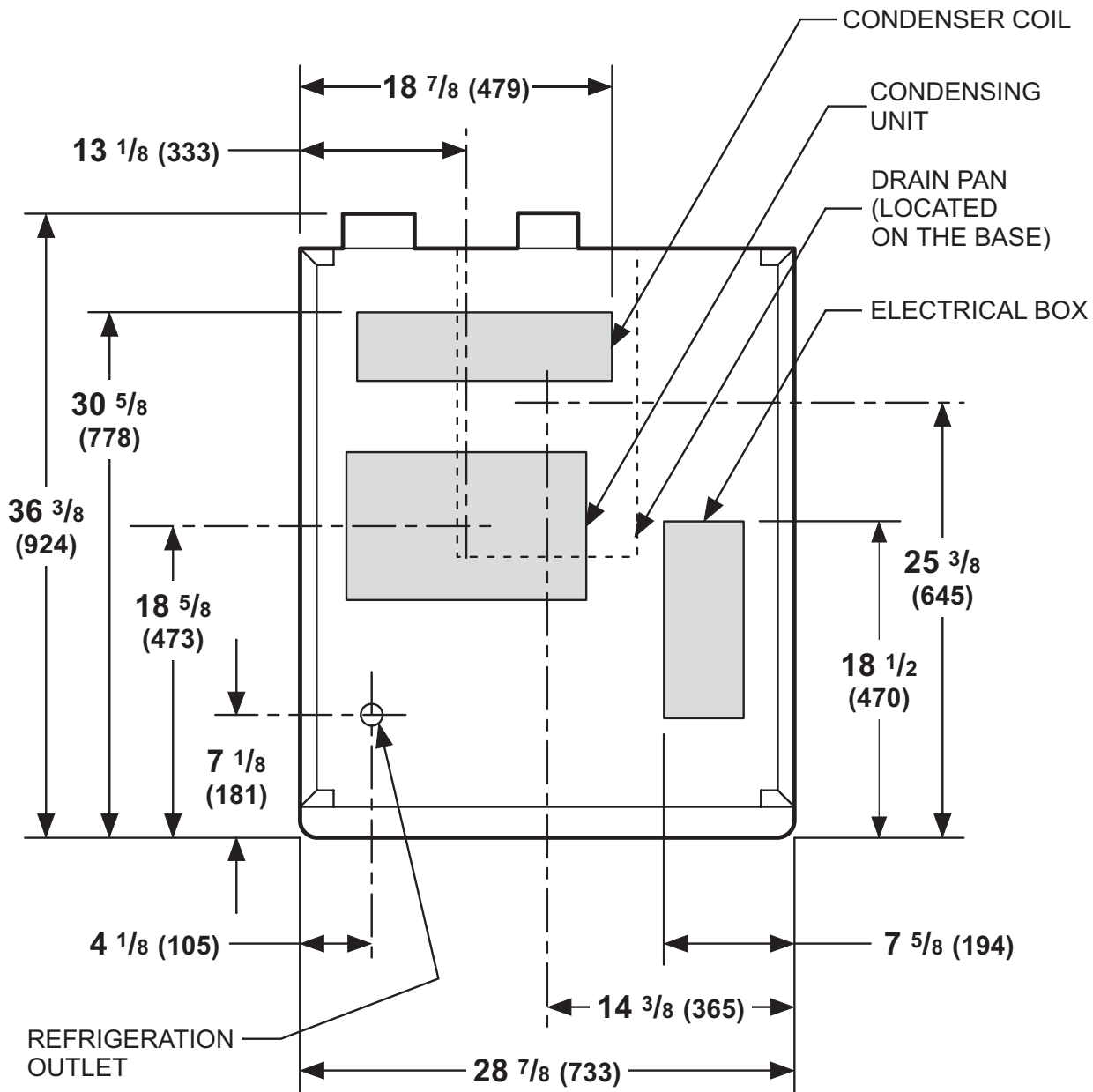

HGM-2TS — Plan View

Dimensions shown as inches and (mm).

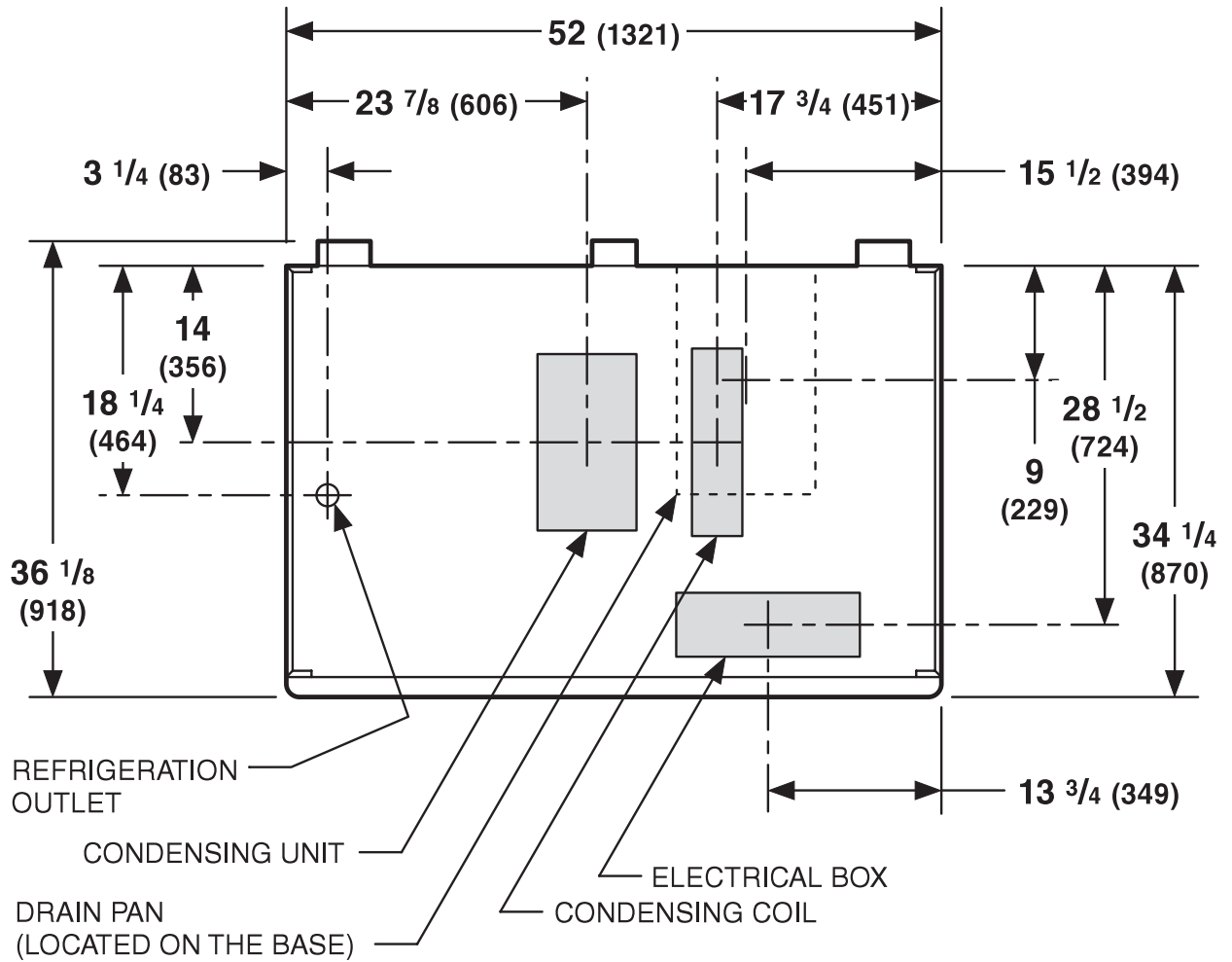

HGM-3TS — Plan View

Dimensions shown as inches and (mm).

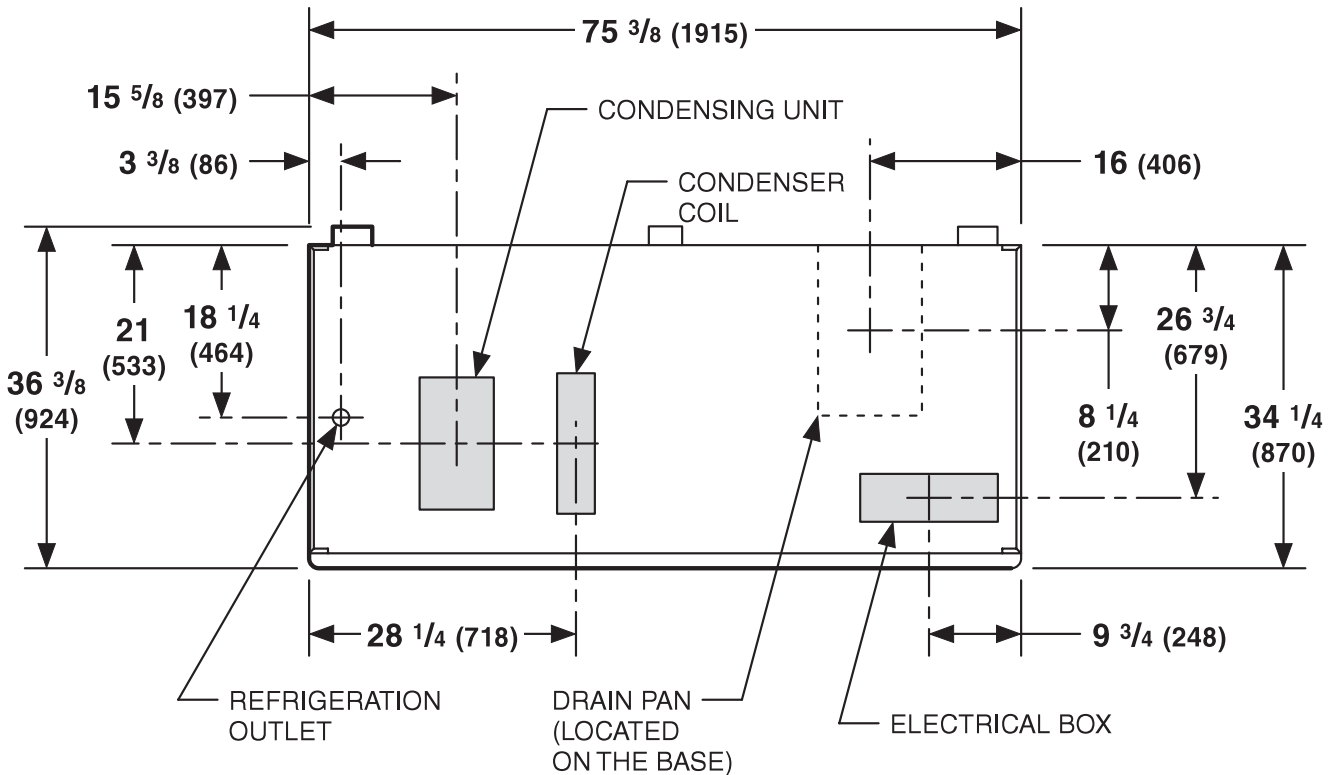

HGM — Dimensions

Model	Exterior Dimensions (inches)			Interior Volume [liters] (cubic feet)	Nominal HP	Refrigerant Type	Volts	Run Amps
	L	D	H					
HGM-1BS	28 7/8	34 5/8	80 9/16	685 (24.19)	1/3	R-134A	115	11.9
HGM-1B	28 7/8	34 5/8	80 9/16	685 (24.19)	—	R-134A	115	5.3
HGM-2BS	52	34 5/8	80 9/16	1327 (46.86)	1/2	R-134A	115	12.5
HGM-2B	52	34 5/8	80 9/16	1327 (46.86)	—	R-134A	115	6.0
HGM-3BS	75 3/8	34 5/8	80 9/16	1999 (70.60)	3/4	R-134A	115	20.5
HGM-3B	75 3/8	34 5/8	80 9/16	1999 (70.60)	—	R-134A	115	8.0

*Field hard wired

Model	Exterior Dimensions (inches)			Interior Volume [liters] (cubic feet)	Nominal HP	Refrigerant Type	Volts	Run Amps
	L	D	H					
HGM-1TS	28 7/8	36 1/8	84 1/4	685 (24.19)	1/3	R-134A	115	11.8
HGM-1T	28 7/8	36 1/8	84 1/4	685 (24.19)	—	R-134A	115	5.3
HGM-2TS	52	36 1/8	84 1/4	1327 (46.86)	1/2	R-134A	115	12.5
HGM-2T	52	36 1/8	84 1/4	1327 (46.86)	—	R-134A	115	6.0
HGM-3TS	75 3/8	36 1/8	84 1/4	1999 (70.60)	3/4	R-134A	115	20.5
HGM-3T	75 3/8	36 1/8	84 1/4	1999 (70.60)	—	R-134A	115	8.0

*Field hard wired

HGM — Electrical Data

Model	*Refrigeration Load (BTU/h)	A/C Load (BTU/h)	Energy Consumption (kWh/day)
HGM-1BS	1870	2575	5.46
HGM-1B		—	—
HGM-2BS	2300	3165	8.96
HGM-2B		—	—
HGM-3BS	4270	5875	9.84
HGM-3B		—	—

*Refrigeration load calculated at 10° F evaporation temperature and 110° F condensing temperature

Model	*Refrigeration Load (BTU/h)	A/C Load (BTU/h)	Energy Consumption (kWh/day)
HGM-1TS	1870	2575	5.46
HGM-1T		—	—
HGM-2TS	2300	3165	8.96
HGM-2T		—	—
HGM-3TS	4270	5875	9.84
HGM-3T		—	—

*Refrigeration load calculated at 10° F evaporation temperature and 110° F condensing temperature

A-7 APPENDIX A — TECHNICAL DATA

Dimensions shown as inches and (mm).

HGM-BS — Cross Section

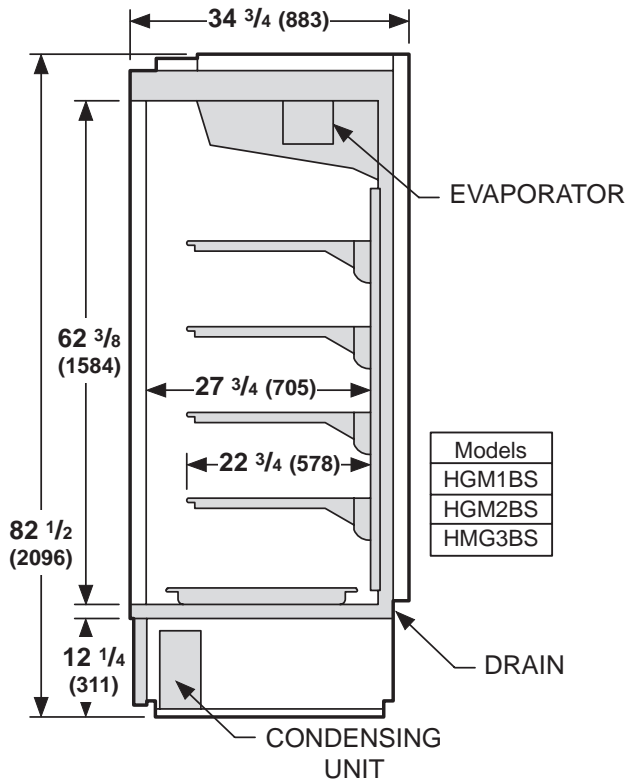

REFRIGERATION DATA

	HGM
Thermostat	
Setting CI/CO (°F)	
Position #1	39 / 32
Position #7	36 / 23
Compressor (hp)	
HGM-1	$\frac{1}{3}$
HGM-2	$\frac{1}{2}$
HGM-3	$\frac{3}{4}$
Condensing Unit	
Capacity	
(Btu/hr at std. rating conditions)	
HGM-1	1870
HGM-2	2300
HGM-3	4270
(at 10° F evaporator and 110° F condensing temperature)	

HGM-TS — Cross Section

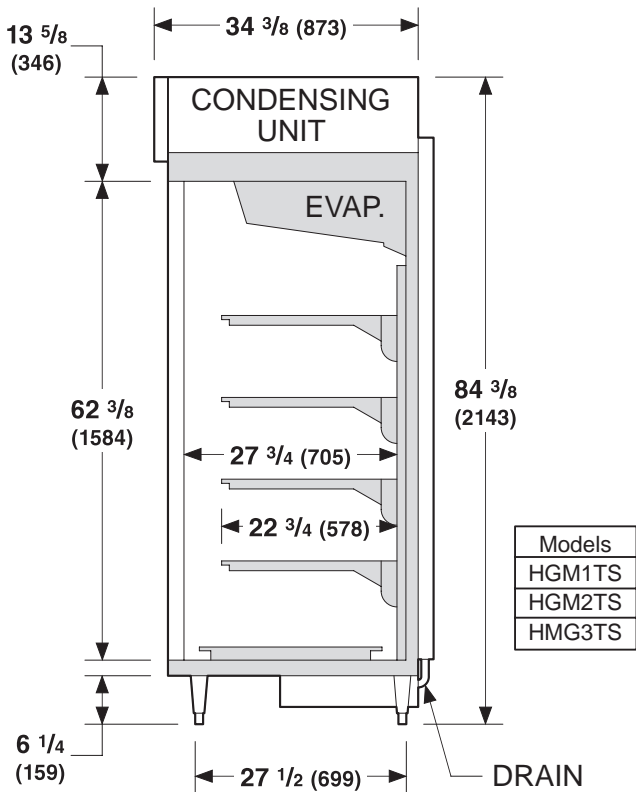

DEFROST DATA

	HGM
Frequency (hr)	12
Defrost Termination Temperature	48° F
OFFTIME	
Failsafe (min.)	30

PHYSICAL DATA

Refrigerant Charge R134A		
HGM-1	14.1 oz	(0.4) kg
HGM-2	40.25 oz	(1.14) kg
HGM-3	37.75 oz	(1.07) kg

Note: This data is based on store temperature and humidity that does not exceed 75°F and 55% R.H. unless otherwise stated. Schedule defrost at night while lights are off.

HGM-1 BS / TS

ANTHONY DOORS & FRAMES

FRAME HEATERS

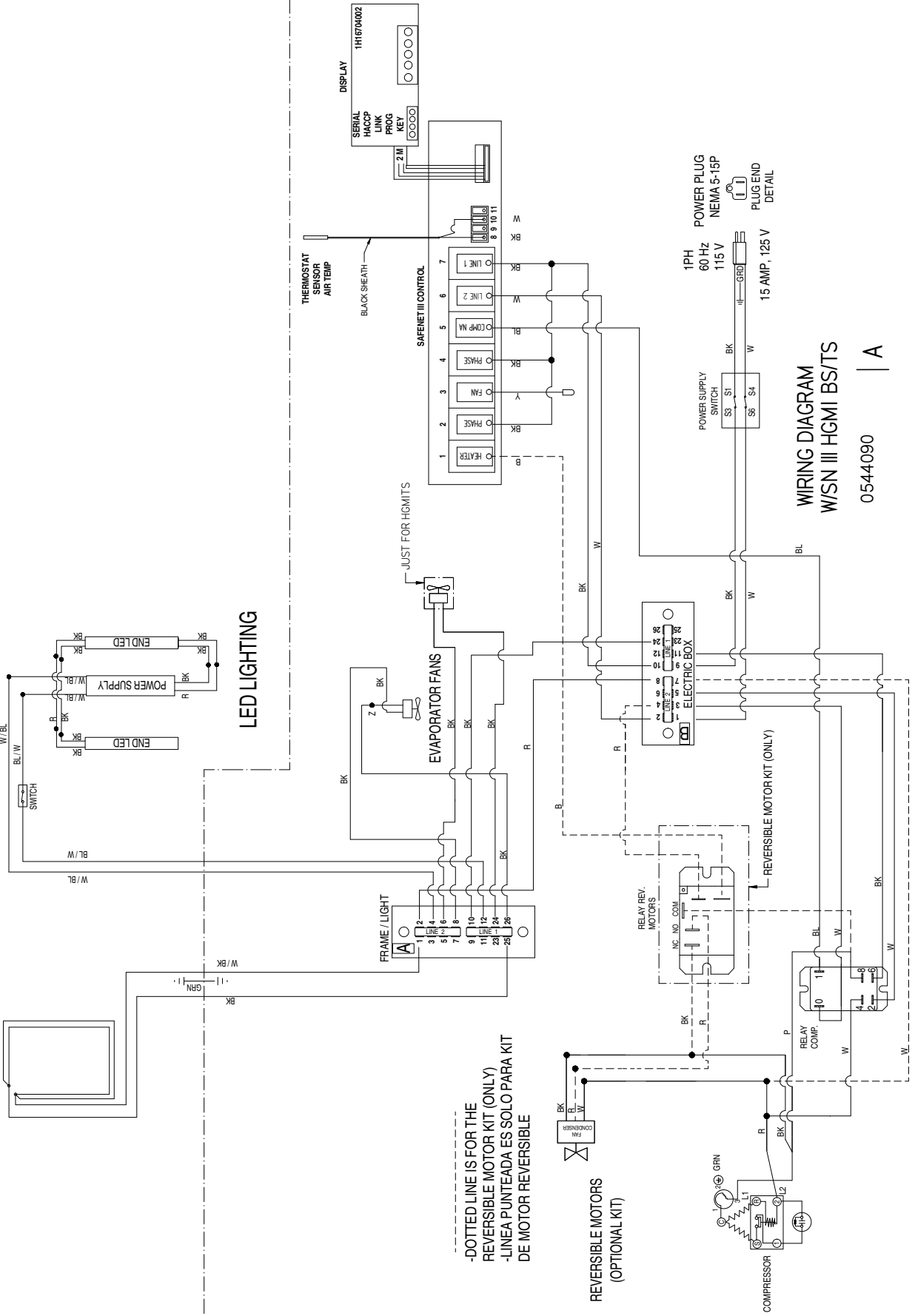

WIRING DIAGRAM
W/SN III HGM1 BS/TS
0544090 | A

-DOTTED LINE IS FOR THE
REVERSIBLE MOTOR KIT (ONLY)
-LINEA PUNTEADA ES SOLO PARA KIT
DE MOTOR REVERSIBLE

HGM-2 BS / TS

ANTHONY DOORS & FRAMES

FRAME HEATERS

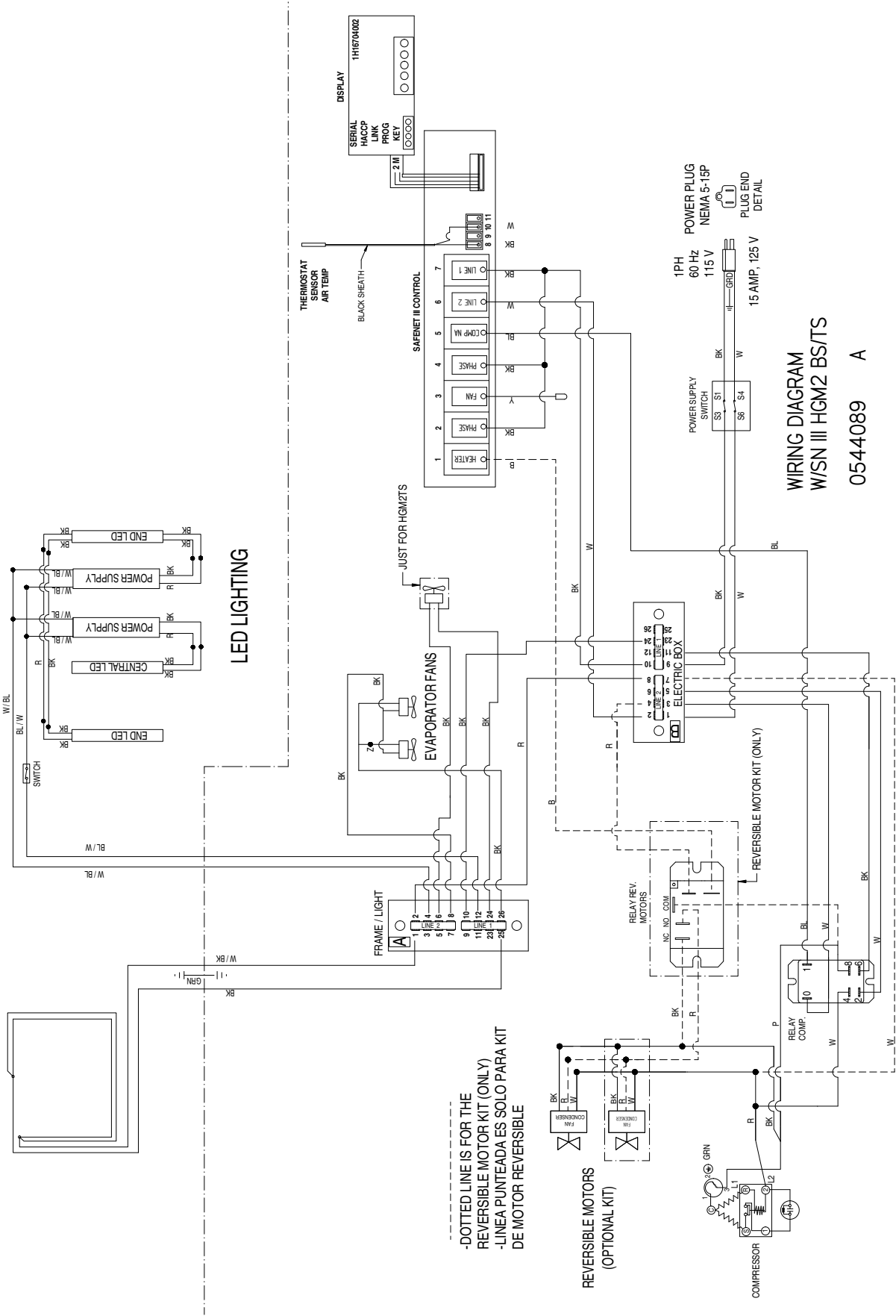

WIRING DIAGRAM
W/SN III HGM2 BS/TS
0544089 A

HGM-3 BS / TS

ANTHONY DOORS & FRAMES

FRAME HEATERS

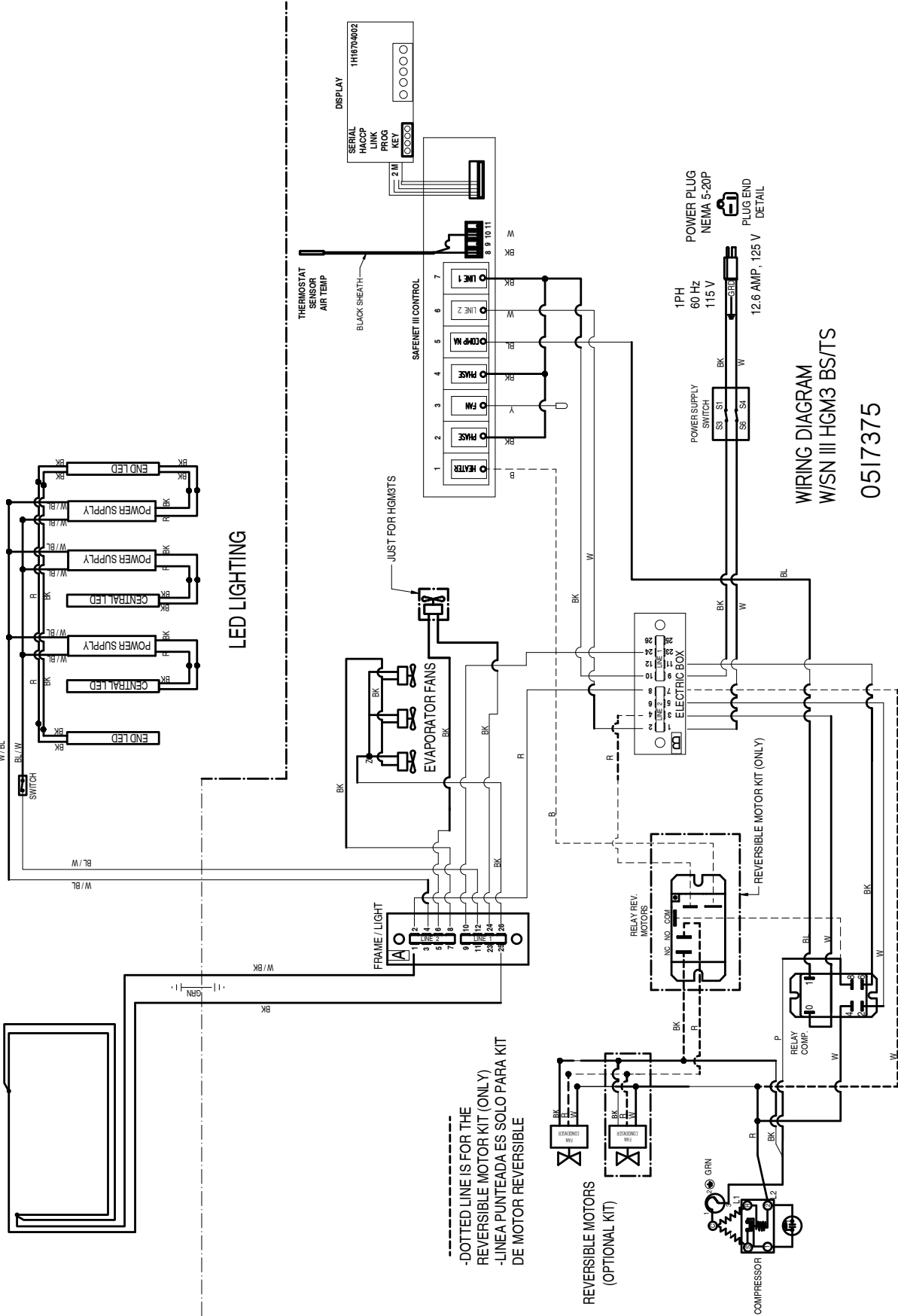

WIRING DIAGRAM
W/SN III HGM3 BS/TS
0517375

HGM-2 B / T

ANTHONY DOORS & FRAMES

FRAME HEATERS

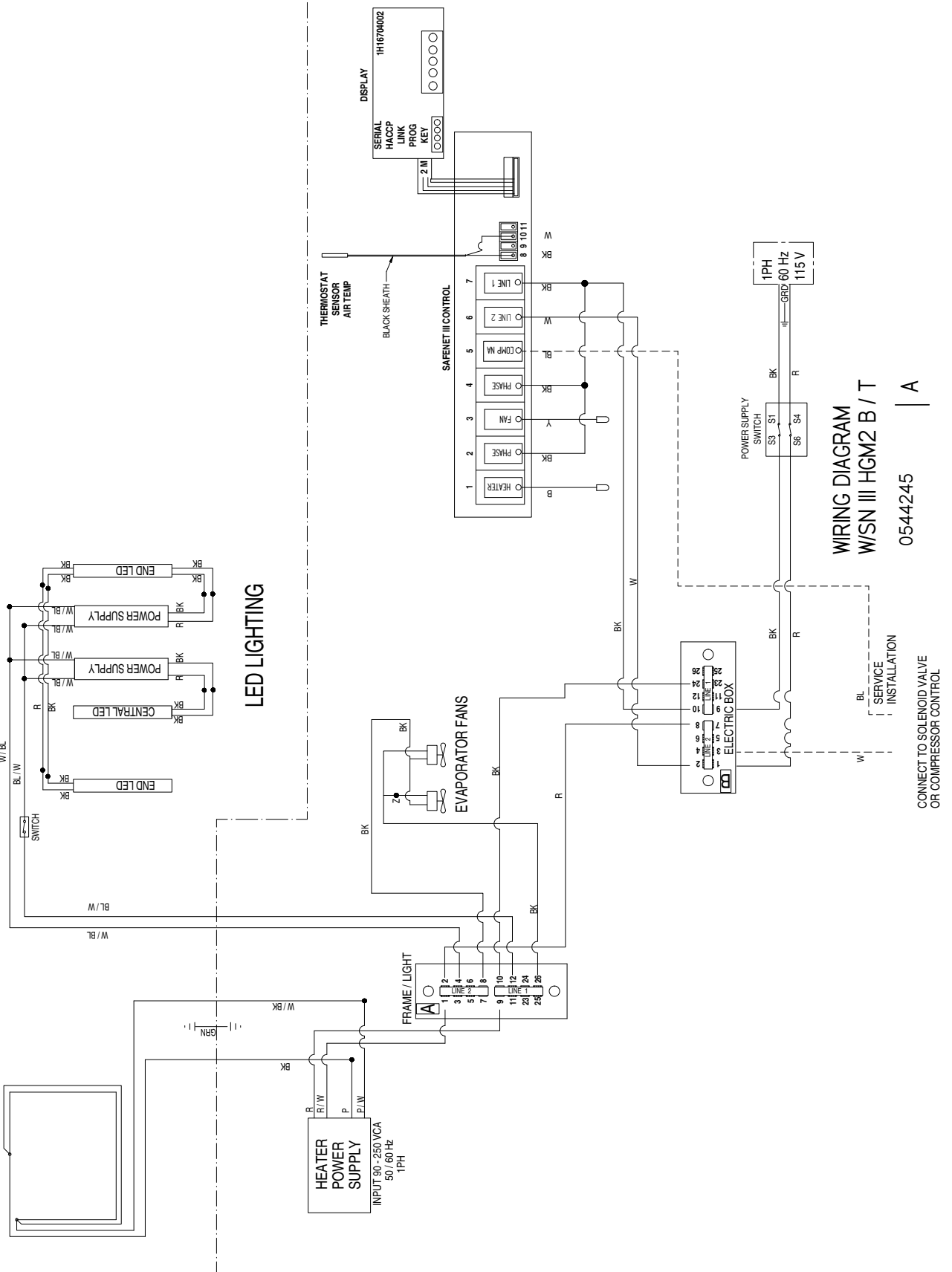

WIRING DIAGRAM
W/SN III HGM2 B / T

0544245

A

CONNECT TO SOLENOID VALVE
OR COMPRESSOR CONTROL

HGM-3 B / T

ANTHONY DOORS & FRAMES

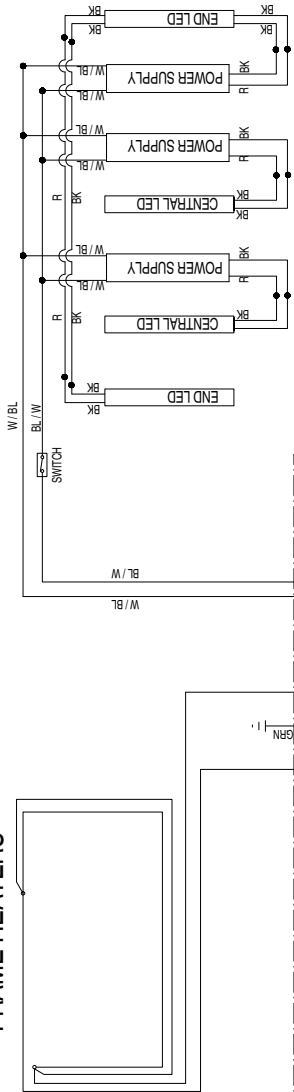

LED LIGHTING

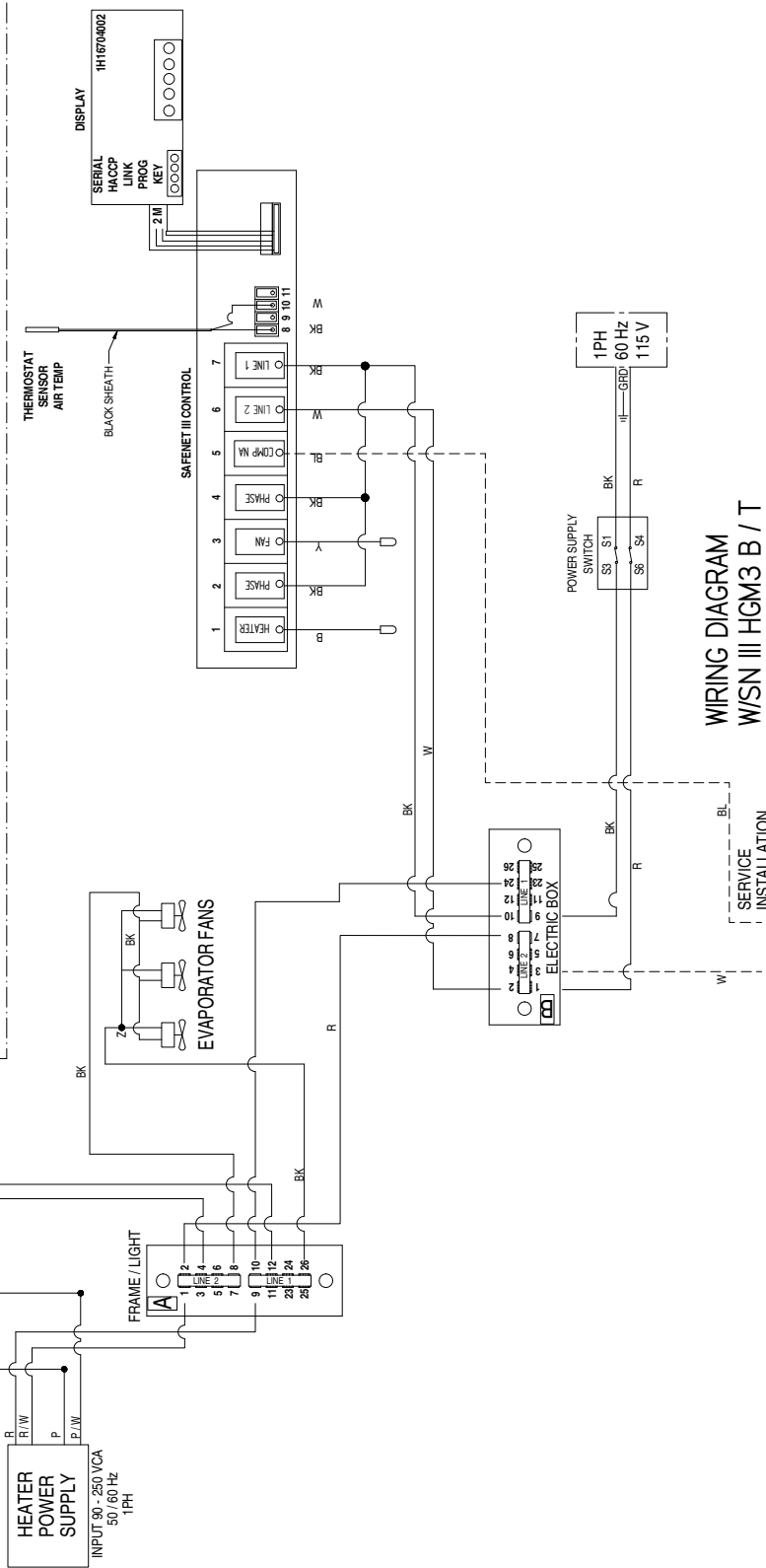

WIRING DIAGRAM W/SN III HGM3 B / T

0523287 B

CONNECT TO SOLENOID VALVE OR COMPRESSOR CONTROL

Anthony Door

Supplement

for Hussmann® Models



HGM

HGL

The following pages are reprinted by
permission of Anthony.
Copyright 2010 by Anthony

Copyright © 2010 by  Anthony

ALL rights reserved. Information in this document is subject to change without notice. Companies, names and data used in examples herein are fictitious unless otherwise noted. No part of this document may be reproduced or transmitted in any form or by any means, electronic or mechanical, for any purpose, without express permission of Anthony Manufacturing Co., Inc.

Anthony products identified in this manual are designed and certified to meet  or  for safety, and  for sanitation standards. European products meet  requirements. Each customer is responsible for final site approval.

PARTS REPLACEMENT

Diagram A: Model 101B & ELM Door Parts Placement

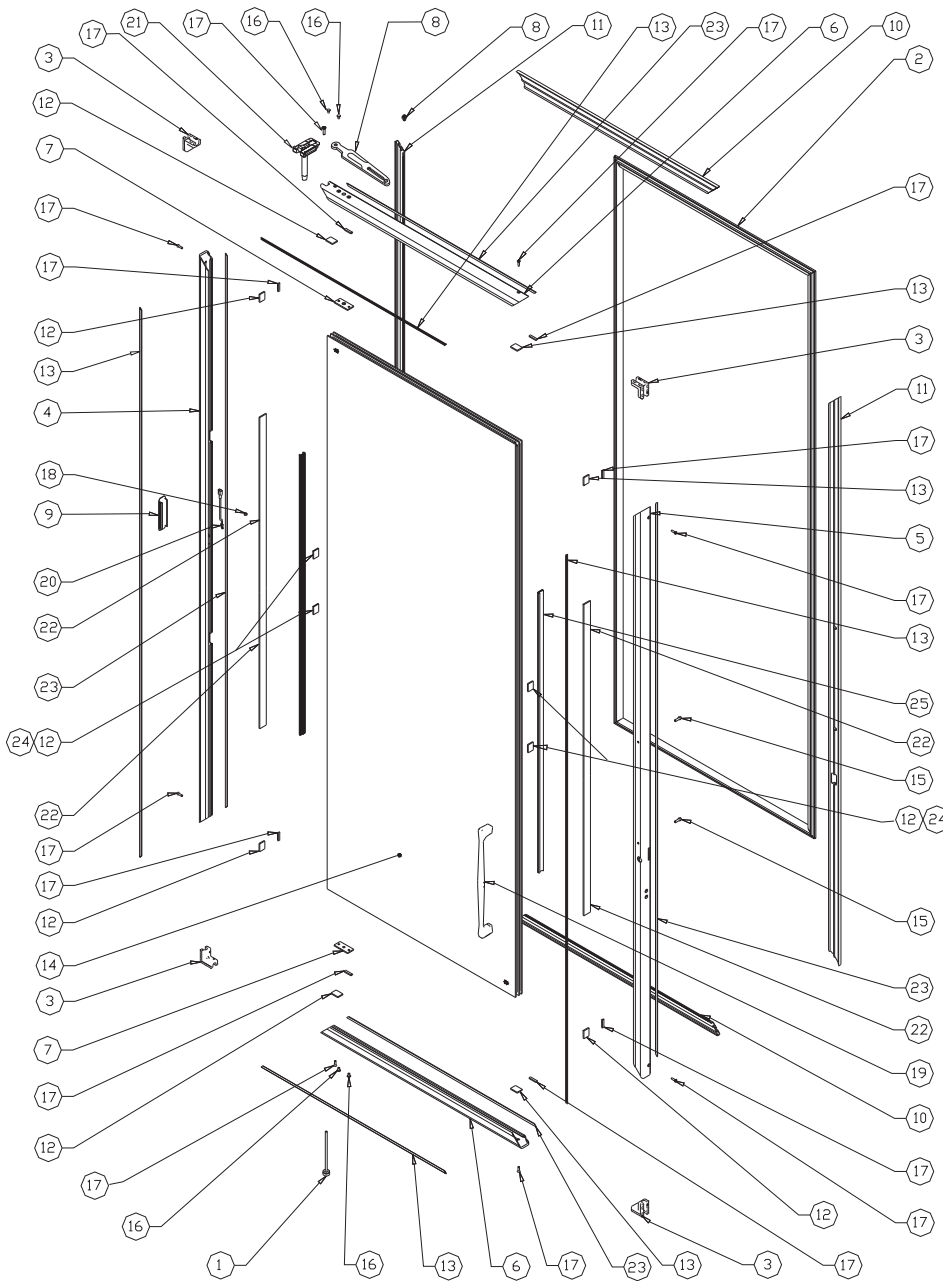

No.	Description
1.	Torque Rod Assembly
2.	Gasket with Magnet
3.	Corner Pieces
4.	Door Rail (Hinge side)
5.	Door Rail (Handle side)
6.	Top & Bottom Rail
7.	Hold Open Backing Plate
8.	Hold Open Fork & Spacer
9.	Access Hole Cover
10.	Top & Bottom Rail Cover
11.	Side Rail Covers
12.	Wedge Spacer
13.	Vinyl Glazing
14.	Glass Pack Assembly
15.	10-28 x 5/8" Screws
16.	3/16" x 3/8" x 3/8" Rivets
17.	8-32 x 5/8" Screws
18.	#42 Steel Rivets
19.	Slimline Handle
20.	Ground Wire Assembly
21.	Hinge Pin
22.	Sealant
23.	Foam Mounting Tape
24.	3M Hot Melt Sealant
25.	Door Handle Rail Insert

Diagram E: Model 101X ELS Fluorescent Lamp Assemblies

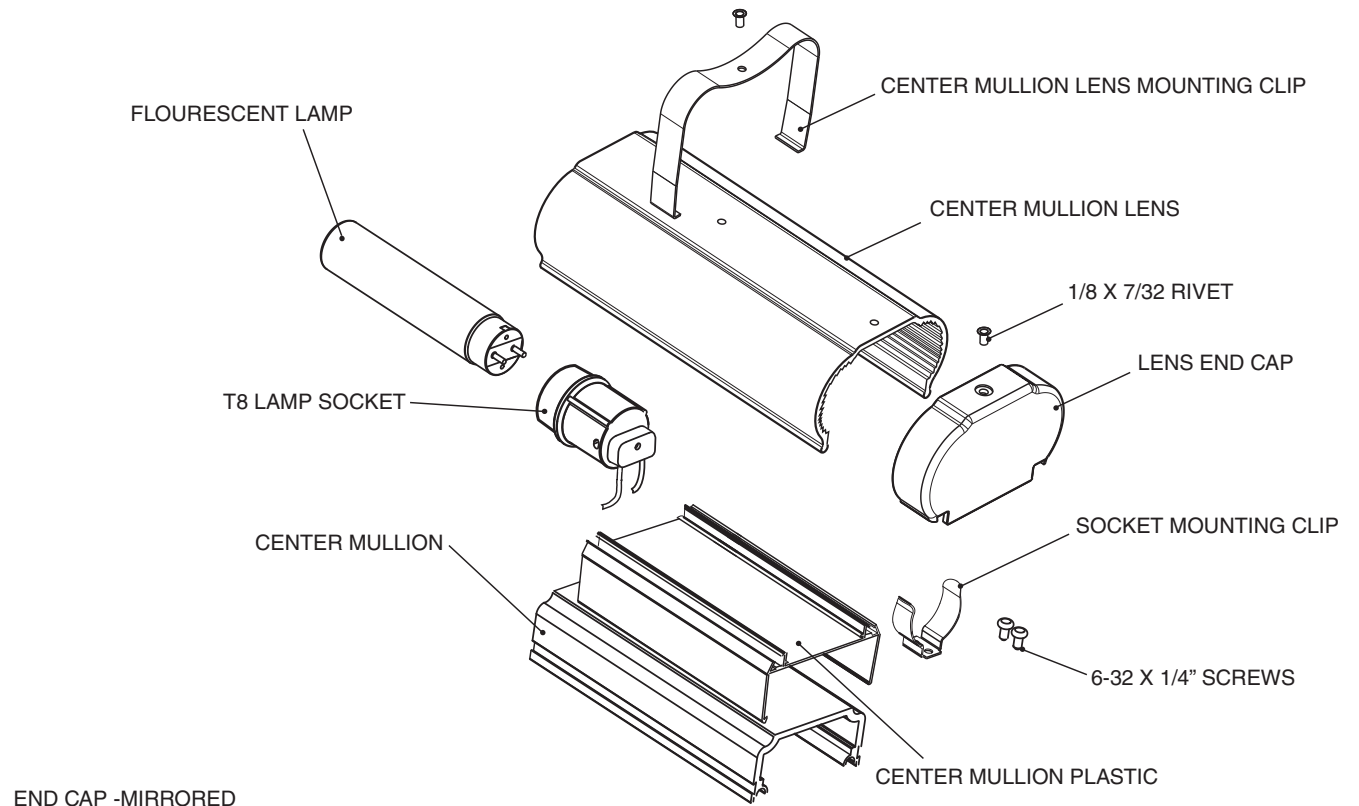

CENTER MULLION LAMP ASSEMBLY

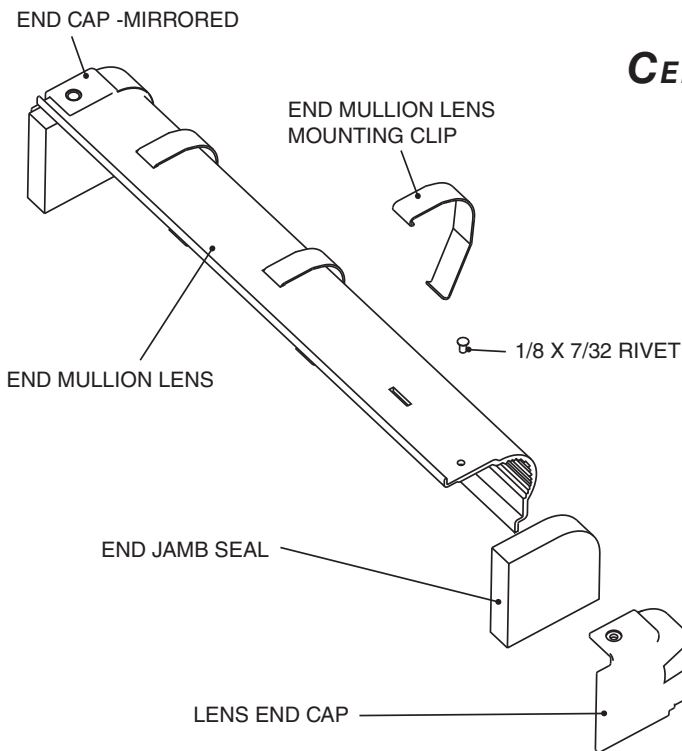

END MULLION LENS ASSEMBLY

Diagram F: Door & Frame Assembly Diagram

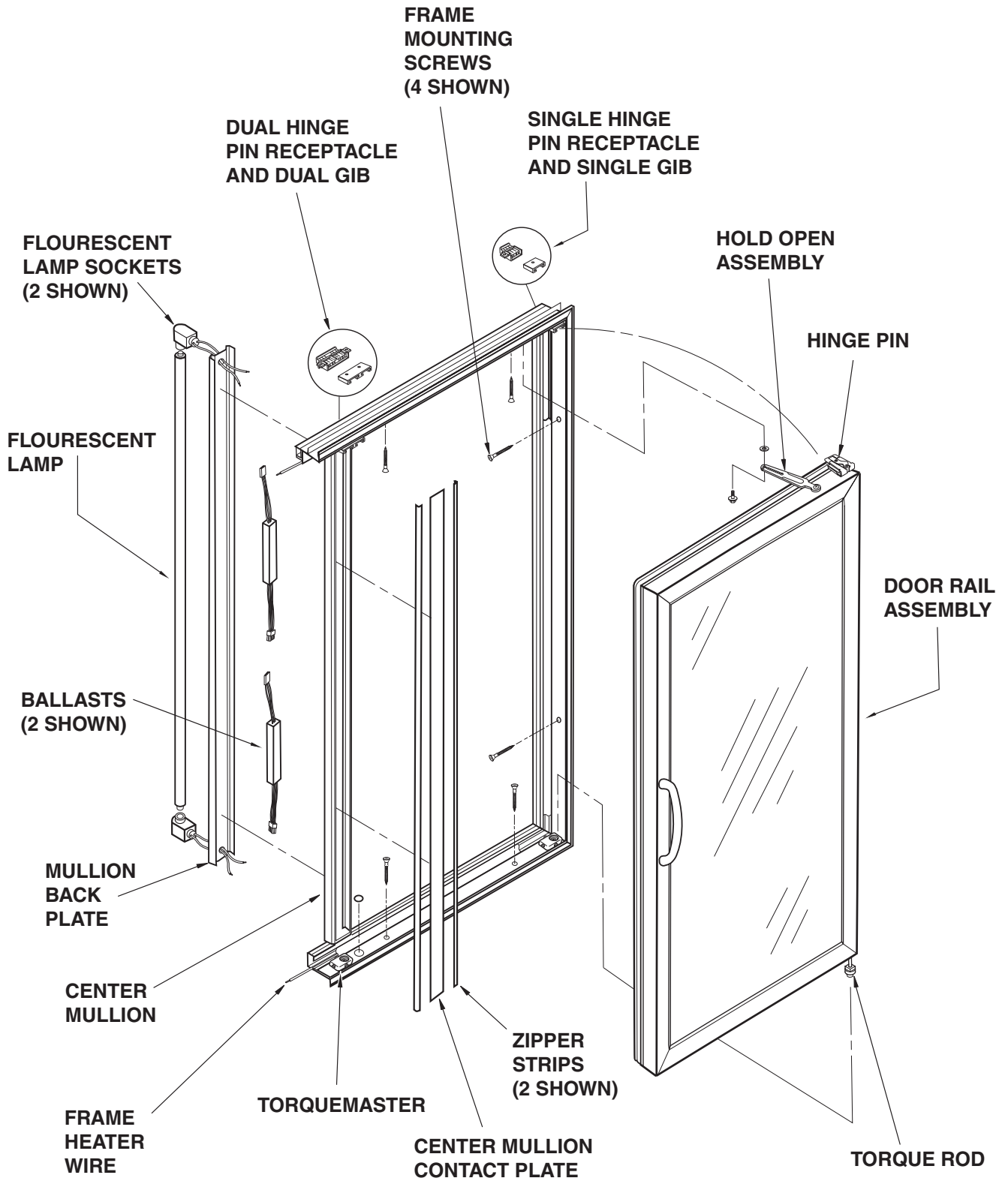

DOOR REMOVAL & REVERSAL

Removing the Door Assembly From the 101X Frame

1. Using a flat-head screwdriver, loosen the tension on the door by turning the adjustment screw, located on the front of the torquemaster, to the right or clockwise. Refer to figure (A)
2. Test the door by opening it, and confirm that the torque tension does not retract the door from open position.
3. If tension remains, continue adjusting the torquemaster until all tension has been removed from the door.
4. Open the door to access the hold open device then loosen and remove hold-open bolt, using a phillips-head screwdriver. Refer to figure (B)



A



B

5. Remove the hold open stud using a 7/16" hand wrench.
6. Retract the door to a near-closed position.
7. Insert the top half of the needle-nose pliers into the grip-hole, located in the hinge pin spring-clip, and the bottom half of the pliers beneath the hinge pin shroud. Refer to figure (C)
8. Squeeze the pliers to clamp down on the hinge pin spring clip, allowing the clip to release the hinge pin from the receptacle gib of the frame, while simultaneously pulling the top of the door away from the frame. This will release and pull the hinge pin out of the hinge pin receptacle and gib. Refer to figure (D)



C



D

9. Continue pulling the top of the door assembly away from the frame until the top door rail clears the frame.
10. Lift and remove the door from the torquemaster and carefully set the door aside. Refer to figure (E)



E

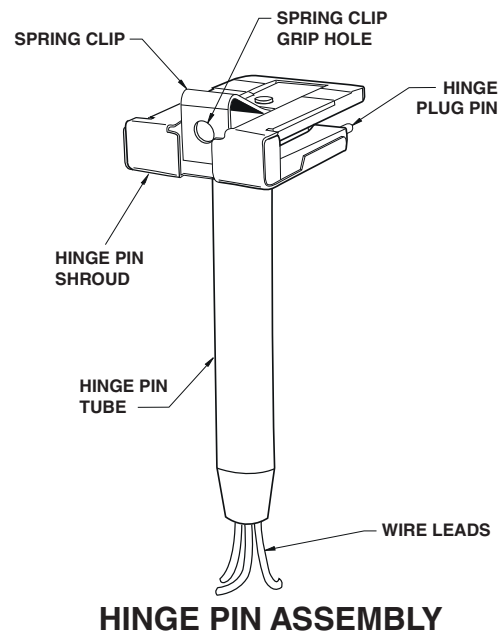

Reversing the Door Swing

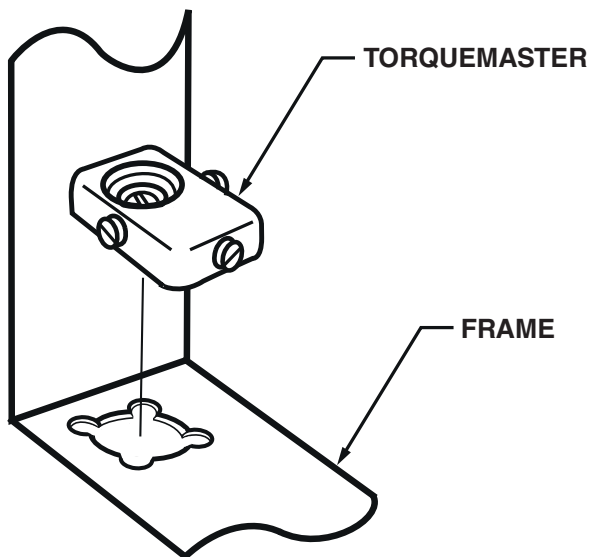

1. Using a flat-head screwdriver, loosen the torquemaster from its mount by turning the center mounting screw counter-clockwise less than one-half (1/2) of a turn. Refer to figure (A) Remove the Torquemaster, exposing the mounting hole in the bottom frame rail. Refer to figure (B)



A

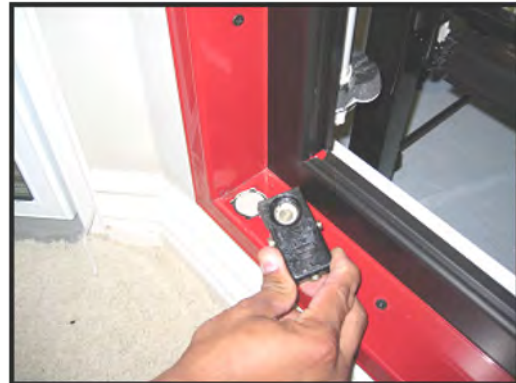

B

2. Locate the mounting hole at the opposite side of the door opening.
3. Using the flat-head screwdriver, carefully pry underneath the plug cap and remove it. Refer to figure (C)



C

4. Place the Torquemaster on the newly opened mounting hole, aligning the flanged corners of the mounting tabs. Refer to figure (D)

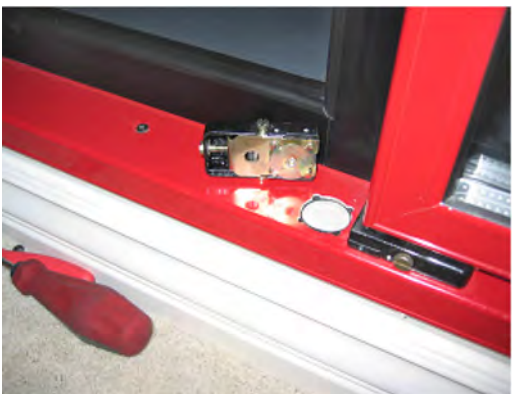

D

5. Insert the Torquemaster mounting tabs onto the mounting hole with the hollow end of the Torquemaster against the door frame.

6. Confirm that the mounting flanges on the bottom of the torquemaster align with the corner mounting slots of the mounting hole in the frame.
7. Using a flat-head screwdriver, turn the Torquemaster mounting set-screw clockwise, for 1/2 a turn, to tighten the mount and lock it in place. Confirm that the torquemaster mounting is flush with the door frame.
8. Using a 7/16" open-ended hand wrench, loosen and remove the hold-open detent bolt from the top frame rail. Refer to figure (E)
9. Relocate and install the hold-open shoulder bolts into the opposite hold-open mount of the same door frame. Refer to figure (F)



E



F

10. If installing in Reverse Geometry, insert the hold-open stand-off into the frame header and install the detent bolt into the top of the door then tighten each with a 7/16" open-ended hand wrench (see page 22 for complete Reverse Geometry installation instructions). Refer to figure (G)
11. Open the access portal to the hinge pin wire connections in the rail on the hinge side of the door assembly.
12. Disconnect the Hot, Neutral and Ground wires of the hinge pin from the heater wire circuit and the ground terminal. Refer to figure (H)



G



H

13. Loosen and completely remove the hinge pin assembly from the top door rail.

NOTE: Refer to "Removing and Replacing the Hinge Pin on page 31 for complete replacement procedures

- Using a plastic mallet and a flat-head screwdriver, remove the torque rod from the bottom of the door assembly.
Refer to figure (I)



I

- Swap placement of the Hinge Pin and Torque Rod to the other's original mounting hole in the door assembly hinge side rail.
- Reinstall the hinge pin and the torque rod completely into the ends of the door assembly hinge rail.
- If necessary, lightly tap on the hinge pin and torque rod with a plastic or rubber mallet until each is fully seated into the top and bottom of the door.
- Reconnect the hinge in wires and confirm that all connections are secure.
- Check and confirm torque rod and hinge pin are correctly and completely installed.
- Reinstall the door into the frame.

NOTE: Refer to www.anthonydoors.com for complete door/frame installation instructions.

ORIENTATION OF CENTER FIXTURES

Center Mullion LED Fixture Mounting Instructions

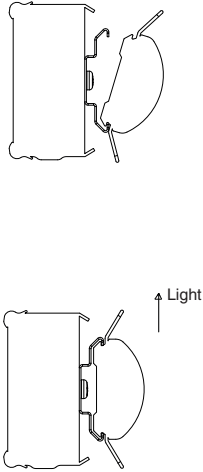
	<ol style="list-style-type: none">1. Align the LED light with the mounting clips so that the LEDs are facing the display case interior. Snap the LED light into the mounting clips:<ol style="list-style-type: none">a. By placing one end of the LED light into the groove.b. Gently rotate until the opposite edge firmly locks into the mounting clip.<p>NOTE: Ensure that the mounting clips lock into the outer edge of the LED light aluminum extrusion.</p><ol style="list-style-type: none">c. Adjust the lamp position until it is centered on the Mullion.2. Go to „Locking LED Fixture to Center Mullion Fixture“.
---	--

Locking LED Fixture to Center Mullion Fixture

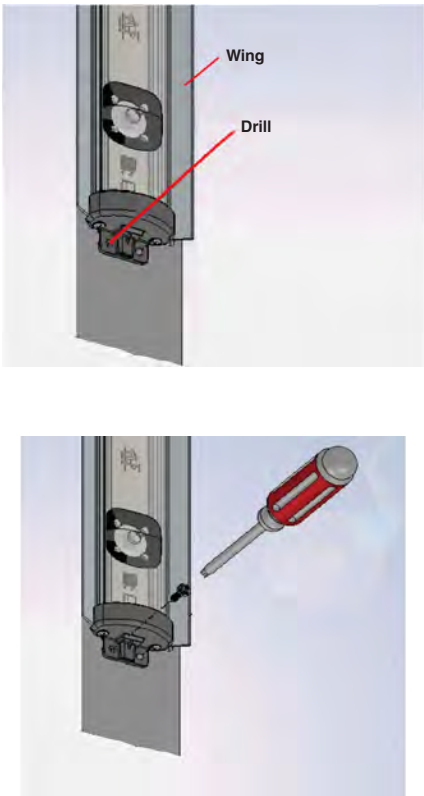
	<ol style="list-style-type: none">1. Using a (#29) 0.136 dia. drill bit, drill a hole through the LED Lighting fixture and through the Center Mullion Fixture.2. Using a Phillips screw driver to start threading the #8 X 1" long self-tapping screw to hold the end cap to the Center Mullion.3. Continue to "CONNECTING THE WIRE PLUG ASSEMBLY TO THE LED FIXTURE WIRES" on page 11.
---	---

Orientation Of End Fixtures

Refer to "WIRING DIAGRAMS and ORIENTATION" on page 14

End Mullion LED Fixture Mounting Instructions

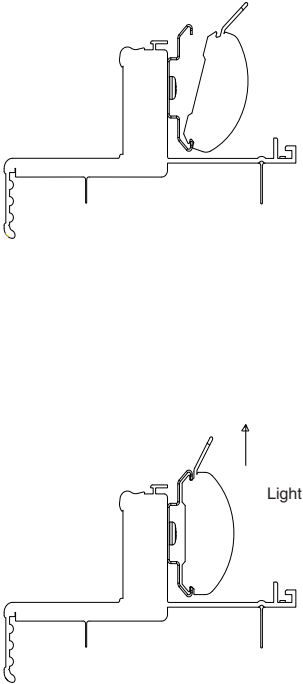
	<ol style="list-style-type: none">1. Align the LED light with the mounting clips so that the LEDs are facing the display case interior. Snap the LED light into the mounting clips:<ol style="list-style-type: none">a. By placing one end of the LED light into the groove.b. Gently rotate until the opposite edge firmly locks into the mounting clip.<p>NOTE: Ensure that the mounting clips lock into the outer edge of the LED light aluminum extrusion.</p><ol style="list-style-type: none">c. Adjust the LED lamp assembly until it is centered on the Mullion.2. Continue to "Locking LED Fixture to End Mullion Fixture" below.
--	---

Locking LED Fixture to End Mullion Fixture

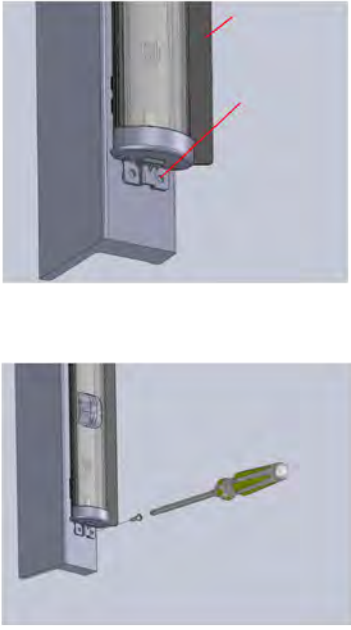
	<ol style="list-style-type: none">1. Using a (#29) 0.136 dia. drill bit, drill a hole through the bottom LED Lighting fixture through the End Mullion Fixture.2. Using a Phillips screw driver to start threading the #8 X 1" long self-tapping screw to hold the clip to the End Mullion fixture.3. Continue to "CONNECTING THE WIRE PLUG ASSEMBLY TO THE LED FIXTURE WIRES" on page 11.
---	---

Locking LED Fixture to Left End Mullion Fixture (Wires Connected at Top of Frame)

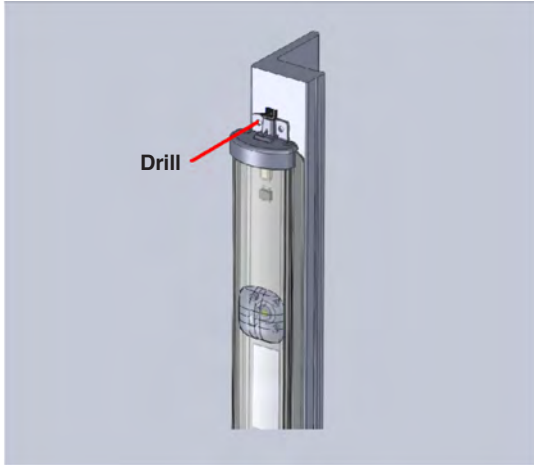

1. Using a (#29) 0.136 dia. drill bit, drill a hole through the LED Lighting fixture through the End Mullion Fixture.
2. Using a Phillips screw driver to start threading the #8 X 1" long self-tapping screw to hold the end cap to the End Mullion.
3. [Continue to "CONNECTING THE WIRE PLUG ASSEMBLY TO THE LED FIXTURE WIRES" on page 11.](#)

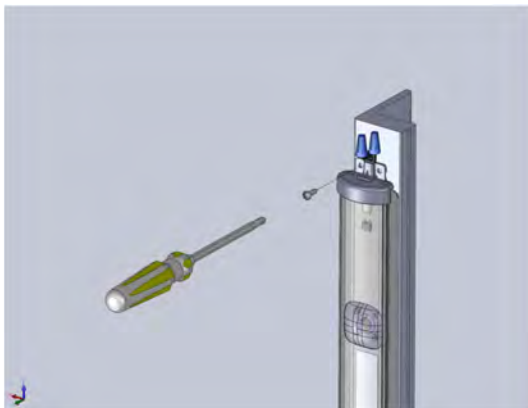

CONNECTING THE WIRE PLUG ASSEMBLY TO THE LED FIXTURE WIRES

Connecting Wires at the Bottom of the Frame

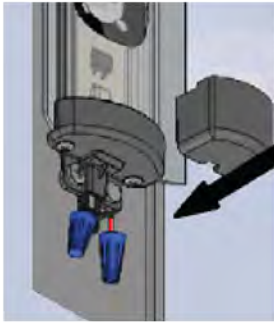

1. Connect wires from the fixture to the black and red wires from the 2-conductor harness using Wago Wall-NUT connector part number 773-162 or other approved connectors.

NOTE: Half power end fixtures need to be connected together. Refer to „WIRING DIAGRAMS and ORIENTATION” on page 14.

2. Tuck the wire connectors underneath the wire cover before snapping it to the end cap.
3. Make sure the wire cover is locked into the end cap.
4. Remove the protective film from the lens.
5. Seal off the cutouts in the Mullions using insulating material.
6. Go to „MOUNTING THE LED POWER SUPPLIES” on page 12.

Connecting Wires at the Top of the Frame

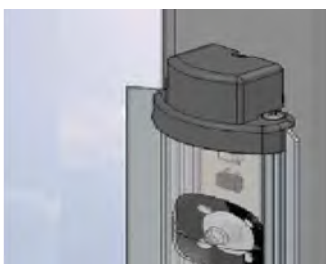
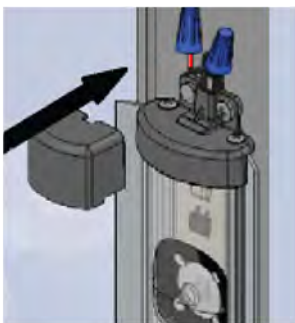

1. Connect wires from the fixture to the black and red wires from the 2-conductor harness (Refer to „RETROFIT PARTS LIST” on page 3) using Wago Wall-NUT connector part number 773-162 or other approved connectors.

NOTE: Half power end fixtures need to be connected together. Refer to „WIRING DIAGRAMS and ORIENTATION” on page 14.

2. Tuck the wire connectors underneath the wire cover before snapping it to the end cap.
3. Make sure the wire cover is locked into the end cap.
4. Remove the protective film from the lens.
5. Seal off the cutouts in the Mullions using insulating material.
6. Go to „MOUNTING THE LED POWER SUPPLIES” on page 12.

MOUNTING THE LED POWER SUPPLIES

Multi-Fixture Driver

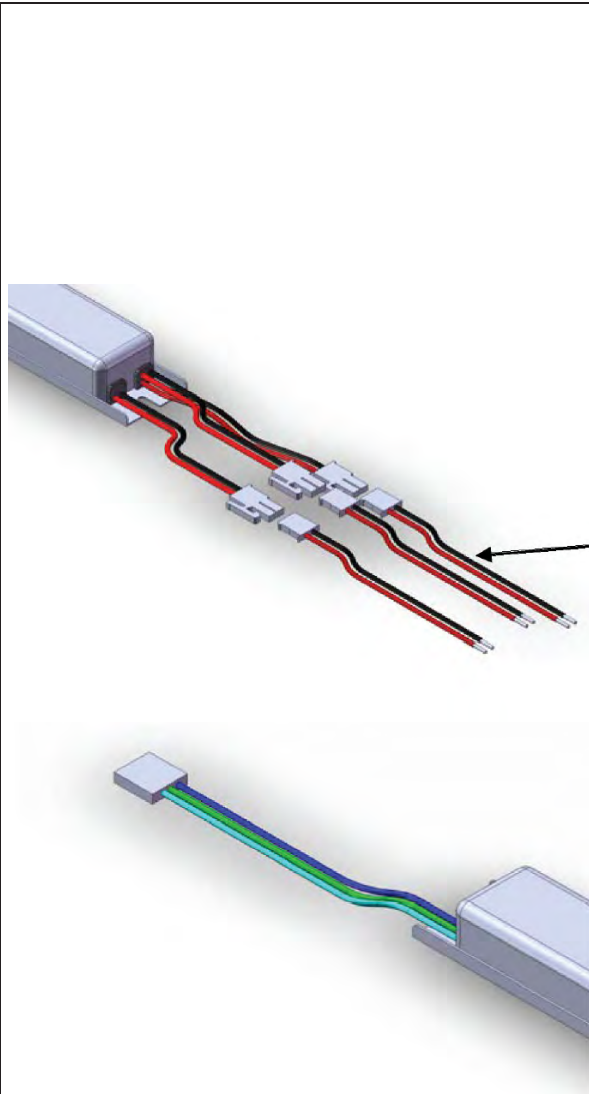

1. Install the LED power supply in the same location where the ballast was fitted or in the general location for ease of wire connection.
2. Mount the LED power supply using two #8 tapping screws saved when the ballast was removed.

NOTE: Installer may have to drill two holes in raceway to accommodate LED power supply.

NOTE: The LED power supply case is grounded. Attach the LED power supply to a ground point in the refrigerated case either directly with a screw or by using the green wire to attach to a remote point.

3. Connect LED Light fixture wire connectors to LED power supply using plug assembly provided. Refer to „RETROFIT PARTS LIST” on page 3.
4. Connect the 3-position plug on the primary side of the LED power supply as follows:
 - a. If a 3-position plug is present on the load wire harness go to [step 5](#).
 - b. If no 3-position plug is present on the load wire harness go [step 6](#).
5. Connect the primary LED power supply input 3-position plug (blue, green and white/blue wires) to the harness 120-240 VAC electrical 3-position plug (blue/white and white/blue wires). Go to [step 7](#).
6. If no 3-position plug is present on the load wire harness:
 - a. Cut off the 3-position plug on LED power supply.
 - b. Connect the blue (+) on LED power supply to the original load blue/white wire on the frame using a Wago Wall-NUT connector part number 773-162 or approved connector.
 - a. Connect the white/blue (-) on the LED power supply to the original load white/blue wire from the frame using a Wago Wall-NUT connector part number 773-162 or approved connector.
7. Reinstall raceway cover(s).
8. Turn power on and verify LED fixture(s) are working.

Single-Fixture Driver (Low Power and High Power)

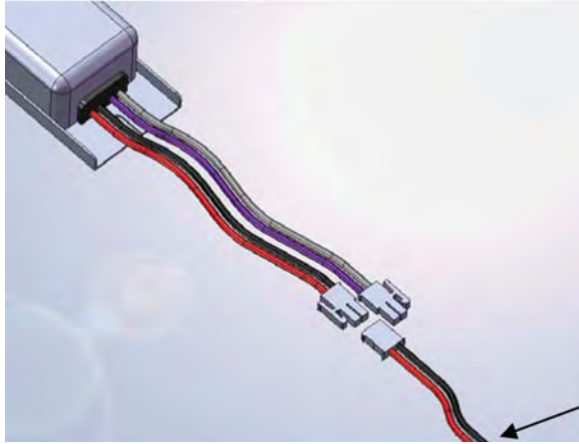

1. Install the LED power supply in the same location where the ballast was fitted or in the general location for ease of wire connection.
2. Mount the LED power supply using two #8 tapping screws saved when the ballast was removed.

NOTE: Installer may have to drill two holes in raceway to accommodate LED power supply.

NOTE: The LED power supply case is grounded. Attach the LED power supply to a ground point in the refrigerated case either directly with a screw or by using the green wire to attach to a remote point.

3. Connect LED Light fixture wire connectors to LED power supply using plug assembly provided. Refer to „RETROFIT PARTS LIST” on page 3.
4. Connect the 3-position plug on the primary side of the LED power supply as follows:
 - a. If a 3-position plug is present on the load wire harness go to [step 5](#).
 - b. If no 3-position plug is present on the load wire harness go [step 6](#).
5. Connect the primary LED power supply input 3-position plug (blue, green and white/blue wires) to the harness 120-240 VAC electrical 3-position plug (blue/white and white/blue wires). Go to [step 7](#).
6. If no 3-position plug is present on the load wire harness:
 - a. Cut off the 3-position plug on LED power supply.
 - b. Connect the blue (+) on LED power supply to the original load blue/white wire on the frame using a Wago Wall NUT connector part number 773-162 or approved connector.
 - a. Connect the white/blue (-) on the LED power supply to the original load white/blue wire from the frame using a Wago Wall-NUT connector part number 773-162 or approved connector.
7. Reinstall raceway cover(s).
8. Turn power on and verify LED fixture(s) are working.

WIRING DIAGRAMS and ORIENTATION

TYPICAL CONFIGURATION WITH SINGLE-FIXTURE DRIVER, 4-DOOR SHOWN

Half-Power Ends Option

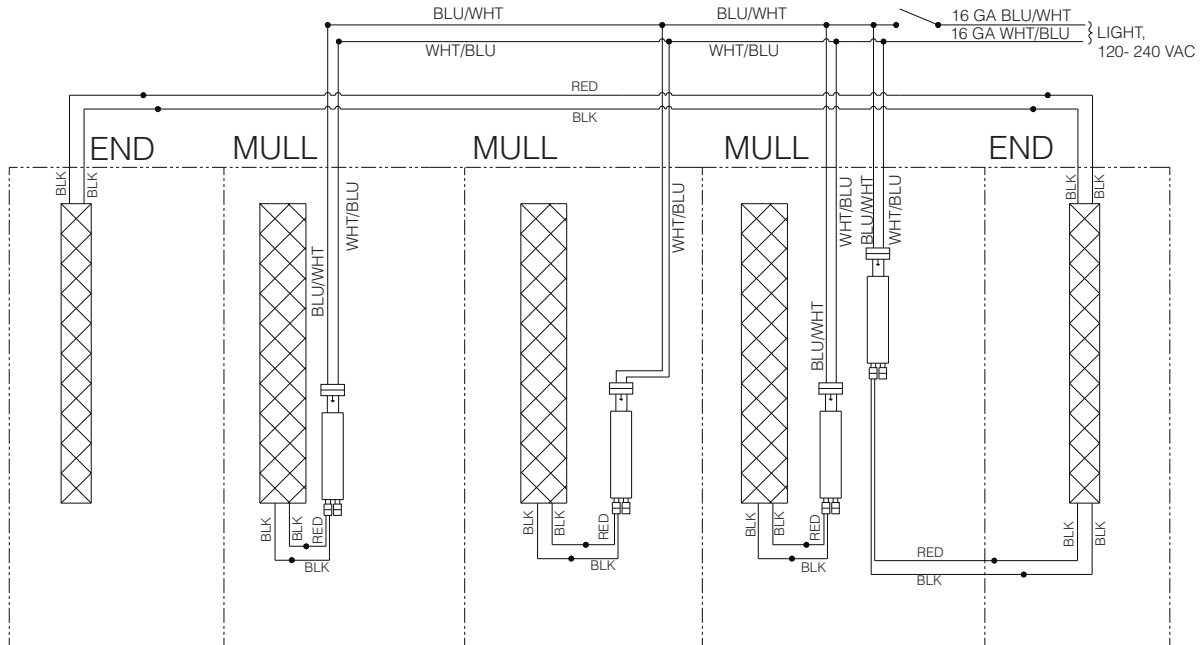

-0004 (4 - DOOR)

TYPICAL CONFIGURATION WITH MULTI-FIXTURE DRIVER, 4-DOOR SHOWN

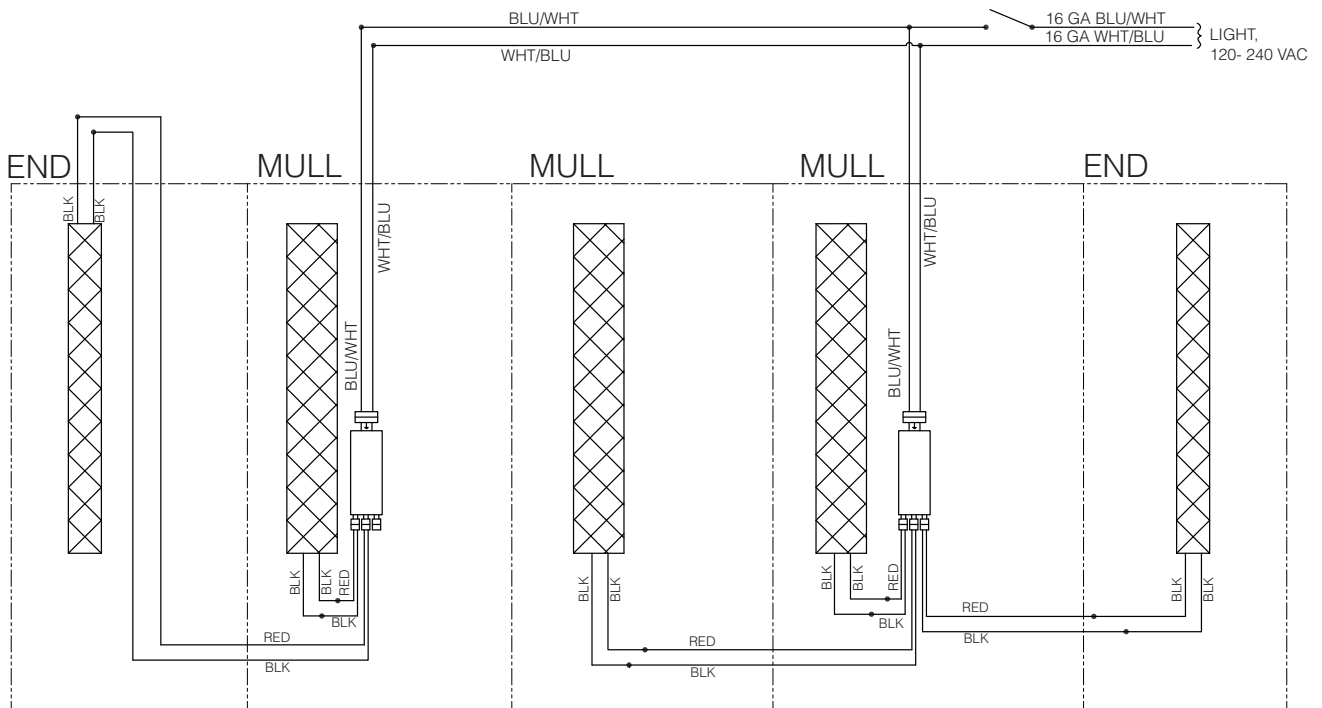

-0004 (4 - DOOR)

OPTIONAL CONFIGURATION WITH FULL-POWER ENDS and SINGLE-FIXTURE DRIVER

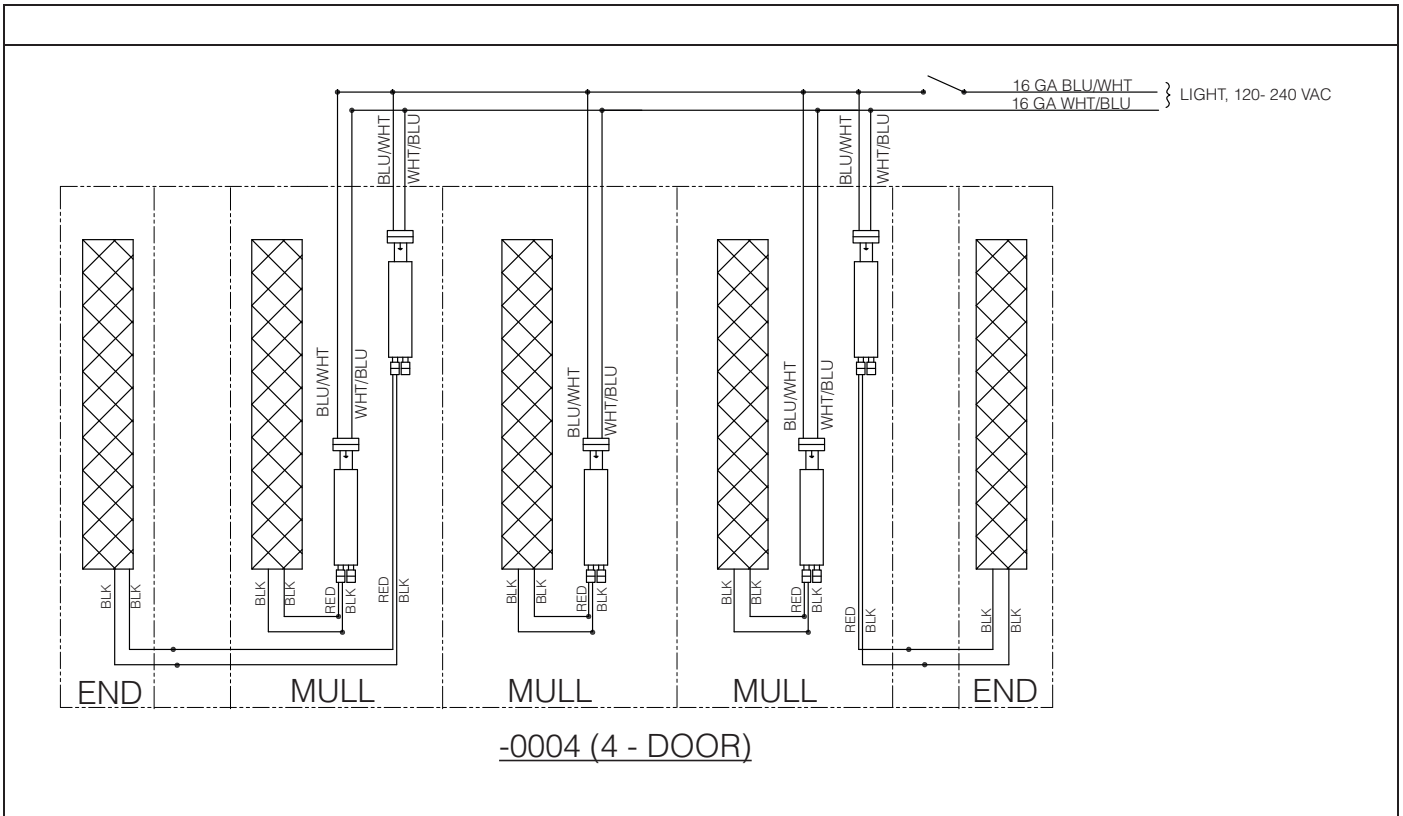

DETAILED RETROFIT INSTRUCTIONS FOR ANTHONY 401D, 1KDR, ELS, Ardco and Hussmann FRAMES

Optimax2 Retrofit Instructions for Anthony 401D and 1KDR with ELS Option	Refer to 99-18258-I001_A Optiplex2 Retrofit Instructions (Web Use) found on www.Anthonyintl.com
Ardco Frame	
Hussmann Frame	

LED CLEANING INSTRUCTIONS

- The LED light may be dusted as needed with a dry, clean, soft cloth.
- The outer lens should be cleaned periodically with a mild dish detergent.
- Do not use chemical cleaners to clean the system.
- Keep the outside clean. Wipe with a clean cloth lightly dampened with mild dish washer detergent. Dry with a clean, soft cloth
- Do not wipe the lens with a soiled dish cloth or wet towel. These may leave a residue that can damage the finish.
- Do not use scouring pads, powered cleaners, bleach or cleaners containing bleach because these products can scratch and damage the finish.



HUSSMANN[®]

**To obtain warranty information
or other support, contact your
Hussmann representative.
Please include the model and
serial number of the product.**

Hussmann Corporation, Corporate Headquarters: Bridgeton, Missouri, U.S.A. 63044-2483 01 October 2012

Husmann Corporation

12999 St. Charles Rock Road
Bridgeton, MO 63044-2483
www.husmann.com