

Medium Temperature Self Contained
Horizontal Merchandiser with R-290 Refrigerant



Installation & Operation Manual

WARNINGS:

- » If the information in these instructions are not followed exactly, a fire or explosion may result, causing property damage, personal injury or death.
- » Installation and service must be performed by a qualified installer or service agency.
- » **READ THE ENTIRE MANUAL BEFORE INSTALLING OR USING THIS EQUIPMENT.**
- » The unit uses R-290 gas as the refrigerant. R-290 is flammable and heavier than air. It collects first in low areas but can be circulated by the fans. If propane gas is present or even suspected, do not allow untrained personnel to attempt to find the cause. The propane gas used in the unit has no odor. The lack of smell does not indicate a lack of escaped gas. If a leak is detected, immediately evacuate all persons from the store, and contact the local fire department to advise them that a propane leak has occurred. Do not let any persons back into the store until the qualified service technician has arrived and that technician advises that it is safe to return to the store. No open flames, cigarettes, or other possible sources of ignition should be used inside or in the vicinity of the units.
- » **FAILURE TO ABIDE BY THIS WARNING COULD RESULT IN AN EXPLOSION, DEATH, INJURY AND PROPERTY DAMAGE.**

ISMGG2DA-A

August 2023
P/N 3110586_E
Spanish P/N 3110587
MANUAL - IO ISMGG2DAA

BEFORE YOU BEGIN

READ THESE INSTRUCTIONS COMPLETELY AND CAREFULLY.

This manual was written in accordance with originally prescribed equipment that is subject to change. Hussmann reserves the right to change or revise specifications and product design in connection with any feature of our products.

SAFETY INSTRUCTIONS



Personal Protection Equipment (PPE) is required. Wear safety glasses, gloves, protective boots or shoes, long pants, and a long-sleeve shirt when working with this equipment and while handling glass.

SAFETY INSTRUCTIONS

The safety of our customers and employees is paramount. The precautions and procedures described in this manual are intended as general methods for safe use of this equipment. Please be sure to comply with the precautions described in this manual to protect you and others from possible harm.

1. If the information in these instructions are not followed exactly, a fire or explosion may result, causing property damage, personal injury or death. Observe all precautions on tags, stickers, labels and literature attached to this equipment.
2. Installation and service must be performed by a qualified installer or service agency.
3. This unit is designed only for use with R-290 gas as the designated refrigerant.

⚠ WARNING

THE REFRIGERANT LOOP IS SEALED. ONLY A QUALIFIED TECHNICIAN SHOULD ATTEMPT TO SERVICE!

- Propane is flammable and heavier than air.
- It collects first in the low areas but can be circulated by the fans.
- If R-290 is present or even suspected, do not allow untrained personnel to attempt to find the cause.
- The propane gas used in the unit has no odor.
- The lack of smell does not indicate a lack of escaped gas.
- If a leak is detected, immediately evacuate all persons from the store, and contact the local fire department to advise them that a propane leak has occurred.
- Do not let any persons back into the store until the qualified service technician has arrived and that technician advises that it is safe to return to the store.
- A hand-held propane leak detector ("sniffer") shall be used before any repair and/or maintenance.
- No open flames, cigarettes or other possible sources of ignition should be used inside the building where the units are located until the qualified service technician and/or local fire department determines that all propane has been cleared from the area and from the refrigeration systems.
- Component parts are designed for propane and non-incendive and non-sparking. Component parts shall only be replaced with identical repair parts.

FAILURE TO ABIDE BY THIS WARNING COULD RESULT IN AN EXPLOSION, DEATH, INJURY AND PROPERTY DAMAGE.

ANSI Z535.5 DEFINITIONS

The definitions below are used to clarify the magnitude and urgency of harm and damage, considering problems arising from misuse. Relative to their potential danger, the definitions are divided into five parts according to ANSI Z535 Series.



DANGER indicates a hazardous situation which, if not avoided, will result in death or serious injury.



WARNING indicates a hazardous situation which, if not avoided, could result in death or serious injury.



CAUTION indicates a hazardous situation which, if not avoided, could result in minor or moderate injury.



NOTICE is used to address practices not related to personal injury.



SAFETY INSTRUCTIONS (or equivalent) signs indicate specific safety-related instructions or procedures.

REVISION HISTORY

Revision E: Added note page 3-7

Revision D: Updated thermometer section and added troubleshooting pages.

Revision C: redesigned manual and updated case drawings

Revision B: Updated sensor locations and set points

ORIGINAL ISSUE — FEBRUARY 2020

FOR CALIFORNIA INSTALLATIONS ONLY:

WARNING:

Cancer and Reproductive Harm
www.P65Warnings.ca.gov

August 31, 2018

This warning does not mean that Hussmann products will cause cancer or reproductive harm, or is in violation of any product-safety standards or requirements. As clarified by the California State Government, Proposition 65 can be considered more of a 'right to know' law than a pure product safety law. When used as designed, Hussmann believes that our products are not harmful. We provide the Proposition 65 warning to stay in compliance with California State law.

It is your responsibility to provide accurate Proposition 65 warning labels to your customers when necessary. For more information on Proposition 65, please visit the California State Government Website.

WARNING

- » Excessive ambient conditions may cause condensation and therefore sweating of doors. Facility operators should monitor doors and floor conditions to ensure safety of persons.
- » Case ventilation openings must be clear of any obstructions. Do not damage the refrigerant circuit.
- » Always disconnect the electrical power at the main disconnect when servicing or replacing any electrical component. This includes, but is not limited to, such items as fans, heaters, thermostats and lights.
- » Do not use mechanical devices or other means to accelerate the defrosting process.
- » Do not use electrical appliances inside the food storage compartments of the case(s).
- » Do not store items or flammable materials atop the unit. Do not walk on case.

TABLE OF CONTENTS

BEFORE YOU BEGIN	II
Read these instructions completely and carefully.	ii
Safety Instructions	ii
ANSI Z535.5 Definitions.....	iii
Revision History.....	iii
Table of Contents.....	iv

INSTALLATION	1-1
Model Description	1-1
UL Listing.....	1-1
Federal / State Regulation	1-1
Hussmann Product Control	1-1
Shipping Damage	1-1
Location.....	1-1
Self Contained Location.....	1-2
Unloading	1-3
Exterior loading	1-3
Shipping Skid / Crate.....	1-3
Merchandiser Leveling.....	1-6
Serial Plate Location.....	1-6
Sealing Merchandiser to Floor	1-6
Condensing Unit Access	1-7
Self-Contained Refrigeration Equipment Start-up Checklist	1-9
Legal Disclaimer	1-9

ELECTRICAL / REFRIGERATION	2-1
Merchandiser Electrical Data	2-1
Field Wiring.....	2-1
Electrical Connections	2-1
Electrical Outlet	2-1
Refrigeration	2-1
Before Beginning Any Service or Repair:	2-2
Replacing Refrigeration System Components.....	2-3
Steps to Recover Refrigerant	2-3
Charging.....	2-3
Water Outlet and Water Seal	2-4

CONTROLLER	3-1
Controller Operation	3-1
Key Functions:	3-2
Connections	3-3
LED Indications	3-4
KDEPlus Buttons.....	3-5
Set Points	3-6
Sensor Location\	3-7
Controls and Adjustments	3-8
Instructions to Change RTN Case Controller Settings	3-8

START UP / OPERATION	4-1
Start Up.....	4-1
Load Limits	4-1
Stocking	4-1
Thermometer	4-1

MAINTENANCE	5-1
Care and Cleaning	5-1
Cleaning Discharge Honeycomb	5-2
Cleaning Thermometer	5-2
Cleaning Coils	5-2
Cleaning Evaporation Pan	5-3
Removing Scratches from Bumper	5-3
Self-Contained Refrigeration Equipment Maintenance Check List	5-4

SERVICE	6-1
Replacing Condenser Fan Motors and Blades	6-1
Replacing Fan Motors and Blades	6-2
Troubleshooting.....	6-3
Warranty Information	6-5

INSTALLATION

MODEL DESCRIPTION

ISMGG2DAA merchandisers offer versatility for the display of food items such as: fresh fruit, vegetables, cheeses and other delicatessen items. Carefully read and follow the instructions prior to operating the merchandiser.

UL LISTING

These merchandisers are manufactured to meet ANSI/ UL 471 standard requirements for safety. Proper installation is required to maintain the listing.

FEDERAL / STATE REGULATION

These merchandisers at the time they are manufactured, meet all federal and state/ provincial regulations. Proper installation is required to ensure these standards are maintained. Near the serial plate, each merchandiser carries a label identifying the environment for which the merchandiser was designed for use. For Example:

ANSI/NSF-7 Type I – Display Refrigerator / Freezer

Intended for 75°F (24°C) / 55%RH Ambient Application

ANSI/NSF-7 Type II – Display Refrigerator / Freezer

Intended for 80°F / 55%RH Ambient Application

ANSI/NSF-7 – Display Refrigerator

Intended for Bulk Produce

HUSSMANN PRODUCT CONTROL

The serial number and shipping date of all equipment is recorded in Husmann's files for warranty and replacement part purposes. All correspondence pertaining to warranty or parts ordering must include the serial number of each piece of equipment involved. This is to ensure the customer is provided with the correct parts.

SHIPPING DAMAGE

All equipment should be thoroughly examined for shipping damage before and during unloading. This equipment has been carefully inspected at our factory. Any claim for loss or damage must be made

to the carrier. The carrier will provide any necessary inspection reports and/or claim forms.

Apparent Loss or Damage

If there is an obvious loss or damage, it must be noted on the freight bill or express receipt and signed by the carrier's agent; otherwise, carrier may refuse claim.

Concealed Loss or Damage

When loss or damage is not apparent until after equipment is uncrated, retain all packing materials and submit a written response to the carrier for inspection within 15 days.

Recommended operating ambient temperature is between 65°F (18°C) to 75°F (23.9°C). Maximum relative humidity is 55%.

LOCATION

These merchandisers are designed for displaying products in air conditioned stores where temperature is maintained at or below the ANSI / NSF-7 specified level and relative humidity is maintained at or below 55%. Placing refrigerated merchandisers in direct sunlight, near hot tables or near other heat sources could impair their efficiency. Like other merchandisers, these merchandisers are sensitive to air disturbances. **Air currents passing around merchandisers will seriously impair their operation.** DO NOT allow air conditioning, electric fans, open doors or windows, etc. to create air currents around the merchandiser.

⚠️ WARNING

All installation and operating instructions concerning the handling, moving, and use of these merchandisers must be carefully followed to avoid either damaging the refrigerant tubing, or increasing the risk of a leak.

SELF CONTAINED LOCATION

Product should always be maintained at proper temperature. This means that from the time the product is received, through storage, preparation and display, the temperature of the product must be controlled to maximize the life of the product.

Self Contained models have vented base panels to allow air circulation through the condensing unit.

See illustrations for clearances distances from walls, merchandisers, and any other large objects near the merchandiser's vented base panels. Blocking or restricting air flow will adversely affect performance and may damage the refrigeration system.

These models need clearance a minimum of 1 inch on each side and at the back of the unit.

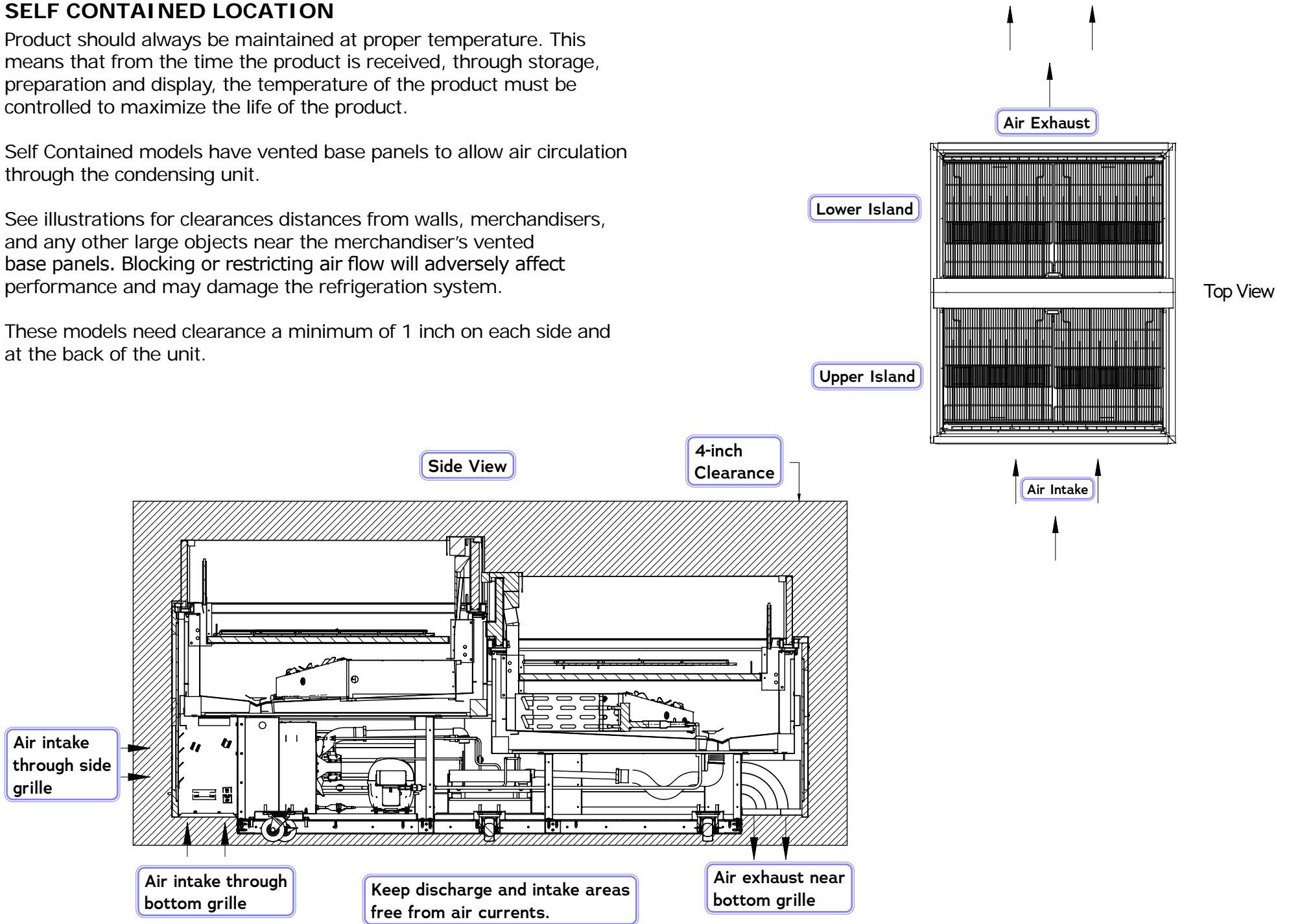

UNLOADING

Unloading from Trailer:

Lever Bar (also known as a Mule, Johnson Bar, J-bar, Lever Dolly, or Pry Lever)

Move the merchandiser as close as possible to its permanent location and remove all packaging. Check for damage before discarding packaging. Remove all separately packed accessories such as kits and shelves.

Improper handling may cause damage to the merchandiser when unloading. To avoid damage:

1. Do not drag the merchandiser out of the trailer. Use a Johnson bar (mule).
2. Use a forklift or dolly to remove the merchandiser from the trailer.

EXTERIOR LOADING

Do NOT walk on top of merchandisers or damage to the merchandisers and serious personal injury could occur. Do not stand inside of merchandiser.

⚠️ WARNING

Do NOT stand or walk on top of merchandiser. Do not store flammable items or flammable materials atop the unit.

SHIPPING SKID / CRATE

Each merchandiser is shipped on a skid to protect the merchandiser's base, and to make positioning the case easier.

Do not remove the shipping skid until the merchandiser is near its final location. The skid provides protection for both the merchandiser and the floor.

DO NOT TILT MERCHANDISER ON ITS SIDE OR END WHEN REMOVING SKID.

Once the skid is removed, the merchandiser must be lifted — **NOT PUSHED**— to reposition.

Check floor where merchandisers are to be set to see if it is a level area. Determine the highest part of the floor.

To remove the shipping crate do the following:

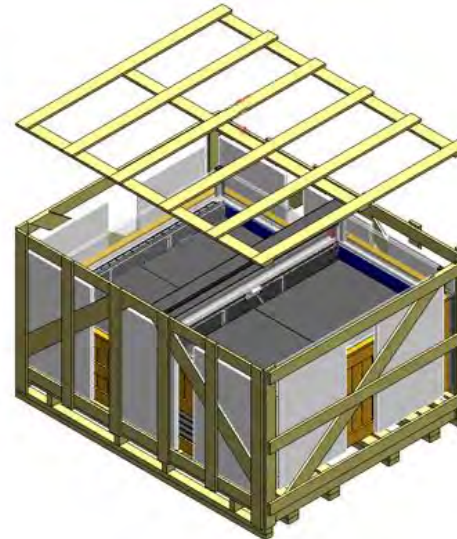

⚠️ WARNING

Do NOT remove shipping crate until the merchandiser is positioned for installation.

1. Use a cordless screwdriver to remove the screws attached at the sides, front and rear of the crate.

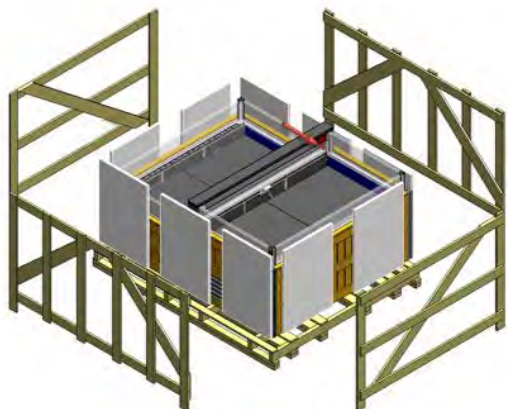

2. Remove the protector plastic bag, which is covering the case. Carefully remove the strapping wrapped around the case. Remove white protectors around the case (10 pieces).

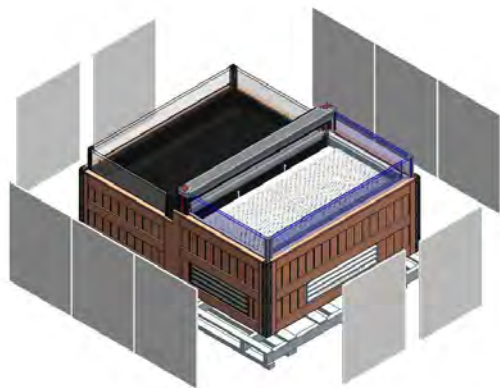

3. Remove the frontal screws from the skid-crate brackets. (4 brackets total).

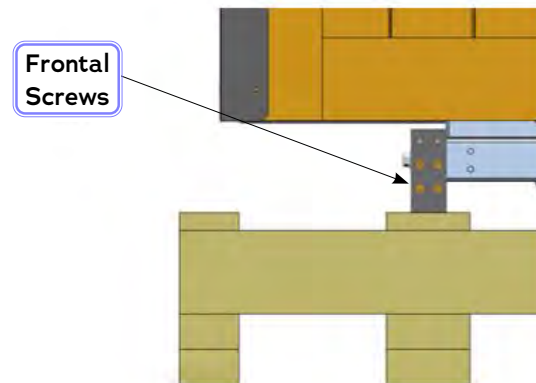

4. Identify the taller case. Remove the case from the skid with a forklift. Set the forks below the taller case base, between rail base and wood skid. Maximum fork opening is 29 1/2 inches in order to avoid damaging the casters.

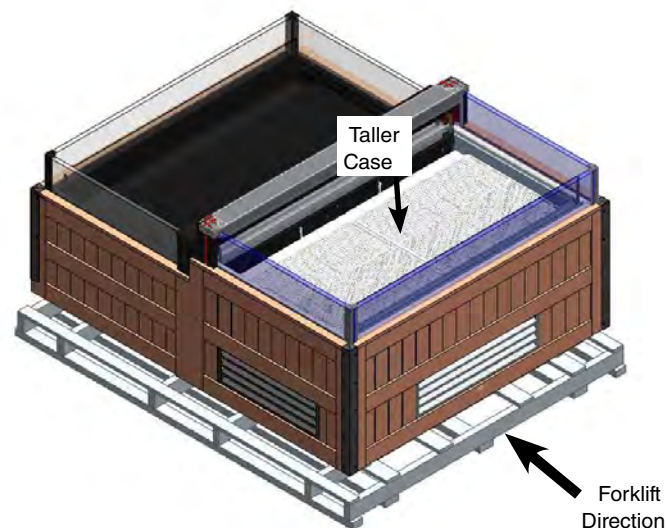

The power cord is located below the frontal baffle, taller case, attached with cable ties.



Power Cord

5. Lift case with forklift, and remove the screws from the shipping braces (both sides of the case) in order to set the case to its final location.

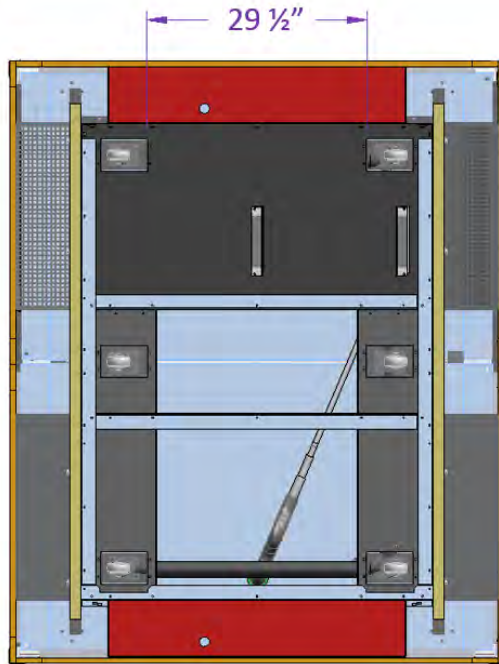
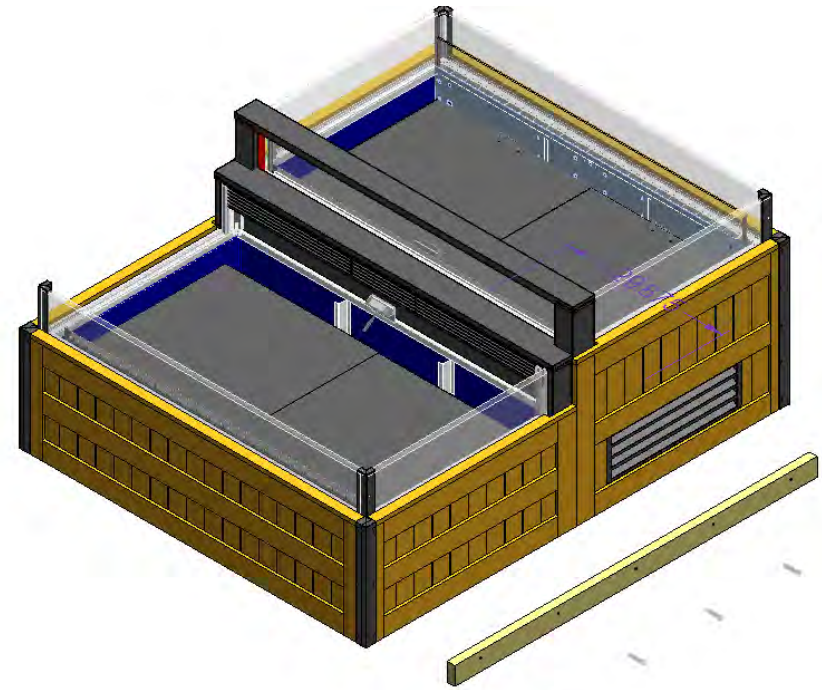

Maximum Forklift Opening is 29 1/2 inches

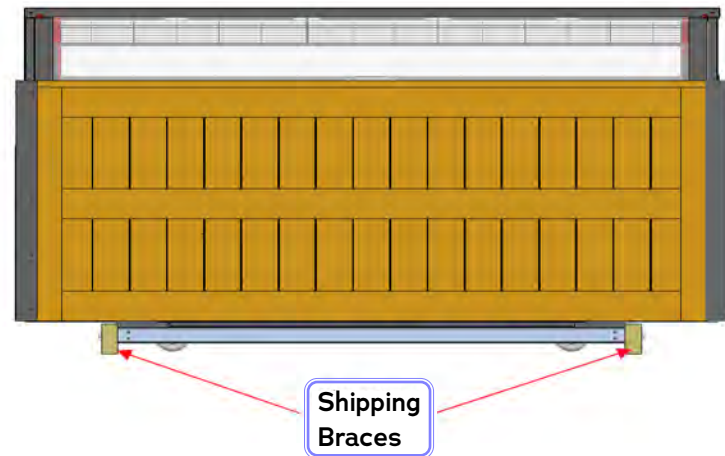

Shipping Braces

MERCHANDISER LEVELING

Be sure to position merchandisers properly. Level the merchandiser by all four corners. Merchandiser(s) must be installed level to ensure proper operation of the refrigeration system, and to ensure proper drainage of defrost water.

SERIAL PLATE LOCATION

The serial plate is located on the inside of the merchandiser's display area near the return air.

NOTE:

Impacts from shopping carts can cause wood to wear, cracks, chipping or peeling. To avoid these impacts, it is required to install a floor bumper (or alike) around the case or other type of protection to prevent damage to the wood.

Serial Plate

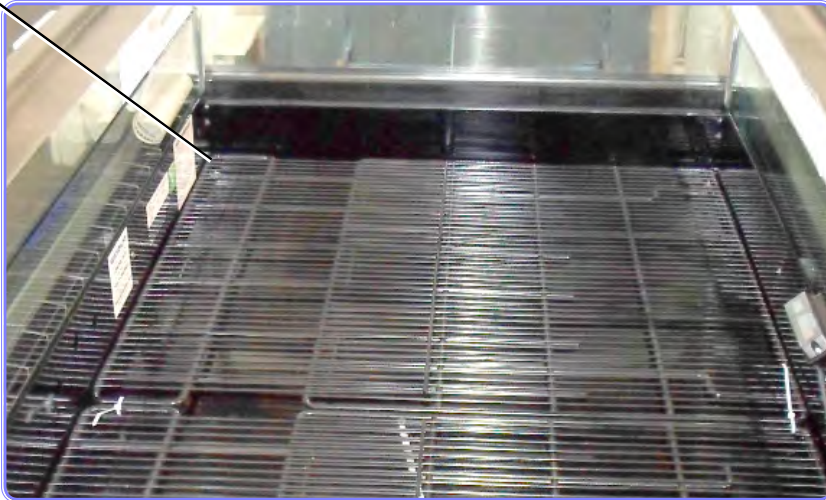

SEALING MERCHANDISER TO FLOOR

If required by local sanitary codes, or if the customer desires, merchandisers may be sealed to the floor using a vinyl cove base trim. The size needed will depend on how much variation there is in the floor, from one end of the merchandiser to the other. Sealing of the lower front and rear panels on self contained models may hamper their removal for servicing or maintenance of the condensing unit.

NOTE:

Do not allow trim to cover any intake or discharge grilles located in the lower front panel.

ATTENTION

Merchandiser must operate for 24 hours before loading product!

Regularly check merchandiser temperatures.

Do not break the cold chain. Keep products in cooler before loading into merchandiser.

These merchandisers are designed for only pre-chilled products.

CONDENSING UNIT ACCESS

To access the condensing unit and electrical box, it is necessary to remove the wood panel front and wood panel end (LH).

To do this:

1. Using a screwdriver or cordless drill, remove all the screws from Corner High Side (LH).
2. Remove screws from corner low side (LH), only the ones attached to wood panel end (LH).
3. Carefully pull the wood panel end (LH) to the right to have access to the (LH) condensing unit.

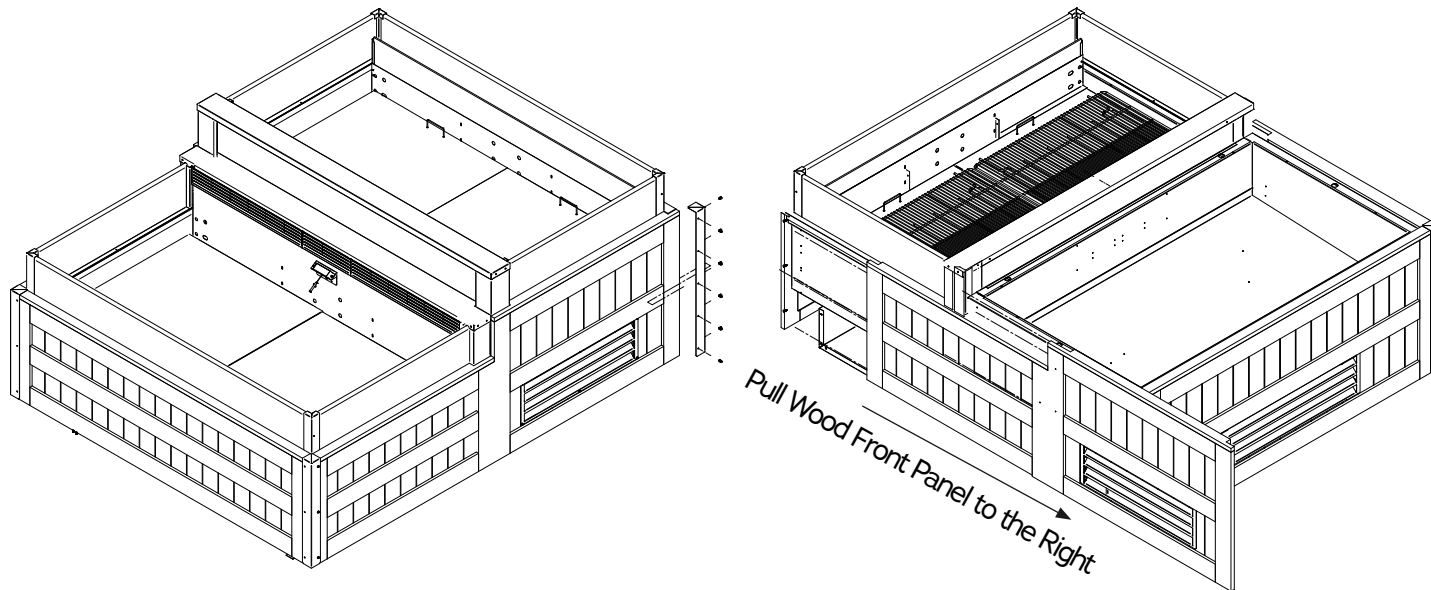
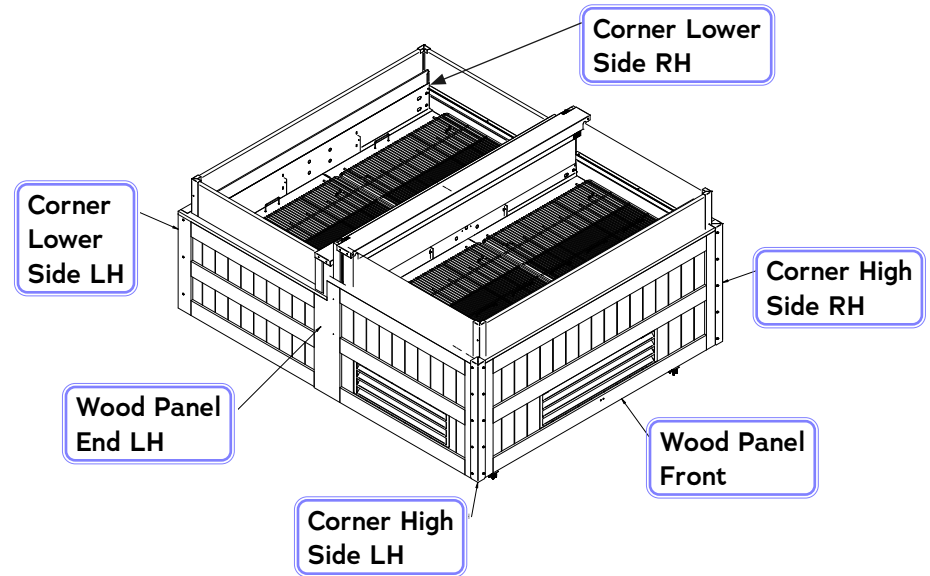

Remove screws from corner high side (RH), only the ones attached to wood panel front.

4. Carefully pull the wood panel front to the left to access the condensers.

5. Remove screws from low side corner (RH), and carefully pull the wood panel end (LH) to the left to access the (RH) condensing unit.

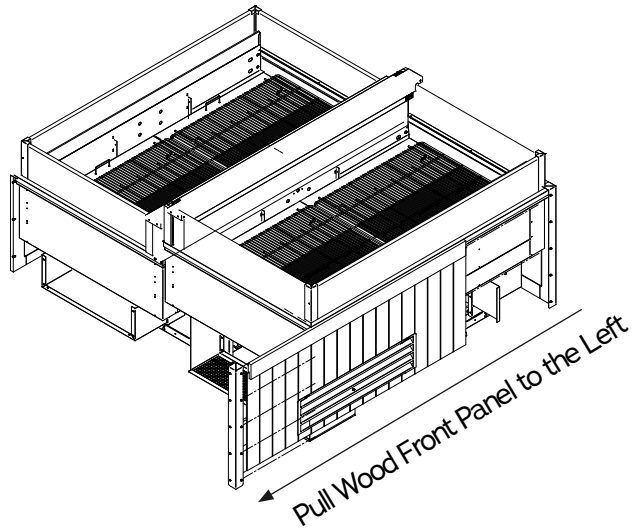

Front View

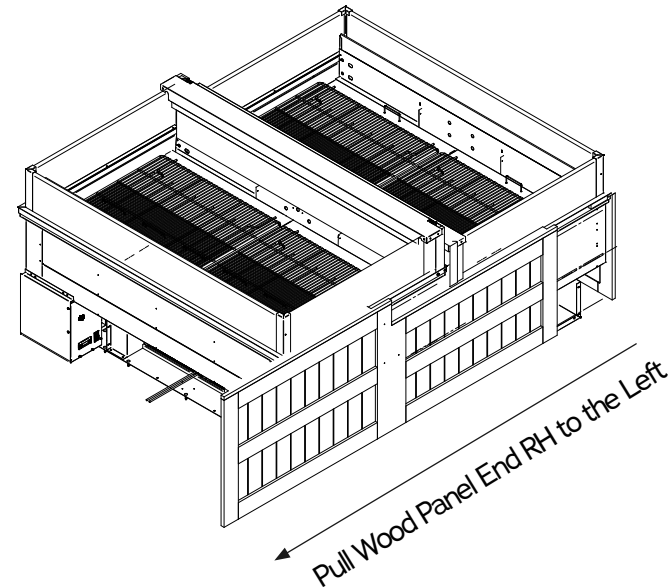
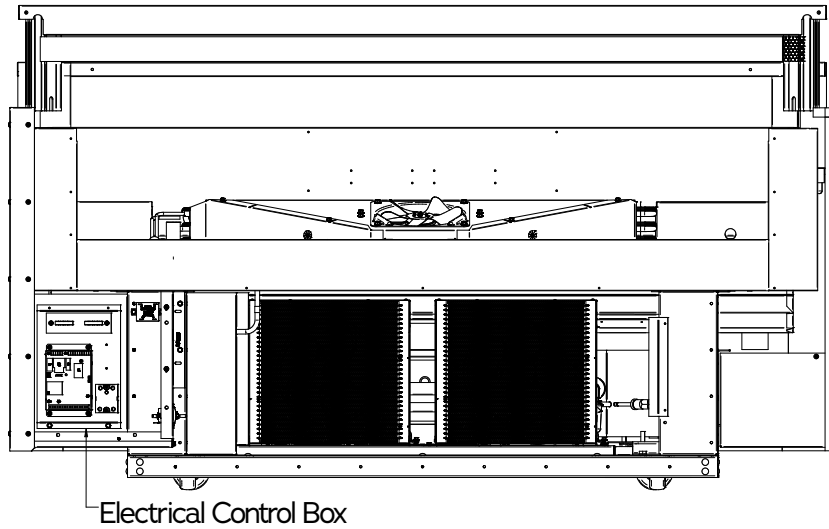
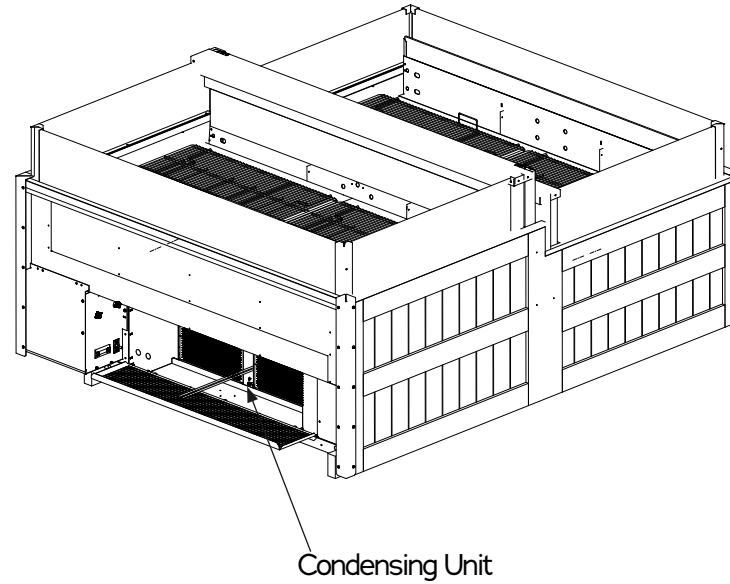

SELF-CONTAINED REFRIGERATION EQUIPMENT START-UP CHECKLIST

Step	Startup Activity	Check
1	Locate, read and maintain install/operation manual in a safe place for future reference.	<input type="checkbox"/>
2	Examine unit. Confirm there is NO damage or concealed damage.	<input type="checkbox"/>
3	Level the unit, side to side and front to rear.	<input type="checkbox"/>
4	Remove all shipping brackets/compressor straps/bolts etc.	<input type="checkbox"/>
5	Unit must be run on a dedicated electrical circuit without the use of an extension cord.	<input type="checkbox"/>
6	Ensure that the proper electrical requirements for the equipment are supplied.	<input type="checkbox"/>
7	Verify field electrical connections are tight.	<input type="checkbox"/>
8	Verify all electrical wiring is secured and clear of any sharp edges or hot lines.	<input type="checkbox"/>
9	Verify the condensate drain line is properly trapped and pitched.	<input type="checkbox"/>
10	Verify all required clearances on the sides and back of unit.	<input type="checkbox"/>
11	Verify there are no air disturbances external to the unit. Heat and air registers, fans, and doors etc.	<input type="checkbox"/>
Advise owner/operator that merchandiser must operate at temperature for 24 hrs prior to loading with product.		

Form HSCW01 Rev. 30MAY12 P/N 0525209_B

LEGAL DISCLAIMER

Hussmann shall not be liable for any repair or replacement made without the written consent of Hussmann, or when the product is installed or operated in a manner contrary to the printed instructions covering installation and service which accompanied such product.

Please note that failure to follow this start up document may void your factory warranty.

WARNING

— LOCK OUT / TAG OUT —

- » To avoid serious injury or death from electrical shock, always disconnect the electrical power at the main disconnect when servicing or replacing any electrical component. This includes, but is not limited to, such items as doors, lights, fans, heaters, and thermostats.

ELECTRICAL / REFRIGERATION

MERCHANDISER ELECTRICAL DATA

Refer to Appendix A of this manual or the merchandiser's serial plate for electrical information.

FIELD WIRING

Field wiring must be sized for component amperes stamped on the serial plate. Actual ampere draw may be less than specified.

**ALWAYS CHECK THE SERIAL PLATE FOR
COMPONENT AMPERES**

ELECTRICAL CONNECTIONS

All wiring must be in compliance with NEC and local codes. All electrical connections (for remote models) are to be made in the electrical Handy Box located behind the removable base panel at the left end of the merchandiser when facing the discharge air louver.

ELECTRICAL OUTLET

Before the merchandiser is connected to any wall circuit, use a voltmeter to check that the outlet is at 100% of the rated voltage. The wall circuit must be dedicated for the merchandiser. Failure to do so voids the warranty. Do not use an extension cord. Never plug in more than one merchandiser per electrical circuit.

- **Always use a dedicated circuit with the amperage stated on the unit.**
- **Plug into an outlet designed for the plug.**
- **Do not overload the circuit**
- **Do not use long or thin extension cords. Never use adapters.**
- **If in doubt, call an electrician.**

Self-contained models have factory-installed power cords attached at the electrical box.



NEMA 5-15P
Electrical Plug

⚠️ WARNING

- » Risk of Electric Shock. If cord or plug becomes damaged, replace only with a cord and plug of the same type.
- » Merchandiser must be grounded.
- » Do not remove the power supply cord ground.

REFRIGERATION

Each self contained model is equipped with its own condensing unit and control panel located beneath the display area.

The merchandiser refrigeration piping is leak tested. The unit is charged with refrigerant and shipped from the factory with all service valves open. All models have a hermetic compressor. The systems employ capillary tubes for refrigerant flow control.

BEFORE BEGINNING ANY SERVICE OR REPAIR:

Use a hand-held propane leak detector (“sniffer”) to ensure no propane is present in the immediate area, the inside of the display case and the inside of the refrigeration system. R-290 is an odorless refrigerant. Keep the area clear of all customers and non-essential or unauthorized personnel.

Verify that all repair parts are identical models to the ones they are replacing. Do not substitute parts such as motors, switches, relays, heaters, compressors, power supplies or solenoids. Failure to do so can result in an explosion, death, injury and property damage. Parts used on hydrocarbon cases must meet specific UL certification for non-incendive or non-sparking components. Use only Hussmann approved parts approved through the Hussmann Performance Parts Website. <https://parts.hussmann.com/>

Brazing must not begin before all propane has been cleared from the immediate area — the inside of the displays case and the inside of the refrigeration system.

If a leak is detected, follow store safety procedures. It is the store’s responsibility to have a written safety procedure in place. The safety procedure must comply with all applicable codes such as local fire department’s codes.

At minimum, the following actions are required:

- **Immediately evacuate all persons from the store, and contact the local fire department to advise them that a propane leak has occurred.**
- **Call Hussmann and/or a qualified service agent and inform them that a propane sensor has detected the presence of propane.**
- **Do not let any persons back into the store until the qualified service technician has arrived and that technician advises that it is safe to return to the store.**
- **The propane gas used in the unit has no odor. The lack of smell does not indicate a lack of escaped gas.**

- **A hand-held propane leak detector**
- **(“sniffer”) should be used before any repair and/or maintenance is attempted. All repair parts must be identical models to the ones they are replacing.**
- **No open flames, cigarettes or other possible sources of ignition should be used inside the building where the units are located until the qualified service technician and/or local fire department determines that all propane has been cleared from the area and from the refrigeration systems.**

DANGER

- » Only Hussmann or factory trained technicians should service or repair this R-290 (propane) equipment.
- » Failure to follow instructions can result in an explosion, death, injury and property damage.

REPLACING REFRIGERATION SYSTEM COMPONENTS

⚠ DANGER

- » Only Hussmann service technicians or technicians qualified to handle R-290 (propane) refrigerant should service or repair this R-290 (propane) equipment.
- » Failure to follow instructions can result in an explosion, death, injury and property damage.

STEPS TO RECOVER REFRIGERANT

1. Make sure you are in a well ventilated area before making any service or repair to the refrigeration system.
2. Disconnect all power sources from the system. Some systems may have more than one plug or power supply.
3. Tap system with line tap valves, attaching gauges to the high and low sides of the system.



refrigeration
line tapping
valve

4. Connect hose to an evacuated recovery tank. Open refrigeration gauges and recovery tank.
5. With the suction valve in vacuum, the refrigerant will be recovered into the recovery tank.

6. Once recovered, close the tank valve and remove the gauge from the tank and connect nitrogen tank to the system to purge it with nitrogen.
7. Pull vacuum to a minimum of 200 microns or lower.



CHARGING

A calibrated scale with +/-2 gram accuracy must be used to charge the system. The charge amount is shown on the serial plate. Only R-290 grade refrigerant can be used. Standard propane does not meet the purity/moisture content of R-290, and therefore cannot be used to charge cases.

No gas charge adjustments are allowed. When connecting hoses between the refrigeration system, manifold gauges, and refrigerant cylinder, ensure that the connections are secure and there are no potential sources of ignition nearby. Ensure that contamination of different refrigerants does not occur when using charging equipment.

⚠ WARNING

— LOCK OUT / TAG OUT —

- » To avoid serious injury or death from electrical shock, always disconnect the electrical power at the main disconnect when servicing or replacing any electrical component. This includes, but is not limited to, such items as doors, lights, fans, heaters, and thermostats.

Use dedicated hoses to service R-290 (propane) refrigeration systems. Hoses or lines should be as short as possible to minimize the amount of refrigerant contained in them.

Ensure that the refrigeration system is properly grounded prior to charging the system with refrigerant, to avoid the potential for static build-up.

Extreme care must be taken not to over fill the refrigeration system. After charging, carefully disconnect the hoses, attempting to minimize the quantity of refrigerant released. Further leak check the service ports, hoses, refrigerant tanks. The service ports shall be checked for leaks using a hydrocarbon leak detector with a sensitivity of 3 grams/year (0.106 Oz/year) leak rate.

Thoroughly leak check the service ports. If no leak is present, use a pinch-off tool to close the ends of the service tubes before brazing them shut. Remove all service ports. If a Schrader valve is used on the compressor service tube, it must be removed and the previous steps followed in order to braze the service tube shut.

⚠ WARNING

- » Component parts shall be replaced with like components, and servicing shall be done by factory authorized service personnel only, so as to minimize the risk of possible ignition due to incorrect parts or improper service.

WATER OUTLET AND WATER SEAL

The condensate water outlet is located in the center of the merchandiser. The outlet has a factory installed, external water seal.

For self contained models, this water seal drains into the condensate evaporator pan located beneath the merchandiser. Ensure the drain hose is properly trapped, and the drain area is not clogged.

NOTE:

All lower base panels must be in place when the refrigerator is operating. If not, airflow from the condenser will be directed over the evaporator pan and defrost water in the pan may overflow.

⚠ WARNING

- » Refrigeration lines are under pressure. Refrigerant must be recovered before attempting any connection or repair.

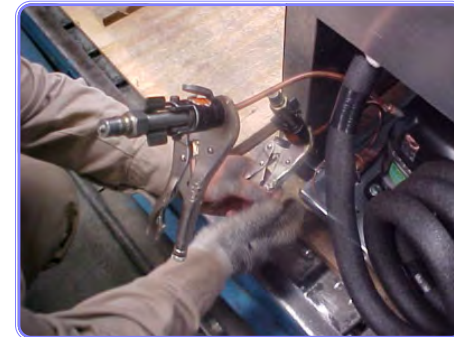

CONTROLLER

CONTROLLER OPERATION

The electronic controller is located in the cassette compartment. The controller comes factory set, and is ready for use. The front grille must be removed in order to access this control. When removing the grille for this operation or for condenser cleaning, care must be taken not to damage the display interface cable. It may be unplugged during this task.

1. Before inserting the power cord into a dedicated receptacle, complete the start-up sheet on Page 1-9. Turn the power switch to the "off" position. The power switch is located just below the controller. Next, plug in the power cord and turn the power switch "on". There is a 1-minute power-up delay.
 - a) The controller will illuminate
 - b) Interior lighting will illuminate
 - c) Evaporator fans will start

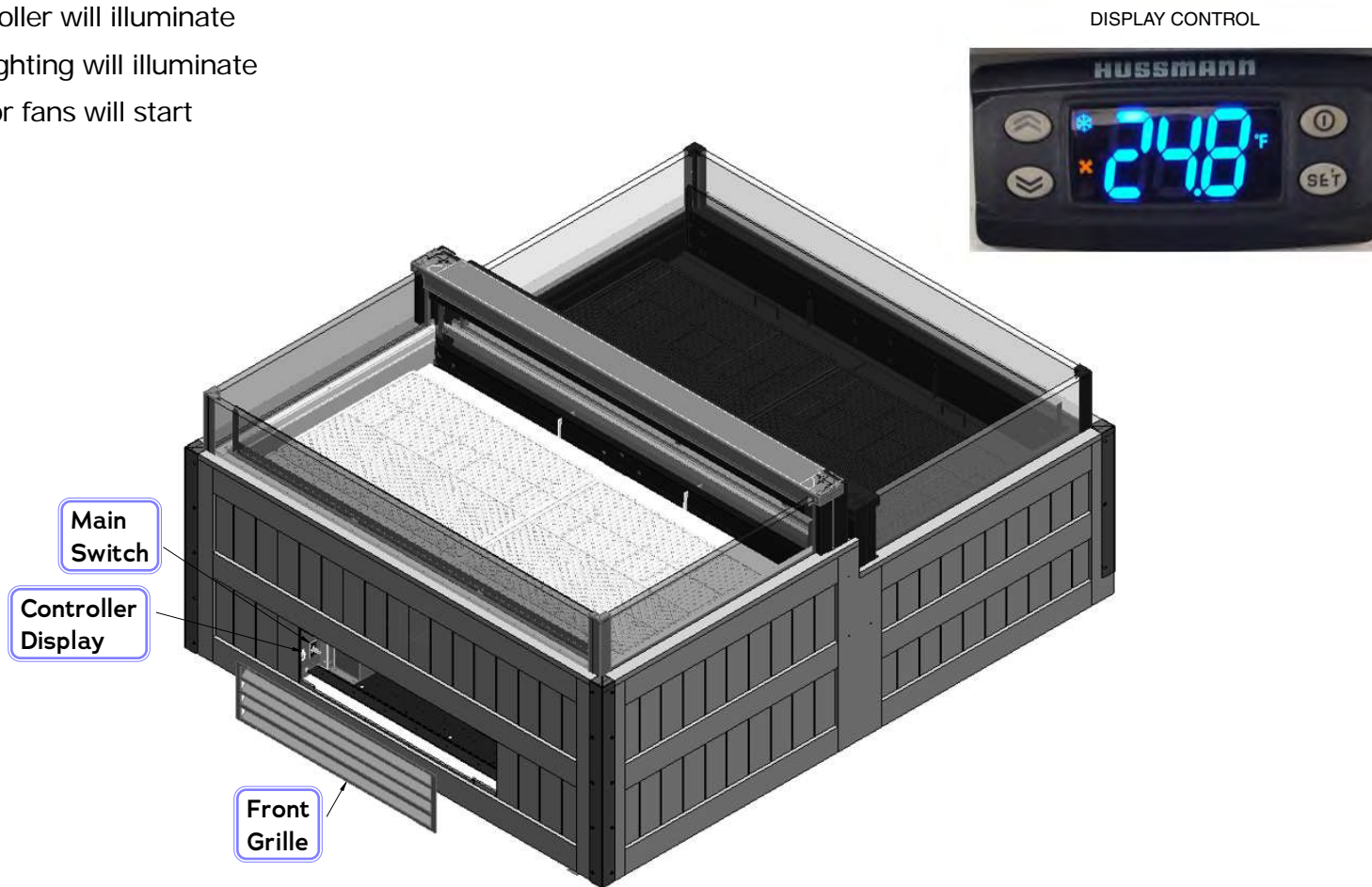

KEY FUNCTIONS:

- Evaporator fans and condenser fans
- Frame Heater
- LINK2 local area network
- RS485 communication protocol: Modbus
- Compatible with Device Manager (DM)
- Compatible with Unicard and Multi-function key

TECHNICAL DATA

Classification:	electronic automatic control (not safety) device for incorporation
Mounting:	panel mounting
Type of action:	1.B
Pollution class:	2
Material class:	IIIa
Overvoltage category:	II
Nominal pulse voltage:	2500V
Temperature:	Use: -5 ... +55°C - Storage: -30 ... +85°C
Power supply:	SMPS 100-240Va ±10% 50/60 Hz
Power consumption:	5.5W max
Fire resistance category:	D
Software class:	A
RTC battery life:	In absence of external power, the clock battery will last 3 years.

FURTHER INFORMATION

INPUT CHARACTERISTICS

Measurement range:	NTC: -50.0°C ... +110°C; (on 3-digit display with +/- sign) ±1.0° for temperatures below -30°C
Accuracy:	±0.5° for temperatures between -30°C and +25°C ±1.0° for temperatures above +25°C
Resolution:	1 or 0.1°C
Buzzer:	NO

TERMINALS

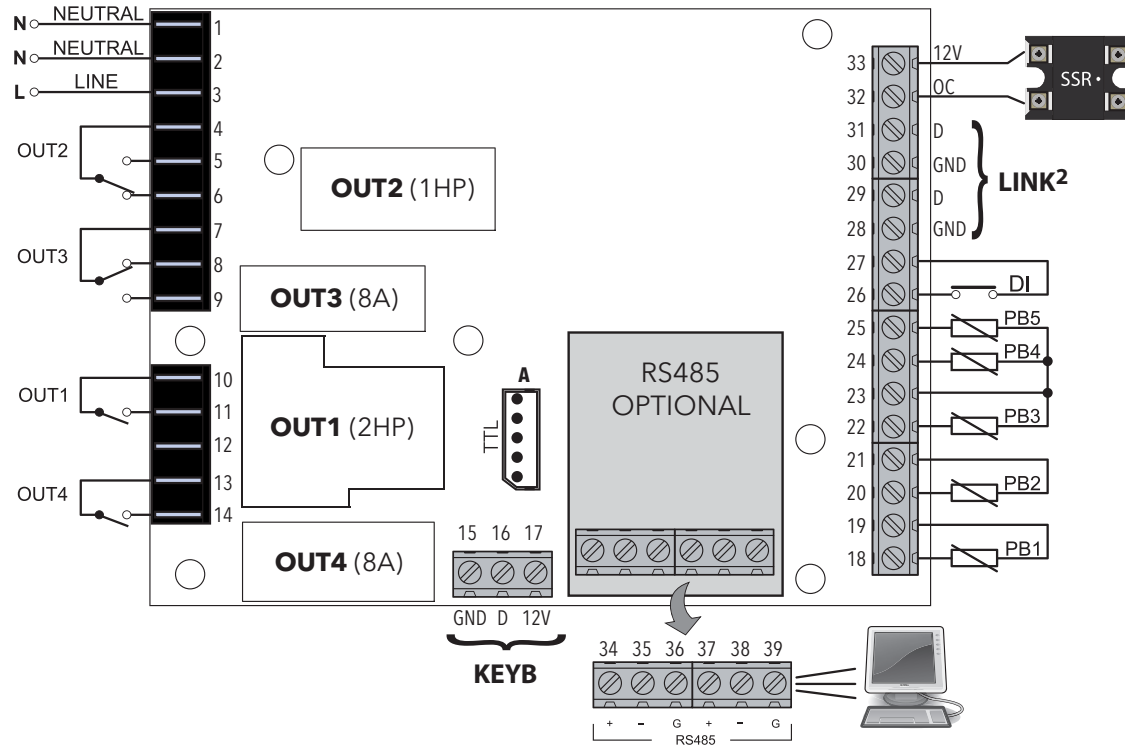

* **N.B.:** analogue inputs PB1...PB5 can also be configured as Digital Inputs DI.

TERMINALS	
1-2	NEUTRAL. These are power supply terminals.
3	LINE. These are power supply terminals.
4	OUT2 Shared Terminal
5	N.O. OUT2
6	N.C. OUT2
7	OUT3 Shared Terminal
8	N.C. OUT3
9	N.O. OUT3
10	OUT1 Shared Terminal
11	N.O. OUT1
12	Not Used
13	OUT4 Shared Terminal
14	N.O. OUT4
15-16-17	Connection to KDEPlus or KDWPlus external keyboard or ECPlus echo module.
19-18	PB1 probe connection.
21-20	PB2 probe connection.
23-22	PB3 probe connection.
23-24	PB4 probe connection.
23-25	PB5 probe connection.
27-26	Digital input (DI).
28-29	LINK ² . Connection 1 - local area network.
30-31	LINK ² . Connection 2 - local area network.
32-33	Open Collector Output (OC).
A	TTL Unicard/DMI/Multi Function Key connection
34-35-36	RS485. Connection 1 - Supervision Gateway.
37-38-39	RS485. Connection 2 - Supervision Gateway.

LED INDICATIONS

RTN400 family controllers will also function even if a keyboard has not been connected.
 With **KDEPlus** or **KDWPlus** keyboards (which are the same and guarantee the same functions), the display will be as follows:

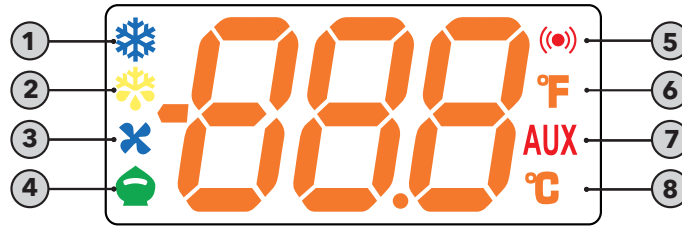

Meaning of LEDs:

No	Icon	LED	Operation	Meaning
1		Compressor	Permanently on	compressor on
			Blinking	Delay, protection or start-up blocked
			OFF	otherwise
2		Defrost	Permanently on	Defrost active
			Blinking	Activated manually or from Digital Input
			OFF	otherwise
3		Fans	Permanently on	Fans active
			OFF	otherwise
4		Reduced SET / Economy	Permanently on	Energy Saving active
			Blinking	Reduced setpoint active
			OFF	otherwise
5		Alarm	Permanently on	alarm active
			Blinking	Alarm acknowledged
			OFF	otherwise
6		°F readout	Permanently on	°F setting (dro = 1)
			OFF	otherwise
7	AUX	AUX	Permanently on	Aux output active and/or light on
			Blinking	Deep cooling on
			OFF	otherwise
8		°C readout	Permanently on	°C setting (dro = 0)
			OFF	otherwise

N.B.: When the instrument is powered on it performs a lamp test, during which time the display and LEDs will flash for several seconds to check that they all function correctly.

KDEPLUS BUTTONS

The **KDEPlus** keyboard has 4 keys, as shown in the illustration:

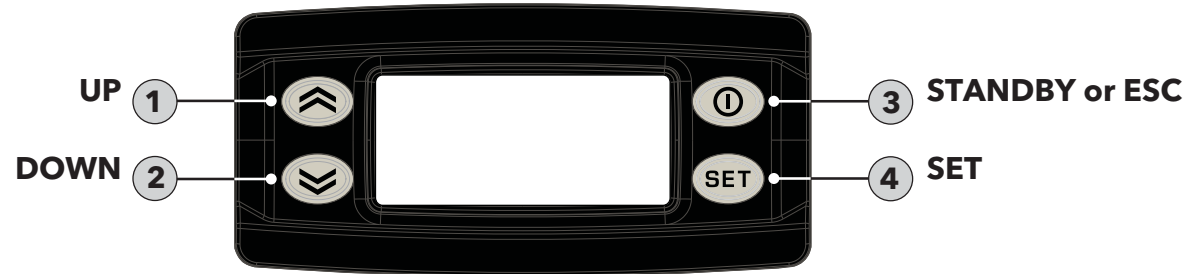





Each key has a different function depending on whether it is:

- Pressed and released
- Pressed for at least 5 seconds
- Pressed and held at start-up
- Pressed in combination with another key.

KEYS

The following table summarizes the function of each key:

No	Key	Action		
		Pressed and released	Press for at least 5 secs	Start-up
1		<ul style="list-style-type: none"> • Scrolls through menu items • Decreases values 	Activates the Manual Defrost function (from outside menus).	---
2		<ul style="list-style-type: none"> • Scrolls through menu items • Decreases values 	Function can be configured by the user (from outside menus). (see parameter H32)	---
3		<ul style="list-style-type: none"> • Returns to the previous menu level • Confirms parameter value 	Activates the Stand-by function (from outside menus).	---
4		<ul style="list-style-type: none"> • Displays any alarms (if active) • Opens Machine Status menu • Confirms commands 	Opens the Programming Menu (User and Installer parameters)	When pressed during start-up it enables the user to select the application to be loaded.

SET POINTS

SETPOINT: SETTING AND EDIT LOCK

To display the Setpoint value, press the **set** key to enter the “Machine Status” menu, then press the **set** key again when the “SEt” label is displayed.

The Setpoint value appears on the display. To change the Setpoint value, press the **UP** and **DOWN** keys within 15 seconds. Press **set** to confirm the modification.

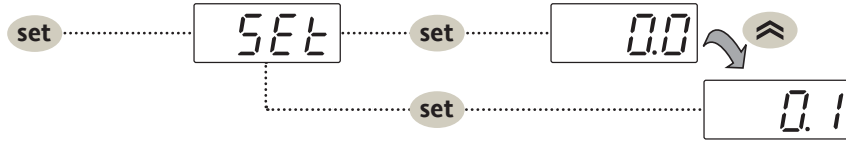

It is possible to disable the keypad on this device.

The keypad can be locked by programming the “LOC” parameter appropriately.

With the keypad locked, you can still access the “Machine Status” menu by pressing **set** to display the Setpoint, but you cannot edit it. To disable the keypad lock, repeat the locking procedure.

DISPLAY PROBES VALUE

To display the value read by probes connected to the device, press the **set** key and enter the “Machine Status” menu, then press the key again when one of the probe-related labels “Pb1...Pb5” press the **set** key again. The value measured by the associated probe will appear on the display.

NOTE: The displayed value is read-only and cannot be modified.

KEY-ACTIVATED FUNCTIONS

All models have the **UP** key set to enable the “Manual Defrost” function.

The DOWN and ESC keys can also be set to activate any other function required by the user.

The parameters for configuring the two keys are:

- **H11** = DOWN key configuration
- **H33** = ESC key configuration

The values that can be set apply to both keys and the functions that can be activated are:

H32/H33 value	Function to enable
0	disabled
1	defrost
2	reduced set
3	Light
4	Energy saving
5	AUX
6	Stand-by
7	Deep cooling cycle
8	Start/end defrost

KDEPLUS BUTTONS

The **KDEPlus** keyboard has 4 keys, as shown in the illustration:



SENSOR LOCATION

NOTE:

Sensors position is the same in both, lower and upper cases.

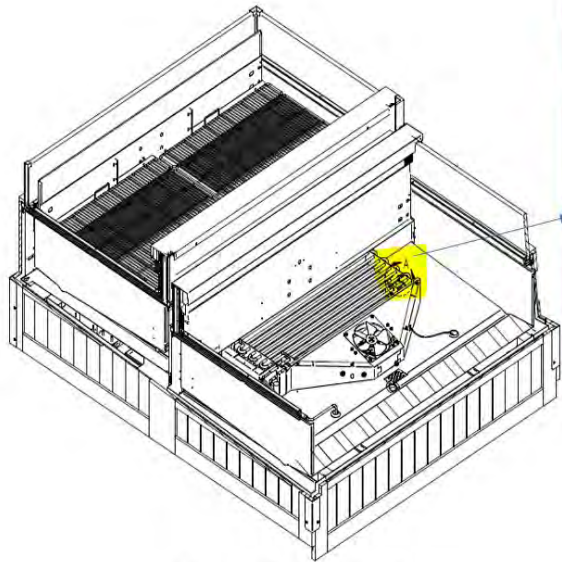

Defrost Sensor Location

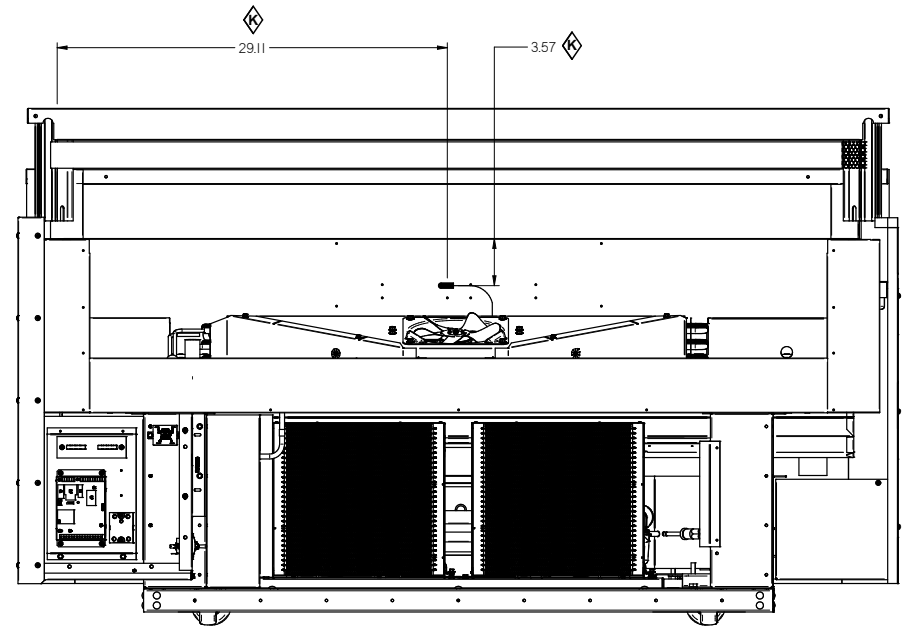

Discharge Sensor

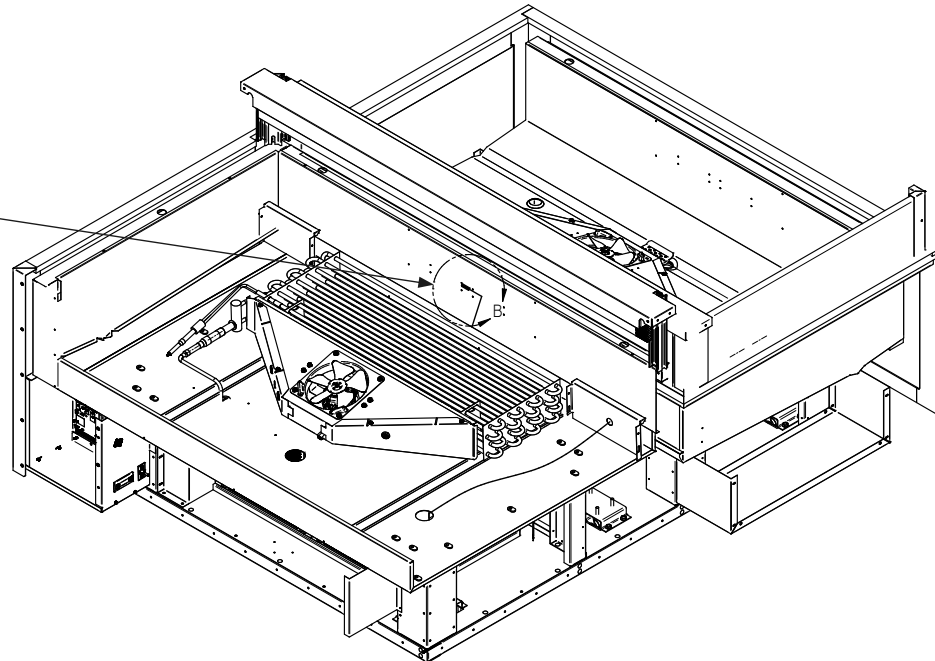

CONTROLS AND ADJUSTMENTS

Model	Product Application	Discharge Air Temperature (Avg Ref mode)	Controller Set Point (° F)	Tripping Differential (° F)
ISMGG2DAA	*Med Temp - Bulk Produce	22 - 24 ° F (-5 ° C to -4 ° C)	21 ° F (- 6 ° C)	12
	Med Temp - NSF 7 - Meat Deli	19 - 21 ° F (-7 ° C to -6 ° C)	18 ° F (- 7.7 ° C)	6

Model	Defrost Frequency (per day)	Type of Defrost	Temp. Termination	Failsafe time (min)
ISMGG2DAA	6	Off Time	44 ° F (6.6 ° C)	50

Note:

*The cases are shipped from the factory with controller settings to comply with Bulk Produce

The case is preprogrammed with a Tripping Differential of 12 °F. If NSF 7 application is required, adjust Tripping differential as shown in the Table above.

The Chart shown in the table above describes the operation of a ISMGG2DA-A model under ambient conditions of 75 °F and RH of 55%.

The controller controls refrigeration temperature. This is factory installed in the control panel. Adjust the control to maintain the discharge air temperature shown.

The factory defined set point is required for a typical application such as Produce. If for some reason, different temperatures are required for customer specific products, controller set point can be adjusted.

Defrosts are time initiated and temperature terminated. The defrost setting is factory set as shown above. To ensure a thorough defrost, defrost must be terminated by the temperature termination setting — not by time.

NOTE

Discharge air temperatures should be measured at the center of the discharge honeycomb.

INSTRUCTIONS TO CHANGE RTN CASE CONTROLLER SETTINGS

1. Menu tree:
 - a. The current discharge air is displayed. See picture below for controller key labels. (Fig. A)
 - b. Press and hold "set" for 5 s. HINT - If you press and hold for less than 5 seconds you will end up in a different menu set. Wait until the current air temp is displayed and retry, holding longer. Release the set key.
 - c. PA1 is displayed. Press up or down to get to PA2. Press "set" to accept PA2 (Fig. B next page).
 - d. Using the "up" key, press until 15 is displayed. This is the password that allows access to the full list of parameters. HINT - It will time out in 10 seconds or so and display the current air temp. If it does, repeat starting at Step b.

Current Air Display

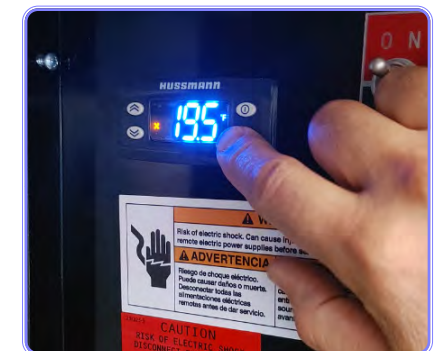

e. Scroll to:

f. CP (compressor) change the following parameters:

i. SP1 (regulation set point)

1. Meat/ deli set to 18° press set to accept.
2. Produce set to 21° press set to accept.

ii. dF1 (differential)

1. Meat/ deli set to 6° press set to accept.
2. Produce set to 12° press set to accept.

iii. Once complete, back out of CP menu by pressing button 3 the esc key.



PA2 to access parameter settings

Parameters to be changed from Bulk Product to Critical Temperature (NSF 7)

DESCRIPTION	UNITS	Factory Settings (Bulk Produce)	NSF 7
SP1 - Regulation set point	°F	21	18
dF1 - Tripping differential	°F	12	6

START UP / OPERATION

START UP

Follow the start up procedures as detailed in Section 3 of this manual. A thorough inspection should be made prior to start up to ensure there are no loose nuts, bolts, electrical connections or refrigeration lines rubbing or chaffing.

Turn the power switch to the ON position. Allow the system to reach normal operating temperature prior to loading any product. The merchandiser cabinet has a forced air curtain that flows over the top of the product. Air flows out of the honeycomb diffuser, across the product, and into the return air duct.

LOAD LIMITS

Each merchandiser has a load limit decal. Shelf life of perishables will be short if load limit is violated.



At no time should merchandisers be stocked beyond the load limits indicated.

Do not block honeycomb or return air grille.

STOCKING

Product should not be placed inside the merchandisers until merchandisers are at proper operating temperature.

Allow merchandiser 24 hours to operate before loading product.

⚠️ WARNING

- » Product will be degraded and may spoil if allowed to sit in a non-refrigerated area.

Proper rotation of product during stocking is necessary to prevent product loss. Always bring the oldest product to the front and set the newest to the back.

Air discharge and return flues must remain open and free of obstruction at all times to provide proper refrigeration and air curtain performance. Do not allow product, packages, signs, etc. to block these grilles. Do not use non-approved shelving, baskets, display racks, or any accessory that could hamper air curtain performance.

Do not allow product to be placed outside of the designated load limits in the illustration.

THERMOMETER

A solar powered thermometer is provided with each merchandiser. Temperature display in Fahrenheit degrees is standard. Celsius display is available as an option. The thermometer is located in the cabinet interior.

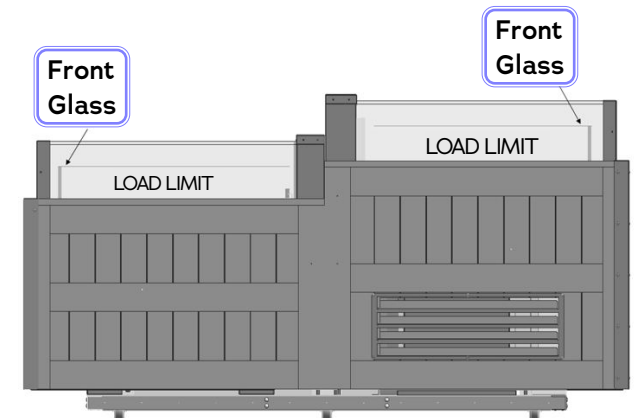

MAINTENANCE

⚠️ WARNING

- » To reduce the risk of fire, electrical shock or injury when cleaning this merchandiser:
- » Unplug the merchandiser before cleaning;
- » Keep all liquids away from electrical and electronic components;
- » Do not use any mechanical device or other means to speed the defrost process, except as recommended by the manufacturer.

CARE AND CLEANING

Long life and satisfactory performance of any equipment is dependent upon the care it receives. To ensure long life, proper sanitation and minimum maintenance costs, these merchandisers should be thoroughly cleaned, all debris removed and the interiors washed down, weekly.

Exterior Surfaces

The exterior surfaces must be cleaned with a mild detergent and warm water to protect and maintain their attractive finish. Never use abrasive cleansers or scouring pads.

Interior Surfaces

The interior surfaces may be cleaned with most domestic detergents, ammonia based cleaners and sanitizing solutions with no harm to the surface. Self contained models empty into a limited capacity evaporation pan, which will overflow if excess water is used in cleaning.

DO Not:

Abrasive cleansers and scouring pads, as these will mar the finish or coarse paper towels on coated glass. DO NOT use ammonia-based cleaners on acrylic parts.

Solvent, oil or acidic based cleaners on any interior surfaces. Do not use high pressure water hoses.

DO not flood merchandiser with water. Never introduce water faster than the waste outlet can remove it. Self contained models empty into an evaporation pan that will overflow if too much water is introduced during cleaning.

Do:

Remove the product and all loose debris to avoid clogging the waste outlet. Store product in a refrigerated area such as a cooler. Remove only as much product as can be taken to the cooler in a timely manner. Disconnect electrical power before cleaning.

Thoroughly clean all surfaces with soap and hot water. Do not use steam or high water pressure hoses to wash the interior. These will destroy the merchandisers' sealing causing leaks and poor performance.

Take care to minimize direct contact between fan motors and cleaning or rinse water.

Allow merchandisers to dry before resuming operation. After cleaning is completed, turn on power to the merchandiser.

⚠️ WARNING

- » Do NOT use HOT water on Cold glass Surfaces. This can cause the glass to shatter and could result in personal injury. Allow glass fronts, to warm before applying hot water.

CLEANING DISCHARGE HONEYCOMB

Discharge honeycombs should be cleaned every six months. Dirty honeycombs will cause merchandisers to perform poorly. The honeycombs may be cleaned with a vacuum cleaner.

Soap and water may be used if all water is removed from the honeycomb cells before replacing. Be careful not to damage the honeycomb.

1. Using a flat object such as a screw driver, compress the honeycomb and remove it from its retainer.
2. Clean and dry the honeycomb.
3. After cleaning, replace in reverse order.
Damaged honeycomb must be replaced.

CLEANING THERMOMETER

Remove the two screws holding the thermometer to its mounting bracket. Remove the sensing element from its clip. Clean the element with water and mild detergent solution. Ensure the sensing element is wiped clean of any residue to ensure proper temperature readings.

CLEANING COILS

Condenser coils should be cleaned at least once per month. Additional cleaning may be needed depending on the operational environment. A dirty condenser blocks normal airflow through the coils.



never use sharp objects around coils. Use a soft brush or vacuum brush to clean debris from coils. Do not puncture coils! Do not bend fins. Contact an authorized service technician if a coil is punctured, cracked, or otherwise damaged.

ICE in or on the coil indicates the refrigeration and defrost cycle is not operating properly. Contact an authorized service technician to determine the cause of icing, and to make adjustments as necessary. To maintain product integrity, move all product to a cooler until the unit has returned to normal operating temperatures.

Airflow blockage increases energy consumption and reduces the merchandiser's ability to maintain operating temperature.

To clean the coils, use a vacuum cleaner with a wand attachment and a soft (non-metallic) brush to remove dirt and debris. Do not bend coil fins. Always wear gloves and protective eye wear when cleaning near sharp coil fins and dust particles.

⚠ WARNING

- » Shut fans OFF during cleaning process.

CLEANING EVAPORATION PAN

The condensate water outlet for self contained models empties into a limited capacity evaporation pan.

Debris or dirt accumulation inside the condensate evaporation pan will reduce the pan's evaporation capacity and cause premature heater failure. The evaporation pan waste water will overflow and spill onto the floor if the heater is not properly operating.

Remove accumulated debris from the evaporation pan. Wipe down heater coil with a cloth and warm water. Be sure to remove any dirt, debris or liquids from the heater coil. Water introduced during cleaning will cause the evaporation pan to overflow.

REMOVING SCRATCHES FROM BUMPER

Most scratches and dings can be removed using the following procedure.

1. Use steel wool to smooth out the surface area of the bumper.
2. Clean area.
3. Apply vinyl or car wax and polish surface for a smooth glossy finish.

CAUTION

- » DO NOT FLOOD! Use only enough water necessary to clean surface. Water must not drip down the case!
- » Never use ammonia based cleansers, abrasive cleansers, or scouring pads.



PRECAUTION CLEANING PRECAUTIONS

When Cleaning:

- Do not use high pressure water hoses
- Do not introduce water faster than waste outlet can drain
- NEVER INTRODUCE WATER ON SELF CONTAINED UNIT WITH AN EVAPORATION PAN
- NEVER USE A CLEANING OR SANITIZING SOLUTION THAT HAS OIL BASE (these will dissolve the butyl sealants) or an AMMONIA BASE (this will corrode the copper components of the merchandiser)
- TO PRESERVE THE ATTRACTIVE FINISH:
 - Use a water and a mild detergent for the exterior only
 - Do NOT use a chlorinated cleaner on any surface
 - Do NOT use abrasives or steel wool scouring pads (these will mar the finish)

SELF-CONTAINED REFRIGERATION EQUIPMENT MAINTENANCE CHECK LIST

***** Warranty does not cover issues caused by improper installation or lack of basic preventative maintenance. *****										
Record starting date										
Store Name and Number										
Store Address										
Unit Model Number										
Unit Serial Number										
Contractor/Technician										
	Technician									
	PM date									
PM activity - For visual inspection items, denote "ok or complete" in the column to the right when PM has been performed. For measured data requested, record data requested in the appropriate column to the right	Quarterly	Semi-Annually	Q1	Q2	Q3	Q4	Q1	Q2	Q3	Q4
Check in with store manager, record any complaints or issues they have with unit.	X									
Look unit over for any damage, vibrations or abnormal noise.	X									
Verify unit is level side to side and front to rear.	X									
Confirm refrigerant lines properly are secured and not touching or rubbing other lines, wires or frame work.	X									
Verify fan motors and motor mounts are tight.	X									
Confirm fan blade/s are tight and not rubbing or hitting.	X									
Make sure all electrical connections, factory and field, are tight.	X									
Verify electrical connections at lamps are they secure and dry.	X									
Check for and replace any frayed or chaffed wiring.	X									
Check all electrical wiring make sure it is secured and not on any sharp edges or hot lines.	X									
Check for air disturbances external to the unit. Heat and air registers, fans, and doors etc.	X									
Check for water leaks.	X									
Clean evaporator coil/s and fan blade/s. Do not use an acid base cleaner. Rinse off any cleaner residue.		X								
Clean discharge air honeycombs or grilles. Do not use an acid base cleaner. Rinse off any cleaner residue.		X								
Clean condenser coil/s and fan blade/s. Do not use an acid base Cleaner. Rinse off any cleaner residue.		X								
Clean condensate drain pan and drain line.		X								
Verify condensate drain lines are clear and functioning.		X								
Record voltage reading at unit with unit off?		X								
Verify condenser and evaporator fans are working.	X									
Record condenser air inlet temperature	X									
Record condenser air outlet temperature	X									
Is condenser air inlet or air exhaust restricted or recirculating?	X									
Verify there are no visual oil or refrigerant leaks.	X									
Record voltage reading with unit running.		X								
Record compressor amp draw.		X								
Record defrost heater voltage and amp draw.		X								
Record anti-sweat heater voltage and amp draw.		X								
Record case product temperature.	X									
Record unit discharge air temperature.	X									
Record unit return air temperature.	X									
Record ambient conditions around unit (wet Bulb temperature and dry bulb temperature).	X									
Check product loading, do not load beyond the units load limits.	X									
Verify clearances on sides/back of unit.	X									
Check unit controller for proper operation. See controller or 1/0 Manual for proper controller operation.		X								
Confirm door switches function.	X									
Verify unit doors and lids work and are sealed correctly.	X									
Verify that all the panels, shields and covers are in place.	X									

SERVICE

Replacing Condenser Fan Motors and Blades

Should it ever be necessary to service or replace the fan motors or blades be certain that the fan blades are reinstalled correctly. The blades must be installed with raised embossing (part number on plastic blades) positioned as indicated on the parts list.

For access to these fans:

1. Remove product and place in a refrigerated area. Turn off power to the merchandiser.
2. Make sure there is no voltage in the refrigerator. Remove front grille to have access to the machine compartment.
3. Disconnect condenser motor harness.
4. Remove screws and remove condenser fan assembly (Fig. C).
5. Use a 5/16-inch nut driver or cordless drill to remove motor screws and pull out motor / blade assembly (Fig. D).
6. Change the failed part.
7. If the only damaged part is the motor, remove blade.
8. Reverse the process, and make sure everything is in place.

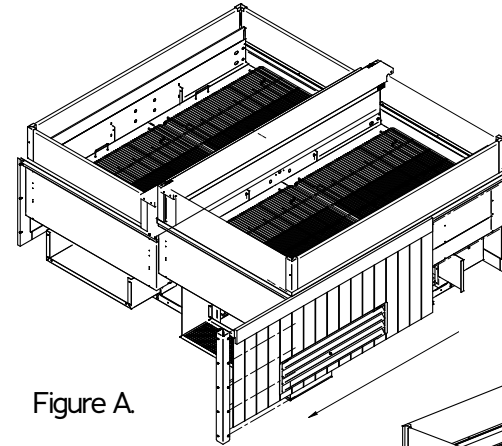

Pull Wood Front Panel to the Left

Figure A.

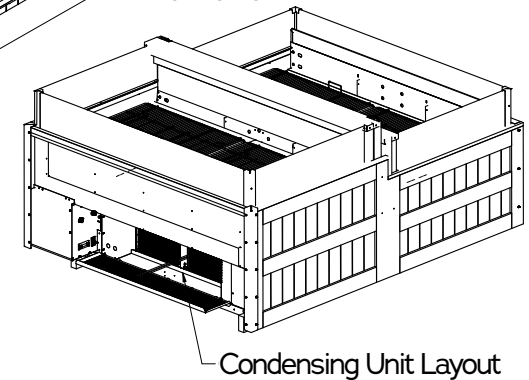

Condensing Unit Layout

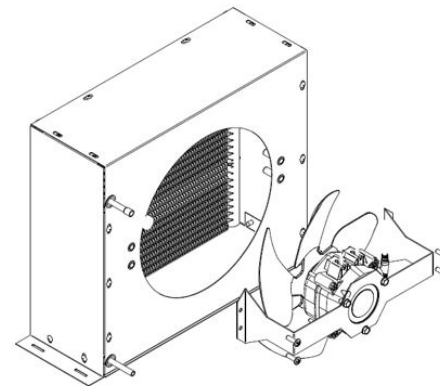

Figure C . Condenser fan bracket screws

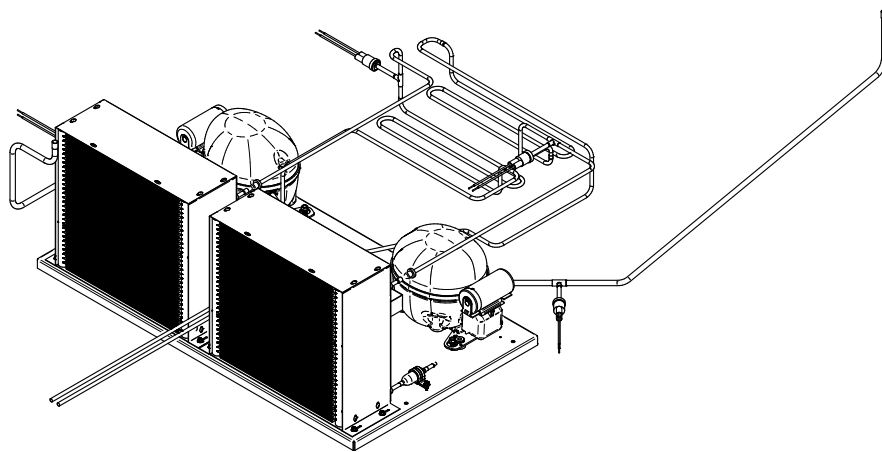

Figure B. Condensing Unit Layout

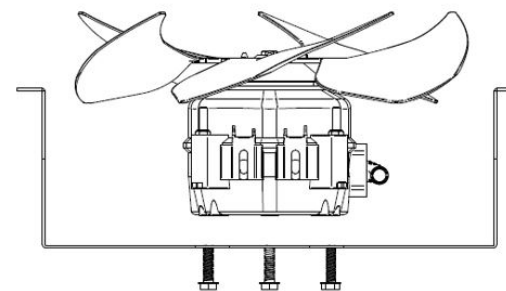

Figure D . Condenser fan motor screws

REPLACING FAN MOTORS AND BLADES

Should it ever be necessary to service or replace the fan motors or blades be certain that the fan blades are reinstalled correctly. The blades must be installed with raised embossing (part number on plastic blades) positioned as indicated on the parts list.

For access to these fans:

1. Remove product and place in a refrigerated area. Turn off power to the merchandiser.
2. Remove bottom display pans.
3. Disconnect fan from wiring harness.
4. Remove fan blade.
5. Lift fan plenum and remove screws holding bottom of motor to fan basket.
6. Replace fan motor and blade.
7. Lower fan plenum.
8. Reconnect fan to wiring harness.
9. Turn on power.
10. Verify that motor is working and blade is turning in the correct direction.
11. Close air gaps under fan plenum. Warmer air moving into refrigerated air reduces effective cooling. If the plenum does not rest against the case bottom without gaps, apply foam tape to the bottom of the fan plenum to reduce improper air movement. Use silicone sealant to close other gaps.
12. Reinstall display pans. Bring merchandiser to operating temperature before restocking.

⚠ WARNING

Product will be degraded and may spoil if allowed to sit in a non-refrigerated area. Do NOT allow cleaning agent or cloth to contact food product.

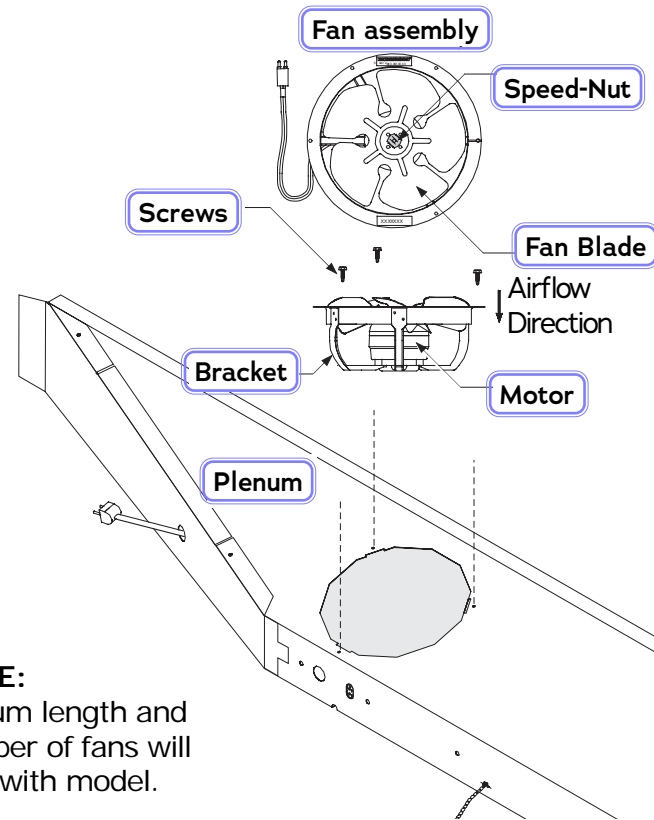

NOTE:
Plenum length and number of fans will vary with model.

⚠ WARNING

— LOCK OUT / TAG OUT —

- » To avoid serious injury or death from electrical shock, always disconnect the electrical power at the main disconnect when servicing or replacing any electrical component. This includes, but is not limited to, such items as doors, lights, fans, heaters, and thermostats.

TROUBLESHOOTING

Problem	Possible Cause	Possible Solution
Case temperature is too warm.	Ambient conditions may be affecting the case operation.	Check case position in store. Is the case located near an open door, window, electric fan or air conditioning vent that may cause air currents? Case must be located minimum 15 Ft away from doors or windows. Cases are designed to operate at 55% Relative humidity and a temperature of 75-80°F.
	Discharge air temp is out of spec.	Check evaporator fan operation. Check electrical connections and input voltage.
		Fans are installed backwards. Check airflow direction.
		Fan blades are installed incorrectly. Make sure fan blades have correct pitch and are per specification.
		Check to see that fan plenum is installed correctly. It should not have any gaps.
		Check suction pressure and ensure that it meets factory specifications.
	Case is in defrost.	Check defrost settings. See Technical Specifications section.
	Product is outside of the load limit area, blocking airflow.	Redistribute product so it does not exceed load limit. There is a sticker on the inside of the case indicating what the maximum load line is. See page 15 for details.
Coil is freezing over. Condensing coil or evaporator coil is clogged or dirty.	Return air is blocked, make sure debris is not blocking the intake section.	
	Coil close-offs are not installed. Inspect coil to make sure these parts are on the case.	
	Clean coil.	
Case temperature is too cold.	The t-stat temp is set too low.	Check settings. See Technical Specifications section.
	Ambient conditions may be affecting the case operation.	Check case position in store. Is the case located near an open door, window, electric fan or air conditioning vent that may cause air currents? Case must be located minimum 15 Ft away from doors or windows. Cases are designed to operate at 55% Relative humidity and a temperature of 75-80°F.

Troubleshooting (Continued)

Problem	Possible Cause	Possible Solution
Condensation on plex / glass.	Ambient conditions may be affecting the case operation.	Check case position in store. Is the case located near an open door, window, electric fan or air conditioning vent that may cause air currents? Case must be located minimum 15 Ft away from doors or windows. Cases are designed to operate at 55% Relative humidity and a temperature of 75-80°F.
	Inadequate air circulation.	Check if air sweep fans are functioning, check electrical connections.
	There is not enough heat provided in the airflow.	Check if air sweep heater is functioning, check electrical connections.
	There are glass gaps on the side of the case.	See glass adjustment section.
	Glass is not completely shut.	Close glass correctly.
Water has pooled under case.	Case drain is clogged.	Clear drain.
	PVC drains under case may have a leak.	Repair as needed.
	Case tub has unsealed opening.	Seal as needed.
	If the case is in a line- up, case to case joint is missing or unsealed.	Install case to case joint and seal as needed.
	Evaporator pan is overflowing (if applicable).	Check electrical connection to evaporator pan. Check float assembly, it should move freely up and down the support stem. Clear any debris.
Case is not draining properly.	Case is not level.	Level the case.
	Drain screen is plugged.	Clean drain screen and remove any debris.
	Drain or P-trap is clogged.	Clear any debris.
Frost or ice on evaporator coil.	Evaporator fans are not functioning.	Check electrical connections.
	Defrost clock is not functioning.	Case should be serviced by a qualified service technician.
	Coil is freezing over.	Return air is blocked, make sure debris is not blocking the intake section.
		Coil close-offs are not installed. Inspect coil to make sure these parts are on the case.

WARRANTY INFORMATION

HUSSMANN®

To obtain warranty information or other support, contact your Hussmann representative or visit: <https://www.hussmann.com/services/warranty>.
Please include the model and serial number of the product.

For questions about your equipment please contact our Technical Support Team 866-785-8499

For General Support or Service Calls contact our Customer Support Call Center 800-922-1919

For ordering Aftermarket Warranty Parts 1-855-Huss-Prt (1-855-487-7778) Hussmann_part_warranty@hussmann.com