

CLS

Coupé and Shooting Brake



Mercedes-Benz



Fascination CLS. Design, illuminated.

How many times does one meet an exceptional personality in one's lifetime? If you wish, it can be every day – and on every drive. The CLS captivates with its pioneering LED light system, its efficient, powerful engines, an innovation in its transmission design and lots, lots more. All showcased by highly distinctive design. Discover the perfect symbiosis of light and form.

ILLUMINATING SOURCES.



Experience the CLS in exciting HD. With the Mercedes-Benz brochure app for the iPad® and with the Digital Owner's Manual from "Mercedes-Benz Guides" for the iPhone®. Both apps feature a host of films and additional content and are available free of charge from the iTunes Store®.

Illuminating spectrum.

2 | CLS 500 Coupé diamond silver metallic

AMG Line, AMG multi-spoke light-alloy wheels, designo semi-aniline leather upholstery in classic red/black, black piano lacquer trim

10 | Mercedes-AMG CLS 63 S 4MATIC Coupé designo diamond white bright

AMG Exterior Carbon-Fibre package I + II, AMG cross-spoke forged wheels, Exclusive package, Exclusive PASSION leather upholstery in black with light contrasting topstitching, AMG carbon-fibre/black piano lacquer trim

16 | CLS 350 d Shooting Brake cavansite blue metallic

Exterior Sports package, 5-twin-spoke light-alloy wheels, Exclusive package, Exclusive PASSION leather upholstery in saddle brown/black, high-gloss brown linestructure lime wood trim

24 | Mercedes-AMG CLS 63 S 4MATIC Shooting Brake selenite grey metallic

AMG Night package, AMG 10-spoke light-alloy wheels, Exclusive package, Exclusive PASSION leather upholstery in black with light contrasting topstitching, black AMG carbon-fibre/piano lacquer trim

Illuminating strengths.

- 30** | Mercedes me
- 34** | Services
- 38** | Engines
- 40** | 9G-TRONIC automatic transmission
- 41** | AIRMATIC air suspension system
- 42** | MULTIBEAM LED light system
- 44** | Driving Assistance package Plus
- 47** | Integral safety concept
- 48** | Mercedes connect me
- 52** | Mercedes-AMG CLS 63
- 54** | AMG Night package
- 55** | AMG Exterior Carbon-Fibre package
- 56** | Mercedes-AMG CLS 63 S 4MATIC
- 59** | AMG Performance Studio
- 60** | Equipment and packages
- 66** | designo
- 67** | Genuine Accessories
- 68** | Wheels
- 70** | Technical data
- 73** | Upholstery and paintwork

The illustrations may show accessories and optional extras which are not part of the standard specification.



Coupés have always had that certain special something about them. But the Mercedes-Benz engineers wanted even more: a Coupé with four doors and comfortable rear seats. The launch of the CLS marked the birth of a design icon that can only be surpassed by its own self. With the nine-speed 9G-TRONIC automatic transmission for even more efficiency and dynamism (for selected models). The optionally available MULTIBEAM LED light system. And lines that are just made for a grand entrance.

Outshines everything.





MULTIBEAM LED

LEDs are very much at the forefront when it comes to the future of lighting technology – due to their stronger luminosity and the rare semiconductor crystals. With their help, the luminous efficiency of LEDs can exceed that of conventional bulbs several times over. If the optionally available MULTIBEAM LED light system is ordered, each headlamp is equipped with 36 LEDs, of which 24 can actually be

controlled individually. To this end, a camera positioned behind the windscreen surveys the current traffic conditions. Based on the information they receive, four control units calculate the ideal light pattern a hundred times per second and direct the LEDs almost instantaneously to shine where their light is needed.

Shedding a whole
new light.





A brilliant spectacle.







At the airport you are ushered into the business lounge. On the train you can prepare for your next meeting whilst travelling at high speed. But the most pleasurable trips of all are at the wheel of the CLS Coupé. The extensive range of standard equipment and appointments, including a 20.3 cm display, the choice materials and a wealth of individualisation options such as the designo interior colour schemes, create special surroundings for special moments.



Puts the rest of the world in the shade in 3.6 seconds.

When the Mercedes-AMG CLS 63 S 4MATIC Coupé rated at 430 kW (585 hp) and 800 Nm is straining at the leash, there's no holding back your endorphins. The dynamically configured AMG Performance 4MATIC all-wheel drive ensures that the road also gets to feel the concentrated power of the AMG 5.5-litre V8 biturbo engine. This means that other drivers sadly only catch a fleeting glimpse of the AMG front apron in striking A-wing design and the rear end dominated by the diffuser and featuring two chromed twin tailpipe trim elements.







Illuminating speed.

More comet than coupé.





Who wouldn't want to be cosseted by these seats? Refined with light contrasting stitching in conjunction with optionally available black Exclusive PASSION leather and crowned by "AMG" emblems in the front head restraints, they provide perfect support on fast bends. Step over the white illuminated AMG door sill panels – and experience the sheer excitement of AMG the moment you first set eyes on the AMG instrument cluster, including a 11.4 cm TFT multifunction display, RACETIMER and AMG start-up display.

A unique allure.

Certain personalities exude a special aura. It's hard to describe, but you feel it straight away. They are, quite literally, a phenomenon – just like the CLS Shooting Brake. A heady mix of delightful comfort and thrilling dynamism. Highly impressive in stature. And with a design idiom that gets everyone talking.





The calm and the storm:
the 9G-TRONIC.





9G-TRONIC

When Carl Benz invented the automobile, he used a flat belt to transfer the engine power. For starting off, this belt was moved from an idler pulley onto a fixed pulley. This design gave the original version of the patent motor car precisely one gear – and laid the foundations for every Mercedes-Benz transmission innovation since. Such as the 9G-TRONIC nine-speed automatic transmission (avail-

ability dependent on engine), which performs highly complex gear changes using just four simple planetary gear groups and six shift components – allowing an extremely compact design. Lower rpm levels mean that the 9G-TRONIC also reduces fuel consumption. All that increases is the driving enjoyment – thanks to faster gear changes with smaller engine speed increments.

Freedom to do more.

Do you like expanding your horizons? You don't have to look too far to keep on discovering new things in the CLS Shooting Brake. Although it wouldn't be difficult, in this spaciouly designed interior. A third seat in the rear allows up to five people to enjoy the view – not least of the high-grade interior appointments in the optionally available saddle brown/black colour combination.





A close-up photograph of a car seat upholstered in brown perforated leather. The seat features a ribbed design on the backrest and a perforated texture on the seat cushion. The lighting is warm, highlighting the texture of the leather. In the background, another similar seat and the interior of the car are visible.

You could soon be the one sitting in the ergonomically designed seats of the CLS. They even come with the option of exclusive semi-aniline leather upholstery. Look forward to outstanding workmanship – and optional climatized seats. The optional high-gloss brown linestructure lime wood trim underscores this unique ambience throughout the interior.



Even the earth feels attracted to it.

The Mercedes-AMG CLS 63 S 4MATIC Shooting Brake would have turned the world of Isaac Newton well and truly on its head, as its gravitational attraction knows almost no bounds. The dynamically configured AMG Performance 4MATIC all-wheel drive with a rear-biased torque split of 33:67 combines optimum traction, hallmark AMG driving dynamics and maximum driving enjoyment. Depending on the selected ESP® stage, individual brake actuations on each wheel and active engine management reduce understeer. This results in maximum driving stability and lateral dynamics.









AMG. High performance
inside and out.



Inner force.

The cockpit of the Mercedes-AMG CLS 63 S 4MATIC Shooting Brake is a blend of systematic functionality and exclusive appointments. Finely matched with optionally available AMG carbon-fibre/black piano lacquer trim. With an AMG performance steering wheel, including “AMG” lettering and alpaca grey 12 o’clock marking, plus an instrument cluster with a speed scale that now goes all the way up to 320 km/h.

DESIGNO WOODEN LOAD COMPARTMENT FLOOR

A material usually reserved for the sun decks of large yachts is available as an option to add a further touch of refinement to the load compartment in the CLS Shooting Brake: American cherry wood with black inlay work in dark fumed oak. Using a sophisticated production process, carefully selected veneer sheets are glued and pressed together by hand under high pressure in five layers to achieve high dimensional stability. Finally, the surfaces are painstakingly sanded to a smooth finish and waterproofed before being varnished. All of which emphasises the natural beauty of the robust fine wood.



Our next great innovation revolves around you.

Prepare to be inspired, surprised and thrilled by new services, products and experiences at www.mercedes.me. You are also warmly invited to check out our Mercedes me stores in major cities such as Hamburg, Milan, Tokyo or Hong Kong.





Mercedes me. Welcome to your Mercedes-Benz world.

You have new questions, Mercedes-Benz has a new answer for you: Mercedes me. Your point of access to a fascinating world of personalised services from Mercedes-Benz. Offering innovative, individualised mobility, connectivity, finance and other services, as well as special brand experiences. All subject to continual development. Innovative, simple and cutting-edge: www.mercedes.me

Join us – on your smartphone, tablet or PC. And let's shape tomorrow's world together. Any time, anywhere.

Mercedes connect me is all about networking the vehicle with the driver – and more besides: the car is becoming part of the way we live, providing added comfort as well as the reassurance of being permanently connected, even while on the move. Mercedes connect me includes Standard Services, which are able to provide you with automatic support in the event of a breakdown or an accident, and Remote Online Services – the option enabling vehicle settings to be carried out by smartphone.



Mercedes finance me offers you various routes to your vehicle of choice. Mercedes-Benz Financial Services finds the ideal leasing, financing and insurance solution together with you – tailored to your needs. Our leasing products enable you to drive the latest models at all times while enjoying maximum flexibility, as you pay not for acquisition of the vehicle, but only for its use. You also benefit from attractive monthly instalments. Our financing arrangements enable you to pay for your new Mercedes-Benz in a way that suits your personal budget. You can tailor your monthly instalments to your needs by deciding on an appropriate down-payment and term for your contract. Our individual insurance solutions offer reliable protection for your budget and your vehicle on attractive terms.

Mercedes inspire me offers special brand experiences and an opportunity to engage in an inspiring dialogue. We aim to share our ideas with you and we would like to know your ideas and wishes. So that we can always offer you the best solutions. A community is available to this end, and you will also find a growing range of offerings and experiences which go beyond the traditional vehicle-related topics – from areas such as events, travel and lifestyle.

Mercedes move me offers access to the intelligent mobility solution moovel: this mobility app pools the offerings from various mobility providers to find the ideal route from A to B. car2go is the pioneer and market leader worldwide in free-floating car sharing, and car2go black stands for smartphone-based car sharing with Mercedes-Benz B-Class vehicles. With the mytaxi app you can order a taxi, track its approach live and pay for your journey in a convenient manner.

Mercedes assist me makes easy work of organising maintenance for your vehicle, providing a convenient online means of locating a Mercedes-Benz dealer in your neighbourhood and arranging a service appointment. The digital service report keeps you up to date on performed service work at all times. The report is available to you online just one day after a service. In addition to the current service report, you can also view your vehicle's complete service history and service intervals, and you can print this information out if you so wish.

**Mercedes-Benz
Service**



Our service: the perfect fit for your Mercedes.

Beyond the car itself, you also acquire something priceless – an exclusive partnership with Mercedes-Benz. For you, this means safety, independence and motoring free of any worries. In other words: the reassuring feeling of driving a Mercedes.

The best for your Mercedes. No-one knows your Mercedes better than our experienced specialists at the Mercedes-Benz workshops. The comprehensive range of services and the high standard of quality ensure that your vehicle is in top condition. We use tested Mercedes-Benz GenuineParts and special tools to this end.

The best for you. Motoring free of any worries right from the word go: with the tailor-made Mercedes-Benz Service Contracts. These offer you the benefits of a reliable basis for long-term planning, permanent control over costs, fixed monthly rates and cost transparency. Plus ideal protection from additional workshop costs.

The best for your mobility. The Mercedes-Benz Mobilo¹ insurance package provides for motoring free of any worries throughout Europe – covering breakdowns, accidents, minor mishaps and vandalism. The benefits offered by Mobilo include on-the-spot assistance, a replacement vehicle, towing and overnight hotel accommodation, for example. This mobility guarantee is automatically on board for the first two years after initial registration, and can subsequently be renewed for a period of up to 30 years in all. Whenever you need assistance, you can reach us free of charge throughout Europe on 00800 1 777 7777².

↘ FIND OUT MORE

For the full information on Mercedes-Benz Service Contracts, go to www.mercedes-benz.com/servicevertraege – or ask your authorised Mercedes-Benz dealer to draw up an individual offer for you.

¹ Our general terms and conditions apply. The period of validity is extended after each service carried out by an authorised Mercedes-Benz service partner until the due date for the next service – up to a maximum of 30 years after initial registration. ² Roaming charges may apply when calling from abroad.

What would motorsport be without Mercedes-Benz?

The first vehicle ever to win an automobile race was powered by a Daimler engine. The first Mercedes was a racing car. The Silver Arrows – a true legend. Mercedes-Benz has a long tradition of involvement with the world of sport. Motorsport shapes the brand and every vehicle bearing the Mercedes star to this day. Discover the brand's unique history first-hand: at the Mercedes-Benz Museum in Stuttgart.

↘ FIND OUT MORE

Discover just what has been moving the world for almost 130 years and take a journey through time as well as through the history of the automobile at the Mercedes-Benz Museum. More than 1500 exhibits await you on 16,500 sqm of floor-space, including unique gems such as the oldest surviving Mercedes from 1902 or the legendary gull-wing models. Welcome to a place of innovation:

www.mercedes-benz.com/museum



What would Mercedes-Benz be without motorsport?

3 June 1934 marked the beginning of the Silver Arrows legend in the International Eifel Race at the Nürburgring. The Silver Arrows works team MERCEDES AMG PETRONAS continued this tradition in the 2014 Formula 1 season. Its successful involvement was crowned by the most impressive double victory of the season, with the team topping both the constructors' and the drivers' rankings. The team's successes are not restricted to the race track, however. Every mile raced also advances the development of hybrid technology for series production.

FIND OUT MORE

Fascinating Formula 1 goes multimedia:

<http://www.facebook.com/MercedesAMGF1>

<http://twitter.com/MERCEDESAMGF1>

<http://www.youtube.com/user/MERCEDESAMGPETRONAS>

<http://plus.google.com/+Mercedesamgf1/posts>

<http://instagram.com/MercedesAMGF1#>

<http://www.MercedesAMGF1.com>



MERCEDES AMG PETRONAS F1 W06 hybrid, 2015 season.

Hungry rather than thirsty: the drive technologies.

Efficiency and dynamism have long gone hand in hand at Mercedes-Benz. The **CLS 400** with V6 petrol engine, twin turbochargers and a displacement of 3.5 litres succeeds in combining low fuel consumption with a further substantial increase in output. In particular, the engine speed range across which the maximum torque is available ensures high-level driving dynamics at relatively low revs.

Clean power: clean combustion.

Our diesel engines are also more efficient than ever, thanks to the Mercedes-Benz-developed modular concept for effective reduction of fuel consumption and emissions. The CLS diesel models – all models with the “d” model designation – feature an oxidation catalytic converter and a particulate filter. These are combined with an additional SCR catalytic converter (SCR = Selective Catalytic Reduction). The increase in peak pressure and compression

ratio leads to improved combustion and a lower particulate mass. SCR exhaust gas aftertreatment converts nitrogen oxides into harmless nitrogen and water vapour, reducing environmentally harmful emissions to a minimum.

The perfect way to plant the power on the road: 4MATIC all-wheel drive.

Whether combined with a petrol or diesel engine, the optionally available **4MATIC all-wheel drive** sends the drive power to precisely where it can be best transferred to the road. With a fixed rear-biased torque split of 45%:55% it provides an ideal blend of directional stability, dynamism and efficiency, even when there is little grip.

THE ENGINE RANGE

Diesel:

CLS 220 d with an output of 125 kW (170 hp) and 400 Nm of torque

CLS 250 d and CLS 250 d 4MATIC with an output of 150 kW (204 hp) and 500 Nm of torque

CLS 350 d with an output of 190 kW (258 hp) and 620 Nm of torque

CLS 350 d 4MATIC with an output of 190 kW (258 hp) and 620 Nm of torque

Petrol:

CLS 400 and CLS 400 4MATIC with an output of 245 kW (333 hp) and 480 Nm of torque

CLS 500 and CLS 500 4MATIC with an output of 300 kW (408 hp) and 600 Nm of torque

Mercedes-AMG CLS 63 (Coupé only) and Mercedes-AMG CLS 63 4MATIC with an output of 410 kW (557 or 585 hp) and 720 Nm of torque

Mercedes-AMG CLS 63 S 4MATIC with an output of 430 kW (585 hp) and 800 Nm of torque

↘ FIND OUT MORE

Detailed technical data for the CLS can be found on page 70/71.

An engine so powerful it deserves its own chapter: details of the Mercedes-AMG CLS 63 can be found starting on page 52.

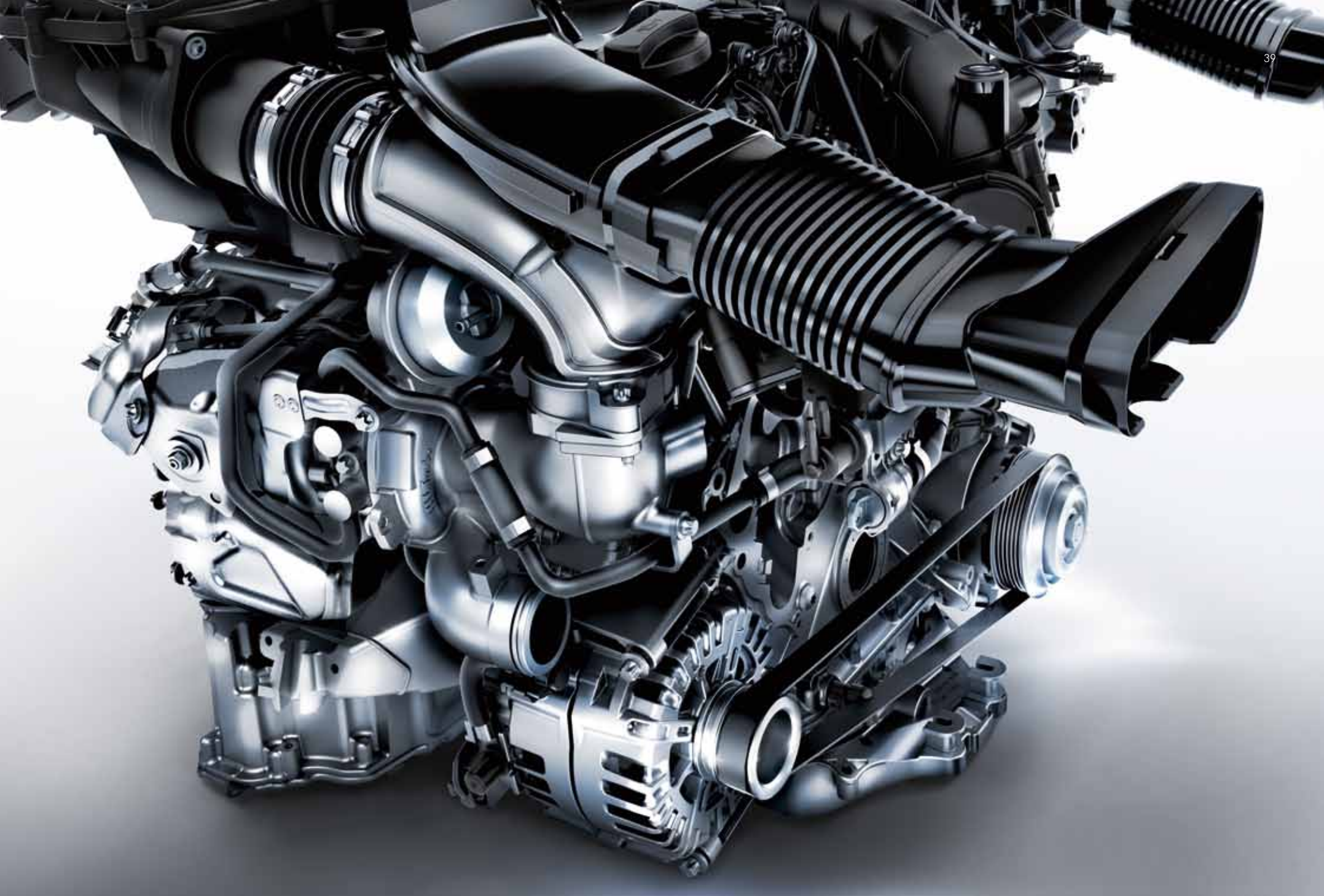



Small speed increments and a giant leap forward: the 9G-TRONIC.

The **9G-TRONIC** is the first nine-speed automatic transmission with torque converter for premium vehicles. Despite its two additional gears and the maximum transmissible torque of 1000 Nm, the 9G-TRONIC remains very light. The converter housing is made of aluminium, while the transmission housing with a weight-optimised plastic oil sump is made using an even lighter magnesium alloy.

The high efficiency helps to reduce fuel consumption. The larger ratio range allows a reduction in engine speed, resulting in enhanced ride comfort and a further reduction in the noise level. At the same time, the 9G-TRONIC impresses with its smooth, barely perceptible gear shifting. This enhanced spontaneity and agility can likewise be enjoyed in manual mode – with the **DIRECT SELECT steering wheel gearshift paddles**. The ECO start/stop function helps to reduce fuel consumption and is available in conjunction with the 9G-TRONIC as well as with the 7G-TRONIC PLUS.

7G-TRONIC PLUS TRANSMISSION

Depending on the selected model, the CLS can also be equipped with the 7G-TRONIC PLUS. Thanks to a torsional damper, it allows exceptionally comfortable and fuel-saving driving at low engine speeds. In addition, optimum vibration damping in the transmission ensures even more rapid response to accelerator commands.

↘ PLEASE NOTE:

The availability of the two transmission variants is dependent on the selected engine model. Further information can be found in the price list, in the online configurator or from your authorised Mercedes-Benz dealer. We will be pleased to advise you.



Smoothing the way: the AIRMATIC air suspension system.

With the optionally available **AIRMATIC** air suspension system (standard equipment for the CLS 500/CLS 500 4MATIC), road unevenness practically dissolves into thin air. In combination with variable damper control, it ensures ride comfort and dynamic handling at a very high level. The damping at each wheel is adapted to the current driving situation, and can be set for more comfortable or sporty characteristics as required. Hardening of the spring rate, for example on bends and when braking, effectively reduces rolling and pitching movements. Thanks to level control all-round, the vehicle maintains a constant level irrespective of the payload. The suspension level can be raised by 30 mm to increase ground clearance. At high speeds the suspension is automatically lowered by up to 20 mm, helping to reduce aerodynamic drag and improve handling.

THE DIRECT ROUTE

The **DIRECT CONTROL suspension** with selective damping system, tuned for optimum comfort, guarantees top-level comfort on long journeys in the 4- and 6-cylinder models. The vibration dampers automatically adjust to the driving conditions, thereby improving the damping effect and handling of the vehicle. Thanks to the lowering of the body by 15 mm plus the tauter suspension and damping, the **DIRECT CONTROL sports suspension** in conjunction with the Exterior Sports package or the AMG line allows a more dynamic driving style.

The **Direct-Steer system** supplements the comfort of speed-sensitive power steering with a variable ratio dependent on the steering angle, resulting in more agile vehicle response on winding routes and increased directional stability when driving straight ahead.



24 highlights: the MULTIBEAM LED light system.

Mercedes-Benz Intelligent Drive, the comprehensive networking of all the sophisticated technologies that assist and support the driver, represents a milestone on the way to accident-free driving. One example of this is the optionally available **MULTIBEAM LED** light system, which can improve visibility in a wide range of conditions. In each headlamp, 24 out of a total of 36 LEDs are controlled individually. Using data supplied by a camera on the windscreen, specially developed control units calculate the ideal light distribution for every driving situation. This enables the headlamps to react extremely quickly to the current traffic situation. On detecting that the vehicle is on a motorway, MULTIBEAM LED additionally increases the range and light output – without dazzling oncoming traffic.

The active light function with preview function (available in conjunction with the Lane Tracking package or Driving Assistance package Plus) illuminates the bend before the steering wheel is turned and prior to leaving the bend again. In particularly tight bends, when turning off and at roundabouts, the cornering light function with navigation-assisted roundabout function (available in conjunction with COMAND Online) minimises the risk of the driver overlooking something. And should fog impair visibility, the enhanced fog light function makes it easier for the driver to keep their bearings.

VIEW EVERYTHING IN A NEW LIGHT

The standard **LED High Performance headlamps** already enhance safety at night. LED technology illuminates the road ahead better than conventional headlamps – and it uses less energy.

The **LED daytime running lamps** integrated into the headlamps and the **darkened LED tail lamps** with adaptive beam intensity have an unmistakable look even when visibility is good.

The **headlamp design** in the optional MULTIBEAM LED light system creates a distinctive, unmistakable look.

Adaptive Highbeam Assist Plus (part of MULTIBEAM LED) allows main beam to be left on at all times without dazzling other road users. As a result the best possible headlamp range is always available to the driver. The function is active from a speed of 30 km/h on unlit roads.

When the car is unlocked, the **exterior welcome light** (part of MULTIBEAM LED) greets the driver with an extraordinary light show. Initially the headlamps flash yellow, then a blue LED is activated to highlight the “Mercedes-Benz” lettering, after which this transforms into the white locator lighting.

↘ **FIND OUT MORE**

For full details of Mercedes-Benz Intelligent Drive for computer, tablet or smartphone, go to www.mercedes-benz-intelligent-drive.com

You can find out everything about the innovative light system on board the CLS with the light app “CLS Light” for your iPad® – available exclusively in the iTunes Store®.

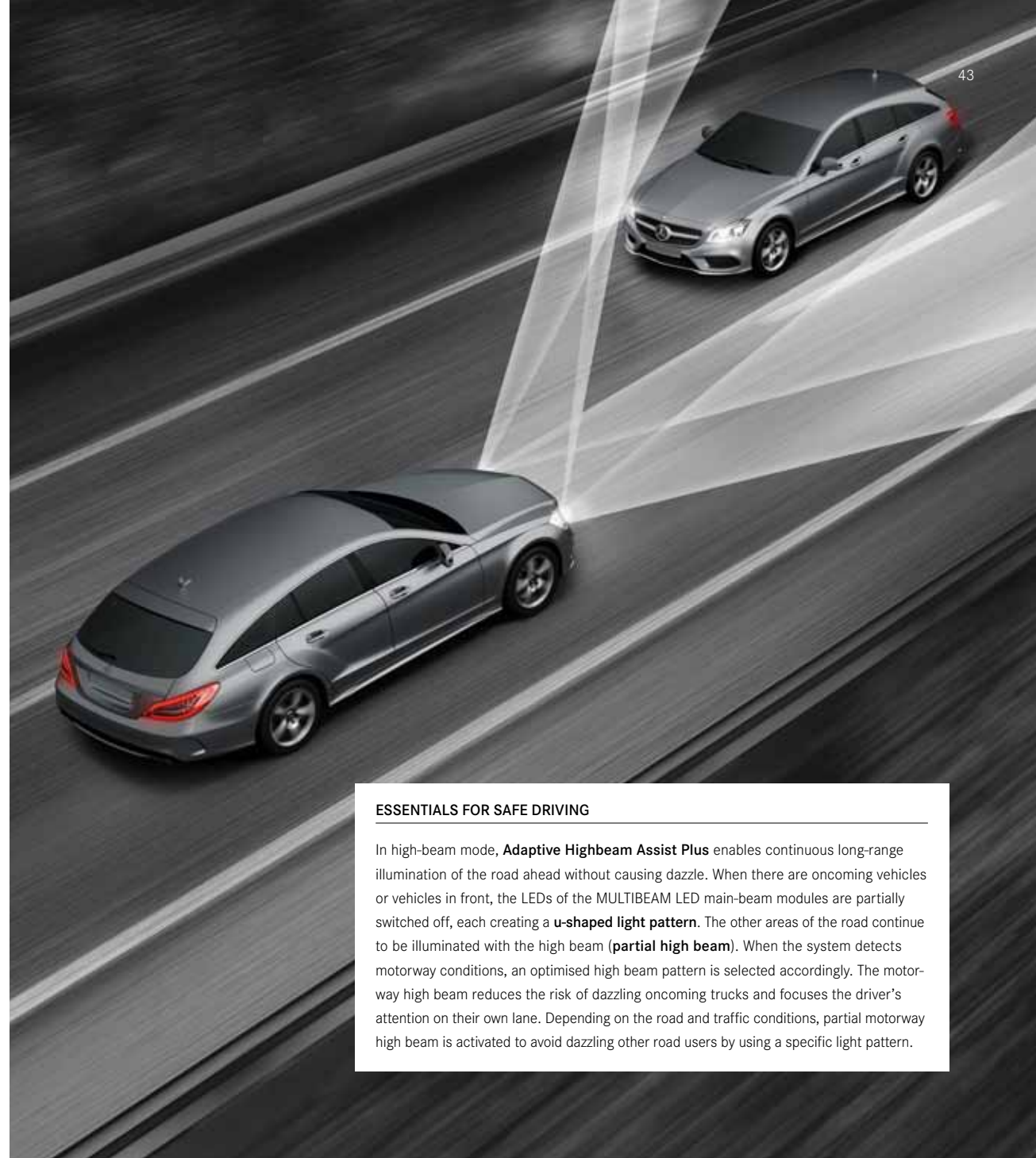

ESSENTIALS FOR SAFE DRIVING

In high-beam mode, **Adaptive Highbeam Assist Plus** enables continuous long-range illumination of the road ahead without causing dazzle. When there are oncoming vehicles or vehicles in front, the LEDs of the MULTIBEAM LED main-beam modules are partially switched off, each creating a **u-shaped light pattern**. The other areas of the road continue to be illuminated with the high beam (**partial high beam**). When the system detects motorway conditions, an optimised high beam pattern is selected accordingly. The motorway high beam reduces the risk of dazzling oncoming trucks and focuses the driver’s attention on their own lane. Depending on the road and traffic conditions, partial motorway high beam is activated to avoid dazzling other road users by using a specific light pattern.

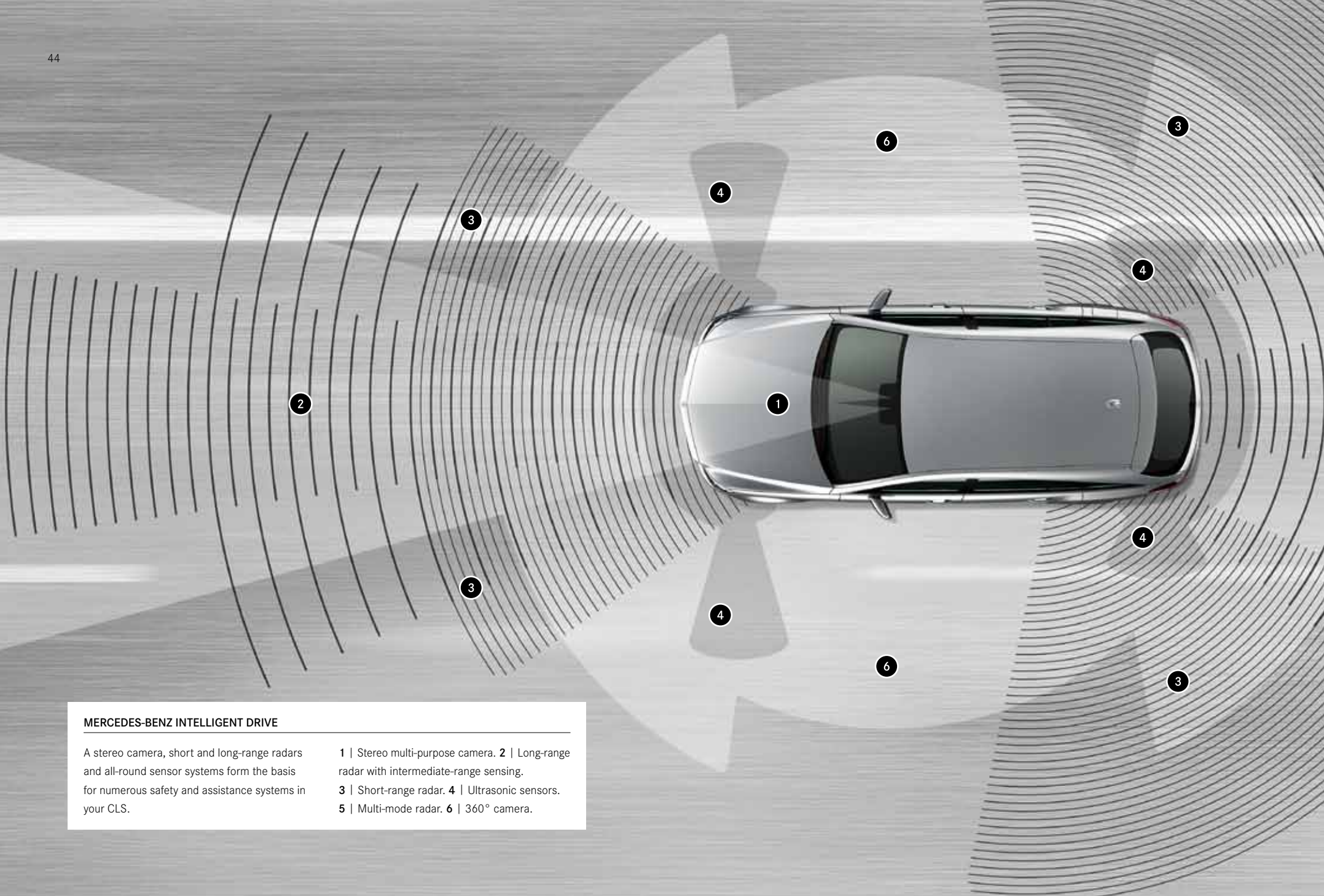

MERCEDES-BENZ INTELLIGENT DRIVE

A stereo camera, short and long-range radars and all-round sensor systems form the basis for numerous safety and assistance systems in your CLS.

1 | Stereo multi-purpose camera. 2 | Long-range radar with intermediate-range sensing.
3 | Short-range radar. 4 | Ultrasonic sensors.
5 | Multi-mode radar. 6 | 360° camera.

Driving Assistance package Plus. Positively safer.

Your eyes are focused on the road whilst driving. You look over your shoulder before overtaking. And you regularly check your rear-view mirror, not just when reversing. But even the very best drivers are unable to keep an eye on everything at the same time. Time for some enhanced protection: the optionally available **Driving Assistance package Plus** is an important component of Mercedes-Benz Intelligent Drive and comprises a wealth of complementary safety and assistance systems.

DISTRONIC PLUS with Steering Assist and Stop&Go Pilot helps you keep a safe distance from the vehicle in front and also stay in the middle of the lane, for example. In this way, the system provides a great deal of stress-relieving

comfort, especially on long journeys and when following vehicles in a traffic jam. Brake Assist BAS PLUS with Cross-Traffic Assist and PRE-SAFE® Brake with pedestrian detection can reduce the risk of accidents at junctions, rear-end collisions and collisions with pedestrians, particularly in urban traffic. Active Lane Keeping Assist and Active Blind Spot Assist provide assistance if the vehicle leaves its lane unintentionally or during lane changes if there is a danger of collision with other vehicles. One-sided braking intervention can help return the vehicle to its lane and prevent an accident. And finally, PRE-SAFE® PLUS extends the functions of the PRE-SAFE® occupant protection system with preventive measures when a rear impact threatens.

5

SAFETY TAKES PRECEDENCE

The optional **Traffic Sign Assist** system is able to recognise speed limits, no-entry and no-overtaking signs and their cancellation, and display them to the driver. If the vehicle enters a road against the posted allowed direction of travel, a visual and acoustic warning is issued.



Park like a pro thanks to 360° camera.

The optionally available **Active Parking Assist with PARKTRONIC** makes it easier to find a parking space and also to enter or leave parking spaces. When activated, it automatically steers the vehicle into parallel or end-on parking spaces, relieving the driver of the work of steering and braking. The **360° camera** included in the optional **Parking package** provides you with a realistic all-round view when parking and manoeuvring thanks to the interaction of a network of four cameras. The camera is switched on automatically when reverse gear is engaged.

Alternatively, it can be activated by the driver if required. The vehicle and its immediate surroundings can be shown as a bird's-eye view in the multimedia system display. Obstacles below the window line are also visible to the driver. If the driver does not wish to use Active Parking Assist, the PARKTRONIC electronic parking assistance system monitors the front and rear ends while the driver is manoeuvring the vehicle and warns the driver if a risk of collision is detected.

↘ FIND OUT MORE

Find free parking spaces using the **Mercedes-Benz App** for Audio 20 CD and the optional COMAND Online system. You can find the full information on this app and many others at <http://apps.mercedes-benz.com>

Information from the **Digital Owner's Manual** can be called up directly in the vehicle and viewed on the central display. This interactive feature for the CLS can be accessed from the national Mercedes-Benz website for your country, and is also available as an app for smartphone or tablet.

The reassuring feeling of driving a Mercedes-Benz.

We are the first automobile manufacturer worldwide to have developed an **integral safety concept**, aimed at avoiding accidents, ensuring ideal responses to dangers and lessening the consequences of accidents. For the occupants of a Mercedes and for all other road users, too.

SAFE DRIVING

The **ATTENTION ASSIST drowsiness detection system** can enhance driving safety, in particular on long trips and during night-time driving. It can monitor the steering behaviour of the driver to recognise typical signs of drowsiness and severe loss of attention, and give a visual and audible warning of impending microsleep.

The **ADAPTIVE BRAKE** system improves ride comfort and safety. With the anti-lock braking system (ABS) as a base function it helps the driver to master critical braking manoeuvres more safely, and also assists the driver with day-to-day convenience functions such as Hill-Start Assist.

IN THE EVENT OF DANGER

COLLISION PREVENTION ASSIST PLUS gives the driver a visual warning if the distance to the vehicle in front is too short. If the risk of a collision is detected, the driver can receive an audible warning and braking assistance. If the driver fails to react, the speed can be reduced autonomously.

The optional **Blind Spot Assist** system employs radar sensors and can draw attention to one of the most serious sources of danger in road traffic. If another vehicle is detected in the blind spot area, a red triangle appears in the relevant exterior mirror. An acoustic warning additionally sounds if the driver indicates to change lane. The system is active at speeds between 30 and 250 km/h. The optional **Lane Keeping Assist** system is able to recognise when the vehicle is unintentionally drifting out of its lane at speeds between 60 and 200 km/h, duly warning the driver by means of pulsed vibrations on the steering wheel. Blind Spot Assist and Lane Keeping Assist also form part of the optional Lane Tracking package.

The anticipatory **occupant protection system PRE-SAFE®** is able to identify critical driving situations in advance and to initiate precautionary measures to protect the vehicle's occupants if an accident appears imminent. Such measures include reversible belt tensioning or automatic closing of open side windows, for example.

IN AN ACCIDENT

Extensive restraint systems can substantially reduce the risk of injury. These include three-point seat belts with pyrotechnic belt tensioners and belt force limiters. Furthermore, the **NECK-PRO head restraints** on the front seats are actively raised and moved forward in the event of a rear impact to provide early support for the occupants' heads and reduce the risk of whiplash injuries. Numerous airbags protect the occupants in the event of an accident and can reduce the risk of serious injury.

AFTER AN ACCIDENT

Every Mercedes-Benz is perfectly trained in first aid. In the event of an accident, the engine can be shut down automatically and the central locking system can be unlocked, in addition to which the hazard warning lights and the interior emergency illumination can be activated. Finally, the **Mercedes-Benz emergency call system**, one of the Mercedes connect me Standard Services (standard specification), can send position data and important vehicle information, though it is to be hoped this will never be necessary.



Mercedes connect me. Connected in comfort.

Our innovative and individualised mobility, connectivity and services go by the name of Mercedes me. As part of this Mercedes-Benz world of experience, **Mercedes connect me** fully integrates driver, vehicle and personal lifestyle. The Mercedes connect me Standard Services, such as the Mercedes-Benz emergency call system or Breakdown Management, offer immediate assistance.

The Remote Online package prepares the vehicle for the use of other – separately available – Mercedes connect me services, such as the Parked Vehicle Locator function. Remote Online is available as an option in conjunction with the standard Audio 20 CD multimedia system and also forms an integral part of the optional COMAND Online multimedia system, so opening up to you the whole world of Mercedes connect me – including browser, navigation with Live Traffic Information (free use for three years) and numerous apps¹. The Mercedes connect me services are activated only after receiving your specific request to this effect – with the exception of the Mercedes-Benz emergency call system, which is activated automatically.

PHENOMENAL OPTIONS: THE ENTERTAINMENT HIGHLIGHTS

The 1400-watt **Bang & Olufsen BeoSound AMG** high-end surround sound system is an impressive proposition, with its 14 active high-end loudspeakers and two tweeters with LED lighting.

The **Harman Kardon® Logic 7® surround sound system** with 610-watt Harman Kardon® DSP amplifier and booster delivers authentic surround sound.

COMAND Online offers navigation, telephone, audio, video and internet on a 20.3 cm display with intuitive control via Controller and LINGUATRONIC voice-operated control system.

The **Garmin® MAP PILOT** transfers all the benefits of a Garmin® navigation system to the Audio 20 CD multimedia system – with user-friendly navigation, precise map data and excellent route guidance.

¹ The integral Mercedes-Benz Apps are subject to change.





Customised comfort.

Lapses in concentration occur sooner or later on longer trips, sometimes due to back fatigue. The optionally available **Active Multicontour Seat package** with massage and dynamic function helps to alleviate tension. Via the central display, the various air chambers in the driver and front passenger seat can be programmed with individual settings before setting off on a journey – from seat cushion depth via the side bolsters to the position and curvature of the backrest. A lumbar adjustment gives support to the spine. The massage function with seven zones and two selectable intensity settings further enhances the outstanding level of comfort on long journeys.

Do you prefer more dynamic driving? On winding routes or when adopting a sporty driving style, the seat side bolsters adjust dynamically, meaning that the active multicontour seats offer even more support, depending on the steering angle, lateral acceleration and speed of the car.



FIRST-CLASS COMFORT FOR THE SECOND ROW

Luxurious **individual rear seats** separated by a centre console with folding armrest emphasise the individuality of the entire CLS Coupé interior. Up to five people can enjoy all the CLS Shooting Brake has to offer – thanks to an **additional rear seat** in place of the centre console.

Space on demand.

The **EASY-PACK tailgate** makes it easy to carry items in the generously sized load compartment of the CLS Shooting Brake. For easy loading and unloading, it opens and closes by electro-mechanical means at the push of a button. To prevent the door from bumping against any objects, it can be stopped in any position and its opening angle can be limited up to the edge of the roof. Thanks to the separately folding **EASY-PACK quickfold rear seats** (also available for the Coupé as an option), there is an abundance of space in the load compartment – up to 1550 litres in the CLS Shooting Brake.



ELEGANT AND PRACTICAL

designo load compartment floor made from American open-pore cherry wood with black inlay work in dark fumed oak, available as an option for the CLS Shooting Brake.

Effective protection from prying eyes for the load compartment of the CLS Shooting Brake thanks to the pull-out **load compartment cover** with practical retractor mechanism.

The optionally available pull-out and height-adjustable **EASY-PACK boot box** allows smaller items such as laptops, briefcases or items of clothing to be stowed securely in the CLS Coupé so that they do not slide around (max. load capacity 10 kg, adjustable from 5 to 55 l).







Sets the heart racing. Before you even start off.

High-end wherever you look – hallmarks of the **Mercedes-AMG CLS 63** and the **Mercedes-AMG CLS 63 4MATIC**. The front apron in A-wing design, the AMG light-alloy wheels and the AMG performance steering wheel are just three examples.

HIGHLIGHTS – EXTERIOR

- AMG radiator grille with silver chrome double louvre and “AMG” lettering
- AMG front apron in A-wing design with trim strip in silver chrome, flics in black
- AMG side sill panels and wider front wings
- AMG triple-spoke light-alloy wheels, painted in titanium grey with a high-sheen finish, with 255/35 R 19 front tyres and 285/30 R 19 rear tyres
- AMG rear apron with diffuser insert and AMG sports exhaust system with two chrome-plated twin tailpipe trim elements
- AMG spoiler lip on the boot lid (Coupé)

HIGHLIGHTS – INTERIOR

- AMG instrument cluster with AMG main menu, including RACETIMER and AMG start-up display
- AMG performance steering wheel in nappa leather, in 3-spoke design with flattened bottom section
- AMG DRIVE UNIT with E-SELECT lever
- AMG sports seats in perforated PASSION leather with multicontour seat and memory function
- AMG sports pedals in brushed stainless steel with rubber studs



The stuff of dreams: the AMG Night package.

From the race track directly to your dinner appointment: the optionally available AMG Night package highlights the expressive and sporty character of the AMG models in extravagant fashion. With design elements painted in high-gloss black for drivers with exquisite taste.



AMG NIGHT PACKAGE AT A GLANCE

A-wing of AMG front apron and A-wing trim strip in high-gloss black

AMG side sill panel inserts in high-gloss black

Exterior mirror housings in high-gloss black

Window surrounds and beltline trim strips in high-gloss black

A tantalisingly lightweight option: the AMG Carbon-Fibre packages.

Elegance with a bold, sporty note: high-quality details in carbon fibre available as an option lend the AMG models even more dynamism when viewed from any angle, providing effective contrasts with the distinctive carbon structure trim.

AMG EXTERIOR CARBON-FIBRE PACKAGE I (ONLY AVAILABLE FOR COUPÉ)

AMG front apron A-wing in carbon fibre

Inserts in AMG side sill panels in carbon fibre

Carbon-fibre diffuser insert in AMG rear apron

AMG EXTERIOR CARBON-FIBRE PACKAGE II (ONLY AVAILABLE FOR COUPÉ)

AMG carbon-fibre exterior mirror housings

AMG spoiler lip in carbon fibre

AMG EXTERIOR CARBON-FIBRE PACKAGE (ONLY AVAILABLE FOR SHOOTING BRAKE)

AMG front apron A-wing in carbon fibre

Inserts in AMG side sill panels in carbon fibre

Carbon-fibre diffuser insert in AMG rear apron

ALSO AVAILABLE FOR SHOOTING BRAKE

AMG carbon-fibre exterior mirror housings







Super athlete on the outside. Superior on the inside.

The **Mercedes-AMG CLS 63 S 4MATIC** has the air of an exceptional athlete. And this impression is not a misleading one. Thanks to the V8 engine with 430 kW (585 hp) and the combination of the traction benefits of an all-wheel-drive vehicle with the driving enjoyment provided by a rear axle differential lock. One thing becomes clear just hundredths of a second after getting in: you have already reached your most exciting destination.

HIGHLIGHTS - EXTERIOR

AMG 10-spoke light-alloy wheels, painted in matt titanium grey, rim flange with a high-shine finish, with 255/35 R 19 front tyres and 285/30 R 19 rear tyres

AMG Performance 4MATIC all-wheel drive with AMG rear axle differential lock

Brake callipers painted red

AMG sports exhaust system with two chrome-plated twin tailpipe trim elements

HIGHLIGHTS - INTERIOR

AMG door sill panels, with white LED illumination at the front

AMG instrument cluster with red appliqués and "S-Model" lettering

AMG performance steering wheel in black nappa leather/DINAMICA microfibre, with 3 spokes and flattened bottom section

Interior with light contrasting topstitching and silver-coloured seat belts (not in conjunction with silk beige)

Mercedes-AMG CLS 63 – technical features.

The Mercedes-AMG CLS 63 reconciles apparent contradictions such as unbridled power and restrained fuel consumption, race-track performance and functionality. Its **AMG 5.5-litre V8 biturbo engine** has an output of 410 kW (557 hp) and generates 720 Nm of torque or, in the S-Model, a staggering 430 kW (585 hp) and 800 Nm of torque.

The Mercedes-AMG-developed **performance-oriented 4MATIC all-wheel drive** (Mercedes-AMG CLS 63 4MATIC and Mercedes-AMG CLS 63 S 4MATIC) with a torque split of 33 : 67 provides the ideal means of transferring this power to the road – or to the race track.

With seven gears, four modes, RACE START function and double declutching function, the **AMG SPEEDSHIFT MCT 7-speed sports transmission** allows extremely dynamic acceleration, short shift times and a fuel-saving driving style.

With its adjustable, electronically controlled damping system, the **AMG RIDE CONTROL sports suspension** ensures both exciting driving dynamics and the brand's hallmark comfort on long journeys. The front axle features steel suspension while the rear axle has AMG-specific air suspension.



AMG Performance Studio.

The AMG Performance Studio provides a wide variety of options to enhance the attractiveness, performance and exclusivity of the CLS 63 AMG even further – from the AMG RIDE CONTROL performance suspension and the AMG ceramic high-performance composite braking system through to the AMG performance steering wheel in black nappa leather/DINAMICA microfibre. The AMG Performance Studio is also able to cater for individual customer requirements.

AMG ceramic high-performance composite braking system
(Mercedes-AMG CLS 63 S 4MATIC)

AMG rear axle differential lock (Mercedes-AMG CLS 63 Coupé)

AMG RIDE CONTROL performance suspension with tauter tuning
(Mercedes-AMG CLS 63 Coupé)

AMG Driver's package with increase in top speed to 300 km/h (Shooting Brake 280 km/h) and participation in driver training at the AMG Driving Academy

AMG 10-spoke light-alloy wheels, painted in matt black, rim flange with a high-sheen finish, with 255/35 R 19 front tyres and 285/30 R 19 rear tyres

AMG cross-spoke forged wheels, either painted titanium grey with a high-sheen surface finish or painted matt black with a rim flange with a high-sheen finish, in each case with 255/35 R 19 front tyres and 285/30 R 19 rear tyres

AMG performance steering wheel in black nappa leather/DINAMICA microfibre, with 3 spokes and flattened bottom section

AMG carbon-fibre/black piano lacquer trim

AMG door sill panels, with white LED illumination at the front





Standard-fit head-turners.

With a new progressively dynamic front, LED High Performance headlamps and LED tail lamps, the CLS boasts a comprehensive range of details even in its standard specification.

- 1 The exciting exterior features a black diamond radiator grille, LED High Performance headlamps plus 25R/69R (Coupé) or 69R (Shooting Brake) light-alloy wheels.
- 2 Of the twelve ergonomic function keys on the nappa leather **multifunction steering wheel**, the left-hand array controls the display menus in the instrument cluster. The keys on the right-hand side are used, for example, to adjust the volume for audio devices, the telephone and the navigation system. Manual gear changes are also possible using the DIRECT SELECT steering wheel gearshift paddles.
- 3 The **Audio 20 CD** multimedia system with 20.3 cm display combines entertainment, information and communication. The functions: radio, CD player, two USB connections (e.g. for external audio devices such as iPod® or iPhone®), SD card connection, hands-free function, internet capability and networking with mobile devices via Bluetooth®.
- 4 **THERMATIC** automatic climate control with two climate zones. Temperature, airflow and air distribution are controlled automatically.
- 5 The **EASY-PACK quickfold** rear seats make it easier to transport bulky items. To enable the greatest possible flexibility the two backrest sections can be folded down separately using the convenient controls in the boot, and without the head restraints having to be removed beforehand (optional in Coupé).

↘ FIND OUT MORE

As attractive as this overview may be, it only provides an initial impression. For the complete range of standard equipment please refer to the price list, which is also available for viewing online. You can also configure your CLS to your very own specifications via www.mercedes-benz.com



Everything you could wish for: the optional extras.

THERMOTRONIC, MULTIBEAM LED, COMAND Online – technical features that tangibly enhance your comfort, safety and multimedia options. Meaning more of your wishes can be fulfilled. Discover these and other individualisation options – in this brochure, in the price list or online.

- 1 **COMAND Online** with 20.3 cm display, navigation, telephone, audio, video, internet and much more besides. **Climatised seats**. **THERMOTRONIC** automatic climate control with three climate zones and three climate styles. **KEYLESS-GO** enables the vehicle to be opened, started and locked simply by carrying the electronic key with you.
- 2 **Heat-insulating, dark-tinted glass** in the rear side windows and rear window protects the rear seat passengers from prying eyes and direct sunlight.
- 3 The electric **sliding sunroof** provides pleasant, draught-free air circulation in the interior. The glass design means that the interior also has a brighter look and feel. A movable headlining affords protection against the sun. If it starts to rain, the roof automatically moves to the raised position.
- 4 The **MULTIBEAM LED** light system enables the headlamps to adjust quickly and precisely to the current traffic situation (further details on pages 4 and 42/43).
- 5 In the CLS Shooting Brake, the perceived quality of the luggage compartment can be enhanced further by the added design feature of **four aluminium rails** on the load compartment floor. Thanks to rubber inserts they offer additional slip-resistance when transporting loads.





A beauty to behold: the Exclusive package.

A Mercedes-Benz is always something special. But this stylishly matched combination of choice materials and lavish details means that even the aesthetics of a CLS can be further enhanced.

Upholstery in single-tone Exclusive PASSION leather with high-quality seat cushions in semi-aniline leather (optional: upholstery in two-tone Exclusive PASSION leather)

Dashboard, beltline, door centre panels, armrests in the doors and centre console finished in nappa leather

Nappa leather multifunction steering wheel

Multifunction sports steering wheel in nappa leather, with flattened bottom section (in conjunction with AMG Line or designo upholstery)

Optional: wood/leather steering wheel (not in conjunction with Mercedes-AMG CLS 63, AMG Line or designo upholstery)

Ambient lighting

DINAMICA microfibre roof liner in black, crystal grey or silk beige depending on appointments colour

Velour floor mats in appointments colour, with nubuck border

Floor mats with "AMG" lettering (in conjunction with Mercedes-AMG CLS 63 or AMG Line)



Thrills in the fast lane: the Exterior Sports package.

The first impression is all-decisive in a fraction of a second. Eye-catching sporty touches for the 4- and 6-cylinder models.



1 Twin-pipe exhaust system with integrated rectangular polished stainless-steel tailpipe trim elements with black rear bumper insert, DIRECT CONTROL sports suspension (no-cost option: DIRECT CONTROL suspension with comfort-oriented tuning), brake callipers with "Mercedes-Benz" lettering and larger front brake discs



2 5-twin-spoke light-alloy wheels painted Himalayas grey with a high-shine finish, with 255/40 R 18 front tyres and 285/35 R 18 rear tyres

3 10-spoke light-alloy wheels painted Himalayas grey with a high-shine finish, with 255/40 R 18 front tyres and 285/35 R 18 rear tyres (option)

4 5-twin-spoke light-alloy wheels painted Himalayas grey with a high-shine finish, with 255/35 R 19 front tyres and 285/30 R 19 rear tyres (option)

5 5-twin-spoke light-alloy wheels painted Himalayas grey with a high-shine finish, with 255/35 R 19 front tyres and 285/30 R 19 rear tyres (option)

The ultimate in dynamism: AMG Line and AMG Line Plus.

Turn the CLS into a top athlete – with the AMG Line or its enhanced version, the AMG Line Plus.

1 HIGHLIGHTS OF THE AMG LINE

AMG bodystyling consisting of AMG front apron, diamond radiator grille in chrome, AMG rear apron with chrome trim and AMG side sill panels

AMG 5-spoke light-alloy wheels with 255/40 R 18 front tyres and 285/35 R 18 rear tyres, AMG multi-spoke light-alloy wheels with 255/35 R 19 front tyres and 285/30 R 19 rear tyres (option)

Twin-pipe exhaust system with rectangular polished stainless-steel tailpipe trim elements integrated into the bumper

DIRECT CONTROL sports suspension

3-spoke multifunction sports steering wheel in nappa leather, with flattened bottom section

Interior with light contrasting topstitching (in conjunction with black upholstery)

2-4 HIGHLIGHTS OF THE AMG LINE PLUS

AMG spoiler lip on boot lid (Coupé), AMG 7-twin-spoke light-alloy wheels, painted high-gloss black with a high-sheen finish, with 255/35 R 19 front tyres and 285/30 R 19 rear tyres

3-spoke AMG sports steering wheel in nappa leather, with red contrasting topstitching and flattened bottom section

Seat belts in red (optionally in black)

AMG sports seats with black leather upholstery and interior with red contrasting topstitching



Athlete in black: the Night package.

Striking design elements in black underscore the sporty, expressive character of the CLS in conjunction with the AMG Line or the CLS 500 – from the louvre in the radiator grille to the exterior mirrors and the light-alloy wheels.

1 Louvre in the radiator trim painted high-gloss black, front splitter in front bumper painted in high-gloss black, exterior mirrors painted in high-gloss black (painted in body colour in conjunction with obsidian black), beltline trim strip and window surrounds in anodised black, AMG 7-twin-spoke light-alloy wheels painted high-gloss black with a high-sheen finish, with 255/35 R 19 front tyres and 285/30 R 19 rear tyres (wheels optional for Night package in conjunction with AMG Line, standard for Night package in conjunction with AMG Line Plus)

2 Trim strip on AMG rear apron painted high-gloss black, heat-insulating dark-tinted glass from the B-pillar rearwards (can be deselected on request), AMG 5-spoke light-alloy wheels painted black with a high-sheen finish, with 255/40 R 18 front tyres and 285/35 R 18 rear tyres (wheels part of Night package in conjunction with AMG Line)

3 5-twin spoke light-alloy wheels painted black with a high-sheen finish, with 255/40 R 18 front tyres and 285/35 R 18 rear tyres, part of Night package in conjunction with CLS 500/CLS 500 4MATIC

4 5-twin spoke light-alloy wheels painted black with a high-sheen finish, with 255/35 R 19 front tyres and 285/30 R 19 rear tyres, option for Night package in conjunction with CLS 500/CLS 500 4MATIC





Turning the design icon into a designer piece: designo.

The designo range for the CLS gives you options for further enhancing the car with exclusive and individual appointments. The two designo interior concepts with upholstery in fine designo semi-aniline leather (diamond design) or the finest designo nappa leather for the AMG models (piping design) impress with their stylish mix of contrasting colours and high-quality contrasting topstitching, for example.

THE EXTRAS OF YOUR CHOICE

The designo paint finishes are available in six colours.

The interior in classic red/black boasts a progressively sporty ambience. Here the seats and door centre panels in classic red plus red topstitching create an effective contrast against the black interior, inclusive of its high-gloss black ash wood trim.

For stylish luxury: the variant in saddle brown/silk beige with satin-finish light brown poplar wood trim (the pictures show the optional high-gloss brown linestructure lime wood trim). In addition to the seats, there are further elements finished in saddle brown such as the upper part of the dashboard and the beltlines.

Simply divine: designo DINAMICA microfibre roof liner, available in black, silk beige or crystal grey

DISCOVER ALL THE BEAUTY OF DESIGNO

Configure your choice of interior appointments at

www.mercedes-benz.com or speak to your nearest authorised Mercedes-Benz dealer.

The real thing or nothing: Genuine Accessories.

Given that the CLS is such a masterpiece of engineering, the accessories should be of equally outstanding quality. And ours are. The **Apple iPad® Rear Integration Plus** docking station is an ergonomic and crash-resistant solution for attaching your iPad®, for instance. The holder can be tilted as well as rotated through 90°, and it keeps all the connections accessible. Plus the battery can be charged via an integrated USB interface using your charging cable.

FROM MERCEDES – FOR MERCEDES

The **5-twin-spoke light-alloy wheels** are painted Himalayas grey with a high-sheen finish. Their tyres: 255/40 R 18 (front) and 285/35 R 18 (rear).

The **multi-spoke light-alloy wheels** are painted Himalayas grey. Their tyres: 255/35 R 19 (front) and 285/30 R 19 (rear).

The **rear spoiler** from Mercedes-Benz further improves the aerodynamics of the CLS Coupé. It blends in harmoniously with the contours of the car to create an exceptionally sporty design.

Illuminated Mercedes star: the star centred in the radiator grille will light up courtesy of fibre-optic and LED technology when the vehicle is locked and unlocked by remote control, and when a door, the boot lid or the tailgate is opened.

Aerodynamic **roof box** designed to fit the CLS, made from extremely durable material. Fast, optimised attachment to the separately available basic carrier bars. Easy loading and unloading, as it can be opened and closed on both sides.

DISCOVER THE ENTIRE RANGE

Now online at www.mercedes-benz-accessories.com





The perfect way to round off your style.

Wheels are indispensable on technical grounds, of course. But on an emotional level, too, perfect wheels are an absolutely crucial ingredient of many people's dream car. With this in mind, we have put together an attractive selection for you.

STANDARD EQUIPMENT AND OPTIONAL EXTRAS

25R 10-spoke light-alloy wheels, painted titanium grey, with 245/45 R 17 tyres (standard for 4-cylinder CLS Coupé models)

69R Multi-spoke light-alloy wheels, painted silver, with 245/45 R 17 tyres (CLS Coupé: standard for 6-cylinder models, option for 4-cylinder models; CLS Shooting Brake: standard for 4- and 6-cylinder models)

40R Multi-spoke light-alloy wheels, painted silver, with 255/40 R 18 tyres (standard for CLS 500/CLS 500 4MATIC, option for 4- and 6-cylinder models)

R71 10-spoke light-alloy wheels painted Himalayas grey with a high-sheen finish, with 255/40 R 18 front tyres and 285/35 R 18 rear tyres (option)

22R 5-twin-spoke light-alloy wheels painted Himalayas grey with a high-sheen finish, with 255/40 R 18 front tyres and 285/35 R 18 rear tyres (option, part of Exterior Sports package)

83R 5-twin-spoke light-alloy wheels painted black with a high-sheen finish, with 255/40 R 18 front tyres and 285/35 R 18 rear tyres (part of Night package in conjunction with CLS 500/CLS 500 4MATIC)

R90 5-twin-spoke light-alloy wheels painted Himalayas grey with a high-sheen finish, with 255/35 R 19 front tyres and 285/30 R 19 rear tyres (option)

R17 5-twin-spoke light-alloy wheels painted Himalayas grey with a high-sheen finish, with 255/35 R 19 front tyres and 285/30 R 19 rear tyres (option)

84R 5-twin-spoke light-alloy wheels painted black with a high-sheen finish, with 255/35 R 19 front tyres and 285/30 R 19 rear tyres (option for Night package in conjunction with CLS 500/CLS 500 4MATIC)



782



644



662



752 72R



69



788



797



799



665 R70



AMG

790 AMG 5-spoke light-alloy wheels painted titanium grey, with 255/40 R 18 front tyres and 285/35 R 18 rear tyres (part of AMG Line)

782 AMG 5-spoke light-alloy wheels painted black with a high-sheen finish, with 255/40 R 18 front tyres and 285/35 R 18 rear tyres (part of Night package in conjunction with AMG Line)

788 AMG multi-spoke light-alloy wheels painted titanium grey, with 255/35 R 19 front tyres and 285/30 R 19 rear tyres (option in conjunction with AMG Line)

644 AMG 7-twin-spoke light-alloy wheels painted high-gloss black with a high-sheen finish, with 255/35 R 19 front tyres and 285/30 R 19 rear tyres (part of AMG Line Plus, option for Night package in conjunction with AMG line)

797 AMG triple-spoke light-alloy wheels painted titanium grey with a high-sheen finish, with 255/35 R 19 front tyres and 285/30 R 19 rear tyres (standard for Mercedes-AMG CLS 63 Coupé and Mercedes-AMG CLS 63 4MATIC)

662 AMG 10-spoke light-alloy wheels painted matt titanium grey, rim flange with a high-sheen finish, with 255/35 R 19 front tyres and 285/30 R 19 rear tyres (standard for Mercedes-AMG CLS 63 S 4MATIC)

799 AMG cross-spoke forged wheels painted titanium grey with high-sheen surface, with 255/35 R 19 front tyres and 285/30 R 19 rear tyres (option for AMG models)

752 AMG 10-spoke light-alloy wheels painted matt black, rim flange with high-sheen finish, with 255/35 R 19 front tyres and 285/30 R 19 rear tyres (option for AMG models)

665 AMG cross-spoke forged wheels painted matt black, rim flange with high-sheen finish, with 255/35 R 19 front tyres and 285/30 R 19 rear tyres (option for AMG models)

GENUINE ACCESSORIES

72R 10-spoke light-alloy wheels painted titanium silver, with 245/45 R 17 tyres (accessory wheels optional ex factory for 4- and 6-cylinder models)

R70 5-twin-spoke light-alloy wheels painted titanium silver, with 255/40 R 18 front tyres and 285/35 R 18 rear tyres (accessory wheels optional ex factory)

↘ FURTHER WHEELS

can be found on page 67 or in our range of accessories at

www.mercedes-benz-accessories.com

Technical data.

DIESEL ENGINES

	CLS 220 d	CLS 250 d	CLS 250 d 4MATIC	CLS 350 d	CLS 350 d 4MATIC
No. of cylinders/arrangement	4/in-line	4/in-line	4/in-line	6/V	6/V
Total displacement in cc	2143	2143	2143	2987	2987
Rated output ¹ in kW (hp) at rpm	125 (170)/3000–4200	150 (204)/3800	150 (204)/3800	190 (258)/3400	190 (258)/3400
Rated torque ¹ in Nm at rpm	400/1400–2800	500/1600–1800	500/1600–1800	620/1600–2400	620/1600–2400
Transmission	9G-TRONIC	9G-TRONIC	7G-TRONIC PLUS	9G-TRONIC	9G-TRONIC
Acceleration from 0 to 100 km/h in sec. [Shooting Brake]	8.3 [8.6]	7.5 [7.7]	7.9 [8.1]	6.5 [6.6]	6.4 [6.5]
Top speed, approx. in km/h [Shooting Brake]	226 [220]	242 [235]	236 [229]	250 ² [245]	2502 [247]
Tyre size, front	245/45 R 17	245/45 R 17	245/45 R 17	245/45 R 17	245/45 R 17
Tyre size, rear	245/45 R 17	245/45 R 17	245/45 R 17	245/45 R 17	245/45 R 17
Fuel	Diesel	Diesel	Diesel	Diesel	Diesel
Fuel consumption ³ in l/100 km					
Urban [Shooting Brake]	5.6–5.5 [5.7–5.6]	5.6–5.5 [5.8–5.7]	6.4 [6.8–6.7]	6.5–6.3 [6.5]	7.3–7.2 [7.4–7.3]
Extra-urban [Shooting Brake]	4.2–4.1 [4.4–4.3]	4.2–4.1 [4.5–4.4]	4.6–4.5 [5.1–4.9]	5.0–4.7 [5.1–5.0]	5.7–5.4 [5.9–5.7]
Combined [Shooting Brake]	4.7–4.6 [4.8–4.7]	4.7–4.6 [4.9–4.8]	5.3 [5.7–5.5]	5.5–5.3 [5.7–5.6]	6.2–5.9 [6.4–6.2]
CO ₂ emissions ³ in g/km, combined [Shooting Brake]	123–120 [127–125]	123–120 [130–128]	140–139 [147–144]	142–137 [149–145]	166–159 [172–165]
Emission class ⁴ /Efficiency class ⁵ [Shooting Brake]	Euro 6/A+ [Euro 6/A+]	Euro 6/A+ [Euro 6/A+]	Euro 6/A [Euro 6/A]	Euro 6/A [Euro 6/A]	Euro 6/B [Euro 6/B]
Tank capacity, of which reserve, approx. in l	59/8.0	59/8.0	59/8.0	59/8.0	59/8.0
Boot capacity ⁶ in l [Shooting Brake]	475 [590–1550]	475 [590–1550]	475 [590–1550]	475 [590–1550]	475 [590–1550]
Kerb weight ⁷ in kg [Shooting Brake]	1790 [1845]	1815 [1885]	1875 [1955]	1845 [1935]	1895 [1995]
Perm. GVW in kg [Shooting Brake]	2275 [2370]	2300 [2410]	2360 [2480]	2330 [2460]	2380 [2520]

The best for the engine:
Mercedes-Benz genuine engine oils.

¹ Figures for rated output and rated torque in accordance with Directive 80/1269/EEC in the currently applicable version. ² Electronically governed. ³ The figures shown were obtained in accordance with the prescribed measuring process (Directive [EC] 715/2007 in the currently applicable version). Note according to Directive 1999/94/EC in the currently applicable version: The figures are not based on an individual vehicle and do not constitute part of the product offer; they are provided solely for purposes of comparison between the different vehicle models. ⁴ Data applicable within the European Union only. Information may vary from country to country.

PETROL ENGINES

	CLS 400	CLS 400 4MATIC	CLS 500	CLS 500 4MATIC	Mercedes-AMG CLS 63	Mercedes-AMG CLS 63 4MATIC	Mercedes-AMG CLS 63 S 4MATIC
No. of cylinders/arrangement	6/V	6/V	8/V	8/V	8/V	8/V	8/V
Total displacement in cc	3498	3498	4663	4663	5461	5461	5461
Rated output ¹ in kW (hp) at rpm	245 (333)/5250-6000	245 (333)/5250-6000	300 (408)/5000-5750	300 (408)/5000-5750	410 (557)/5500	410 (557)/5500	430 (585)/5500
Rated torque ¹ in Nm at rpm	480/1200-4000	480/1200-4000	600/1600-4750	600/1600-4750	720/1750-5250	720/1750-5250	800/1750-5000
Transmission	7G-TRONIC PLUS	7G-TRONIC PLUS	9G-TRONIC	9G-TRONIC	AMG SPEEDSHIFT MCT 7-speed sports transmission	AMG SPEEDSHIFT MCT 7-speed sports transmission	AMG SPEEDSHIFT MCT 7-speed sports transmission
Acceleration from 0 to 100 km/h in sec. [Shooting Brake]	5.3 [5.4]	5.3 [5.4]	4.8 [4.9]	4.8 [4.8]	4.2 [-]	3.7 [3.8]	3.6 [3.7]
Top speed, approx. in km/h [Shooting Brake]	250 ² [250 ²]	250 ² [250 ²]	250 ² [250 ²]	250 ² [250 ²]	250 ² [-]	250 ² [250 ²]	250 ² [250 ²]
Tyre size, front	245/45 R 17	245/45 R 17	255/40 R 18	255/40 R 18	255/35 ZR 19	255/35 ZR 19	255/35 ZR 19
Tyre size, rear	245/45 R 17	245/45 R 17	255/40 R 18	255/40 R 18	285/30 ZR 19	285/30 ZR 19	285/30 ZR 19
Fuel	Premium petrol	Premium petrol	Premium petrol	Premium petrol	Premium plus petrol	Premium plus petrol	Premium plus petrol
Fuel consumption ³ in l/100 km							
Urban [Shooting Brake]	9.7-9.6 [9.9-9.8]	10.3-10.2 [10.6-10.5]	12.0-11.7 [12.4-12.1]	12.7-12.5 [12.8-12.7]	14.2-14.0 [-]	14.5-14.3 [14.7-14.5]	14.5-14.3 [14.7-14.5]
Extra-urban [Shooting Brake]	5.7-5.6 [5.9-5.8]	6.4-6.2 [6.7-6.5]	6.7-6.6 [6.9-6.8]	7.5-7.1 [7.8-7.5]	7.7-7.6 [-]	8.2-8.0 [8.5-8.4]	8.2-8.0 [8.5-8.4]
Combined [Shooting Brake]	7.2-7.1 [7.4-7.3]	7.9-7.8 [8.2-8.0]	8.7-8.5 [8.9-8.8]	9.3-9.1 [9.6-9.3]	10.1-9.9 [-]	10.5-10.3 [10.8-10.6]	10.5-10.3 [10.8-10.6]
CO ₂ emissions ³ in g/km, combined [Shooting Brake]	167-164 [171-169]	182-179 [190-186]	202-198 [209-205]	219-213 [225-219]	234-230 [-]	244-239 [251-247]	244-239 [251-247]
Emission class ⁴ /Efficiency class ⁵ [Shooting Brake]	Euro 6/C [Euro 6/C]	Euro 6/C [Euro 6/C]	Euro 6/D [Euro 6/D]	Euro 6/E [Euro 6/E]	Euro 6/F [-]	Euro 6/F [Euro 6/F]	Euro 6/F [Euro 6/F]
Tank capacity, of which reserve, approx. in l	59/8.0	59/8.0	80/9.0	80/9.0	66/14.0	66/14.0	66/14.0
Boot capacity ⁶ in l [Shooting Brake]	520 [590-1550]	520 [590-1550]	520 [590-1550]	520 [590-1550]	520 [-]	520 [550-1550]	520 [550-1550]
Kerb weight ⁷ in kg [Shooting Brake]	1775 [1845]	1835 [1915]	1890 [1955]	1940 [2005]	1870 [-]	1945 [2025]	1945 [2025]
Perm. GVW in kg [Shooting Brake]	2260 [2370]	2320 [2440]	2375 [2480]	2425 [2530]	2390 [-]	2415 [2560]	2415 [2560]

⁵ Determined on the basis of the measured CO₂ emissions, taking into account the mass of the vehicle. ⁶ Figures according to Directive 70/156/EEC as amended by 2000/40/EC. ⁷ Figures according to Directive 92/21/EC in the version 95/48/EC (kerb weight with fuel tank 90% full, driver, 68 kg, and luggage, 7 kg) for vehicles in standard specification. Optional extras and accessories will generally increase this figure and reduce the payload capacity accordingly. Figures in square brackets refer to the CLS Shooting Brake. Further technical data are available at www.mercedes-benz.com

Coupé dimensions.

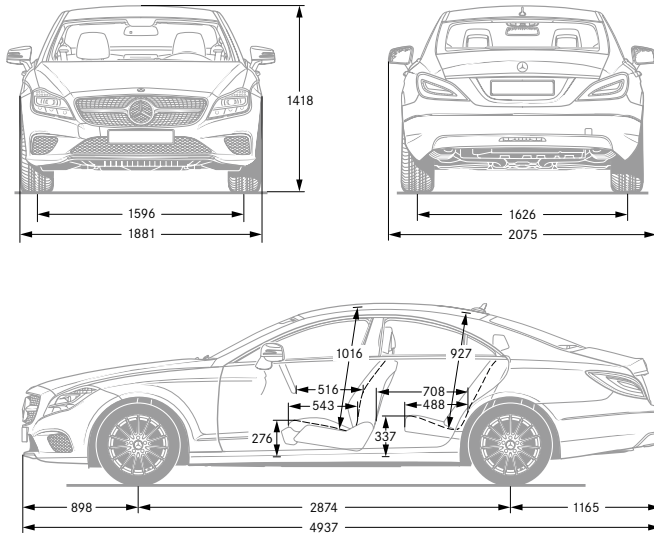

Shooting Brake dimensions.

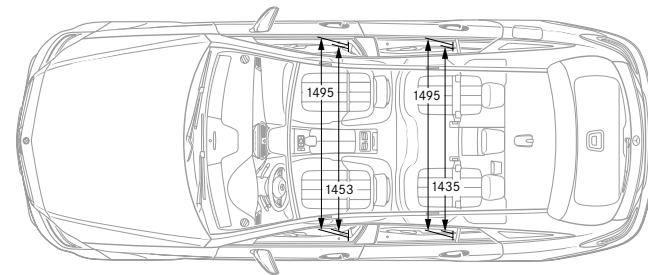
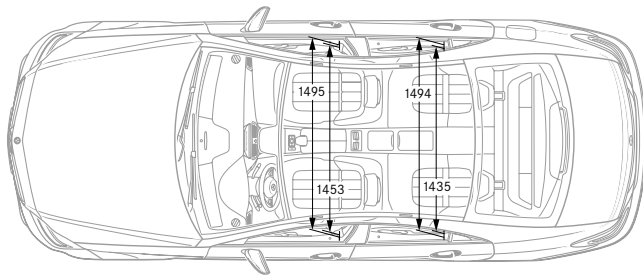
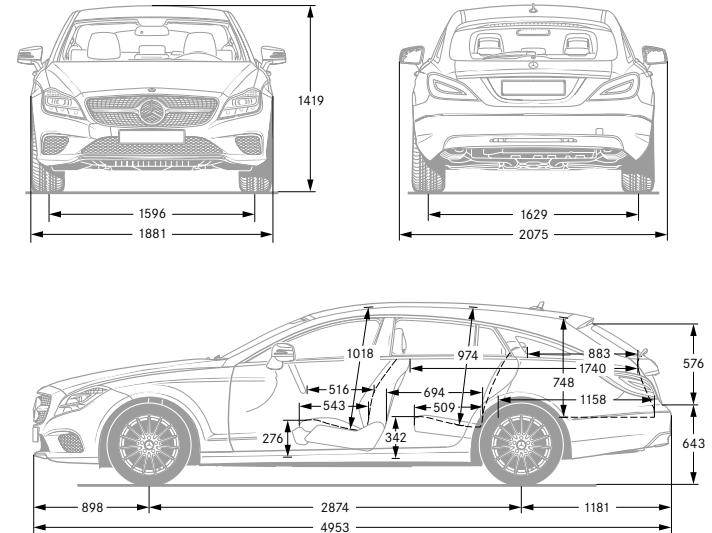

All dimensions in millimetres. The dimensions shown are mean values and apply to standard-specification, unladen vehicles.

Upholstery and trim.

Upholstery

201	black ^{1, 2}
211	black with light contrasting topstitching ^{1, 3}
214	saddle brown/black ¹
218	crystal grey/black ¹
221	black with red contrasting topstitching ^{1, 4}
225	porcelain/black ¹
245	silk beige/espresso brown ¹
501	black ^{5, 6}
511	black with light contrasting topstitching ^{1, 3, 6}
514	saddle brown/black ^{1, 6}
518	crystal grey/black ^{5, 6}
521	black with red contrasting topstitching ^{1, 4, 6}
525	porcelain/black ^{1, 6}
531	black with light contrasting topstitching ^{6, 7}
545	silk beige/espresso brown ^{5, 6}
701	black
801	black ^{5, 8}
811	black with light contrasting topstitching ^{1, 3}
814	saddle brown/black ¹

818	crystal grey/black ⁵
825	porcelain/black ¹
831	black with light contrasting topstitching ⁹
845	silk beige/espresso brown ⁵
851	black with red contrasting topstitching ^{1, 4}
964	saddle brown/silk beige ^{1, 6}
967	classic red/black ^{1, 6}
974	saddle brown/silk beige ¹
977	classic red/black ¹
984	saddle brown/silk beige ^{6, 10}
987	classic red/black ^{6, 10}
994	saddle brown/silk beige ¹⁰
997	classic red/black ¹⁰

Trim

H07	high-gloss brown linestructure lime wood ⁵
H19	satin-finish light brown poplar wood ¹¹
H21	black piano lacquer ^{5, 8}
H73	AMG carbon fibre/black piano lacquer ⁵
731	high-gloss brown burr walnut wood ¹¹
736	high-gloss black ash wood ¹²

ARTICO man-made leather/fabric



Leather



¹ Option, not available for AMG models. ² Standard for CLS 500/CLS 500 4MATIC. ³ Only in conjunction with AMG Line. ⁴ Only in conjunction with AMG Line Plus.
⁵ Option. ⁶ Only in conjunction with Exclusive package. ⁷ Option for AMG S-Models. ⁸ Standard for AMG models. ⁹ Standard for AMG S-Models. ¹⁰ Option for AMG models. ¹¹ Optionally available at no extra charge. ¹² Standard item, optional for AMG models. Additional individual designo upholstery options are available from your authorised Mercedes-Benz dealer.

Nappa leather/
Exclusive nappa leather

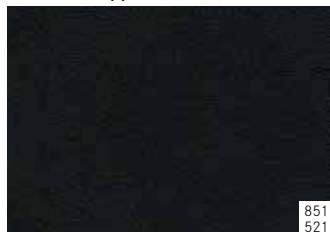

PASSION leather/
Exclusive PASSION leather

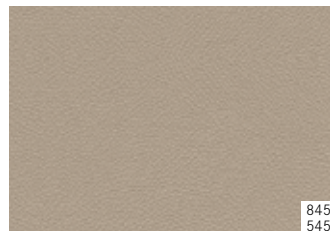
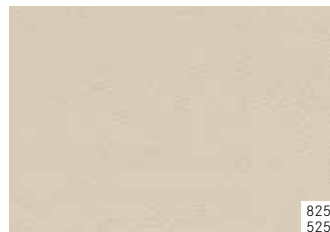
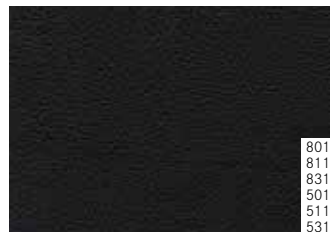

designo semi-aniline leather/
designo Exclusive semi-aniline leather

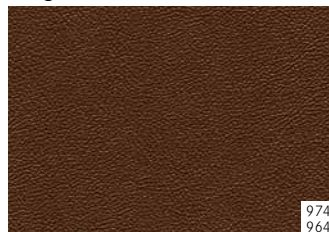

designo nappa leather¹⁰/
designo Exclusive nappa leather¹⁰



Trim

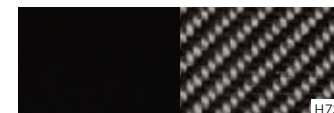

Paintwork.

Non-metallic paint



040

Metallic paints¹



183



796

designo paints¹



795

designo manufaktur paints¹



033



197



890



799



044



755



988



996

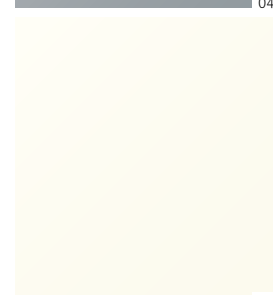

049

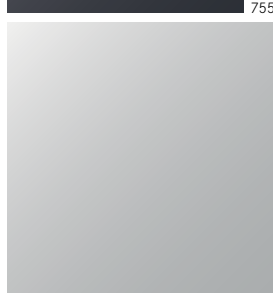

775

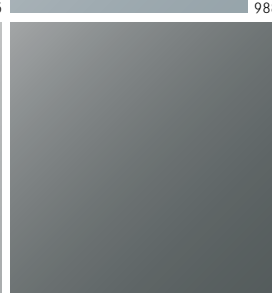

992

Non-metallic paint

040 black

Metallic paints¹

183 magnetite black

197 obsidian black

755 tenorite grey

775 iridium silver

796 citrine brown

890 cavansite blue

988 diamond silver

992 selenite grey

designo paints¹

795 designo manganite grey magno²

799 designo diamond white bright

996 designo hyacinth red metallic

designo manufaktur paints¹

033 designo mocha black metallic

044 designo allanite grey magno²

049 designo cashmere white magno²

¹ Optional extra. ² Matt paint finish.

Further individual designo paint finishes available from your authorised Mercedes-Benz dealer.



Mercedes-Benz is one of the founding partners of the “Laureus Sport for Good Foundation”.

Since the foundation was established in 2000, Mercedes-Benz has been supporting and promoting the aims and values of this worldwide non-profit-making programme: to use social sports projects to improve the lives of children and young people who are disadvantaged or suffering from illness. Laureus has become a fundamental element of Mercedes-Benz’s social responsibility. Every new Mercedes is an ambassador embodying these values. In buying a Mercedes you are supporting the “Laureus Sport for Good Foundation”.

Please note: changes may have been made to the product since going to print (06.08.2015). The manufacturer reserves the right during the delivery period to make changes to the design, form, colour or specification, provided these changes, while taking into account the interests of the vendor, can be deemed reasonable with respect to the purchaser. Where the vendor or the manufacturer uses symbols or numbers to describe an order or the subject of an order, no rights may be derived solely from these. The illustrations may include accessories and optional extras which do not form part of the standard specification. Actual colours may differ slightly from those shown owing to the limitations of the printing process. This brochure is distributed internationally. Information given regarding statutory regulations, legal requirements and taxation and the consequences thereof applies to the Federal Republic of Germany only and is correct at the time of going to press. For current and more specific information in relation to the range of models, features, optional extras, colours and/or services available in your country, and their pricing, you should contact your nearest authorised Mercedes-Benz Passenger Car Dealer.

www.mercedes-benz.com

Daimler AG, Mercedesstr. 137, 70327 Stuttgart MS/MAC 6701 · 0711 · 02-03/1215

Take-back of end-of-life vehicles. At the end of its life, we will be glad to take back your CLS for environment-friendly disposal in accordance with the end-of-life vehicle directive of the European Union (EU). But that day lies a long way off.

A network of vehicle take-back depots and dismantlers is available to make returning your vehicle as easy as possible for you. You are welcome to return your vehicle to one of these establishments free of charge. In so doing, you will be making a valuable contribution towards completing the recycling loop and preserving resources.

For further information about the recycling and disposal of end-of-life vehicles and take-back conditions, please visit your national Mercedes-Benz website.