

GENERAL

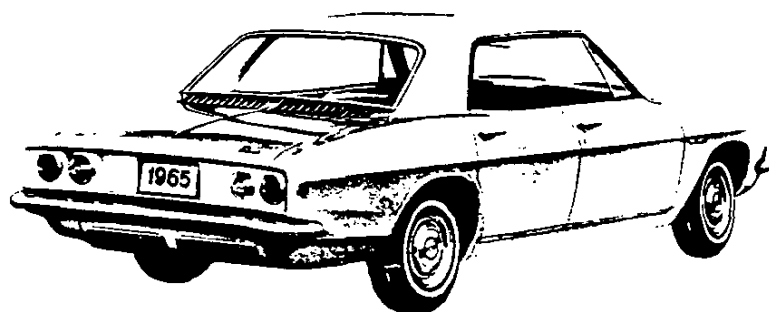

MODEL IDENTIFICATION	2
SERIAL NUMBERS AND IDENTIFICATION	3
REGULAR PRODUCTION EQUIPMENT - EXTERIOR	4
REGULAR PRODUCTION EQUIPMENT - INTERIOR	5
REGULAR PRODUCTION OPTIONS	6
DEALER INSTALLED ACCESSORIES	7

MODEL IDENTIFICATION

10100 CORVAIR 500

MODEL 10137 2-DOOR SPORT COUPE, 5-PASSENGER
MODEL 10139 4-DOOR SPORT SEDAN, 6-PASSENGER

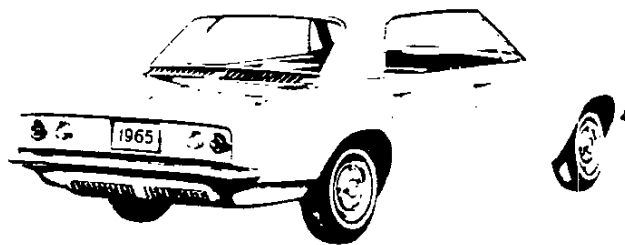

10500 MONZA

MODEL 10537 2-DOOR SPORT COUPE, 4-PASSENGER
MODEL 10539 4-DOOR SPORT SEDAN, 5-PASSENGER
MODEL 10567 2-DOOR CONVERTIBLE, 4-PASSENGER

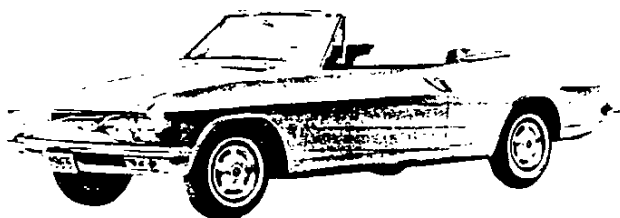

10700 CORSA

MODEL 10737 2-DOOR SPORT COUPE, 4-PASSENGER
MODEL 10767 2-DOOR CONVERTIBLE, 4-PASSENGER

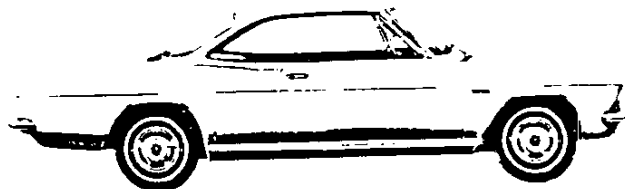

R1206 DELUXE GREENBRIER

MODEL R1206 6-DOOR SPORTS WAGON, 6-PASSENGER

SERIAL NUMBERS AND IDENTIFICATION

ONLY BASIC DESIGNATIONS SHOWN

VEHICLE SERIAL NUMBER

Example:

Model	1965	(Willow Run)	(25th unit)
10137	5	W	100025

Thus: The 25th model built at Willow Run would be serial number 101375W100025

REAR AXLE IDENTIFICATION

Example: RA 0212T

Source [†] Designation	Production* Month and Day	Type Designation
T(Tonawanda)	0212	RA

RA - 6-cylinder, 3 and 4-speed (101-10500)
 RB - 6-cylinder, 3-4 speed (10700)
 RG - 6-cylinder, automatic (101-10500)

* - Month: February, 02: 12th day of February, 12

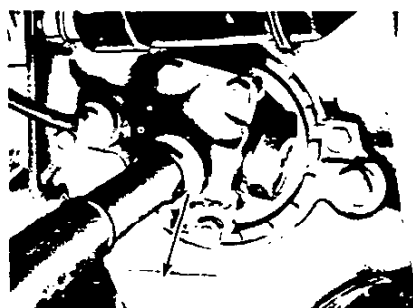

Starting unit number ----- 100001 and up at each assembly plant
 Location ----- On plate on L.H. rear top of side rail rearward of battery retaining unit

Location ----- Number stamped on lower left side of differential carrier

ASSEMBLY PLANTS
 W-Willow Run
 L-Los Angeles

ENGINE IDENTIFICATION

Example: AA0212B

Type Designation	Production* Month and Day	Source [†] Designation
AA	0212	W(Warren)

AA ----- 101-105-10700 3-speed, 4-speed ----- 3.27:1
 AE ----- 101-10500 Powerglide ----- 3.27:1

* - Month: June, 06: 12th day of June, 12
 † - G-Gear & Axle, B-Buffalo, W-Warren



Location ----- Stamped on top of crankcase at rear of engine rear center, right of generator

REGULAR EQUIPMENT—EXTERIOR

Bright Metal Trim & Moldings	Stainless Steel	Back window reveal	All exc. convs.
		Body belt - rear	Convertibles
		Roof drip gutter	10537,39; 10737
		Roof reveal	All exc. conv.
		Windshield header and pillar	Convertibles
	Anodized Aluminum	Windshield reveal	All
		Back-up lamp bezels	105-10700
		Back-up lamp cover plates	10100
		Body sill	105-10700
		Engine air exhaust grilles	10700
		Headlamp and taillamp bezels	All
		Parking lamp bezels	All
		Rear cove reveal	
		Wheel openings	105-10700
		Chrome Plated Metal	Engine compartment lid nameplate "Corvair"
	Engine compartment lid emblem "140"		10700
	Front compartment lid nameplate "Corvair"		
	Front panel emblem		All
	Front door vent glass channel and post		
	Front door vent glass frame		
	Front fender series nameplate		101-10700
	Front fender series emblem (Rr. cqr. emblem 10700)		105-10700
	Hub caps		10100
	Wheel trim covers		105-10700
	Back-up lamps		
	Body rear cove area (silver painted)	10700	
	Exhaust grille - engine air - (silver painted)	10500	
	Filler - left front fender gasoline	All	
	Horn - single	10100	
	Horns - dual	105-10700	
Lamp - rear license	All		
Top - counterbalanced manual folding	Convertible		
Wipers - dual electric single speed windshield	All		

REGULAR EQUIPMENT—INTERIOR

Bright Metal Trim and Moldings	Coat hooks		All exc. convs.	
	Console - transmission shift lever		10700	
	Door and window controls handles - single arm		All	
	Door sill plates		All	
	Front seat end panels			
	Rear view mirror back and support		105-10700	
	Seat adjuster handle			
	Sunshade supports		All	
	Transmission shift lever		10700	
Instrument Panel	Cigarette lighter and ash tray		All	
	Control knobs - chrome		All	
	Glove box door series nameplate		10700	
	Glove box door series emblem		10500	
	Glove box lock		All	
	Ignition lock and starter switch - "4-Position"		All	
	Instrument panel trim plates	Black paint	10700	
		Silver paint	10500	
	Instrument cluster - standard		101-10500	
	Instrument cluster (special)	Speedometer with trip odometer		10700
		Tachometer		
		Manifold pressure and cylinder head temperature gauge		
Electric clock				
Vent control knobs - color-keyed		All		
Interior Lights	Glove box lamp		105-10700	
	Instrument panel courtesy (dual)		Convertibles	
	Roof center dome		All exc. convs.	
Steering Wheel	Deep hub - dual solid spokes - horn button		10100	
	Deep hub - dual solid spokes - 2-tone horn ring		105-10700	
Armrests - front door		All		
Armrests with ashtrays - rear door or quarter panel		105-10739, 67		
Heater - perimeter		All		
Locking buttons - door		All		
Mat - luggage compartment		105-10700		
Mirror - rear view (painted back and support)		10100		
Seat belts - front		All		
Seat - folding rear		105-10700 exc. convs.		
Seats - front bucket		105-10700		
Sunshades - dual		All		
Switch - front door jamb		105-10700		
Switch - manual dome lamp (main switch)		All		
Ventipanes - friction pivot front		All		

REGULAR PRODUCTION OPTIONS

BODY OPTIONS

Name	Number	Models	
Air conditioning, All Weather	C64	101,10500	
Antenna, radio rear manual	U73	All	
Armrests, rear door	D10	10139	
Comfort and Convenience	Lamp, glove box	Z01	
	Lamp, back-up		
	Mirror, inside & outside rear view		
	Wiper and washer, 2-speed W/S		
	Mirror, remote control outside	Z13	
Glass, tinted	A01	All	
Glass, tinted windshield	A02		
Guard, front bumper	V31		
Guard, rear bumper	V32		
Heater (delete)	C48		
Lock, spare wheel	P19		
Pad, instrument panel	B70		
Radio and antenna, manual tuning	U60		
Radio and antenna, push button tuning	U63		
Radio and antenna, AM-FM push button tuning	U69		
Seat belts, custom deluxe front (with retractors)	A49		
Seat belts, custom deluxe rear	A47		
Seat belts, custom rear	A64		
Seat belts, (delete)	A62		
Seat, folding rear	A67		10100
Speaker, radio auxiliary	U80		All exc. convs.
Steering, telescoping shaft	N36		All
Top, convertible electric folding	C06	105,10767	
Top, convertible folding (color options)	C05		

ENGINE OPTIONS

Air cleaner, heavy duty pre-cleaner	K46	101,10500
Air cleaner, oil bath	K47	All
Generator, Delcotron 12-47 amp.	K84	
164 Cubic Inch P-6 110 HP	L62	101,10500
164 Cubic Inch P-6 140 HP	L63	
164 Cubic Inch P-6 180 HP Turbocharged	L87	10700

CHASSIS OPTIONS

Axle, rear (3.27:1 ratio)	G93	All
Axle, rear (3.55:1 ratio)	G95	101,10500
Axle, rear limited slip (3.27:1 or 3.55:1 ratio)	G81	All
Battery, heavy duty	T60	
Cover, simulated wire wheel	P02	10100
Cover, wheel trim	P01	
Steering wheel, wood grained plastic	N34	All
Tires, 6.50 x 13-4 pr whitewall rayon	P53	

TRANSMISSION OPTIONS

Four speed transmission	M20	All
Powerglide transmission	M35	101,10500

DEALER INSTALLED ACCESSORIES

Air conditioning, All Weather	101,10500
Antenna, radio front manual	All
Antenna, radio rear manual	
Cap, gas tank filler locking	All except 10700
Clock, instrument panel	
Compass, auto	All
Container, floor litter (saddle type)	All exc. floor shift transmission
Cover, simulated wire wheel trim	All
Cover, simulated magnesium wheel	
Cover, wheel trim	10100
Fire extinguisher, 2-3/4 & 5 lb dry chemical	All
Frame, license plate	
Guard, front bumper	
Guard, door edge	
Guard, gas tank filler door	
Guard, rear bumper	
Lamp, ash tray	
Lamp, back up	
Lamp, courtesy	All except convertible
Lamp, glove box	10100
Lamp, luggage compartment	All
Lamp, parking brake alarm	
Lamp, portable spot	
Lamp, underhood	
Lock, spare wheel	
Lock, rear door safety	All 4-door models
Luggage carrier, deck lid	All
Mat, contour twin front floor	
Mat, contour twin rear floor	
Mat, full width front floor	
Mat, full width rear floor	
Mirror, inside rear view prismatic	
Mirror, outside rear view	
Mirror, remote operated outside rear view	
Mirror, visor vanity	All except convertible
Molding, body sill	10100
Rack, rear deck luggage	105-10767
Radio and antenna, AM-FM push button tuning	All
Radio and antenna, manual tuning	
Radio and antenna, push button tuning	
Radio speaker, rear auxiliary	
Radio stereo equipment	All except convertible
Seat cushion, ventilated	All
Seat belts, Custom Deluxe	
Seat belts, Custom rear	
Seat belt retractors	
Switch, traffic hazard lamp	
Tissue dispenser (saddle type)	
Tissue dispenser, instrument panel	
Tool kit	
Trailer hitch, 1000 pound capacity	
Windshield washer, single speed wiper	
Wiring harness, car to trailer connecting	

DEALER INSTALLED ACCESSORIES

Air conditioning, All Weather	101,10500
Antenna, radio front manual	
Antenna, radio rear manual	All
Cap, gas tank filler locking	
Clock, instrument panel	All except 10700
Compass, auto	All
Container, floor litter (saddle type)	All exc. floor shift transmission
Cover, simulated wire wheel trim	All
Cover, simulated magnesium wheel	
Cover, wheel trim	10100
Fire extinguisher, 5 pound dry chemical	
Frame, license plate	
Guard, front bumper	
Guard, door edge	All
Guard, gas tank filler door	
Guard, rear bumper	
Lamp, ash tray	
Lamp, back up	10100
Lamp, courtesy	All except convertible
Lamp, glove box	10100
Lamp, luggage compartment	
Lamp, parking brake alarm	
Lamp, portable spot	All
Lamp, underhood	
Lock, rear door safety	All 4-door models
Mat, contour twin front floor	
Mat, contour twin rear floor	
Mat, full width front floor	
Mat, full width rear floor	All
Mirror, inside rear view prismatic	
Mirror, outside rear view	
Mirror, remote operated outside rear view	
Mirror, visor vanity	All except convertible
Molding, body sill	10100
Rack, rear deck luggage	105-10767
Radio and antenna, AM-FM push button tuning	
Radio and antenna, manual tuning	
Radio and antenna, push button tuning	All
Radio speaker, rear auxiliary	
Radio stereo equipment	All exc. convs.
Seat belts, Custom Deluxe	
Seat belt retractors	
Switch, traffic hazard lamp	
Tissue dispenser (saddle type)	
Tissue dispenser, instrument panel	All
Tool kit	
Trailer hitch, 1000 pound capacity	
Windshield washer, single speed wiper	
Wiring harness, car to trailer connecting	

GREENBRIER REGULAR PRODUCTION OPTIONS

BODY OPTIONS

Bumper, front and rear chrome	V37	R1206	
Cover, wheel trim	P01		
Custom Equipment	Anodized aluminum dispatch box trim plate		Z60
	Chrome plated front and rear bumpers		
	Chrome plated hub caps		
	Chrome cigarette lighter		
	Front and Rear dome lamp		
	Rear door red cove inserts		
	Right hand sunshade		
	Stainless steel windshield reveal moldings		
	Spare tire cover, vinyl		
	Special roof panel paint treatment		
	LH & RH armrest for front compartment		
	Front seat backrest rear compartment ash tray		
	Two-tone steering wheel		
Vinyl seat trim			
Vinyl coated rubber floor covering			
Vinyl trim pads (doors and sidewalls)			
Four interior colors keyed to exterior color			
3/4 inch foam pad for seat backrest			
Door, body side, LH	E85		
Glass, laminated	A09		
Heater, direct air	C40		
Heater, gasoline	C45		
Mirror, rear view (outside)	D32		
Mirror, rear view (outside West Coast type)	D29		
Radio and antenna, manual tuning	U60		
Seat belts, Custom Deluxe (with retractors)	A49		
Seat belts (delete)	A62		
Seat, supplementary (includes LH & RH rear armrest)	A59		
Switch, hazard warning	V74		
Wiper and washer, 2-speed w/s	C14		

ENGINE OPTIONS

Air cleaner, oil bath	K47	R1206
Generator, Delcotron 12-42 amp	K79	
164 cubic inch P6 180 HP	L62	

CHASSIS OPTIONS

Axle, rear limited slip	G81	R1206	
Tires	7.35 x 14-4PR blackwall rayon		R21
	7.35 x 14-4PR whitewall rayon		R20
	7.35 x 14-6PR blackwall rayon		R24
	7.35 x 14-6PR whitewall rayon		R22
	7.35 x 14-8PR blackwall rayon		R25
Spring, heavy duty front	F60		

TRANSMISSION OPTIONS

Four speed transmission	M20	R1206
Powerglide transmission	M35	

GREENBRIER DEALER INSTALLED ACCESSORIES

Antenna, radio front	
Arm rest	
Camper unit	
Cap, gas tank filler locking	
Carrier, roof luggage	
Clock, instrument panel	
Compass, auto	
Container, litter (saddle type)	
Cover, roof luggage carrier	
Cover, simulated wire wheel	
Cover, wheel trim	
Fire extinguisher, 2-3/4 pound dry chemical	
Guard, bumper (painted)	
Guard, bumper (chrome plate)	
Heater, gasoline	
Heater, direct air	
Heater, direct air (ICC)	
Lamp, courtesy	
Lamp, dome	
Lamp, glove box	
Lamp, portable spot	
Lamp, straight shaft spot	
Lighter, cigarette	
Mirror, inside rear view prismatic	
Mirror, outside rear view	
Mirror, outside West Coast Junior	
Radio and antenna, manual tuning	
Rain deflectors	
Seat belt, custom deluxe	
Seat belt retractor	
Screens, window	
Signal, direction (Class A)	
Sleeper, ladder and car top	
Switch, traffic hazard lamp	
Table, 2 ft x 4 ft	
Tent, pop-up	
Tissue dispenser, instrument panel	
Visor, right hand sun	
Windshield washer, single speed wiper	
Wiring harness, heater and radio accessory	

R1206

ORIGINAL COPY

DIMENSIONS AND WEIGHTS

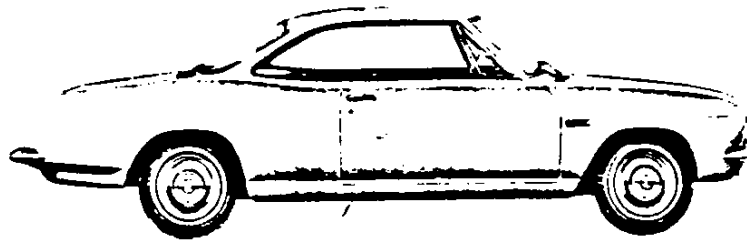

INTERIOR DIMENSIONS	2
EXTERIOR DIMENSIONS	4
SEDAN TRUNK SPACE	6
VEHICLE WEIGHTS	7

INTERIOR DIMENSIONS.

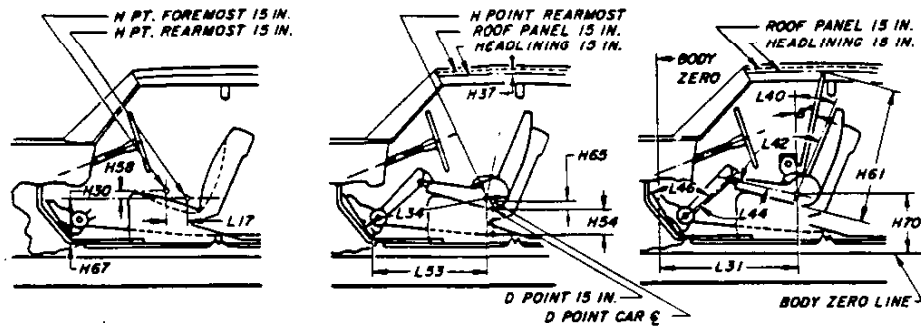

FRONT COMPARTMENT	CODE	DESCRIPTION	Sport Coupe		Convertible	Sport Sedan	
			Bench	Bucket	Bucket	Bench	Bucket
	L31	Body zero line to H point	43.0		42.7	43.0	42.7
	H5	H point to ground	16.8		16.9	15.8	16.9
	H61	Effective head room	37.5	37.7	38.5		37.6
	H37	Headlining to roof height	.6	.5	.0		.5
	L34	Maximum effective leg room - accelerator	41.1		40.9	41.1	40.9
	H30	H point to heel point	7.6		7.4		7.4
	H67	Depressed floor covering thickness			.5		
	L40	Back angle	24°		25°	24°	25°
	L42	Hip angle			92°		
	L44	Knee angle	123°		122°	123°	122°
	L46	Foot angle	79°		78°		
	H65	H point differential, side to center	.1		---	.2	---
	H54	H point to tunnel	4.7		---	4.6	---
	L53	H point to accelerator floor point	34.0		33.9	34.0	33.9
	L17	H point travel			4.0		
	H58	H point rise			.5		

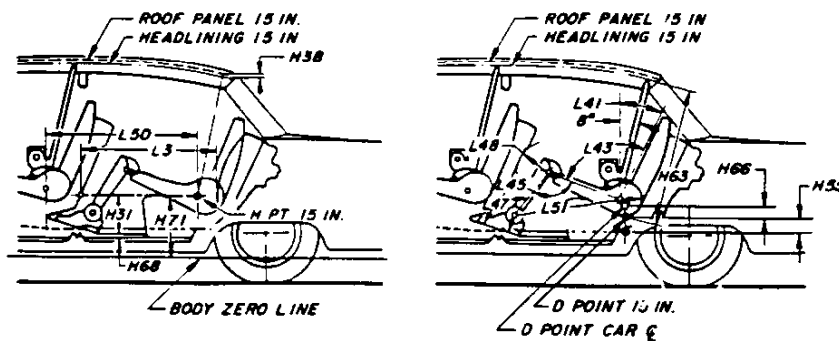

REAR COMPARTMENT	CODE	DESCRIPTION	Sport Coupe		Convertible	Sport Sedan	
			Bench	Bucket	Bucket	Bench	Bucket
	L50	H point couple distance		28.6	28.8	32.0	32.2
	H10	H point to ground	15.3		15.1	16.6	16.4
	H63	Effective head room		36.4	38.2	36.4	36.6
	H38	Headlining to roof height		.2	.0		.6
	L51	Minimum effective leg room	30.8	30.5	30.8	35.4	34.6
	H31	H point to heel point	8.8		9.0	10.3	10.2
	H68	Depressed floor covering thickness	.4	.2	.2	.3	.2
	L48	Minimum knee room	1.1	.7	.8	3.1	3.0
	L3	Rear compartment room	23.8	23.2	23.8	26.6	26.0
	L41	Back angle	23°	21°	19°	27°	21°
	L43	Hip angle	73°	72°	70°	87°	79°
	L45	Knee angle	76°	78°	80°	92°	88°
	L47	Foot angle	114°		113°	121°	120°
	H66	H point differential, side to center	.0		.2	.5	.2
	H55	H point to tunnel		2.0	1.8		3.3

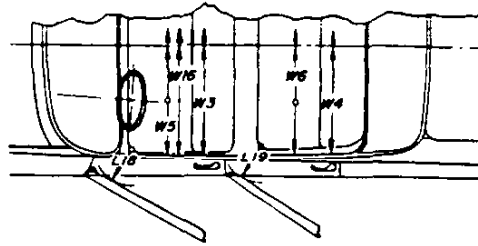
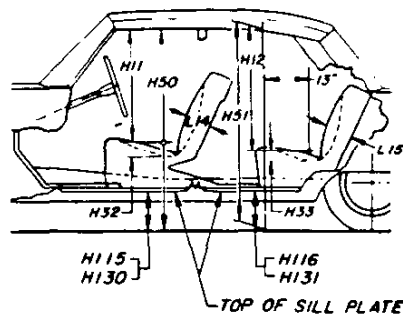

SEAT AND ENTRANCE	FRONT	CODE	DESCRIPTION	Sport Coupe		Convertible	Sport Sedan	
				Bench	Bucket	Bucket	Bench	Bucket
				W1	Hat room	51.0		
W3	Shoulder room			54.7				
W5	Hip room			56.1				
W1b	Seat width	53.0		51.7		50.7	51.7	
H3	Seat chair height	10.0		9.9		10.0	9.9	
H50	Upper body opening to ground	41.0			46.9			
H11	Entrance height	30.0	30.1	30.0		30.1		
L18	Entrance - foot clearance	13.7		13.6		12.8	13.6	
H32	Seat cushion deflection	3.6		4.0		3.8	4.0	
L14	Thickest point of seat back, at C/LO	6.0		6.4		5.9	6.4	
H2b	Interior body height - at car C/L	43.4				43.3		
H27	Interior body height - at C/LO	43.0	43.1	43.3			43.0	
W2	Hat room		48.5		47.4	45.7	46.4	
W4	Shoulder room		52.7		47.9		54.3	
W6	Hip room		54.8		48.2		56.1	
H8	Seat chair height	9.8		9.9		11.6	11.7	
H51	Upper body opening to ground						46.7	
H12	Entrance height					30.0	30.2	
H60	Exit height					29.2	29.4	
L19	Entrance - foot clearance	10.7		9.4			12.0	
H33	Seat cushion deflection	4.2	4.3	4.2		3.2	3.4	
L15	Thickest point of seat back, at C/LO	5.8	6.2	6.3			5.8	
H28	Interior body height - at car C/L	39.8	39.9	41.1			41.7	
H29	Interior body height - at C/LO	39.2	39.3	40.8			41.3	

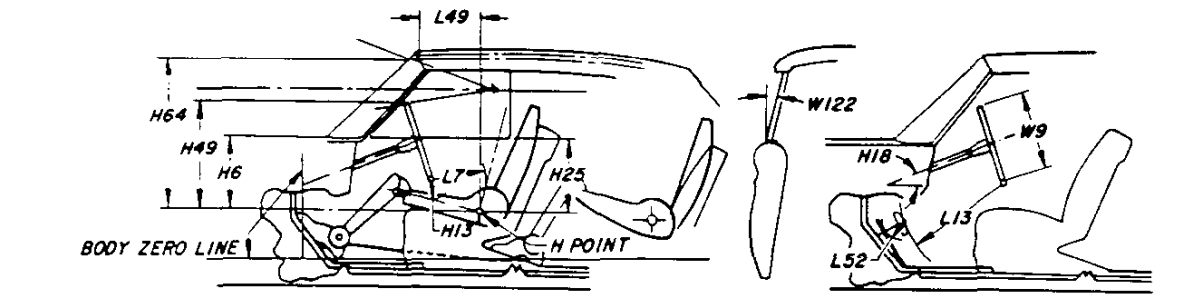

VISION	FRONT	CODE	DESCRIPTION	Sport Coupe		Convertible	Sport Sedan	
				Bench	Bucket	Bucket	Bench	Bucket
				Hc	H point to windshield bottom	19.2		
Hc4	H point to windshield upper DLO	30.4			30.5			
L49	H point to windshield upper DLO		12.1		12.0		12.1	
H25	Belt height - front	17.0			17.7			
W	Steering wheel center to C/L of car				14.0			
W0	Steering wheel outside diameter				16.0			
H15	Steering column angle - horizontal				20°			
H40	H point to top of steering wheel	22.6			22.7			
L	Steering wheel torso clearance	12.1			12.0			
H1	Steering wheel thigh clearance	3.1		3.0		3.1	3.0	
L1	Brake pedal knee clearance				23.9			
L52	Brake pedal to accelerator				2.0			
W122	Stumble - home				22°			

EXTERIOR DIMENSIONS.

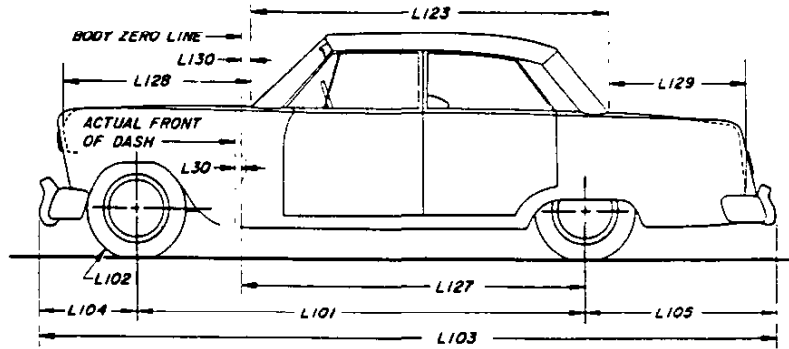

L E N G T H S	CODE	DESCRIPTION	Sport Sedans	Sport Coupes	Convertibles
	L30	Body O line to actual front of dash		.0	
	L101	Wheelbase		108.0	
	L104	Overhang, front		33.0	
	L105	Overhang, rear		42.3	
	L103	Overall length		183.3	
	L128	Hood length at centerline		43.3	
	L123	Body upper structure length at car centerline	93.9	91.9	89.1
	L129	Deck length at centerline	32.3	34.3	37.2
	L127	Body O line to centerline of rear wheels		98.0	
L130	Body O line to windshield cowl point		10.8		
L102	Tire size		6.50 x 13		
	Overall length - less bumpers		179.7		

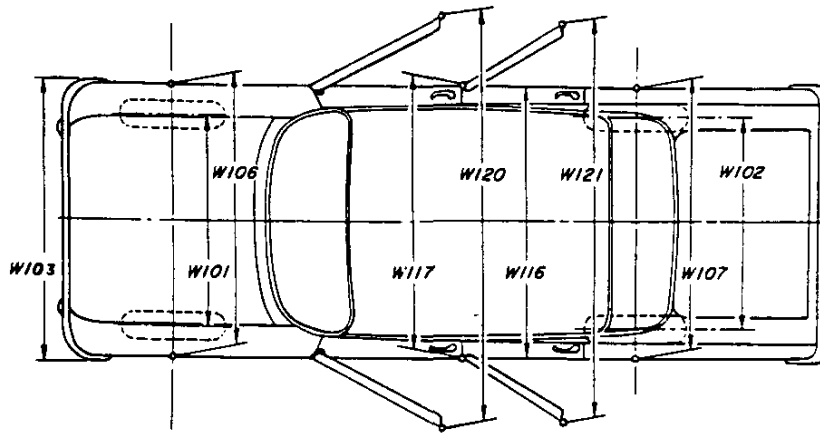

W I D T H S	CODE	DESCRIPTION	Sport Sedans	Sport Coupes	Convertibles
	W101	Tread - front		55.0	
	W102	Tread - rear		57.2	
	W103	Maximum overall width of car		69.7	
	W116	Maximum overall width of body		69.7	
	W117	Maximum body width at #2 pillar	69.3		---
	W106	Front fender overall width		69.3	
	W107	Rear fender overall width		69.7	
	W120	Maximum overall width, front doors open	131.3		149.4
	W121	Maximum overall width, rear doors open	127.7		---

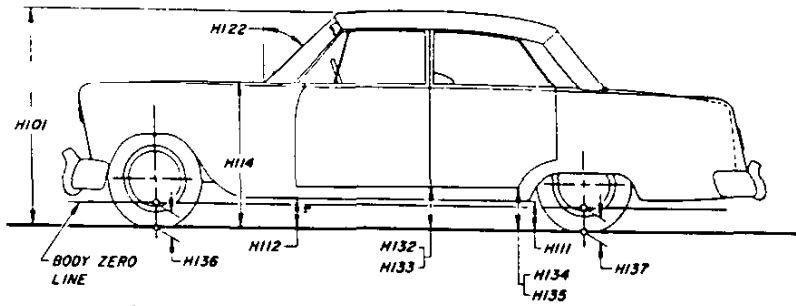

HEIGHTS	CODE	DESCRIPTION	Sport Sedans	Sport Coupes	Convertibles
	H101	Overall height (Design)	51.2	51.3	51.5
	H114	Hood at rear to ground		35.2	
	H112	Rocker panel to ground - front		6.8	
	H111	Rocker panel to ground - rear		6.4	
	H115	Step height - front (Design)		12.5	
	H110	Step height - rear (Design)	12.3		---
	H130	Step height - front (Curb)		14.0	
	H131	Step height - rear (Curb)	13.8		---
	H132	Bottom of door to ground, open - front		10.9	
H133	Bottom of door to ground, closed - front		10.6		
H134	Bottom of door to ground, open - rear	10.2		---	
H135	Bottom of door to ground, closed - rear	10.4		---	
H102	Front bumper to ground		16.4		
H104	Rear bumper to ground		16.6		
H122	Windshield slope angle		53°		
H136	Body O line to ground - front		5.0		
H137	Body O line to ground - rear		5.0		
H125	Headlamp to ground		23.0		
H126	Taillamp to ground		23.5		
H158	Roof thickness		3.6		
H159	DLO height		12.0		
H160	Body thickness		27.5		
H301	Lift over height		27.6		
	Overall height (Curb)	52.7	52.8	53.0	

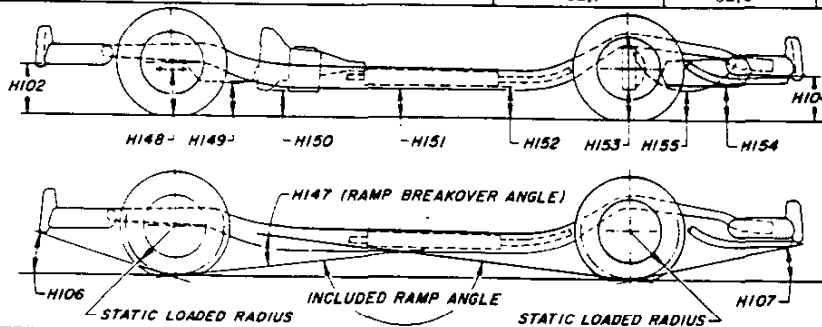

CLEARANCES	CODE	DESCRIPTION	Sport Sedans	Sport Coupes	Convertibles
	H100	Angle of approach		26°	
	H107	Angle of departure		20°	
	H147	Ramp breakover angle		11°	
	H148	Front suspension to ground		5.9	
	H149	Oil pan to ground		5.9	
	H150	Flywheel housing to ground		5.6	
	H151	Frame to ground		6.4	
	H152	Exhaust system to ground		7.5	
	H153	Rear axle to ground		8.8	
H154	Fuel tank to ground		6.8		
H155	Tire well to ground		---		
H150	Minimum ground clearance		5.4		

SEDAN TRUNK SPACE

TRUNK CAPACITIES (CU. FT.)

Model	Location	Overall	Standard Luggage
All	Front compartment	13.3	7.0
	Rear seat well (exc. 105-10767)		
	Rear compartment (inc. seat well and folding seat down) (exc. 105-10767)		
	Total capacity		

* on models 105-10767.

VEHICLE WEIGHTS

10100 CORVAIR 500

VEHICLE TYPE		SHIPPING WEIGHT			CURB WEIGHT			DESIGN WEIGHT †		
Model	Description	Front	Rear	Total	Front	Rear	Total	Front	Rear	Total
10137	2-Door Sport Coupe 6-cylinder	835	1550	2385	915	1555	2470	1140	1930	3070
10137P		835	1560	2395	915	1565	2480	1140	1940	3080
10139	4-Door Sport Sedan 6-cylinder	815	1590	2405	900	1595	2495	1115	1980	3095
10139P		815	1600	2415	900	1600	2500	1115	1985	3100

10500 MONZA

10537	2-Door Sport Coupe 6-cylinder	855	1585	2440	935	1595	2530	1160	1970	3130
10537P		855	1595	2450	935	1600	2535	1160	1975	3135
10539	4-Door Sport Sedan 6-cylinder	840	1625	2465	920	1630	2550	1130	2020	3150
19539P		840	1635	2475	920	1640	2560	1130	2030	3160
10567	2-Door Convertible 6-cylinder	940	1735	2675	1020	1740	2760	1240	2120	3360
10567P		940	1740	2680	1020	1750	2770	1240	2130	3370

10700 CORSA

10737	2-Door Sport Coupe 6-cylinder	870	1605	2475	950	1610	2560	1175	1985	3160
10737P		870	1615	2485	950	1620	2570	1175	1995	3170
10767	2-Door Convertible 6-cylinder	950	1760	2710	1030	1775	2805	1250	2155	3405
10767P		950	1770	2720	1030	1785	2815	1250	2165	3415

P - Powerglide

SHIPPING WEIGHT: The weight of the basic vehicle with all regular equipment and with grease and oil where required. It does not include the weight of gasoline.

DESIGN WEIGHT: The curb weight of the basic vehicle plus 150 pounds for each passenger.

Example:

Model 10737 (4-passengers, 2 front, 2 rear)

---- 2560 + 600 = 3160

CURB WEIGHT: The weight of the empty vehicle ready to drive. It is the shipping weight plus the weight of gasoline. For the weight of gasoline add 80 pounds.

PERFORMANCE WEIGHT: The curb weight of the lowest priced 4-door sport sedan with regular equipment plus 600 pounds for 4-passengers.

Example:

Model 10139 (6-passengers) ---- 2495 + 600 = 3095

† - Based on passenger weight distribution of number of passengers in front and rear. For total loaded weight, add 150 lbs. for each passenger in the designated passenger carrying capacity for the particular vehicle.

BODY

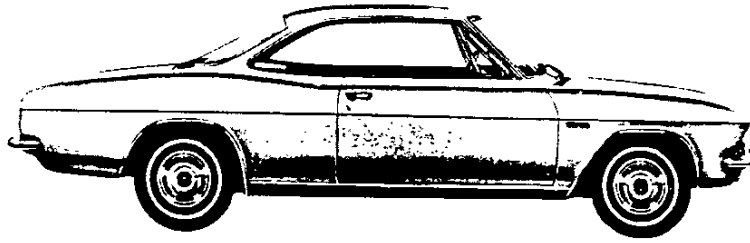

EXTERIOR PAINT PROCESS	2
EXTERIOR-INTERIOR COLOR COMBINATIONS	3
BODY GLASS	5
BODY CONSTRUCTION	6

EXTERIOR PAINT PROCESS



1. **RUSTPROOFING . . .** Bare steel is thoroughly treated with chemicals that etch the metal for improved paint adhesion. This chemical also cleans the metal to give it a corrosion-resisting surface.
2. **BODY AND SHEET METAL PRIMER . . .** Four different and specially formulated corrosion resistant primers are used during sub-assembly of the body where rust could possibly develop. Areas considered especially critical are subsequently coated with another type rust inhibiting compound, after the lacquer coats have been applied.
A primer coat is applied to all outside and inside surfaces of the front fenders and hood. This is done by dipping or flowcoating to insure coating in all seams and secluded areas, and then baking at 390 degrees F for 30 minutes. After baking, a coat of sealer is applied to all surfaces requiring a subsequent coat of lacquer.
3. **PRIMER-SURFACER COAT AND FLASH PRIME COAT . . .** An air dried flash prime coat is applied to surfaces below the beltline. Next, a full primer-surfacer coat is applied to all outside surfaces of the body, receiving lacquer and then oven baked for 45 minutes at 285 degrees F.
4. **SANDING . . .** Power wet sanding followed by hand sanding is done on all surfaces requiring lacquer.

Upon inspection, spot sanding assures an absolutely smooth surface for the lacquer. After lacquer application and initial baking, final wet sanding, both power and hand, prepares the body for final baking by removing surface irregularities.

5. **LACQUERING . . .** Many coats of acrylic lacquer are now sprayed on the surfaces to build up a finish of the required thickness for each color.
6. **INITIAL BAKING . . .** To set up the paint hardness for final sanding the body is baked for approximately 10 minutes at 200 degrees F.
7. **FINAL BAKING . . .** To assure a durable, hard, high luster finish the lacquer is now baked for 30 minutes at 275 degrees F. Reheating the lacquer after final sanding permits paint film to soften and allows surface blemishes and sanding scratches to disappear during the thermo-reflow process.
8. **UNDERCOATING . . .** An asphaltic based-asbestos fiber type sound deadener is sprayed inside the wheel housings and on the underside of the underbody at designated locations to block out road noises.
9. **PAINT REPAIR . . .** Any slight mars, nicks, or scratches that might occur during final assembly are factory-repaired and corrected before shipment. Light "slush" polishing is done to bring painted surfaces to a high luster finish. Wax is sprayed on each vehicle for protection during transit.

EXTERIOR—INTERIOR COLOR COMBINATIONS

10100 CORVAIR 500

EXTERIOR			INTERIOR TRIM COLORS AND RPO NUMBERS		
			Fawn	Aqua	Red
RPO	Color	Sales Name	Models 10137-39		
			771	723	782
AA	Black	Tuxedo Black	X	X	X
CC	White	Ermine White	X	X	X
DD	Med. Blue	Mist Blue	X		
EE	Dk. Blue	Danube Blue	X		
HH	Med. Green	Willow Green	X		
JJ	Dk. Green	Cypress Green	X		
KK	Med. Aqua	Artesian Turquoise	X	X	
LL	Dk. Aqua	Tahitian Turquoise	X	X	
NN	Maroon	Madeira Maroon	X		X
PP	Orchid	Evening Orchid		Not Available	
RR	Red	Regal Red	X		X
SS	Saddle	Sierra Tan	X		
VV	Beige	Cameo Beige	X		X
WW	Slate	Glacier Gray		Not Available	
YY	Yellow	Crocus Yellow		Not Available	
Two-Tone (Lower/Upper) (a)					
CK	White/Med. Aqua			X	
DC	Med. Blue/White			Not Available	
HC	Med. Green/White			Not Available	
JV	Dk. Green/Beige		X		
LK	Dk. Aqua/Med. Aqua			X	
SV	Saddle/Beige		X		
VN	Beige/Maroon		X		
WA	Slate/Black			Not Available	
YC	Yellow/White			Not Available	

(a) Model 10139 only.

EXTERIOR—INTERIOR COLOR COMBINATIONS—CONT'D

10500 MONZA

10700 CORSA

EXTERIOR			INTERIOR TRIM COLORS AND RPO NUMBERS							
			Fawn	Red	Blue	Saddle	Black	Slate	White	White
RPO	Color	Sales Name	Models 10537-39-67, 10737-67 (a)							
			773	785	733	706	713	795	797(b)	798(c)
AA	Black	Tuxedo Black	X	X	X	X	X	X	X	X
CC	White	Ermine White	X	X	X	X	X	X	X	X
DD	Med. Blue	Mist Blue	X		X		X			X
EE	Dk. Blue	Danube Blue	X		X			X		
HH	Med. Green	Willow Green	X				X			X
JJ	Dk. Green	Cypress Green	X			X	X			
KK	Med. Aqua	Artesia Turquoise	X				X		X	X
LL	Dk. Aqua	Tahiti Turquoise	X						X	
NN	Maroon	Madeira Maroon	X	X		X	X			X
PP	Orchid	Evening Orchid					X			X
RR	Red	Regal Red	X	X			X			X
SS	Saddle	Sierra Tan	X			X	X			
VV	Beige	Cameo Beige	X	X		X	X			
WW	Slate	Glacier Gray					X	X		X
YY	Yellow	Crocus Yellow					X			X
Two-Tone (Lower/Upper) (d)										
CK	White/Med. Aqua								X	
DC	Med. Blue/White				X					
HC	Med. Green/White								Not Available	
JV	Dk. Green/Beige		X			X				
LK	Dk. Aqua/Med. Aqua								X	
SV	Saddle/Beige		X			X				
VN	Beige/Maroon		X							
WA	Slate/Black						X	X		
YC	Yellow/White						X			

Convertible top: White, black or beige with any exterior color.

(a) Not available for Model 10539.

Carpet and instrument panel are (b) aqua (c) black.

(d) Model 10539 only.

BODY GLASS

WINDOW ACTION

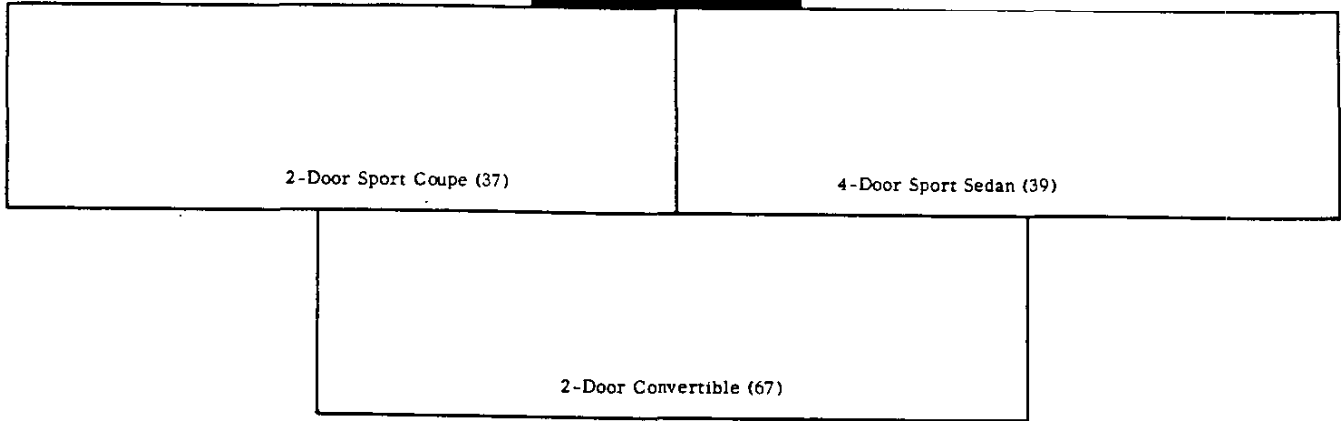

- P - Pivoting - friction type
- Z - Zip-Out
- Rotating (Rocker action)
- Rotating (67)

BODY GLASS TYPE AND VISIBILITY AREA

LOCATION		37	39	67
Windshield			1009.1	
Front Door Window	Pivoting Ventipane		51.6	
	Roll Down	821.1	606.0	821.1
Rear Door Window	Roll Down		726.8	
Rear Quarter Window	Roll Down	443.9		865.0
Back Window	One-Piece	1224.7	814.4	1056.0
Total Visibility (Sq In.)		3550.4	3207.0	2991.0

All window glass is curved safety solid plate except curved laminated safety plate windshield and flat plastic convertible rear window.

BODY CONSTRUCTION

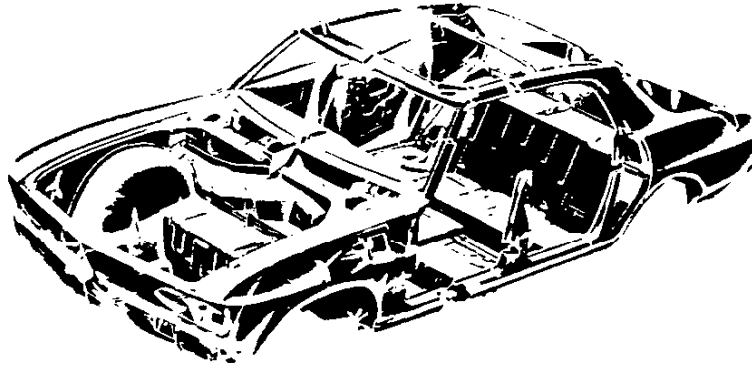

GENERAL

Type ----- Integral, with step-down underbody floor, front and rear side rail type members, front and rear end sheet metal components welded to the body assembly, and protective inner tender skirts.

DOORS AND LOCKS

Door construction (front and rear) ----- Two full steel welded panels hinged at front
Door handles ----- Push-button with fork type door latches. Inside push button locks on all doors.
Door ventipanes ----- Friction type

VENTILATION

High level with double wall plenum chamber, providing washing and air drying of rocker panels for corrosion resistance. Air and water travel through rocker panels and drain at ends of rocker inner panels.

HOOD AND DECK LID

Type ----- Dual panel construction, torsion rod counterbalanced luggage compartment lid with external keylock release, telescoping link engine compartment lid with external release lever. Engine compartment air intake beneath rear window providing plenum chamber arrangement with air to engine compartment and water separation and drain off.

WINDSHIELD WIPERS

Type ----- Positive action single speed electric
Linkage ----- Parallel acting

SEAT CONSTRUCTION

Type ----- Front seat cushion
0.75 poly foam ----- 10100
1.50 foam rubber ----- 105-10700
----- Rear seat cushion
Jute and cotton ----- 10100,
10537,67,10700
1.75 poly foam ----- 10539

SPARE TIRE MOUNT

Location ----- Right rear corner in engine compartment. Tools consist of scissors jack and combination wheel nut wrench and lever handle stored under tire.

BODY CONSTRUCTION

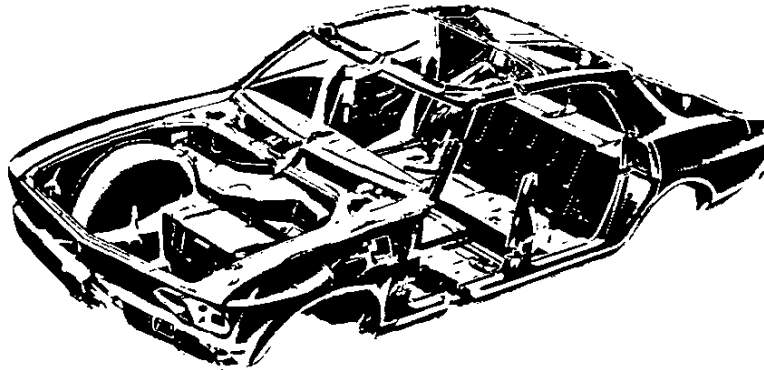

GENERAL

Type ----- Integral, with step-down underbody floor, front and rear side rail type members, front and rear end sheet metal components welded to the body assembly, and protective inner fender skirts.

DOORS AND LOCKS

Door construction (front and rear) ----- Two full steel welded panels hinged at front

Door handles ----- Push-button with fork type door latches. Inside push button locks on all doors.

Door ventipanes ----- Friction type

VENTILATION

High level with double wall plenum chamber, providing washing and air drying of rocker panels for corrosion resistance. Air and water travel through rocker panels and drain at ends of rocker inner panels.

HOOD AND DECK LID

Type ----- Dual panel construction, torsion rod counterbalanced luggage compartment lid with external keylock release, telescoping link engine compartment lid with external release lever. Engine compartment air intake beneath rear window providing plenum chamber arrangement with air to engine compartment and water separation and drain off.

WINDSHIELD WIPERS

Type ----- Positive action
single speed electric

Linkage ----- Parallel acting

SEAT CONSTRUCTION

Type ----- Front seat cushion
0.75 poly foam ----- 10100
1.50 foam rubber ----- 105-10700

----- Rear seat cushion
Jute and cotton ----- 10100,
10537,67,10700
1.75 poly foam ----- 10539

SPARE TIRE MOUNT

Location ----- Right rear corner in engine compartment. Tools consist of scissors jack and combination wheel nut wrench and lever handle stored under tire.

CHASSIS

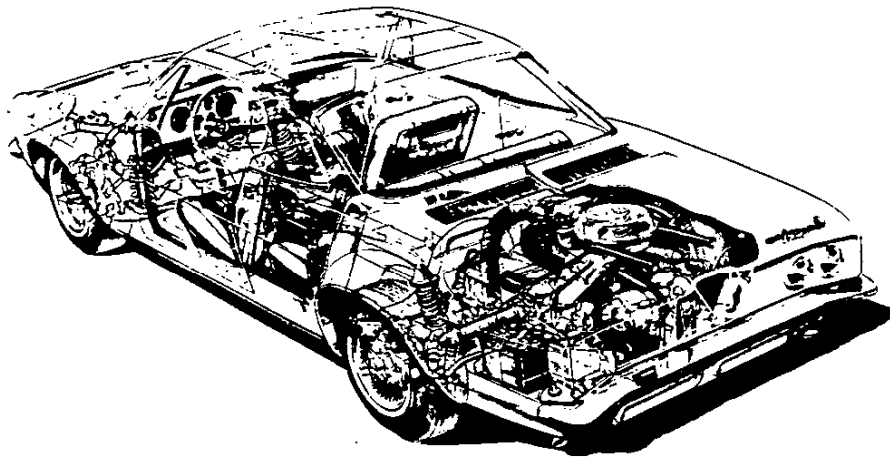

FRONT SUSPENSION	2
STEERING	3
REAR SUSPENSION	4
REAR AXLE	5
BRAKES	7
WHEELS AND TIRES	7
BULBS, FUSES, AND CIRCUIT BREAKERS	8

FRONT SUSPENSION

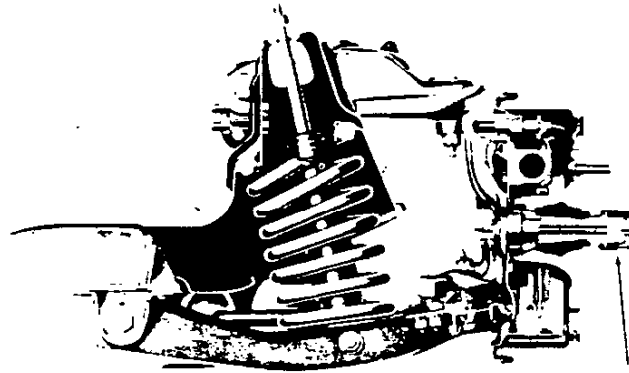

SPEEDOMETER
TAKE-OFF

LEFT FRONT

GENERAL

Description	Independent, SLA type, with coil spring and concentric shock absorber, and spherically-jointed steering knuckle, for each wheel. Adjustments to front suspension achieved with shims at upper control arm pivot shafts. Front suspension, front crossmember and steering linkage unitized as sub-assembly.
Wheel travel, from design height	
Total	7.19
Jounce	3.75
Rebound	3.44
Wheel to spring ratio	1.63

CONTROL ARMS

Description	
Upper	Stamped A frame with pre-loaded, steel encased rubber bushings at pivot
Lower	Strut-supported, stamped frame with pre-loaded, steel encased rubber bushings at pivot

STEERING KNUCKLE

Description	Forged steel with integral brake cylinder mounting, and detachable steering knuckle arm
Spindle	
Diameters	
At inner bearing	1.2493-1.2498
At outer bearing	.7492-.7497
Thread size	3/4-20 NEF-3 (modified)

WHEEL BEARINGS

Type	Taper roller
Quantity	Two per spindle

SPHERICAL JOINTS

Type	Ball studs, upper self-adjusting for wear
Quantity	Two per steering knuckle
Bearing surfaces	
Upper	Two bearings, both non-metallic: one, a teflon-coated phenolic; the other, a teflon-cotton composition
Lower	One bearing, a non-metallic, teflon-cotton composition
Lubrication	
Upper and lower	High pressure grease fitting for each ball stud

SHOCK ABSORBER

Type	Direct, double-acting, hydraulic
Piston diameter	1.00

STABILIZER BAR

Type	Linkless
Material	HR steel
Diameter	.612
Bushing material	Natural or synthetic rubber

FRONT WHEEL ALIGNMENT ●

Design	
Camber (degrees)	P1/2 to P1-1 2
Caster (degrees)	P3 to P4
Toe (per wheel)	1/16 toe-out
Curb	
Camber (degrees)	P1/2 to P1-1 2
Caster (degrees)	P3 to P4
Toe (total)	1/4 to 3/8 toe-in
SAT (degrees)	6 to 7

FRONT SPRINGS

FRONT SPRINGS (all power train combinations)

All except convertibles

Part number	3857688
Type	Coil, right hand helix
Material	AISI A-5160
Cut-off length	101.425
Wire diameter	.447
Pitch diameter	3.900
Inside diameter	3.453
Heights	
Free	12.574
Working (in. @ lb)	6.42 @ 800
Deflection rate	
@ Spring	130
@ Wheel (wheel rate)	71

Convertibles

Part number	3857690
Type	Coil, right hand helix
Material	AISI A-5160
Cut-off length	101.881
Wire diameter	.465
Pitch diameter	3.918
Inside diameter	3.453
Heights	
Free	12.287
Working (in. @ lb)	6.42 @ 880
Deflection rate	
@ Spring	150
@ Wheel (wheel rate)	78

STEERING

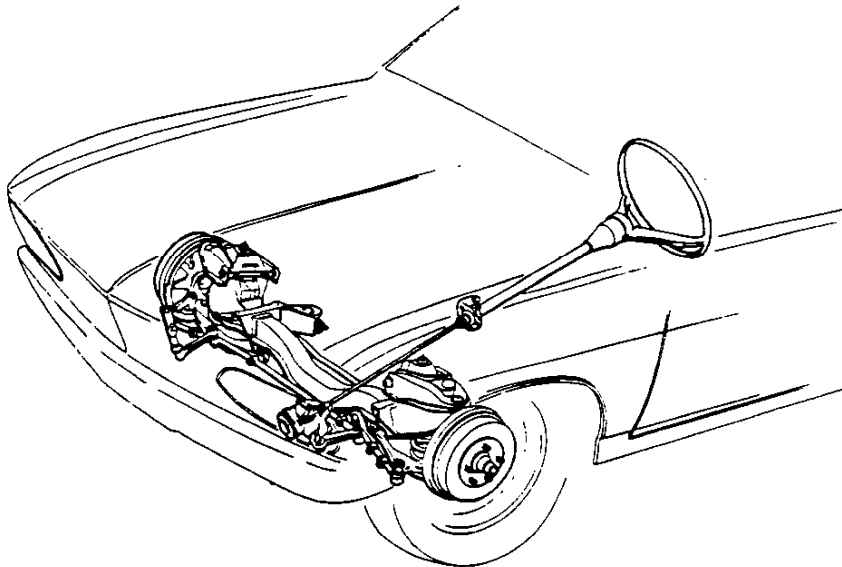

STEERING
CONTINUED
ON PAGE 4

MANUAL STEERING

Description	-----	Semi-reversible, recirculating ball nut steering gear with integral shaft. Telescoping shaft steering available optionally.
System ratios		
Steering gear	-----	18:1
Overall	-----	23.3:1
Turning diameters (ft)		
Outside front, wall to wall	-----	37.5
Outside front, curb to curb	-----	35.2
Inside rear, wall to wall	-----	19.2
Inside rear, curb to curb	-----	20.1
Number of wheel turns, lock to lock	-----	4.70
Outside wheel angle (degrees) with inside wheel		
@ 15 degrees	-----	14
@ 30 degrees	-----	28
@ 36.8 degrees (limit of turn)	-----	34.8
Steering shaft		
Number used	-----	One
Diameter	-----	.75
Steering wheel		
Regular production and RPO N34		
Type	-----	Deep dished
Diameter	-----	16.0
Linkage		
Type	-----	Parallelogram
Location	-----	Front of wheels
Number of tie rods	-----	2
Lubrication points	-----	4; one at each end of each tie rod

REAR SUSPENSION

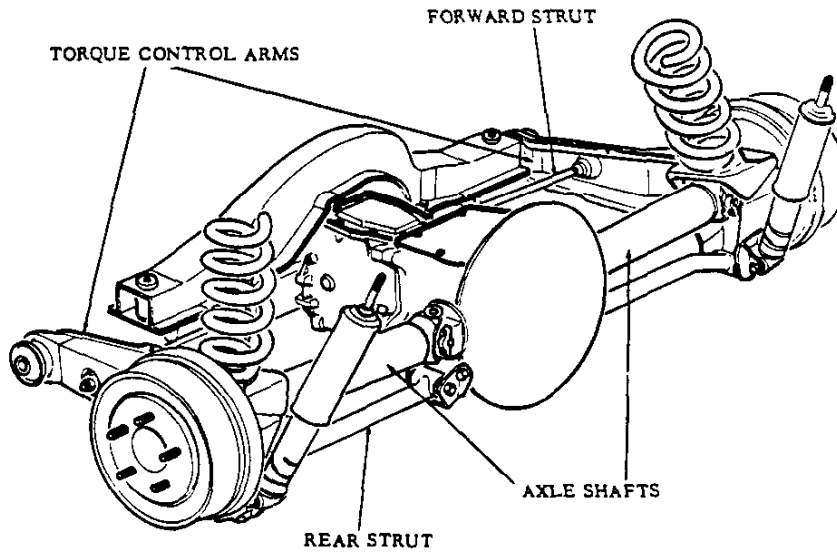

GENERAL

Description ---- Full independent, articulating link type
 Wheel travel, from design height
 Total ----- 7.47
 Jounce ----- 3.02
 Rebound ----- 4.45
 Wheel to spring ratio ----- 1.16

STRUT

Material ----- DF steel
 Diameter ----- .94

SHOCK ABSORBERS

Type ----- Direct, double-acting, hydraulic
 Piston diameter ----- 1.00

REAR WHEEL ALIGNMENT

Design
 Camber (degrees) ----- N1-1/2 to N2-1/2
 Toe (total) ----- 3/16 to 7/16 toe-in
 Curb
 Camber (degrees) ----- N1 to 0
 ● Toe (total) ----- 1/4 to 1/8 toe-in

REAR SPRINGS

REAR SPRINGS (all power train combinations)

Part number ----- 3859201
 Type ----- Coil, right hand helix
 Material ----- AISI A-5160
 Cut-off length ----- 117.532
 Wire diameter ----- .538
 Pitch diameter ----- 4.738
 Inside diameter ----- 4.200
 Heights
 Free ----- 14.467
 Working (in. @ lb) ----- 7.78 @ 1070
 Deflection rate
 @ Spring ----- 160
 @ Wheel (wheel rate) ----- 149

REAR AXLE

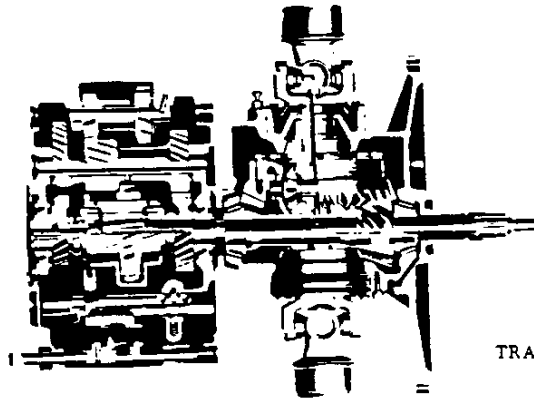

TRANSAXLE WITH 3-SPEED TRANSMISSION

REAR AXLE

Description ----- Semi-floating
 Lubrication
 Type ----- For regular production axles,
 Military Spec. MIL-L-2105-B
 Capacity (pts) ----- 4.0
 Filler plug ----- 3/4 pipe plug
 Viscosity ----- SAE80
 Regular production ratios
 10100 and 10500 ----- 3.27
 10700 ----- 3.55
 Differential carrier
 Type ----- Hypoid gear
 with overhung pinion gear
 supported by two taper roller bearings
 Offset ----- 1.75
 Hypoid gear PD ----- 6.750
 Pinion bearing adjustment ----- Shim
 Cover assemblage ----- Bolted to differential carrier

DIFFERENTIAL

Type ----- 2 pinion

HYPOID AND PINION GEAR TOOTH COMBINATION

3.27 ----- 36,11
 3.55 ----- 32,9

POSITRACTION DIFFERENTIAL

(for availability, see POWER TRAINS)
 Type ----- Two pinion with disc clutch at one side

REAR AXLE
 CONTINUED
 ON PAGE 6

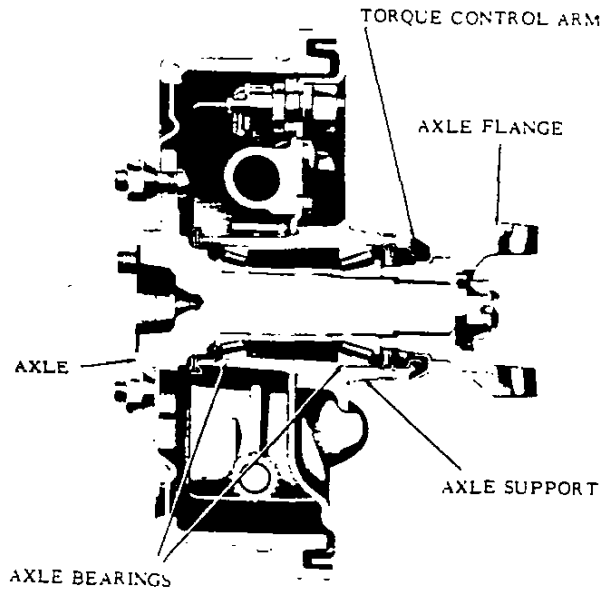

REAR WHEEL AND AXLE

GENERAL

Description ----- Brake drum flange integral with axle which is universally-jointed to axle shaft. Torque control arm bolted to axle support. Axle supported by two taper roller bearings.

AXLE

Material ----- DF steel
 Diameter at outer bearing ----- 1.2513-1.2518
 Diameter at inner bearing ----- 1.1885-1.1890

AXLE SHAFT

Type ----- Welded steel tubing incorporating universal joint at each end

AXLE BEARINGS

Type ----- Taper roller
 Quantity ----- 2 per wheel
 Bearing seals
 Description, outer and inner ---- Steel encased rubber

AXLE FLANGE

Material ----- Malleable iron

AXLE SUPPORT

Material ----- Nodular iron

TORQUE CONTROL ARM

Description ----- Welded steel box section

BRAKES

SERVICE BRAKES, regular production

General	
Type	Duo-servo: 4-wheel hydraulic, reverse self-adjusting
Line pressure @ 100 lb pedal load, psi	783
Braking ratios	
Pedal	6.15:1
Hydraulic	3.29:1
Overall	20.23:1
Distribution of braking effort (theoretical, percent)	
Front wheels	46
Rear wheels	54
Brake drum	
Swept drum area, sq. inches	268.6
Construction	Composite, web cast into rim
Material	
Web	HR steel
Rim	Cast iron alloy
Web thickness	
Front094-.114
Rear094-.114
Diameter, front and rear	9.50
Brake lining	
Material	Full molded asbestos composition
Length	
Primary shoe	9.01
Secondary shoe	9.75
Width	
Front	2.00
Rear	2.50

Thickness, minimum @ C/L	
Primary17
Secondary20
Method of attachment	Bonded
Total effective area, sq. inches	168.9
Master cylinder	
Piston diameter	1.00
Piston travel (with available pedal travel)98
Wheel cylinders	
Piston diameters	
Front875
Rear9375
Foot pedal travel	6.00

PARKING BRAKE

Type	Mechanical pull-rod, pulleyes and cables operate rear service brakes
Total effective area, sq. inches	93.8
Control	Hand-grip ratchet type handle with trigger-release in grip. Located under instrument panel to left of steering column.

STOPLIGHT SWITCH

Type	Mechanical, make-break, normally on
Activation	Brake pedal
Location	On dash panel brace

WHEELS AND TIRES

WHEELS, regular production

Type	Short spoke full disk
Attachment to hub	5 hex nut, 7/16-20 UNF 2B, arranged on a 4.75 dia. bolt circle
Offset	1.00
Size	13 x 5.5J

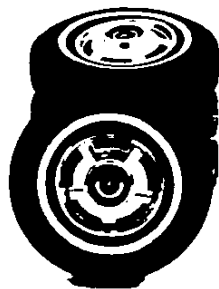

(CORSA WHEEL DISC SHOWN)

TIRES

Type	Rayon tubeless, backwall
Construction	2 ply
Size	6.50-x-13-4PR
Specifications	
Loaded rolling radius	11.6
Loaded rev/mile @ 50 MPH	862
Capacity (lb @ psi)	835 @ 24
Recommended inflation, psi (cold)	
Front	15
Rear	26

BULBS, FUSES, AND CIRCUIT BREAKERS

LAMP		NUMBER REQUIRED AND TRADE NUMBER	CANDLE POWER PER LAMP
Ash tray		1-53	1
Automatic transmission position pattern		1-1445	1
Back up		2-1156	32
Clock (with tachometer option)			
Courtesy		2-631	6
Direction signal indicators		2-1445	1
Dome		1-211	15
Generator (and fan) indicator		1-1895	2
Glove compartment		1-1895	2
Headlamps	Outer	2-4002	High beam, 37.5W Low beam, 55.0W
	Inner	2-4001	High beam, 37.5W
Headlamps hi-beam indicator		1-1445	1
Heater controls		1-1445	1
Instrument cluster		10100 and 10500, 4-1895 10700, 6-1895	2
License plate, rear		1-1155	4
Luggage compartment		1-1003	15
Oil pressure and temperature indicator		1-1895	2
Parking			
Park			4
Turn		2-1157	32
Parking brake alarm		1-257	2
Radio		1-1893	2
Spot lamp, portable		1-4416	30W
Tail			
Tail			4
Stop and turn		2-1157	32
Traffic hazard indicator		1-1445	1
Underhood		1-93	15

CIRCUIT	TYPE OF PROTECTION	LOCATION AND CIRCUIT*
Air conditioning	2 AGC 15 fuses	In line
Ash tray lamp	AGC 3 fuse	Fuse panel (c)
Auto. trans. position pattern lamp	AGC 3 fuse	Fuse panel (c)
Back up lamps		
10100	AGC 10 fuse	Fuse panel (d)
10500 and 10700	AGC 15 fuse	Fuse panel (d)
Cigarette lighter	AGC 10 fuse	Fuse panel (b)
Clock	AGC 10 fuse	Fuse panel (g)
Clock lamp	AGC 3 fuse	Fuse panel (c)
Courtesy lamps	AGC 10 fuse	Fuse panel (g)
Direction signal indicator lamps	AGC 3 fuse	Fuse panel (c)
Dome lamp	AGC 10 fuse	Fuse panel (b)
Folding top motor	40 amp CB	Instrument panel
Fuel gage		
10100	AGC 10 fuse	Fuse panel (d)
10500 and 10700	AGC 15 fuse	Fuse panel (d)
Generator (and fan) indicator lamp		
10100	AGC 10 fuse	Fuse panel (d)
10500 and 10700	AGC 15 fuse	Fuse panel (d)
Glove compartment lamp	AGC 10 fuse	Fuse panel (g)
Headlamps	15 amp CB	Light switch
Headlamps hi-beam indicator lamp	15 amp CB	Light switch
Heater		
10100	AGC 10 fuse	Fuse panel (d)
10500 and 10700	AGC 15 fuse	Fuse panel (d)
Heater control lamp	AGC 3 fuse	Fuse panel (c)
Instrument cluster lamp	AGC 3 fuse	Fuse panel (c)
License plate, rear	AGC 10 fuse	Fuse panel (b)
Luggage compartment lamp	AGC 10 fuse	Fuse panel (b)
Oil press. and temp. indicator lamp		
10100	AGC 10 fuse	Fuse panel (d)
10500 and 10700	AGC 15 fuse	Fuse panel (d)
Parking lamps	15 amp CB	Light switch
Parking brake alarm lamp		
10100	AGC 10 fuse	Fuse panel (d)
10500 and 10700	AGC 15 fuse	Fuse panel (d)
Radio and radio lamp	AGC 2.5 fuse	Fuse panel (e)
Spot lamp, portable	AGC 10 fuse	Fuse panel (b)
Tachometer gage	AGC 15 fuse	Fuse panel (d)
Tail lamps	AGC 10 fuse	Fuse panel (b)
Temperature gage and buzzer	AGC 15 fuse	Fuse panel (d)
Underhood lamp	AGC 4 fuse	In line
Windshield wiper, single speed	SAE 20 fuse	Fuse panel (f)
Windshield wiper, two-speed	SAE 20 fuse	Fuse panel (f)
	14 amp CB	Switch

* Letter suffix indicates same circuit.

POWER TRAINS

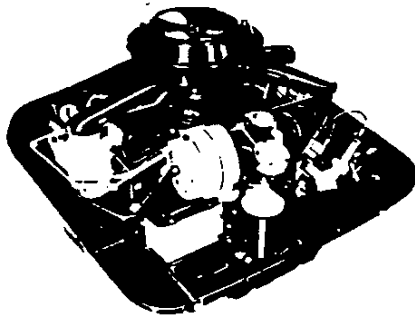

POWER TEAM COMBINATIONS	2
ENGINE DATA AND RATINGS	3
ENGINE SPEED AND PISTON TRAVEL	3
VEHICLE PERFORMANCE FACTORS	4
ENGINE OUTPUT CURVES	5
PRINCIPAL COMPONENTS	7
FUEL SYSTEM	10
EXHAUST AND VENTILATION SYSTEM	11
COOLING SYSTEM	11
LUBRICATION SYSTEM	12
ELECTRICAL SYSTEM	12
CLUTCHES	15
THREE AND FOUR SPEED TRANSMISSIONS	16
POWERGLIDE	17

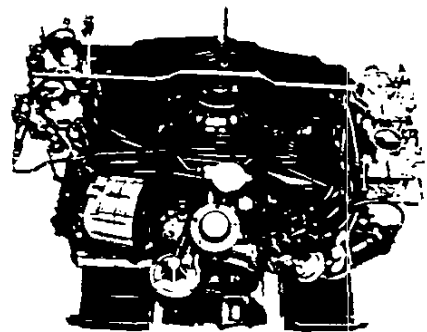

POWER TEAM COMBINATIONS

ENGINE	EQUIPMENT	TRANSMISSION	AXLE RATIOS*		
			General Purpose Standard	Special Purpose or Mountain	High Performance
164 CUBIC INCH TURBO-AIR 95 HP 6-CYLINDER	2-SINGLE BARREL CARBURETORS HYDRAULIC LIFTERS	10100 & 1500 MODEL S			
		3-SPEED (3.22:1 low)	3.27:1	3.55:1	
		4-SPEED (3.20:1 low) POWERGLIDE	3.27:1 3.27:1	3.55:1 3.55:1	
164 CUBIC INCH(A) TURBO-AIR 140 HP 6-CYLINDER	4-SINGLE BARREL CARBURETORS HYDRAULIC LIFTERS SPECIAL CAMSHAFT	10700 MODELS			
		3-SPEED (3.22:1 low)	3.55:1	3.27:1	
		4-SPEED (3.20:1 low) POWERGLIDE (B)	3.55:1 3.55:1	3.27:1	
164 CUBIC INCH TURBO-AIR 110 HP 6-CYLINDER (RPO L62)	2-SINGLE BARREL CARBURETORS HYDRAULIC LIFTERS SPECIAL CAMSHAFT	10100 & 10500 MODELS			
		3-SPEED (3.22:1 low)	3.27:1	3.55:1	
		4-SPEED (3.20:1 low) POWERGLIDE	3.27:1 3.55:1	3.55:1	
164 CUBIC INCH TURBOCHARGED 180 HP 6-CYLINDER (RPO L87)	SINGLE BARREL SIDE DRAFT CARBURETOR SUPERCHARGED SPECIAL CAMSHAFT	10700 MODELS			
		3-SPEED (3.22:1 low) and 4-SPEED (3.20:1 low)			3.55:1 (Std.)

- A - AVAILABLE AS AN OPTION (RPO L63) ON 10100 & 10500 MODELS
 B - AVAILABLE WITH RPO L63 ONLY
 * - POSITRACTION AXLE RATIOS AVAILABLE IN COMBINATIONS SHOWN

MULTIPLICATION FACTORS

with MANUAL TRANSMISSIONS

ENGINE	TRANSMISSION	TOTAL GEAR REDUCTION*					AXLE RATIO	MAXIMUM AXLE TORQUE LOW GEAR (LB-FT)§
		1st	2nd	3rd	4th	Rev		
95 HP	3-Speed	10.53	6.02	3.27		10.53	3.27:1	1253
	4-Speed	10.46	7.16	4.71	3.27	11.96	3.27:1	1245
110 HP	3-Speed	10.53	6.02	3.27		10.53	3.27:1	
	4-Speed	10.46	7.16	4.71	3.27	11.96	3.27:1	
140 HP	3-Speed	11.43	6.53	3.55		11.43	3.55:1	
	4-Speed	11.36	7.77	5.11	3.55	12.99	3.55:1	
180 HP	3-Speed	11.43	6.53	3.55		11.43	3.55:1	
	4-Speed	11.36	7.77	5.11	3.55	12.99	3.55:1	

with AUTOMATIC TRANSMISSIONS

ENGINE	TRANSMISSION	SELECTOR POSITION	TOTAL TORQUE MULTIPLICATION*	AXLE RATIO
95 HP	Powerglide	Drive	15.47:1 - 3.27:1	3.27:1
		Low & Reverse	15.47:1 - 5.95:1	
110 HP & 140 HP	Powerglide	Drive	16.79:1 - 3.55:1	3.55:1
		Low & Reverse	16.79:1 - 6.46:1	

* - Axle ratio x transmission ratio.

§ - Gear reduction x maximum net engine torque x efficiency (8.90 in direct drive, 8.85 all others).

ENGINE DATA AND RATINGS

GENERAL DATA

Piston Displacement	Synchromesh	Powerglide®
	164	
Type	Horizontal opposed OHV	
Number Cylinders	6	
Bore and Stroke (nom'nal)	3.437 x 2.94	
Compression Ratio	8.25:1 (A)	
Taxable (SAE) Horsepower	28.4	
Firing Order	1-4-5-2-3-6	
Idling Speed (RPM)	500 (B)	
Compression Press. (PSI) @ Cranking Speed, Engine Hot	140	
Lubrication	Full pressure	
Power Plant Mounting	Two front and one rear shear type	
Measurements	Width (over carburetors)	30.66 (C)
	Length (incl. clutch hsg. & oil filter)	28.55
	Height (top air cleaner to bottom oil pan)	23.57 (C)

- A - On 110 HP Engine and 4-Single Bbl. Carb. 140 HP Engine C.R. is 9.25:1.
 B - 600 RPM on 110 HP Engine and 4-Single Bbl. Carb. 140 HP Engine; 850 RPM on Turbocharged 150 HP Engine.
 C - Turbocharged 150 HP Engine - Width (induction port flange to exhaust pipe) 29.30; Height 23.31.

ADVERTISED ENGINE RATINGS

Engine Designation		P6 - 95 HP Turbo-Air 164	P6 - 110 HP Turbo-Air 164	P6 - 140 HP Turbo-Air 164	P6 - 180 HP Turbocharged
Availability		Standard	RPO - L62	Std. 10700 Models RPO-L63 10100 & 10500	RPO - L87
Carburetor		Two-Single barrel (one for each cylinder bank)		Four-Single bbl. (two for each bank)	One-Single barrel
Brake Horsepower	Gross	95 @ 3600	110 @ 4400	140 @ 5200	180 @ 4000
	Net	78 @ 3600			
Torque (Lb.-Ft)	Gross	154 @ 2400	160 @ 2800	160 @ 3600	265 @ 3200
	Net	140 @ 2400			

ENGINE SPEED AND PISTON TRAVEL

Transmission	3-Speed		4-Speed		Powerglide (a)		
	3.27:1	3.55:1	3.27:1	3.55:1	3.27:1	3.55:1	
Rear Axle Ratio							
Tire Size	6.50 x 13-4PR						
Crankshaft Revolutions per Mile	2763.2	2999.8	2763.2	2999.8	2763.2	2999.8	
Crankshaft RPM @ 1 MPH	Low	148.3	161.0	147.7	160.0	83.8	91.0
	Second	84.7	92.0	100.9	109.5		
	Third	46.0	50.0	66.3	72.0	46.0 (b)	50.0 (b)
	Fourth			46.0	50.0		
	Reverse	148.3	161.0	168.5	183.0	83.8	91.0
Piston Travel (ft./mile)	1354.0	1469.9	1354.0	1469.9	1354.0	1469.9	

- (a) Powerglide not available with Turbocharged 150 HP engine.
 (b) Direct drive.

VEHICLE PERFORMANCE FACTORS

ENGINE - 164 Cu.In.	Standard 95 HP	Standard 140 HP	RPO L63 140 HP	RPO L62 110 HP	RPO L87 180 HP
MODEL	10139	10737	10139	10139	10737

3-SPEED TRANSMISSION

Performance Weight (pounds)	3093	3161	3106	3092	3174
Pounds per Gross Horsepower	32.56	22.58	22.19	28.11	17.63
Pounds per Cu.In. Displacement	18.86	19.27	18.94	18.85	19.35
Gross HP per Cu.In. Displacement	.579	.854	.854	.671	1.097
Power Displacement (cu.ft./mile)	131.12	142.35	142.35	131.12	142.35
Displacement Factor (cu.ft./ton mile)	84.81	90.09	91.66	84.81	89.70

4-SPEED TRANSMISSION

Performance Weight (pounds)	3100	3168	3113	3099	3181
Pounds per Gross Horsepower	32.63	22.63	22.24	28.17	17.67
Pounds per Cu.In. Displacement	18.90	20.57	18.98	18.90	19.39
Gross HP per Cu.In. Displacement	.579	.854	.854	.671	1.097
Power Displacement (cu.ft./mile)	131.12	142.35	142.35	131.12	142.35
Displacement Factor (cu.ft./ton mile)	84.59	89.87	91.48	84.65	89.53

POWERGLIDE*

Performance Weight (pounds)	3101		3114	3100	
Pounds per Gross Horsepower	32.65		22.24	28.18	
Pounds per Cu.In. Displacement	18.91		18.99	18.90	
Gross HP per Cu.In. Displacement	.579		.854	.671	
Power Displacement (cu.ft./mile)	131.12		142.35	142.35	
Displacement Factor (cu.ft./ton mile)	84.57		91.43	91.84	

* - Data computed assuming zero slippage in torque converter.

GLOSSARY

Performance Weight	Curb Weight plus 600 Lb (weight of four 150 lb passengers)
Power Displacement	$\frac{\text{Crankshaft Revs Mi} \times \text{Piston Displacement}}{2 \times 1728}$
Displacement Factor	$\frac{\text{Power Displacement}}{\text{Performance Wt (tons)}}$

ENGINE OUTPUT CURVES

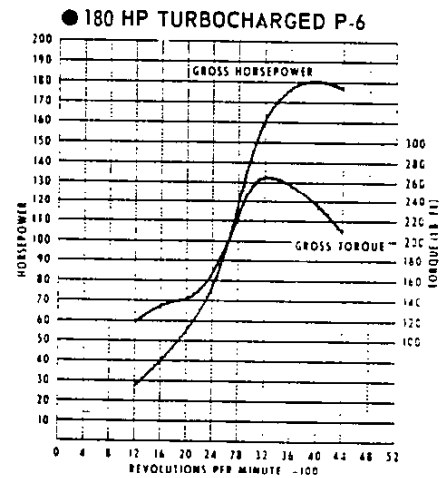
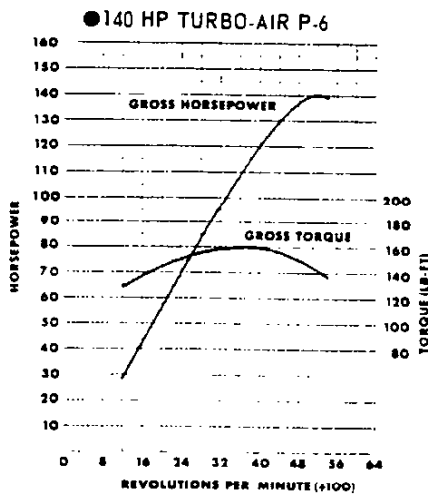
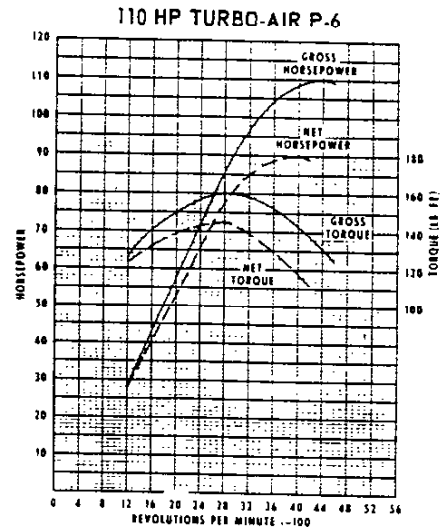
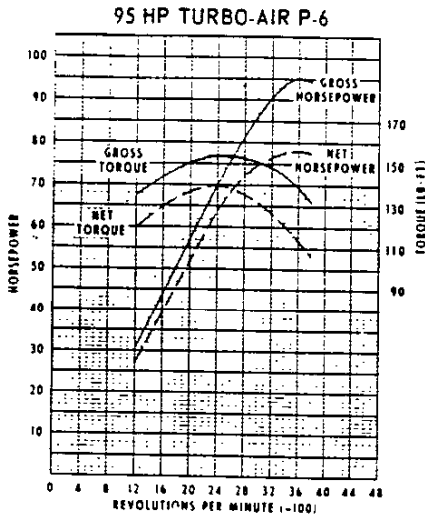

The engine output curves represent full throttle performance as obtained from dynamometer test data corrected to standard barometric pressure 29.92 inches of mercury and standard temperature of 60 degrees F.

GROSS POWER and TORQUE were obtained in a regular dynamometer test with the dynamometer exhaust system,

no fan, generator not charging, optimum spark advance, and optimum fuel setting.

NET POWER and TORQUE were obtained from a dynamometer test simulating actual operating conditions when the engine is in its vehicle, except the generator is not charging.

PRINCIPAL COMPONENTS

CRANKCASE

Material ----- Cast Aluminum
 Type ----- Cast into left and right halves
 No. of Bulkheads ----- 4
 Bolt No. & Size ----- 8: .4375 dia., 20 UNF - 2A
 Studs (cyl. & cyl. head assy.) ----- 12 left & 12 right half
 Bore Spacing (centerline to centerline) ----- 4.85

CYLINDERS

Material ----- Cast iron
 Type ----- Individually cast with integral cooling fins
 Bore Diameter ----- 3.4370-3.4400
 Numbering Arrangement (front to rear)
 Left bank ----- 6-4-2
 Right bank ----- 5-3-1

CYLINDER HEADS

Material ----- Permanent mold cast aluminum
 with integral cooling fins

COMBUSTION CHAMBER VOLUME

(Total chamber volume of assembled engine with piston at top center)

95 HP Engine ----- 3.90 Cu. In.
 110 HP Engine ----- 3.51 Cu. In.
 140 HP Engine ----- 3.42 Cu. In.
 180 HP Engine ----- 4.00 Cu. In.

CRANKSHAFT

Material ----- Forged alloy steel
 Journal ----- Hardened on 140 & 180 HP engines
 ● End play ----- .002-.006
 Counterweights ----- None
 Crank arm length ----- 1.47
 Vibration damper ----- All engines except
 95 HP engine with synchromesh trans.
 Timing gear & material ----- Helical cut, steel
 Pulley pitch diameter ----- 6.64

INLET MANIFOLD

Type ----- Cast integral with cylinder head

EXHAUST MANIFOLD

Material ----- Cast alloy iron
 Type ----- Straight-fitted to three steel sleeves
 pressed into cyl. head exhaust ports

MAIN BEARINGS

Material ----- Premium aluminum
 Type ----- Precision, removable
 Thrust Against Bearing No. ----- 1
 Clearance ----- .0012-.0037

Dimensions Bearing	Theoretical Inner Dia.	Effective Length	Projected Area
1	2.1008	.55	1.6542
2	2.1008	.52	1.5798
3-4	2.1018	.52	1.5805

CRANKSHAFTS AND BEARINGS

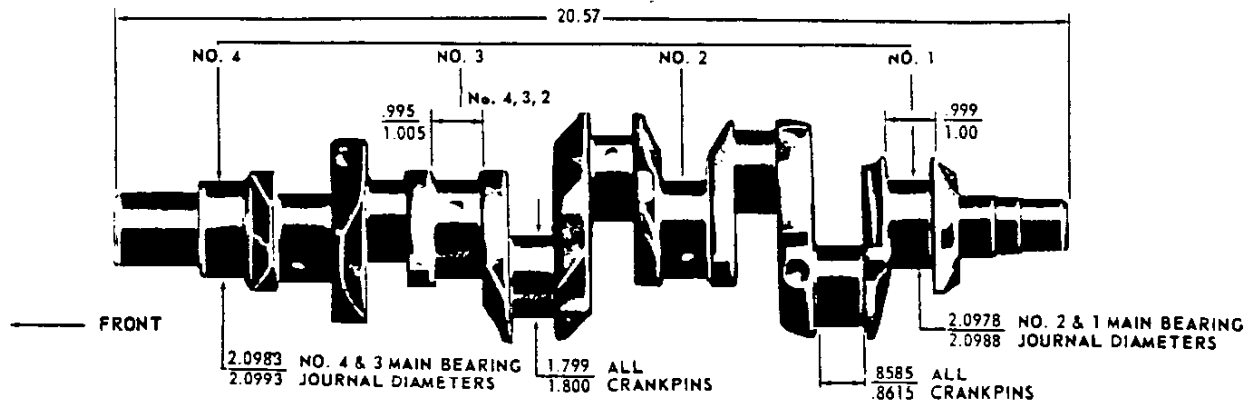

CAMSHAFT

Material ----- Cast alloy iron
 Lobe lift - inlet & exhaust
 95 HP engine ----- .2567
 110 HP & 140 HP engines ----- .2605
 ● 180 HP engine ----- .2494

BEARINGS ----- No inserts aluminum crankcase machined for bearing surface

VALVE TRAIN

Type ----- Individually mounted rocker arms, push rod actuated
 Lifters ----- Hydraulic
 Push Rods
 Type & Material ----- Hollow, steel
 Ends ----- Hardened
 Housing ----- Welded steel tubes
 Rocker Arms
 Type & Material ----- Stamped steel
 Ratio
 95 HP engine ----- 1.57:1
 110 HP, 140 HP & 180 HP engines ----- 1.50:1

VALVE SPRINGS

Diameter (I.D.) ----- .872-.888
 Installed Length (In. @ Lb.)
 Valves Closed ----- 1.660 @ 78-86
 Valves Opened ----- 1.260 @ 170-180
 Free Length ----- 2.08
 Valve Spring Dampers ----- Flat steel coil

VALVE LIFT

Inlet & Exhaust
 95 HP engine ----- .4030
 110 HP & 140 HP engines ----- .3907
 ● 180 HP engine ----- .3741

VALVE TRAIN LASH

Inlet ----- Zero
 Exhaust ----- Zero

VALVE TIMING (Crankshaft degrees)

95 HP Engine	Excluding Ramps	Including Ramps
Inlet valve		
Opens - BTC	26°	44°
Closes - ABC	60°	88°
Duration	266°	312°
Exhaust valve		
Opens - BBC	60°	78°
Closes - ATC	26°	54°
Duration	266°	312°

110 HP & 140 HP Engines	Excluding Ramps	Including Ramps
Inlet valve		
Opens - BTC	37°	55°
Closes - ABC	81°	105°
Duration	298°	340°
Exhaust valve		
Opens - BBC	79°	97°
Closes - ATC	39°	63°
Duration	298°	340°

● 180 HP Engine	Excluding Ramps	Including Ramps
Inlet valve		
Opens - BTC	70°	72°
Closes - ABC	86°	110°
Duration	336°	372°
Exhaust valve		
Opens - BBC	98°	110°
Closes - ATC	46°	70°
Duration	324°	360°

CAMSHAFT AND BEARINGS

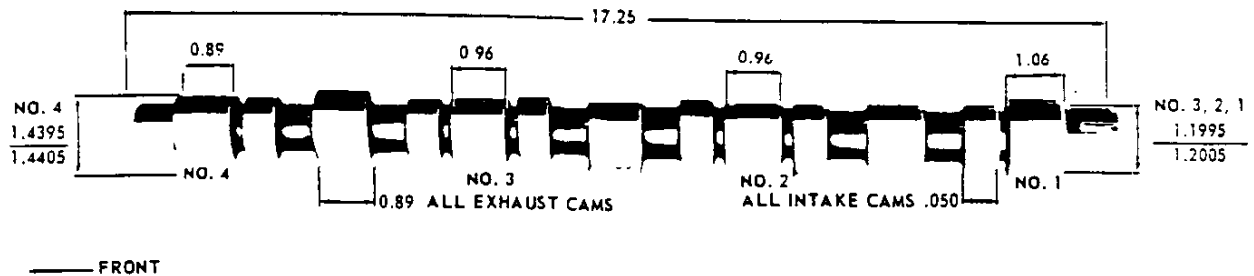

PRINCIPAL COMPONENTS—Cont'd.

INLET VALVES

Material	High alloy steel
Coating	Aluminized face
Valve guide material	Cast alloy iron
Valve seat material	Sintered alloy iron

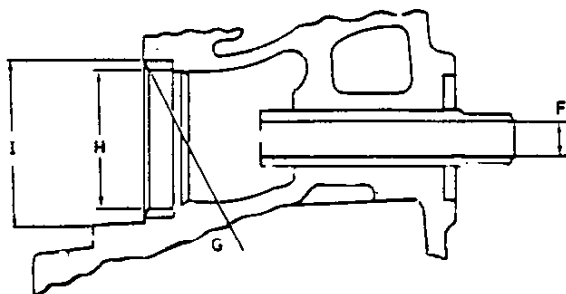
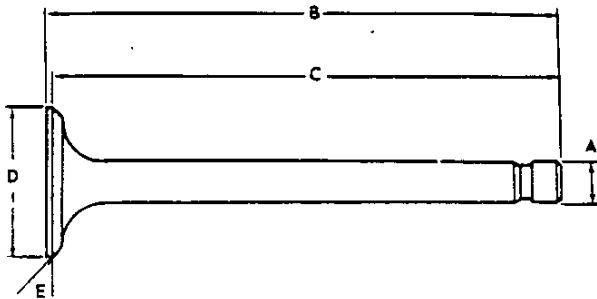

A - Stem diameter	.3414-.3422
B - Overall length	
95 HP, 110 HP & 180 HP engines	4.489-4.509
140 HP engine	4.5462-4.5712
C - Gage length	
95 HP, 110 HP & 180 HP engines	4.392-4.402
140 HP engine	4.4712-4.4812
D - Overall head diameter	
95 HP, 110 HP & 180 HP engines	1.335-1.345
140 HP engine	1.715-1.725
E - Angle of face	44 degrees
F - Guide diameter	.3432-.3442
G - Angle of seat	45 degrees
H - Valve guide (ID)	
95 HP, 110 HP & 180 HP engines	1.257-1.267
140 HP engine	1.637-1.647
I - Valve guide (OD)	
95 HP, 110 HP & 180 HP engines	1.4285-1.4295
140 HP engine	1.8085-1.8095

EXHAUST VALVES

Material	
95 HP, 110 HP & 140 HP engines	High alloy steel with "cobalt-based" alloy face
180 HP engine (two-piece welded)	
Head, face & neck	Super alloy (Nimonic 80A)
Stems	Silicon & chromium alloy steel
Valve guide material	
95 HP, 110 HP & 140 HP	Cast alloy iron
180 HP	Aluminum bronze alloy
Valve seat material	
95 HP, 110 HP & 180 HP	Cast chromium steel alloy
140 HP	Cast nickel steel alloy

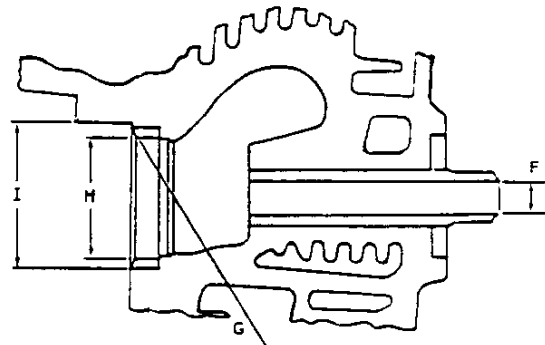
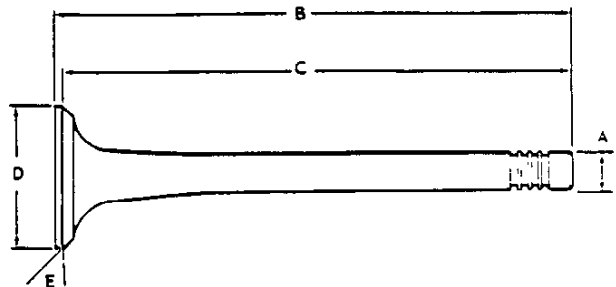

A - Stem diameter	.3407-.3418
B - Overall length	
95 HP, 110 HP & 180 HP engines	4.494-4.514
140 HP engine	4.493-4.518
C - Gage length	
95 HP, 110 HP & 180 HP engines	4.387-4.397
140 HP engine	4.413-4.423
D - Overall head diameter	
95 HP, 110 HP & 180 HP engines	1.235-1.245
140 HP engine	1.355-1.365
E - Angle of face	44 degrees
F - Guide diameter	.3432-.3442
G - Angle of seat	45 degrees
H - Valve guide (ID)	
95 HP, 110 HP & 180 HP engines	1.081-1.091
140 HP engine	1.201-1.211
I - Valve guide (OD)	
95 HP, 110 HP & 180 HP engines	1.2865-1.2875
140 HP engine	1.4065-1.4075

PISTON

Material ----- Cast aluminum alloy
 Head type ----- Flat
 Skirt type ----- Slipper, autothermic
 Top land clearance ----- .021-.040
 Skirt clearance ----- .0011-.0017
 Compression ring groove depth ----- .193-.199
 Oil control ring groove depth ----- .186-.193
 Pin bore offset ----- .055-.065
 Compression height ----- 1.589-1.591

OIL CONTROL RINGS

Material ----- Steel
 Type ----- Multi-piece (two rails and one spacer)
 Width ----- .1215-.1255 assembled
 Wall thickness ----- .135-.141
 Gap (rails) ----- .015-.055
 Rail coating ----- Chrome plate

COMPRESSION RINGS - UPPER

Material
 95 HP & 110 HP engines ----- Cast alloy iron
 140 HP & 180 HP engines ----- High strength ductile iron
 Inside bevel ----- Bottom edge 30 degrees to
 piston vertical axis
 Ring face ----- Tapered
 Coating
 95 HP & 110 HP engines ----- Chrome plated
 140 HP & 180 HP engines ----- Molybdenum
 Width ----- .0620-.0625
 Wall thickness
 95 HP & 110 HP engines ----- .162-.172
 140 HP & 180 HP engines ----- .145-.155
 Gap ----- .010-.020

PISTON PINS

Material ----- Alloy steel
 Length ----- 2.630-2.650
 Diameter ----- .7999-.8002
 Clearance in piston ----- .00015-.00025
 Pin mounting ----- Pressed in rod

CONNECTING RODS

Material ----- Drop forged steel
 Length (center to center) ----- 4.719-4.721

COMPRESSION RING - LOWER

Material ----- Cast alloy iron
 Inside bevel ----- Top edge 30 degrees to
 piston vertical axis
 Ring face ----- Tapered
 Coating ----- Wear resistant
 Width ----- .0620-.0625
 Wall thickness ----- .162-.172
 Gap ----- .010-.020

CONNECTING ROD BEARINGS

Material ----- Premium aluminum
 Type ----- Precision removable
 Clearance ----- .0007-.0028
 Theo. I.D. ----- 1.8018
 Effective length ----- .649
 End play ----- .005-.010

FUEL SYSTEM

FUEL TANK

Capacity (Gal) ----- 14
 Location ----- Upper front compartment floor
 Filler Location ----- Left front fender crown

FUEL FILTERS, DUAL

In Fuel Tank ----- Mesh strainer
 95 HP, 110 HP & 140 HP Engines ----- Sintered bronze
 filter in carburetor inlet
 180 HP Engine ----- Replaceable in-line paper element
 between fuel pump & carburetor

FUEL PUMP ASSEMBLY

Drive ----- Eccentric on rear end of crankshaft
 Type ----- Mechanical
 Location ----- Mounted on engine rear housing
 Pressure Range ----- 5.50-6.75

AIR CLEANERS

Type
 95 HP & 110 HP Engine --- One, with single air horn;
 centrally mounted on tubular crossover duct
 140 HP ----- One; with dual air horns; centrally
 mounted on solvated tubular arms;
 chrome plated cover
 180 HP ----- One, with large oval air horn
 connected to carb. air horn; chrome plated
 Element ----- Oil-wetted paper

CARBURETOR

Make & Number
 95 HP & 110 HP ----- Rochester - Two; one for each
 cylinder bank
 140 HP ----- Rochester - Four; set of one primary
 and one secondary for each cylinder bank
 180 HP ----- Carter - One; connected to
 supercharger

Type

95 HP, 110 HP & 140 HP Engines ----- Single barrel
 downdraft
 180 HP Engine ----- Triple venturi, sidedraft
 SAE Flange Size
 95 HP, 110 & 140 HP Engines ----- .075
 180 HP Engine ----- 1.25
 Throttle Bore
 95 HP, 110 HP & 140 HP Engines ----- 1.25
 180 HP Engine ----- 1.50
 Venturi Diameter
 95 HP, 110 HP & 140 HP Engines ----- 1.00
 180 HP Engine ----- 1.375

SUPERCHARGER (180 HP Engine only)

Type ----- Turbo-Supercharger
 (Turbine driven compressor)
 Make ----- Thompson
 Turbine ----- Single-stage, in flo. type
 Material ----- High temperature cobalt base alloy
 Diameter (in) ----- 2.97
 Blades ----- 11, equally spaced
 Drive ----- Engine exhaust gases
 Compressor ----- Centrifugal impeller
 Material ----- Die cast aluminum alloy
 Diameter (in) ----- 3.00
 Blades ----- 14, equally spaced
 Drive ----- Solid shaft from turbine
 Bearing ----- One piece floating bushing
 Material ----- Aluminum alloy
 Lubrication ----- Engine oil full pressure
 Induction Crossover Tube
 Function ----- Fuel-air mixture drawn from
 the single barrel carburetor by the super-
 charger and expelled into the induction cross-
 over tube which supplies each cylinder bank

CHOKE

Type ----- Automatic

EXHAUST AND VENTILATION SYSTEM

TYPE

95 HP, 110 HP & 180 HP Engine ----- Single
140 HP Engine ----- Dual

MUFFLER

Type ----- Oval, reverse flow
Construction ----- Heads and body joined by
rolled lock seam construction

Shell

95 HP & 110 HP Engines ----- .036 cold rolled steel
140 HP Engine (LH & RH) ----- .036 cold rolled steel
180 HP Engine ----- .036 sheet steel, aluminum coating

Wrap ----- .030 indented asbestos sheet

Cover ----- .018 sheet steel, aluminum coating

Heads

95 HP & 110 HP Engines ----- .060 sheet steel,
aluminum coating

140 HP Engine (LH & RH) -- .060 sheet stl, alum. cting.

180 HP Engine ----- .048 sheet steel, aluminum coating

Baffles

95 HP Engine ----- 3; #1 & 2 - .036,
#3 - .060 cold rolled steel

110 HP Engine ----- 3; .036 cold rolled steel

140 HP Engine ----- 3; .036 cold rolled steel

180 HP Engine ----- 3; .036 sheet steel, alum. coating

Length

95 HP, 110 HP & 140 HP Engines (body) ----- 17.76

180 HP Engine (including pipe extensions) ----- 17.88

Height (I.D.) ----- 9.25

Width (I.D.) ----- 5.00

EXHAUST PIPE

Dimensions (O.D.)

Main

95, 110 & 180 HP Engines ----- 1.875

140 HP Engines (Dual) ----- 1.625

Wall Thickness ----- .067-.081

SUPERCHARGER INLET PIPE (180 HP Engine)

Dimensions (O.D.) ----- 1.875

Wall Thickness ----- .081-.097

SUPERCHARGER OUTLET PIPE (180 HP Engine)

Dimensions (O.D.) ----- 2.50

Wall Thickness ----- .067-.081

TAIL PIPE

Dimensions (O.D.)

95 HP Engine ----- 1.50

110 HP & 140 HP Engine ----- 1.75

180 HP Engine ----- 2.50

Wall Thickness ----- .042-.052

Coating

95 HP, 110 HP & 140 HP Engines ----- Aluminum

180 HP Engine ----- Chrome plate

ENGINE VENTILATION

Type ----- Closed-positive

COOLING SYSTEM

GENERAL

Type ----- Forced air cooling
Engine enclosed by sheet metal shrouds to
direct air over engine components. Cooling
controlled by thermostatically regulated air
exhaust doors at rear of each lower shroud

ENGINE BLOWER

Type ----- Centrifugal

Location ----- Mounted horizontally on
top center of engine

Material ----- Magnesium

Diameter ----- 11.18

Number of Vanes ----- 11

Drive ----- By "V" belt from crankshaft over
idler and generator pulleys

Air Flow ----- 1460 CFM @ 4000 Engine RPM

Blower Pulley PD ----- 4.1875

Ratio (Blower to Engine Speed) ----- 1.58:1

Idler Pulley PD ----- 3.32

Belt ----- "V"

Pitch Line ----- 55.74

Width ----- .380

Angle of "V" ----- 40°

ENGINE COOLING AIR THERMOSTATS

Type ----- Bellows (seamless)

Make ----- Harrison

Bellows start to open at ----- 205°F

LUBRICATION SYSTEM

GENERAL

Type ----- Controlled full pressure
 Main Bearings ----- Pressure
 Connecting Rods ----- Pressure
 Piston Pins ----- Splash
 Cylinder Walls ----- Conn. rod bearing throw-off
 Camshaft Bearings ----- Pressure
 Valve Lifters ----- Pressure
 Rocker Arms ----- Pressure
 Timing Gears ----- Main & cam bearing throw-off
 Oil Pressure Sending Unit
 Type ----- Electric
 Actuation ----- Opens or closes circuit @ 2 to 6 PSI
 Oil Filler
 Cap ----- Pressure, twist type
 Location ----- Top rear of engine

CRANKCASE CAPACITY (Qt)

Refill ----- 4.0
 Refill with Filter Change ----- 4.5

OIL PUMP

Type ----- Gear
 Driven By ----- Distributor
 Regulator Valve ----- Opens between 40-45 lbs
 Oil Pressure @ 2000 RPM ----- 30 PSI
 Intake Type ----- Fixed
 Capacity (GPM @ Eng RPM) ----- 9 @ 4000

OIL FILTER

Make ----- AC
 Type ----- Full flow throwaway canister
 Location ----- Rear section of engine
 Capacity (Pts) ----- 1.0
 By-Pass Valve ----- Opens between 9 to 11 PSI

OIL COOLER

Make ----- Harrison
 Material ----- Aluminum
 Location ----- Left bank of cylinder to rear
 By-Pass Valve ----- Opens between 9 to 11 PSI
 drop in pressure
 No. of Plates ----- 8; Turbocharged 12

LUBRICANT GRADES AND TEMPERATURES

32°F & Above ----- SAE30*
 10°F to 32°F ----- SAE10W
 Below 10°F ----- SAE5W-20
 * Always use SAE30 if temperature is above 60°F

OIL PAN DRAIN SCREW

Type ----- Hex head
 Location ----- Lower front edge of oil pan
 Size Hex Head ----- .500-.575
 Thread ----- 1 2-20 UNF 2A
 Length ----- 0.51
 Diameter ----- .410-.430

ELECTRICAL SYSTEM

SUPPLY SYSTEM

BATTERY

Make ----- Delco-Remy
 Voltage Rating ----- 12
 Capacity ----- 44 amp hr @ 20 hr rate
 Total Number of Plates ----- 54
 Number of Cells ----- 6
 Terminal Grounded ----- Negative
 Location ----- Left hand side engine compartment

GENERATOR

Make ----- Delco-Remy
 Type ----- Diode rectified

Rating

Amps ----- 9-37
 Volts ----- 12-15
 Drive ----- Blower belt
 Pulley Pitch Diameter ----- 2.88
 Ratio (Gen. to Engine Speed) ----- 2.30:1

REGULATOR

Make ----- Delco-Remy
 Type ----- Two unit, vibrator
 Voltage Regulator
 Voltage ----- 13.8-14.8 @ 85 F
 Field Relay (Combination light and field relay)
 Closing Voltage ----- 1.3 Volts @ 80 F
 Location ----- Left front engine compartment

STARTING SYSTEM

STARTING MOTOR

Make ----- Delco-Remy
 Rotation (drive end view) ----- Clockwise
 Test Condition ----- Engine at operating temperature
No Load Test
 Amps ----- 69
 Volts ----- 10.6
 RPM ----- 6200-9400
Motor Drive
 Engagement ----- Solenoid
 Pinion meshes at ----- Rear
 Pinion tooth no. ----- 9
 Starter ring gear tooth no. ----- 147
 Mounting ----- Bolted to clutch housing

IGNITION SYSTEM

DISTRIBUTORS ----- Refer to chart below

COIL

Make ----- Delco-Remy
 Type ----- 12 Volt
Amperes Drawn
 Engine stopped ----- 4.0
 Engine idling ----- 1.8

SPARK PLUGS

Make ----- AC
 Model ----- 46FF (44FF on 110, 140 & 180 HP)
 Thread Size (mm) ----- 14
 Gap ----- .033-.038; .028-.033 on 110, 140 & 180 HP
 Torque ----- 25 lb ft

CABLE ----- Linen core impregnated
 with electrical conducting material and
 insulation of rubber with neoprene jacket

DISTRIBUTORS	95 HF Synchronesh	95 HP with Powerglide	110 HP All Trans- missions	140 HP All Trans- missions	180 HP Synchronesh
Make	Delco-Remy				
Model	110310	1110311	1110219	1110330	1110329
Type	Single Breaker				
Cam Angle	31°-34°				
Breaker Gap	.019 (new)				
Breaker Arm Tension	19-23 oz				
Centrifugal Advance Begins (RPM)	700	1700	800	800	4000
Max Degrees @ RPM	28 @ 4200	20 @ 4200	20 @ 4800	18 @ 2800	18 @ 4900
Vacuum Advance Begins (In. Hg)	6.00	7.00	7.00	6.00	*
Max Degrees @ In. Hg	24 @ 14	24 @ 15	24 @ 15	22 @ 14	*
Timing (Initial Design Setting)	6°	14°	14°	18°	24°
Crankshaft Degrees @ RPM (with vacuum spark line disconnected)	BTC @ 500	BTC @ 500	BTC @ 600	BTC @ 650	BTC @ 830
Timing Mark Location	Crankshaft Pulley				

* - Diaphragm Pressure Retard: -Begins @ Mnfld. Pressure-0 @ 2 psi Max. Mnfld. Pressure-12° @ 4-1 2 psi.

ELECTRICAL SYSTEM

95 HORSEPOWER ENGINE

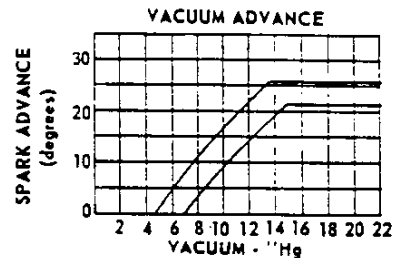
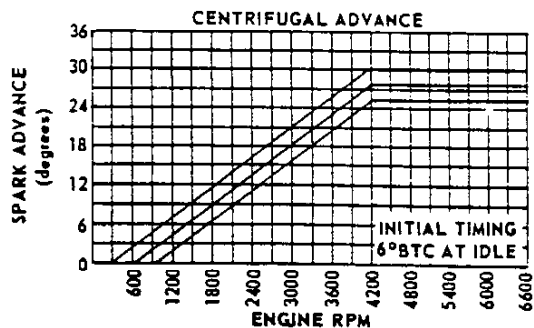

110 HORSEPOWER ENGINE

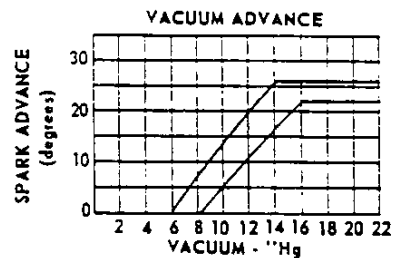
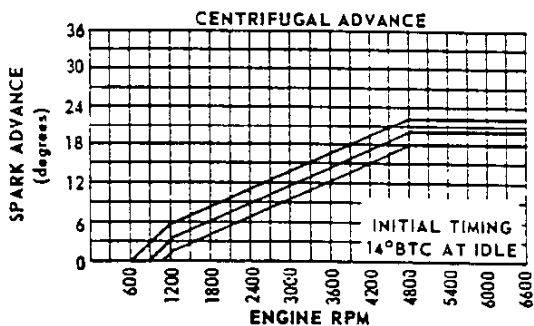

CLUTCHES

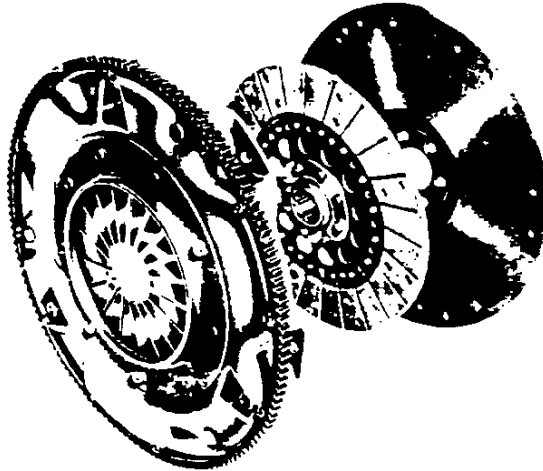

ENGINE	Regular Production	10100 & 10500		10700								
	RPO					L62		L63		L87		
Clutch Type	3-Spd		4-Spd		3-Spd		4-Spd		3-Spd		4-Spd	
Clutch cover and press. plate	Eff. plate load, lb	1250-1450		1275-1475		1250-1450		1275-1475				
	Press. plate mat'l	Cast iron		Nodular iron		Cast iron		Nodular iron				
	Clutch spring type	Diaphragm with bent finger design										
	Clutch spring mat'l	HR spring steel										
	Ring gear	Mat'l	HR steel									
		No. of teeth	147									
		PD	12.25									
Attach.		Welded to clutch cover										
Driven plate	Type	Single dry disc										
	Cushions	Flat spring steel between rings										
	Friction rings	OD	8.0		9.12		8.0		9.12			
		ID	6.0		6.12		6.0		6.12			
	Total area (sq. in.)	44.0		71.8		44.0		71.8				
	Mat'l	Woven type asbestos										
Bearings	Release	Type	Single roll ball									
		Lub.	None required, prepacked									
	Pilot	Type	Bronze bushing									
		Lub.	None, sintered and oil impregnated									
Controls	Clutch fork	Drop forged steel, pivot mounted on ball										
	Pedal mounting	Pendent from brace on dash										
Clutch housing material	Aluminum alloy											

TRANSMISSIONS

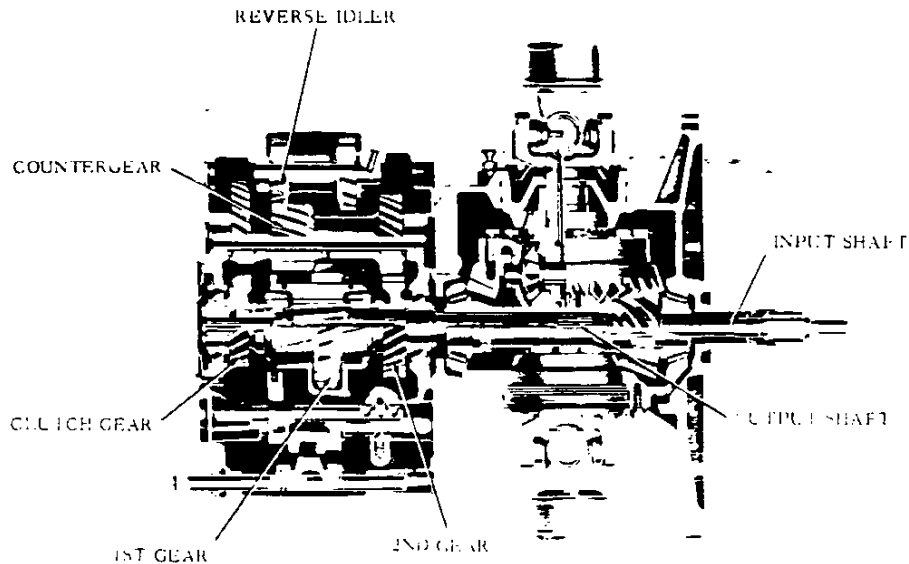

TRANSAXLE WITH 3-SPEED TRANSMISSION

3- AND 4-SPEED (RPO M20)

ENGINE	Regular Production	10100, 10500	10700				10100, 10500	10700					
	RPO			L62	L63	L87			L62	L63	L87		
Transmission type		3-Speed						4-Speed					
Case material		Cast iron alloy											
Gear-shift	Type	Remote											
	Control	Lever											
	Location	Floor											
Gears	Type	Helical					Helical except spur for reverse						
	Material	Forged steel, hardened											
	Synchronization	2nd and 3rd					All forward gears						
	Constant mesh gears	2nd and 3rd					All forward gears						
	Sliding gears	1st and Reverse					Reverse						
	Ratios	First	3.22					3.20					
		Second	1.84					2.19					
		Third	1.00					1.44					
Fourth		---					1.00						
Reverse		3.22					3.66						
Lubricant	Type	Meeting Military Spec. MIL-L-2105-B											
	Capacity (pts)	3.1					3.6						

AUTOMATIC TRANSMISSION - RPO M35

GENERAL DATA

Type ----- Automatic hydraulic torque converter with planetary gear system for low and reverse

Selector lever

Location ----- Instrument panel

Operation ----- Actuates manual valve in hydraulic control system

Quadrant positions ----- L-D-N-R

Method of cooling ----- Cooling shroud welded to pump housing

Flywheel ----- Ring gear welded to converter housing

HYDRAULIC CONTROLS

Manual valve type ----- Spool

Pressure regulator valve type ----- Spool

Pressure range, psi @ idle

Drive

Minimum and maximum ----- 37.0 to 45.0

Low

Minimum and maximum ----- 37.0 to 45.0

Reverse

Minimum and maximum ----- 70.3 to 86.0

CONVERTER ASSEMBLY

Type ----- Three element

Pump

Description ----- Multi-vane sheet steel construction rigid in converter housing

Turbine

Description ----- Multi-vane sheet steel construction supported in converter housing

Stator

Description ----- Aluminum air foil supported on stationary sleeve by an over-running clutch

Stall torque ratio ----- 2.60:1

Diameter (nominal) ----- 10.0

PLANETARY GEAR SET

Type ----- Compound planetary

Range

Drive ----- 1.82:1 to 1.0:1.0

Low ----- 1.82:1

Reverse ----- 1.82:1

Low band ----- Three linked circular segments

Low band servo ----- Piston with release spring and inner cushion spring

CASE

Material ----- Aluminum

OUTPUT SHAFT RPM (VEHICLE SPEED MPH)

N/V factor ----- 45.8

Upshift

Closed throttle ----- 677(15)

Detent touch ----- 1809(40)

Full detent ----- 2230(49)

Downshift

Closed throttle ----- 606(13)

Detent touch ----- 1298(28)

Full detent ----- 2055(45)

HIGH CLUTCH

Type ----- Multi-disc

Drive plates

Description ----- Waved steel with bonded organic facings

Number ----- 2

Driven plates

Description ----- Flat steel

Number ----- 3

REVERSE CLUTCH

Type ----- Multi-disc

Drive plates

Description ----- Flat steel with bonded organic facings

Number ----- 3

Driven plates

Description ----- Waved steel

Number ----- 3

TORQUE MULTIPLICATION

Maximum overall ratio ----- 4.73:1

Low and reverse ----- 4.73:1 to 1.82:1

LUBRICANT

Type ----- A, suffix A

Capacity (pts.)

Dry ----- 13

Refill ----- 6

GOVERNOR

Type ----- Centrifugal

Operation ----- Regulates oil pressure to automatic shift control valve

Drive ----- Transmission output shaft

Location ----- External, upper left side of case

OIL PUMPS

Type ----- Internal-external gear

Number ----- Two, front and rear

Function ----- To supply pressure

Front pump

Drive ----- Converter pump

Function ----- Supply main system pressure at low vehicle speeds

Rear pump

Drive ----- Output shaft

Function ----- Supply main system pressure at high vehicle speeds and during push starts

AMA Specifications – Passenger Car

The information contained herein is prepared, distributed by, and is solely the responsibility of the automobile manufacturing company to whose products it relates. Questions concerning these specifications should be directed to the manufacturer whose address is shown below. This uniform specification form was developed by the automobile manufacturing companies under the auspices of the Automobile Manufacturers Association.

MANUFACTURER	Chevrolet Motor Division	CAR NAME	CORVAIR
	General Motors Corporation		164 Cu. In. 6-Cyl.
MAILING ADDRESS	Owner Relations Service	MODEL YEAR	1965
	General Motors Bldg. Detroit 2, Michigan		ISSUED: 9-28
		REVISED (e)	

NOTES:

- The Specifications herein are those in effect at date of compilation and are subject to change without notice by the manufacturer
- UNLESS OTHERWISE INDICATED:
 - Specifications apply to standard models without optional equipment. Significant deviations are noted.
 - Nominal design dimensions are used throughout these specifications.

TABLE OF CONTENTS

General Specifications 1	Drive Units 15	Rear Suspension 21	Weights
Engine - Mechanical 2	Brakes 18	Station Wagon 1a	Index
Electrical 10	Front Suspension & Steering . . 19		

BODY—TYPES AND STYLE NAMES—

Body type, number of passenger & style names; use manufacturer code for series & body style.

500 Series

- 10137 2-Door Sport Coupe, 5-Passenger
- 10139 4-Door Sport Sedan, 6-Passenger

Monza

- 10537 2-Door Sport Coupe, 4-Passenger
- 10567 2-Door Convertible, 4-Passenger
- 10539 4-Door Sport Sedan, 5-Passenger

Corsa

- 10737 2-Door Sport Coupe, 4-Passenger
- 10767 2-Door Convertible, 4-Passenger

AMA Specifications — Passenger Car

MAKE OF CAR CORVAIR MODEL YEAR 1965 DATE ISSUED 9-28-64 REVISED(a) _____

GENERAL SPECIFICATIONS

(All dimensions in inches unless otherwise indicated)

MODEL	Additional Information Page No.:	10100 & 10500		10700		
		95 HP	110 HP	140 HP*	180 HP	
Wheelbase (L101)	23	108.0				
Tread	Front (W101)	55.0				
	Rear (W102)	57.2				
Maximum Overall Dimensions	Length (L103)	183.3				
	Width (W103)	69.7				
	Height (H101)	Sp. Sed. 51.2, Coupe 51.3, Conv. 51.5				
Transmission— (Specify trade name - opt., not available)	Manual	Synchromesh: 3-speed std., 4-speed optional				
	Overdrive	NA				
	Automatic	Optional		NA (a)	NA	
Axle ratio	Manual	3	3.27	3.27	3.55	3.55
		4	3.27	3.27	3.55	3.55
	Overdrive	NA				
	Automatic	3.27	3.55	NA (b)	NA	
Tire size	18	6.50 x 13				
Engine	Type, no. cyl., valve arr.	2 Horizontal opposed 6-cyl., OHV air cooled				
	Fuel system (Carb., other)	8 Carburetor				
	Bore and stroke	2 3.4375 x 2.94				
	Piston displ., cu.in.	2 164				
	Std. compression ratio	2	8.25:1	9.25:1	9.25:1	8.25:1
	Max. bhp at engine rpm	2	95 @ 3600	110 @ 4400	140 @ 5200	180 @ 4000
	Max. torque at rpm	2	154 @ 2400	160 @ 2800	160 @ 3600	265 @ 3200

* Also optional with 10100 & 10500

(a) Powerglide optional only when engine is optional (L63) for 10100 & 500

(b) When engine is optional for 10100 & 10500, 3.55

MAKE OF CAR CORVAIR MODEL YEAR 1965 DATE ISSUED 9-28-64 REVISED (•)

GENERAL SPECIFICATIONS — DIMENSIONS

(All dimensions in inches unless otherwise indicated)
(Supplemental data available on request)

MODEL	Ref. No.	SEDANS		COUPES		CONVERT
		Bench	Bucket	Bench	Bucket	IBLES
FRONT COMPARTMENT						
Shoulder room	W3			54.7		
Max. eff. leg room - accelerator	L34	41.1	40.9	41.1		40.9
Effective head room	H61		37.6	37.5	37.7	38.5
H Point to Heel point	H30		7.4		7.6	7.4
Upper body opening to ground	H50		46.9	41.9	46.9	46.9

REAR COMPARTMENT

Shoulder room	W4		54.3		52.7	47.9
H Point coupe distance	L50	32.0	32.2		28.6	28.8
Minimum effective leg room	L51	35.4	34.6	30.8		30.5
Effective head room	H63	36.4	36.6		36.4	38.2

STATION WAGON—THIRD SEAT

Shoulder room	W85					
Effective leg room	L86				None	
Effective head room	H86					

LUGGAGE COMPARTMENT

Usable luggage capacity (See instr.)	V1			7.0		
Liftover height	H195			27.6		
Position of spare tire storage					Horizontal, engine compartment	
Method of holding lid open					Torsion rod, counterbalanced	

STATION WAGON—CARGO SPACE

Minimum distance between wheel houses at floor level	W201					
Rear end opening width at belt	W204					
Floor length from back of front seat at floor level to inside of closed tail gate	L202					
Minimum horizontal distance from top rear of front seat back to inside of tail gate at belt	L204				None	
Maximum height - floor covering to headlining at centerline of rear axle	H201					
Maximum height of rear opening - tail and lift gates open	H202					
Cargo volume index (cu.ft.)	$\frac{W4 \times L204 \times H201}{1728}$			V2		

AMA Specifications—Passenger Car

MAKE OF CAR	CORVALL	MODEL YEAR	1965	DATE ISSUED	9-28-64	REVISED (*)
MODEL	10100 & 10500			10700		
	95 HP	110 HP	140 HP*	180 HP		

ENGINE—GENERAL

Type, no. cyls., valve arr.		Horizontal opposed 6-cylinder OHV			
Bore and stroke (nominal)		3.4375 x 2.94			
Piston displacement, cu. in.		164			
Bore spacing (C/L to C/L)		4.85			
No. system front to rear	L. Bank	5-4-2			
	R. Bank	5-3-1			
Firing order		1-4-5-2-3-6			
Compress. ratio (nominal)		8.25:1	9.25:1	9.25:1	8.25:1
Cylinder Head Material		Cast aluminum			
Cylinder Block Material		Cast aluminum			
Cylinder Sleeve—Wet, dry, none		None			
Number of mounting points	Front	Two			
	Rear	One			
Engine installation angle		28°33'			
Taxable horsepower Dia. 2 x No. Cyl. 2.5		28.4			
Published max. bhp* @ eng. RPM		95 @ 3600	110 @ 4400	140 @ 5200	180 @ 4000
Published max. torque* (lb. ft. @ RPM)		154 @ 2400	160 @ 2800	160 @ 3600	265 @ 3200
Recommended fuel Regular - premium		Regular		Premium	
Idle speed (spec. neutral or drive)	Manual	500 in neutral		600 in neutral	
	Automatic	500 in drive			

ENGINE—PISTONS

Material		Cast aluminum alloy		
Description and finish		Flat head - slipper skirt		
Weight (piston only) oz.		15.50		
Clearance (limits)	Top land	.021 - .040		
	Skirt	Top	.0011 - .0017 (a)	
		Bottom		
Ring groove depth	No. 1 ring	.1930 - .1990		
	No. 2 ring	.1930 - .1990		
	No. 3 ring	.1860 - .1925		
	No. 4 ring	None		

*Max. bhp (brake horsepower) and max. torque corrected to 60° F and 29.92 in. Hg atmospheric pressure.

(a) - Measured 2.01 from top of piston

180 - Also optional with 10100 & 10500

AMA Specifications – Passenger Car

MAKE OF CAR CORVAIR MODEL YEAR 1965 DATE ISSUED 9-28-64 REVISED (e)

POWER TEAMS

(Indicate whether standard or optional)

MODEL AVAILABILITY	ENGINE					TRANSMISSION	AXLE RATIO ** (Std. first)		
	Displ. cu. in.	Carburetor	Compr. Ratio	BHP @ RPM	Torque @ RPM		"A"	"B"	"C"
10100 10500	164 95 hp	Two; 1-Bbl Down- draft	8.25:1	95 @ 3600	154 @ 2400	3-Speed 4-Speed* Powerglide*	3.27:1	3.55:1	--
10700 (Base) 10100-500 (Optional)	164 140 hp	Four; 1-Bbl Down- draft	9.25:1	140 @ 5200	160 @ 3600	3-Speed 4-Speed* Powerglide*‡	3.55:1	3.27:1	-- --
10100 10500	164 110 hp (opt)	Two; 1-Bbl Down- draft	9.25:1	110 @ 4400	160 @ 2800	3-Speed 4-Speed* Powerglide*	3.27:1	3.55:1	-- --
10700	164 150 hp (opt)	One; 1-Bbl Side- draft	8.25:1	180 @ 4000	265 @ 3200	3-Speed 4-Speed*	--	--	3.55 (Std)
<p>A - General Purpose (Standard) B - Special Purpose or Mountain C - High Performance * - Optional ** - Positraction axle available in all ratios shown ‡ - 10100-500 Models only</p>									

AMA Specifications - Passenger Car

MAKE OF CAR	CORVAIR	MODEL YEAR	1965	DATE ISSUED	9-28-64	REVISED	#
MODEL	10100 & 10500	10700	95 HP	110 HP	140 HP *	180 HP	

ENGINE-RINGS

Function (top to bottom)	No. 1, oil or comp.	Compression
	No. 2, oil or comp.	Compression
	No. 3, oil or comp.	Oil
	No. 4, oil or comp.	None
Compression	Description - material, type, coating, etc.	Cast alloy iron - inside bevel or counterbore Upper ring - chrome plated# Lower ring - wear resistant coating
	Width	.0620-.0625
	Gap	.010-.020
Oil	Description - material, type, coating, etc.	Multi-piece (2 rails and one spacer expander); Rails - chrome plated O.D. Spacer expander - steel
	Width	.1215-.1255 assembled
	Gap	.015-.055
Expanders		In oil ring assembly

ENGINE-PISTON PINS

Material	Chromium steel		
Length	2.630-2.650		
Diameter	.7999-.8002		
Type	Locked in rod, in piston, floating, etc.	Locked in rod	
	Bushing	In rod or piston	None
		Material	None
Clearance	In piston	.00015-.00025	
	In rod		
Direction & amount offset in piston	Major thrust side .055-.065		

ENGINE-CONNECTING RODS

Material	Drop forged steel	
Weight (oz.)	15.20	
Length (center to center)	4.719-4.721	
Bearing	Material & Type	Premium aluminum
	Overall length	.649
	Clearance (limits)	.0007-.0028
	End play	.005-.010

- 140 HP & 180 HP - Upper ring is high strength ductile iron and molybdenum casting
 * - Also optional with 10100 & 10500

AMA Specifications—Passenger Car

MAKE OF CAR	CORVAIR	MODEL YEAR	1965	DATE ISSUED	9-28-64	REVISED (*)
MODEL	95 HP	10100 & 10500	110 HP	10700	140 HP*	180 HP

ENGINE—CRANKSHAFT

Material		Forged alloy steel		
Vibration damper type		None #	Rubber mounted inertia damper	
End thrust taken by bearing (No.)		#1 (at rear of engine)		
Crankshaft end play		.002 - .006		
Main bearing	Material & type		Premium aluminum	
	Clearance		.0012 - .0037	
	Journal dia. and bearing overall length	No. 1	2.1008 x .752	
		No. 2	2.1008 x .752	
		No. 3	2.1018 x .752	
		No. 4	2.1018 x .752	
		No. 5	None	
		No. 6	None	
No. 7		None		
Dir. & amt. cyl. offset		None		
Crankpin journal diameter		1.799 - 1.800		

ENGINE—CAMSHAFT

Location		Directly below crankshaft	
Material		Cast alloy iron	
Bearings	Material	No inserts, aluminum crankcase	
	Number	machined for bearing surface	
Type of Drive	Gear or chain		Gear
	Crankshaft gear or sprocket material		Steel
	Camshaft gear or sprocket material		Cast aluminum
	Timing chain	No. of links	None
Width			
Pitch			

ENGINE—VALVE SYSTEM

Hydraulic lifters (Std, opt, NA)		Standard	
Valve rotator, type (Intake, exhaust)		None	
Rocker ratio		1.57:1	1.50:1
Operating taper clearance (Indicate hot or cold)	Intake	Zero	
	Exhaust	Zero	
Timing marks on flywheel, damper, other		Crankshaft pulley	Harmonic balancer

- Rubber mounted damper used with Powerglide

(Continued)

* - Also optional with 10100 & 10500

AMA Specifications—Passenger Car

MAKE OF CAR CORVAIR MODEL YEAR 1965 DATE ISSUED 9-23-64 REVISED (*)

	10100 & 10500	10700
MODEL	95 HP	110 HP
	140 HP*	180 HP

ENGINE—VALVE SYSTEM (cont.)

Timing	Intake	Opens (°BTC)	14°	55°	82°	
		Closes (°ABC)	22°	105°	110°	
		Duration - deg.	312°	340°	372°	
	Exhaust		Opens (°BBC)	-9°	97°	110°
			Closes (°ATC)	51°	63°	70°
			Duration - deg.	312°	340°	360°
	Valve opening overlap	22°	118°	152°		
Intake	Material	High alloy steel - aluminized face				
	Overall length	4.489-4.509	4.546-4.571	4.481-4.509		
	Actual overall head dia.	1.335-1.345	1.715-1.725	1.335-1.345		
	Angle of seat & face	45° 'seat' 44° 'face'				
	Seat insert material	Sintered alloy iron				
	Stem diameter	.3414-.3422				
	Stem to guide clearance	.0010-.0028				
	Lift (@ zero lash)	±0.30	.3907	.3741		
	Outer spring press. and length	Valve closed (lb. @ in.)	78-86 @ 1.66			
		Valve open (lb. @ in.)	170-180 @ 1.26			
	Inner spring press. and length	Valve closed (lb. @ in.)	Spring damper			
		Valve open (lb. @ in.)	Spring damper			
Exhaust	Material	High alloy steel - cobalt based alloy face			(a)	
	Overall length	4.494-4.514	4.493-4.518	4.494-4.514		
	Actual overall head dia.	1.235-1.245	1.355-1.365	1.235-1.245		
	Angle of seat & face	45° 'seat' 44° 'face'				
	Seat insert material	Cast chromium steel alloy (b)				
	Stem diameter	.3407-.3418				
	Stem to guide clearance	.0014-.0035				
	Lift (@ zero lash)	±0.30	.3907	.3741		
	Outer spring press. and length	Valve closed (lb. @ in.)	78-86 @ 1.66			
		Valve open (lb. @ in.)	170-180 @ 1.26			
	Inner spring press. and length	Valve closed (lb. @ in.)	Spring damper			
		Valve open (lb. @ in.)	Spring damper			

ENGINE—LUBRICATION SYSTEM

Type of lubrication (splash, pressure, nozzle)	Main bearings	Pressure
	Connecting rods	Pressure
	Piston pins	Splash
	Camshaft bearings	Pressure
	Tappets	Pressure
	Timing gear or chain	Main & cam front bearing throw off
	Cylinder walls	Conn. rod bearing throw off

* - Also optional with 10100 & 10500

(Continued)

- (a) - Stem - Silicon & chromium alloy steel;
Head & Neck - Superalloy (nimonic 80A);
- (b) - Cast nickel steel alloy on 140 HP

AMA Specifications - Passenger Car

MAKE OF CAR FORD V8 MODEL YEAR 1965 DATE ISSUED 9-18-64 REVISED ^(*)
10100 & 10500 10700

MODEL 95 HP 110 HP 140 HP* 180 HP

ENGINE-LUBRICATION SYSTEM (cont.)

Oil pump type	Gear
Normal oil pressure (lb. @ engine rpm)	30 PSI @ 2000
Oil pressure sending unit (elect. or mech.)	Electric
Oil intake (floating, stationary)	Stationary
Oil filter system (full flow, partial, orner)	Full flow
Filter replacement (element, complete)	Complete
Capacity of crankcase, less filter-refill (qt.)	

Oil grade recommended (SAE viscosity and temperature range):
 32° F and Above ----- SAE30
 10° F to 32° F ----- SAE10W
 Below 10° F ----- SAE5W-20
 Note: Always use SAE30 if daytime temp. is above 60° F

Engine Service Requirement (MM, MS, etc.)

ENGINE-EXHAUST SYSTEM

Type (single, single with cross-over, dual, other)	Single with crossover	Dual	Single with crossover
Muffler No. & type (reverse flow, straight thru, separate resonator)	One, reverse flow	Two, reverse flow	One, reverse flow
Exhaust pipe dia. (O.D. Branch wall thickness)	1.375 x .067 - .081	-	1.375 x .089
	Main 1.875 x .067 - .081	1.625 x .067 - .081	1.875 x .089
Tail pipe diameter (O.D. & wall thickness)	1.75 x .042 - .052		2.50 x .047

ENGINE-CRANKCASE VENTILATION SYSTEM

Type (ventilates to atmos., induction system, other)	Standard	Ventilates to induction system
	Optional	
Make and model		
Location	Tubing and hoses from underside of air cleaner to rear of engine shrouding	
Energy source (manifold vacuum, carburetor air stream, other)	Manifold vacuum and/or carburetor air stream	
Control unit	Variable orifice	
Discharges (to intake manifold, carb. air intake, air cleaner intake, other)	Carburetor air and compressor inlet	
Complete system	Carburetor air cleaner	
Flame arrestor (screen, check valve, other)	Fixed orifice	

* - Also optional with 10100 & 10500
 ** - SAE5W-30 can be used as an alternate for 5W; 5W-20 or 10W-30.

AMA Specifications— Passenger Car

MAKE OF CAR CORVAIR MODEL YEAR 1965 DATE ISSUED 9-28-64 REVISED ^(*)

	10100 & 10500	10700
MODEL	95 HP	110 HP
	140 HP#	180 HP

ENGINE—FUEL SYSTEM

(See Supplement to Page 8 for Details of Fuel Injection, Supercharger, etc. if used)

Induction type: Carburetor, fuel injection, supercharger.		Carburetor	Supercharger(A)
Fuel Tank	Capacity (gals.)	14	
	Filler location	Left front fender crown	
Fuel Pump	Type (elec. or mech.)	Mechanical	
	Locations	Mounted on engine rear housing	
	Pressure range	5.50-6.75 PSI	
Vacuum booster (std., optional, none)		None	
Fuel Filter	Type	Fine mesh plastic strainer in gas tank	
	Locations		(B)
Carburetor	Choke type	Automatic	
	Intake manifold heat control (exhaust or water)	Carburetors, manifold and intake air warmed by recirculating engine cooling air	(A)
	Air clnr. type	Standard Oil wetted paper	
	Optional	One pre oil-bath air cleaner	

CARBURETOR SUPPLEMENTARY INFORMATION

Model Usage	Engine Displ.	Transmission	Carburetors		No. Used and Type	Barrel Size
			Make	Model		
10100 10500	164 95 hp	3-Speed & 4-Speed Powerglide	Rochester	7025023	Two*	1.25
10100 10500	164 110 hp	3-Speed & 4-Speed Powerglide	Rochester	7025024	Two*	1.25
10700	164 140 hp	3-Speed 4-Speed	Rochester	7025023(P) 7025226(S)	Four**	1.25 Primary & Secondary
10700	164 180 hp	3-Speed 4-Speed	Carter	3856713	One***	1.50
<p>* - One for each cylinder bank, single barrel downdraft ** - Two for each cylinder bank, single barrel downdraft *** - Single barrel (triple venturi) sidedraft (A) - See supplement to page 8 for detail (B) - Throw-away in line (paper element) located between fuel pump and carburetor</p>						

- Also optional with 10100 & 10500

AMA Specifications – Passenger Car Supplement to Page

MAKE OF CAR CORVAIR MODEL YEAR 1965 DATE ISSUED 9-28-64 REVISED (*)

SUPPLEMENTARY INFORMATION

MODEL Corvair Corsa 10737 & 10767

Super charger (Optional)

Type ----- Turbo-Supercharger
(Turbine Driven Compressor)

Make ----- Thompson

Turbine ----- Single Stage, In-Flow Type
Material ----- High Temperature Cobalt Base Alloy
Diameter (in.) ----- 2.97
Blades ----- 11, Equally Spaced
Drive ----- Engine Exhaust Gases

Compressor ----- Centrifugal Impeller
Material ----- Die Cast Aluminum Alloy
Diameter (in.) ----- 3.00
Blades ----- 14, Equally Spaced
Drive ----- Solid Shaft from Turbine

Bearing ----- One Piece Floating Bushing
Material ----- Aluminum Alloy
Lubrication ----- Engine Oil, Full Pressure

AMA Specifications – Passenger Car

MAKE OF CAR CORVAIR MODEL YEAR 1965 DATE ISSUED 9-28-64 REVISION (*)

MODEL _____

ENGINE—COOLING SYSTEM

Type system (pressure, pressure vented, atmospheric, other)			
Radiator cap relief valve pressure			
Circulation thermostat	Type (choke, bypass)		
	Starts to open at (°F)		
Water pump	Type (centrifugal, other)		
	GPM @ 1000 pump rpm		
	Number of pumps	Refer to	
	Drive (V-belt, other)		
Bearing type			
By-pass recirculation type (internal, external)		Supplement	
Radiator core type (cellular, tube and fin, other)			
Cooling system capacity	With heater (qt.)	Page 9	
	Without heater (qt.)		
	Opt. equipment-specify (qt.)		
Water jackets full length of cylinder (yes, no)		for type	
Water all around cylinder (yes, no)			
Radiator hose	Lower	Number and type (molded, straight)	of cooling
		Inside diameter	
	Upper	Number and type (molded, straight)	
		Inside diameter	
	By-pass	Number and type (molded, straight)	
		Inside diameter	
Fan	Number of blades & Spacing		
	Diameter		
	Ratio—fan to crankshaft rev.		
	Fan cutout type		
	Bearing type		
*Drive belts (indicate belt used by letter)	Fan		
	Generator		
	Water Pump		
	Power Steering		
Air Conditioning			

* Drive Belt Dimensions	
Angle of V	
Nominal length (SAE)	
Width	

AMA Specifications – Passenger Car Supplement to Page 9

MAKE OF CAR CORVAIR MODEL YEAR 1965 DATE ISSUED 9-28-64 REVISION (*)

SUPPLEMENTARY INFORMATION

MODEL 10100, 10500 & 10700

ENGINE - COOLING SYSTEM

Type		Air, forced supply by centrifugal blower
Engine Shrouding		Engine enclosed in sheet metal to direct cooling air over fins on outside of engine cylinders, cylinder head castings and crankcase
Engine Blower	Type	Centrifugal
	Location	Mounted horizontally on top center of engine
	Material	Magnesium
	Diameter	11.20
	Number of vanes	11
	Driven by	"V" belt
	Air flow	1460 cfm @ 4000 engine RPM
	Pulley (PD)	4.1875
	Ratio-fan to crankshaft	1.58:1
	Bearing	Permanently lubricated ball bearing
Drive Belt	Type	"V"
	Pitch length	55.74
	Width	.380
	Angle of "V"	40°
Air Thermo-stats	Function; number	Two; regulates air flow control doors
	Type	Bellows
	Location	Lower part of plenum under front cyls.
	Bellows start to open at	205° (approximately)

AMA Specifications – Passenger Car

MAKE OF CAR	CORVAIR	MODEL YEAR	1965	DATE ISSUED	9-28-64	REVISED	(*)
MODEL	10100 & 10500	95 HP	110 HP	140 HP*	170 HP	130 HP	

ELECTRICAL—SUPPLY SYSTEM

Battery	Make and Model	Delco-Remy #1980007					
	Voltage Rtg. & Total Plates	12 Volts - 34 Plates					
	SAE Designation & Amp Hr. Rtg.	44 Amp Hr @ 20 Hr Rate					
	Location	Left side of engine compartment					
	Terminal grounded	Negative					
Generator	Make	Delco-Remy					
	Model	#1100630					
	Type	Diode rectified					
	Ratio—Gen. to Cr/s rev.	2.3:1					
	Gen. cut-in (hot)—engine rpm						
Regulator	Make	Delco-Remy					
	Model	#1110515					
	Type	Vibrator					
	Cutout relay	Closing voltage @ generator rpm	None				
		Reverse current to open					
	Regulated	Voltage	13.8-14.8 @ 85° F				
		Current					
	Voltage test conditions	Temperature	Operating				
Load		3-8 Amperes					
Other		None					

ELECTRICAL—STARTING SYSTEM

Starting motor	Make	Delco-Remy				
	Model	#1108306				
	Rotation (drive end view)	Clockwise				
	Engine cranking speed					
	Test conditions	Operating temperature				
	Lock test	Amps				
		Volts				
Torque (lb. ft.)						
No load test	Amps	5.9				
	Volts	10.6				
	RPM (min.)	7675				
Motor control	Switch (solenoid, manual)	Solenoid				
	Starting procedure	<p>SYNCHROMESH - Place gear shift in neutral and depress clutch to floor.</p> <p>POWERGLIDE - Place control lever in N position.</p> <p>INITIAL START - Press accelerator pedal to floor to set automatic choke then release. Turn ignition to START and release as soon as engine starts.</p>				

* - Also optional with 10100 & 10500

(Continued)

AMA Specifications - Passenger Car

MAKE OF CAR	CORVAIR	MODEL YEAR	1965	DATE ISSUED	9-28-64	REVISED (*)
MODEL	10100 & 10500	10700	95 HP (Std)	95 HP (P/Std)	110 HP	140 HP*
						180 HP

ELECTRICAL-STARTING SYSTEM (cont.)

Motor Drive	Engagement type	Positive shift solenoid
	Pinion meshes (front, rear)	Rear
	Number of teeth	9
	Flywheel	147
	Flywheel tooth face width	363-387

ELECTRICAL-IGNITION SYSTEM

Coil	Make	Delco-Remy					
	Model	#1115200					
	Amps	Engine stopped	4.0				
		Engine idling	1.8				
Distributor	Make	Delco-Remy					
	Model	#1110310	#1110311	#1110319	#1110330	#11103	
	Cent'fgal adv. in crankshaft degrees @ engine rpm (nominal)	Start (rpm)	700	1700	800	800	4000
		Intermediate points deg. @ rpm					
		Max deg. @ rpm	28 @ 4200	20 @ 4200	20 @ 4800	18 @ 2800	18 @ 49
	Vacuum adv. in crankshaft in. Hg. (nominal)	Start (in Hg)	6.00	7.00	7.00	6.00	(a)
		Intermediate points, deg @ in Hg					
		Max. deg. in. Hg.	24 @ 14	24 @ 15	24 @ 15	22 @ 14	(a)
		Breaker gap (in.)	.019				
		Cam angle (deg.)	31° - 34°				
	Breaker arm tension (oz.)	19-23 oz					
Timing	Crankshaft deg. @ rpm.	6 @ 500	14 @ 500	14 @ 600	18 @ 650	24 @ 800	
	Mark location	Crb/sft pulley Harmonic balancer					
	Cylinder numbering system (see page 2)	Left bank 6-4-2 Right bank 5-3-1					
	Firing order (see page 2)	1-4-5-2-3-6					
Spark Plug	Make and model	AC46-FF		AC44-FF			
	Thread (mm)	14					
	Tightening torque (lb. ft.)	25					
	Gap	033-038		028-033			
Cable	Conductor type	Linen core impregnated with electrical conducting material					
	Insulation type	Rubber with neoprene jacket					
	Spark plug protector	Neoprene					

ELECTRICAL-SUPPRESSION

Locations & type	Non-metallic high tension ignition cables
------------------	---

* - Also optional with 10100 & 10500

(a) No vacuum advance - unit operates on positive pressure.

Manifold pressure begins - 0° @ 2 psi; max. pressure 12° @ 4-1/2 psi.

AMA Specifications - Passenger Car

MAKE OF CAR CORVAIR MODEL YEAR 1965 DATE ISSUED 1-13-64 REVISED 10

MODEL 1000 10100 10500 11700

ELECTRICAL—INSTRUMENTS AND SWITCHES

Speedometer Make AC
 Mileometer (yes, no) No With RPO 137

Charge indicator Fan Indicator Tail-Tale

~~Temperature indicator~~

Oil pressure indicator & Temp. indicator Tail-Tale



Fuel indicator—type Electric Gauge

Other Cig. Ltr., Clock (a), Tachometer (a) Temp. warn. buzzer; cvl. nd. Temp. gauge; intake manifold Press. ga.; clock; tach; cig. ltr.

Identify positions in order and circuits controlled	<p>ACCESSORY OFF ON START</p> 	<p>ACCESSORY - Accessories (ign. off) OFF - Off, locked ON - Ignition, batt., accessories START - Starter motor, spring return to ON</p>
---	--	---

Provision for illumination "

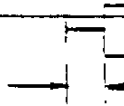
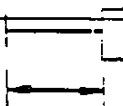
Location Instrument Panel to right of Steering Column

Identify positions and lamps controlled	 <p>1st Pos.</p>	 <p>2nd Pos.</p>	 <p>CW Rotation</p>	 <p>CCW Rotatic</p>
Main lighting switch	Instru. pnl. lamps, parking, tail and license lamps.	Instru. pnl. lamps, hdlps. tail and license lamps.	Instru. pnl. lamps, dim to off.	Instru. pnl. lamp off to bright; full CCW

Locations and lamps controlled	Toe panel - headlamp beam and indicator. Steering column - turn indicators & external lamps. Front door hinge pillars - dome &/or court. lps. (a) Brake pedal pendent - stop lamps. Parking brake lever - parking brake alarm (a). Glove compartment - glove compartment illumination (a).	Other light switches	Rotation, dome and/or courtesy lamps on.
--------------------------------	---	----------------------	--

Locations and devices controlled	Transmission - back-up lamps (a). Instrument cluster to left of stg. column - w/s wiper and washer Instrument cluster to right of steering column - heater controls. Left of steering column, below instrument panel - folding top motor (a). Center of instrument panel - radio (a). Instrument cluster to right of steering column - Powerglide (a).	Other switches	
----------------------------------	---	----------------	--

Windshield wiper	Make	Delco	
	Type	Electric, single-speed (a)	
	Vacuum booster provision	None	
Washer provision	Type	None (a)	
	Number used	One	Two
Horn	Type	Vibrator	
	Amp draw (each)	8.0-11.0 @ 12.5V	

(a) - OPTIONAL EQUIPMENT: Clock 10100 & 500; parking brake alarm; courtesy lamps except convertibles (door jam switches included on 10100); glove compartment lamp 10100; tachometer 10100 & 10500; W/S wiper (two-speed including washer); W/S washer for single-speed; radio; back-up lamps 10100; folding top motor. Form Rev. 3-6
 Powerglide 10100 & 10500 (NA 10700).

AMA Specifications — Passenger Car

MAKE OF CAR CORVAIR MODEL YEAR 1965 DATE ISSUED 9-13-64 REVISED NA

MODEL 10000 10100 10500 10700

ELECTRICAL—LAMP BULBS

Give quantity used and trade number, e.g., Headlamp 2-5400 S. dual headlight 2-4001, 2-4002.

Headlamps & arrangement		Dual, horizontal: Outer, 2-4002; inner, 2-4001		
Headlamp beam indicator		1-1445		
Parking		2-1157		
Tail		2-1157		
Stop		2-1157		
Direction signal	Front	2-1157		
	Rear	2-1157		
	Indicator	2-1445		
License plate		1-1155		
Oil pressure indicator and temp. ind.		1-1895		
Charge indicator and fan indicator		1-1895		
Instrument		4-1895		6-1895
Clock		Instrument lamps (a) Opt.		Instrument lamps Std
Radio		1-1893		

Indicate also whether the following lamp assemblies are standard equipment, optional, or NA.

Ignition lock		NA		
Back up	2-1156	Opt.	2-1156	Std
Dome			1-211	Std
Glove compartment	1-1895	Opt.	1-1895	Std
Prkg. brake signal			1-257	Opt
Luggage compartment			1-1003	Opt
Underhood			1-93	Opt
Courtesy	2-631	Opt.	2-631	Opt, except Std. convertible
Asst Ash tray			1-53	Opt
Heater controls			1-1445	Std
Traffic hazard ind.			1-1445	Opt
Spot lamp (portable)			1-4416	Opt
Auto. trans. position pattern			1-1445	Opt

(a) - With tachometer option, clock illuminated with 1-1895

AMA Specifications – Passenger Car

MAKE OF CAR CORVAIR MODEL YEAR 1965 DATE ISSUED 4-28-64 REVISED 0

MODEL 10000

ELECTRICAL—FUSE & CIRCUIT BREAKER DATA

Use trade number of fuse, e.g., SFE-10. Indicate circuit breaker by ampere capacity suffixed by letters "C.B.", e.g., 30 C.B. Where fuse or circuit breaker protects multiple circuits indicate first use by a letter and repeat the same letter for all units protected by the same fuse or circuit breaker, e.g., Parking lamp SFE-10 (a), Direction indicator same as (a).

Headlamp	15 CB	(a)	Fuel gauge	(d)
Headlamp beam indicator		(a)	Cigarette lighter	(b)
Parking lamp		(a)	Tachometer	(d)
Tail lamp	AGC 10	(b)	Fold. top motor	40 CB
Stop lamp		(b)	W/S wiper (two-speed)	14 CB & "(f)"
Direction indicator	AGC 3	(c)	Underhood lamp	SAE 4
License plate lamp		(b)	Luggage comp. lamp	(b)
Instrument lamp		(c)	Parking brake alarm	(d)
Ignition lamp		--	Air conditioning	Two AGC 15 in Line
Back up lamp		(d)	Asst. tray	(c)
Dome lamp		(b)		
Clock	AGC 10	(g)		
Clock lamp		(c)		
Radio	AGC 2.5	(e)		
Glove compartment lamp		(g)		
Heater				
10100	AGC 10.	(d)		
10500 & 10700	AGC 15	(d)		
W/S wiper (single-speed)	SAE 20	(f)		
Heater controls lamp		(c)		
Aut. trans. pos. pattern lamp		(c)		
Oil & temp. indicator		(d)		
Charge & fan indicator		(d)		
Temp. gauge & warning buzzer		(d)		
Courtesy lamps		(g)		

ELECTRICAL—LOCATION OF OUTSIDE LAMPS

Height above ground to center of bulb	Tail	Lowest	23.5	
		Highest	23.5	
	Stop		23.5	
		Backup	23.5	
	License, rear			
	Directional	Front	14.7	
		Rear	23.5	
Headlamp	Inside	23.0		
	Outside*	23.0		
Distance from C/L of car to center of bulb	Tail	Inside	24.7	
		Outside	24.7	
	Stop	24.7		
	Backup	17.9		
	License, rear			On Centerline
	Directional	Front	24.0	
		Rear	24.7	
	Headlamp	Inside	21.5	
		Outside*	27.9	

* If single headlamps are used enter here.

AMA Specifications - Passenger Car

MAKE OF CAR CORVAIR MODEL YEAR 1965 DATE ISSUED 9-28-64 REVISED ^(*)

Std. engine for 10100 & 10500 Opt. L62 1.63 Std. engine for 10700 Opt. L87

MODEL 10000 3-Speed and 4-Speed

DRIVE UNITS—CLUTCH (Manual Transmission)

Make & type	Chevrolet single drv disc, centrifugal	
Type pressure plate springs	Diaphragm bent finger design	
Effective plate pressure (lb.)	1250-1150	1275-1175
No. of clutch driven discs	One	
Clutch facing	Material <u>Woven type asbestos</u>	
	Outside & inside dia.	8.0 & 6.0 9.12 & 6.12
	Total eff. area (sq.in.)	44.0 71.8
	Thickness	.125 ea. .130 ea.
Engagement cushioning method	Flat spring steel between facings	
Release bearing	Type & method of lubrication	Single row ball, packed and sealed
Torsional damping	Methods: springs, friction material	None

DRIVE UNITS—TRANSMISSIONS

Manual (std. or opt.)	3-Speed Std., 4-Speed Optional	
Manual with overdrive (std. or opt.)	NA	
Automatic (std. or opt.)	Opt.	NA

DRIVE UNITS—MANUAL TRANSMISSION

Number of forward speeds		3-Speed	4-Speed	
Transmission ratios	In first	3.22	3.20	
	In second	1.84	2.19	
	In third	1.00	1.44	
	In fourth	---	1.00	
	In reverse	3.22	3.66	
Synchronous meshing, specify gears		2nd & 3rd	All forward gears	
Shift lever location		Floor		
Lubricant	Capacity (pt.)	3.1	3.6	
	Type recommended	For conventional axes, Military Spec. MIL-L-2105-B		
	SAE viscosity number	Summer	SAE 80	
		Winter	SAE 80	
Extreme cold		SAE 80		

MAKE OF CAR CORVAIR MODEL YEAR 1965 DATE ISSUED 9-28-64 REVISED (*)
 10100 & 10500 10700
 MODEL 10000 Sta. Engine L62 L63 Std. Engine 1.87

DRIVE UNITS—MANUAL TRANSMISSION WITH OVERDRIVE NA

For transmission data see manual transmission section

Type (planetary or other)	
Manual lockout (yes, no)	
Downshift accelerator control (yes, no)	
Minimum cut-in speed	
Overdrive Gear ratio	
Capacity (pt.) (Overdrive only)	
Separate filler (yes, no)	
Lubricant Type recommended	
SAE viscosity number	Summer
	Winter
	Ext. cold

DRIVE UNITS—AUTOMATIC TRANSMISSION NA

Trade name	<u>Powerglide</u>
Type describe	<u>Torque converter with planetary gears</u>
Method of Selection (Lever, Push Button or other)	<u>Lever</u>
Selector Pattern	<u>L-D-N-R</u>
List gear ratios Selector Pattern and indicate which are used in each selector position	<u>D - 1.82 & 1.0</u> <u>L & R - 1.82</u>
Max. upshift speeds—drive range	<u>49</u>
Max. kickdown speeds—drive range	<u>45</u>
Torque converter	Number of elements <u>3</u> Max. ratio at stall <u>2.60</u> Type of cooling (air, water) <u>None</u>
Lubricant	Capacity—refill (pt.) <u>6</u> Type recommended <u>A Suffix A</u>
Special transmission features	

DRIVE UNITS—PROPELLER SHAFT NA

Number used	
Type (exposed, torque tube)	
Outer diameter x length* x wall thickness	Manual transmission
	Overdrive transmission
	Automatic transmission

*Center to center of universal joints, or to centerline of rear attachment.

(Continued)

AMA Specifications – Passenger Car

MAKE OF CAR	CORVAIR	MODEL YEAR	1965	DATE ISSUED	2-28-64	REVISED (*)
MODEL	10000	Std. Engine for 10100 & 10500	L62	L63	Std. Engine for 10700	L87
				3-Speed and 4-Speed		

DRIVE UNITS—PROPELLER SHAFT (cont.)

Intermediate bearing	Type (plain, anti-friction)	
	Lubrication (fitting, prepack)	
Universal joints	Make	
	Number used	
	Type (ball and trunnion, cross, other)	
	Bearing	Type (plain, anti-friction)
Lubric. (fitting, prepack)		
Drive taken through (torque tube or arms, springs)		
Torque taken through (torque tube or arms, springs)		

DRIVE UNITS—REAR AXLE

Description (see instructions)	Component of transaxle system; straddle mounted hypoid gear with differential carrier rigidly mounted to engine.			
Limited Slip differential, type	Disc clutch (one side)			
Drive Pinion Offset	1.765			
No. of differential pinions	Two			
Gear ratios (Std. equip.)	Manual transmission	3.27	3.55	
	Overdrive transmission	NA		
	Automatic transmission	3.27	3.55	NA
Ring gear O.D. (std. ratio)	6.75			
Pinion adjustment (shim, other)	None			
Pinion bearing adj. (shim, other)	Shim			
Wheel bearing type	Two taper roller bearings for each wheel			
Lubricant	Capacity (pt.)	4.0		
	Type recommended	For conventional axles, Military Spec. MIL-L-2105-B		
	SAE viscosity number	Summer	SAE 80	
		Winter	SAE 80	
Extreme cold		SAE 80		

REAR AXLE RATIO TOOTH COMBINATIONS

(See page 3 for axle ratio usage)

Axle ratio		3.27	3.55
No. of teeth	Pinion	11	9
	Ring gear	36	32

MAKE OF CAR CORVETTE MODEL YEAR 1965 DATE ISSUED 9-23-64 REVISED •

MODEL 10000

DRIVE UNITS—WHEELS

Type & material	Short spoke disc steel
Size (size and flange type)	Std. 13 x 5.57
	Car.
Attachment	Type (bolt or stud) Bolt
	Circle diameter 4.75
	Number and size 5 hex nuts 7/16-10 UNF-2B

DRIVE UNITS—TIRES

Highway, tubeless, 2 ply, blackwall except as noted

Standard	Size & ply	6.50 x 13-4 PR
List option (below)	Type - Nylon, etc.	Rayon
Rev/mile at 50 mph.		
Inflation pressure (psi)	Front	15
	Rear	26

Optional tires - size and ply 6.50 x 13-4 PR rayon W/W (a) 6.50 x 13-4 PR nylon W/W or B/W.

BRAKES—SERVICE

Type (dual-servo, disc, balanced, etc.)	Dual-servo 4-wheel hydraulic
Self adjusting (std., opt., N.A.)	Std. reverse self-adjusting
Hydraulic system type (single, dual, etc.)	Single
Power brake make & type (remote, integral, etc.)	NA
Effective area (sq. in.)*	168.9
Gross lining area (sq. in.)**	168.9
Swear drum area (sq. in.)***	268.6
Percent brake effectiveness—front	46
Drum	Front 9.5
	Rear 9.5
Type and material	Composite: cast iron drum; steel web
Wheel cylinder bore	Front .875
	Rear .9375
Master cylinder bore	1.00
Available pedal travel	6.00
Line pressure at 100 lb. pedal load	783
Shoe clearance adjustment	Self-adjusting

* Excludes rivet holes, grooves, chamfers, etc. (Continued)
 ** Includes rivet holes, grooves, chamfers, etc.
 *** Total swear areas for four brakes
 Widest lining contact width for each brake x its drum circumference.

(a) 4-ply construction.

MAKE OF CAR FORD AIR MODEL YEAR 1965 DATE ISSUED 1-28-64 REVISED (6)

MODEL 10000

BRAKES—SERVICE (cont.)

Bonded or lined		Bonded	
Material		Molded asbestos	
Front Shoe	Size (length x width x thickness)	Front wheel	9.01 x 2.0 x .17
		Rear wheel	9.01 x 2.5 x .17
Segments per shoe		One	
Material		Molded asbestos	
Rear Shoe	Size (length x width x thickness)	Front wheel	9.75 x 2.0 x .20
		Rear wheel	9.75 x 2.5 x .20
Segments per shoe		One	

BRAKES—PARKING

Type or control	Mechanical		
Location of control	Under instrument panel to left of steering column		
Operates on	Rear service brakes		
If separate from service brakes	Type (internal or external)	---	
	Drum diameter	---	
	Lining size (length x width x thickness)	---	

FRAME or UNITIZED CONSTRUCTION

Type and description: Integral; Step down underbody floor, front and rear side rail type members, and front and rear end sheet metal components welded to body assembly.

SUSPENSION—GENERAL (See Supplemental page 19 for details on Air Suspension)*

Provision for car leveling		Front stabilizer bar	
Provision for brake dip control		Angle of front upper control arm	
Provision for acc. squat control		None	
Special provisions for car jacking		Front wheels: Place jack under body flange 2" aft of fwd edge of dr. Rear wheels: Place jack under body flange 2" fwd of l edge of wheel op	
Shock absorber front & rear	Type	Direct double-acting, hydraulic	
	Make	Delco	
	Piston dia.	1.00	
Other special features			

SUSPENSION—FRONT

Type and description: Independent - SLA type with coil spring and concentric shock absorber, and spherically-jointed steering knuckle for each wheel.

* Air Suspension:
Air spring type
Compressor data
type
make
drive ratio

Normal operating pressures
spring rates
leveling data

(Continued)

MAKE OF CAR CORVAIR MODEL YEAR 1965 DATE ISSUED 9-23-64 REVISED*

MODEL 10000 Except Convertibles Convertibles

SUSPENSION FRONT (cont.)

	Type	Coil RH helix	
	Material	Steel alloy	
Spring	Size (coil design height & I.D.; bar length x dia.)	6.42 & 3.453; 101.425 x .447	6.42 & 3.453; 101.581 x .465
	Spring rate (lb. per in.)	130	150
	Rate of wheel (lb. per in.)	1	78
	Design load (lb. @ design height)	300 @ 6.42	880 @ 6.42
Stabilizer	Type (link, linkless, frameless)	Linkless	
	Material & bar diameter	Steel .812	

STEERING

Manual (std., opt., NA)		Standard		
Power (std., opt., NA)		NA		
Adjustable steering wheel (tilt, swing, other)	Type and description	Telescoping steering column, driver adjustable		
	(std., opt., NA)	Optional		
Wheel diameter	Manual	16.0		
	Power	---		
Turning diameter	Outside front	Wall to wall (l. & r.)	37.5	
		Curb to curb (l. & r.)	35.2	
	Inside rear	Wall to wall (l. & r.)	19.2	
		Curb to curb (l. & r.)	20.1	
Outside wheel angle with inside wheel at 20°		18.4°		
Manual	Gear	Type	Semi-reversible, recirculating ball nut	
		Make	Saginaw	
	Ratios	Gear	18:1	
		Overall	23.3:1	
No. wheel turns		4.70		
Power	Type (coaxial, linkage, etc.)		---	
	Make		---	
	Gear	Type	---	
		Ratios	Gear	---
			Overall	---
	Pump driven by		---	
Number wheel turns		---		
Linkage	Type		Parallelogram	
	Location (front or rear of wheels, other)		Front of wheels	
	Drag link (trans. or longit.)		None	
	Tie rods (one or two)		Two	

(Continued)

AMA Specifications – Passenger Car

MAKE OF CAR CORVAIR MODEL YEAR 1965 DATE ISSUED 9-28-64 REVISED (*)

MODEL 10000

STEERING (cont.)

Inclination or camber (deg.)		6 to 7	
Steering Axis	Bearings (type)		
	Upper	Ball stud with non-metallic bearings	
	Lower	Ball stud with non-metallic bearings	
	Thrust	---	
Caster (deg.)		P 1-1/2 to P 2-1/2 (curb)	
Wheel alignment (range and preferred)	Camber (deg.)		
	P 1/2 to P 1-1/2 (curb)		
	Toe-in (outside tread-inches)		
		1/4 to 3/8 (total)	
Steering spindle & joint type		Steering knuckle w/spherical joints (b)	
Wheel spindle	Diameter	Inner bearing	1.2493 - 1.2498
		Outer bearing	.7492 - .7497
	Thread size		3/4 - 20 NEF-3 (modified)
	Bearing type		Taper roller

SUSPENSION—REAR (a)

Type and description		Fully independent, articulating link type		
Drive and torq. taken through (see page 17)		Control arms		
Spring	Type		Coil, RH helix	
	Material		Steel alloy	
	Size 3.78 & 4.20 , coil design height and I.D.; bar length & dia.)		7.78 & 4.20; 117.532 x .538	
	Spring rate (lb. per in.)		160	
	Rate at wheel (lb. per in.)		149	
	Design load (lb. at design height)		1070 @ 7.78	
	Mounting insulation type		Fibber insulated at upper mount	
	If leaf	No. of leaves		---
		Inserts	Type and size	---
			Material	---
Shackle (comp. or tens.)		---		
Stabilizer	Type (link, linkless, frameless)		None	
	Material		---	
Track bar type		None		

(a) Rear wheel alignment:

Camber (degrees) ----- N 1 to 0 (curb)
 Toe-in ----- 1/8 to 3/8 (total)(curb)

(b) Left hand wheel spindle has provisions for Speedo. take-off.

AMA Specifications – Passenger Car

MAKE OF CAR CORVAIR MODEL YEAR 1965 DATE ISSUED 9-28-64 REVISED (*)

MODEL <u>101-105-10700</u>	SPORT SEDANS	COUPES	CONVERTIBLES
----------------------------	--------------	--------	--------------

BODY – MISCELLANEOUS INFORMATION

Drs. hinged (front, rear)	Front doors	Front
	Rear doors	Front
Type of finish (lacquer, enamel, other)		Acrylic lacquer
Hood counterbalanced (yes, no)		Front compartment - yes; rear compartment - no
Hood release control (internal, external)		External (key lock - front compartment)
Vehicle (Serial) No. Location		LH rear top of side rail, rearward of battery
Engine No. Location		Top rear surface, left half of crankcase
Theft protection - type		Shielded ignition lock terminals, key removable in "OFF" position
Vent window control method (crank, friction pivot)	Front	Friction pivot
	Rear	None
Seat cushion type	Front	Formed wire and foam pad
	Rear	Formed wire and cotton-jute (a)
	3rd seat	None
Seat back type	Front	Formed wire and cotton-rubber
	Rear	Formed wire and cotton-foam pad
	3rd seat	None
Windshield glass type (i.e., single curved - laminated plate)		Single, curved laminated
Backlight glass type (i.e., compound curved - tempered plate, three piece)		One piece, curved Flat plastic
Side glass type (i.e., curved - tempered plate)		Curved
Side glass exposed surface area	1383.4	1416.6 1116.9
Windshield glass exposed surface area		1009.1
Backlight glass exposed surface area	814.4	1224.7 865.0
Total glass exposed surface area	3207.8	3550.4 2991.0

BODY – CONVENIENCE EQUIPMENT (Indicate whether standard, optional or NA on each series)

Power windows	Side Windows	NA
	Vent Windows	NA
	Backlight or tailgate	NA
Power seats (specify type as well as availability)		NA
Reclining front seat back		NA
Front seat headrest		NA
Radios (specify type as well as availability)		Manual, push button, AM-FM optional
Rear seat speaker		Optional for sedans and coupes
Power Antenna		NA
Clock		Optional
Air Conditioner (specify type and availability)		Recirculating, optional

(a) Foam pad on 10539

AMA Specifications – Passenger Car

MAKE OF CAR CORVAIR MODEL YEAR 1965 DATE ISSUED 9-28-64 REVISED (*)

WEIGHTS

	CURB WEIGHT - POUNDS			% PASS. WEIGHT DISTRIBUTION				SHIPPING * WEIGHT
	Front	Rear	Total	Pass. In Front		Pass. In Rear		
				Front	Rear	Front	Rear	
Model <u>101-105-10700</u>								
<u>500</u>								
<u>10137 2-Door Sport Cpe</u>			<u>2470</u>	<u>42</u>	<u>58</u>			<u>2385</u>
<u>10139 4-Door Sport Sed</u>			<u>2495</u>	<u>37</u>	<u>63</u>			<u>2405</u>
<u>Monza</u>								
<u>10537 2-Door Sport Cpe</u>			<u>2530</u>	<u>42</u>	<u>58</u>			<u>2440</u>
<u>10539 4-Door Sport Sed</u>			<u>2550</u>	<u>37</u>	<u>63</u>			<u>2465</u>
<u>10567 2-Door Convertible</u>			<u>2760</u>	<u>41</u>	<u>59</u>			<u>2675</u>
<u>Corsa</u>								
<u>10737 2-Door Sport Cpe</u>			<u>2560</u>	<u>41</u>	<u>59</u>			<u>2475</u>
<u>10767 2-Door Convertible</u>			<u>2805</u>	<u>41</u>	<u>59</u>			<u>2710</u>

Accessories & Equipment Differential Weights	Remarks
	<u>164</u>
<u>Air Conditioning</u>	<u>-105</u>
<u>Comfort & Conv.</u>	<u>+ 5</u>
<u>Engine Turbocharged</u>	<u>+ 13</u>
<u>Heater (delete)</u>	<u>- 48</u>
<u>Radio Manual</u>	<u>+ 7</u>
<u>Radio Push Button</u>	<u>+ 7</u>
<u>Radio AM-FM</u>	<u>+ 10</u>
<u>Seat Folding Rear</u>	<u>+ 30</u>
<u>Transmission Powerglide</u>	<u>+ 8</u>

* These are weights that are reported to states for licensing purposes.

AMA Specifications – Passenger Car

INDEX

SUBJECT	PAGE NO.	SUBJECT	PAGE NO.
Automatic Transmission	1, 16	Linings – Clutch, Brake	15, 19
Axis, Steering	21	Lubrication	6, 7, 15, 16, 17
Axle, Rear	1, 17	Luggage Capacity	1a
Battery	10	Motor, Starting	10
Bearings, Engine	4, 5, 6	Muffler	7
Belts – Fan, Generator, Water Pump	9	Overdrive	16
Body – General Information, types	Title, 1, 22	Piston Pins & Rings	2, 4
Exterior Dimensions	1	Pistons	2
Interior Dimensions	1a	Power Brakes	18
Brakes – Parking, Service, Power	18, 19	Power Steering	20
Camber	21	Power Teams	3
Camshaft	5	Propeller Shaft, Universal Joints	16, 17
Capacities		Pumps – Oil, Fuel	7, 8
Cooling System	9	Water	9
Fuel Tank	8	Radiator, Hoses	9
Lubricants		Ratios – Axle	1, 3, 17
Engine Crankcase	7	Compression	1, 2, 3
Transmission and Overdrive	15, 16	Steering	20
Rear Axle	17	Transmission	15, 16
Carburetor	3, 8	Rear Axle	1, 3, 17
Caster	21	Regulator – Generator	10
Choke, Automatic	8	Rims	18
Circuit Breakers, Fuses	14	Rings, Piston	4
Clutch – Pedal Operated	15	Rods – Connecting	4
Coil, Ignition	11	Shock Absorbers, Front & Rear	19
Connecting Rods	4	Spark Plugs	11
Cooling System	9	Speedometer	12
Crankcase Ventilation	7	Springs – Front & Rear Suspension	20, 21
Crankshaft	5	Valve, Engine	6
Cylinders and Cylinder Head	2	Stabilizer (Sway Bar) – Front & Rear	20, 21
Distributor – Ignition	11	Starting Motor	10
Electrical System	10, 11, 12, 13, 14	Steering	20, 21
Engine		Suppression – Ignition, Radio	11
Bore, Stroke, Displacement, Type	1, 2	Suspension – Front & Rear	19, 20, 21
Compression Ratio	1, 2	Switches	12
Firing Order, Cylinder Numbering	2, 11	Tailpipe	7
General Information, H.P. & Torque	1, 2	Thermostat, Cooling	9
Lubrication	6, 7	Timing, Engine & Valve	5, 6, 11
Power Teams	3	Tires	1, 18
Exhaust System	7	Toe in	21
Equipment Availability	22	Torque Converter	16
Fan, Cooling	9	Torque – Engine, Rated	1, 2, 3
Filters – Engine Oil, Fuel System	7, 8	Transmission – Types	1, 3, 8, 15, 16
Frame	19	Automatic	1, 3, 8, 15, 16
Front Suspension	19, 20	Manual & Overdrive	1, 3, 8, 15, 16
Fuel, Fuel Pump, Fuel System	1, 2, 8	Ratios	15, 16
Fuel Injection	1, 8	Tread	1
Fuses, Circuit Breakers	14	Trunk Luggage Capacity	1a
Generator and Regulator	10	Turning Diameter	20
Glass	22	Unitized Construction	19
Height (Lamps)	14	Universal Joints, Propeller Shaft	16, 17
Headroom – Body	1a	Valves – Intake & Exhaust	5, 6
Heights – Overall	1	Vibration Damper	5
Horns	12	Voltage Regulator	10
Horsepower – Brake	1, 2, 3	Water Pump	9
Ignition System	11	Weights – Shipping, Curb	23
Inflation – Tires	18	Wheel Alignment	21
Instruments	7, 12	Wheelbase	1
Kingpin (Steering Axis)	21	Wheels & Tires	18
Lamp Bulbs	13	Wheel Spindle	21
Lamp Height & Spacing	14	Widths – Car & Body	1
Legroom	1a	Windshield	22
Lengths – Overall	1	Windshield Wiper	12
Lifters, Valve	5		