

# 2020 Mirai



LIFESTYLE



# High tech with a higher purpose.

---

Witness the power of hydrogen. The innovative 2020 Toyota Mirai Fuel Cell Electric Vehicle (FCEV) is one daring statement crafted to help shape the next generation of mobility. Engineers worked tirelessly to push the boundaries of hydrogen technology. This investment in hydrogen is an investment in sustainable mobility for all.

Mirai shown in Salsa Red Pearl. Prototype shown.



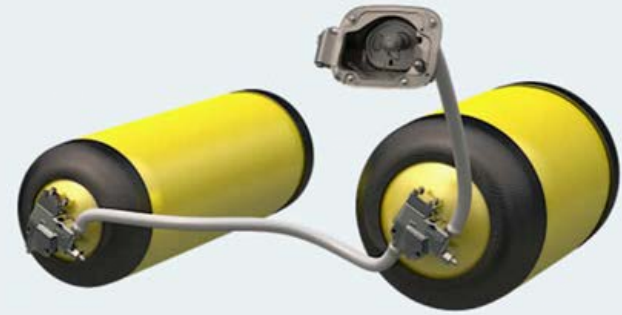
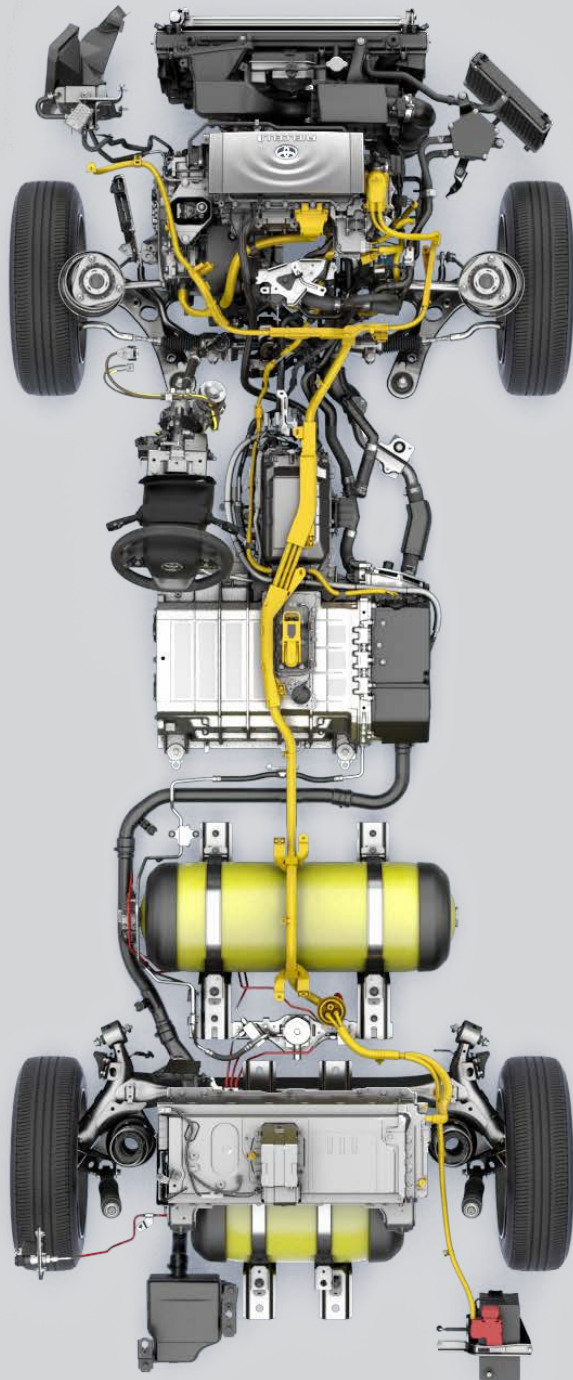

---

“We had to create our own carbon-fiber wrapping process, which increased the speed of wrapping over six times from our previous method — far faster than anything available in the rest of the industry at the time of development. It shouldn’t be too surprising that our automotive engineers could shift gears and develop this new method, given Toyota’s origination as a loom company.”

— Jackie Birdsall, Senior Engineer,  
Toyota Motor North America

---



# How it works

The Power Control Unit (PCU) decides when to use stored energy from the battery or to draw energy directly from the fuel cell system. This is part of what makes Mirai so energy efficient, and is based on the proven Toyota hybrid PCU found in Prius.



## THE MOTOR

We utilized our in-house, technological know-how to select the right electric motor for Mirai. This motor has been rigorously tested across all types of environments and conditions, and delivers the reliability you expect from Toyota.

## THE BOOST CONVERTER

Our four-phase boost converter brings voltage to 650 volts. Driving at a higher voltage makes more efficient use of the motor, giving Mirai a power output equivalent to other hybrids in Toyota's portfolio.





# The fuel cell system

The fuel cell system generates power by combining hydrogen with oxygen from the outside air. Toyota has helped lead the industry in this fuel cell system efficiency, achieving a high power output from a relatively compact system.

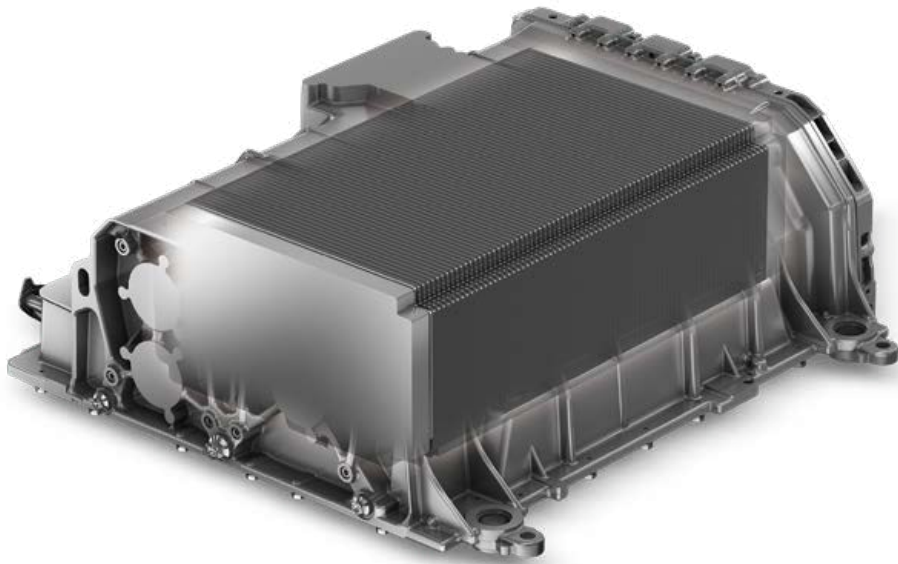

## THE BATTERY

The battery allows for regenerative braking and also assists during high-power demands like accelerating — improving total system efficiency and fuel economy. Like the motor, the battery is sourced from proven Toyota hybrid technology.

## THE HYDROGEN TANKS

All of our hydrogen tanks are produced in-house and specially designed for Mirai. Toyota's history in the loom-weaving business helped our engineers design the carbon-fiber weaving on our tanks, improving production efficiencies and helping to optimize the weight-to-storage ratio.



---

“As of today, Toyota solely owns approximately 5,680 hydrogen-fuel-cell-related global patents. Approximately 1,970 licenses are related to the fuel cell stack, about 290 to the high-pressure hydrogen tank and about 3,350 to fuel cell system control technology.”

— Bob Carter, EVP of Sales,  
Toyota Motor North America

---





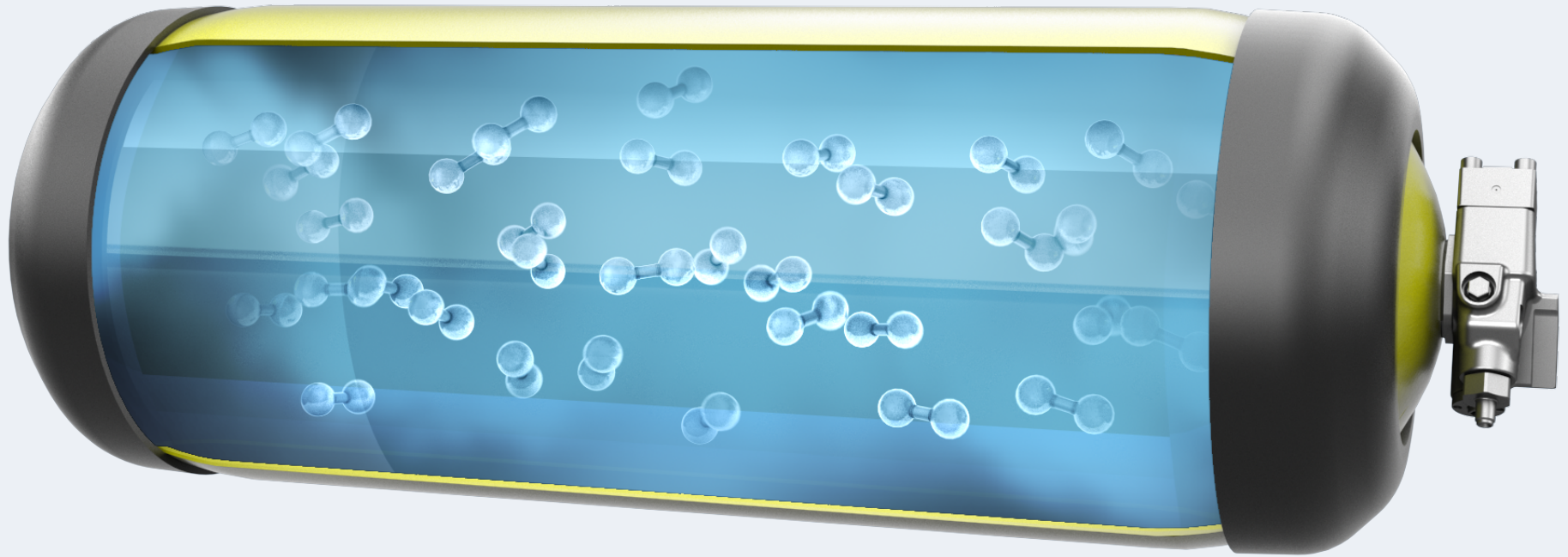

## Fuel a more sustainable tomorrow.

---

With our Environmental Challenge 2050, Toyota aims to create a society where people, cars and nature will coexist in harmony. One pillar of this challenge is to reduce vehicle CO<sub>2</sub> emissions by 90 percent compared to 2010 levels, and one of the key ways to achieve this goal will be through the utilization of hydrogen as a fuel source. Wider adoption of hydrogen-powered fuel cell electric vehicles could lead to reduced emissions of greenhouse gases, helping to create a better environment for all.

# Hydrogen is fuel. Pure and simple.

---

There are a lot of ways to produce hydrogen. But hydrogen binds to almost anything, so before it can be used, it must be separated. A variety of process technologies are available today, like steam reforming, electrolysis and gasification.



## STEAM REFORMING

Steam reforming of methane is the most common method for producing hydrogen today. It starts with liquids or gases containing hydrogen, like natural gas or sustainable biogas sourced from landfills. The fuel then reacts with steam at high temperatures in a reformer, leaving you with hydrogen.



## ELECTROLYSIS

Hydrogen can also be produced by separating water into its two primary elements — hydrogen ( $H_2$ ) and oxygen ( $O_2$ ). This process, known as electrolysis, passes an electrical current through the water to extract hydrogen. The electricity can be sourced from clean, renewable energy such as wind, solar or hydro.



## GASIFICATION

Gasification is a process in which organic materials, like crops and livestock waste, are converted into hydrogen. The organic materials are placed under high temperatures, which trigger a reaction that separates the hydrogen.



# You already know how to fill up.

Refueling a Mirai isn't complicated. There's a pump and a nozzle, just like at a gasoline station. After approximately five minutes,<sup>44</sup> you'll be ready to hit the road.

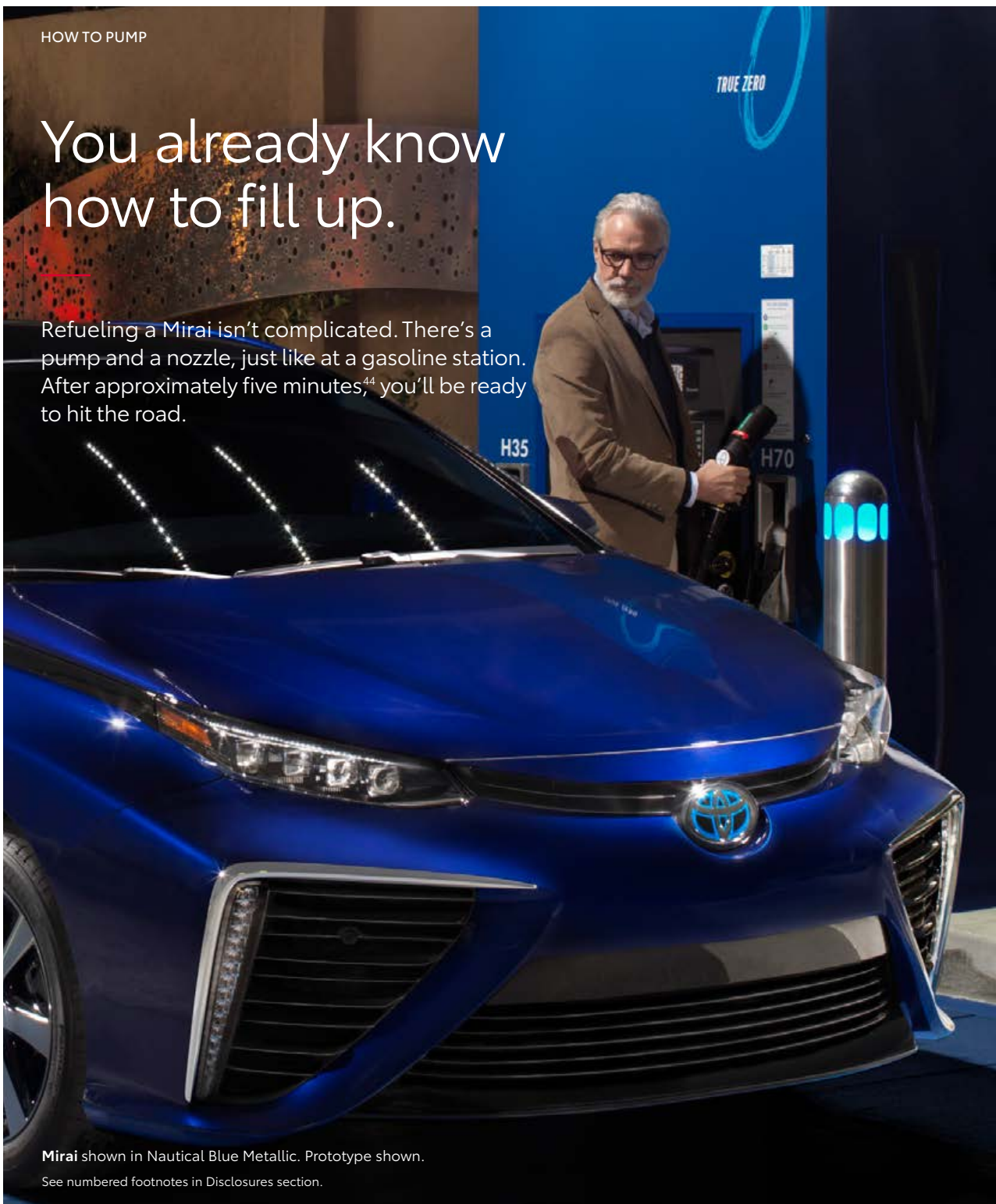

Mirai shown in Nautical Blue Metallic. Prototype shown.

See numbered footnotes in Disclosures section.

## STEP #1

Place the nozzle over the receptacle, creating a secure connection. Unlike gasoline pumps, hydrogen nozzles have a barrel that fits over the car receptacle.



## STEP #2

Squeeze the handgrip latch to lock the nozzle into place. The pump will not start until the nozzle is properly engaged, preventing any hydrogen from leaking.

## STEP #3

Let the computer top it off. During fueling, Mirai's hydrogen fuel control computer disables the vehicle and communicates with the station pump, allowing the vehicle to fill up safely and efficiently.



## STEP #4

Wait for the click to let you know fueling is complete. When complete, pull up the handgrip latch to unlock the nozzle and return it to the holder.

# Rethinking the fuel tank.

It all starts with hydrogen. When you pump hydrogen into the vehicle, it travels to carbon-fiber-reinforced fuel tanks where it's stored. A vehicle as groundbreaking and revolutionary as the hydrogen-fueled Toyota Mirai is coupled with equally groundbreaking and revolutionary technology.

1. **Inner:** polymer-lined layer to hold the hydrogen
2. **Middle:** structural layer of carbon-fiber-reinforced polymer to provide strength
3. **Outer:** fiber-glass reinforced polymer layer to help protect from surface abrasions





# Buying into clean energy doesn't mean buying into the unknown.

As with Prius, we proved that alternative-fuel vehicles can be mainstream as well as fashionable. Now we're doing the same with Mirai. Toyota engineers have spent decades developing Mirai's fuel cell powertrain to deliver the quality, reliability and dependability expected from Toyota. This means that Mirai operates just like a regular passenger car, while creating zero emissions. Since its hydrogen fuel can be created from renewable resources like solar, wind and biowaste, Mirai is helping to usher in a new era powered by clean energy.



## FIRST COMES AIR

The FCEV's front intake grilles deliver the outside air to the fuel cell system.



## WHICH MAKES ELECTRICITY

Hydrogen travels from the tanks to the fuel cell system. In the fuel cell system, hydrogen and oxygen from the air combine in a chemical reaction that creates electricity to power the vehicle.



## MOVING YOU FORWARD

When you put your foot on the accelerator, electricity from the fuel cell system is sent to the motor.



## LEAVING NOTHING BUT WATER

In the end, the only by-product of creating electricity with hydrogen and oxygen in our fuel cell system is water, which leaves through a hatch located on the bottom of Mirai.

# A global effort. Committed to safety.

Global Technical Regulation No.13 is an agreement between Japan, Europe and North America that sets the safety requirements that all high-pressure hydrogen systems must adhere to.<sup>47</sup> Compliance with this regulation is tough, and requires hydrogen tanks to be dropped, frozen, damaged, exposed to chemicals, hydraulically and pneumatically cycled, stuck on a bonfire and ultimately burst to ensure tank performance throughout the lifetime of the vehicle. Toyota engineers have worked to ensure that Mirai's hydrogen tanks meet these regulations so that drivers may enjoy years of emission-free driving.

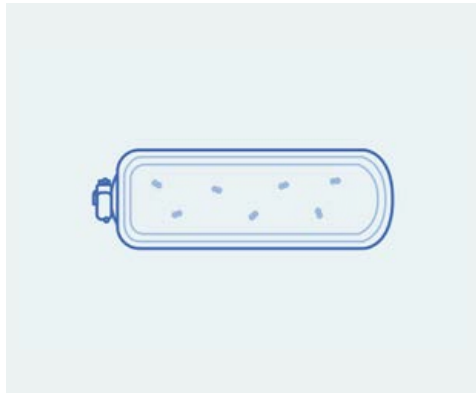

## OUR TANKS ARE DESIGNED NOT TO LEAK

Our multi-patented, carbon-fiber-wrapped, polymer-lined tanks are built in a three-layer structure and absorb five times the crash energy of steel.



## IN A HIGH-SPEED COLLISION, SENSORS STOP THE FLOW OF HYDROGEN

To prevent hydrogen from traveling to potentially damaged systems outside of the tank, the system is designed to automatically shut off the tank's hydrogen output valve.

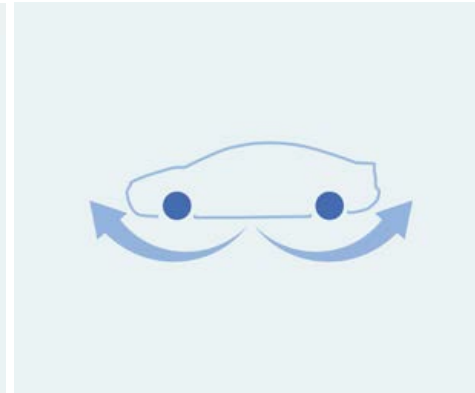

## ANY LEAKED HYDROGEN IS QUICKLY DISPERSED

All hydrogen-related parts are located outside the cabin and are designed to help prevent leaked hydrogen from building up.

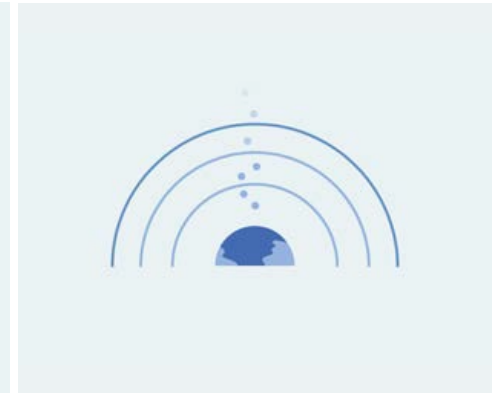

## HYDROGEN ESCAPES SAFELY INTO THE ATMOSPHERE

Since hydrogen is lighter than air, it rapidly disperses, reducing the time to cause damage in the event of an ignition.



**INTELLIGENT CLEARANCE SONAR<sup>42</sup> WITH REAR CROSS-TRAFFIC BRAKING<sup>56</sup>**

Available Intelligent Clearance Sonar (ICS) warns you both audibly and visually when it detects nearby pedestrians or vehicles. Under certain low-speed conditions, Rear Cross-Traffic Braking (RCTB) is designed to reduce engine power and apply the brakes if necessary.

Mirai shown in Salsa Red Pearl and Nautical Blue Metallic. Prototypes shown.

See numbered footnotes in Disclosures section.



# Proven peace of mind.

Over the years, Mirai prototypes have been meticulously evaluated — including rigorous in-house crash testing and more than 10,000 miles of extreme climate testing — helping to ensure the same world-class safety you'll find in any Toyota vehicle. The cabin is equipped with a driver and front passenger Advanced Airbag System,<sup>36</sup> front seat-mounted side airbags for the driver and front passenger, front and rear side curtain airbags, plus driver knee and front passenger seat-cushion airbags. They're all part of a system designed to help keep you safe.



## BODY STRUCTURE AND DESIGN

Mirai features a unique frame designed to distribute crash forces efficiently. In the event of a collision, the impact force is distributed around the passenger cabin and the Toyota fuel cell system and hydrogen tanks, reducing body deformation and helping to reduce the chance of injury. The collapsible steering column also helps protect the driver by absorbing force during impact.



## SAFETY CONNECT<sup>®14</sup>

With available Safety Connect,<sup>®</sup> emergency assistance is within your reach. Safety Connect<sup>®</sup> offers subscribers helpful features such as Emergency Assistance, Stolen Vehicle Locator,<sup>39</sup> Roadside Assistance<sup>40</sup> and Automatic Collision Notification. Three-year trial included.<sup>15</sup>



## ADVANCED SAFETY SYSTEM

Mirai is equipped with Toyota's Star Safety System,<sup>™</sup> a suite of safety features for braking, stability and traction control. These include Enhanced Vehicle Stability Control (VSC),<sup>33</sup> Traction Control (TRAC), 4-wheel Anti-lock Brake System (ABS), Electronic Brake-force Distribution (EBD), Brake Assist (BA)<sup>34</sup> and Smart Stop Technology<sup>®</sup> (SST).<sup>35</sup>



# Designed for safety.

Toyota Safety Sense™ 2.0 (TSS 2.0)<sup>27</sup> is a bundle of active safety features standard on every 2020 Mirai. These innovative features were designed to help protect you and your passengers from harm.



## PRE-COLLISION SYSTEM WITH PEDESTRIAN DETECTION<sup>28</sup>

Pre-Collision System with Pedestrian Detection (PCS w/PD) is designed to help keep the road safe by detecting a vehicle, pedestrian or bicyclist in certain situations. The latest system has enhanced low-light capabilities for pedestrian detection. By combining millimeter-wave radar with a camera capable of certain shape recognition, the system provides an audio/visual alert, warning you of a possible collision under certain circumstances. If you don't react, the system is designed for automatic braking support to help mitigate the potential for a collision.

See numbered footnotes in Disclosures section.

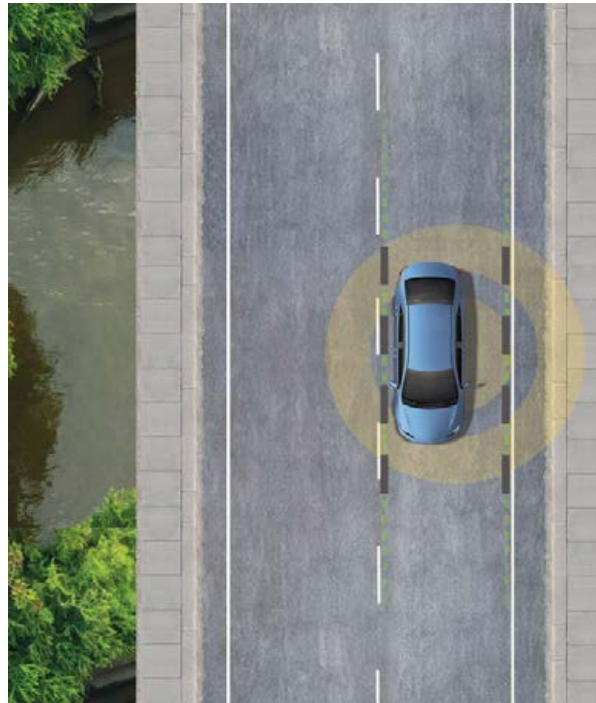

## LANE DEPARTURE ALERT WITH STEERING ASSIST<sup>21</sup> AND ROAD EDGE DETECTION

Using Road Edge Detection or by detecting visible lane markings, Lane Departure Alert with Steering Assist (LDA w/SA) is designed to issue both an audible alert and visual warning on the MID screen if an inadvertent lane departure is detected at speeds above 32 mph. If the system determines that the driver is not taking corrective steering action, the Steering Assist function is designed to initiate and provide gentle corrective steering to help keep the vehicle in the lane.

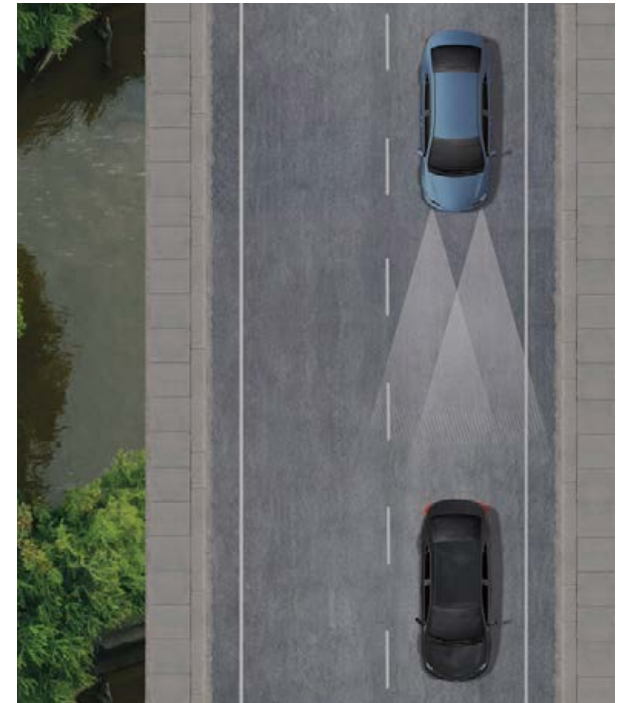

## AUTOMATIC HIGH BEAMS<sup>30</sup>

The Automatic High Beams (AHB) feature is a safety system designed to help you see more clearly at night — without distracting other drivers. Designed to activate at speeds above 25 mph, AHB relies on an in-vehicle camera to help detect the headlights of oncoming vehicles and taillights of preceding vehicles, then automatically toggles between high and low beams accordingly to provide the appropriate amount of light. By using high beams more frequently, the system may allow for earlier detection of pedestrians and obstacles.



**DYNAMIC RADAR CRUISE CONTROL<sup>31</sup>**

Intended for highway use and similar to “constant speed” cruise control, Dynamic Radar Cruise Control (DRCC) lets you drive at a preset speed. DRCC is designed to function at speeds of 25-110 mph and uses vehicle-to-vehicle distance control, which is designed to adjust your speed, to help you maintain a preset distance from the vehicle ahead of you that is driving at a slower speed. DRCC uses a front-grille-mounted radar and an in-vehicle camera designed to detect vehicles and their distance. If a driver is traveling slower than you, or within your preset range, DRCC is designed to automatically slow your vehicle down without deactivating cruise control. If DRCC determines you need to slow down more, an audio and visual alert notifies you and brakes are applied. When there’s no longer a vehicle driving slower than your set speed in front of you, DRCC will then accelerate to the preset speed and regular cruise control will resume.

See numbered footnotes in Disclosures section.



**ROAD SIGN ASSIST<sup>32</sup>**

Road Sign Assist (RSA) is designed to help keep the road safe. Using a forward-facing intelligent camera, Road Sign Assist is designed to detect speed limit signs, stop signs, yield signs and Do Not Enter signs, and display them on the MID.





## One comprehensive benefits package.

The Mirai experience includes a number of exceptional services, including enhanced ToyotaCare<sup>50</sup> for 3 years or 35,000 miles, whichever comes first, and enhanced roadside assistance<sup>51</sup> for 3 years, unlimited mileage. Also included is a Complimentary Rental Experience, with use of a rental Toyota for up to 21 days within three years.<sup>52</sup> An 8-year/100,000-mile warranty of the fuel cell components<sup>53</sup> helps to ensure that this FCEV is ready to go the distance. And with 3 years or up to \$15,000 worth of complimentary fuel,<sup>54</sup> Mirai makes it even easier to embrace sustainability.

Learn more at: [Toyota.com/Mirai/Pricing](https://Toyota.com/Mirai/Pricing)

Contact your nearest dealer at: [Toyota.com/Mirai/Contact](https://Toyota.com/Mirai/Contact)

Mirai shown in Nautical Blue Metallic and Salsa Red Pearl. Prototypes shown.

See numbered footnotes in Disclosures section.





### Exterior Features

- LED low- and high-beam headlights with Automatic High Beams (AHB)<sup>30</sup> with auto on/off feature
- LED Daytime Running Lights (DRL)
- LED stop lights
- Black sport front grille
- Exclusive fuel cell vehicle badging
- Color-keyed heated power auto-dimming outside mirrors with turn signal and blind spot warning indicators<sup>2</sup>; reverse tilt and power-folding features with 2-position memory function
- Color-keyed outside door handles (with touch-sensor lock/unlock feature on front doors)
- 17-in. silver-painted, machined, engraved alloy wheels with black-painted accents and P215/55R17 tires
- Rain-sensing, washer-linked, variable intermittent windshield wiper with heated windshield wiper de-icer
- Acoustic noise-reducing windshield and front/rear side glass

### Interior Features

- Dual zone automatic climate control with Intelligent Touch controls, cabin air filter and individually controlled rear-seat vents
- Intelligent Touch controls for heated seats, heated steering wheel and windshield wiper de-icer
- Premium Audio with JBL® w/Clari-Fi<sup>®3</sup> and Dynamic Navigation<sup>4</sup> — includes 11 speakers including subwoofer, amplifier, 7-in. touch-screen, CD player, auxiliary port, USB media port,<sup>5</sup> Dynamic Navigation<sup>4</sup> with up to a 3-year trial,<sup>6</sup> Dynamic POI Search, Dynamic Voice Recognition<sup>7</sup>, hands-free phone capability and music streaming<sup>8</sup> via Bluetooth<sup>®8</sup> wireless technology, Siri<sup>®</sup> Eyes Free<sup>9</sup>, HD Radio,<sup>7M10</sup> SiriusXM<sup>®11</sup> with 3-month All Access trial,<sup>12</sup> Connected Services<sup>13</sup> — Safety Connect<sup>®14</sup> with 3-year trial,<sup>15</sup> Wi-Fi Connect Powered by Verizon<sup>16</sup> with up to 2GB within 6-month trial<sup>17</sup> and Destination Assist<sup>18</sup> with 6-month trial.<sup>19</sup> See [toyota.com/audio-multimedia](http://toyota.com/audio-multimedia) for details.
- Integrated backup camera<sup>20</sup> display with projected path
- TFT Multi-Information Display (MID), trip performance score, fuel consumption history, average fuel economy, fuel economy history, fuel cell system power level, Lane Departure Alert (LDA),<sup>21</sup> clock settings, trip history
- Water release control

### Interior Features (cont.)

- SofTex<sup>®</sup>-trimmed<sup>22</sup> two-stage heated front seats with contrasting inserts and seatback pockets; 8-way power-adjustable driver's seat with 2-position memory function and power lumbar support; 8-way power adjustable front passenger seat with power lumbar support
- SofTex<sup>®</sup>-trimmed<sup>22</sup> two-stage heated rear seats
- Smart Key System<sup>23</sup> on front doors and trunk with Push Button Start and remote illuminated entry
- Power door locks with shift-linked automatic lock/unlock feature and anti-lockout feature
- Multi-function front seat center console with carbon-fiber-style accents, sliding cover and armrest, two front cup holders, Qi-compatible wireless smartphone charging,<sup>25</sup> USB 2.0 port<sup>5</sup> with iPod<sup>®26</sup> connectivity and control
- One 12V rear auxiliary power outlet and two USB 2.1A charging ports<sup>5</sup>
- Four cup holders and two front bottle holders

### Safety Features

- Toyota Safety Sense™ 2.0 (TSS 2.0)<sup>27</sup> — Pre-Collision System with Pedestrian Detection (PCS w/PD)<sup>28</sup> with bicyclist detection and improved low-light capabilities, Lane Departure Alert with Steering Assist (LDA w/SA)<sup>21</sup> and Road Edge Detection, Sway Warning System (SWS),<sup>29</sup> Automatic High Beams (AHB)<sup>30</sup> Dynamic Radar Cruise Control (DRCC),<sup>31</sup> Road Sign Assist (RSA)<sup>32</sup>
- Star Safety System™ — includes Vehicle Stability Control (VSC)<sup>33</sup> Traction Control (TRAC), Anti-lock Brake System (ABS), Electronic Brake-force Distribution (EBD), Brake Assist (BA)<sup>34</sup> and Smart Stop Technology<sup>®</sup> (SST)<sup>35</sup>
- Eight airbags<sup>36</sup> — includes driver and front passenger Advanced Airbag System, driver and front passenger seat-mounted side airbags, driver knee airbag, passenger seat-cushion airbag, and front and rear side curtain airbags
- LATCH (Lower Anchors and Tethers for CHildren) includes lower anchors and upper tether anchors on rear seats
- Child-protector rear door locks
- Energy-absorbing collapsible steering column
- Front and rear energy-absorbing crumple zones
- Tire Pressure Monitor System (TPMS)<sup>37</sup>
- Collision sensors: deactivate high-voltage battery and close H<sub>2</sub> tank valves
- Vehicle Proximity Notification System (VPNS)<sup>38</sup>
- Safety Connect<sup>®14</sup> — includes Emergency Assistance, Stolen Vehicle Locator,<sup>39</sup> Roadside Assistance<sup>40</sup> and Automatic Collision Notification; with three-year trial subscription<sup>15</sup>
- Blind Spot Monitor (BSM)<sup>2</sup> with Rear Cross-Traffic Alert (RCTA)<sup>41</sup>
- Intelligent Clearance Sonar (ICS)<sup>42</sup> with Rear Cross-Traffic Braking (RCTB)<sup>56</sup>
- LED Daytime Running Lights (DRL) with on/off feature
- Anti-theft system with engine immobilizer<sup>43</sup>

## Color

Celestial Black<sup>55</sup>

Nautical Blue Metallic



Atmospheric Blue Metallic



Salsa Red Pearl

Elemental Silver<sup>55</sup>Crystal White<sup>55</sup>

## Trim



Deep Ocean Blue



Warm White

## Wheel



17-in. engraved alloy wheel

FEATURES<sup>1</sup>

	Mirai
<b>EXTERIOR</b>	
LED low- and high-beam headlights with Automatic High Beams (AHB) <sup>2</sup> with auto on/off feature	S
LED Daytime Running Lights (DRL)	S
LED stop lights	S
Black sport front grille	S
Color-keyed front bumpers with black inserts with chrome accents and color-keyed rear bumpers	S
Exclusive fuel cell vehicle badging	S
Color-keyed heated power auto-dimming outside mirrors with turn signal and blind spot warning indicators <sup>2</sup> ; reverse tilt and power-folding features with 2-position memory function	S
Color-keyed outside door handles (with touch-sensor lock/unlock feature on front doors)	S
17-in. silver-painted, machined, engraved alloy wheels with black-painted accents and P215/55R17 tires	S
Rain-sensing, washer-linked, variable intermittent windshield wiper with heated windshield wiper de-icer	S
Acoustic noise-reducing windshield and front/rear side glass	S
Color-keyed roof-mounted shark-fin antenna	S
<b>INTERIOR</b>	
Dual zone automatic climate control with Intelligent Touch controls, cabin air filter and individually controlled rear-seat vents	S
Intelligent Touch controls for heated seats, heated steering wheel and windshield wiper de-icer	S
Premium Audio with JBL® w/Clari-Fi <sup>3</sup> and Dynamic Navigation <sup>4</sup> — includes 11 speakers including subwoofer, amplifier, 7-in. touch-screen, AM/FM CD player, auxiliary port, USB media port; <sup>5</sup> Dynamic Navigation <sup>4</sup> with up to a 3-year trial <sup>6</sup> ; Dynamic POI Search, Dynamic Voice Recognition, <sup>7</sup> hands-free phone capability and music streaming <sup>8</sup> via Bluetooth <sup>®8</sup> wireless technology, Siri <sup>®</sup> Eyes Free, <sup>9</sup> HD Radio; <sup>7M10</sup> SiriusXM <sup>®11</sup> with 3-month All Access trial; <sup>12</sup> Connected Services <sup>13</sup> — Safety Connect <sup>®14</sup> with 3-year trial; <sup>15</sup> Wi-Fi Connect Powered by Verizon <sup>16</sup> with up to 2GB within 6-month trial <sup>17</sup> and Destination Assist <sup>18</sup> with 6-month trial. <sup>19</sup> See <a href="http://toyota.com/audio-multimedia">toyota.com/audio-multimedia</a> for details.	S
Integrated backup camera <sup>20</sup> display with projected path	S
TFT Multi-Information Display (MID), trip performance score, fuel consumption history, average fuel economy, fuel economy history, fuel cell system power level, Lane Departure Alert (LDA) <sup>21</sup> ; clock settings, trip history	S
SofTex <sup>®</sup> -trimmed <sup>22</sup> power heated tilt/telescopic steering wheel with 2-position memory function with piano-black accents and controls for audio, Multi-Information Display (MID), Bluetooth <sup>®8</sup> hands-free phone, voice command, Lane Departure Alert (LDA) <sup>21</sup> and Dynamic Radar Cruise Control (DRCC) <sup>31</sup>	S
Water release control	S
Piano-black shift lever with matte-silver accents	S
TFT Display with speedometer, odometer, two tripmeters, current trip information, outside temp, fuel level indicator, MPG <sub>e</sub> , ECO Driving Indicator, fuel cell system power level and battery charge indicator (also see Multi-Information Display)	S
SofTex <sup>®</sup> -trimmed <sup>22</sup> two-stage heated front seats with contrasting inserts and seatback pockets; 8-way power-adjustable driver's seat with 2-position memory function and power lumbar support; 8-way power adjustable front passenger seat with power lumbar support	S
SofTex <sup>®</sup> -trimmed <sup>22</sup> two-stage heated rear seats	S
Rear seat with center console and armrest cup holders	S
Piano-black interior trim with carbon-fiber-style and matte-silver interior accents and chrome door handles	S
Smart Key System <sup>23</sup> on front doors and trunk with Push Button Start and remote illuminated entry	S
Power windows with auto up/down and jam protection in all positions and retained-power features	S
Rear window defogger with timer	S
Power door locks with shift-linked automatic lock/unlock feature and anti-lockout feature	S
Frameless auto-dimming day/night rearview mirror with HomeLink <sup>®24</sup> universal transceiver	S
Multi-function front-seat center console with carbon-fiber-style accents, sliding cover and armrest, two front cup holders, Qi-compatible wireless smartphone charging; <sup>25</sup> USB 2.0 port <sup>5</sup> with iPod <sup>®26</sup> connectivity and control	S
Covered rear-seat center console with tilt open and armrest, storage compartment and two cup holders	S
Passenger-side lockable glove compartment	S
One 12V rear auxiliary power outlet and two USB 2.1A charging ports <sup>5</sup>	S
Dual extendable sun visors with sliding extensions and illuminated vanity mirrors	S
Overhead console with maplights and dome light, sunglasses storage, Safety Connect <sup>®14</sup> button	S
Front and rear dome lights, front maplights (reading lights)	S
Four cup holders and two front bottle holders	S

See numbered footnotes in Disclosures section.



FEATURES<sup>1</sup> (continued)

<b>SAFETY/CONVENIENCE</b>	<b>Mirai</b>
Toyota Safety Sense™ 2.0 (TSS 2.0) <sup>27</sup> — Pre-Collision System with Pedestrian Detection (PCS w/PD) <sup>28</sup> with bicyclist detection and improved low-light capabilities, Lane Departure Alert with Steering Assist (LDA w/SA) <sup>21</sup> and Road Edge Detection, Sway Warning System (SWS) <sup>29</sup> Automatic High Beams (AHB) <sup>30</sup> Dynamic Radar Cruise Control (DRCC) <sup>31</sup> Road Sign Assist (RSA) <sup>32</sup>	<b>S</b>
Star Safety System™ — includes Vehicle Stability Control (VSC) <sup>33</sup> Traction Control (TRAC), Anti-lock Brake System (ABS), Electronic Brake-force Distribution (EBD), Brake Assist (BA) <sup>34</sup> and Smart Stop Technology® (SST) <sup>35</sup>	<b>S</b>
Eight airbags <sup>36</sup> — includes driver and front passenger Advanced Airbag System, driver and front passenger seat-mounted side airbags, driver knee airbag, passenger seat-cushion airbag, and front and rear side curtain airbags	<b>S</b>
3-point seatbelts for all seating positions, driver-side Emergency Locking Retractor (ELR) and Automatic/Emergency Locking Retractor (ALR/ELR) on all passenger belts	<b>S</b>
Seatbelt pretensioners with force limiters for all seating positions	<b>S</b>
LATCH (Lower Anchors and Tethers for CHildren) includes lower anchors and upper tether anchors on rear seats	<b>S</b>
Child-protector rear door locks	<b>S</b>
Energy-absorbing collapsible steering column	<b>S</b>
Front and rear energy-absorbing crumple zones	<b>S</b>
Side-impact door beams	<b>S</b>
Tire Pressure Monitor System (TPMS) <sup>37</sup>	<b>S</b>
Collision sensors: deactivate high-voltage battery and close H <sub>2</sub> tank valves	<b>S</b>
Vehicle Proximity Notification System (VPNS) <sup>38</sup>	<b>S</b>
Safety Connect® <sup>14</sup> — includes Emergency Assistance, Stolen Vehicle Locator, <sup>39</sup> Roadside Assistance <sup>40</sup> and Automatic Collision Notification; with three-year trial subscription <sup>15</sup>	<b>S</b>
Blind Spot Monitor (BSM) <sup>2</sup> with Rear Cross-Traffic Alert (RCTA) <sup>41</sup>	<b>S</b>
Intelligent Clearance Sonar (ICS) <sup>42</sup> with Rear Cross-Traffic Braking (RCTB) <sup>56</sup>	<b>S</b>
LED Daytime Running Lights (DRL) with on/off feature	<b>S</b>
Anti-theft system with engine immobilizer <sup>43</sup>	<b>S</b>

SPECIFICATIONS for Toyota Fuel Cell System

<b>MECHANICAL/PERFORMANCE</b>	<b>Mirai</b>	<b>MECHANICAL/PERFORMANCE (continued)</b>	<b>Mirai</b>
<b>NAME</b>		<b>CELL</b>	
Toyota fuel cell system	<b>S</b>	Number of cells: 370	<b>S</b>
<b>TYPE</b>		Cell thickness: 1.34mm	<b>S</b>
Solid polymer electrolyte	<b>S</b>	Cell weight: 102g	<b>S</b>
<b>HUMIDIFICATION METHOD</b>		<b>SEPARATOR MATERIAL</b>	
Internal circulation form (humidifier-less)	<b>S</b>	Titanium	<b>S</b>
<b>MAX POWER OUTPUT</b>		<b>EMISSION RATING</b>	
153 hp	<b>S</b>	California Air Resources Board (CARB) Emission Standard: Zero Emissions Vehicle (ZEV)	<b>S</b>
<b>POWER DENSITY BY VOLUME</b>		Federal Environmental Protection Agency (EPA) Emission Standard: Tier 3 Bin 0	<b>S</b>
3.1 kW/L	<b>S</b>		
<b>POWER DENSITY BY WEIGHT</b>			
2.0 kW/kg	<b>S</b>		
<b>VOLUME</b>			
37 liters	<b>S</b>		
<b>WEIGHT</b>			
56 kg	<b>S</b>		

See numbered footnotes in Disclosures section.

**S** = Standard

SPECIFICATIONS for Toyota Fuel Cell System (continued)

	Mirai
<b>HYDROGEN TANK</b>	
<b>STORAGE METHOD</b>	
High-pressure tanks (two)	S
<b>TYPE</b>	
Type-4	S
<b>MAXIMUM FILLING PRESSURE</b>	
87.5 MPa	S
<b>NORMAL OPERATIONAL PRESSURE</b>	
70 MPa	S
<b>STORAGE CAPACITY</b>	
5.7 wt%	S
<b>SIZE (VOLUME)</b>	
122.4L (fore tank: 60 liters, aft tank: 62.4 liters)	S
<b>MATERIAL</b>	
Inner layer: polymer liner	S
Middle layer: carbon-fiber-reinforced polymer	S
Surface layer: fiber-glass-reinforced polymer	S
<b>REFUELING TIME<sup>44</sup></b>	
Approximately 5 minutes	S
<b>ELECTRIC MOTOR</b>	
<b>MOTOR TYPE</b>	
Permanent Magnet AC synchronous	S
<b>MAXIMUM OUTPUT</b>	
151 hp	S
<b>TORQUE</b>	
247 lb.-ft.	S
<b>DIMENSIONS</b>	
<b>EXTERIOR DIMENSIONS (in.)</b>	
Overall height	60.5
Overall width	71.5
Overall length	192.5
Wheelbase	109.5
Track (front/rear)	60.5/61
Minimum running ground clearance	5.1
Coefficient of drag (Cd)	.29
<b>INTERIOR DIMENSIONS, FRONT/REAR (in.)</b>	
Head room	38.5/36.8
Shoulder room	54.3/53.52
Hip room	53.4/52.4
Leg room	42.5/30.1
<b>BRAKES</b>	
Power-assisted ventilated front disc brakes; solid rear disc with integrated regenerative braking and Star Safety System™	S

	Mirai
<b>WEIGHTS AND CAPACITIES</b>	
Curb weight (lb.)	4075
Seating capacity	4
Passenger volume (cu. ft.)	85.7
Cargo volume <sup>45</sup> (cu. ft.)	12.8
<b>TIRES</b>	
<b>SIZE</b>	
P255/55R17	S
<b>DRIVE BATTERY</b>	
<b>TYPE</b>	
Sealed Nickel-Metal Hydride (Ni-MH), 34 cell modules	S
<b>POWER OUTPUT</b>	
244.8 V (7.2 V x 34 cell modules)	S
<b>POWER ON-DEMAND SYSTEM</b>	
<b>MAX ELECTRICITY OUTPUT</b>	
9 kW	S
<b>CRUISING RANGE</b>	
Approximately 300 miles <sup>46</sup>	S
<b>0-60</b>	
9.0 seconds	S
<b>MPGE<sup>46</sup>/OTHER</b>	
MPGe	67
Range (miles) <sup>46</sup>	312
<b>DRIVETRAIN</b>	
Front-Wheel Drive	S
<b>SUSPENSION</b>	
<b>FRONT</b>	
MacPherson strut	S
<b>REAR</b>	
Torsion beam	S
<b>STEERING</b>	
Electric Power Steering (EPS); power-assisted rack-and-pinion	S
Turning circle diameter, curb to curb (ft.)	37.4

## CARS BUILT FOR THE WAY YOU LIVE

At Toyota, we build cars for how you live. From building advanced safety features designed to help prevent crashes to driving cross-country to understand how we can make your driving experience better, our work starts with understanding your needs. Building cars for how you live also means thinking about tomorrow — from fuel efficiency and environmental innovations, to things beyond cars, like a bicycle that you can control with your mind. And because what we learn building cars can help improve lives in other places, we do things like help communities rebuild their homes quickly after a disaster and work with soup kitchens to help them serve more people faster. Toyota. Built for how you live. Together we are going places.

## DISCLOSURES

**1.** Toyota strives to build vehicles to match customer interest and thus they typically are built with popular options and option packages. Not all options/packages are available separately and some may not be available in all regions of the country. If you would prefer a vehicle with no or different options, contact your dealer to check for current availability or the possibility of placing a special order. Color(s) depicted may vary based on multiple factors, including ambient lighting and the format in which it is being viewed (e.g., computer, mobile device or print). **2.** Do not rely exclusively on the Blind Spot Monitor. Always look over your shoulder and use your turn signal. There are limitations to the function, detection and range of the monitor. See *Owner's Manual* for additional limitations and details. **3.** JBL® and Clari-Fi® are registered trademarks of Harman International Industries, Inc. **4.** Dynamic Navigation depends on an operative telematics device, a cellular connection, navigation map data and GPS signal strength, and other factors outside of Toyota's control, which can limit system functionality or availability. Services not available in every city or roadway. Use common sense when relying on information provided. Service may vary by vehicle and region. Registration is required. Terms and conditions of subscription services agreement apply. See *Owner's Manual* and <https://toyota.com/connected-services> for additional limitations and details. To learn about Toyota's data collection, use, sharing and retention, please visit <https://www.toyota.com/privacyvts/>. **5.** May not be compatible with all mobile phones, MP3/WMA players and like models. **6.** The Dynamic Navigation three-year trial begins the earlier of when the vehicle hits 100 miles or a year after the multimedia system manufacture date, regardless of when you purchase or lease the vehicle. Terms and conditions of subscription service agreement apply. **7.** Dynamic voice recognition capabilities vary by head unit. **8.** The Bluetooth® word mark and logos are registered trademarks owned by Bluetooth SIG, Inc., and any use of such marks by Toyota is under license. A compatible Bluetooth®-enabled phone must first be paired. Phone performance depends on software, coverage and carrier. **9.** Always focus on the road while driving. Siri® is available on select iPhone®/iPad® models and requires Internet access. Siri® is not available in all languages or all areas and features vary by area. Some Siri® functionality and commands are not accessible in the vehicle. See [apple.com](http://apple.com) and phone carrier for details. Data charges may apply. Siri® is a registered trademark of Apple Inc. **10.** HD Radio™ Technology manufactured under license from iBiquity Digital Corporation U.S. and Foreign Patents. HD Radio™ and the HD, HD Radio, and "Arc" logos are proprietary trademarks of iBiquity Digital Corp. **11.** SiriusXM® audio services require a subscription sold separately by Sirius XM Radio Inc. If you decide to continue service after your trial, the subscription plan you choose will automatically renew thereafter and you will be charged according to your chosen payment method at then-current rates. Fees and taxes apply. To cancel, you must call SiriusXM at 1-866-635-2349. See SiriusXM Customer Agreement for complete terms at [www.siriusxm.com](http://www.siriusxm.com). All fees and programming subject to change. Not all vehicles or devices are capable of receiving all services offered by SiriusXM. Current information and features may not be available in all locations, or on all receivers. ©2019 Sirius XM Radio Inc. SiriusXM and all related marks and logos are trademarks of Sirius XM Radio Inc. **12.** SiriusXM All Access trial length and service availability may vary by model, model year or trim. **13.** Connected Services depends on an operative telematics device, a cellular connection, navigation map data, GPS signal strength and other factors outside of Toyota's control, all of which can limit system functionality or availability, including access to response center and emergency support. Service may vary by vehicle and region. Apps and services subject to change at any time without notice. See [toyota.com/connected-services](https://toyota.com/connected-services) for details. To learn about Toyota's data collection, use, sharing and retention, please visit <https://www.toyota.com/privacyvts/>. Stolen vehicle police report required to use Stolen Vehicle Locator. **14.** Toyota Safety Connect® depends on an operative telematics device, a cellular connection, navigation map data and GPS signal strength and other factors outside of Toyota's control, all of which can limit system functionality or availability, including access to response center and emergency support. Stolen vehicle police report required to use Stolen Vehicle Locator. Registration required. Service subject to change at any time without notice. Terms and conditions of subscription service agreement apply. Service may vary by vehicle and region. See usage precautions and service limitations in *Owner's Manual* and at [toyota.com/connected-services/](https://toyota.com/connected-services/) for additional details. To learn about Toyota's data collection, use, sharing and retention, please visit <https://www.toyota.com/privacyvts/>. **15.** The Safety Connect® trial period is at no extra cost and begins on the original date of purchase or lease of a new vehicle. After the trial period expires, enrollment in paid subscription is required to access the service. **16.** Wi-Fi Connect is available on select 2018 and newer Toyota vehicles. Visit [toyota.com](https://toyota.com) for vehicle availability. Verizon Wireless is the network provider for Wi-Fi Connect, which uses Verizon's 4G LTE network to transmit data. Data usage and charges apply. Coverage not available everywhere; see [vzw.com](http://vzw.com). See [verizonwireless.com/bestnetwork](http://verizonwireless.com/bestnetwork) for details. LTE is a trademark of ETSI. Other terms apply. Up to 5 devices can be supported using in-vehicle connectivity. Verizon Wireless data subscription required upon end of 6-month trial period or use of 2-GB data (whichever comes first). Use of Wi-Fi Connect subject to Verizon Wireless' Customer Agreement ([verizonwireless.com/legal/notices/customer-agreement/](http://verizonwireless.com/legal/notices/customer-agreement/)), Privacy Policy ([verizon.com/about/privacy/privacy-policy-summary](http://verizon.com/about/privacy/privacy-policy-summary)), and data use policies ([verizonwireless.com/support/vz-email-legal/](http://verizonwireless.com/support/vz-email-legal/)). Apps and services subject to change at any time without notice. **17.** The Wi-Fi Connect trial period is at no extra cost and begins on the date of activation. After the trial period expires, enrollment in a paid subscription is required to access the service. Terms and conditions apply. **18.** Destination Assist depends on an operative telematics device, a cellular connection, navigation map data and GPS signal strength and other factors outside of Toyota's control, which can limit system ability functionality or availability. Use common sense when relying on this information. Service may vary by vehicle and region. Registration required. Services subject to change at any time without notice. Terms and conditions of subscription services agreement apply. See *Owner's Manual* and [toyota.com/connected-services](https://toyota.com/connected-services) for additional limitations and details. To learn about Toyota's data collection, use, sharing and retention, please visit <https://www.toyota.com/privacyvts/>. **19.** The Destination Assist Connect trial period is at no extra cost and begins on the original date of purchase or lease of a new vehicle. After the trial period expires, enrollment in a paid subscription is required to access the service. **20.** The backup camera does not provide a comprehensive view of the rear area of the vehicle and you should also look around the vehicle, using mirrors to confirm rearward clearance. Environmental conditions may limit effectiveness and view may become obscured. See *Owner's Manual* for additional limitations and details. **21.** Lane Departure Alert with Steering Assist is designed to read visible lane markers under certain conditions. It provides a visual and audible alert and slight steering force when lane departure is detected. It is not a collision-avoidance system or a substitute for safe and attentive driving. Effectiveness is dependent on many factors including road, weather and vehicle conditions. See *Owner's Manual* for additional limitations and details. **22.** SofTex® is a registered trademark of Toyota Motor Sales, U.S.A., Inc. **23.** The Smart Key System may interfere with some pacemakers or cardiac defibrillators. If you have one of these medical devices, please talk to your doctor to see if you should deactivate this system. **24.** HomeLink® and the HomeLink® house icon are registered trademarks of Gentex Corporation. **25.** Qi wireless charging may not be compatible with all mobile phones, MP3/WMA players and like models. When using the wireless charging system, avoid placing metal objects between the wireless charger and the mobile device when charging is active. Doing so may cause metal objects to become hot and could cause burns. **26.** iPod® and iPhone® are registered trademarks of Apple Inc. All rights reserved. **27.** Toyota Safety Sense™ effectiveness is dependent on many factors including road, weather and vehicle conditions. Drivers are responsible for their own safe driving. Always pay attention to your surroundings and drive safely. See *Owner's Manual* for additional limitations and details. **28.** The Pre-Collision System (PCS) with Pedestrian Detection (PD) is designed to determine if impact is imminent and help reduce impact speed and damage in certain frontal collisions involving a vehicle, a pedestrian or a bicyclist. PCS w/PD is not a substitute for safe and attentive driving. System effectiveness depends on many factors, such as speed, size and position of pedestrian and weather, light and road conditions. See *Owner's Manual* for additional limitations and details. **29.** Sway Warning is designed to provide a visual and audible alert if it detects a pattern of vehicle movement that might indicate driver inattention or drowsiness. It is not a collision-avoidance system or a substitute for safe and attentive driving. Effectiveness is dependent on many factors including road, weather and vehicle conditions. See *Owner's Manual* for additional limitations and details. **30.** Automatic High Beams operate at speeds above 25 mph. Factors such as a dirty windshield, weather, lighting and terrain limit effectiveness, requiring the driver to manually operate the high beams. See *Owner's Manual* for additional limitations and details. **31.** Dynamic Radar Cruise Control is designed to assist the driver and is not a substitute for safe and attentive driving practices. System effectiveness is dependent on many factors including road, weather and traffic conditions. See *Owner's Manual* for additional limitations and details. **32.** Do not rely exclusively on Road Sign Assist (RSA). RSA is a driver support system that utilizes the vehicle's forward-facing camera and navigation system to recognize certain road signs and provide information to the driver via the multi-information display and/or Head-Up Display. Effectiveness is dependent on road, weather, vehicle and sign conditions. Use common sense when using RSA and do not drive distracted. See *Owner's Manual* for additional limitations and details. **33.** Vehicle Stability Control is an electronic system designed to help the driver maintain vehicle control under adverse conditions. It is not a substitute for safe and attentive driving practices. Factors including speed, road conditions, weather and driver steering input can all affect whether VSC will be effective in preventing a loss of control. See *Owner's Manual* for additional limitations and details. **34.** Brake Assist is designed to help the driver take advantage of ABS and is not a substitute for safe driving practices. Braking effectiveness also depends on proper vehicle maintenance, tire and road conditions. See *Owner's Manual* for additional limitations and details. **35.** Smart Stop Technology® operates only in the event of certain contemporaneous brake and accelerator pedal applications. When engaged, the system will reduce power to help the brakes bring the vehicle to a stop. Factors including speed, road conditions and driver input can all impact



## DISCLOSURES (continued)

stopping distance. Smart Stop Technology® is not a substitute for safe and attentive driving and does not guarantee instant stopping. See *Owner's Manual* for additional limitations and details. **36.** Airbag systems are Supplemental Restraint Systems and are designed to inflate only under certain conditions and in certain types of severe collisions. To decrease the risk of injury from an inflating airbag, always wear seatbelts and sit upright in the middle of the seat as far back as possible. Do not put objects in front of an airbag or around the seatback. Do not use a rearward-facing child seat in any front passenger seat. See *Owner's Manual* for additional limitations and details. **37.** The Tire Pressure Monitor System alerts the driver when tire pressure is critically low. For optimal tire wear and performance, tire pressure should be checked regularly with a gauge; do not rely solely on the monitor system. See *Owner's Manual* for additional limitations and details. **38.** This device is not a substitute for safe and attentive driving practices. It is the driver's responsibility to maintain a lookout for pedestrians, cyclists, other cars and objects, and to drive the vehicle in a safe and attentive manner to avoid making contact. **39.** Building and/or parking structures may limit system effectiveness. Stolen vehicle police report required to use Stolen Vehicle Locator. For additional assistance contact the Toyota Customer Experience Center at 1-800-331-4331. **40.** Requires adequate cellular coverage and GPS signal strength. May not work in all areas. Service may vary by vehicle and region. See Toyota Dealer for details and exclusions. **41.** Do not rely exclusively on the Rear Cross-Traffic Alert system. Always look over your shoulder and use your mirrors to confirm rear clearance. There are limitations to the function, detection and range of the system. See *Owner's Manual* for additional limitations and details. **42.** Intelligent Clearance Sonar (ICS) is designed to assist drivers in avoiding potential collisions at speeds of 9 mph or less. Certain vehicle and environmental factors, including an object's shape and composition, may affect the ability of the ICS to detect it. Always look around outside the vehicle and use mirrors to confirm clearance. See *Owner's Manual* for additional limitations and details. **43.** The engine immobilizer is a state-of-the-art anti-theft system that is initiated when you insert your key into the ignition switch or bring a Smart Key fob into the vehicle. The engine will only start if the code in the transponder chip inside the key/fob matches the code in the vehicle's immobilizer. The transponder chip is embedded in the key/fob and can be costly to replace. If you lose a key or fob, your Toyota dealer can help or go to [www.aloa.org](http://www.aloa.org) to find a qualified locksmith in your area who can perform high-security key service. **44.** Fueling time varies with hydrogen fueling pressure and ambient temperature. **45.** Cargo and load capacity limited by weight and distribution. Always properly secure cargo and cargo area. **46.** 2020 EPA-estimated 67 city/67 highway/67 combined MPGe for Mirai and 312-mile driving range. Actual mileage will vary for many reasons including driving conditions and how you drive and maintain your vehicle. Range measurement pursuant to SAE J2601 standards (ambient temperature: 20°C; hydrogen tank pressure when fueled: 70 MPa). Fueling time varies with hydrogen fueling pressure and ambient temperature. **47.** The Mirai meets all applicable Federal Motor Vehicle Safety Standards requirements, almost all of which apply equally to similar gasoline powered vehicles. In addition, Toyota has engineered the Mirai and its hydrogen tanks to meet international Global Technical Regulations. **48.** TMS U.S.A. is not responsible for operability of stations, whether any station has available fuel at any time, or their progress in construction. Projected operational dates are estimates and subject to change as a result of permit application/approval process, construction process and station certification process. Because hydrogen is a new fuel source, shortages can occur. There is a current hydrogen fuel shortage in California. **49.** Projected hydrogen station operational dates are TMS U.S.A.'s best estimates for when stations will be available for use by Mirai customers according to representation of construction progress by California Governor's Office of Business and Economic Development (Go-Biz). Operational date estimates are based on construction start date. **50.** Standard ToyotaCare covers normal factory scheduled maintenance for two years or 25,000 miles, whichever comes first and also includes 24-hour roadside assistance for two years, regardless of mileage. The Mirai enhancement of ToyotaCare—a total of 3 years or 35,000 miles, whichever comes first—is valid only at authorized Mirai Fuel Cell dealers in the continental United States. See an Authorized Mirai Fuel Cell dealer for details and exclusions. **51.** Roadside Assistance coverage is 3 years unlimited mileage. Does not include parts and fluids, except emergency fuel delivery. See Toyota Dealer for details and exclusions. Valid only in the continental U.S. and Alaska. **52.** The twenty-one complimentary days will expire after the third year and any unused days will not carry over. **53.** Valid only at Authorized Mirai Fuel Cell Dealers in the continental United States. See dealer for details and exclusions. **54.** Complimentary fuel for three years or \$15,000 maximum, whichever comes first. The three year period starts on the date of card activation or 90 days after vehicle sale or lease commencement date, whichever is earlier. Fuel card is nontransferable. The Mirai is a hydrogen-powered fuel cell electric vehicle that must be fueled at hydrogen stations conforming to the latest Society of Automotive Engineers (SAE) hydrogen fueling interface protocol standards or laws that may supersede such SAE standards. Refer to the Mirai Hydrogen Stations Locator in the Fuel Station Function on the multimedia display, [www.toyota.com](http://www.toyota.com), or call Toyota customer service at 1-800-331-4331 for information on hydrogen fueling stations available to Mirai. **55.** Extra-cost color. **56.** Do not rely exclusively on the Rear Cross-Traffic Braking system. Always look over your shoulder and use your mirrors to confirm rear clearance. The system cannot prevent all collisions, and performance is dependent on road, weather and vehicle conditions. See *Owner's Manual* for additional limitations and details.

Toyota strives to build vehicles to match customer interest and thus they typically are built with popular options and option packages. Not all options/packages are available separately and some may not be available in all regions of the country. See [toyota.com](http://toyota.com) for information about options/packages commonly available in your area. If you would prefer a vehicle without any or with different options, contact your dealer to check for current availability or the possibility of placing a special order. Color(s) depicted may vary based on multiple factors, including ambient lighting and the format in which it is being viewed (e.g., computer, mobile device or print).

Some vehicles are shown with available equipment. Seatbelts should be worn at all times. For details on vehicle specifications, standard features and available equipment in your area, contact your Toyota dealer. A vehicle with particular equipment may not be available at the dealership. Ask your Toyota dealer to help locate a specifically equipped vehicle.

All information presented herein is based on data available at the time of posting, is subject to change without notice and pertains specifically to mainland U.S.A. vehicles only. Vehicles shown may be prototypes and/or shown with options. Actual models may vary.

## WARRANTIES

Every Toyota Car, Truck and SUV is built to exceptional standards. And that's not idle boasting. We back it up with these Limited Warranty Coverages:

**Basic:** 36 months/36,000 miles (all components other than normal wear and maintenance items).

**Fuel-Cell-System-Related Component Coverage:** Fuel Cell System components, including the Battery ECU, FC Air Compressor, FC Boost Converter, FC ECU, H2 tanks, FC PCU (Power Control Unit), FC System, HF ECU (H2 Fueling ECU), and Power Management ECU (HV ECU).

**Powertrain:** 60 months/60,000 miles (engine, transmission/transaxle, drive system, seatbelts and airbags).

**Rust-Through:** 60 months/unlimited miles (corrosion perforation of sheet metal).

**Emissions:** Coverages vary under Federal and California regulations. Refer to applicable *Warranty and Maintenance Guide* for details.

**FC Battery:** FC battery is covered for 10 years or 150,000 miles, whichever comes first. Warranty coverage is

subject to terms and conditions. Refer to applicable *Warranty and Maintenance Guide* for details.

**Accessories:** For Genuine Toyota Accessories purchased at the time of the new vehicle purchase, the Toyota Accessory Warranty coverage is in effect for 36 months/36,000 miles from the vehicle's in-service date, which is the same coverage as the Toyota New Vehicle Limited Warranty.

For Genuine Toyota Accessories purchased after the new vehicle purchase the coverage is 12 months, regardless of mileage, from the date the accessory was installed on the vehicle, or the remainder of any applicable new vehicle warranty, whichever provides greater coverage.

You may be eligible for transportation assistance if it's necessary that your vehicle be kept overnight for repairs covered under warranty. Please see your authorized Toyota dealership for further details.

For complete details about Toyota's warranties, please visit [www.toyota.com](http://www.toyota.com), refer to the applicable *Warranty and Maintenance Guide* or see your Toyota dealer.



Toyota drivers love to embrace new things and find new adventures. They just can't sit still. And proper vehicle maintenance is key to helping keep your Toyota safe, dependable and ready to explore. That's why we include a no cost maintenance plan with the purchase or lease of every new Mirai for 3 years or 35,000 miles, whichever comes first. 24-hour roadside assistance is also included for 2 years and unlimited miles. For all the details and exclusions, please call, visit online or stop by your local Toyota dealer today. Valid only in the continental U.S. and Alaska. Let's drive with confidence. Welcome to the ToyotaCare advantage.



For Toyota Mobility program details, go to [www.toyota.com/mobility](http://www.toyota.com/mobility) or call the Toyota Customer Assistance Center at 1-800-331-4331