

from Plymouth for 1975
The Small Fury



FURY SPORT

The excitement's all new. So is the luxury.



Fury Sport 2-Door Hardtop equipped with optional 15" urethane road wheels.

Let's suppose you're one of millions of Americans who've been waiting for a new kind of car. One that's not too big. Or one that's not disappointingly small.

The all new small Fury is your kind of car. Our drawing tells you best



of Fury's new-size dimensions. We've compared it in outline to a typical full-size American car. Immediately, you notice the difference in scale.

But you won't need a tape measure

to appreciate the alert, all-new styling that's yours to enjoy should the new small Fury be the car that fits your driving needs best.

The exterior is completely new and fashionably clean, with tasteful accents of bright metal trim. There's eager new beauty in the slope of the hood, and the sleek handling of the passenger and luggage compartments. In all, the all new Fury's proportions are ideally suited to a mid-size car.

The Fury's 2-door hardtops, the Fury Sport and Custom, shown on these pages, are right on the money

for those with a younger, fresher motoring point of view.

Both offer the same basic benefits you'll find in all Plymouth-built cars: all-welded Unibody construction, torsion-bar suspension system, front disc brakes, 7-step dip-and-spray process, Electronic Ignition System, new sound barrier applications, plus a satisfying choice of smooth, responsive 6-cylinder and V-8 engines totally in keeping with today's need for fuel conservation. But, of course, there's more to these two all-new hardtops than Plymouth's strong, silent treatment.

FURY CUSTOM

A fresh new motoring point of view.



Fury Custom 2-Door Hardtop exhibits nicely integrated rear bumper style.

Fury's styling changes include a number of fresh new colors. The 18 shades offered for '75 are each formulated to match the spirit of the new small Fury. Also, you can choose among 6 vinyl tops in white, parchment, black, gold, green and red. Each is selected to coordinate with your chosen body color.

The new chrome grille is set into a new fiberglass front panel giving an overall feeling of smoothly integrated design. There is also plenty of glass area and more satisfying vision.

Equally satisfying is the degree of quiet you can expect from these two

quality-built Furys. A number of components contribute to Fury's comfortable performance. Rubber mounts are used to isolate the front suspension cross member from direct body contact. Rubber clamps around the rear leaf springs help reduce road noise reverberation. The steering wheel is designed with a double coupling to cut down on vibration. And we've come up with strategically placed sound deadeners and sealers to minimize wind noise.

In keeping with the smaller-but-luxurious theme, such desirable options as sun roof, stylish road

wheels (including 15" sizes with steel-belted radial tires) and wheel covers help convey a spirit of vigor and road-worthiness that you'll want to try for yourself.

True comfort lovers will also want to consider Fury's optional air conditioning system. It has been improved over our 1974 design, providing 22% more airflow for more rapid cool down, more comfort for rear seat passengers. And cooling capacity has been raised 15%. All the more reason why you should drive a Fury Sport, or its companion Custom 2-Door Hardtop.

FURY INTERIORS

Count on them for a number of personal favors.



Rich Boca Raton cloth-and-vinyl bench seat with center armrest is yours to choose.

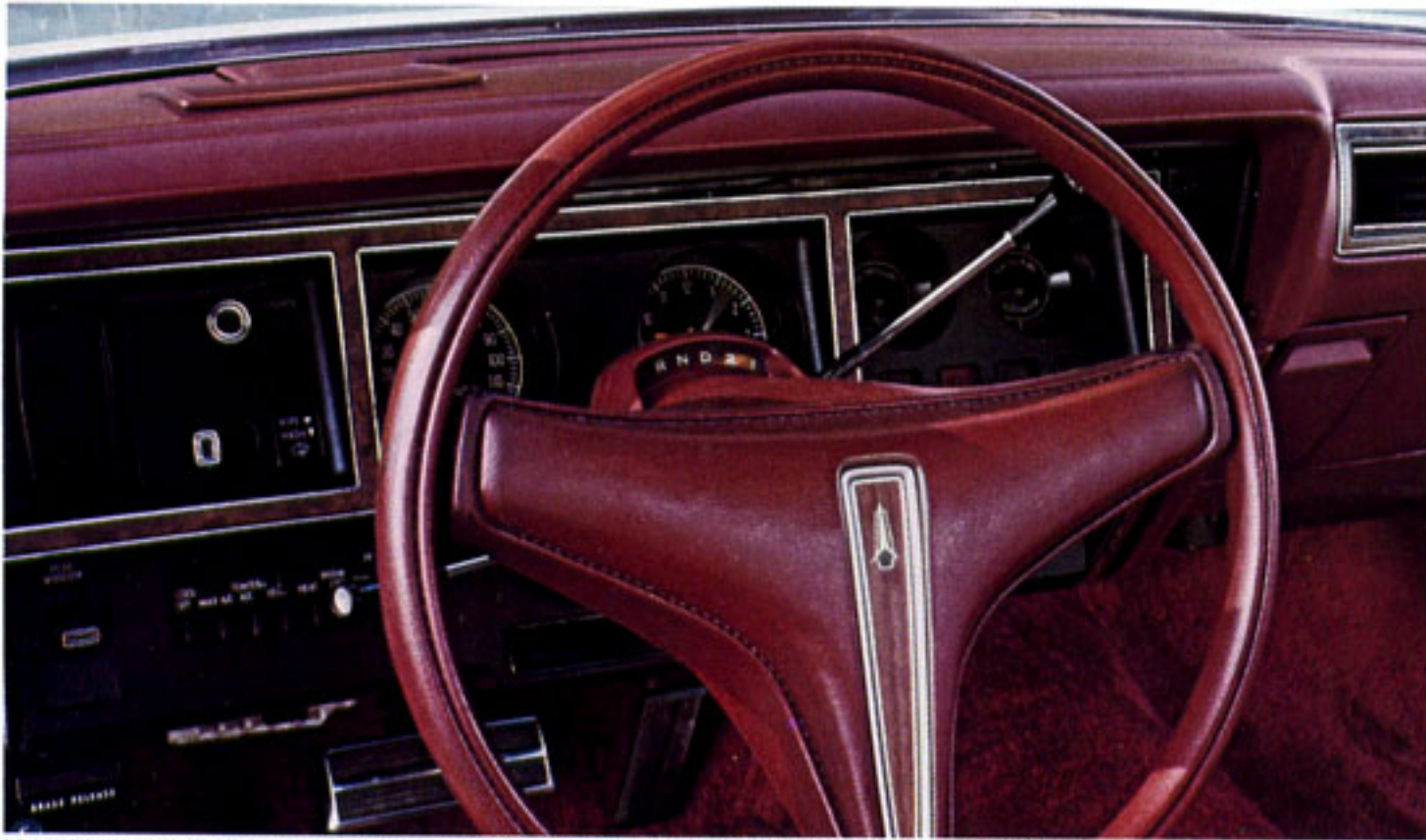

Handsome, readable Fury instrument panel with standard steering wheel.



This luxurious all-vinyl bucket seat design is standard on Fury Sport.

Just in case you equate lesser length with lesser luxury, take a look at these pages. And discover what our designers have done to fit the new small Fury into your life style.

You have three smart interiors to choose from in the Fury Sport. A well-tailored pleated vinyl, deeply contoured bucket seat is standard. And you get a choice of red, blue, green, black or gold to match your preferred exterior color. Plus white mixed with the same colors for variety. Additionally, there is our striking Boca Raton cloth-and-vinyl bench seat, an optional choice that comes in six equally smart colors. Also available is the cloth-and-vinyl bucket seat in gold, black and white.

We've reserved some tasteful seat combinations for the Fury Custom 2-Door Hardtop, too. Cloth-and-vinyl in 6 rich colors is standard. But you can choose an all-vinyl bench design with folding center armrest or the eye-opening Sundance cloth-and-vinyl with color-keyed shag carpet all 'round.

Both the Sport and Custom provide standard carpeting, the former a shag material, the latter, deep-pile. You also get a three-spoke steering wheel and instrument panel thoughtfully planned for safe, convenient use. In keeping with the Fury Sport's basic character, all instrumentation is housed in circular dials with white-on-black numerals for easy, accurate viewing.

A long list of power options is available to those who prefer even greater convenience. Power front disc brakes, power steering, power windows and power seats are recommended for the power-oriented buyer. Auto Speed Control is another highly regarded option which can save you fuel by automatically holding your Fury's speed constant whenever you feel the occasion demands.

There are also such options as a manually-operated sun roof and a selection of distinctive wheels and wheel covers you may want to choose.

Try the new small Fury at your dealer's. Look at it. Sit in it. Drive it. And discover how luxury has taken on new dimensions for 1975.

ROAD RUNNER

The others haven't caught up with it yet.

If you still want to get a kick out of a car, but still insist on plenty of luxury, Road Runner comes up with all the bright answers.

A long hood, a lower side body line for 1975 with a new chrome and black grille, up-and-over tape stripes keyed for use with a total of 18 colors, the Road Runner emblem on the rear deck lid, and rallye road wheels fitted with G70 x 14 raised white letter tires. Two other optional wheels are shown below, right.

The same youthful philosophy is just as apparent inside. All-vinyl bucket seats are standard and come in red, blue, green, black or gold. These colors also come with white trim. If you want, the same seat design is available in our highly original Sundance material. If you like a bench seat, you can get it in Sundance cloth, too. Color-coordinated carpeting is standard.

The instrument panel is a cluster design with readable gauges that'll get the approval of even the most diehard sports car buff. Space is reserved for an optional electric clock or tachometer and "low fuel" warning system—whichever you want to order. Our soft-rimmed "Tuff" steering wheel (shown in our illustration) is an option totally in tune with the spirit of the Road Runner image.

So much for looks. Now for Road Runner performance. Our husky, 318 V-8 is standard, though you can order the 360 or 400 cubic inch editions (the 400 2-bbl. is not available with the California Emissions Package). A 3-speed transmission is standard. TorqueFlite automatic transmission is available at extra cost. You get front disc brakes, sway bars at front and rear, heavy-duty suspension, Electronic Ignition System and all-welded Unibody construction. In fact, the basic good stuff you'd expect from Chrysler Corporation engineering.

You also get a quiet interior . . . and a choice of five radios—from AM to AM/FM multiplex stereo with 8-track tape decks—to make that quiet all the more enjoyable.

Road Runner, the Plymouth that makes you forget that mistaken notion . . . that cars can't be fun anymore.



Colorful Sundance cloth-and-vinyl bucket seats are available on the Road Runner.



Road Runner instrument panel features optional tachometer and sporty "Tuff" steering wheel.



14" Rallye wheel.

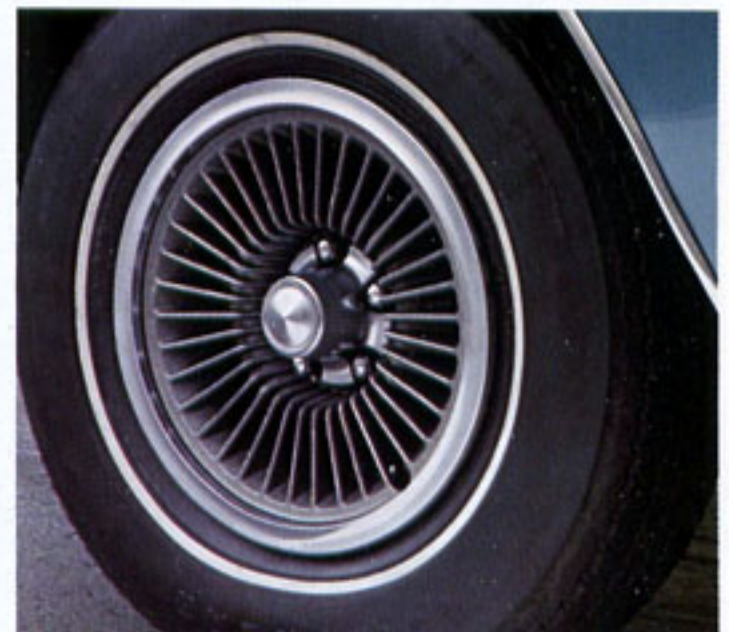

New 15" polycast urethane road wheel.



Road Runner—just to remind you driving can still be fun.

FURY SALON

A new level of luxury at a modest price.



Fury Salon—a most distinguished looking automobile—shown with optional wire-styled wheel covers.

We want you to take a quick look at the interior of our 1975 Fury Salon . . . then a quick look at the sticker price. Because we think you're then going to take a longer look at the interior.

No doubt about it. The Salon option is surely the plushiest of all the new small Furys. Standard interiors come in two stylish body cloths with center fold-down armrests—each as durable as they look. As an option you can select our soft velour (it wears longer than you'd imagine) just like the gold combination shown at right. Three other colors—blue, dark red, and green are yours to choose, each matched to your preferred body color.

A smart patterned cloth-and-vinyl is also available as an option.

You'll find that the Salon's standard carpeting is deep-pile shag. Another specially woven carpet lines the spacious luggage compartment to protect luggage and further shield you from road noise.

And, of course, we want you also to savor the impressive new exterior styling the Fury Salon exhibits for 1975.

There's a new sweeping look to the Salon. The hood slopes forward to a new front styling treatment that includes a rich-looking new grille, single headlamps, and parking lamps blended together in the Salon's new

molded fiberglass front panel. Bumpers are particularly well handled, providing a graceful, finished design at both front and rear.

In addition, careful and tasteful use has been made of chrome trim with bright metal at the wheel openings and running along the sill from wheel lip to wheel lip. Bright moldings are also used to accent the large glass area and headlamp housings.

In total, impressive, rich-looking style that is entirely worthy of the high level of trim you'll notice in the Fury Salon's luxurious interior.

For standard power, you can count on a smooth running 225 Six cylinder

or 318 V-8 fitted with Electronic Ignition System. And helping you put that power smoothly on the road are two Fury Salon optional features: its TorqueFlite automatic transmission and long-wearing 15" steel-belted radial tires.

A wide variety of other optional powered driving aids are on tap for those who relish automated comfort and convenience. Power steering, power front disc brakes, power windows, power seats and door locks are likely choices for the luxury-minded motorist. Auto Speed Control is another optional feature you'll appreciate, particularly on those long stretches of superhighway. To help you get the most you can out of today's more expensive fuel, our new Fuel Pacer System reminds you to take it easy on the gas pedal.

And just so you'll feel even more confident and comfortable behind the wheel of your Fury Salon, a number of Chrysler Corporation engineering niceties come as standard equipment.

The Salon's Unibody construction is all welded, a tight and strong structure made up of basic panels joined together in more than 4,000 places. The body is subject to our 7-step dip-and-spray process, too, to help fight corrosion.

Handling and ride are assisted by our torsion-bar suspension. Front disc brakes are standard. An Electronic Ignition System, which does away with the need for points and condensers, has proved to be a most popular innovation with those who have owned Plymouths equipped with this feature.

There are other more detailed improvements in the Salon, too. Generous glass area, for example. Wider wipe area for bad weather vision thanks to new, 18" wipers. Stronger, redesigned door latches. And a wonderfully quiet sound package complements all the plush interior features you can expect as standard when you select the luxurious Fury Salon.

All the outstanding advances we've discussed prompt us to offer a sensible suggestion: ask to drive the Fury Salon. You're going to find the value hard to believe.



Velour seats with matching vinyl trim emphasizes Salon's luxury environment.



Even the trunk and spare are carpeted in Salon.



Standard bumper guards.



Air conditioning—a popular option.

FURY CUSTOM SEDAN

For those who want plenty of value per mile.



Fury Custom 4-Door Sedan shown here in one of many striking metallic colors for '75.

We can think of thousands of American families who've been waiting for a sizeable, comfortable, roomy car at a price that will be as considerate of their budget as their driving needs.

Enter Fury Sedan. Exit the idea economy cars have to be economy-sized.

Fury Sedan brings you all the traditional, plus some new, Chrysler Corporation engineering ideas. All-welded Unibody construction, for example. Electronic Ignition System. Torsion-bar suspension. Detailed niceties like generous glass area and 18-inch wiper blades to provide safe bad weather vision, a wide 12" rearview mirror, strong and safer door latches, headliners made out of one-piece fiberglass for a neater, more finished look.

And of course, you get the lasting satisfaction of Plymouth's 7-step dip-and-spray process to help keep your investment in your Fury Sedan as secure as possible.

There are a number of other ways you can make your Fury Sedan an even more satisfying car to own and drive... with such worthwhile options as Auto Speed Control, and the new fender-mounted Fuel Pacer System.

Or you may want to consider equipping your Fury with long-mileage steel-belted radial tires—known for their ability to help conserve fuel and assist handling. All are designed to help extend the driving radius of your Fury's standard 25.5 or 20.5 gallon fuel tank with a 400 or 440 dual exhaust V-8.

Add to these energy-oriented features, the many optional convenience and comfort assists you can choose. Our well-proved TorqueFlite automatic transmission is one of them. So is air conditioning. And so are a number of power driving aids like power steering, power front disc brakes, power seats, and power windows... each designed for your family's total comfort and peace of mind.

Take our advice. Wait no longer for the ideal family-size car. It's waiting for you at your Plymouth dealer. Just ask for the Fury Sedan.

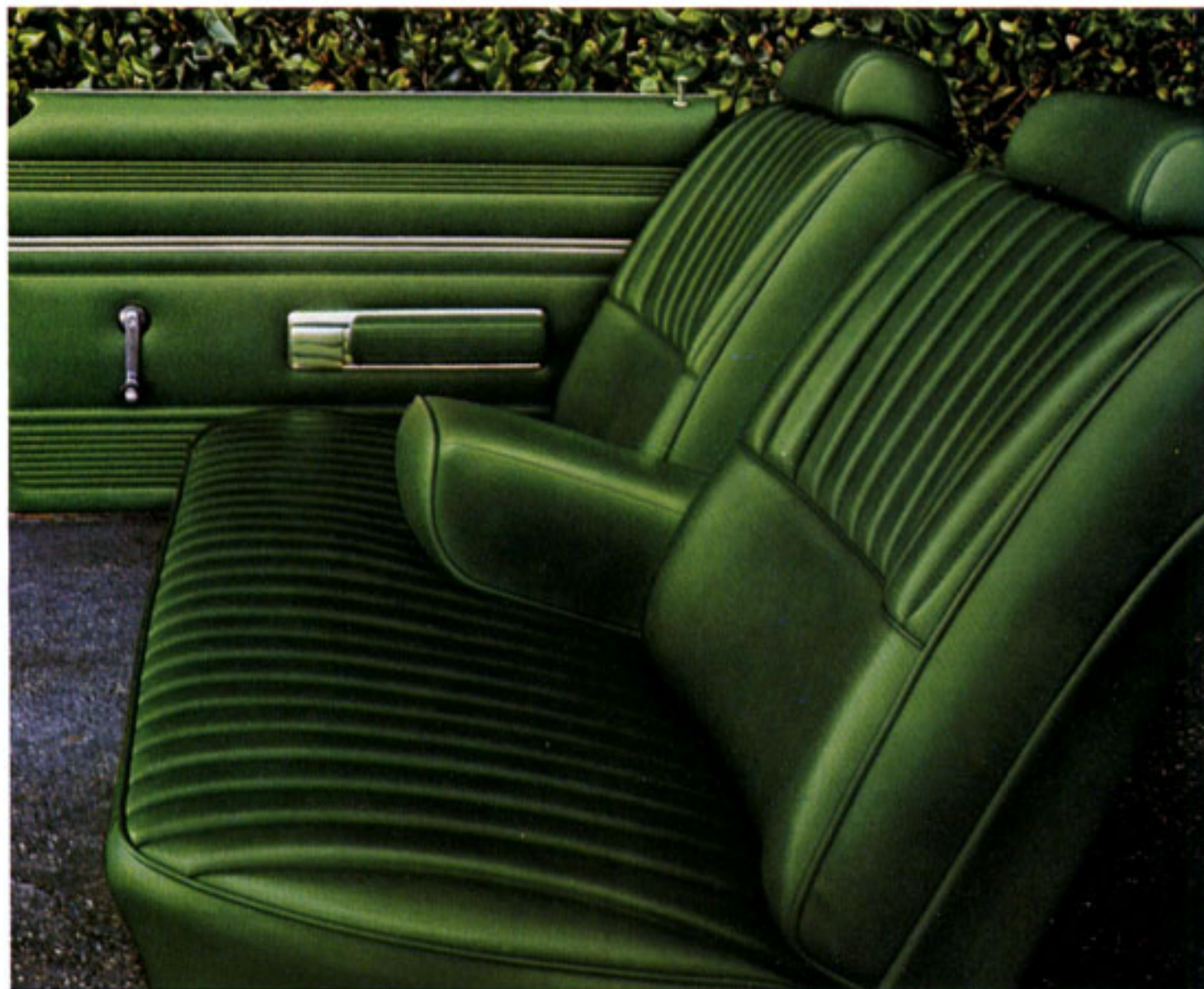

All-vinyl bench seat with center armrest is a practical and stylish Fury Custom option.



Fury Custom standard bench seat in cloth-and-vinyl shown here.

FURY OPTIONAL EQUIPMENT

How to add to your personal driving pleasure.

OPTIONS	Fury	Road Runner	Fury Custom 4-Door Sedan	Fury Custom 2-Door	Sport	Check List
Comfort Convenience						
Air Conditioning	0	0	0	0	0	
Automatic Speed Control	0	0	0	0	0	
Clock—Electric	0	0	0	0	0	
Console	N/A	0	N/A	N/A	0	
Defroster—Rear Electric	0	0	0	0	0	
Deluxe Sound Insulation Package	0	0	0	0	N/A	
Fuel Pacer System	0	0	0	0	0	
Gas Cap Locking	0	0	0	0	0	
Hood Release—Inside	0	0	0	0	0	
Horns—Dual	0	N/A	0	0	0	
Light Package	0	0	0	0	0	
Luxury Equipment Package	N/A	N/A	0	0	0	
Power Seats	0	0	0	0	0	
Power Brakes—Disc, Front	0	0	0	0	0	
Power Door Locks	0	0	0	0	0	
Power Steering	0	0	0	0	0	
Power Windows	0	0	0	0	0	
Radio—AM	0	0	0	0	0	
Radio—AM/FM	0	0	0	0	0	
Radio—AM w/8-Track Stereo Tape	0	0	0	0	0	
Radio—AM/FM Stereo	0	0	0	0	0	
Radio—AM/FM Stereo w/8-Track Stereo Tape	0	0	0	0	0	
Rear Seat Speaker	0	0	0	0	0	
Salon Package	N/A	N/A	0	N/A	N/A	
Speed Control	0	0	0	0	0	
Sun Roof	0 ³	0	N/A	0	0	
Tachometer	0	0	0	0	0	
Tinted Glass	0	0	0	0	0	
Undercoating and Hood Pad	0	0	0	0	0	
Ventilation—Strato	0	0	0	0	0	
Windshield Wipers—3-Speed	0	0	0	0	0	
Decor Dress-Up						
Decor Package Exterior	N/A	0	N/A	N/A	N/A	
Bumper Guards—Front & Rear	S	S	S	S	S	
Mirror—Inside Day/Night	S	S	S	S	S	
Mirrors—Dual Sport-Styled, Remote-Control	0 ³	0	N/A	0	0	
Mirrors—Remote-Control, Left	0	0	0	0	0	

OPTIONS	Fury	Road Runner	Fury Custom 4-Door Sedan	Fury Custom 2-Door	Sport	Check List
Decor Dress-Up (Cont.)						
Mirrors—Remote-Control, Left & Right	0	0	0	0	0	
Molding—Vinyl Body Side	0	0	0	0	0	
Pedal Dress-up	0	0	0	0	0	
Performance Hood Treatment	N/A	0	N/A	N/A	N/A	
Protective Rub Strips—Front	0	N/A	0	N/A	N/A	
Protective Rub Strips—Front & Rear	0	0	N/A	0	0	
Road Wheels—Rallye 14"	0	*	0	0	0	
Road Wheels—Chrome Styled 14" (Set of 4)	0	0	0	0	0	
Road Wheels—Styled Polycast 15" (Set of 5)	0	0	0	0	0	
Steering Wheel—Deluxe with partial horn ring	0	0	0	0	0	
Steering Wheel—Tuff	0	0	0	0	0	
Tape Stripes—Body Side	N/A	S	N/A	N/A	S	
Tape Deck Stripe (Tunnel Road Runner)	N/A	0	N/A	N/A	N/A	
Trunk Dress-up	0 ²	N/A	0	N/A	N/A	
Wheel Covers—Deluxe 14" and 15"	0	N/A	0	0	S	
Wheel Covers—Premier 14"	0	N/A	0	0	0	
Wheel Covers—Wire 15"	0	N/A	0	0	0	
Performance						
Axle Sure-Grip Differential	0	0	0	0	0	
225 Six	S	N/A	S	S	N/A	
318 V-8 Single Exhaust	S	S	S	S	S	
360 V-8 Single Exhaust	0	0	0	0	0	
400 V-8 Single Exhaust 2-V or 4-V	0	0	0	0	0	
400 V-8 4-V Dual Exhaust	0 ³	0	N/A	0	0	
500-ampere Battery	0	0	0	0	0	
Shock Absorbers—Heavy-duty	0	0	0	0	0	
Steel-belted Radial-ply Tires	0	0	0	0	0	
Suspension—Heavy-duty	0	S	0	0	0	
Transmission—3-Speed Manual Column Mounted 225 and 318 Only	S	S	S	S	S	
Transmission—TorqueFlite Automatic	0	0	0	0	0	

0—Optional S—Standard N/A—Not Available ¹Fury 2-door only ²N/A Fury 2-door ³N/A Fury 4-door

The wide choice of optional features shown on these pages is your surest path to greater satisfaction while you own the car.

Some examples:

The **Fury Family of Radios** includes push-button models in AM, AM/FM with 8-track stereo tape, AM/FM stereo, AM/FM Multiplex with stereo. All stereo sets come equipped with 2 front and 2 rear speaker setups. In view of the major noise isolation engineering that goes into every 1975 Fury, you can imagine the quality of sound available. **Fury Power Assists** provide a number of useful services. For '75, you can order **power door locks** that make it so much easier to lock all doors. **Power windows** permit you to control fresh air flow as you

would like it when you're at the wheel. **Power steering** is a wonderful aid in handling your Fury in parking situations. And Fury's optional **power front disc brakes** offer sure, smooth braking regardless of terrain and with minimum pedal pressure—something you'll appreciate in crowded traffic.

Timely economy measures:

Let's also talk about Fury's optional fuel-savers for '75. You'll be surprised how quickly **Auto Speed Control** can pay for itself. A simple push-button control permits you to set the speed you desire. **Auto Speed Control** will then hold that speed until you brake below the mph you've programmed.

Same for Fury's **Fuel Pacer System**. This new accessory is installed in the fender-mounted direction signal.

When it lights up, you're being asked to take it easier on the gas pedal . . . and thereby easier on gas consumption. Plymouth engineers have also figured out fuel-saving **rear axle ratios**. The lower the ratio number, the more economy you can expect.

Fury's **Wheel and Tire** story is interesting for '75, too. Two styles of road wheels, the rallye type and the "mag" design, are available on models taking the 14" wheel size. A new, bladed-style wheel is molded in super-tough polyurethane, then mated to the steel 15" rim. This material is easily cleaned and rust-free. And it looks great, too.

On the next page, you'll find other individual optional features as well as some we've already talked about.



Fury's new size is trailer-towing size.

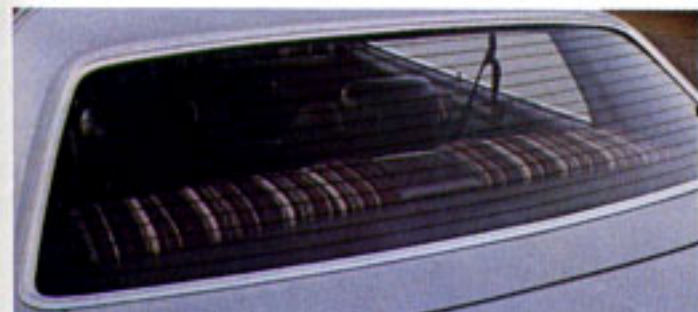

Electric rear window defroster.



AM/FM stereo with 8-track tape deck.



Bucket seat console.



Opt. wire-styled wheel covers.



Auto Speed Control. Simply press and set to desired speed.

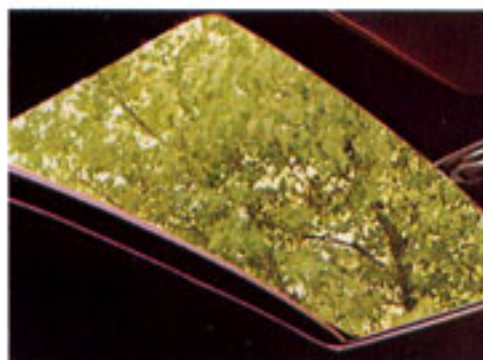

Manually-operated sun roof.



Fuel Pacer.

Trailer-Towing packages. We've got the right combination and equipment already worked out for your Fury—whether you plan to haul a lightweight (under 2000 lbs. fully loaded) trailer; or a heavyweight that hits the scales up to 6000 lbs. Ask your dealer or salesman which trailer package is right for your needs. Details in the 1975 Trailer-Towing Catalog.

Electric rear window defroster. A friend indeed when your local weather turns ugly. Thin wires sandwiched in the rear window heat up, get rid of ice or snow within minutes.

FM/Multiplex radio with 8-track stereo. Our finest of many fine radio systems for '75. Push-button tuning, tone, fidelity offer maximum listening pleasure.

Bucket seat console. If you choose bucket seats, this stylish integrated console can also be ordered. Contains the shift lever as well as locker space for traveling sundries.

Wire-styled wheel cover with radial tire. This wheel cover looks almost like the real thing. Beautifully designed, multi-spoke style adds a touch of flair to the Fury of your choice.

Auto Speed Control. Permits you to set the speed you desire . . . and hold it automatically. Particularly welcome on long trips, helps save fuel.

Fury sun roof. All the advantages of the convertible with all the benefits of sedan or coupe security. Fury sun roof is manually operated.

Fuel Pacer System. The Fuel Pacer is right in view on left front fender.

THE NEW FURY WAGONS



If you've been waiting for a smaller wagon that also has plenty of room, you'll want to look at the three Fury Suburbans. All three of these wagons combine the advantages of a smaller 117.5" wheelbase with enough interior room to meet the needs of most wagon buyers.

The Fury Suburban is ideal for those who seek a practical size wagon capable of handling cumbersome items—like a 4' x 8' sheet of paneling with tailgate closed.

We urge you to compare our Fury wagons. So you'll know for sure how wagons ought to be designed, ask for our complete 1975 Wagon Catalog.

ENGINEERING

Proves Fury is more than it appears to be.

When it comes to surface beauty, Fury's clean lines and roomy dimensions will stand the most demanding inspection. But we maintain that what lies beneath that beautiful exterior is just as important to those who've been waiting for the ideal American-size car.

Let's put a Fury together and find out why. Start with Unibody. It's a single unit structure held together by more than 4000 individual welds to make a solid, sturdy base for other typical Chrysler Corporation-engineered components. Like, for example, our Torsion-bar Suspension

System which employs bars that twist, rather than coils which compress... a different way to provide a comfortable, quiet and balanced ride over all road surfaces. You won't find torsion bars on any of Fury's domestic competition.

Remember, too, that a Fury is engineered to last. Fury's 7-step

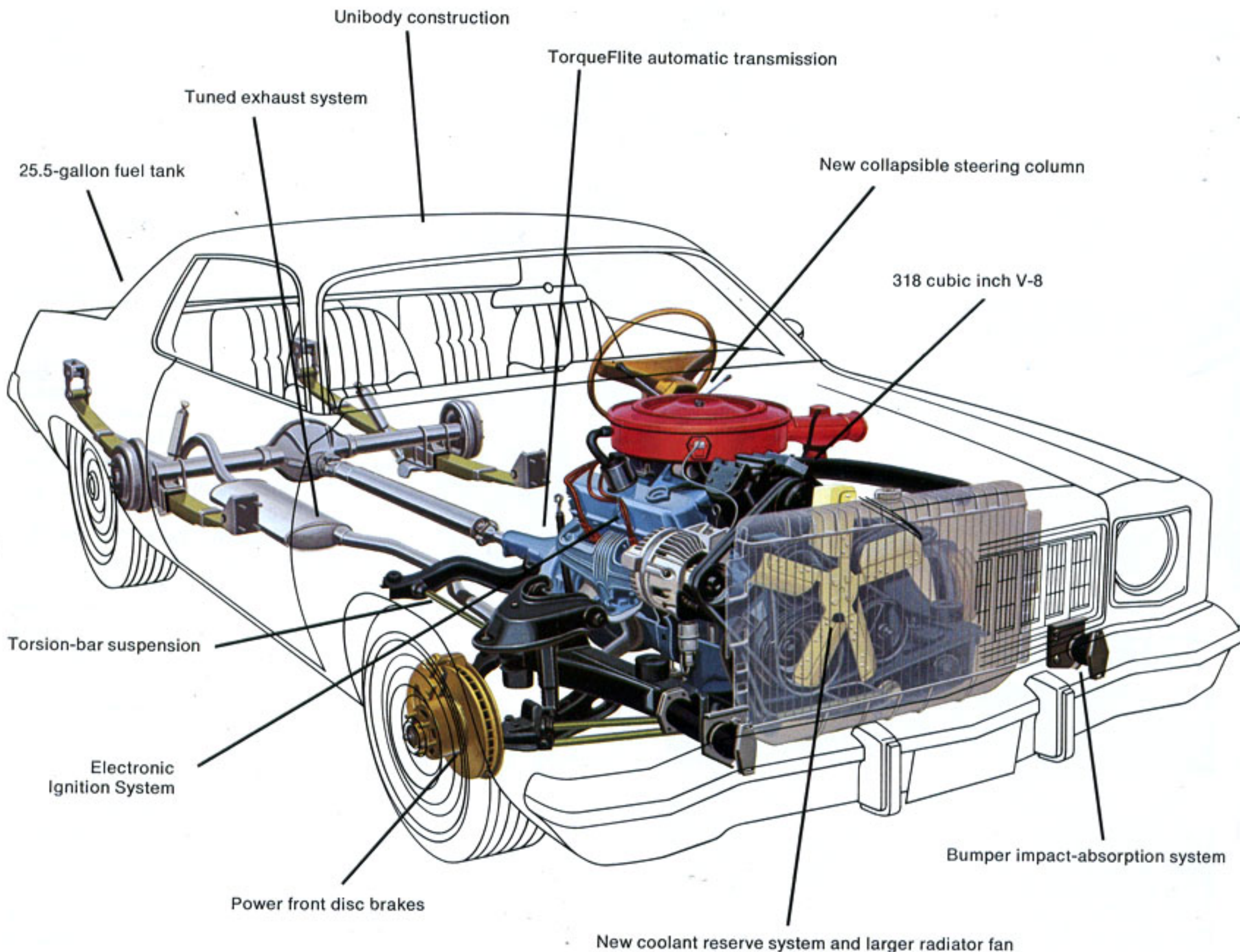

dip-and-spray process inhibits rust, provides a wonderful basis for the wide range of gleaming acrylic enamels you can choose for '75. Each Fury body also is sprayed with sound deadeners which along with strategically placed jute pads give you a degree of quiet you can appreciate only by driving the Fury of your choice.

This sort of dependability is also built into the Fury's electrical components. Our Electronic Ignition System delivers up to 35% more starting voltage than conventional systems for surer starts in bad weather. Plug life should be good for 30,000 miles, almost twice the mileage formerly recommended for a change to new plugs when the engine is operated with unleaded fuel. Such advanced thinking is also revealed in the solid state fidelity of the Fury's many optional radio models.

You'll also want to remember that

our smooth but rugged TorqueFlite transmission permits efficient conversion of power to the rear wheels. And that means, naturally, efficient use of today's expensive fuel.

For the safety of you and your passengers, Fury for '75 meets or exceeds the latest standards. The collapsible steering column, passenger restraint system, side door beams, front disc brakes (power-assisted on Fury Suburbans), and an impact-absorbing bumper system, including front and rear bumper guards which provide a measure of security that seems to be totally in keeping with the wonderfully quiet way a Fury moves about its business.

Sure, the small 1975 Fury, no matter what the model, looks great and performs efficiently. But the way it *feels* is all due to what its engineering team has done in the places you can't see. So when you buy Fury, you buy a lot of hidden value, too.



Long-life battery.

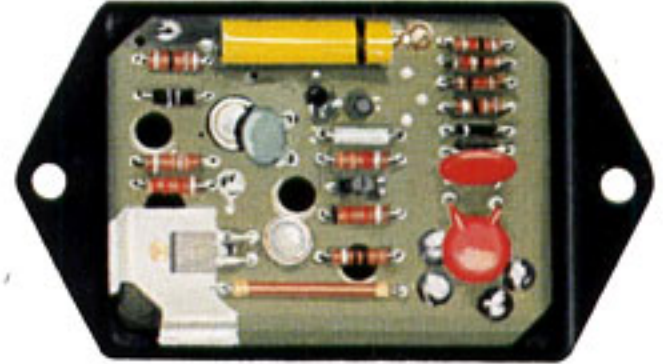

Electronic ignition.

The practical dimensions of the all-new small Fury.

Plymouth Fury 4-Door Sedan

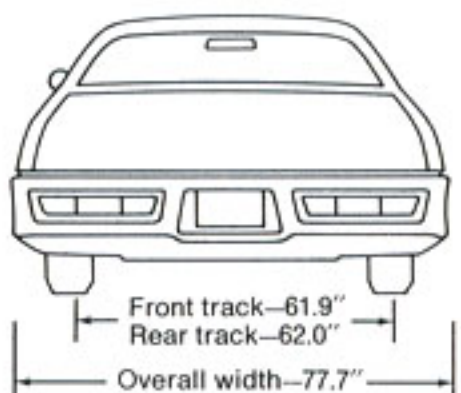
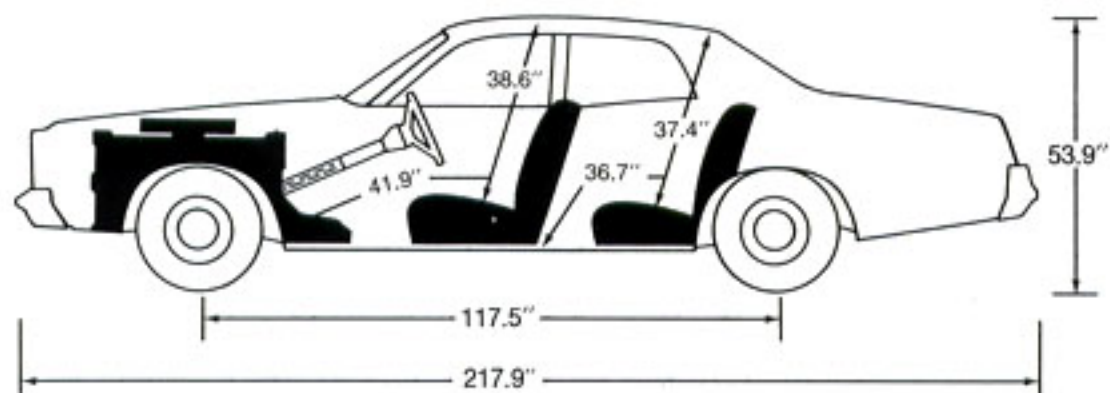

Plymouth Fury 2-Door Hardtop

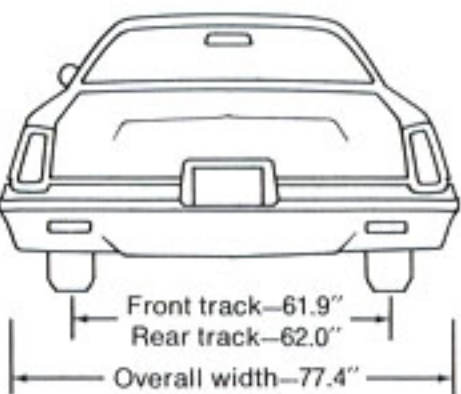
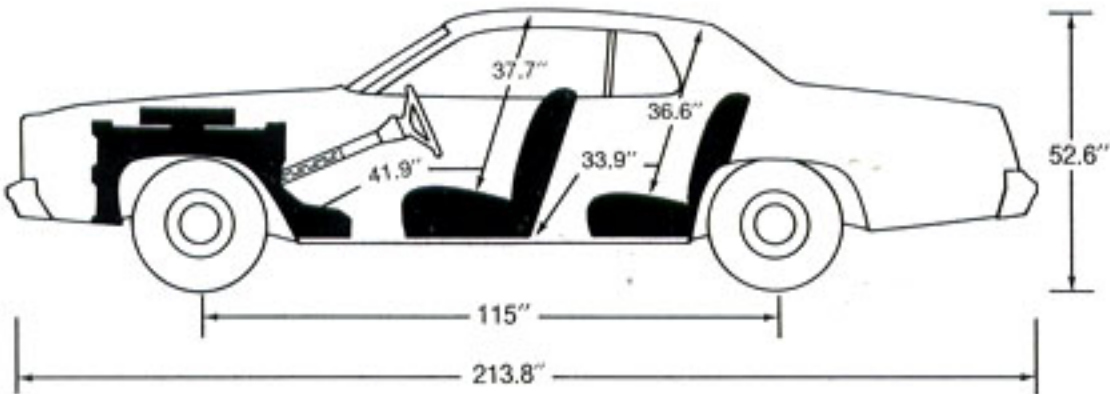

1975 STANDARD FEATURES

Fury Standard Features

(Fury, Fury Custom) Front and rear bumper guards • Hubcaps • Bias-belted tires • Color-keyed rubber floor covering (Fury Coupe and Sedan) • Color-keyed carpet (Fury Custom) • Front armrest with bright base (Fury Custom only) • Rear-seat armrests with bright bases and ashtrays (Fury Custom only) • Cigarette lighter (except Fury Coupe) • Glove box lock • Dome light • Soft coat hooks • Heater and defroster • Cleaner air system • 225 CID Six or 318 CID V-8 • Torsion-Quiet Ride • Front disc brakes • Electronic Ignition System • 3-speed fully synchronized manual transmission • Electronic voltage regulator • Front sway bar.

Fury Sport Standard Features

(Fury standard features plus these additions and substitutions) Deluxe wheel covers • Body side paint stripes • Bucket seats • Premium door trim panel • Special Fury Sport trim and

ornamentation • 318 CID V-8 standard • "Super-Quiet" sound package.

Road Runner Standard Features

(Fury Coupe standard features plus these additions and substitutions) Argent-painted 14" Rallye wheels with chrome hubs • Body side, roof and rear deck tape stripes • Road Runner interior trim and ornamentation • 318 CID dual-exhaust V-8 • Floor-mounted, three-speed, manual fully synchronized transmission • Heavy-duty suspension • Front and rear sway bars • Low-restriction dual exhaust system with chrome exhaust tips • 8¼" axle, 3.21 ratio • "Beep-Beep" horn.

Standard Safety Features

Fuel-tank impact protection • Keyless door locking • Side marker lights and reflectors • Back-up lights • 2-speed electric windshield wipers • Electric windshield washers • Dual-action safety hood latches • Parking lights that illuminate with headlights • Safety door latches and hinges • Thick-

laminated safety glass windshield • Safety skid-type windshield header • Intrusion protection roof structure • Safety-Rim wheels • Passenger-restraint system with starter interlock • Flame retardant interior material • Turn signals with lane-change feature • Locking steering column • Energy-absorbing instrument panel, front seat-back and armrests • Seat belts, all seating positions • Inside door locks • Cushioned sun visors with center supports • Dual braking system with warning lights • Hazard warning light system • Head restraints, 2 front • Locking latch on all folding front seat-backs • Energy-absorbing steering column • Glove box door latch • Recessed door handles • Inside rearview mirror and left outside rearview mirror • Bumper impact system—front and rear • Side door beams.

For information on Fury Wagons see the 1975 Plymouth Station Wagon Catalog.

1975 PLYMOUTH FURY EXTERIOR COLORS



NOTE: Due to occasional printing irregularities, the above colors may vary slightly from actual hues. See your Plymouth Dealer for accurate color chips.

All product illustrations and specifications are based on authorized information. Although descriptions are believed correct at publication approval, accuracy cannot be guaranteed. Some of the equipment shown on product illustrations is optional, at extra cost. Chrysler Motors Corporation reserves the right to make changes from time to time, without notice or obligation, in prices, specifications, colors and materials, and to change or discontinue models.



Plymouth

