

**1975 small cars from Plymouth**

# **Duster/Valiant**

# GOLD DUSTER

Proves a compact needn't look like one.



The Gold Duster . . . as rugged as it is good looking.

Yes, Gold Duster's 108" wheelbase qualifies it as a compact. But, to many who drive it for the first time, Gold Duster won't "feel like a compact."

The new grille treatment, with smoothly integrated parking and turn indicator lamps, scores high in the styling department . . . adds to Gold Duster's impressive good looks.

Maybe that's why it has enjoyed such overwhelming popularity with those who prefer their cars to be as spacious as they are stylish and economical.

Gold Duster offers truly amazing value. When you tote up all its standard equipment and features, you'll begin to wonder why so many smaller imports (as well as plenty of domestic competitors) don't measure up to Gold Duster value. For example, you get a choice of our solid, smooth 225 CID Slant 6 or 318 CID V-8 with all-synchromesh 3-speed transmission . . . torsion-bar suspension . . . all-welded Unibody construction . . . Electronic Ignition and voltage regulator for the extremes you expect of

American weather. Add to this loop-pile carpeting . . . and niceties like a cigarette lighter . . . or such basics as our thorough, dip-and-spray body process that helps fight corrosion. There's a total of 16 lustrous colors (five of them new for '75). Also standard: gold vinyl body side molding or stripe, canopy vinyl roof, whitewall tires, wheel covers, day/night rearview mirror and deluxe sound insulation.

This same kind of attention has been paid to Gold Duster interiors.



The split-back all-vinyl bench seat is standard.

The all-vinyl split back seat is standard and comes in five colors: gold, green, blue, parchment and black. Cloth-and-vinyl bench seats with center armrest or all-vinyl bucket seats are available with black or white on black color motif.

The instrument panel reflects our desire to make your driving more enjoyable, too. Controls are placed for easiest use. The three-spoke steering wheel is color-keyed to the interior trim. The optional manually-operated sun roof can be counted on to make a sporty contribution to your driving enjoyment.

One final word . . . about our very special Space Duster Pak. It's an option that readily converts your Gold Duster (as well as other Duster models) into an even more versatile car. You get mini-wagon carrying capacity by folding the rear seats down for a carpeted cargo area measuring 6½ feet long. When the security panel remains in place, you still enjoy a large trunk area in which your luggage remains concealed.



Duster's functional instrument panel.



Manually-operated sun roof.

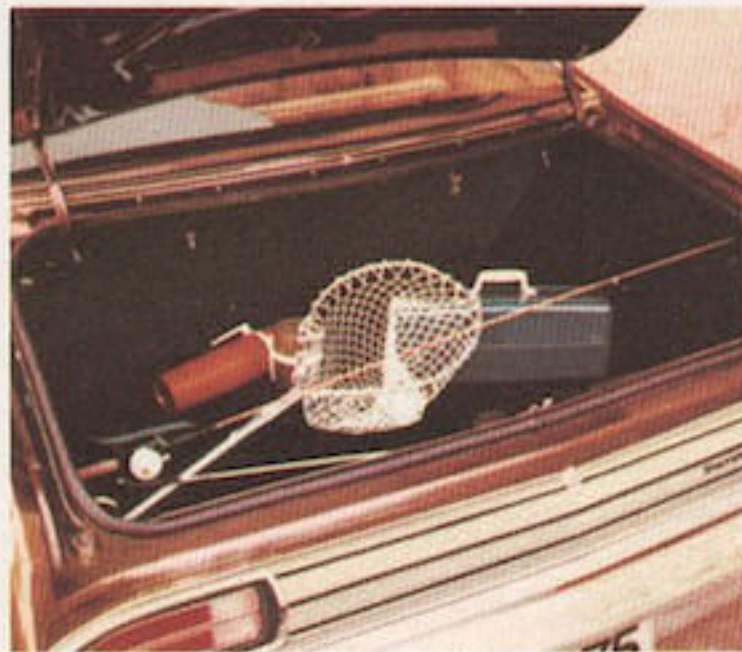

Space Duster Pak with security panel in place.



Space Duster Pak fully extended.

## DUSTER CUSTOM

For people who prefer efficiency with flair.



Smart good looks at a desirable price—this is the Duster Custom.

Plenty of well-planned space for five people and luggage. Plenty of efficient power from your choice of a 225 CID Six or a smooth 318 CID V-8. All the advantages of Plymouth's years-ahead engineering you'll find in greater detail on pages 14 and 15 . . . features like Electronic Ignition, torsion-bar suspension, and Unibody construction. Add to this Duster Custom's basic dimensions, a trim 108" and an overall length of 196.1"—with the kind of interior room that's immediately apparent when you and

as many as four others try this smart compact on for size. And there's a tasteful lineup of colors and interiors. That's what we mean when we say there's a big difference between a small car . . . and a small car from Plymouth. Like our Duster Custom.

A basic clue to the Custom's space planning is its big choice of interior seat designs and color-trim selection which we describe in greater detail on pages 10 and 11.

But what you'll most appreciate are the major steps we've taken with

Duster to provide measurable driving economies. Duster's engines are noted for their dislike of gas station pumps. In addition, we offer rear axle ratios designed to get the most efficient use out of your chosen engine/transmission combination. A 2.76 ratio is standard with the 225 Six, while the 318 V-8 with TorqueFlite comes with a 2.45. Since a lower numerical ratio promotes greater fuel economy, you save from the very moment you start putting the miles on your '75 Duster.

# DUSTER

It's what most small cars are trying to be.



Clean good looks—the popular Duster.



The sporty car lives! Duster 360.

When you take a really good look at Duster's competition, either imported or domestic, you suddenly realize that our basic Duster comes on big and strong. In everything but the price.

Maybe this is the reason Duster hangs on to its value so well around the used car lots. Now, most people don't buy a car only because it makes a good trade; but it ought to be a serious consideration. Besides, there's so much more to Duster while you own it.

Duster's spaciousness, to begin with, reveals dramatically that it's a car for American-size people. Seats are wide, soft and comfortable. You don't feel stuffed in as you might in many of the sub-compacts presently on the market. Thanks to plenty of trunk space, the same goes for your luggage. Think of this when you size up the smaller compacts. And of course, for a modest extra outlay, you can specify any number of Duster quality accessories or optional equipment to add to its comfort and convenience (see list on pages 12 and 13). You can, in effect, build your Duster just about the way you want it—something else to think about when you're trying on a mini-import.

**The toughest Duster.** The Duster 360 remains unabashedly a smart-looking, well-mannered road car. You'll find the 360 V-8 that powers it is quite in keeping with Duster's sporting image. From the outside, the 360's unique new tape striping, E70 x 14" tires and beefy road wheels provide easy identification of its sporting nature. Out of sight is the rest of the careful engineering that accompanies the 360 V-8 power source: dual exhausts (except in California), heavy-duty suspension and shocks, front sway bar and three-speed automatic transmission. A totally satisfying car for the driver who'd like a little something more—without unduly compromising the budget. Of course, if you're looking for a few extra-special touches for your Duster 360, there's a number of options described on pages 12 and 13.

# VALIANT BROUGHAM SEDAN AND HARDTOP

Styled like a luxury European. Priced well below one.



The Brougham 4-Door Sedan—the quality car for modest budgets.

Call it what you will. But when you can order a car with rich velour bucket or bench seats, deep-pile nylon carpeting, a vinyl roof color-keyed to your interior decor, premium trim fittings, thoughtful storage pockets in the back of the seats, sound insulation, power steering, color-keyed wheel covers, a distinctive die-cast hood ornament and your choice of smooth and efficient 225 Six or 318 V-8 engine with TorqueFlite automatic transmission—all at a price far less

than most luxury cars—there's obviously been a noteworthy breakthrough in the luxury car market.

The Valiant Brougham 4-Door Sedan is one very superior automobile—to look at, to relax in, to drive around. So is the similarly equipped Brougham 2-Door Hardtop—Plymouth's luxury offering to those who prefer a 2-door edition of this luxury concept.

There's plenty else to convince you the Brougham means luxury.

Small things. A full complement of courtesy lights. An interior hood release. A cigarette lighter. A day-and-night rearview mirror. A remote, left-hand outside mirror. Simulated wood-grain inserts on the instrument panel. Color-keyed belts. Carpeted trunk. And typically, an AM radio. Things you associate with far more expensive cars, all thoughtfully placed at your disposal . . . in a car you can reasonably afford.

The Brougham's thoughtfulness



Rich velour cloth with vinyl trim keynotes the interior.

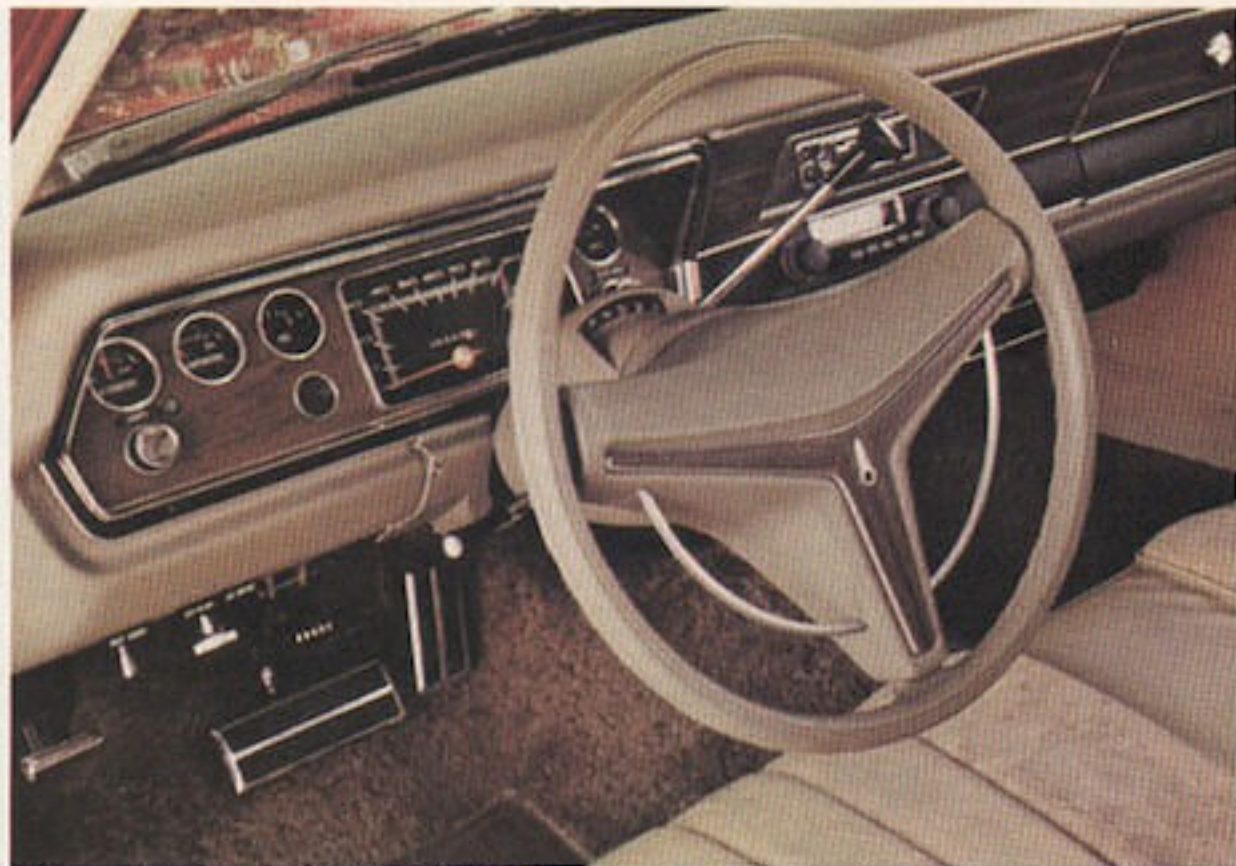

Deluxe steering wheel highlights Brougham's instrument panel.



The Brougham 2-Door Hardtop—for those with sportier tastes.

doesn't stop there. It also offers you all the long term benefits of Chrysler Corporation engineering. For example, all-welded Unibody construction. Fast, sure starts and long spark plug life with our Electronic Ignition System. You enjoy the balanced precision of torsion-bar suspension. And a superb rust preventative process makes an ideal base for the Brougham's distinguished exterior color selection.

Even with this outstanding list of new features and equipment, the

Brougham's particularly quiet way of going is sure to appeal to those who appreciate solid comfort. A most comprehensive system of sound control has been built into each of these fine cars—both 4-Door Sedan and 2-Door Hardtop models. Each part of this sound "package" relates to the other so that your driving may be as relaxing, as satisfying as possible. Doors and windows have been fitted with new seals. Silencers and deadeners have been placed in the

roof, cowl, hood, rear shelf, doors and rear quarter panels, on the floor pan in the trunk area. Critical components such as the engine, steering column, propeller shaft and exhaust system have received special attention in order to perform as quietly as one might expect of a true luxury car.

We urge you to take a specially close look at the 1975 Brougham. See if it doesn't win your vote as the outstanding luxury value of the year.

# VALIANT CUSTOM

New member of a long respected family.



Clean lines of Valiant Custom 4-Door Sedan are accentuated by smart vinyl roof.

Obviously, it isn't as important how long a car has been successful in the marketplace as it is *why* it has managed to become one of America's favorites among all compacts.

In the course of fifteen years the name Valiant has always been associated with the kind of value you'd expect of bigger, more expensive cars. The new Valiant Custom is a case in point. Begin with Unibody construction. The solid all-welded main structure is designed to resist the rattles and shakes. A torsion-bar

suspension system that makes the 111" wheelbase Valiant a pleasure to handle on the superhighways or in the mountains. Two standard engine choices—Valiant's 225 Slant 6 or its small-block 318 V-8. And for '75, the Valiant confirms its solid reputation for durability with a proven Electronic Ignition System (including an electronic voltage regulator) that obsoletes points and condensers, prolongs plug life with use of no-lead fuel and offers plenty of starting "punch" for those frigid mornings.

Through the years, too, Valiant has been a remarkably comfortable, roomy car. For '75, the Custom provides a superb range of seat styles and materials to choose from. Carpeting, the rich-looking, long-wearing loop-pile kind, is standard. And many of the optional comfort and convenience features we present on pages 12 and 13 are available for your consideration.

We feel Valiant Custom is the very finest of compacts to start with. But there's no reason why you can't make it even finer with your own touches.



# SCAMP AND VALIANT SEDAN

Good sense in two stylish versions.



The Scamp with vinyl roof . . . stylishly compact at modest cost.



The Valiant 4-Door Sedan . . . you'll like it for all it's worth.

## **The Scamp 2-Door Hardtop.**

Let's talk about Scamp first. Very trim and tidy on its 111" wheelbase, Scamp's good looks come in one basic hardtop configuration. Scamp's sturdy engineering includes as standard all the plus features of Chrysler Corporation pioneering concepts: a rich-looking, highly functional instrument panel; all-vinyl, pleated bench seats in five colors—blue, green, gold, black or parchment—and your choice of 16 exterior colors. Starting there, you can build a Scamp any way your

budget or your fancy suits you. For example, you can order an entire package including a vinyl roof, white-wall tires, full wheel covers, power steering, AM radio, remote-control rearview mirror, special insulation and interior trim, a number of other convenience extras most people want anyway, and you get TorqueFlite automatic transmission as standard.

## **The Valiant 4-Door Sedan.**

If you prefer the convenience of four doors, at a price that is as surprising as it is reasonable, the Valiant Sedan

makes a most logical choice. Again, Chrysler Corporation engineering is the basis for this Valiant's remarkable story. Exterior and interior color and trim combinations are sure to satisfy.

For power, either the 225 Six or the 318 V-8 is standard. You can decide which you'd rather have. On pages 12 and 13, we go into greater detail about the many worthwhile options you can specify for your Valiant. You'll find each a perfect complement to the basic design value that makes Valiant America's most sought after compact.

## DUSTER/VALIANT INTERIORS

You relax in style, comfort and wonderful quiet.

Once you sit behind the wheel, or test the rear seat of one of our Dusters or Valiants, you detect that some very special thinking has been reserved for you and your passengers. The atmosphere is quite unlike what you expect of a compact: roomy, airy, comfortable, color-coordinated. Like a well decorated room.

Once on the road, you understand an even more important asset . . . the quiet of these cars. These are interiors in which you can hold a normal conversation at highway cruising speeds, enjoy your radio or relax with a minimum of outside distraction. For this, you can thank the major sound insulating effort carried out by Chrysler Corporation engineers . . . one that returns a far greater measure of enjoyment than a Duster or Valiant price would indicate.

Of course, there's no way to photograph the quality of silence. But we think the views of the interiors shown on these pages are sure indications of the luxury we're talking about . . . with the kind of quiet you'll appreciate during your first test drive.

### Duster Interiors

As standard you get a cloth-and-vinyl bench seat available in green, black and gold. Or, if you choose, there's a long-wearing, easily cleaned, all-vinyl design that comes in blue, green, parchment, black and gold.

### Duster Custom and Scamp Interiors

An all-vinyl bench seat comes as standard. Its rich good looks can be had in blue, green, parchment, black, or gold—whichever coordinates best with the body color you select.

If you like, you can choose a vinyl split-back bench seat with center armrest for your Duster Custom. And you can order it in green, black, gold or parchment. Or, there's a cloth-and-vinyl in parchment. Also, you can order bucket seats for your Scamp Hardtop. They're all-vinyl and come in black, or black and white combination.



Optional Duster Caravan cloth-and-vinyl split bench seat design.



Full bench seat design in cloth-and-vinyl is standard on Valiant Custom.



Brougham's velour and vinyl trim bucket seats are standard.



Cloth-and-vinyl split bench. Optional Duster Custom and Scamp.



Duster's optional cloth-and-vinyl decorator special bucket seat.



All-vinyl split bench seat with folding armrest is a Gold Duster option.

### Valiant and Valiant Custom Interiors

The Valiant offers a scuff-resistant, pleasingly designed vinyl bench seat as standard. Durable and easily-cleaned, it comes in green, black and gold. On the Valiant Custom, there's a good looking cloth-and-vinyl bench seat as standard which you can get in green, blue, parchment and gold. At only slight extra cost, a smart all-vinyl split-back bench seat with center armrest is available in green, parchment, black and gold.

### Valiant Brougham Interiors

The ultimate seat in the style of a

quality European car—at a price you can afford. The super luxurious velour cloth-and-vinyl design comes in two versions: comfortably contoured bench or bucket seats. The latter are standard for both 4-Door Sedan and 2-Door Hardtop. The bench can be ordered at no extra cost. You'll find it difficult to reconcile the rich look and feel of this velour cloth with the Brougham's reasonable price. And you'll be pleased to know this velour seat can be ordered in three elegant colors: a new and sensational red, green or parchment.

### Summing Up

Like all other Duster and Valiant components, major or minor, these 1975 interiors are a superb example of outstanding decor built to standards that encourage long life and satisfying comfort. As you might expect, all materials and carpeting have been chosen with care. Factors of wearability have been as conscientiously considered as the matching of interior fabrics to the exterior color you prefer. And, of course, our designers have gone to great pains to deaden sound and promote quiet.

# DUSTER/VALIANT OPTIONS

How to add extra value to basic value.

Options	Duster	Valiant	Scamp/ Valiant Custom	Duster Custom	Duster 360	Valiant Brougham	Check List
<b>Comfort/Convenience</b>							
Air Conditioning	0	0	0	0	0	0	
Cigarette Lighter	0	0	S	S	S	S	
Console	0	N/A	N/A	0	0	N/A	
Defogger—Rear Window	0	0	0	0	0	0	
Defroster—Electric—Rear Window	0	0	0	0	0	0	
Deluxe Sound Insulation Pkg.	0	0	0	0	0	0	
Disc Brakes—Manual—Front	0	0	0	0	N/A	S	
Disc Brakes—Power—Front	0	0	0	0	S	0	
Fuel Pacer	0	0	0	0	0	0	
Hood Release—Inside	0	0	0	0	0	S	
Horns Dual	0	0	0	0	0	S	
Lock Glove Box	0	0	0	0	0	S	
Lock Gas Cap	0	0	0	0	0	0	
Light Package	0	0	0	0	0	S	
Power Steering	0	0	0	0	0	S	
Radio—AM	0	0	0	0	0	S	
Radio—AM/FM	0	0	0	0	0	0	
Rear Seat Speaker	0	0	0	0	0	0	
Space Duster Pak	0	N/A	N/A	0	0	N/A	
Speed Control Automatic	0	0	0	0	0	0	
Sun Roof Manual	0	N/A	0	0	0	0 <sup>1</sup>	
Tinted Glass All Windows	0	0	0	0	0	0	
Tinted Glass Windshield Only	0	0	0	0	0	0	
Trailer-Towing Package	0	0	0	0	0	0	
Undercoating	0	0	0	0	0	S	
Windshield Wipers—3-speed	0	0	0	0	0	S	
<b>Decor/Dress-up</b>							
Bumper Guards—Front & Rear	S	S	S	S	S	S	
Carpets	0	0	S	S	0	S	
Door Edge Protectors	0	0	0	0	0	0	
Mirrors Dual Sport Styled	0	N/A	N/A	0	0	N/A	

Options	Duster	Valiant	Scamp/ Valiant Custom	Duster Custom	Duster 360	Valiant Brougham	Check List
<b>Decor/Dress-up (Cont.)</b>							
Mats—Accessory Floor	0	0	0	0	0	0	
Mirror Remote-control, Left	0	0	0	0	0	S	
Mirror Day/Night Inside	0	0	0	0	0	S	
Molding Sill	0	0	0	S	0	S	
Molding—Vinyl Side	0	0	0	0	0	0	
Molding—Drip Rail	0	0	S	S	S	S	
Molding—Upper Door Frame	N/A	0	0 <sup>2</sup>	N/A	N/A	S	
Molding—Wheel Lip	0	0	0 <sup>2</sup>	S	0	S	
Steering Wheel—Tuff	0	0	0	0	0	0	
Steering Wheel—Deluxe	0	0	S	S	0	N/A	
Tape Stripe—Body Side (Perfor.)	0	N/A	N/A	0	S	N/A	
Tape Stripe—Body Side Wide	0	N/A	N/A	0	N/A	N/A	
Tape Stripe—Lower Deck	0	N/A	N/A	N/A	S	N/A	
Tires—Whitewalls	0	0	0	0	0	S	
Tires—Raised White Letter	0	0	0	0	0	0	
Tires—Steel-belted, Radial-ply	0	0	0	0	0	0	
Wheel Covers—Deluxe 4	0	0	0	0	0	S*	
Wheel Covers—Wire 4	N/A	N/A	N/A	N/A	N/A	0	
Road Wheels—Rallye	0	0	0	0	0	N/A	
<b>Performance</b>							
225 CID 6-cylinder engine	S	S	S	S	N/A	S	
318 CID 8-cylinder engine	S	S	S	S	N/A	S	
360 CID 8-cylinder 4-barrel	N/A	N/A	N/A	N/A	S	N/A	
Battery—500 ampere Long Life	0	0	0	0	0	0	
Heavy-duty Suspension	0	0	0	0	S	0	
Sway Bar Front	0	0	0	0	S	S	
Transmission—3-speed manual Floor-mounted	0	0	0	0	N/A	N/A	
Transmission—3-speed manual Column-mounted	S	S	S	S	N/A	N/A	
Transmission—4-speed Manual	0	N/A	N/A	0	N/A	N/A	
Transmission—TorqueFlite Auto	0	0	0	0	S	S	

\*Luxury Covers 0—Optional S—Standard N/A—Not Available <sup>1</sup> 2-door only <sup>2</sup> 4-door only

Your personal car-owning experience has most likely conditioned you to the kind of accessories and equipment you'll want on your new Duster or Valiant.

For that reason, we want you to know about the satisfying coverage Duster and Valiant provides when it comes to investing in optional equipment. **Investing in economy.**

Economy takes on some very real new dimensions these days. And there are a number of ways to make your Duster or Valiant an even thriftier car over the course of ownership. You'll find our **Auto Speed Control** can be a big help to many drivers in holding down fuel costs. Auto Speed Control steadies your cruising speed, automatically maintains the figure you've pre-set by simply pressing a button. The steadier

the speed, the better mileage you can expect. Same applies to our new **Fuel Pacer System**. This warning device (you order it with our light package) is installed on the left front fender turn-signal indicator, flashes a light when your foot gets too heavy on the pedal under acceleration. **Lower Numerical Axle Ratios** can also help deliver better mpg. And, generally speaking, the lower the numerical ratio, the more thrifty your car becomes.

#### Investing in comfort.

Your driving day is a more comfortable one with a number of important optional features. The Duster/Valiant **Air Conditioning System** is a prime example. Comfort levels can be chosen to easily maintain the temperature you require. Cooling air shields you from heat, of

course; but the system is even more welcome to allergy sufferers or to those who appreciate the peace and quiet that comes with "windows-up" motoring. Our **Deluxe Sound Insulation package** is standard on the Valiant Brougham, available on all other models for '75. It delivers comforting relief from the disturbances you're going to encounter in today's busy traffic. And these two sound barriers create an ideal environment for radio listening—whether your choice be AM (standard on the Valiant Brougham) or AM/FM.

#### Investing in convenience.

You'll enjoy the power features Duster/Valiant puts at your disposal for '75. One test drive will convince you of the benefits of Chrysler-engineered **Power Steering** and



We're ready for trailer-towing questions.



Automatic Speed Control.



Air conditioning is increasingly popular.



Fuel Pacer System.



Our AM/FM push-button radio.



Electric rear window defroster.



Rallye road wheel.



Inside hood release.

**Power Front Disc Brakes.** The handling is complemented by the smooth, stopping power generated by these highly popular options. There are other conveniences you'll be glad you selected. Like the **Electric Rear Window Defroster**, which saves you the grief of scraping and chopping at ice or snow accumulation, gives you a frost-free window in a matter of minutes. Or you may prefer the rear window **Defogger** when excessive humidity causes you a vision problem. Many owners are also completely sold on our **Inside Hood Release** that helps protect your engine compartment from easy theft. Many, too, like the convenience of a left-side **Remote Outside Rearview Mirror**, for the convenience it provides in all driving conditions. And for ultimate convenience, we suggest once again the wagon-like carrying capacity of our **Space Duster Pak** conversion.

Duster/Valiant options. Each makes your driving that much more worthwhile. Today. And at trading time.

#### Trailer Towing

Every Duster/Valiant fitted with TorqueFlite and front disc brakes is fully capable of lightweight class trailer-towing duty. Which means you can haul a loaded trailer weight of up to 2000 pounds with our recommended A34 Light Duty Towing Package. Be sure to ask your dealer about details of this reasonably priced and increasingly popular option. It's all in our separate '75 Trailer-Towing Catalog.

## PLYMOUTH TRAIL DUSTER—It's fun... versatile... and tough!



It's what you expected of a Chrysler-engineered on-or-off road vehicle. The stability and precise control of constant four-wheel drive makes you completely at home on the way to the supermarket or a remote fishing camp.

What's more, your Trail Duster provides the kind of comfort you'll learn to appreciate when the going gets rough. Plenty of room for five, or as much as 1800 pounds of cargo. You'll find all the details in our special '75 Trail Duster Catalog.

See and drive the '75 Trail Duster, or the more deluxe Trail Duster Sport. It's always ready!

## We take extra care to make sure your Duster or Valiant takes extra care of you.

Thousands of people buy cars for what they see. Color, style, interior fabrics. Things with immediate appeal. Of course, we build our Dusters and Valiants so that you'll buy them for what you see. Also for what you *feel*. We take extra special pains to build cars that are as durable as they are excitingly and impressively styled.

That philosophy has guided us ever since the name Chrysler came into existence. And it has resulted in the kind of design innovation that creates the incomparable value represented by the 1975 Valiant and Duster automobiles.

### That pioneering spirit

There are a number of vital differences between Chrysler Corporation built cars and their competitors. Unibody is a prime example . . . in which all panels in the main body structure are fabricated with more than 4000 solid welds. The result is a single, sturdy unit that provides a high degree of strength and durability.

We protect Unibody all the while it's protecting you by giving it a thorough dip-and-spray process that fights rust and corrosion . . . kind of a deep-down metal therapy that happens *before* we apply one of our long-lasting gleaming acrylic enamel finishes. In all, there are seven steps in this outstanding process. Unibody construction, we might add, has been around since

1958 . . . and has been used for Valiant since 1960. As you might expect, Unibody has undergone constant refinement during that time.

Another example: torsion-bar suspension. It's a system that uses bars that twist to absorb shocks, rather than coils that compress. Used in combination with computer selected rear leaf springs, it's a suspension that provides a confident feel in the corners and adds to the impression that our '75 Dusters and Valiants are real drivers' cars.

Years ago, Chrysler engineers pioneered with the first production disc brakes in North America. Experience like that has led them to design slotted type linings for the disc brakes you find available on the '75.

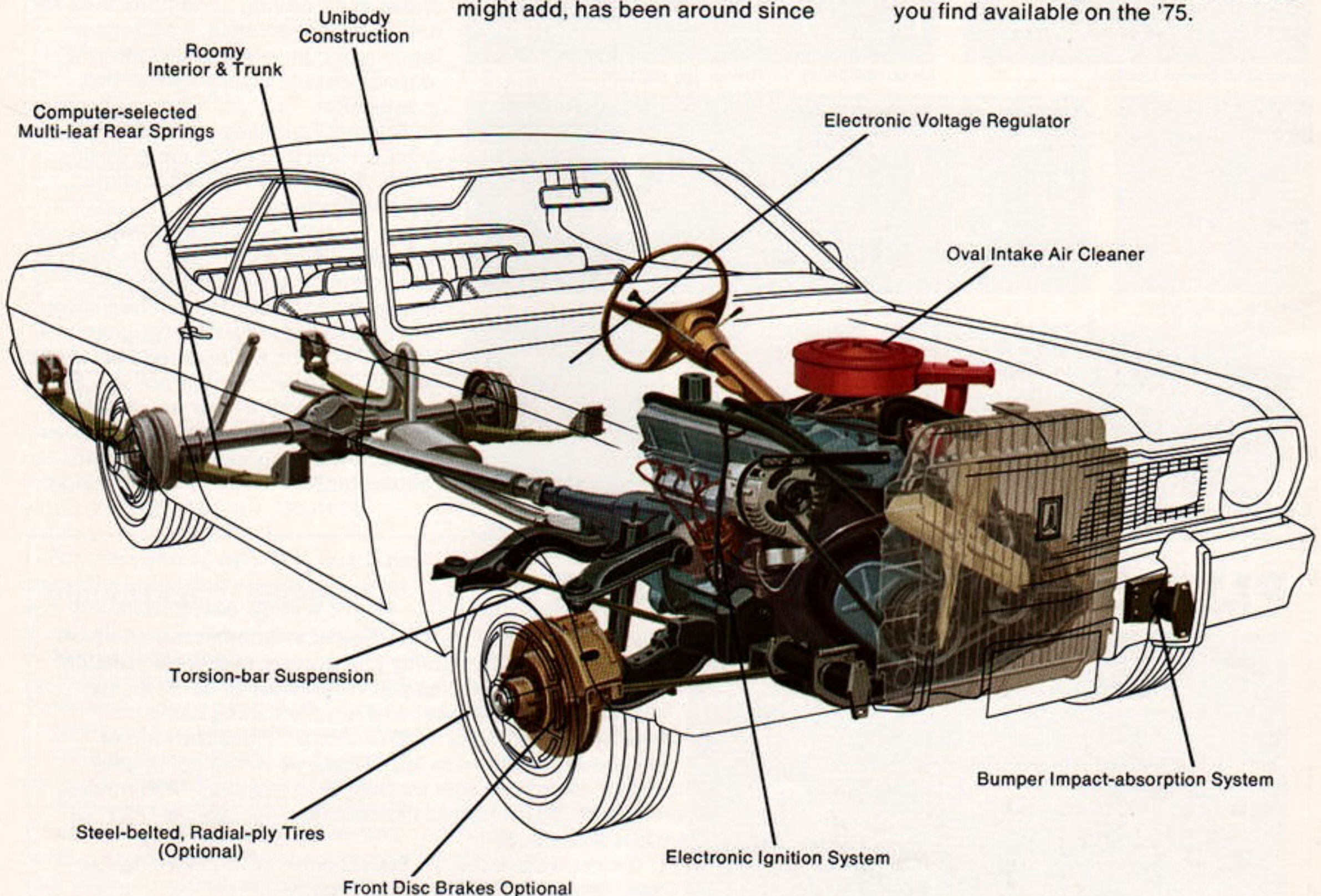

### The electronic age is here

The Electronic Ignition System you find on Duster and Valiant is one you won't find on some cars costing much, much more. The system needs no points or condensers . . . and therefore saves you the cost of normal tune-ups. In addition, the system provides up to 35% more voltage than conventional systems—something you'll appreciate on sub-zero or wet mornings.

An electronic choke assist fits into the current need for fuel economy, too. This choke shortens the period of choke operation during cold starts. And you achieve other savings through the electronic voltage regulator which helps prolong battery life.

### Building a safer car

Safety considerations need not cancel out stylish good looks. We prove it with our smart-looking Dusters and Valiants. What you do get, though, are designs that promote safe driving through sound construction, brakes,

and handling. And all owner protective devices: seat belts and restraints, impact-resistant interiors, impact-absorbing bumpers, and many others meet or exceed the most stringent of government regulations.

**You don't have to fit our cars.**

**They fit you.**

We don't see any point in making cars that make people uncomfortable. That's why our Duster and Valiant offer plenty of room for you and your passengers. That's also why we give you the option to select the kind of car and equipment (like the many make-sense features detailed on pages 12 and 13) that suits *your* needs—not somebody else's.

So, make sure you take a very thorough look at the 1975 Duster or Valiant. Outside. Inside. Underneath. Wherever you look, you find quality that rewards you every moment you own one of the new small cars from Plymouth.

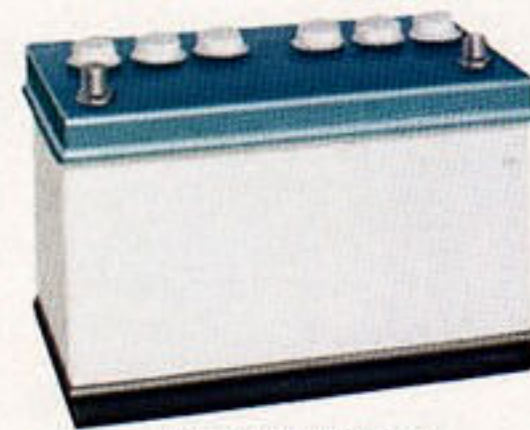

Long-Life Battery

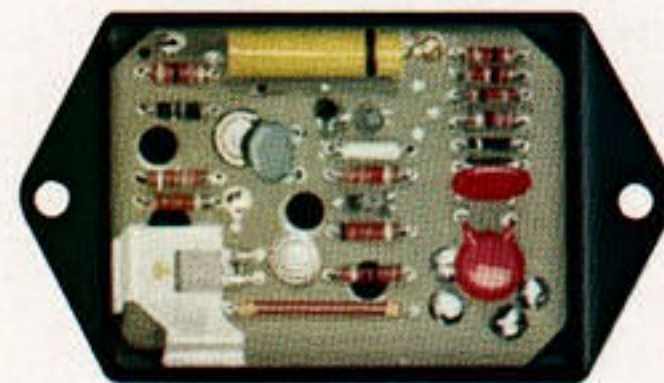

Electronic Ignition System

## 1975 DUSTER/VALIANT DIMENSIONS

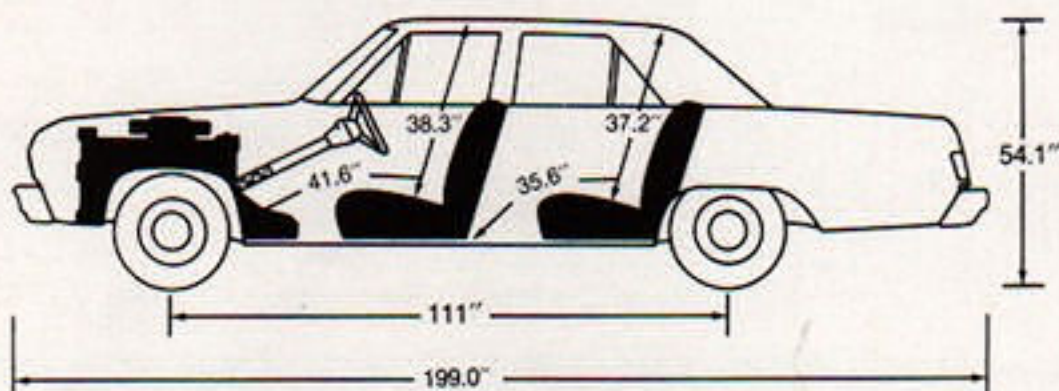

Plymouth Valiant  
4-Door Sedan

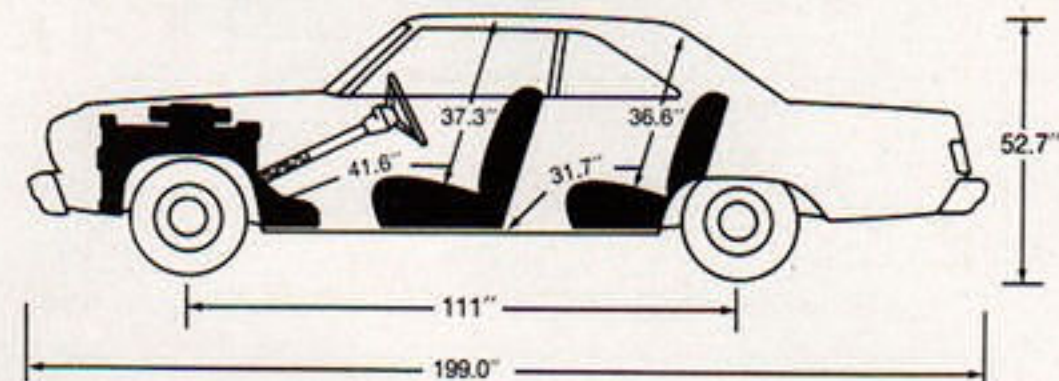
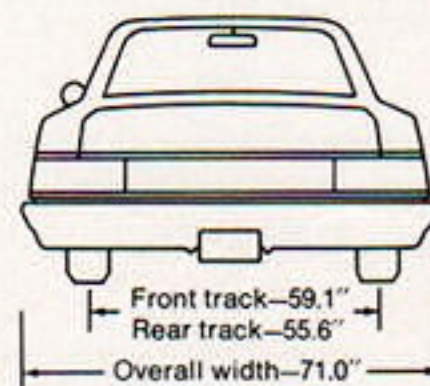

Plymouth Scamp  
2-Door Hardtop

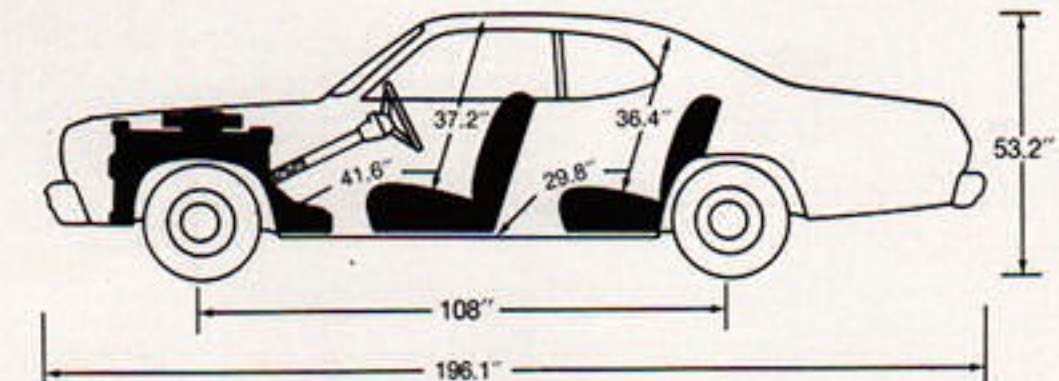
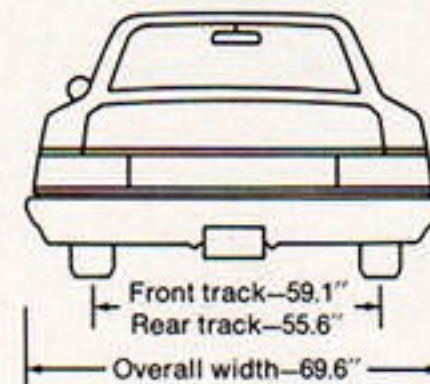

Plymouth Duster  
2-Door Coupe

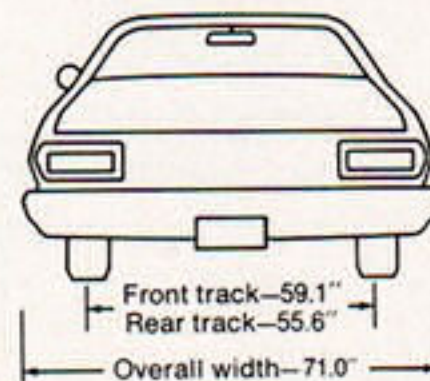

# 1975 STANDARD FEATURES

## Duster, Valiant & Scamp Standard Features

Swing-out rear quarter window (Duster only) • Vent window (Valiant Sedan) • Hubcaps (set of four) • Front and rear bumper guards • Fuel gauge • Temperature gauge • Ammeter gauge • Color-keyed armrests • Soft coat hooks • Concealed spare tire • Two-door hardtop model (available Scamp only) • Door hold-open checks • Dome lamp switch (both front doors) • Keyless door locking • 225 CID Six or 318 CID V-8 engine • 3-speed manual transmission • Torsion-bar suspension • Electronic Ignition System • Electronic voltage regulator • Electric assist choke • Front disc brakes with V-8 engine • Cleaner air system.

## Duster 360

(All of the above Duster features plus

*these additions and changes.*) Unique body side tape stripes • Roof drip rail molding • E70 bias-belted tires • Cigarette lighter • 360 CID V-8 engine • Automatic transmission • Heavy-duty suspension • 5½ x 14" wheels • Heavy-duty shock absorbers • 8¼" axle • Dual exhaust.

## Standard Safety Features

Back-up lights • Side marker lights and reflectors • Turn signal with lane-change feature • Windshield wipers—2-speed, electric • Windshield washers • Left outside rearview mirror • Passenger restraint system with starter interlock • Energy-absorbing steering column • Roof intrusion protection • Flame retardant interior materials • Anti-theft ignition and steering column lock with ignition warning buzzer • Energy-absorbing front seat-

back and armrests • Manual inside door lock (levers have non-override lock feature, except driver's door) • Interlocking door latches • Flush-type inside, door-release levers • Cushioned sun visors • Dual braking system with warning light • Hazard warning lights • Locking latch on all folding front seat-backs • Padded instrument panel • Bumper impact-absorption system, front and rear • Supplementary throttle return spring • Side door beams.

All product illustrations and specifications are based on authorized information. Although descriptions are believed correct at publication approval, accuracy cannot be guaranteed. Some of the equipment shown on product illustrations is optional, at extra cost. Chrysler Motors Corporation reserves the right to make changes from time to time, without notice or obligation in prices, specifications, colors and materials, and to change or discontinue models.

## DUSTER/VALIANT EXTERIOR COLORS



Powder Blue



Lucerne Blue Metallic



Deep Sherwood Metallic



Frosty Green Metallic



Yellow Blaze



Sahara Beige



Golden Fawn



Sienna Metallic



Cinnamon Metallic



Rallye Red



Vintage Red Metallic



Inca Gold Metallic



Spanish Gold Metallic



Spinnaker White



Silver Cloud Metallic

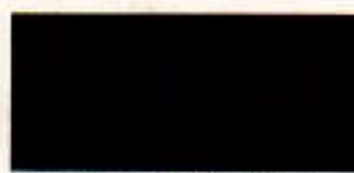

Formal Black

**NOTE:** Due to occasional printing irregularities, the above colors may vary slightly from actual hues. See your Plymouth Dealer for accurate color chips.

# Plymouth



CHRYSLER  
MOTORS CORPORATION

