

# F-650/F-750 SUPER DUTY® FORD LCF

# 2009



E-Series



F-350/F-450/F-550 Super Duty®



F-650/F-750 Super Duty



Ford LCF

## EXTENDED SERVICE PLAN FINANCIAL SERVICES

The Ford Extended Service Plan (ESP) gives you "Peace-of-Mind" protection designed to cover key vehicle components and help protect you from the cost of unexpected repairs. Ask your Dealer for a Ford ESP, the only service contract backed exclusively by Ford Motor Company of Canada, Limited, and honoured at all Ford and Ford Lincoln Dealerships across North America. Certain limitations and exclusions apply. See your Ford Medium Truck Dealer for details.



### Our commitment to you... Peace-of-Mind Protection

- Basic Coverage: 3 years/60,000 km
- Powertrain Warranty: 5 years/100,000 km
- Corrosion Warranty: 5 years/unlimited distance
- Roadside Assistance: 5 years/100,000 km

Certain conditions apply. For more information on these warranties and coverages, ask your local Ford of Canada Dealer or visit [ford.ca](http://ford.ca).

For more information on  
Ford of Canada products and services,  
please visit our website:



For prompt, courteous answers  
to your questions:

Ford Customer Relationship Centre  
1-800-565-3673  
Ford Credit Customer Service Centre  
1-877-636-7346

Competitive comparisons are based on 2008 competitive models, publicly available information and Ford data at the time of printing. Some features discussed may be optional. Vehicles shown may contain optional and aftermarket upfit equipment. Features shown may be offered only in combination with other options or subject to additional ordering requirements or limitations. Dimensions shown may vary due to optional features and/or production variability. Following publication of this catalogue, certain changes in standard equipment, options and the like, or product delays may have occurred which would not be included in these pages. Your Ford of Canada Medium Truck Dealer is your best source for up-to-date information. Ford Motor Company of Canada, Limited, reserves the right to change product specifications at any time without incurring obligations. Colours may not be exactly as illustrated due to restrictions of the printing process. Please see your sales consultant for specific colour and model availability.

Body manufacturers are responsible for compliance certification of the completed vehicle. The Ford New Vehicle Limited Warranty and any government certification made by Ford shall cover only the vehicle as manufactured by Ford and shall not extend to any modification or change of or to the vehicle by the Ford Authorized Pool Account or upfitter.



# ALL BUSINESS, all the time.

**BUSINESS IS A 24/7 COMMITMENT.** Nobody understands that better than Ford of Canada Commercial Trucks. We're here to provide you with dependable, reliable equipment to get the job done on time, every time. With the full lineup we offer, it's easy to find the right trucks to meet the demands of your business. And from the compact Ranger to the heavy-duty F-750, they're Built Ford Tough® to keep your business rolling. That means less downtime and more productivity for you and your bottom line.



## NEW FOR 2009

F-750 CAN SPEC CLASS 8 CAPABLE WITH  
A GVWR UP TO 16,783 KG (37,000 LBS.)

EATON'S FULLER® ULTRASHIFT® 6-SPEED  
FULLY AUTOMATED OVERDRIVE TRANSMISSION  
(AVAILABLE)

STANDARD WABCO® HPB BRAKING SYSTEM  
WITH MERITOR® QUADRAULIC™ CALIPERS

AVAILABLE OVERHEAD GAUGE CLUSTER  
WITH OIL TEMP AND HOUR METRE

XLT STANDARD PASSENGER SEAT WITH  
INTEGRAL HEAD RESTRAINT, 2-MAN FORWARD  
DUMP FEATURE AND IMPROVED BOLSTERS

160-AMP ALTERNATOR AVAILABLE



# F-650 XLT SUPER DUTY

# POWERFUL solutions.

TO KEEP UP WITH THE DEMANDS OF YOUR BUSINESS, the Ford F-650/F-750 Super Duty® lineup is on a continuous improvement program. It's resulted in an available clean CA (cab-to-axle) length, both across the top and down the sides, for easy upfitting. We're always looking for ways to enhance strength and long-term durability. And our vast array of options includes frame offerings, axle and suspension ratings, and exhaust system and fuel tank combinations that serve a huge range of businesses and vocations. Check out the Ford F-650/F-750 Super Duty line — you won't be disappointed.

## EATON'S FULLER® ULTRASHIFT®

A new option on 2009 F-650/F-750, the Fuller UltraShift fully automated 6-speed is feature-packed. Up to 804,672 km (500,000-mile) service interval helps reduce operating costs.<sup>2</sup> Automatic operation lessens driver fatigue. Hill Assist minimizes rolling when the truck is stopped on a grade. A standard 6-bolt PTO opening offers easy access to accessory power. These features and more make UltraShift a terrific value in a medium-duty transmission.

## ALLISON®-TAILORED VOCATIONAL TRANSMISSIONS

When your business demands the ease of an automatic, look to F-650/F-750 Super Duty's full line of high-tech, tailored, vocational transmissions.

<sup>2</sup>Under normal driving conditions.

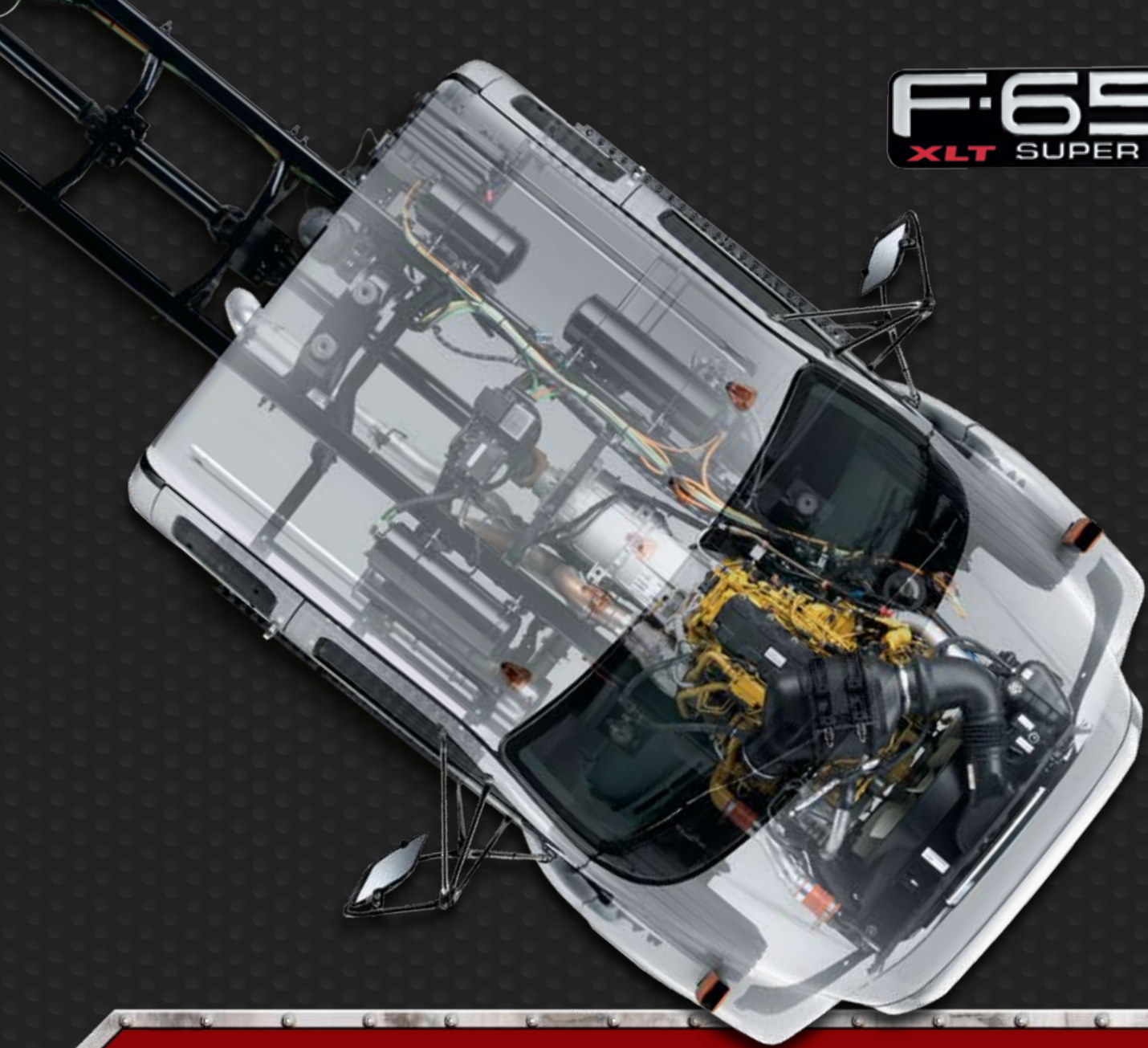

## Fuel tank selection

Model	Fuel Tank Capacity (litres)										
	330-mm (13-in.) Tank (shallow)					406-mm (16-in.) Tank (deep)					
F-650 Pro Loader*	170	246	95/170	170/170	246/170	246/246	—	—	—	—	—
F-650 <sup>1</sup>	170	246	95/170	170/170	246/170	246/246	189	246	303	189/189	246/246
F-750	170	246	95/170	170/170	246/170	246/246	189	246	303	189/189	246/246

31 different fuel tank capacity/location combinations are available. See your dealer for details.

\*Badged as Pro Loader when equipped with 19.5-in. wheels.

## Big-name power, big-time capability



### CUMMINS® ISB

ENGINE TYPE	Turbo Diesel
DISPLACEMENT	6.7 Litres
MAXIMUM RATED HORSEPOWER	325 @ 2600 rpm
MAXIMUM PEAK TORQUE	750 lb.-ft. @ 1800 rpm



### CATERPILLAR® C7

ENGINE TYPE	Turbo Diesel
DISPLACEMENT	7.2 Litres
MAXIMUM RATED HORSEPOWER	300 @ 2200 rpm
MAXIMUM PEAK TORQUE	860 lb.-ft. @ 1440 rpm

## Transmissions

Transmission Availability	Horsepower Ratings	
	Caterpillar	Cummins
Allison Automatic		
Allison 2200 5-Speed	210/210H/230/230M	200/220/240/240H/260/300
Allison 2500 5-Speed	210/210H/230/230M	200/220/240/240H/260/300
Allison 3000 5-Speed	210H/230M/230H/250/250H/275/300	240H/260/280/300/325
Allison 3000 6-Speed	210H/230M/230H/250/250H/275/300	240H/260/280/300/325
Allison 3200 5-Speed	230H/250/250H/275/300	240H/260/280/300/325
Allison 3200 6-Speed	230H/250/250H/275/300	240H/260/280/300/325
Allison 3500 5-Speed	210H/230M/230H/250/250H/275/300	240H/260/280/300/325
Allison 3500 6-Speed	210H/230M/230H/250/250H/275/300	240H/260/280/300/325
Fuller Manual		
Fuller FS-5205A 5-Speed	210	200/220
Fuller FS-5406A 6-Speed	210/230	200/220/240
Fuller FS-6406A 6-Speed	210/210H/230/230M/230H/250	220/240/240H/260/280/300
Fuller FSO-6406A 6-Speed	210/210H/230/230M/230H/250	220/240/240H/260/280/300
Fuller FSO-8406A 6-Speed	250H/275/300	280/300/325
Fuller FO-5406B <sup>3</sup> 6-Speed	210/210H/230/230M	200/220/240/240H/260/300
Fuller FO-6406B <sup>3</sup> 6-Speed	210/210H/230/230M/230H/250	220/240/240H/260/280/300
Spicer® Manual		
Spicer ES56-7B 7-Speed	210/230	200/220/240
Spicer ESO66-7B 7-Speed	210/210H/230/230M/230H/250	220/240/240H/260/280/300

M = Mid-torque engine. H = High-torque engine. <sup>3</sup>Governed speed.

# 2009 FORD F-650/F-750 SUPER DUTY®

## HEAVY-DUTY FEATURES FOR SUPER DUTY WORKLOADS

F-750 CAN SPEC CLASS 8 CAPABLE WITH A GVWR  
UP TO 16,783 KG (37,000 LBS.)

CUMMINS® ISB AND CATERPILLAR® C7  
TURBO DIESELS WITH 17 HP/TORQUE RATINGS

HIGH-HORSEPOWER/MEDIUM-TORQUE CUMMINS  
AVAILABLE WITH STANDARD AUTOMATIC TRANSMISSION

EXHAUST AFTERTREATMENT

CLEAN CA PACKAGES

LARGE AIR BRAKE COMPRESSORS

EXHAUST BRAKE OPTIONS

LARGE ENGINE COOLING SYSTEM

AIR SEAT OPTIONS

LARGE STANDARD TIRES

STANDARD 6124-KG (13,500-LB.) AND AVAILABLE 7938-KG  
(17,500-LB.) REAR AXLES ON F-650 PRO LOADER\*

6350-KG (14,000-LB.) FRONT AXLE AND PARABOLIC  
FRONT SPRINGS AVAILABLE ON F-750

STANDARD 130-AMP ALTERNATOR  
130-, 160-, 200- AND 270-AMP OPTIONAL  
ON SELECT MODELS

170- TO 549-LITRE FUEL CAPACITY OFFERINGS



# F-650/F-750 Specifications

## Frames

Model	Frame Order Code							
	533	534	53A/535	536/53F	537	53J/538	53L/539	412/410
F-650 Pro Loader	—	—	—	—	●	—	—	—
F-650 <sup>1</sup>	●	●	—	●	—	—	—	—
F-750	—	—	●	●	—	●	●	●
Depth cm (in.)	23.178 (9.125)	25.718 (10.125)	26.035 (10.250)	25.718 (10.125)	23.178 (9.125)	26.035 (10.250)	26.353 (10.375)	27.465 (10.813)
Width cm (in.)	7.777 (3.062)	7.777 (3.062)	7.854 (3.092)	9.093 (3.586)	7.777 (3.062)	9.169 (3.610)	9.411 (3.705)	9.886 (3.892)
Thickness cm (in.)	0.792 (0.312)	0.792 (0.312)	0.953 (0.375)	0.792 (0.312)	0.792 (0.312)	0.953 (0.375)	1.113 (0.438)	0.792 (0.312)
Yield strength (psi)	80,000	50,000	80,000	120,000	80,000	120,000	120,000	120,000
Maximum section modulus (cu. in.)	11.47	13.31	15.94	14.84	11.47	17.79	21.05	29.84
Max. resisting bending moment (in.-lbs.)	917,600	665,500	1,275,200	1,780,800	917,600	2,134,800	2,526,000	3,580,800

● Available — Not available

## Axles

Model	Rear Axle Rating kg (lbs.)														
	Front Axle Rating kg (lbs.)					Single Speed					Two Speed				
	3856 (8500)	4356 (10,000)	5443 (12,000)	5988 (13,200)	6350 (14,000)	6124 (13,500)	7031 (15,500)	7938 (17,500)	8618 (19,000)	9526 (21,000)	10,433 (23,000)	7938 (17,500)	8618 (19,000)	9526 (21,000)	10,433 (23,000)
F-650 Pro Loader	●	—	—	—	—	●	○	○	—	—	—	○	—	—	—
F-650 <sup>1</sup>	●	○	—	—	—	—	—	●	○	—	—	○	○	—	—
F-750	—	●	○	○	○	—	—	—	—	●	○	—	—	○	○

● Standard ○ Optional — Not available

## Suspensions

Model	Front Spring Rating kg (lbs.)					Rear Multi-Leaf Spring Rating kg (lbs.)						Rear Air Suspension Rating kg (lbs.)				
	3856 (8500)	4356 (10,000)	5443 (12,000)	5988 (13,200)	6350 (14,000)	7031 (15,500)	7938 (17,500)	8392 (18,500)	9072 (20,000)	10,660 (23,500)	14,062 (31,000)	5443 (12,000)	7031 (15,500)	8392 (18,500)	9072 (20,000)	10,433 (23,000)
F-650 Pro Loader	●	—	—	—	—	—	●	—	—	—	—	○	○	○	—	—
F-650 <sup>1</sup>	●	○	—	—	—	○	—	●	○	—	—	—	—	○	○	—
F-750	—	●	○	○	○	—	—	—	—	●	○	—	—	—	○	○

● Standard ○ Optional — Not available

## Engines

F-650 Pro Loader	
F-650 <sup>1</sup>	
F-750	
<b>Caterpillar C7</b>	
● ● ●	210 hp/520 lb.-ft. of torque
● ● ●	210 hp/620 lb.-ft. of torque
● ● ●	230 hp/560 lb.-ft. of torque
● ● ●	230 hp/620 lb.-ft. of torque
● ● ●	230 hp/660 lb.-ft. of torque
● ● ●	250 hp/660 lb.-ft. of torque
● ● ●	250 hp/800 lb.-ft. of torque
● ● ●	275 hp/800 lb.-ft. of torque
● ● ●	300 hp/860 lb.-ft. of torque
<b>Cummins ISB</b>	
● ● ●	200 hp/520 lb.-ft. of torque
● ● ●	220 hp/520 lb.-ft. of torque
● ● ●	240 hp/560 lb.-ft. of torque
● ● ●	240 hp/620 lb.-ft. of torque
● ● ●	260 hp/620 lb.-ft. of torque
● ● ●	280 hp/660 lb.-ft. of torque
● ● ●	300 hp/620 lb.-ft. of torque
● ● ●	325 hp/750 lb.-ft. of torque

● Available

## Weight Ratings & Wheelbase/ Cab-to-Axle Ranges

Model	GVWR kg (lbs.)	Cab	Wheelbase/Cab-to-Axle Range cm (in.)	Options
F-650 Pro Loader	9095 – 11,794 (20,050 – 26,000)	Regular Cab	340/152 – 615/427 (134/60 – 242/168)	6
		SuperCab	394/152 – 607/366 (155/60 – 239/144)	4
		Crew Cab	432/152 – 645/366 (170/60 – 254/144)	4
F-650 <sup>1</sup>	9503 – 13,154 (20,950 – 29,000)	Regular Cab	371/183 – 660/472 (146/72 – 260/186)	13
		SuperCab	424/183 – 714/472 (167/72 – 281/186)	13
		Crew Cab	462/183 – 706/427 (182/72 – 278/168)	12
F-750	11,793 – 16,783 (25,999 – 37,000)	Regular Cab	371/183 – 714/526 (146/72 – 281/207)	15
		SuperCab	424/183 – 714/472 (167/72 – 281/186)	13
		Crew Cab	462/183 – 676/396 (182/72 – 266/156)	11

<sup>1</sup>Badged as Pro Loader when equipped with 19.5-in. wheels.

# F-650/F-750 Specifications

## Features & Options

F-650 Pro Loader*	
	F-650 <sup>1</sup>
	F-750
<b>Axle &amp; Suspension — Front</b>	
<input type="checkbox"/>	Auxiliary springs — Rubber
<input type="checkbox"/>	Axle lube — EmGard® 50W synthetic oil
<input checked="" type="checkbox"/>	Shock absorbers — Double-acting
<input checked="" type="checkbox"/>	Wheel seals — STEMCO® Guardian® with mineral oil-lubricated wheel bearings
<b>Axle &amp; Suspension — Rear</b>	
<input type="checkbox"/>	Air suspension (requires air brakes or compressor)
<input type="checkbox"/>	Air suspension dump valve
<input type="checkbox"/>	Air suspension leveling valve
<input type="checkbox"/>	Axle lube — EmGard 75W-90 synthetic oil
<input checked="" type="checkbox"/>	Multi-leaf springs — Vari-rate suspension
<input type="checkbox"/>	Shock absorbers
<input checked="" type="checkbox"/>	Wheel seals — STEMCO with mineral oil-lubricated wheel bearings
<b>Brakes &amp; Brake Equipment</b>	
<input checked="" type="checkbox"/>	ABS — Quadraulic™ 4-channel Anti-lock Brake System (ABS)
<input type="checkbox"/>	Air brake with Traction Control — Automatic
<input type="checkbox"/>	Air brake system — Straight truck use only
<input type="checkbox"/>	Air brake system — Tractor use only (Regular Cab and SuperCab only)
<input type="checkbox"/>	Air compressor (Cat® standard 13.2-CFM with F-650 Pro Loader; 16.1-CFM capacity with Caterpillar® engines)
<input type="checkbox"/>	Air compressor (Wabco® 18.7-CFM capacity with Cummins® engines)
<input type="checkbox"/>	Air dryer (Bendix® AD/IP) with heater — Mounted inside left frame rail, back of cab (not available with hydraulic brakes)
<input type="checkbox"/>	Air tank location — Under cab
<input type="checkbox"/>	Drain valve (1) — Automatic (Bendix DV-2) with heater
<input type="checkbox"/>	Hydraulic Brake System with Traction Control — Automatic
<input checked="" type="checkbox"/>	Parking brake — Bosch DSSA-type 305 mm x 76 mm (12 in. x 3 in.), rear axle-mounted
<input checked="" type="checkbox"/>	Parking brake control
<b>Trailer Connections</b>	
<input type="checkbox"/>	Trailer Air Brake Package — 4-wheel
<input type="checkbox"/>	Trailer connection socket — 7-way
<b>Fuel Tanks</b>	
<input checked="" type="checkbox"/>	Steel — Shallow (330-mm/13-in. depth)
<input type="checkbox"/>	Steel — Deep (406-mm/16-in. depth)

● Standard ● Select Availability ○ Optional — Not available

\*Badged as Pro Loader when equipped with 19.5-in. wheels.

## Wheels — F-650/F-750



Painted-White Steel (front)

Polished-Aluminum (front)

F-650 Pro Loader	
	F-650
	F-750
<b>Engine Equipment</b>	
<input checked="" type="checkbox"/>	Air cleaner — Donaldson® with restriction gauge
<input checked="" type="checkbox"/>	Engine block heater
<input type="checkbox"/>	Engine exhaust brake
<input checked="" type="checkbox"/>	Fan clutch — BorgWarner
<input type="checkbox"/>	Fuel tanks — Dual with transfer pump
<input checked="" type="checkbox"/>	Fuel/water separator — Fleetguard®, electric-type, heated
<input type="checkbox"/>	Fuel/water separator — Racor®, electric, heated (Caterpillar)
<input checked="" type="checkbox"/>	Radiator — 4626-cm (717 sq.-in.) cross-flow, aluminum; 108-mm (4.25-in.) core
<input checked="" type="checkbox"/>	Starting motor — 12-volt
<b>Drivelines &amp; Clutches</b>	
<input type="checkbox"/>	Clutch — Fuller® 356-mm (14-in.), single-plate, adjustment-free
<input type="checkbox"/>	Clutch — Fuller 356-mm (14-in.), 2-plate, adjustment-free
<input checked="" type="checkbox"/>	Driveline — Spicer® SPL100
<input type="checkbox"/>	Driveline — Spicer SPL140
<input type="checkbox"/>	Synthetic transmission oil — EmGard 50W for manual transmissions
<input type="checkbox"/>	Synthetic transmission oil — Castrol® TranSynd™ for Allison® automatic transmissions
<b>Exhaust</b>	
<input checked="" type="checkbox"/>	Single, horizontal aftertreatment device, frame-mounted on back of cab, under right rail; horizontal tailpipe with right-side outlet and heat diffuser (Cummins engine only)
<input checked="" type="checkbox"/>	Single, horizontal aftertreatment device, frame-mounted under cab, outside of right rail; horizontal tailpipe with left-side outlet and heat diffuser
<input type="checkbox"/>	Single, horizontal aftertreatment device, frame-mounted under cab, outside of right rail; horizontal tailpipe with right-side outlet and heat diffuser
<input type="checkbox"/>	Single, horizontal aftertreatment device, frame-mounted under cab, outside of right rail; vertical non-bright tailpipe with right-side outlet
<input type="checkbox"/>	Rain cap, non-bright-finish — For vertical exhaust (Caterpillar only)
<b>Electrical</b>	
<input checked="" type="checkbox"/>	Alternator — 130-amp Leece-Neville
<input type="checkbox"/>	Alternators — 130-, 160-, 200- or 270-amp
<input type="checkbox"/>	Backup alarm — Electric, 102 decibels
<input checked="" type="checkbox"/>	Batteries — 625 CCA (2 for a total of 1250 CCA)
<input type="checkbox"/>	Batteries — 900 CCA (2 for a total of 1800 CCA)
<input type="checkbox"/>	Batteries — 625 CCA (3 for a total of 1875 CCA)
<input type="checkbox"/>	Batteries — 900 CCA (3 for a total of 2700 CCA)
<input type="checkbox"/>	Battery — Temporarily mounted (dual 625 CCA battery only)
<input checked="" type="checkbox"/>	Battery box — Aft of fuel tank
<input checked="" type="checkbox"/>	Body-builder wiring — At back of cab at frame
<input type="checkbox"/>	Body-builder special beverage wiring harness
<input type="checkbox"/>	Body-builder wiring — To end of frame
<input checked="" type="checkbox"/>	Daytime running lamps
<input checked="" type="checkbox"/>	Electrical system — 12-volt
<input checked="" type="checkbox"/>	Emergency flashers
<input checked="" type="checkbox"/>	Fuses — SAE blade-type
<input checked="" type="checkbox"/>	Headlamps — Rectangular halogen sealed-beam (includes front-side marker lamps with reflectors)
<input type="checkbox"/>	Jump-start stud — Remote-mounted
<input type="checkbox"/>	Stop, turn, tail and backup lamps
<input checked="" type="checkbox"/>	Tail lamps — 2 with integral stop, turn signal, backup and licence plate
<input type="checkbox"/>	Tail lamps — Delete
<input type="checkbox"/>	Turn-signal lamps — Fender-mounted, front- and rear-facing

## Features & Options Continued

F-650 Pro Loader	
	F-650
	F-750
<b>Cab Equipment</b>	
<input checked="" type="checkbox"/>	XL Trim Package — Includes moulded-cloth headliner; LH/RH coat hooks; hi-back driver seat with 2-person passenger seat; G-grain vinyl seat trim; 2nd-row bench (SuperCab and Crew Cab); cloth sun visors with passenger-side mirror; exterior body-colour-painted back panel; door-trim panels with reflector; manual air conditioning; chrome headlamp bezels; chrome grille; chrome front bumper (XL only)
<input checked="" type="checkbox"/>	XLT Trim Package — Includes moulded-cloth headliner; LH/RH coat hooks; hi-back driver and passenger seats with integral head restraints, folding/reclining backs (intermediate folding centre back creates armrest with cupholder); Mortar cloth seat trim with Marta cloth insert; 2nd-row bench (SuperCab and Crew Cab); cloth sun visors with passenger-side mirror; Rigitex back-panel trim; moulded door-trim panels with lower map pocket and carpet on face; manual air conditioning; Power Equipment Group including power windows and power door locks; AM/FM stereo with single-CD player; front tow hooks; chrome headlamp bezels; chrome grille; chrome front bumper (XLT only)
<b>Cab Equipment — Exterior</b>	
<input checked="" type="checkbox"/>	Assist handles — B-pillar with Regular Cab
<input checked="" type="checkbox"/>	Assist handles — Rear doors with SuperCab
<input checked="" type="checkbox"/>	Assist handles — Rear-passenger; C-pillars with Crew Cab
<input type="checkbox"/>	Frame extension — Front bolt-on type, 508-mm (20-in.) without crossmember (requires fixed grille, swept back front bumper or front bumper delete)
<input checked="" type="checkbox"/>	Front bumper — Full-width, chrome-steel
<input type="checkbox"/>	Front bumper — Full-width, painted-steel, Dark Shadow Grey-colour
<input type="checkbox"/>	Front bumper — Swept back, Dark Shadow Grey (requires frame extension)
<input type="checkbox"/>	Front bumper — Delete
<input checked="" type="checkbox"/>	Front-end tilting fiberglass hood and fenders assembly — Frame-mounted with torsion-bar assist (includes integral noise shield, inner splash shields and mud flaps)
<input checked="" type="checkbox"/>	Glass — Laminated windshield; solar-tinted all around
<input type="checkbox"/>	Glass — Privacy glass (tinted rear sliding and rear cab windows for SuperCab and Crew Cab)
<input checked="" type="checkbox"/>	Grille — Chrome (includes chrome headlamp bezels)
<input type="checkbox"/>	Grille — Dark Shadow Grey
<input type="checkbox"/>	Grille — Fixed Dark Shadow Grey
<input checked="" type="checkbox"/>	Horn — Dual electric
<input type="checkbox"/>	Horn — Air, black, single trumpet
<input checked="" type="checkbox"/>	Lamps — Roof marker/clearance (5)
<input type="checkbox"/>	Licence plate holder, front — Includes upper and lower mounting-plate hardware
<input checked="" type="checkbox"/>	Mirrors — Dual rectangular, 191 mm x 419 mm (7.5 in. x 16.5 in.) stainless steel, West Coast-style; 2591-mm (102-in.) wide spacing
<input type="checkbox"/>	Mirrors — Dual rectangular, 191 mm x 419 mm (7.5 in. x 16.5 in.) stainless steel; West Coast-style; 2591-mm (102-in.) wide spacing with auxiliary convex mirrors; 203-mm (8-in.) diameter; mounted below primary mirrors
<input type="checkbox"/>	Mirrors — Dual stainless steel with heated and lighted heads; rectangular; 191 mm x 419 mm (7.5 in. x 16.5 in.) West Coast-style; 2591-mm (102-in.) wide spacing
<input type="checkbox"/>	Mirrors — Dual stainless steel with heated and lighted heads; rectangular; 191 mm x 419 mm (7.5 in. x 16.5 in.) West Coast-style; 2591-mm (102-in.) wide spacing with auxiliary convex mirrors; 203-mm (8-in.) diameter; mounted below primary mirrors
<input type="checkbox"/>	Mirrors — Sail-type, power, 203 mm x 229 mm (8 in. x 9 in.) with 203 mm x 76 mm (8 in. x 3 in.) integral convex mirrors; telescoping breakaway-type brackets (XLT only)
<input type="checkbox"/>	Mud flap holders — Spring-loaded, painted-black, with red and white reflective tape
<input type="checkbox"/>	Mud flaps, rear — Black rubber, anti-sail
<input type="checkbox"/>	Power Equipment Group Delete — 2 power windows with power door locks (4 with Crew Cab) (XLT only)
<input type="checkbox"/>	Tow hooks, front — Frame-mounted (2) (standard on XLT)
<input checked="" type="checkbox"/>	Window, rear — Fixed
<input checked="" type="checkbox"/>	Windshield wipers — 2-speed intermittent with washers

F-650 Pro Loader	
	F-650
	F-750
<b>Cab Equipment — Interior</b>	
<input checked="" type="checkbox"/>	Air conditioning — Manual, includes integral heater and defroster
<input type="checkbox"/>	Air conditioning — Delete (XL only)
<input checked="" type="checkbox"/>	Air registers — LH, LHC, RHC with positive shutoff
<input checked="" type="checkbox"/>	AM/FM stereo with clock and 2 speakers (XL only)
<input type="checkbox"/>	AM/FM stereo with single-CD player, clock and 4 speakers (standard on XLT)
<input type="checkbox"/>	AM/FM stereo with 6-disc in-dash CD changer, clock and 4 speakers
<input type="checkbox"/>	Radio — Delete
<input checked="" type="checkbox"/>	Ashtray — Instrument panel
<input checked="" type="checkbox"/>	Assist handle — Front-passenger; B-pillar
<input checked="" type="checkbox"/>	Auxiliary power point — Instrument panel
<input checked="" type="checkbox"/>	Back panel cover — Rigitex (XLT Regular Cab only)
<input checked="" type="checkbox"/>	Cigar lighter — Instrument panel
<input checked="" type="checkbox"/>	Coat hooks — LH/RH, colour-keyed
<input type="checkbox"/>	Console — Floor-mounted between front seats
<input checked="" type="checkbox"/>	Cruise control — Instrument panel-mounted
<input checked="" type="checkbox"/>	Cupholders — Instrument panel
<input checked="" type="checkbox"/>	Demisters — LH/RH side-window
<input checked="" type="checkbox"/>	Dome light — Centre (LH/RH, door-activated, I/P switch-operated with delay)
<input checked="" type="checkbox"/>	Floor covering — Black, full, Maslite-type
<input checked="" type="checkbox"/>	Gauge cluster — Includes electronic speedometer (km/h, mph), trip odometer, voltmeter, oil pressure, coolant temperature, fuel gauge, tachometer and indicator lights
<input type="checkbox"/>	Gauge cluster (overhead non-Eaton automatic transmission) — Includes transmission oil temperature and hour metre
<input checked="" type="checkbox"/>	Glove compartment — Instrument panel, RH
<input checked="" type="checkbox"/>	Grab handle — Front-passenger, A-pillar-mounted
<input checked="" type="checkbox"/>	Headliner — Colour-coordinated, moulded-cloth
<input checked="" type="checkbox"/>	Instrument panel — Colour-keyed with colour-coordinated accents
<input type="checkbox"/>	Leather Trim Package — Includes leather-trimmed front captain's chairs, front floor mats, power windows and locks, carpeting, dual cloth sun visors, and centre floor console between front seats (XLT only)
<input type="checkbox"/>	Passenger seat — Delete
<input type="checkbox"/>	Rear seat — Delete (SuperCab or Crew Cab)
<input checked="" type="checkbox"/>	Safety belts <sup>2</sup> — Belt-Minder® system (chime and flashing warning light on instrument panel if driver safety belt isn't buckled)
<input checked="" type="checkbox"/>	Safety belts — Colour-keyed; all positions include fixed D-rings (Regular Cab)
<input checked="" type="checkbox"/>	Safety belts — Colour-keyed, front-seat; adjustable D-rings (SuperCab or Crew Cab)
<input checked="" type="checkbox"/>	Scuff plates — Colour-keyed
<input checked="" type="checkbox"/>	Steering column — Tilt
<input checked="" type="checkbox"/>	Steering wheel — 2-spoke, black vinyl (394-mm/15.5-in. diameter with 3856-kg/8500-lb. front axle; 445-mm/17.5-in. diameter with 4536-kg/10,000-lb. front axle)
<input type="checkbox"/>	Steering wheel — 2-spoke, black leather-wrapped (394-mm/15.5-in. diameter only) (XLT only)
<input checked="" type="checkbox"/>	Sun visors — Driver and passenger, cloth
<input checked="" type="checkbox"/>	Turn-signal switch — Multifunction, self-canceling
<input type="checkbox"/>	Turn-signal switch — Non-self-canceling (tractor use only)
<input checked="" type="checkbox"/>	Utility tray — Floor-mounted behind seat (XLT Regular or Crew Cab only)
<input checked="" type="checkbox"/>	Utility tray — Hung on back panel (XLT Regular Cab only)

<sup>2</sup>Always wear your safety belt.

NOTE: See page 13 for F-650/F-750 exterior colours.

Ford LCF is the only vehicle in the segment<sup>1</sup> to use the strength of HUCK BOLTS™ to join all non-serviceable frame components. This proven frame-fastening technology permanently locks frame components in place, while delivering rigidity and longevity superior to that of rivet-fastening systems used by other truck makers.



EXCLUSIVE HUCK BOLT CONSTRUCTION (ACTUAL SIZE)

# LIGHT heavyweight.



WITH CLASS-LEADING<sup>1</sup> MANOEUVRABILITY AND OUTSTANDING CAPABILITY, Ford LCF gets your big cargo where you need it to go. Its 4.5L Power Stroke® V6 Turbo Diesel delivers heavy-duty horsepower and torque. Innovative design provides a best-in-class turning radius. And of course, it's Built Ford Tough,<sup>®</sup> with the strongest standard frame (RBM)! Conquer tight city streets with agility and efficiency. And do it in style, with a selection of 9 vibrant exterior colours. When performance is all that matters, Ford LCF really shines.



CHASSIS	WHEELBASE (WB) mm (in.)	AFT-OF-AXLE (AF) mm (in.)	CAB-TO-AXLE (CA) mm (in.)	OVERALL LENGTH (OAL) mm (in.)	
CLASS 4 MODEL: L45	2921 (115)	1207 (47.5)	2184 (86)	5199 (204.7)	
	2921 (115)	1600 (63.0)	2184 (86)	5593 (220.2)	
	3480 (137)	1207 (47.5)	2743 (108)	5809 (228.7)	
	3480 (137)	1600 (63.0)	2743 (108)	6203 (244.2)	
	3785 (149)	1207 (47.5)	3048 (120)	6114 (240.7)	
RBM: 461,000 in.-lbs.	3785 (149)	1905 (75.0)	3048 (120)	6812 (268.2)	
	4242 (167)	1905 (75.0)	3505 (138)	7269 (286.2)	
	CLASS 5 MODEL: L55	2921 (115)	1207 (47.5)	2184 (86)	5199 (204.7)
		2921 (115)	1600 (63.0)	2184 (86)	5593 (220.2)
		3480 (137)	1207 (47.5)	2743 (108)	5809 (228.7)
3480 (137)		1600 (63.0)	2743 (108)	6203 (244.2)	
3785 (149)		1207 (47.5)	3048 (120)	6114 (240.7)	
RBM: 461,000 in.-lbs.	3785 (149)	1905 (75.0)	3048 (120)	6812 (268.2)	
	4242 (167)	1905 (75.0)	3505 (138)	7269 (286.2)	
	4699 (185)	2438 (96.0)	3962 (156)	8260 (325.2)	

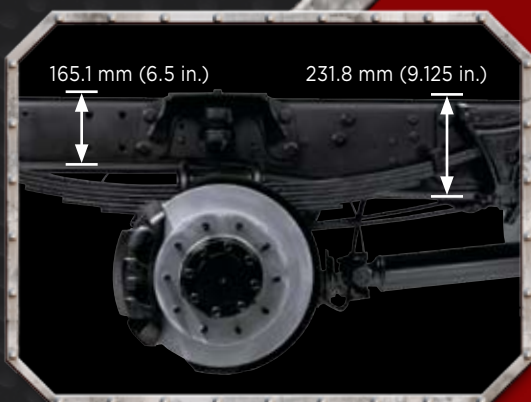

## PRACTICAL & VERSATILE

The low 762-mm (30-in.) ground-to-top-of-frame height of the Ford LCF **STANDARD KICKUP FRAME** is ideally suited to applications that require a low, flat loadfloor. An **864-MM (34-IN.) FRAME RAIL WIDTH** and several different clean CA (cab-to-axle) measurements let you choose from a vast array of compatible upfit bodies. **FUEL TANK OPTIONS** include the standard **151-LITRE TANK** mounted aft-of-axle, an available **132-LITRE SIDE TANK** mounted outside the frame rail on the left, and for maximum range, opt for **TWO 132-LITRE SIDE TANKS**. The Ford LCF also features **2 MAINTENANCE-FREE BATTERIES** conveniently mounted in a box outside the frame rails on the right.

## RUGGED DRIVELINE

Standard on every Ford LCF, the proven TorqShift® 5-speed automatic transmission features pure **ELECTRONIC SHIFT CONTROLS** for optimum responsiveness and a torque converter designed for enhanced low-speed capability. Its high-capacity pump design improves lubrication and cooling, while heavy-duty materials enhance durability. Select **TOW/HAUL MODE** when hauling a heavy load or trailer. It helps reduce gear hunting, improves power delivery, and uses engine braking to help control vehicle speed when descending hills. The available **POWER TAKEOFF (PTO)** provision (Order Code 44B) is essential for powering accessories like liftgates, skylifts, auxiliary hydraulic pumps, etc.



<sup>1</sup>Class 4 Tilt-Cab Diesels, excluding Ford joint-venture partners.

# 2009 FORD LCF



## BEST-IN-CLASS TURNING RADIUS STRONGEST STANDARD FRAME (RBM) OUTSTANDING POWER AND TORQUE

- 4.5L POWER STROKE® V6 TURBO DIESEL
  - 200 HORSEPOWER
  - 440 LB.-FT. OF TORQUE
- FORD CLEAN DIESEL TECHNOLOGY™
- 3 GVWR OFFERINGS: 6804 AND 7258 KG (15,000 AND 16,000 LBS.) (L45); 8845 KG (19,500 LBS.) (L55)
- 4-WHEEL DISC BRAKES WITH ABS
- EXCLUSIVE HUCK BOLT™ FRAME CONSTRUCTION
  - 19.5-IN. WHEELS AND TIRES
  - 9 EXTERIOR COLOUR CHOICES
  - POWER WINDOWS AND DOOR LOCKS
  - CLOTH SEAT TRIM

# Ford LCF Specifications

## Standard Equipment

### Mechanical

Engine — 4.5L Power Stroke V6 Turbo Diesel  
 Transmission — TorqShift® 5-speed automatic with Tow/Haul Mode  
 Air cleaner — Single-element with Filter Minder® indicator  
 Alternator — 12-volt, 135-amp  
 Batteries — Dual, Motorcraft® 12-volt; 1800 CCA total  
 Brakes — Front/rear disc, hydraulic split system with 3-channel Anti-lock Brake System (ABS)  
 Cruise control  
 Engine block heater  
 Shock absorbers — Front  
 Springs — Auxiliary rear; 680-kg (1500-lb.) rating  
 Stabilizer bar — Front  
 Steering — Power; Ross TAS37

### Exterior

Bumper — Front, Argent moulded-in-colour  
 Cab steps — Integrated into wheel lip  
 Clearance lamps — 5 roof-mounted  
 Daytime running lamps  
 Doors — With drop window and black handle  
 Grille — Dark Shadow Grey  
 Headlamps — Jeweled-appearance  
 Licence plate surround — Moulded into front bumper fascia  
 Mirrors — Dual sideview 152 mm x 279 mm (6 in. x 11 in.) rectangular, and 203 mm x 152 mm (8 in. x 6 in.) convex rectangular with breakaway-type brackets; 2591-mm (102-in.) wide spacing  
 Tinted glass  
 Tow hooks — 2 front  
 Wipers — Fixed and interval settings with wet-arm washer fluid delivery

### Interior

Cupholders — 2 integrated into instrument panel  
 Dome light — Door-operated or manual switch  
 Door trim — With map pockets (1 per door)  
 Floor covering — Vinyl  
 Grab handles — Driver and passenger A-pillar-mounted  
 Headliner — Colour-coordinated cloth  
 Heater — With defroster and 4-speed blower motor  
 Horn — Electric  
 Instrument panel — Colour-coordinated with 3 glove compartments, 2 storage bins, air registers, left-hand and centre ashtrays, and cigar lighter  
 Instrumentation — Tachometer, trip odometer, fuel gauge, coolant temperature gauge and indicator lights  
 Mirror — Rearview  
 Overhead storage — Full-length, 3-bin  
 Power door locks and power windows with one-touch-down driver-window feature  
 Power point — Right-side, located below instrument panel  
 Safety belts — 3-point (driver and outboard-passenger) and lap belt (centre)  
 Scuff plates — Colour-coordinated with interior trim  
 Seat — Driver tilt, high-back cloth with integral head restraint  
 Seat — Centre-passenger high-back cloth with integral head restraint and folding seatback with notebook tray and 2 cupholders  
 Seat — Outboard-passenger high-back cloth with integral head restraint and folding seatback  
 Steering column — Tilt/telescoping  
 Steering wheel — 16-in. diameter  
 Sun visors — Vinyl with driver-side strap  
 Transmission shift control — Floor-mounted with button for Tow/Haul Mode

## Features & Options

L45

L55

### Mechanical

- — Axle, front — Dana Spicer® 2722-kg (6000-lb.) I-Beam-type
- ● — Axle, front — Dana Spicer 3175-kg (7000-lb.) I-Beam-type<sup>1</sup>
- — Axle, rear — Dana Spicer 4990-kg (11,000-lb.) single-reduction
- ● — Axle, rear — Dana Spicer 6124-kg (13,500-lb.) single-reduction<sup>2</sup>
- ● — Fuel tank — 151-litre capacity steel, mounted between frame rails, aft of rear axle
- ○ — Fuel tank — 132-litre capacity steel, rectangular, mounted to left side of frame
- ○ — Fuel tanks — Dual 132-litre capacity steel (264-litre total capacity), rectangular, mounted to left and right sides of frame<sup>3</sup>
- — GVWR — 7258-kg (16,000-lbs.)
- — GVWR — 6804-kg (15,000-lbs.)
- ● — GVWR — 8845-kg (19,500-lbs.)
- ○ — Limited-slip rear differential
- ○ — PTO (Power TakeOff) provision — Opening on left side of transmission
- ○ — Shock absorbers — Rear
- — Springs, front — 2722-kg (6000-lb.) tapered leaf
- ● — Springs, front — 3175-kg (7000-lb.) tapered leaf<sup>4</sup>
- — Springs, rear — 4990-kg (11,000-lb.) single variable-rate
- ● — Springs, rear — 6124-kg (13,500-lb.) single variable-rate<sup>5</sup>
- ○ — Tires — 225/70R19.5 Goodyear G647RSS, load-range F (6)
- ○ — Tires — 225/70R19.5 Michelin XZE, load-range F (6)
- ● — Tires — 225/70R19.5 Hankook AH 11 (6)
- ○ — Tires — 225/70R19.5 Hankook DH 01, rear traction (4)
- ● — Wheels — 19.5 in. x 6 in. hub-piloted, 10-lug, painted-white steel (6)
- ○ — Wheels — 19.5 in. x 6 in. hub-piloted, 10-lug, polished-aluminum (6)

### Exterior

- ○ — Backup alarm
- ○ — Chrome Package — Includes chrome grille and front bumper, and tow hook delete
- ○ — Licence plate bracket (requires Chrome Package)
- ○ — Tail lamps delete

### Interior

- ○ — Air conditioning
- ● — AM/FM stereo with clock
- ○ — AM/FM stereo with single-CD player and clock (satellite ready)
- ○ — Power windows and door locks delete
- ○ — Radio Prep Package — Includes wiring and antenna with multiple dual-cone speakers; radio not included
- ○ — Vinyl-covered seating

● Standard ○ Optional — Not available

<sup>1</sup> Requires 3175-kg (7000-lb.) front springs.

<sup>2</sup> Requires 6124-kg (13,500-lb.) rear springs.

<sup>3</sup> Not available with 2921-mm (115-in.) wheelbase.

<sup>4</sup> Requires 3175-kg (7000-lb.) front axle.

<sup>5</sup> Requires 6124-kg (13,500-lb.) rear axle.

## Wheels – Ford LCF



Painted-White Steel (front)



Polished-Aluminum (front)

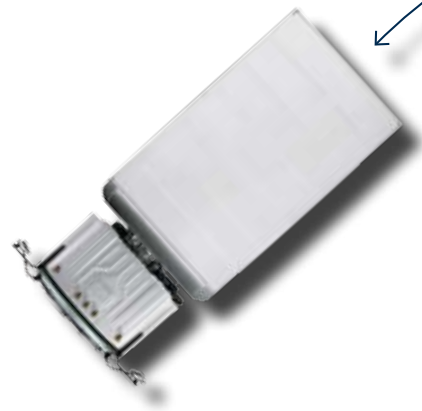

# Best-in-class Turning Radius

MODEL	WHEELBASE	CURB-TO-CURB	WALL-TO-WALL
L45/L55	2921 mm (115 in.)	5.05 m (16 ft. 7 in.)	5.66 m (18 ft. 7 in.)
	3480 mm (137 in.)	5.87 m (19 ft. 3 in.)	6.40 m (21 ft. 0 in.)
	3785 mm (149 in.)	6.30 m (20 ft. 8 in.)	6.83 m (22 ft. 5 in.)
	4242 mm (167 in.)	6.83 m (22 ft. 5 in.)	7.37 m (24 ft. 2 in.)
L55	4699 mm (185 in.)	7.47 m (24 ft. 6 in.)	8.00 m (26 ft. 3 in.)

## Dimensions

- A. Bumper-to-back-of-cab (BBC) — 1608 mm (63.3 in.)
- B. Bumper-to-front-axle (BA) — 1123 mm (44.2 in.)
- C. Frame to top of cab — 1572 mm (61.9 in.)
- D. Top of cab from ground — 2291 mm (90.2 in.)
- E. Step to ground — 457 mm (18.0 in.)
- F. Cab sill to ground — 892 mm (35.1 in.)
- G. Frame height at centre line of axle, front (unloaded) — 719 mm (28.3 in.)
- H. Frame height at centre line of axle, rear (unloaded) — 762 mm (30.0 in.)
- I. Mirror width (centre to centre) — 2921 mm (115.0 in.)
- J. Bumper width — 2106 mm (82.9 in.)
- K. Fender width — 2106 mm (82.9 in.)
- L. Overall width, front — 2215 mm (87.2 in.)  
Overall width, rear — 2377 mm (93.6 in.) (not shown)
- M. Track, front — 1864 mm (73.4 in.)  
Track, rear — 1880 mm (74.0 in.) (not shown)

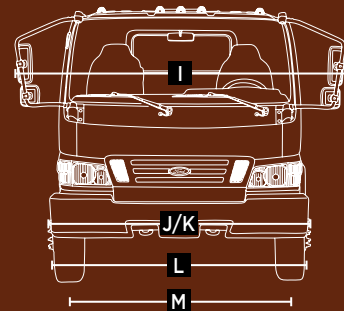
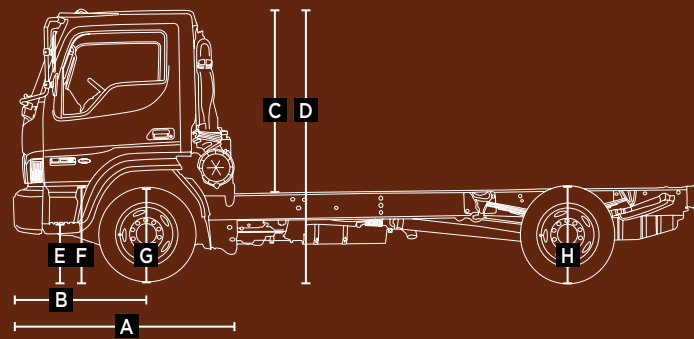

5.05 m (16 ft., 7 in.)  
Turning Radius

You'll really appreciate how easy it is to navigate the Ford LCF up to loading docks and around crowded job sites. It's all thanks to the superb manoeuvrability provided by the segment's **TIGHTEST CURB-TO-CURB** and **WALL-TO-WALL TURNING RADIUS**. The Ford LCF also features a remarkably **SHORT 1608-mm (63.3-in.) BUMPER-TO-BACK-OF-CAB (BBC)** measurement. That's the beauty of the tilt-cab design. The steering system also contributes, with innovative engineering that delivers high-efficiency turn-in. So the Ford LCF makes tight corners and fits into small spaces that can leave other trucks double-parked.

## Specifications

### Exterior Colours – F-650/F-750 and Ford LCF

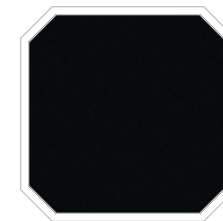

Black



Oxford White

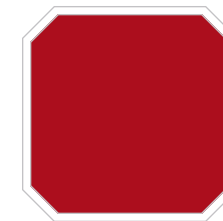

Bright Red

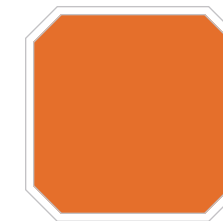

Omaha Orange

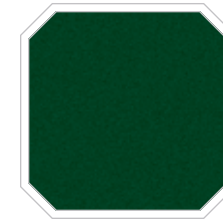

Holly Green

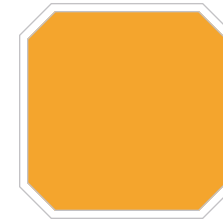

School Bus Yellow

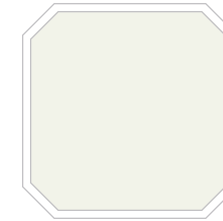

Winter White

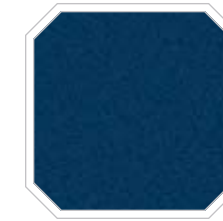

True Blue Metallic

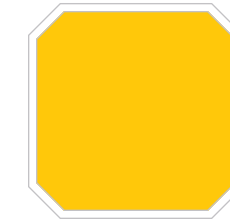

Bold Yellow

### Special Exterior Colours – F-650/F-750<sup>1</sup>

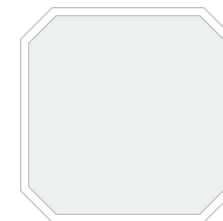

W0069A

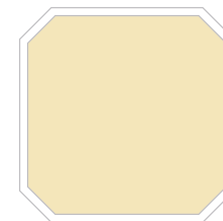

W1030B

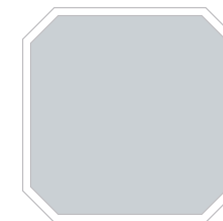

W2813C

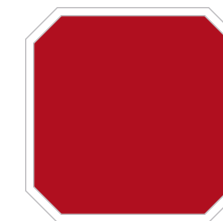

W4650D



W5685E

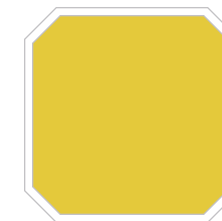

W6642F

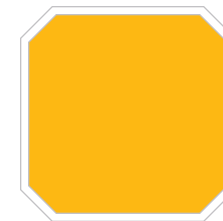

W6695F



W7406G

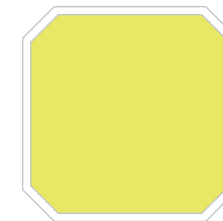

W7600G

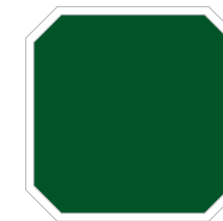

W7658G



W8002H



W8096H



W8866H

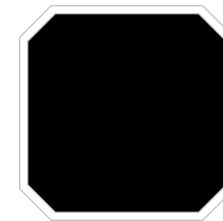

W7675G

<sup>1</sup>For quantities less than 5, contact your Ford of Canada Medium Truck Dealer.

Ford uses clearcoat paint for beauty and protection. Colours shown are representative only. Not all colours are available on all models. See your dealer for actual paint/trim options. Standard exterior colours shown. See your dealer for more information about availability and restrictions.