



OLDSMOBILE  
1988



THE TENTH DECADE  
VOL. I

TORONADO • NINETY-EIGHT REGENCY • DELTA SS ROYALE • CUSTOM CRUISER

## NINETY YEARS AGO, A CAR COMPANY WAS FOUNDED UPON THE PRINCIPLE OF OFFERING THE CUSTOMER VEHICLES OF SUBSTANTIAL QUALITY AND VALUE...

What we do and how we do it goes back to our very beginning in 1897, when the board of directors of the Olds Motor Works established this principle: "...to build one motor car in as nearly perfect a manner as possible." □ Are they



still built like they used to be? The answer is both yes. And no. □ Over the past 90 years, the machinists who built the early Oldsmobile models did so virtually by hand, and the production methods were crude at best. But the goal, then as now, was to build a quality car that every Olds owner could be proud of. □ Today, the people who design and build Oldsmobiles are products of the finest universities in the world and have at their disposal the latest and finest in computers and advanced electronics. □ The tools have changed. Our principle hasn't.

□ Through the years, Oldsmobile's continuing search for excellence has led to the development of numerous innovations that have not only changed

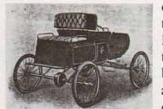

Oldsmobiles, but changed the face of the industry itself. Here are just a few such important advancements from Oldsmobile... & The Curved Dash Runabout at the turn of the century, with single-cylinder, 4-cycle engine. It enjoyed such universal acclaim, it became the first automobile to become the subject of a popular song—"In My Merry Oldsmobile." & With the introduction of the first fully automatic Hydra-matic Drive transmission, Oldsmobile virtually revolutionized how the world drives. New convenience and driving ease for the ever-growing driving public. & With Oldsmobile's introduction of its first high-compression V8, the Performance



Age was born! The V8-powered Olds 88 became the first of a record seven



Oldsmobiles to set the pace at Indy—and became a racing legend by capturing the

highly-sought-after NASCAR Grand National Championship—three consecutive years! & Oldsmobile has broken the styling mold too. Remember the *four-door* hardtop? That was Oldsmobile's Holiday Sedan. And, of course, there was Oldsmobile's

Vista-Cruiser, the first station wagon with a vista-view roof. & Also introduced by Oldsmobile—Olds Toronado, *Motor Trend* magazine's "Car of the Year" and the first contemporary personal luxury car with front-wheel drive. Today, of course, front-wheel drive is the rule. & For 1988, Oldsmobile features Quad

4, the revolutionary new 4-cylinder, 16-valve, dual overhead cam engine that powered the Olds Aerotech research vehicle (shown on the next page) in high-speed testing. The new Quad 4 engine will be available in Olds Cutlass Calais.

It could well become the *next* engineering legend. □ And so it goes at Oldsmobile, as it has for the past 90 years. Doing it better. Doing it right. Demanding a level of quality and dependability so

exacting, the Oldsmobile owner is assured lasting value, tangible value—over the miles—and the years.



## NOTHING'S CHANGED.



To you, our valued customer:  
If you could see what I have seen happening in the design studios, in the engineering groups, in the offices and plants, you would see what I see in the 1988 Oldsmobiles now available for your purchase at your Oldsmobile dealer. It's quality... quality of a very special kind. It's quality... quality of a very special kind. It began from the pride and commitment of one man, Ransom E. Olds, 90 years ago and is reformed today by the thousands of people who build, sell and service Oldsmobile automobiles. Oldsmobile quality does not exist, however, simply because we guard and value our reputation. It exists because we value you... your satisfaction, your enjoyment, your respect. And so, in 1988, it gives me especially great pleasure and pride to invite you, whether it is for your first or 91st time, to read about, test drive and purchase a new Oldsmobile and enjoy the many pleasures and advantages of Oldsmobile Quality.

*William W. Lane*  
William W. Lane  
Vice President, General Motors Corporation  
General Manager, Oldsmobile Division





**1988 OLDSMOBILE. FROM METALS THAT RESIST RUST... TO A WARRANTY THAT WON'T LET YOU DOWN.**

From Oldsmobile—some of the best-built and most corrosion-resistant Oldsmobiles that we've ever offered. And that excellence runs deep. It starts with metals that fight rust. Like galvanized steel and zincrometal. Each is used extensively throughout Oldsmobile bodies—from doors to hood to trunk lid and rocker panels. On some models, all exterior metal from the windows down is galvanized on both sides.

Nearly the entire body is immersed in a bath of rust-resistant primers, forming a tough, protective skin.

Nooks and crannies are treated with special hot waxes and zinc-rich primers for additional protection. Then the body is painted—with coat upon coat of lustrous enamel.

The anti-corrosion protection is so thorough and so effective that every 1988 Oldsmobile is backed with a new warranty that includes 6-year/100,000-mile rust-through protection.\* And the quality doesn't stop there. In fact,



engine, transmission and axle quality and dependability have reached such a level that every 1988 Oldsmobile is backed with a 6-year/60,000-mile powertrain warranty.<sup>2</sup> When you turn the key, the only surprises are pleasant ones.

<sup>2</sup>See your Oldsmobile dealer for the terms and conditions of this limited warranty.

**FROM OLDS INTERNATIONAL SERIES TO AN ELECTRONIC "OIL CHANGE REMINDER" THERE'S A LOT THAT'S NEW IN EVERY 1988 OLDSMOBILE.**

Throughout the 1988 Oldsmobile literature, you will be reading about all that's new. But here is a quick sampling of the year's highlights.

**New Oldsmobile International Series!**

Brand-new! And it's available in Olds Cutlass Ciera and new Cutlass Calais. The International Series features a European look, a special bucket seat interior and a sporty feel of the road.

Available in coupe or sedan, each is powered by a premium performance, fuel-injected engine—with 4-speed automatic over-drive transmission in Ciera and 5-speed manual in Calais. The suspension is Oldsmobile's sophisticated Level III (FE3) system. This special firm ride and handling package includes new performance



tires for outstanding traction—even on wet or snowy road surfaces.

If you love to drive, you've got to test drive the new Olds International Series Ciera and Calais!

**Facts at your fingertips!** With an available Driver Information System, pertinent facts are always at your fingertips.

This auto calculator instantly tells you your current MPG, ETA, driving range on remain-



ing fuel, miles to destination and more.

It even tells you when your oil is due for a change! When only 10% of the oil life remains, a reminder appears once a day which reads "CHANGE OIL IN (NUMBER) MILES." When the oil has been changed, simply reset the system with the push of a button.

This system is especially important because oil-change intervals vary with each individual car, depending on individual driving habits and climatic conditions.

User-friendly, this auto calculator has large button graphics. Minimum driver input is required. Try it. It's easy and informative. Available in Cutlass Calais, Cutlass Ciera, Delta 88 and Ninety-Eight with specific fuel-injected engines.



**Anti-lock braking for smooth, controlled stops in virtually any situation.**

You're cruising along a rain-slicked freeway, the traffic heavy and moving fast. Suddenly the driver in front of you slams on his brakes. Do you panic? Not with advanced ABS—the Teves electronic anti-lock braking system.

A sensor at each wheel constantly monitors the speed of that wheel and feeds the data to a microprocessor. Hit the brakes in an emergency situation, and the microprocessor assists by sending commands to apply brake pressure up to 15 times per second to make

corrections and to provide stable, lock-up-free stopping power when you need it most. Anti-lock braking is standard on Olds Touring Sedan and available on Toronado Trofeo, Toronado, Ninety-Eight and Delta 88 models.

**New in-car storage convenience.**

Available in Cutlass Ciera, Delta 88 and Ninety-Eight—a new storage armrest that's just right for your car phone, cassette tapes or personal belongings. Helps keep your interior neat and clean.



**New new utility for a sporty, sophisticated Olds.**

That's Olds Cutlass Calais, SL and International Series, with their new split-folding rear seat—with open cargo area to the trunk. Fold down the split seat back, and you can carry skis or golf clubs, as well as a rear seat passenger. Or fold down the entire seat back and carry even larger tools or toys.

**New 3-way power sunroof for Ciera.**

It's a sunroof. It's a refreshing vent. It's a shaded roof. It's your choice—with Cutlass Ciera Sedan's new available 3-way power sunroof. Just pick the mode that suits your mood.

**New driver-side inflatable restraint.**

Available on Olds Delta 88 Sedan models for 1988. The specially designed steering wheel has a new, compact, inflatable restraint (airbag) system built in. The adjustable Tilt-Away feature is also included.

**New looks, new lights for Firenza.**

For 1988, Olds Firenza features a stylish new grille and aerodynamically smooth composite headlamps. High beams are

halogen lamps for excellent down-the-road viewing. Firenza also features larger tires for impressive ride and handling.



**New 3-point safety belts for rear seat passengers.** They are as comfortable and easy-to-use as front seat belts. Simply bring the belt across your lap and "click." You're belted—with both shoulder and lap restrains. Standard on all Olds Delta 88 and Toronado models. The belts store neatly against the seat when not in use.



**New convenience when ordering options!**

Options that have proven to be especially popular have now been grouped into convenient new option packages. This makes ordering simpler. And in some cases, more affordable—based on comparison of manufacturer's suggested retail price of option package versus options if purchased separately. See your salesperson for details.

**Customer satisfaction—sale after sale.**

Customer satisfaction is never automatic. You have to work at it. And we do. In fact, every Oldsmobile dealer is an active participant in Oldsmobile's Par Excellence Customer Satisfaction Commitment Program to provide quality service and sales professionalism. Is it working? According to you, our customers, the answer is a resounding YES!

**OLDSMOBILE TOURING SEDAN: THE DRIVING EXPERIENCE FOR EXPERIENCED DRIVERS.**

With the new 3.8 SFI 3800 V6 engine, sophisticated Level III (FE3) suspension and leather in the seating areas, Touring Sedan

is Oldsmobile quality in its most magnificent form. A special Oldsmobile Touring Sedan brochure is available.

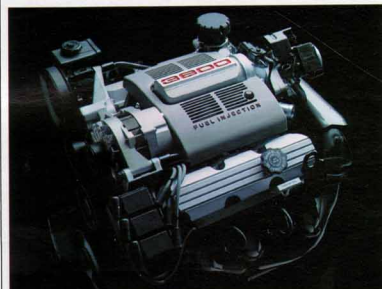

**NEW 3.8 SFI 3800 V6 PROVIDES PREMIUM PERFORMANCE FOR DELTA 88, NINETY-EIGHT AND TORONADO!**

Oldsmobile introduces the new 3800 sequential port fuel-injected V6 engine! Lightweight metals and state-of-the-art technology make it an impressive balance of power and smoothness. Standard in Ninety-Eight and Toronado and optional at no extra cost in Delta 88, the new 3800 V6 features special lightweight pistons, to help provide smooth running performance.

Performance is further enhanced by the tuned intake manifolds and large diameter exhaust "take down" pipes. The results: low back pressure and impressive performance.

Fuel is injected directly into each intake port by a high-

pressure turbine pump at exactly the right time and with exactly the right fuel/air mixture—at every speed. Each injector is sequentially activated with new state-of-the-art crankcase sensor technology.

By signaling the engine every microsecond (about 84 times a second), the engine responds with optimum performance, smooth operation and minimized exhaust emissions.

The new 3800 sequential port fuel-injected V6. It's one great engine. Go enjoy one great test drive!

But that's just a part of the big engine news from Oldsmobile for 1988. Turn the page, and learn about the exciting new Quad 4 engine, available in Olds Cutlass Calais!



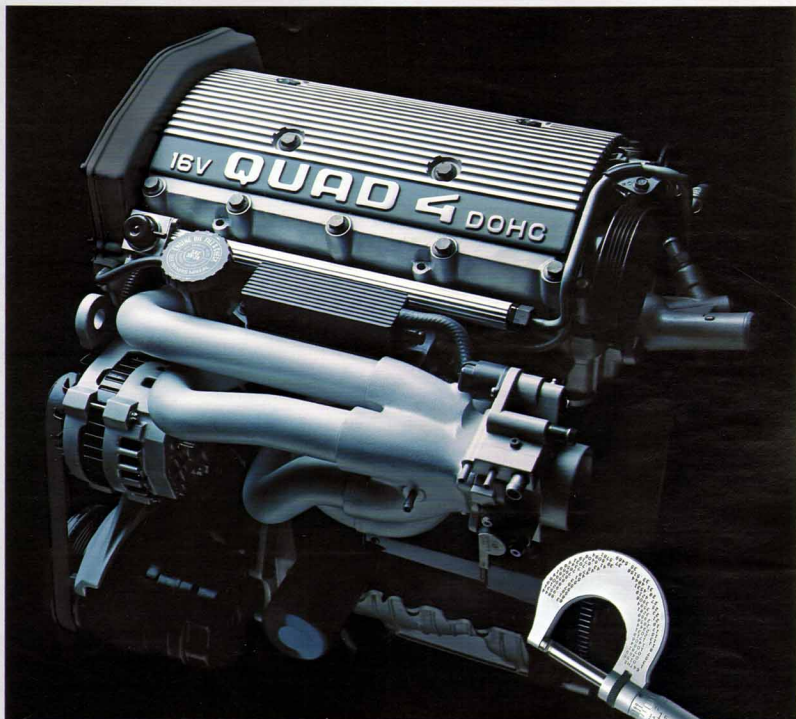

**FROM A BLANK SHEET OF PAPER TO ONE OF THE FINEST ENGINES OFFERED BY GENERAL MOTORS.**

A big part of the Oldsmobile commitment to quality is a commitment to the future. To new and innovative products like the Quad 4 engine—a 2.3-liter, 4-cylinder,

dual overhead cam, 16-valve engine developed to deliver remarkably high horsepower for its displacement. But the future is coming at you faster than you think, because Quad 4 is available in Oldsmobile Cutlass Calais models after November 1, 1987.

Now, what started as a blank sheet of paper is a revolutionary new engine that incorporates the most modern technologies in the

industry today. The Quad 4 is designed to provide world-class quality, reliability and durability. It delivers smooth, dependable and truly outstanding performance. But Oldsmobile



Oldsmobile Aerotech research vehicle

wanted still more. Hence, the Oldsmobile Aerotech—an exclusively designed research vehicle developed and built for the express purpose of testing the Quad 4 engine and putting it through some of the toughest paces ever known. The Quad 4 and the Oldsmobile Aerotech. Oldsmobile quality—in impressive form.

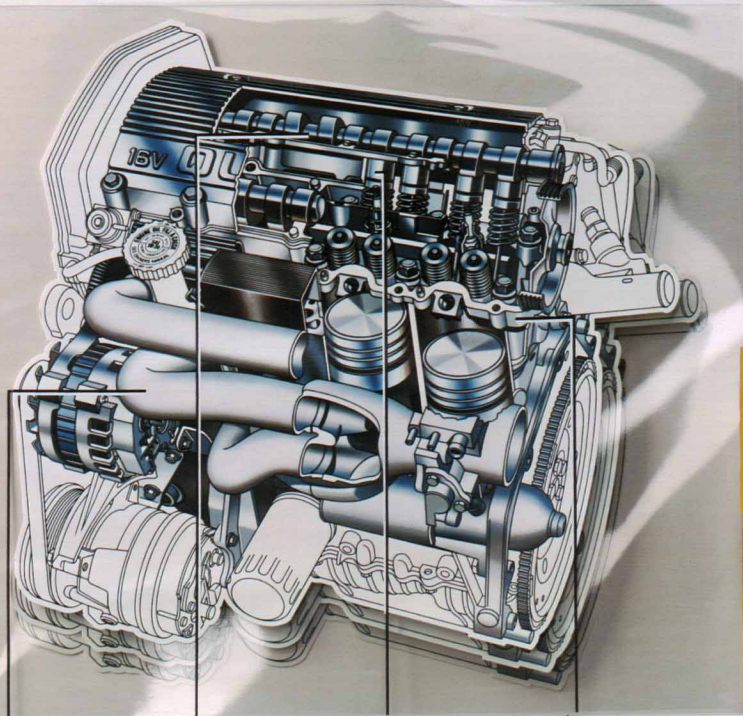

*High-flow/high-velocity intake and exhaust ports are alcohol resistant for increased durability. Manifolds are newly engineered and highly tuned for optimum output and minimum displacement. The result is remarkably high horsepower in relation to engine displacement. Quad 4 doesn't need to work as hard to deliver more power than conventional engines.*

*The Quad 4 incorporates an efficient overhead cam configuration. Engine components including the camshaft, cam carriers and cam carrier covers are tooled in-plant. Computer-precise statistical and quality control is maintained in conjunction with actual assembly.*

*A "simultaneous double fire" multipoint fuel injection system is combined with an integrated direct ignition system. No distributor or secondary spark plug wires are used, and hydraulic valve lifters are also minimum mechanical/direct acting, without the use of a rocker arm. The complexity of the engine is reduced.*

*The crossflow coolant designed 16-valve cylinder head is made of cast aluminum alloy. Coolant distribution around the cylinder bores is insured by three machined apertures within each passage. Coolant passes through a tubular manifold system for optimum distribution and complete temperature control.*

16-VALVE CYLINDER HEAD DUAL OVERHEAD CAM

DELTA 88 ROYALE p. 27

NINETYEIGHT REGENCY p. 19

TORONADO p. 11

**BEHIND EVERY OLDSMOBILE INTERIOR, THERE ARE THOUSANDS OF PEOPLE WORKING TO MAKE SURE THE BEST SEATS IN THE HOUSE ARE ON THE ROAD.**

Mechanically, more design and engineering expertise go into the construction of an Oldsmobile's seats than in the seating for most any other application in life.

Examples of Olds' three seating configurations and a detailed inside look at their design technology are shown below.

Each seating style shares a common Oldsmobile trait...the purpose to help you feel at one with your Oldsmobile, ease your drive and support you pro-

portionately with no points of noticeable pressure. The interior is also designed to complement the attitude and road handling attributes of the Oldsmobile of which it is a part. Yet, where your Oldsmobile outshines even a sumptuous living room or high-tech airline seating is this...the trend-setting design-excellence of Oldsmobile interior fabrics, color and trims.

Each year, stylists, designers and engineers look at well over 1,000 fabric samples from the top textile mills in the country.

Of those, six, seven, maybe ten will be good enough to make it into your new Oldsmobile. Good enough looking. Good enough wearing. Correct in

statement and purpose, with all the color, style and strength characteristics we believe are essential to being good enough for an Oldsmobile.

Color, texture and weave are totally analyzed for the design statement they create. Is it elegance (light pinstripes, pindotted velours and herringbone grays)? Or sportiness (light on dark horizontal stripes or plaids)?

And what about wearability and durability? The inside of a parked automobile can reach temperatures as high as 275°F or as low as 50°F below.

So the fabric and materials used in Oldsmobiles are put into an oven, subjected to precisely measured sunlight and ultraviolet rays in the

lab and on location in Florida and Arizona, and then chilled to well below zero.

Before and after, they twist. They bend. They crumple and they rend. And they do it time and time again to push the limits of fabric technology. The sewing thread is subjected to even more rigid testing.

The result is to simulate the wear and tear a car will endure over a five-to-ten-year period. The goal, with normal owner use and care, is to retain a like-new look for five years. No threadbaring, rips or tears for ten.

Oldsmobile leathers have also reached levels of sophistication comparable to fabric technology. New

chromium-tanning techniques, as well as the application of polymer coatings, have achieved leather upholstery that is durable, yet soft and supple with good moisture absorption characteristics.

Colors are chosen for their ability to blend and harmonize over 100 or more different materials. Even the shine of each material's surface is precisely measured to make sure that the surfaces that should not cause reflective glare, don't.

This same meticulous care is applied to instrumentation, visors, compartments, trims and hardware.

The burled walnut on the instrument panel of the Oldsmobile Touring Sedan, for instance, is difficult to obtain and more difficult still to properly form and finish.

Yet, in this Oldsmobile, this sensitive wood features the highest gloss possible, through the use of a polyester finish which is applied and sanded seven times. Seven times. This is crafts-

manship of the sort you may have thought long gone. Not on an Olds. Every 1988 Oldsmobile, from the Touring Sedan to the Cutlass Calais International Series to the Firenza, features the same care and expertise.

The reason is simple. It is the Oldsmobile way. The Oldsmobile tradition. The Oldsmobile commitment.

It is Oldsmobile. And you know it from the moment you get inside and take a seat. It is the touch, look and feel of Oldsmobile quality.

*Headrest integrated with the design of the seat back. Object: Contour integrity and head and neck support. (Power articulating on Olds Touring Sedan models.)*

*Reinforced steel shell seat structure provides the most desirable positioning and structural support in a space-saving form.*

*Seat cushioning of high-resilience, long-lasting polyurethane foam. Provides an optimum combination of support, softness and shape retention over time. A well-defined substrate formed to the ergonomic needs of most drivers.*

*Lumbar and lateral back support fully power-operated for the Touring Sedan and Trofeo. Power thigh support adjustments. (Olds Touring Sedan models.)*

*Manual seating provides a studiously-arrived-at seat height which meets the comfort needs of 95% of all drivers. And front/rear seat movement provides a full range of leg position choices to suit driver and passenger alike.*

*Power seats: The best 6-way power adjusters available allow drivers and passengers to adjust seating height, tilt, and front/rear distance over an amazing range of positions.*

*Seat track and manual or power adjusting designed to provide the maximum range of comfort that advanced seating technology allows.*

*New Oldsmobile special power reclining bucket seats. Standard on Olds Touring Sedan and Toronado Trofeo. Available on Ninety-Eight and Delta 88 Royale with passenger side recline only.*

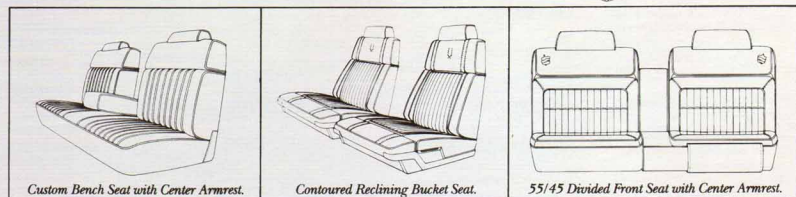
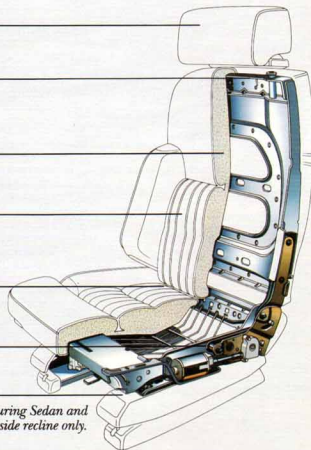

Custom Bench Seat with Center Armrest.

Contoured Reclining Bucket Seat.

55/45 Divided Front Seat with Center Armrest.

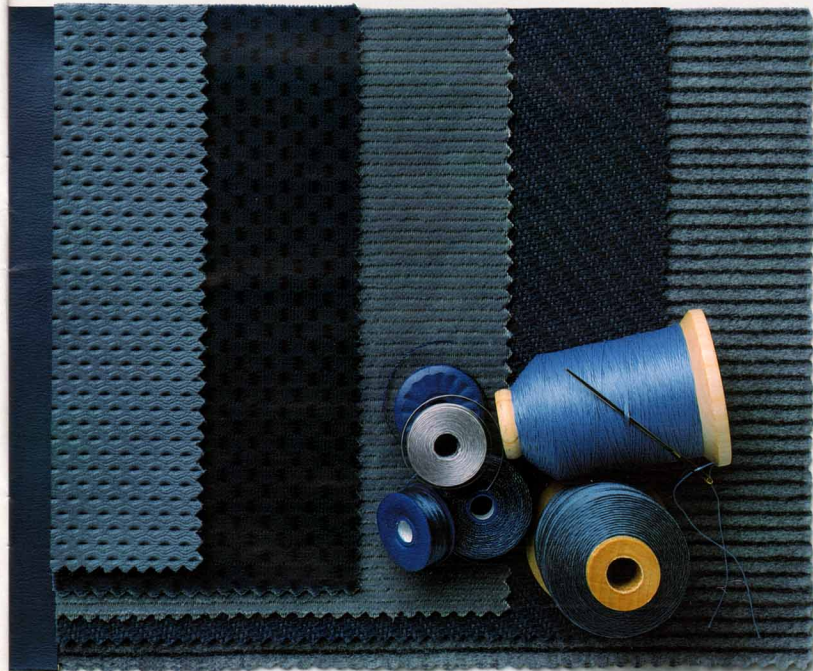

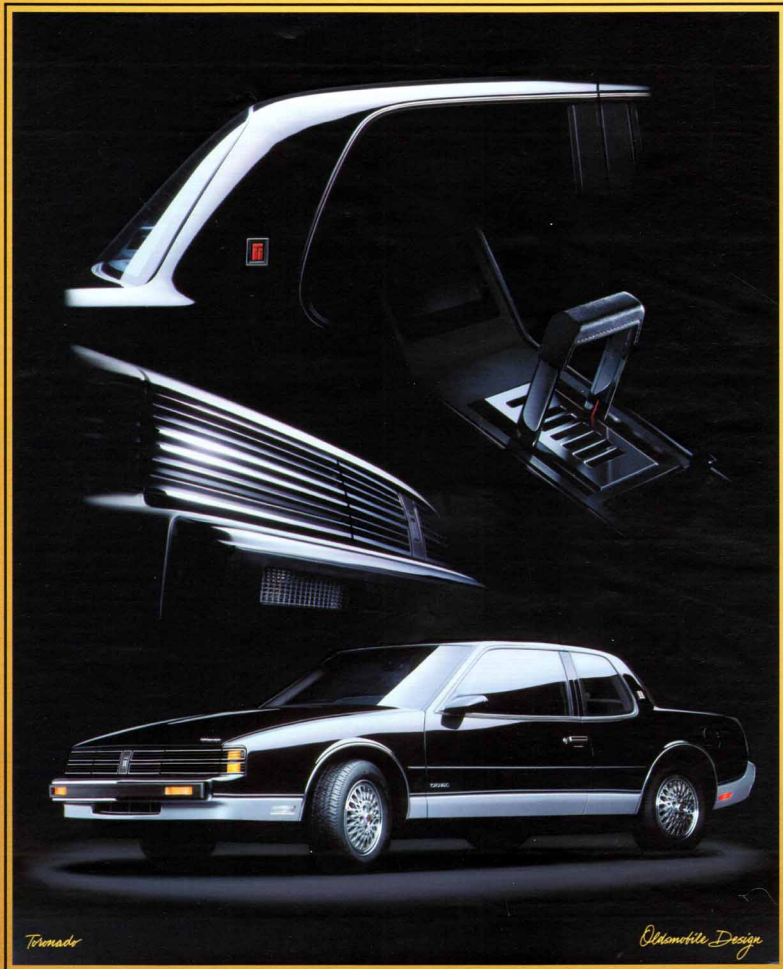

## TORONADO

SET IT IN MOTION,  
AND YOU DISCOVER A  
WHOLE NEW LUXURY.

---

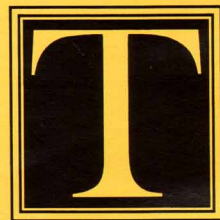

*Oldsmobile Toronado has never held to traditional luxury standards. Always, it has stood alone. Always, it has been the driver's car. The very first Toronado, for example, introduced contemporary front-wheel drive—some twenty years before it was the prevailing fashion. Today, Oldsmobile Toronado remains a unique and exhilarating driving experience. Its look is purely Toronado, with bullet-shaped aerodynamic lines that slice through air—and mediocrity—with equal ease. Dramatic and sophisticated, Toronado is the very shape of luxury performance. And that performance is premium—with the introduction of the new 3.8 SFI 3800 V6 engine with Sequential Port Fuel-Injection. A power plant so capable, no other engine choice need be made available. For those who can afford any car in the world, there is a car like no other in the world. From Oldsmobile, the 1988 Oldsmobile Toronado.*

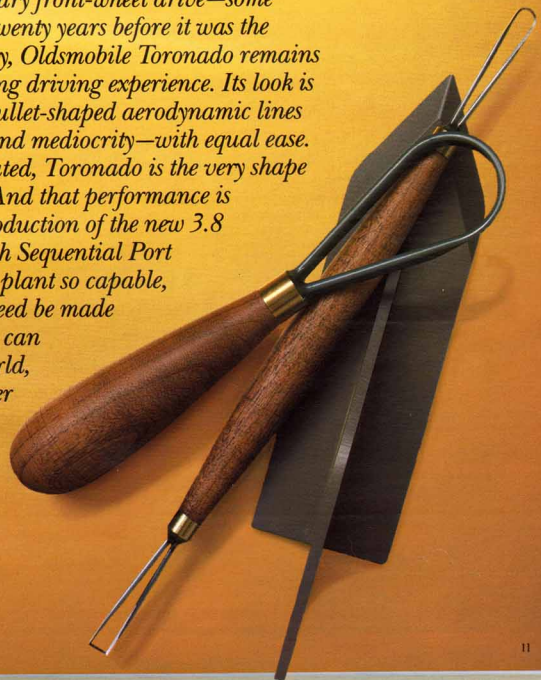

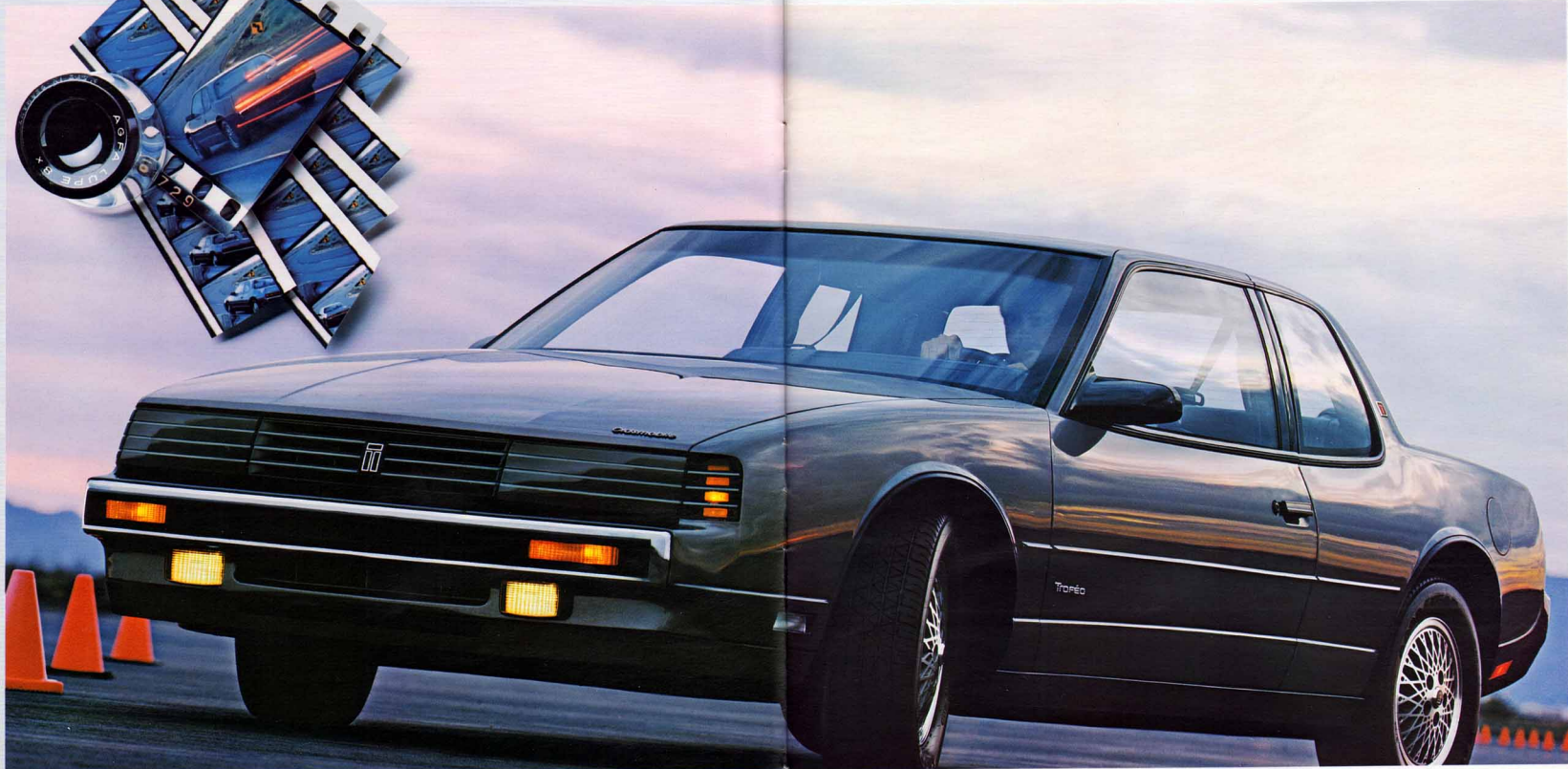

**TORONADO TROFÉO**  
**FEW CARS IN THE WORLD,**  
**AT ANY PRICE, MATCH ITS**  
**DRIVING CAPABILITIES.**

The 1988 Troféo is the ultimate Tornado. An ultimate personal performance luxury coupe. It is

equipped with the most precise, most sophisticated underpinnings ever offered in an Oldsmobile.

Several years in development and millions of miles of perfecting, it is really four individual suspension systems. One at each 15-inch wheel.

MacPherson front struts are computer-matched with special firm ride shock absorbers, larger diameter

stabilizer bars and higher rate springs. The 4-wheel disc brakes feature an available anti-lock system.

What it all means is perhaps one of the sweetest driving personal luxury coupes you've ever driven. In proving-ground tests, with professional drivers, its lateral acceleration score, how

quickly a car can enter and take a turn, was a remarkable .81G.

And few cars match Troféo's dramatic look, with black grille and trim, retractable headlamps and available Firemist finish.

If you're looking for some straight answers about road handling and maneuverability, the place to ask is in the turns—behind the wheel of the Toronado® Troféo.

*1. Smoke gray tail lamp lenses for distinction. Low back pressure dual exhaust for performance.*





**AT THE TOUCH OF A FINGER, THE TROFEO SEAT FORMS ITSELF TO THE DRIVER AND FRONT PASSENGER.**

Certainly, the seating in a world-class road coupe must be lavish in its comfort. But it must be far more ambitious. It must provide firm support, enhance driver skills, and help keep you in control. Toronado Trofeo seats have been meticulously designed and engineered to accomplish exactly that.

Firm bolsters line each side of this Lear Siegler seat, along the thigh and back, to hold you securely in place. At the touch of a finger, the seat raises, lowers, moves fore and aft, and tilts. Activate the console-mounted power lumbar switch, and the seat forms to

the exact contours of your back. A second control adjusts the power reclining seat back to the exact position you prefer. Both driver and passenger seats, shown above with genuine leather in the seating areas, are independently and infinitely adjustable to accommodate most any size person. Choose from Medium Gray, Dark Sapphire Blue or Dark Garnet Red.

3-point safety belts front and rear. At Oldsmobile, quality is serious business. Slip into Trofeo. Buckle up. And feel it for yourself.

1. Instrumentation is electronic. The message center now reminds when to change oil. Leather-wrapped steering wheel, Trofeo.  
2. Toronado interior with 55/45 divided front seat. Sierra grain leather available in seating areas.

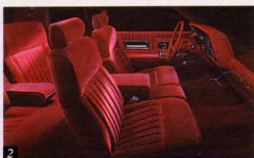

*The Toronado Trofeo interior, like Trofeo itself, creates a personal, no-nonsense style that strips away all but the essential. Featured in the seating areas is genuine perforated Morocco leather.*

*For added strength and durability, Doeskin vinyl trims the seat, instrument panel and door panels.*

*The center console is highlighted with a graphite-on-metal combination for a striking, contemporary appearance.*







New 3.8 SFI 3800 V6

Electronic analog instrumentation with tachometer and reminder package

4-speed automatic overdrive transmission

Roomy, space-efficient interior

Two-sided galvanized steel body

4-wheel power disc brakes

4-wheel independent suspension

Automatic leveling system

**THE CULMINATION OF 90 YEARS OF ENGINEERING EXCELLENCE COURSES THROUGH TORONADO'S BLOODLINES.**

**TORONADO POWERTRAIN SPECIFICATIONS**

	STANDARD
<b>ENGINE</b>	
Displacement	3800 cc
Engine	V6
Break HP (rpm)	165 @ 5200
Net torque (lbs. ft.)	215 @ 2000
Bore/Stroke (in.)	3.800/3.400
Compression ratio	8.5 to 1
Fuel management	Electronic Fuel Injection (Sequential port)
Cooling system (qt.)	11.97

**DRIVELINE**

Transcase	4-speed overdrive automatic
Final drive ratio	1.57 to 1

**SUSPENSION/HANDLING**

Front	MacPherson struts, coil springs
Rear	Transflex fiberglass independent
Front turning diameter curb to curb, left/right (ft.)	11.57/12.298
Recommended trailer towing maximum capacity (lbs.)*	2000

\*Recommended maximum capacity when properly equipped. Includes passengers, cargo and equipment.

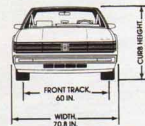
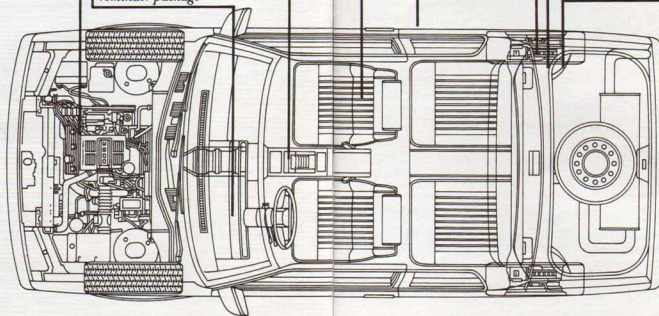

**TORONADO DIMENSIONS**

BODY/CHASSIS	COUPE
Wheelbase (in.)	108.0
Track, front/rear (in.)	60.0/60.0
Tire size	P205/75R14
Wheel size	14 x 6.5
Brake type, front/rear	Disc/Disc
Fuel tank (gals.)	18.0

**EXTERIOR**

Length (in.)	187.5
Width (in.)	70.8
Height (in.) (curb)	53.0
Curb weight (lbs.)	3364

**INTERIOR**

Headroom, front/rear (in.)	37.8*/37.8*
Luggage room, front (cu. ft.)	42.7/35.7
Shoulder room, front/rear (in.)	58.3/57.5
Seating capacity	5
Trunk capacity (cu. ft.)	14.1

\*Headroom is reduced when Astorof is installed.

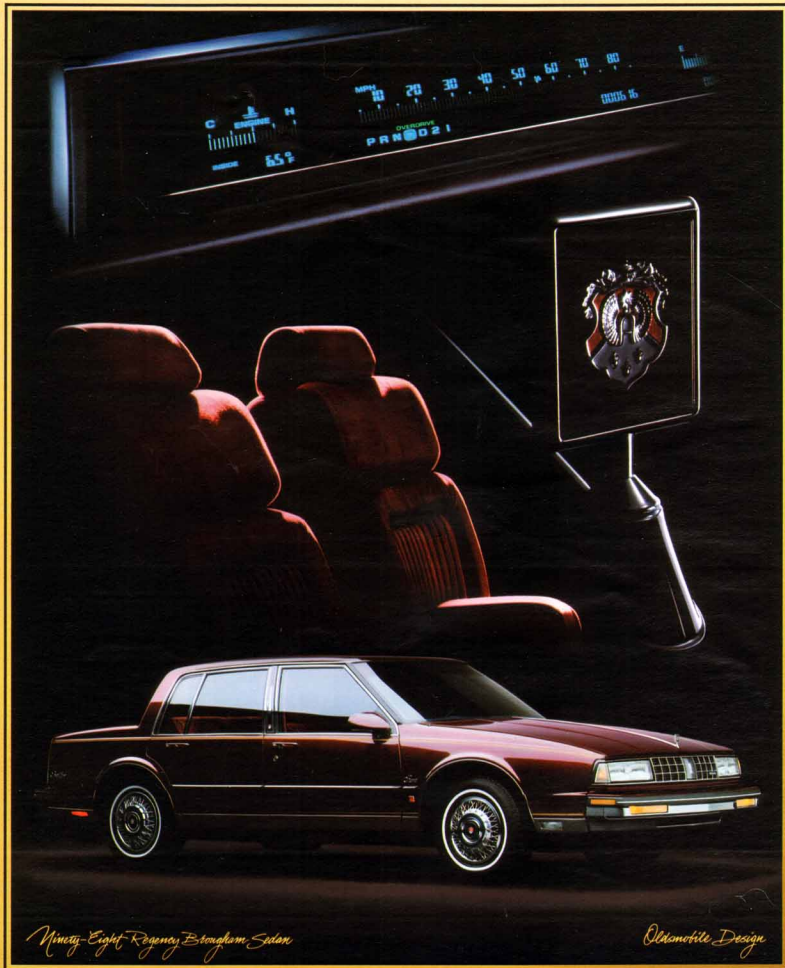

## NINETY-EIGHT REGENCY

DESIGNED FOR PEOPLE WHO CAN AFFORD  
TO SPEND TWICE AS MUCH FOR A CAR.  
BUT ARE INTELLIGENT ENOUGH NOT TO.

**N**

*You are not one to make hasty or capricious decisions. You find it more comforting and reassuring to be guided by considered judgment rather than impulsive emotion. Before you lose your heart to a luxury car, you first engage your head. You check and*

*double-check all the factors very closely. Initial sticker price? You find that a Ninety-Eight Regency is substantially less than many other luxury sedans, foreign or domestic. What about resale value? Here, again, you learn Regency's is traditionally high, year after year returning a substantial portion of the original investment. Your heart is won over, but your head keeps digging for more information, more buying justification. What about luxury? What about room and comfort? Ride and handling? And what about quality and dependability? Your head is now satisfied, and it's safe to let your heart take over. Ninety-Eight Regency has passed the test.*

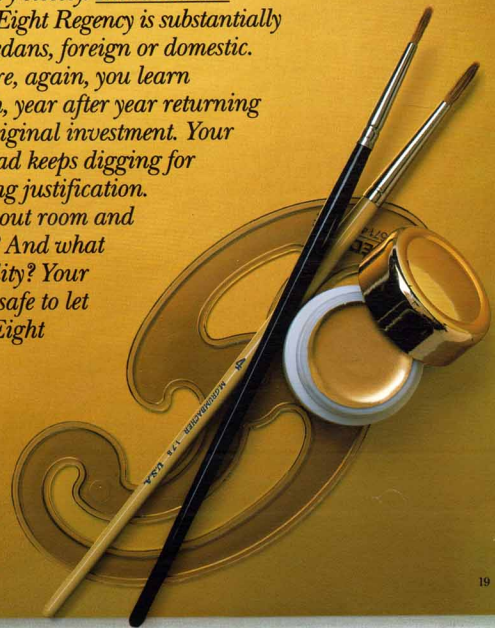



NINETY-EIGHT REGENCY Brougham Sedan

**THE TRUE MEASURE OF A LUXURY CAR IS NOT "GLITZ." IT IS THE COMFORT AND WELL-BEING OF THE DRIVER AND OCCUPANTS.**

The "glitz" we gladly leave to others. Luxury in a Ninety-Eight Regency Brougham is understated but substan-

tive, creating a harmonious environment for the people within.

It is roomy and elegantly appointed interiors to please the senses. It is also ergonomically designed seating to give respite to the body.

It is the controlled smoothness of the ride and the accuracy of the steering. It is Regency Brougham's standard Level I ride system, where

all the elements work in splendid cooperation: front-wheel drive, rack-and-pinion steering, four-wheel independent suspension and automatic electronic load leveling.

To these, Level II adds an available firm ride suspension, and Level III, a touring car suspension with special aluminum-styled wheels and larger 15-inch tires.

Ninety-Eight Regency Brougham is powered by the new 3.8 SFI 3800 V6. It delivers impressive response and performance. Pages 40-42 record the many standard and intriguing available features which grace this quality-inspired Olds.

1. and 2. Available anti-lock braking system.

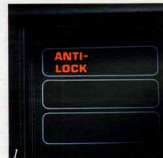



**THE QUALITY COMES SHINING THROUGH, RIGHT DOWN TO THE LAST STITCH.**

It would not be an exaggeration to describe the interior of the Ninety-Eight Regency Brougham as the "lap of luxury."

Consider the body-cradling comfort of the divided full-foam seats. The plush opulence of the Elite velour fabrics, or the available leather in the seating areas. The thick cut-pile carpeting. The rich wood-grain applique. Quality was never in better shape.

1. Elite velour fabrics grace Ninety-Eight Regency Brougham models. 2. Available front storage armrest holds cellular phone, tape cassettes, etc. Moves upright when not in use. 3. Available Delco/Bose music system provides concert-hall reception. 4. Ninety-Eight Regency models with their Prima II velour interiors invite you to sit back, relax and enjoy the surroundings.

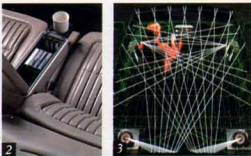

Elite velour fabrics highlight Regency Brougham interiors and are available in Dark Sapphire Blue, Medium Gray, Dark Garnet Red, Medium Antelope and Dark Rosewood.

Wood-grain applique adds a gracious note of elegance to the steering wheel, instrument and door panels.

With available leather in the seating areas, color-matched Doeskin vinyl trim is used where heavy wear and ease of cleaning are important.



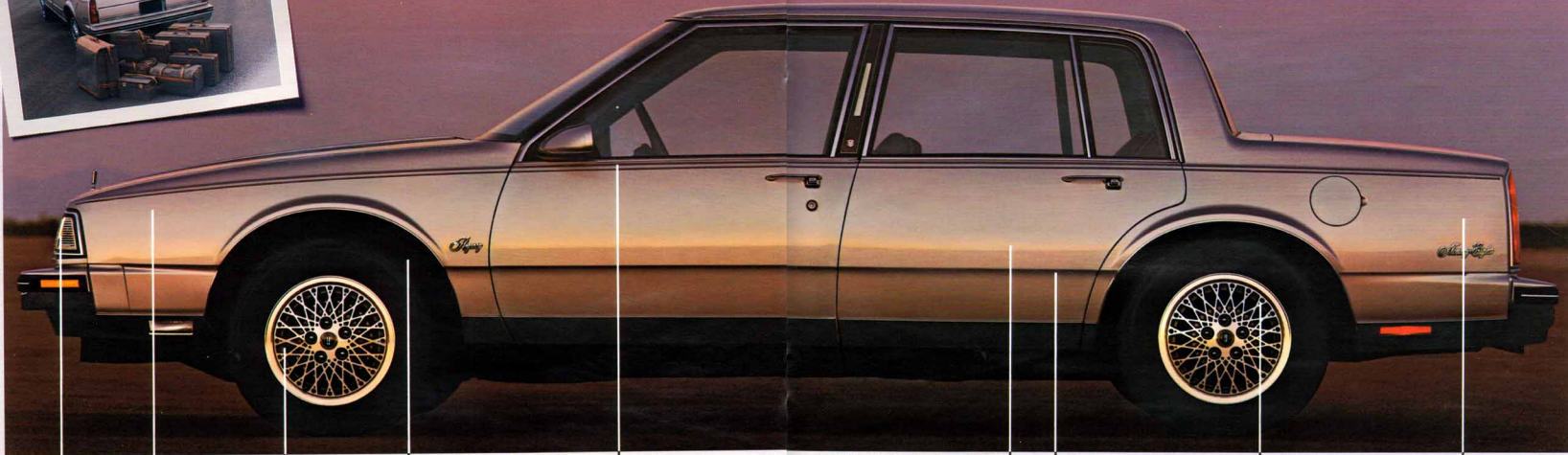

NINETY-EIGHT REGENCY  
Specifications/Dimensions

DELTA 88 ROYALE p. 27

- Composite headlamps
- New 3.8 SFI 3800 V6
- Front-wheel drive
- Power rack-and-pinion steering
- 4-speed automatic overdrive transmission
- Multicoat/high-gloss enamel finish
- Two-sided galvanized steel for added protection against corrosion
- Four-wheel independent suspension
- Automatic electronic load leveling

**HIGH-TECH ADVANCEMENTS AND SERIOUS ENGINEERING COMMITMENT ADD MEASURABLY TO QUALITY, DURABILITY AND DRIVING SATISFACTION.**

**NINETY-EIGHT REGENCY POWERTRAIN SPECIFICATIONS**

ENGINE	STANDARD
Displacement	3800 cc
Engine	V6
Break HP (rpm)	165 @ 5200
Net torque (lbs. ft.)	215 @ 2000
Bore/Stroke (in.)	3.800/3.400
Compression ratio	8.5 to 1
Fuel management	Electronic Fuel Injection (Sequential port)
Cooling system (qt.)	12.37

**DRIVELINE**

Transaxle	4-speed overdrive automatic
Final drive ratio	1.57 to 1

**SUSPENSION/HANDLING**

Front	MacPherson struts
Rear	Semi-independent
Front turning diameter curb to curb, left/right (ft.)	38.7/39.1
Trailer towing capacity (lbs.)*	2000

\*Recommended maximum capacity when properly equipped. Includes passengers, cargo and equipment.

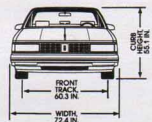
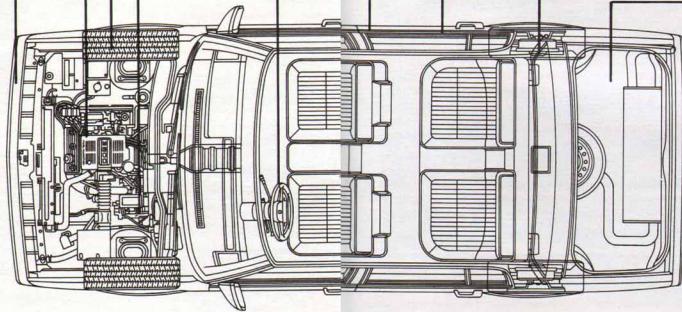

**NINETY-EIGHT REGENCY DIMENSIONS**

SEDAN	SEDAN
Wheelbase (in.)	110.8
Track, front/rear (in.)	60.3/59.9
Tire size	P205/75R14
Wheel size	14 x 6
Brake type, front/rear	Disc/Drum
Fuel tank (gals.)	18.0
<b>EXTERIOR</b>	
Length (in.)	196.4
Width (in.)	72.4
Height (in.) (curb)	55.1
Curb weight (lbs.)	3316
<b>INTERIOR</b>	
Headroom, front/rear (in.)	39.3/38.1*
Legroom, front/rear (in.)	42.4/41.5
Shoulder room, front/rear (in.)	58.9/58.8
Seating capacity	6
Trunk capacity (cu. ft.)	16.4

\*Headroom is reduced when Astroroof is ordered.



*Delta 88 Royale Brookham Sedan*

*Oldsmobile Design*

## DELTA 88 ROYALE

*WHAT THIS COUNTRY NEEDS  
IS A ROOMY, SUBSTANTIAL CAR.  
AND THAT'S WHAT THIS COUNTRY  
GETS FROM OLDSMOBILE.*

**D**

*It's big and roomy. Solid and substantial. It's the family car that didn't forget the family—Delta 88 Royale. There's plenty of room for a family of six. And plenty of comfort, too, on those full-foam seats. Since families operate on a budget, they need a car that can stay within one. And that's Delta 88 Royale, too. First of all, the price is affordable, and you can tailor it to your monthly budget. And you get so much for your money—so many features are standard equipment: power steering and brakes, tinted windows all around, side-window defogger, Four-Season air conditioning, and Delco AM/FM stereo radio and digital clock. For 1988, all Delta 88s feature a front-seat automatic safety belt system, except Delta 88 sedans when equipped with available inflatable restraint system and active belts. Rear seat passengers are secured by a new three-point shoulder belt system. One other point about quality. Two-sided galvanized steel protects the entire lower body, contributing to high value at resale time.*

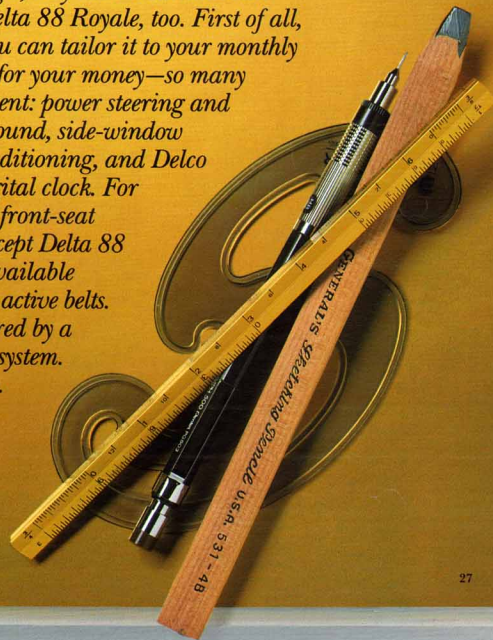

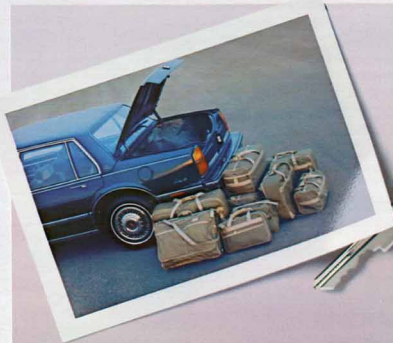

**YEAR AFTER YEAR,  
OWNERS SAY, "IT'S A  
GOOD FEELING TO HAVE  
THIS OLDS AROUND YOU!"**

Delta 88 is a longstanding favorite with America's families, and the Royale Brougham Coupe quickly explains

the popularity. It is, first and foremost, a roomy, substantial car, solidly built for years of reliable service. Curb weight: 3,214 pounds. Trunk capacity: 16.2 cubic feet.

For all its practicality, though, it is unabashedly luxurious and makes no bones about it. After all, families appreciate luxury, too.

So a tinted sunroof is available. Gen-

uine leather in the seating areas and the Driver Information System described at the right, also available. A Delco ETR AM/FM stereo with seek-scan, auto-reverse cassette, digital display clock and extended range dual rear speakers is standard.

As you drive, a 3.8-liter sequential

port fuel-injected V6 and 4-speed automatic overdrive transmission keep you in command. The ride is smoothed with a four-wheel fully independent suspension.

A good feeling, all around.

*1. Driver Information System available for 1988—more "user friendly," more legible displays, better graphics. Features include digital readout of fuel economy, range and fuel used, time and elapsed time, next oil change required, etc.*





DELTA 88 ROYALE  
Brougham Interior

**UNHEARD OF  
THE NOISES THAT HAVE  
BEEN SNUFFED OUT,  
MUFFLED OUT, AND JUST  
PLAIN ELIMINATED.**

It would be a shame to have this beautiful Royale Brougham setting spoiled by wind noise, road noise or high-pitched vibrations. And the engineers made certain it's not—applying acoustical wizardry—to help keep everything serene and blissfully quiet.

*Interior above shown equipped with inflatable restraint option.*

1. Driver and right front passenger enjoy the security of automatic front safety belts, standard on all Delta 88s. 2. Custom bench seat on Delta 88 Royale in Lucerne knit velour. The cut-pile carpeting extends up into the door panels. 3. Royale Brougham owners can order optional leather for the seating areas.



*Elegant-looking yet hard-wearing and easy-cleaning, these Elite velours on Royale Brougham models come in Dark Sapphire Blue, Medium Gray, Dark Garnet Red, Medium Antelope and Dark Rosewood.*

*They look smart. They wear well.  
They wipe clean.*

*The handsome Delta 88 Royale interior is accented by Sheffield "brushed aluminum" applique.*







DELTA 88 ROYALE  
Coupe

**HOW TO CONVERT A NICE,  
PERFECTLY RESPECTABLE  
DELTA 88 ROYALE INTO ONE  
EXCITING ROAD MACHINE.**

Transforming a fine family car into a road-hugging performance vehicle is now easy to do. Just order the avail-

able Level III (FE3) Touring Car Ride and Handling suspension, the firmest Oldsmobile offers.

It combines MacPherson front struts with four-wheel independent suspension, automatic electronic load leveling, special aluminum-styled 15" wheels and tires.

With Level III, the spring rates have been increased, bushings are firmer,

stabilizer bars larger, shock absorber valving more resilient than the standard suspension.

The results are nothing less than spectacular with low lean and sway on curves. Steering is pinpoint-accurate. The ride is sure and steady.

For 1988, the standard engine is the 3.8-liter V6 with sequential port fuel injection. But the new premium performance 3.8 SFI 3800 V6 is optional at no extra cost. With tuned intake manifolds and larger diameter exhaust piping, it reduces back pressure and adds performance.



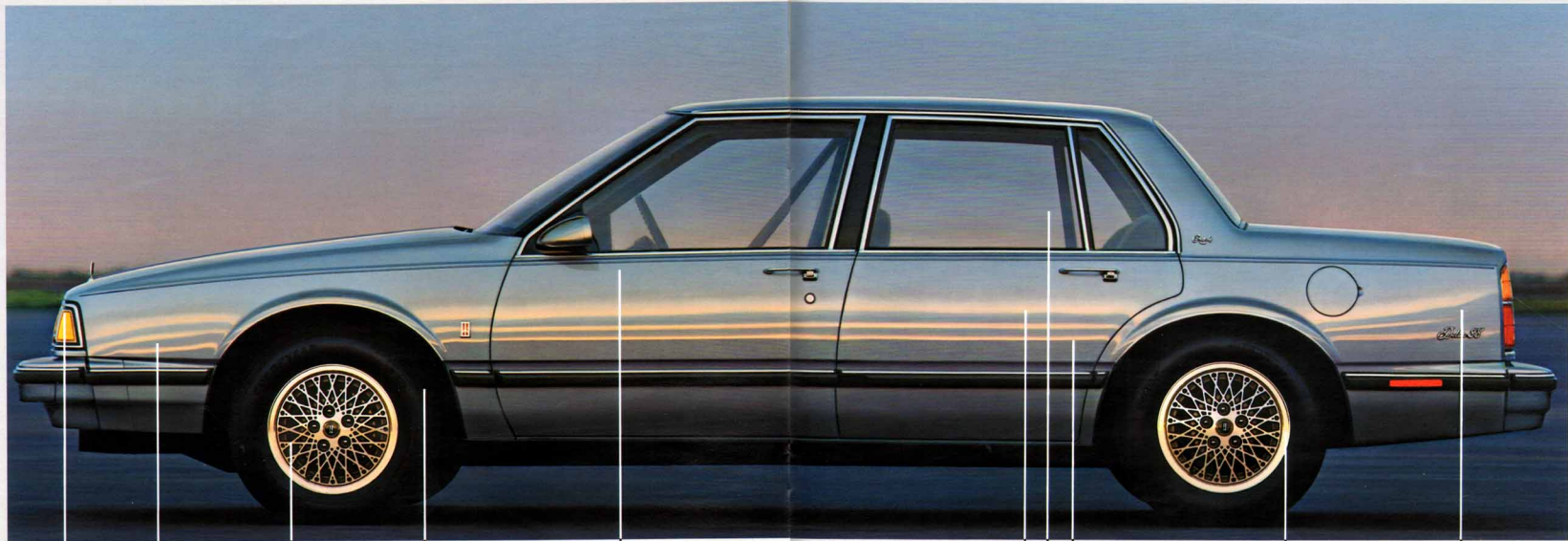

Composite headlights    3.8-liter V6    Front-wheel drive    Power rack-and-pinion steering    4-speed automatic overdrive transmission    Multicoat/high-gloss enamel finish    Tinted glass all around    Two-sided galvanized steel for added protection against corrosion    Four-wheel independent suspension    16.2-cubic-foot trunk

**THIS FAMILY CAR HAS A LOT TO OFFER—  
OUTSIDE, INSIDE, UNDER THE BODY.**

**DELTA 88 ROYALE POWERTRAIN SPECIFICATIONS**

	STANDARD
Displacement	3.8-liter*
Engine	V6
Break HP (rpm)	165 @ 5200
Net torque (lbs. ft.)	215 @ 2000
Bore/Stroke (in.)	3.800/3.400
Compression ratio	8.5 to 1
Fuel management	Electronic Fuel Injection (Sequential port)
Cooling system (qt.)	12.52
<b>DRIVELINE</b>	
Transmission	4-speed automatic
Final drive ratio	1.57 to 1
<b>SUSPENSION/HANDLING</b>	
Front	MacPherson struts
Rear	Semi-independent, stabilizer bar
Front turning diameter curb to curb, left/right (ft.)	39.7/39.1
Trailer towing capacity (lbs.†)	2000

\*3.8 SPI 3800 V6 optional at no extra cost. †Recommended maximum capacity when properly equipped. Includes passengers, cargo and equipment.

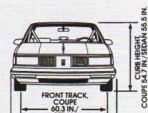
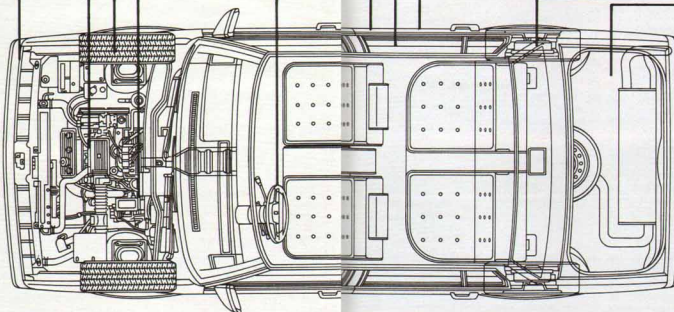

**DELTA 88 ROYALE DIMENSIONS**

BODY/CHASSIS	COUPE	SEDAN
Wheelbase (in.)	110.8	110.8
Track, front/rear (in.)	60.3/59.8	60.3/59.8
Tire size	P205/75R14	P205/75R14
Wheel size	14 x 6	14 x 6
Brake type, front/rear	Disc/Drum	Disc/Drum
Fuel tank (gals.)	18.0	18.0
<b>EXTERIOR</b>		
Length (in.)	196.1	196.1
Width (in.)	72.4	72.4
Height (in.) (curb)	54.7	55.5
Curb weight (lbs.)	3172	3116
	3187R	3214R
<b>INTERIOR</b>		
Headroom, front/rear (in.)	38.1/37.6	38.9/38.3
Legroom, front/rear (in.)	42.4/37.4	42.4/38.1
Shoulder room, front/rear (in.)	59.3/57.8	59.3/59.6
Seating capacity	6	6
Trunk capacity (cu. ft.)	16.2	16.2



## CUSTOM CRUISER

### IT'S A STATION WAGON WITH AN ACCOMMODATING SPLIT PERSONALITY.

On the one hand, Custom Cruiser is one of the largest station wagons you can find anywhere. It's a generously endowed three-seat wagon that carries eight.

With rear seats down, it's a workhorse. It opens up 87.2 cubic feet to carry almost anything from a small snowmobile to a yardful of almost anything that grows.

But Custom Cruiser doesn't stop there. It also provides a roomy, under-floor storage compartment and an available rooftop luggage carrier for extra carrying capacity.

Ah, but when the workday is done, Custom Cruiser takes on the characteristics of a luxury sedan.

You'll relax on full-foam seats encased in rich Baron weave velour, while a computer-selected coil spring suspension and a Firm Ride and Handling package smooth the road below.

Like a luxury sedan, Custom Cruiser provides a wagonful of features as standard equipment: power steering and power front disc brakes, soft-ray tinted windows with power tailgate, and a Delco ETR AM/FM stereo with seek-scan and digital display clock.

The engine is a big, powerful 5.0-liter V8 with 4-speed automatic overdrive transmission, so you're never shortchanged on performance.

Incidentally, Custom Cruiser is ideal for long trips. Equipped for towing, it can haul up to 5,000 pounds\*.

Custom Cruiser. The wagon with a personality that meets the needs of the day or the driver.

\*Includes passengers, cargo and equipment.

CUSTOM CRUISER



#### CUSTOM CRUISER CARGO AREA DIMENSIONS 3-SEAT MODELS

Maximum cargo volume (cu. ft.)	87.2
Floor length from back of front seat to end of floor surface	90.2
Floor length from back of second seat to end of floor surface	55.4
Minimum horizontal distance from top of rear of front seat back to inside of tailgate at belt	83.8
Minimum distance between wheelhouses at floor level	48.2
Rear-end opening width at belt	48.2
Maximum height of rear opening, tailgate open	28.7
Maximum cargo height	29.7

1. Divided bench seat in Dark Claret Baron weave velour.
2. Standard 3-way power tailgate. Fold-down third seat, standard.
3. Available roof rack.
4. Underfloor storage compartment.
5. There's 87.2 cubic feet of cargo room with second seat folded.

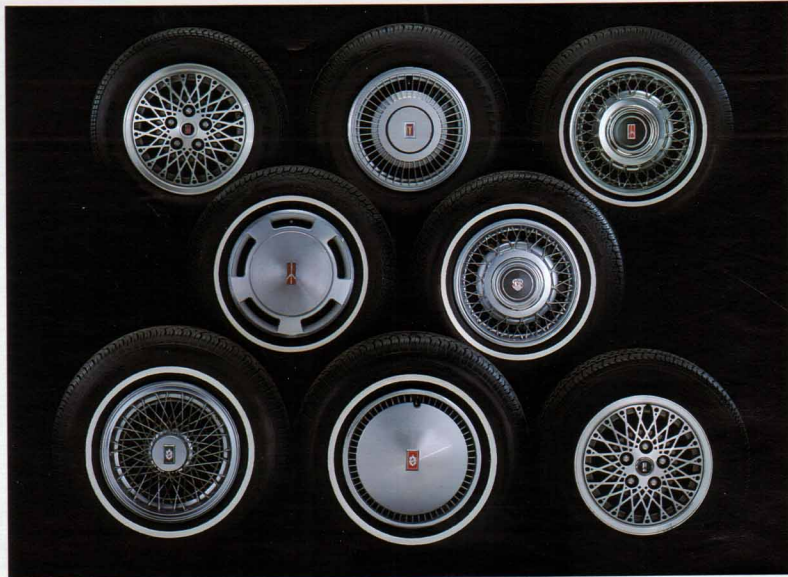

## STANDARD AND AVAILABLE WHEEL TRIMS

### TOP ROW, LEFT TO RIGHT...

Aluminum-Styled Wheel 15" (PH3). Standard on Trofeo, available on Toronado  
 □ Deluxe Wheel Disc—Standard on Toronado, not available on Trofeo □ Simulated Wire Wheel Disc with Lock (N91). Available on all Delta 88 models.

### MIDDLE ROW, LEFT TO RIGHT...

□ Deluxe Wheel Disc. Standard on all Delta 88 and Ninety-Eight Regency models  
 □ Simulated Wire Wheel Disc (N91). Standard on Ninety-Eight Regency Brougham, available on Regency.

### BOTTOM ROW, LEFT TO RIGHT...

Simulated Wire Wheel Disc with Lock (N95). Available on Custom Cruiser  
 □ Deluxe Wheel Disc. Standard on Custom Cruiser □ Aluminum-Styled Wheel (PH3). Available on all Delta 88 and Ninety-Eight Regency models.

## DELCO SOUND SPECIALIST RADIOS

	Delta 88 Royale	Custom Cruiser	Ninety-Eight Regency	Toronado
Radio, Delco ETR AM/FM Stereo with Seek-Scan and Digital Display Clock—includes Dual Rear Speakers with Extended Range* and Fixed Mast Antenna	S	S	S	
Radio, Delco ETR AM/FM Stereo with Seek-Scan, Auto Reverse Cassette with Music Search and Digital Display Clock—includes Dimensional Sound Speaker System				S
UM6 Radio, Delco ETR AM/FM Stereo with Seek-Scan, Auto-Reverse Cassette and Digital Display Clock	A	A	A	
UTO Radio, Delco/Bose Music System, ETR AM Stereo/FM Stereo with Seek-Scan, Auto-Reverse Cassette with Music Search and Digital Display Clock—includes Delco/Bose Speaker System				A
UX1 Radio, Delco ETR AM Stereo/FM Stereo with Seek-Scan, Auto-Reverse Cassette with Music Search, Graphic Equalizer and Digital Display Clock	A	A	A	A
UUB Radio, Delco/Bose Music System, ETR AM/FM Stereo with Seek-Scan, Auto-Reverse Cassette with Music Search and Digital Display Clock—includes Delco/Bose Speaker System			A	

S—Standard equipment A—Available equipment \*—Receiver C-Quam™ AM stereo broadcasts. Most AM stereo stations on the country broadcast in C-Quam™ but some do not. Check with your local stations for compatibility in your area. C-Quam™ is a registered trademark of Motorola, Inc. †Referenced Frank Spangler's Cruise.

## AFFORDABLE NEW OPTION PACKAGES TO PERSONALIZE YOUR OLDS.

DELTA 88 ROYALE/CUSTOM CRUISER OPTION PACKAGES (All Orders must include only ONE Option Package)	ROYALE						ROYALE BROUGHAM						CUSTOM CRUISER					
	1SA	1SB	1SC	1SD	1SE	1SF	1SA	1SB	1SC	1SD	1SE	1SF	1SA	1SB	1SC	1SD	1SE	1SF
<b>C04 Wiper System, Pulse</b>	*	*	*	*	*	*	*	*	*	*	*	*	*	*	*	*	*	*
<b>K34 Cruise Control</b> , Electronic with Resume and Acceleration features	*	*	*	*	*	*	*	*	*	*	*	*	*	*	*	*	*	*
<b>N33 Steering Wheel, Tilt-Away</b>	*	*	*	*	*	*	*	*	*	*	*	*	*	*	*	*	*	*
<b>AM6 Seat</b> , 35-45° Divided Bench Front with Dual Controls	*	*	*	*	*	*	*	*	*	*	*	*	*	*	*	*	*	*
<b>T90 Convenience Group</b> , includes Under-Hood and Trunk Lamps, Visor Vanity Mirror and Chime Tones	*	*	*	*	*	*	*	*	*	*	*	*	*	*	*	*	*	*
<b>AU3 Door Locks, Power</b>	*	*	*	*	*	*	*	*	*	*	*	*	*	*	*	*	*	*
<b>A31 Windows, Power Side</b>	*	*	*	*	*	*	*	*	*	*	*	*	*	*	*	*	*	*
<b>B34 Floor Mats, Auxiliary Front Carpet</b>	*	*	*	*	*	*	*	*	*	*	*	*	*	*	*	*	*	*
<b>B35 Floor Mats, Auxiliary Rear Carpet</b>	*	*	*	*	*	*	*	*	*	*	*	*	*	*	*	*	*	*
<b>B93 Moldings, Door-Edge Guard—Bright</b>	*	*	*	*	*	*	*	*	*	*	*	*	*	*	*	*	*	*
<b>A62 Seat Adjuster, 6-Way Power, Divided Bench Seat—Driver Side</b> (Available only with Divided Bench Seat AM6 on Royale models)	*	*	*	*	*	*	*	*	*	*	*	*	*	*	*	*	*	*
<b>A16 Reclining Seat Back, Passenger Side—Manual</b>	*	*	*	*	*	*	*	*	*	*	*	*	*	*	*	*	*	*
<b>U72 Antenna, Power Front Fender</b>	*	*	*	*	*	*	*	*	*	*	*	*	*	*	*	*	*	*
<b>A90 Trunk-Lid Lock Release, Power</b>	*	*	*	*	*	*	*	*	*	*	*	*	*	*	*	*	*	*
<b>DA0 Armrest, Front Seat Storage</b>	*	*	*	*	*	*	*	*	*	*	*	*	*	*	*	*	*	*
<b>D68 Mirrors, Color-Coordinated Outside—Remote Control, Driver and Passenger Side</b>	*	*	*	*	*	*	*	*	*	*	*	*	*	*	*	*	*	*
<b>Y67 Reminder Package</b> , includes indicators for Low Fuel, Low Coolant, Low Oil Pressure, High Engine Temperature and Brake Warning	*	*	*	*	*	*	*	*	*	*	*	*	*	*	*	*	*	*
<b>C85 Air Conditioner, Electronic Comfort Control</b>	*	*	*	*	*	*	*	*	*	*	*	*	*	*	*	*	*	*
<b>C93 Lamps, Opera Exterior</b>	*	*	*	*	*	*	*	*	*	*	*	*	*	*	*	*	*	*
<b>C97 Illumination Package</b> , Front Door Locks and Interior	*	*	*	*	*	*	*	*	*	*	*	*	*	*	*	*	*	*
<b>D67 Mirrors, Color-Coordinated, Electrically Operated, Outside—Driver and Passenger Side</b>	*	*	*	*	*	*	*	*	*	*	*	*	*	*	*	*	*	*
<b>T87 Lamps, Front Fender Cornering</b>	*	*	*	*	*	*	*	*	*	*	*	*	*	*	*	*	*	*
<b>Z02 Driver Convenience Package</b> , includes Wiper System, Pulse, Cruise Control, Electronic with Resume and Acceleration features, Steering Wheel, Tilt-Away	*	*	*	*	*	*	*	*	*	*	*	*	*	*	*	*	*	*
<b>V55 Luggage Carrier, Rooftop—Chrome—includes Rear Window Air Deflector</b>	*	*	*	*	*	*	*	*	*	*	*	*	*	*	*	*	*	*
<b>BX2 Moldings, Lower Body Side</b>	*	*	*	*	*	*	*	*	*	*	*	*	*	*	*	*	*	*
<b>N91 Wheel Discs, Simulated Wire with Lock</b>	*	*	*	*	*	*	*	*	*	*	*	*	*	*	*	*	*	*
<b>UM6 Radio, Delco ETR AM/FM Stereo with Seek-Scan, Auto-Reverse Cassette and Digital Display Clock—includes Dual Rear Speakers</b>	*	*	*	*	*	*	*	*	*	*	*	*	*	*	*	*	*	*
<b>C95 Lamp, Combination Dome and Dual Lens Reading</b>	*	*	*	*	*	*	*	*	*	*	*	*	*	*	*	*	*	*
<b>D62 Mirrors, Chrome, Electrically Operated, Outside—Driver and Passenger Side</b>	*	*	*	*	*	*	*	*	*	*	*	*	*	*	*	*	*	*
<b>U46 Monitor, Exterior Lamps, Front and Rear</b>	*	*	*	*	*	*	*	*	*	*	*	*	*	*	*	*	*	*
<b>NINETY-EIGHT REGENCY OPTION PACKAGES</b> (All Orders must include only ONE Option Package)																		
	REGENCY						REGENCY BROUGHAM											
	1SA	1SB	1SC	1SD	1SE	1SF	1SA	1SB	1SC	1SD	1SE	1SA	1SB	1SC	1SD	1SE	1SF	
<b>B84 Moldings, Body Side, Bright Stainless with Black Edges</b>	*	*	*	*	*	*	*	*	*	*	*	*	*	*	*	*	*	
<b>C04 Wiper System, Pulse</b>	*	*	*	*	*	*	*	*	*	*	*	*	*	*	*	*	*	
<b>K34 Cruise Control</b> , Electronic with Resume and Acceleration features	*	*	*	*	*	*	*	*	*	*	*	*	*	*	*	*	*	
<b>N33 Steering Wheel, Tilt-Away</b>	*	*	*	*	*	*	*	*	*	*	*	*	*	*	*	*	*	
<b>A90 Trunk-Lid Lock Release, Power</b>	*	*	*	*	*	*	*	*	*	*	*	*	*	*	*	*	*	
<b>U72 Antenna, Power Front Fender</b>	*	*	*	*	*	*	*	*	*	*	*	*	*	*	*	*	*	
<b>A16 Reclining Seat Back, Passenger Side—Manual</b>	*	*	*	*	*	*	*	*	*	*	*	*	*	*	*	*	*	
<b>B34 Floor Mats, Auxiliary Front Carpet</b>	*	*	*	*	*	*	*	*	*	*	*	*	*	*	*	*	*	
<b>B35 Floor Mats, Auxiliary Rear Carpet</b>	*	*	*	*	*	*	*	*	*	*	*	*	*	*	*	*	*	
<b>B93 Moldings, Door-Edge Guard—Bright</b>	*	*	*	*	*	*	*	*	*	*	*	*	*	*	*	*	*	
<b>C85 Air Conditioner, Electronic Comfort Control</b>	*	*	*	*	*	*	*	*	*	*	*	*	*	*	*	*	*	
<b>D64 Mirror, Illuminated Visor Vanity—Passenger Side</b>	*	*	*	*	*	*	*	*	*	*	*	*	*	*	*	*	*	
<b>D74 Mirror, Illuminated Visor Vanity—Driver Side</b>	*	*	*	*	*	*	*	*	*	*	*	*	*	*	*	*	*	
<b>N91 Wheel Discs, Simulated Wire with Lock 14"</b>	*	*	*	*	*	*	*	*	*	*	*	*	*	*	*	*	*	
<b>UM6 Radio, Delco ETR AM/FM Stereo with Seek-Scan, Auto-Reverse Cassette and Digital Display Clock</b>	*	*	*	*	*	*	*	*	*	*	*	*	*	*	*	*	*	
<b>DA0 Armrest, Front Seat Storage</b>	*	*	*	*	*	*	*	*	*	*	*	*	*	*	*	*	*	
<b>T87 Lamps, Front Fender Cornering</b>	*	*	*	*	*	*	*	*	*	*	*	*	*	*	*	*	*	
<b>Y67 Reminder Package</b> , includes indicators for Low Fuel, Low Washer Fluid and Headlamp-On. Also includes audible alarms for Low Fuel, Engine Temperature, Brake Pressure, Low Oil Pressure	*	*	*	*	*	*	*	*	*	*	*	*	*	*	*	*	*	
<b>C97 Illumination Package</b> , Front Door Locks and Interior	*	*	*	*	*	*	*	*	*	*	*	*	*	*	*	*	*	
<b>D67 Mirrors, Color-Coordinated Electrically Operated, Outside—Driver and Passenger Side</b>	*	*	*	*	*	*	*	*	*	*	*	*	*	*	*	*	*	
<b>TORONADO/TROFEO OPTION PACKAGES</b> (All Orders must include only ONE Option Package)																		
	TORONADO/TROFEO																	
	1SA	1SB	1SC	1SD	1SE	1SF												
<b>B34 Floor Mats, Auxiliary Front Carpet</b>	*	*	*	*	*	*												
<b>B35 Floor Mats, Auxiliary Rear Carpet</b>	*	*	*	*	*	*												
<b>B84 Moldings, Body Side—Color-Coordinated</b>	*	*	*	*	*	*												
<b>B93 Moldings, Door-Edge Guard—Color-Coordinated</b>	*	*	*	*	*	*												
<b>C96 Lamps, Interior Upper Quarter Courtesy and Single Lens Reading</b>	*	*	*	*	*	*												
<b>C97 Illumination Package</b> , Front Door Locks and Interior	*	*	*	*	*	*												
<b>D74 Mirror, Illuminated Visor Vanity—Driver Side</b>	*	*	*	*	*	*												
<b>D64 Mirror, Illuminated Visor Vanity—Passenger Side</b>	*	*	*	*	*	*												
<b>T82 Twilight Sentinel</b>	*	*	*	*	*	*												
<b>AU4 Door Locks, Automatic</b>	*	*	*	*	*	*												
<b>A91 Trunk-Lid Pull Down, Power</b>	*	*	*	*	*	*												
<b>N08 Lock, Electric Remote Control, Fuel Filler Door</b>	*	*	*	*	*	*												

**STANDARD AND AVAILABLE EQUIPMENT**

**POWERTRAIN**

<b>K05 Heater, Engine Block</b>	A	A	A	A	A	A	A
<b>L63 Engine, 3.8-liter V6 with Sequential Port Fuel Injection</b>	S	S					
<b>LN3 Engine, 3.8 SFI 3800 V6 (Sequential Port Fuel Injection)</b>	AH	AH		S	S	S	S
<b>LV2 Engine, 5.0-liter V6, 4-cyl.</b>	S	S	S	S	S	S	S
<b>MX0 Transmission, Automatic with Overdrive</b>	S	S	S	S	S	S	S

**CHASSIS**

<b>Battery, Freedom</b>	S	S	S	S	S		
<b>Battery, Freedom High-Capacity</b>	S	S	S	S	S	S	S
<b>Brakes, Power Four-Wheel Disc</b>	S	S	S	S	S	S	S
<b>Brakes, Power Front Disc and Rear Drum</b>	S	S	S	S	S	S	S
<b>Delcotron</b>	S	S	S	S	S	S	S
<b>Ignition System, High Energy</b>	S	S	S	S	S	S	S

**Level II Firm Ride and Handling Suspension System, includes Firm Ride Front and Rear Shock Absorbers, Higher Rate Front and Rear Springs, Larger Front Stabilizer Bar, Rear Stabilizer Bar**

<b>Steering, Power Rack-and-Pinion</b>	S	S	S	S	S	S	S
<b>Suspension System, Four-Wheel fully independent with MacPherson Front Struts, coil springs of rear</b>	S	S	S	S	S	S	S
<b>Suspension System, Four-Wheel fully independent with MacPherson Front Struts, coil springs of rear (Electronic Load Leveling on Brougham)</b>	S	S	S	S	S	S	S
<b>Suspension System, independent front with coil springs and stabilizer bar plus coil springs of rear</b>	S	S	S	S	S	S	S
<b>Suspension System, MacPherson Front Struts with Transflex Independent Rear, plus Automatic Leveling System</b>	S	S	S	S	S	S	S
<b>Suspension System, Touring Car Ride and Handling with MacPherson Front Strut with Transflex Rear, plus Automatic Leveling System</b>	S	S	S	S	S	S	S

**FE2 Level II Load-Carrying Suspension System, includes Firm Ride Front and Rear Shock Absorbers, Higher Rate Front and Rear Springs, Larger Front Stabilizer Bar and Rear Stabilizer Bar, plus Leveling System, Automatic Electric**

**FE2 Level II Load-Carrying Suspension System, includes Higher Control Front and Rear Struts, Higher Rate Front and Rear Springs, Larger Front Stabilizer Bar, Rear Stabilizer Bar**

**FE2 Level II Load-Carrying Suspension System, includes Higher Rate Front and Rear Springs, Higher Control Front and Rear Struts, Larger Diameter Front Stabilizer Bar, plus Rear Stabilizer Bar**

**FE3 Level III Touring Car Ride and Handling Suspension System, consists of special components and special steering gear, plus Steering Wheel, Leather-Wrapped Sport, Wheels, Aluminum Styled 15" (PH3) and Tires, P215/65R15 Performance Steel-Belted Radial-Ply, Blackwall—All-Season; 2.97 Ratio Trans axle (F79) includes V08.**

**FE3 Level III Touring Car Ride and Handling Suspension System, consists of special suspension components, special steering gear, plus Steering Wheel, Leather-Wrapped Sport, Leveling System, Automatic Electric, Wheels, Aluminum Styled 15" (PH3) and Tires, P215/65R15 Performance Steel-Belted Radial-Ply, Blackwall and 2.97 Ratio Trans axle (F79) includes V08.**

**FE3 Level III Touring Car Ride and Handling Suspension System, consists of special suspension components, special steering gear, plus Steering Wheel, Leather-Wrapped Sport, Leveling System, Automatic Electric, Wheels, Aluminum Styled 15" (PH3) and Tires, P215/65R15 Performance Steel-Belted Radial-Ply, Blackwall—All-Season.**

**FE3 Level III Touring Car Ride and Handling Suspension System, consists of special suspension components, special steering gear, plus Steering Wheel, Leather-Wrapped Sport, Leveling System, Automatic Electric, Wheels, Aluminum Styled 15" (PH3) and Tires, P215/65R15 Performance Steel-Belted Radial-Ply, Blackwall—All-Season.**

**FE3 Level III Touring Car Ride and Handling Suspension System, consists of special suspension components, special steering gear, plus Steering Wheel, Leather-Wrapped Sport, Leveling System, Automatic Electric, Wheels, Aluminum Styled 15" (PH3) and Tires, P215/65R15 Performance Steel-Belted Radial-Ply, White Stripe—All-Season.**

**FE3 Level III Touring Car Ride and Handling Suspension System, consists of special suspension components, special steering gear, plus Steering Wheel, Leather-Wrapped Sport, Leveling System, Automatic Electric, Wheels, Aluminum Styled 15" (PH3) and Tires, P215/65R15 Performance Steel-Belted Radial-Ply, White Stripe—All-Season.**

**FE3 Level III Touring Car Ride and Handling Suspension System, consists of special suspension components, special steering gear, plus Steering Wheel, Leather-Wrapped Sport, Leveling System, Automatic Electric, Wheels, Aluminum Styled 15" (PH3) and Tires, P215/65R15 Performance Steel-Belted Radial-Ply, White Stripe—All-Season.**

<b>Wheels, 14 x 5.5</b>									
<b>Wheels, 15 x 7</b>	S	S	S	S	S	S	S		
<b>V16 Braking System, Anti-Lock</b>	A	A	A	A	A	A	A		
<b>V14 Braking System, Anti-Lock</b>	A	A	A	A	A	A	A		
<b>N91 Wheel Discs, Simulated Wire with Lock</b>	AH	AH	AH	AH	AH	AH	AH		
<b>PH3 Wheels, Aluminum Styled 15" —includes Tires, P205/70R15 Road Steel-Belted Radial-Ply, Blackwall—All-Season</b>	AH	AH	AH	AH	AH	AH	AH		
<b>PH3 Wheels, Aluminum Styled 15" —includes Tires, P205/70R15 Road Steel-Belted Radial-Ply, Blackwall</b>							A		
<b>QJR Tires, P205/75R14 Steel-Belted Radial-Ply, White Stripe</b>	AH	AH	AH	AH	AH	AH	AH		
<b>U89 Wiring Harness, Trailer Electrical—5 Wire</b>							A	A	A
<b>U94 Wiring Harness, Trailer Electrical—7 Wire</b>							A	A	A
<b>V08 Cooling Equipment, High-Capacity—includes Battery System, High Capacity (Delta 88 and Ninety-Eight models), Recommended for trailer towing (Battery system is standard on Toronado models)</b>	A	A	A	A	A	A	A	A	A

**EXTERIOR STYLING**

<b>Bumper Front, includes Amber Park/Turn Lamps</b>	S	S	S	S	S	S	S		
<b>Bumper Guards, Front and Rear</b>	S	S	S	S	S	S	S		
<b>Bumper Impact Strips, Front and Rear</b>	S	S	S	S	S	S	S		
<b>Bumper Top Strips, Front and Rear</b>	S	S	S	S	S	S	S		
<b>Deluxe Trim, Luggage Compartment and Spare Tire Cover</b>	S	S	S	S	S	S	S		
<b>Foglamps, with Switch in Header Panel</b>	S	S	S	S	S	S	S		
<b>Front Fascia, with Extended Air Dam</b>	S	S	S	S	S	S	S		
<b>Grille, Black/Gray with Headlamp Covers</b>	S	S	S	S	S	S	S		
<b>Headlamps, Composite Halogen</b>	S	S	S	S	S	S	S		
<b>Headlamps, Composite Halogen Retractable</b>	S	S	S	S	S	S	S		
<b>Headlamps, Halogen Power Retractable</b>	S	S	S	S	S	S	S		
<b>Headlamps, Tunstun Halogen (High Beams)</b>	S	S	S	S	S	S	S		
<b>Hood Ornament, Lay-Down</b>	S	S	S	S	S	S	S		
<b>Hood Ornament, Stand-Up</b>	S	S	S	S	S	S	S		
<b>Mirrors, Exterior Patch Style—Remote Control, Driver and Passenger Side</b>	S	S	S	S	S	S	S		
<b>Mirrors, Outside—Driver Side, Remote Control—Passenger Side, Manual (Chrome on Custom Cruiser)</b>	S	S	S	S	S	S	S		
<b>Moldings, Bell Revealed and Roof Trim</b>	S	S	S	S	S	S	S		
<b>Moldings, Black, Aero Rocker Panel, Wheel-Opening, Beltline and Quarter Windows</b>	S	S	S	S	S	S	S		
<b>Moldings, Rocker Panel and Wheel Opening</b>	S	S	S	S	S	S	S		
<b>Moldings, Side Window</b>	S	S	S	S	S	S	S		
<b>Moldings, Wheel-Opening and Bell Revealed</b>	S	S	S	S	S	S	S		
<b>Windows, Split-Ray Trimmed (with Power Tailgate on Custom Cruiser)</b>	S	S	S	S	S	S	S		
<b>Windshield Wipers, Recessed Park</b>	A	A	A	A	A	A	A		
<b>AD3 Sunroof, Tinted Glass Removable Panel</b>	A	A	A	A	A	A	A		
<b>B84, B88 Moldings, Body Side</b>	S	S	A	S	A	S	A	A	A
<b>B93 Moldings, Door-Edge Guard—Bright (Color-Coordinated on Toronado Models)</b>	A	A	A	A	A	A	A	A	A
<b>BX2 Moldings, Lower Body Side</b>	A	A	A	A	A	A	A	A	A
<b>BX3 Body Side and Tailgate Paneling, Wood-Grain Vinyl includes Brown Door-Edge Guard Moldings</b>	A	A	A	A	A	A	A	A	A
<b>C00 Roofrack Covering, Full Vinyl (Sedan only)</b>	A	A	A	A	A	A	A	A	A
<b>C03 Lamps, Oper Exterior</b>	A	A	A	A	A	A	A	A	A
<b>C05 Roofrack Covering, Full Vinyl Padded</b>	AH	AH	AH	AH	AH	AH	AH	AH	AH
<b>CF8 Astrorof, Electric Sliding Glass Panel in Gray Trim (Headroom is reduced when Option CF8 is ordered)</b>	A	A	A	A	A	A	A	A	A
<b>D68 Mirrors, Color-Coordinated Outside—Remote Control, Driver and Passenger Side</b>	A	A	A	A	A	A	A	A	A
<b>D90 Accent Strips, Body</b>	A	A	A	A	A	A	A	A	A
<b>D62 Mirrors, Chrome, Electrically Operated, Outside—Driver and Passenger Side</b>	A	A	A	A	A	A	A	A	A
<b>D67 Mirrors, Color-Coordinated, Electrically Operated, Outside—Driver and Passenger Side (Black on Toronado Models)</b>	AH	AH	A	A	A	S	S	S	S
<b>DK2 Mirrors, Black, Electrically Operated Outside—Driver and Passenger Side, Driver Side has Electric Defog</b>								A	A
<b>T87 Lamps, Front Fender Covering</b>	AH	AH	AH	AH	AH	AH	AH	AH	AH

**STANDARD AND AVAILABLE EQUIPMENT**

**EXTERIOR STYLING (Con't)**

<b>V17 Paint, Glamour Metallic Colors—83 Medium Sapphire Blue and 95 Light Antique</b>	A	A	A	A	A	A	A
--	---	---	---	---	---	---	---

**INTERIOR FEATURES**

<b>Armrest, Center Front and Rear</b>	S	S	S	S	S	S	S
<b>Armrest, Front and Rear</b>	S	S	S	S	S	S	S
<b>Armrest, Front Seat Center</b>	S	S	S	S	S	S	S
<b>Ashtrays, Instrument Panel and Dual Rear</b>	S	S	S	S	S	S	S
<b>Ashtrays, Instrument Panel and Rear</b>	S	S	S	S	S	S	S
<b>Assist Handle, Passenger Side</b>	S	S	S	S	S	S	S
<b>Cigar Lighter</b>	S	S	S	S	S	S	S
<b>Cigar Lighters, Instrument Panel and Dual Rear</b>	S	S	S	S	S	S	S
<b>Convenience Group, includes Lamps, Visor Vanity Mirror</b>	S	S	S	S	S	S	S
<b>Defoggers, Side Window</b>	S	S	S	S	S	S	S
<b>Door Handles, Black w/Black Lock Cylinders</b>	S	S	S	S	S	S	S
<b>Floor Carpeting, Wall to Wall, Cut-Pile with Carpeted Lower Door Panels (and Cargo Area—Cruiser)</b>	S	S	S	S	S	S	S
<b>Header Panel Storage Unit</b>	S	S	S	S	S	S	S
<b>Hood Release, Interior Operated</b>	S	S	S	S	S	S	S
<b>Instrument Panel Electronic Gauge Cluster, with Tachometer and Reminder Package (Black Accents on Cluster and Console Trim Plate on Torneo)</b>	S	S	S	S	S	S	S
<b>Instrument Panel Trim, brushed Teal Color-Coordinated to Individual Interiors</b>	S	S	S	S	S	S	S
<b>Instrument Panel Trim, Regency Walnut Grain (Simulated on Custom Cruiser)</b>	S	S	S	S	S	S	S
<b>Lamp, Slip—High-Center-Mounted</b>	S	S	S	S	S	S	S
<b>Lamps, Courtesy Instrument Panel, Door Panels and Header Panel Reading, Sail Panel Courtesy (Sail Panel Courtesy/Reading on Torneo)</b>	S	S	S	S	S	S	S
<b>Lamps, Courtesy Warning Door</b>	S	S	S	S	S	S	S
<b>Lamps, Dome, Instrument Panel Ashtray, Courtesy, Glove Box</b>	S	S	S	S	S	S	S
<b>Lamps, Instrument Panel Ashtray, Courtesy, Glove Box and Header Panel Reading</b>	S	S	S	S	S	S	S
<b>Lamps, Instrument Panel, Courtesy and Central Dome</b>	S	S	S	S	S	S	S
<b>Lamp Switches, Automatic Interior</b>	S	S	S	S	S	S	S
<b>Mirror, Inside, Day/Night (Mirrors on Torneo and Digital Display Clock—includes Dual Rear Speakers and Fixed Mast Antenna)</b>	S	S	S	S	S	S	S
<b>Radio, Delco ETR AM/FM Stereo with Seek-Scan and Digital Display Clock—includes Dual Rear Speakers and Fixed Mast Antenna</b>	S	S	S	S	S	S	S
<b>Radio, Delco ETR AM/FM Stereo with Seek-Scan and Digital Display Clock—includes Dual Rear Speakers with Extended Range and Fixed Mast Antenna</b>	S	S	S	S	S	S	S
<b>Radio, Delco ETR AM/FM Stereo with Seek-Scan, Auto-Reverse Cassette with Music Search, and Digital Display Clock—includes Dimensional Sound Speaker System and Rear-Fender Power Antenna</b>	S	S	S	S	S	S	S
<b>Rear Storage Compartment Lock</b>	S	S	S	S	S	S	S
<b>Spare Tire Protector</b>	S	S	S	S	S	S	S
<b>Steering Wheel, Deluxe Proportionate</b>	S	S	S	S	S	S	S
<b>Steering Wheel, Deluxe with Tilt-Away features</b>	S	S	S	S	S	S	S
<b>Steering Wheel, Leather-Wrapped Sport with Tilt-Away features</b>	S	S	S	S	S	S	S
<b>Tip Odometer</b>	S	S	S	S	S	S	S
<b>Turn-Signal-On Reminder Chime</b>	S	S	S	S	S	S	S
<b>UX4 Door Locks, Automatic</b>	A	A	A	A	A	A	A
<b>CS8 Lamps, Sail Panel Reading</b>	AH	AH	AH	AH	AH	AH	AH
<b>T99 Convenience Group, includes Under-Hood and Funks Lamps, Visor Vanity Mirror and Chime Tones</b>	A	S	S	S	S	S	S
<b>UM6 Radio, Delco ETR AM/FM Stereo with Seek-Scan, Auto-Reverse Cassette and Digital Display Clock</b>	A	A	A	A	A	A	A
<b>UTO Radio, Delco/Bose Music System, ETR AM Stereo/FM Stereo with Seek-Scan, Auto-Reverse Cassette with Music Search and Digital Display Clock—includes Delco/Bose Speaker System</b>	A	A	A	A	A	A	A
<b>U18 Radio, Delco/Bose Music System, ETR AM/FM Stereo with Seek-Scan, Auto-Reverse Cassette with Music Search and Digital Display Clock—includes Delco/Bose Speaker System</b>	A	A	A	A	A	A	A

<b>UX1 Radio, Delco ETR AM Stereo/FM Stereo with Seek-Scan, Auto-Reverse Cassette with Music Search, Graphic Equalizer and Digital Display Clock</b>	A	A	A	A	A	A	A
--	---	---	---	---	---	---	---

**SEATING AND TRIMS**

<b>Safety Belts, Automatic, Color-Keyed to Interior Trim</b>	S	S	S	S	S	S	S
<b>Safety Belts, Deluxe—Color-Coordinated with Individual Interiors</b>	S	S	S	S	S	S	S
<b>Safety Belts, Deluxe Front and Rear, Color-Keyed to Interior Trim</b>	S	S	S	S	S	S	S
<b>Seat, Custom Bench Front with Center Armrest</b>	S	S	S	S	S	S	S
<b>Seat, Front Buckets with 6-Way Power Adjuster, Power Recliner with Console-Mounted Switches for Power Back Contour and Power Lumbar features</b>	S	S	S	S	S	S	S
<b>Seat, Rear-Facing Third</b>	S	S	S	S	S	S	S
<b>Seat, 55/45 Divided Bench Front with Center Armrest, Easy-Entry Feature on Passenger Side</b>	S	S	S	S	S	S	S
<b>Seat, 55/45 Divided Bench Front with Dual Controls, Driver Side—6-Way Power, Passenger Side—Manual</b>	S	S	S	S	S	S	S
<b>Seat, 55/45 Divided Bench Front with Individual Controls</b>	S	S	S	S	S	S	S
<b>Seat Back Recliners, Driver and Passenger Side—Manual</b>	S	S	S	S	S	S	S
<b>Seat Cushions, Full Foam—Front and Rear</b>	S	S	S	S	S	S	S
<b>AC1 Seat Adjuster, 6-Way Power, Divided Seat—Passenger Side</b>	AH	AH	AH	AH	AH	AH	AH
<b>AG1 Seat Adjuster, 6-Way Power, Divided Seat—Driver Side</b>	AH	AH	AH	AH	AH	AH	AH
<b>AG2 Seat Adjuster, 6-Way Power, Divided Seat—Passenger Side</b>	AH	AH	AH	AH	AH	AH	AH
<b>AJ3 Restraint System, Front Inflatable, Driver Side</b>	AH	AH	AH	AH	AH	AH	AH
<b>AM6 Seat, 55/45 Divided Front Bench with Dual Controls</b>	A	S	S	S	S	S	S
<b>AR5 Seat, Center Reclining Bucket—includes Console with Floor Shifter</b>	A	A	A	A	A	A	A
<b>AT6 Reclining Seat Back, Passenger Side—Manual</b>	A	A	A	A	A	A	A
<b>WJ7 Trim, Custom Leather in Seating Areas—includes Steering Wheel, Leather-Wrapped Sport (Wheel is standard on Toronado)</b>	AH	AH	AH	AH	AH	AH	AH

**COMFORT/CONVENIENCE FEATURES**

<b>Air Conditioner, Electronic Automatic—Manual Override</b>	S	S	S	S	S	S	S
<b>Air Conditioner, Four-Season</b>	S	S	S	S	S	S	S
<b>Door Pull Handles</b>	S	S	S	S	S	S	S
<b>Headlamp-On Reminder</b>	S	S	S	S	S	S	S
<b>A31 Windows, Power Side</b>	AH	AH	AH	AH	AH	AH	AH
<b>Radio, Delco ETR AM/FM Stereo with Seek-Scan and Digital Display Clock—includes Dual Rear Speakers and Fixed Mast Antenna</b>	AH	AH	AH	AH	AH	AH	AH
<b>AG1 Trunk-Lid Pull Down, Power</b>	AH	AH	AH	AH	AH	AH	AH
<b>AJ3 Door Locks, Power (includes Tailgate Lock Release on Custom Cruiser)</b>	AH	AH	AH	AH	AH	AH	AH
<b>B34 Floor Mats, Auxiliary Front Carpet</b>	AH	AH	AH	AH	AH	AH	AH
<b>B35 Floor Mats, Auxiliary Rear Carpet</b>	AH	AH	AH	AH	AH	AH	AH
<b>C49 Defogger, Electric Rear Window</b>	A	A	A	A	A	A	A
<b>C65 Air Conditioner, Electronic Comfort Control (Manual Override on Torneo)</b>	A	A	A	A	A	A	A
<b>CD4 Wiper System, Pulse</b>	AH	AH	AH	AH	AH	AH	AH
<b>CD5 Lamps, Combination Dome and Dual Lens Reading</b>	AH	AH	AH	AH	AH	AH	AH
<b>CD6 Lamps, Interior Upper Quarter Console and Single Lens Reading</b>	AH	AH	AH	AH	AH	AH	AH
<b>CD7 Illumination Package, Front Door Locks and Interior</b>	AH	AH	AH	AH	AH	AH	AH
<b>D04 Wiper System, Pulse</b>	AH	AH	AH	AH	AH	AH	AH
<b>D64 Mirror, Illuminated Visor Vanity—Passenger Side—includes Lamps, Interior, Front Door Courtesy and Dual Lens Reading on Delta 88 Models</b>	A	A	AH	AH	AH	AH	AH
<b>D74 Mirror, Illuminated Visor Vanity—Driver Side</b>	AH	AH	AH	AH	AH	AH	AH
<b>D40 Armrest, Front Seat Storage</b>	AH	AH	AH	AH	AH	AH	AH
<b>DD8 Mirror, Inside Automatic Day-Night</b>	A	A	A	A	A	A	A
<b>K34 Cruise Control, Electronic with Resume and Acceleration features</b>	A	A	A	A	A		

**STANDARD AND AVAILABLE EQUIPMENT**

**COMFORT/CONVENIENCE FEATURES (Cont')**

	Delta 88 Royale Coupe	Delta 88 Royale Sedan	Delta 88 Royale 2-Seat Wagon	Delta 88 Royale 3-Seat Wagon	Delta 88 Royale 4-Door Sedan	Delta 88 Royale 4-Door Wagon
<b>U14 Cluster, Instrument Panel</b> —includes Voltmeter, Temperature and Oil Pressure gauges	AH	AH	AH	AH	AH	AH
<b>U16 Monitor, Exterior Lamps, Front and Rear</b>	A*	A*				
<b>U51 Information System, Driver</b> —provides digital readout English/metric for Fuel Economy, instantaneous and average Range and Fuel Used, Time and Exposed Time, plus Average Miles-Per-Hour, Date, Estimated Time of Arrival and Total Distance to Destination. Also provides automated service reminders showing Estimated Oil Life remaining before next oil change is required. Digital gauge information for Tachometer, Voltmeter and Coolant Temperature	AH	AH	A	A		
<b>U52 Cluster, Instrument Panel Electronic</b> —includes Multicolor Vacuum Fluorescent Display features, Bar Graph Vehicle Speed, Fuel Level and Engine Temperature, Digital Display of total Odometer, Trip Odometer, Inside/Outside Temperature and Transmission Shift Position, plus English/metric Conversion Switch			AH	AH		
<b>U72/U75 Antenna, Power Front Fender</b>	A*	A*	A*	A*		

S=Standard equipment A=Available equipment \*Also available in an option package. †=Available only when other options are ordered/equipped. See your dealer for details.

**STANDARD EXTERIOR COLORS (Actual color paint chips available. Ask your salesperson.)**

11 White ○	41 Black ● ■
13 Platinum Metallic ●, ■, ▲	52 Copper Beige ○
14 Black Metallic ○	57 Light Beechwood Metallic ○
15 Medium Gray Metallic ○	59 Dark Beechwood Metallic ○
19 Black ○	62 Light Beechwood ●
27 Light Sapphire Blue Metallic ●	67 Dark Antelope Metallic ●
28 Light Sapphire Blue Metallic ○	69 Medium Beechwood ●
29 Dark Sapphire Blue Metallic ●, ■, ▲	72 Medium Garnet Red Metallic ●, ■, ▲
30 Dark Sapphire Blue Metallic ○	75 Medium Garnet Red Metallic ○
40 White ●, ■, ▲	76 Dark Garnet Red Metallic ●, ■, ▲

**AVAILABLE EXTERIOR COLORS**

<b>V16 Glamour Metallic paints</b>	83 Medium Sapphire Blue Glamour Metallic/13 Platinum Metallic ▲
83 Medium Sapphire Blue Glamour Metallic ■	85 Light Antelope Glamour Metallic/76 Dark Antelope ▲
85 Light Antelope Glamour Metallic ■	

**1988 OLDSMOBILE MODEL LINEUP**

<b>VOLUME I</b>	<b>VOLUME II</b>
Toronado Turbo	Delta 88 Royale Coupe
Toronado Coupe	Delta 88 Royale Sedan
Oldsmobile Touring Sedan	Delta 88 Royale 2-Seat Wagon
Ninety-Eight Regency Brougham Sedan	Delta 88 Royale 3-Seat Wagon
Custom Cruiser 3-Seat Wagon	Delta 88 Royale Brougham Sedan

	Delta 88 Royale Coupe	Delta 88 Royale Sedan	Delta 88 Royale 2-Seat Wagon	Delta 88 Royale 3-Seat Wagon	Delta 88 Royale 4-Door Sedan	Delta 88 Royale 4-Door Wagon
<b>U48 Theft Deterrent System</b>						
<b>U19 Telephones, Mobile—Deluxe</b>					AH	A
<b>UW4 Speakers, Dimensional Sound System—6 Speakers</b>					AH	AH S
<b>U12 Telephone, Mobile</b>						AH
<b>V55 Luggage Carrier, Roof-top—Chrome</b> —includes Rear Window Air Deflector				A*		
<b>V58 Luggage Carrier, Deck Lid—Block with Chrome Slats</b> —includes High-Level Stop Lamp		A	A	A	A	
<b>V67 Reminder Package</b> —includes indicators for Low Fuel, Low Coolant, Low Oil Pressure, High Engine Temperature and Brake Warning				A*	A*	A*
<b>V67 Reminder Package</b> —includes indicators for Low Fuel, Low Washer Fluid, and Headlamp-On. Also includes audible alarms for Low Fuel, Engine Temperature, Brake Pressure and Low Oil Pressure					A*	A*
<b>Z02 Driver Convenience Package</b> , includes Water Spray System, Pulse, Cruise Control, Electronic with Resume and Acceleration features and Steering Wheel, Tilt-Away					A*	

S=Standard equipment A=Available equipment \*Also available in an option package. †=Available only when other options are ordered/equipped. See your dealer for details.

79 Burgundy Metallic ○	82 Medium Rosewood ●	87 Dark Antelope Met/85 Light Antelope ▲
82 Medium Rosewood ●	86 Light Antelope Beige ●	72 Medium Garnet Red Met/13 Platinum Met. ▲
86 Light Antelope Beige ●	87 Medium Gray Metallic ●, ■, ▲	76 Dark Garnet Red Met/13 Platinum Met. ▲
87 Medium Gray Metallic ●, ■, ▲		80 Light Rosewood Met./82 Medium Rosewood Met. ▲
		82 Medium Rosewood Met./13 Platinum Met. ▲
		87 Medium Gray Met./13 Platinum Met. ▲
		87 Medium Gray Met./13 Platinum Met. ▲

**KEY**

● Delta 88 Royale/Royale Brougham	▲ Toronado
○ Custom Cruiser	▲ Toronado Turbo
■ Ninety-Eight Regency/Regency Brougham	Met=Metallc

Cutlass Calais St. Sedan	Cutlass Calais Sedan	Cutlass Calais Sedan
Cutlass Calais Coupe	Cutlass Cruiser Brougham 2-Seat Wagon	Cutlass Cruiser 2-Seat Wagon
Cutlass Calais Sedan	Cutlass Supreme Classic Brougham Coupe	Cutlass Supreme Classic Coupe
Cutlass Calais International Series Coupe	Cutlass Supreme Classic Coupe	Cutlass Supreme Classic Coupe
Cutlass Calais International Series Sedan	Cutlass Supreme Classic Coupe	Cutlass Supreme Classic Coupe
Cutlass Calais International Series Sedan	Cutlass Supreme Classic Coupe	Cutlass Supreme Classic Coupe
Cutlass Calais St. Coupe	Cutlass Supreme Classic Coupe	Cutlass Supreme Classic Coupe
Cutlass Calais International Series Coupe	Cutlass Supreme Classic Coupe	Cutlass Supreme Classic Coupe
Cutlass Calais International Series Sedan	Cutlass Supreme Classic Coupe	Cutlass Supreme Classic Coupe
Cutlass Calais St. Coupe	Cutlass Supreme Classic Coupe	Cutlass Supreme Classic Coupe

The 1988 Oldsmobiles are carefully designed and built to resist corrosion, so the application of additional rustproofing is neither

necessary or required. Oldsmobile's confidence in its extensive anti-corrosion protection is reflected in a new vehicle warranty

which includes 6-year/100,000-mile rust-through protection. See your dealer for terms and conditions of the limited warranty.

PRINTED IN USA 8/87

**Important—A word about this catalog:** We have tried to make this catalog as comprehensive and factual as possible, and we hope you find it helpful. However, since the time of printing, some of the information you will find here may have been updated. Also, some of the equipment shown or described throughout this Olds catalog is available at extra cost. Your dealer has details; before ordering, you should be brought up-to-date. The right is reserved to make changes at any time, without notice, in prices, colors, materials, equipment, specifications and models. Check with your Olds dealer for complete information.

**A word about engines:** Oldsmobiles are equipped with engines produced by GM or suppliers to GM worldwide.

**A word about assembly, components and optional equipment in these Oldsmobile products:** The Oldsmobiles described in this catalog are assembled at facilities operated by General Motors or GM of Canada. These vehicles incorporate thousands of different components produced by car groups or various component divisions of General Motors and by various suppliers worldwide to GM. From time to time during the manufacturing process, it may be necessary, in order to meet public demand for particular vehicles or equipment, or to meet federally mandated emissions, safety and fuel economy requirements, or for other reasons, to produce Oldsmobile products with different components or differently

sourced components than initially scheduled. All such components have been approved for use in Oldsmobile products and will provide the quality performance associated with the Oldsmobile name. With respect to extra-cost optional equipment, make certain you specify the type of equipment you desire on your vehicle when ordering it from your dealer. Some options may be unavailable when your car is built. Your dealer receives advice regarding current availability of options. You may ask your dealer for this information. GM also requests your dealer to advise you if the option you ordered is unavailable. We suggest that you verify that your car includes the optional equipment you ordered, or if there are changes, that they are acceptable to you.

**Occupant protection features:** Automatic safety belt system for driver and right front passenger on Delta 88 Royale. Driver side inflatable Restraint (available on Delta 88 Royale Sedan). Manual lap/shoulder safety belts for driver and right front passenger, driver side includes visual and audible warning system on all other models. Manual lap/shoulder safety belts, outboard rear seat positions on Delta 88 and Toronado. Manual lap safety belts, center front/rear seat positions, where applicable. Energy-absorbing steering column. Energy-absorbing instrument panel. Energy-absorbing seat back tops, front. Laminated safety windshield glass. Safety interlocking door latches. Side-guard door

beam. Passenger-guard inside door lock handles. Inertia-locking, folding front seat backs on two-door models. Safety armrests. Head restraints, driver and right front passenger (adjustable).

**Accident avoidance features:** Side marker lights and reflectors. Parking lamps that illuminate with headlamps. Four-way hazard warning flasher. Back-up lights. Center high-mounted stop lamp. Directional signal control with lane change feature. Windshield defroster, washer and multi-speed wipers. Inside rearview mirror. Dual outside viewing mirrors. Brake system with dual master cylinder and warning light. Starter safety switch. Dual action hood latch. Low-glare finish on inside windshield moldings, wiper arms and blades, metallic steering wheel surfaces. Illuminated heater and defroster controls. Tires with built-in tread-wear indicators.

**Theft deterrence features:** Audible reminder for ignition key removal. Theft-deterrent steering column lock. Visible vehicle identification number.

**A word about updated service information:** Oldsmobile regularly sends its dealers useful service bulletins about Oldsmobile products. Oldsmobile monitors product performance in the field. We then prepare bulletins for servicing our product better. Now you can get these bulletins, too. Ask your dealer. To get ordering information, call toll free 1-800-551-4123.

**ALONG WITH YOUR NEW OLDS—WE'LL START YOU OFF WITH A FULL TANK OF GAS, SPECIAL KEYS, A PORTFOLIO OF USEFUL INFORMATION AND A GREAT FEELING OF SATISFACTION.**

This literature has been produced to provide you with as much extensive information as possible about the 1988 Oldsmobiles. If you have any questions or require further information, visit your Oldsmobile dealer. He has voluminous additional information and specifications available for your use.

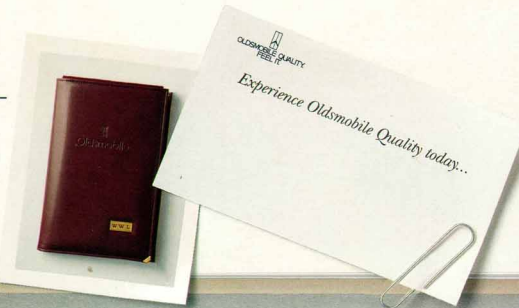



OLDSMOBILE QUALITY.  
FEEL IT.