

the
59 FORD
station wagons

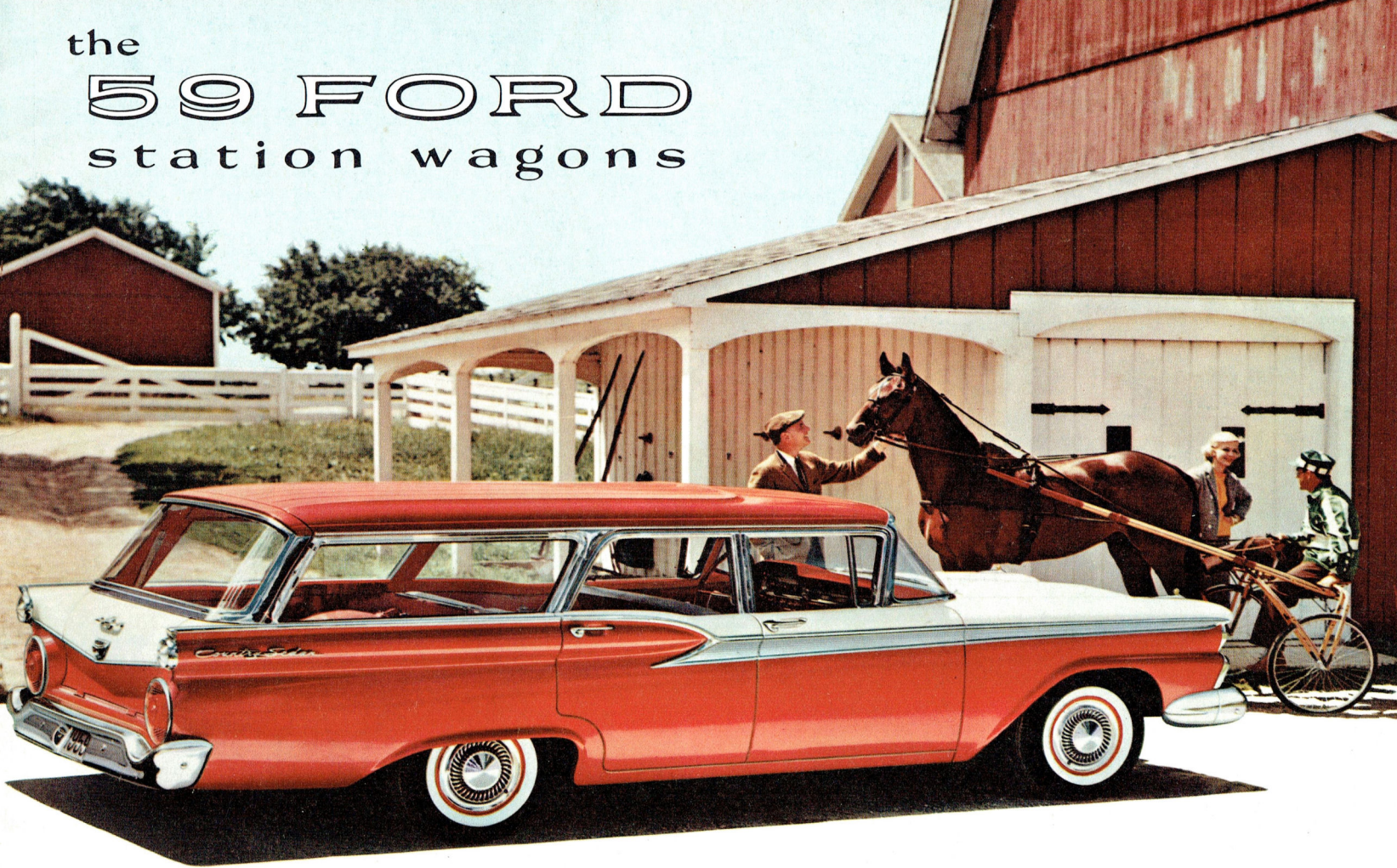

THE WORLD'S MOST BEAUTIFULLY PROPORTIONED CARS

THE NEWEST IN WAGONS FROM AMERICA'S WAGON SPECIALISTS

Here's the fresh new direction in station wagon design: *hardtop styling*. And *how* your neighbors will love it!

For '59 all six of Ford's Station Wagons are bigger . . . over 7 inches longer inside with nearly 5 square feet more loadspace riding on a 2-inch longer wheelbase. They're far easier to load, too, than other wagons in Ford's class. They have a still-larger glass area for full-circle visibility. And thanks to Ford's unique thin-pillar design, you get *hardtop styling* for that wide-open modern look. What's more, Ford is the only manufacturer of the most popular three who knows how to provide comfort and convenience—and still keep *all seats facing forward!*

Ford's standard engines for '59—Six or Thunderbird V-8—are designed to thrive on *regular* gasoline. (You save up to 5¢ over premium gas on every gallon you buy!) New aluminized mufflers will normally last twice as long as conventional types on other wagons. Full-flow oil filtration means an oil change only every 4000 miles. New Diamond Lustre Finish is so durable you won't have to wax it—*ever!* New Tyrex cord tires are tougher, ride cooler, give greater safety. And *all* are *standard* equipment!

But with all their economy . . . all their hardtop styling . . . all their performance . . . you'll be pleasantly surprised to discover that these 1959 Ford wagons are a masterpiece of underpricing!

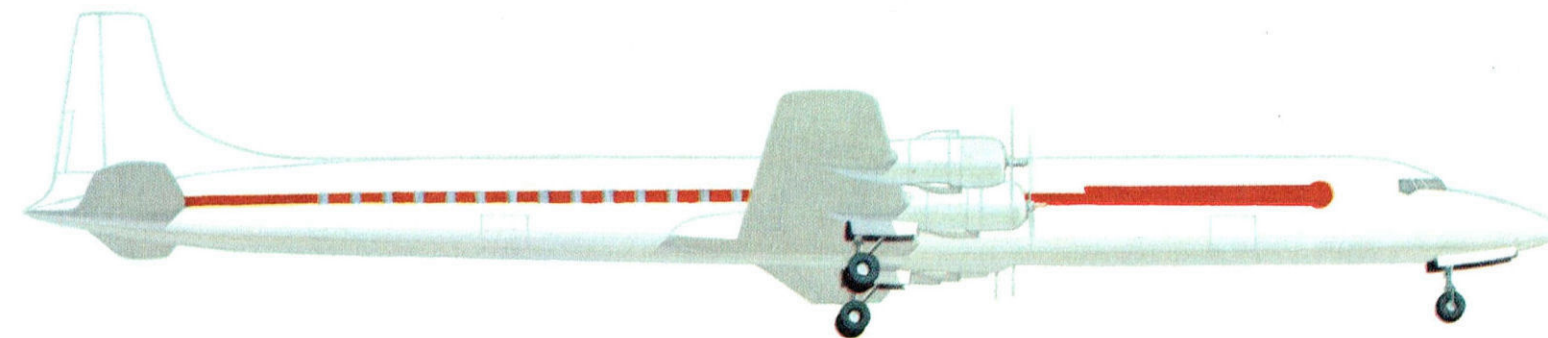

RAVEN BLACK, SINGLE COLOR

THE 9-PASSENGER COUNTRY SQUIRE

Feast your eyes upon this thrilling 1959 version of the most distinctive station wagon in the country . . . in the city, *too*, for that matter! Long and luxurious, this 4-door "Squire" is the only wagon in its field to offer you all-weather paneling that looks like mahogany, wears like steel (which it is)!

And notice, too, how all three seats face comfortably *forward!* There's no "wrong way" third seat to force you to crawl in over the tailgate . . . to blind you with the glare of following headlights . . . or subject you to watching the charge of onrushing traffic.



AWARDED THE GOLD MEDAL of the Comité Français de l'Élégance AT THE BRUSSELS WORLD'S FAIR "Pour proportions exceptionnelles et la ligne élégante"

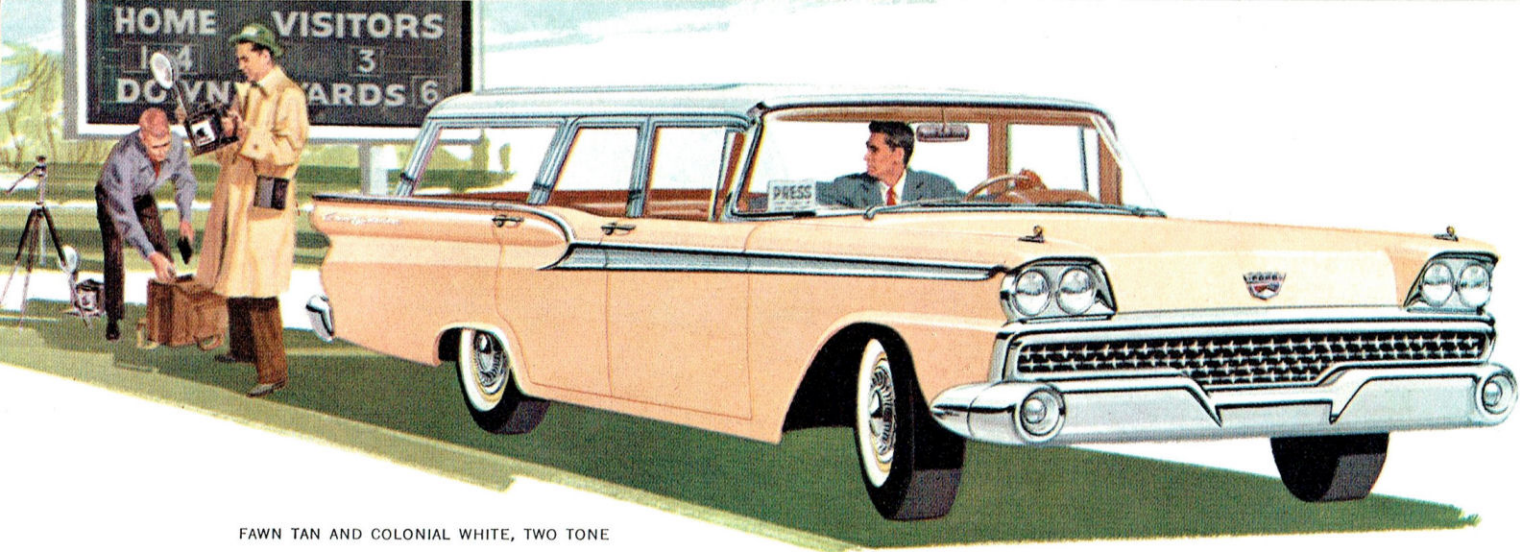

FAWN TAN AND COLONIAL WHITE, TWO TONE

Good impressions are important in business. That's why so many businessmen choose Ford's smart 9-passenger Country Sedan. As do all Ford wagons, it offers you a choice of suspensions: (1) a new, softer regular suspension for normal, all-purpose use . . . (2) a special heavy-duty suspension for wagons used in continuous heavy hauling service. Only Ford offers you this choice of station wagon suspensions! Other superior Ford features include a *fully insulated* roof for greater quiet and heat deflection . . . and *five* roof cross braces for greater top rigidity.



TORCH RED AND COLONIAL WHITE, STYLE TONE

9-PASSENGER COUNTRY SEDAN

You'll get that new Ford feeling in this handsome, 9-passenger Country Sedan with its Thunderbird elegance! This handy 4-door dandy, with over 17% more cargo space, has a new third seat that features *removable* resilient foam cushions on seat and back. These can be quickly stowed at the sides . . . or conveniently used for mattresses or picnic cushions. You've never seen a third seat that's so comfortable . . . so easy to convert into loadspace!



All seats face forward and the whole team goes along in Ford's big, brawny 9-passenger wagons. In fact, only Ford in the entire low-price field can give you three big, *full-width, forward-facing* seats! You ride in regal living-room comfort, too, for *every* seat of every Ford Station Wagon is *foam padded* as standard equipment (except the rear seat in the Ranch Wagons). Compare this with the thin, hard-riding seats found in some other wagons in Ford's field!

Entirely new for '59, this beautifully proportioned instrument panel is Safety Curved for your protection. Controls are recessed, amply lighted and easy to read; colors have been re-styled to harmonize with the new interiors.

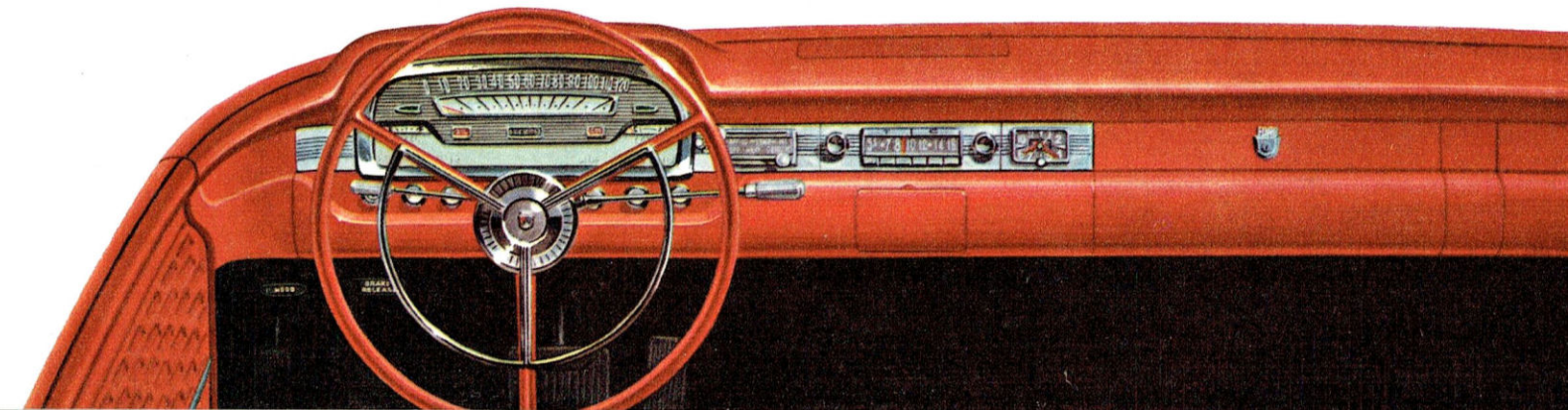

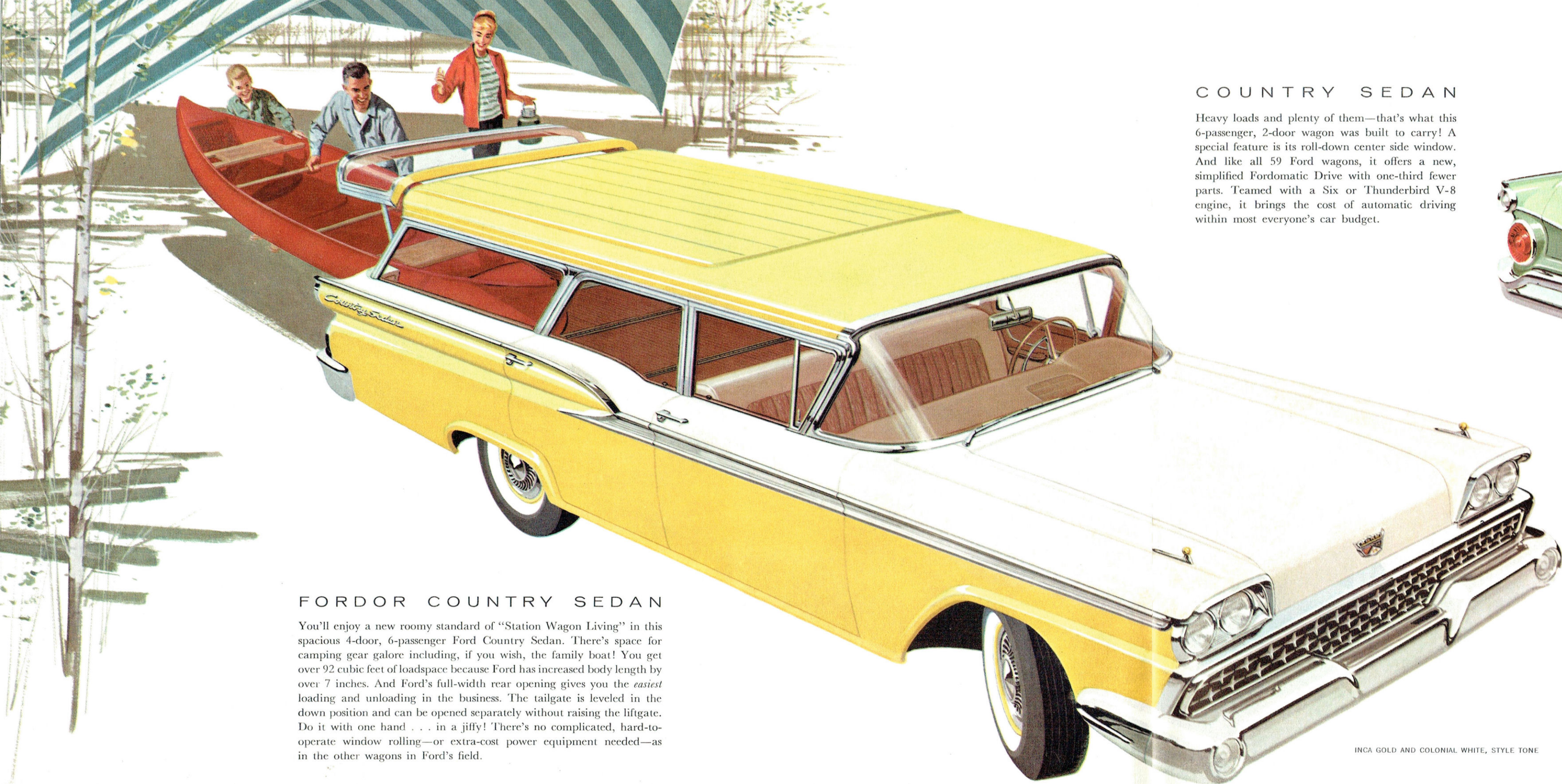

FORDOR COUNTRY SEDAN

You'll enjoy a new roomy standard of "Station Wagon Living" in this spacious 4-door, 6-passenger Ford Country Sedan. There's space for camping gear galore including, if you wish, the family boat! You get over 92 cubic feet of loadspace because Ford has increased body length by over 7 inches. And Ford's full-width rear opening gives you the *easiest* loading and unloading in the business. The tailgate is leveled in the down position and can be opened separately without raising the liftgate. Do it with one hand . . . in a jiffy! There's no complicated, hard-to-operate window rolling—or extra-cost power equipment needed—as in the other wagons in Ford's field.

COUNTRY SEDAN

Heavy loads and plenty of them—that's what this 6-passenger, 2-door wagon was built to carry! A special feature is its roll-down center side window. And like all 59 Ford wagons, it offers a new, simplified Fordomatic Drive with one-third fewer parts. Teamed with a Six or Thunderbird V-8 engine, it brings the cost of automatic driving within most everyone's car budget.



SHERWOOD GREEN AND APRIL GREEN, STYLE TONE

Luxury Lounge Interiors . . . These are the most beautiful interiors Ford has offered in nearly 30 years as the station wagon leader! Harmoniously color-keyed, they feature newly decorated door panels and trim, all-vinyl or woven plastic seat fabrics, as well as all-new "radiant" vinyl bolsters that give a brighter, more spacious effect. They come clean as a whistle with just a wipe . . . as does the smart new basket-weave headlining!

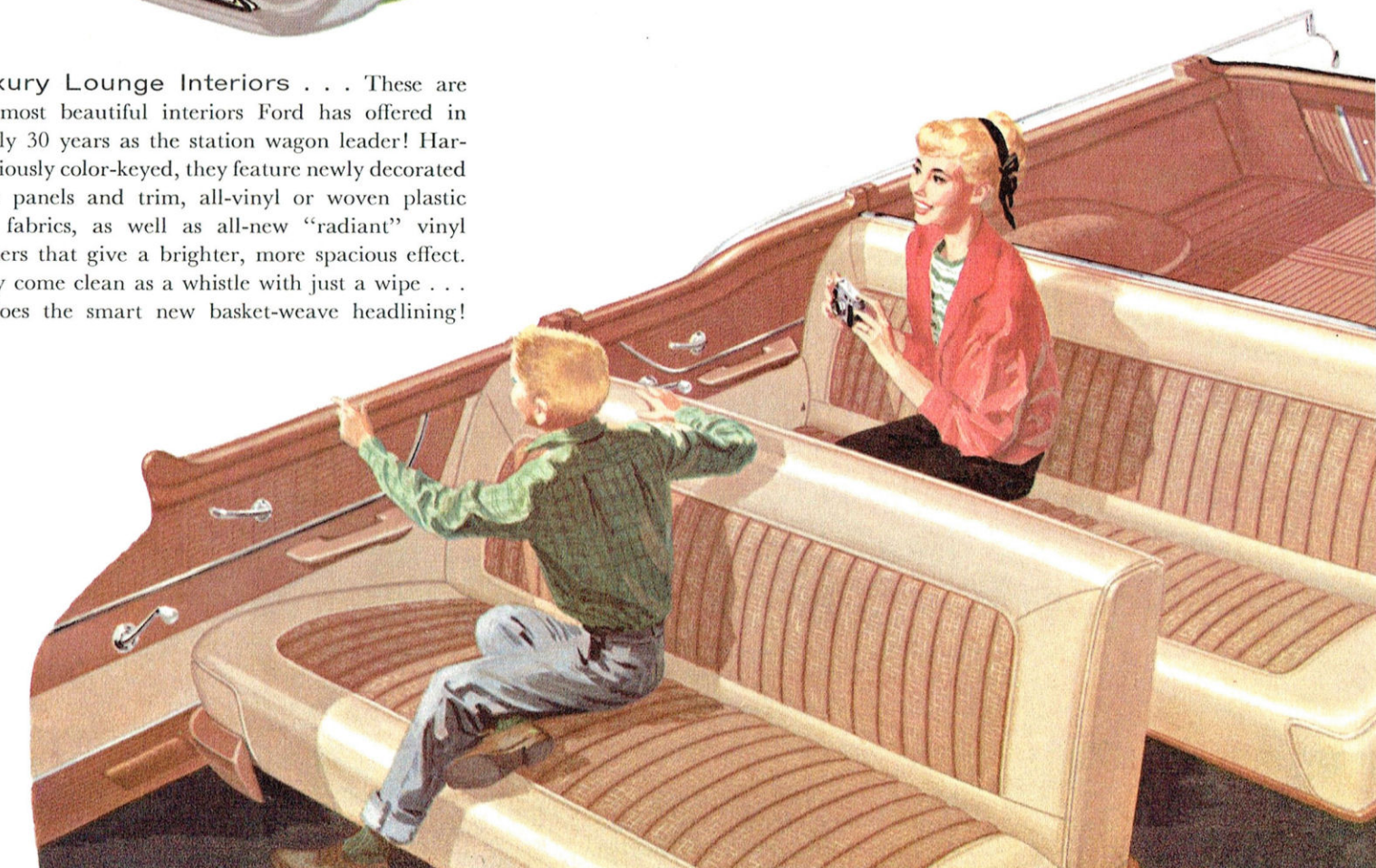

INCA GOLD AND COLONIAL WHITE, STYLE TONE

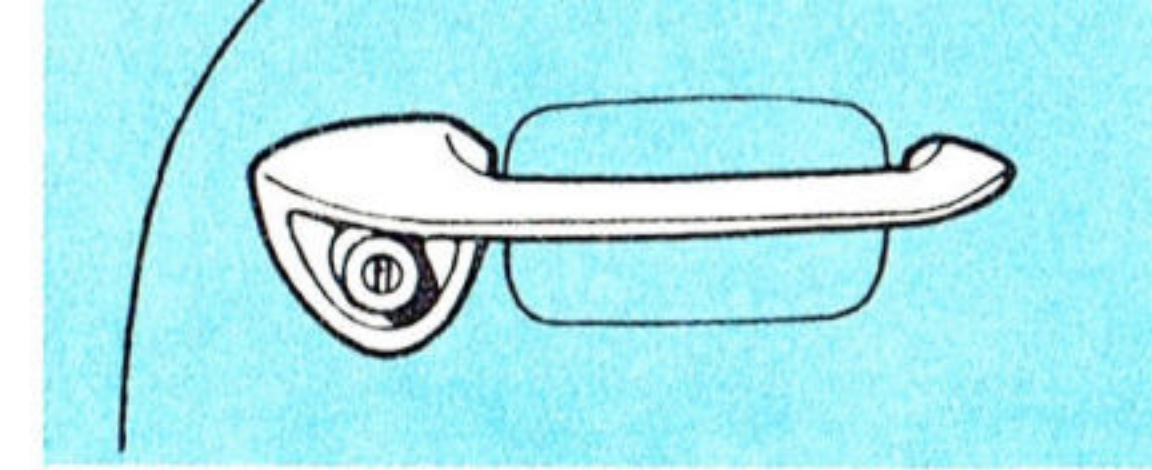

Smart new door handle has the locking cylinder inside the push button for still greater convenience and safety. You no longer have to lift a cover to insert the key.

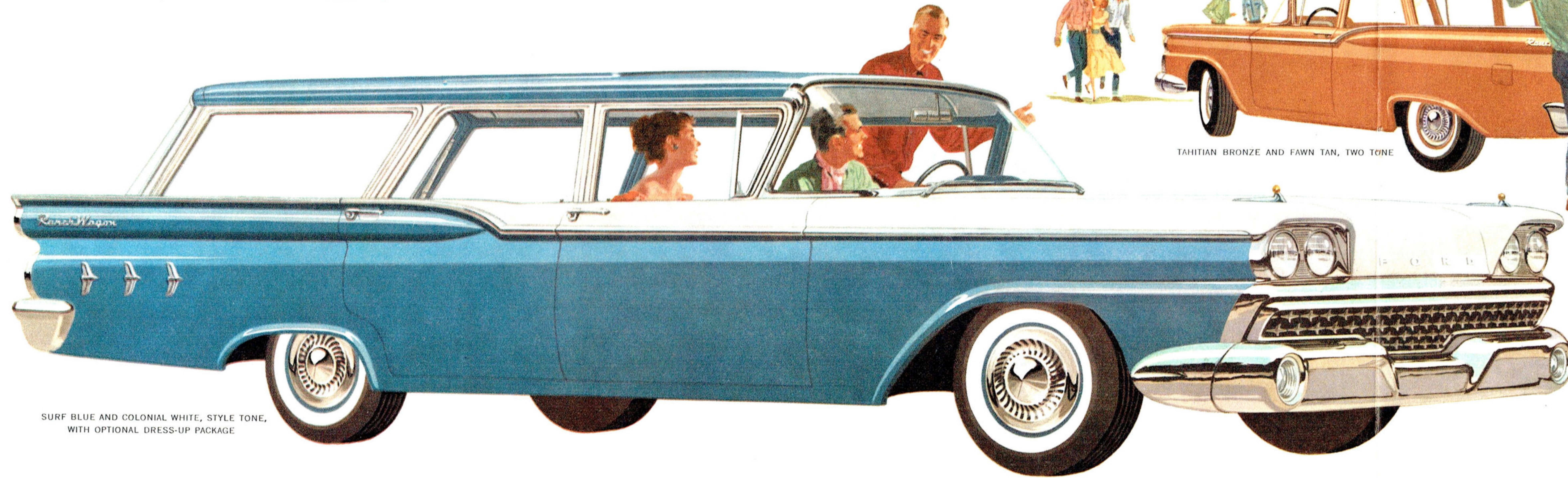

SURF BLUE AND COLONIAL WHITE, STYLE TONE, WITH OPTIONAL DRESS-UP PACKAGE



TAHITIAN BRONZE AND FAWN TAN, TWO TONE

RANCH WAGON

Handling and parking is a breeze with this spirited Ranch Wagon, the model that's first choice with those who seek a 2-door wagon at the *lowest* price. It gives you 17% more glass all around for better visibility, and the new *roll-down* center side windows provide new convenience to rear seat passengers. Select Ford's Mileage Maker Six engine with new low-cost Fordomatic Drive and you'll enjoy the *thriftiest* package of "wagon transportation" since the days of the ox-drawn Prairie Schooner! Or choose a Thunderbird V-8. Either engine is designed to be especially responsive in the speeds where most driving is done . . . from 30 to 70 mph!

New Diamond Lustre Finish

so durable you won't have to wax it . . . ever!

New Diamond Lustre Finish is the most durable finish on any car today. The uniform glass-like surface requires no "hand-finishing" to bring out its natural lustre. It's so glossy that *you won't have to wax it . . . ever!* This new enamel was subjected to searing tropical sun and corrosive salt air for months. And it *remained* showroom bright, proving that it has greater resistance to blistering, corrosion and stain than other finishes. As for toughness, BB gun tests showed it to be far more chip resistant than even Ford's famous enamels of the past.

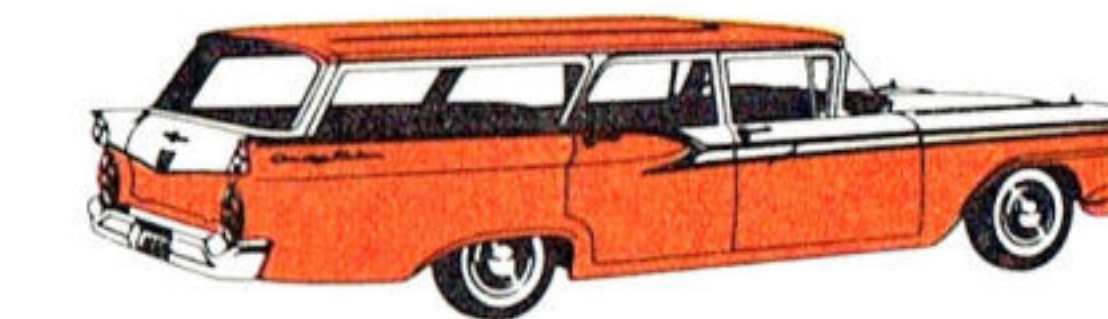

STYLE TONE COLOR COMBINATION

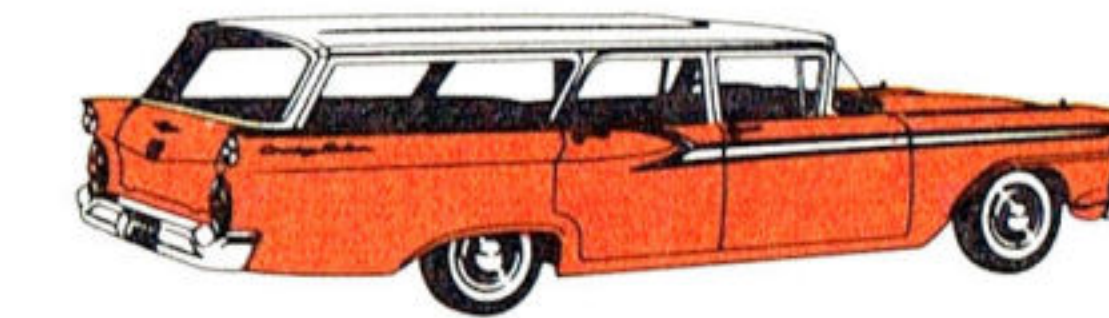

TWO TONE COLORS ON COUNTRY SEDANS

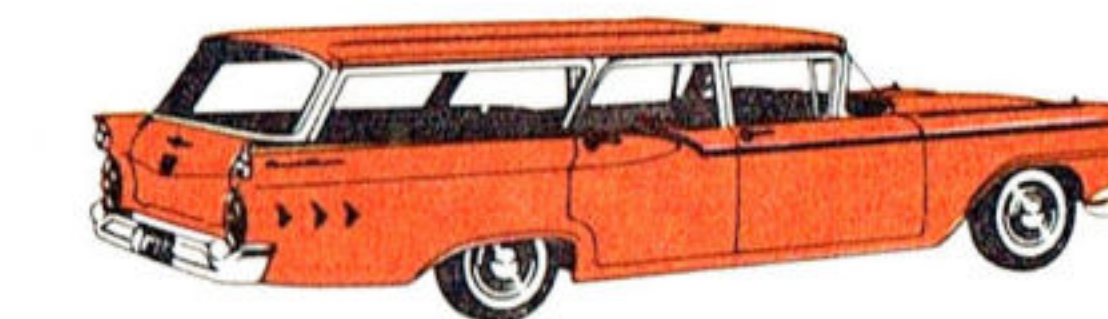

TWO TONE COLORS ON RANCH WAGONS

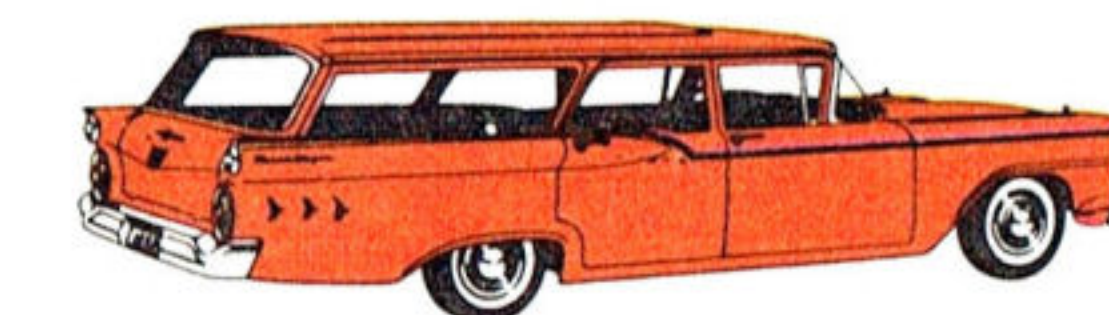

SINGLE COLOR

Fabulous new fabrics

Depend on Ford, the car that introduced the very *first* color-keyed interiors to the low-price field in 1951, to bring you the *newest* in station wagon interiors, too! Here are fabulous fabrics with the *durability* you want for carefree wagon living. And an all-new trim of "radiant" vinyl gives the interior a brighter, more spacious effect. Because it's less porous it's far easier to clean, too!

FORDOR RANCH WAGON

You'll love the life you lead in this 6-passenger model that combines the low price of a Ranch Wagon with the convenience of four wide-opening doors. It's so easy to load or unload passengers or payloads! And like all 59 Ford wagons, it is more spacious than any wagon Ford ever built . . . with a body measuring over 7 inches longer inside than last year . . . and over 42 sq. ft. of cargo area with stowaway seat down and tailgate open!

It's thrifty to maintain, too, with a new aluminized muffler that will normally last *twice* as long as conventional mufflers used on other wagons . . . plus a Full-Flow oil filter (*standard* on all 59 Fords!) which means you need change oil only every 4000 miles. Considered from any standpoint, this Fordor Ranch Wagon is proof that your wagon dollars buy more when you choose Ford!

Inside either of Ford's two Ranch Wagon models . . . you're seated in the lap of luxury! With the same elegance that made the Thunderbird so distinctive, Ford has selected color-keyed interiors to delight the eye. And notice the comfort of the thick seats that extend the *full width* of the wagon!

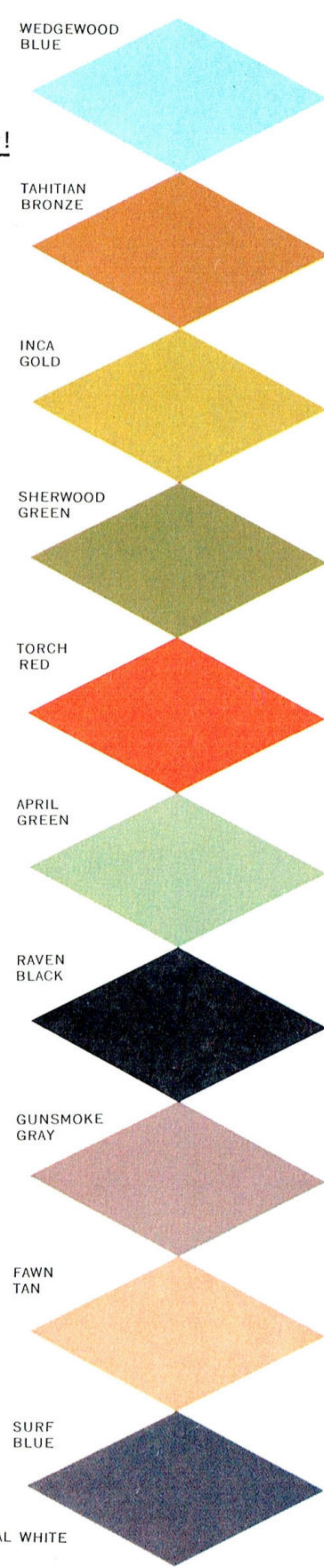
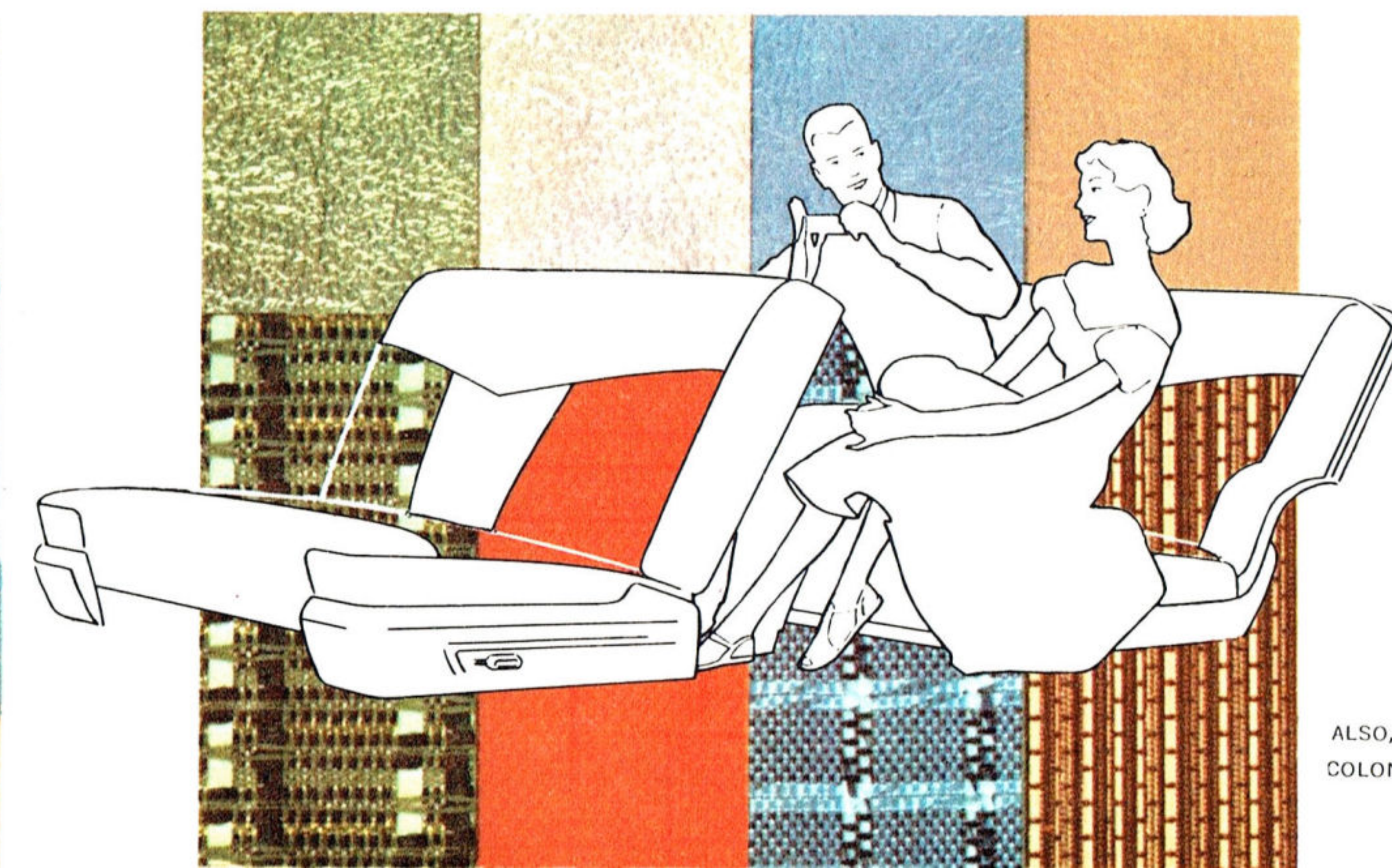

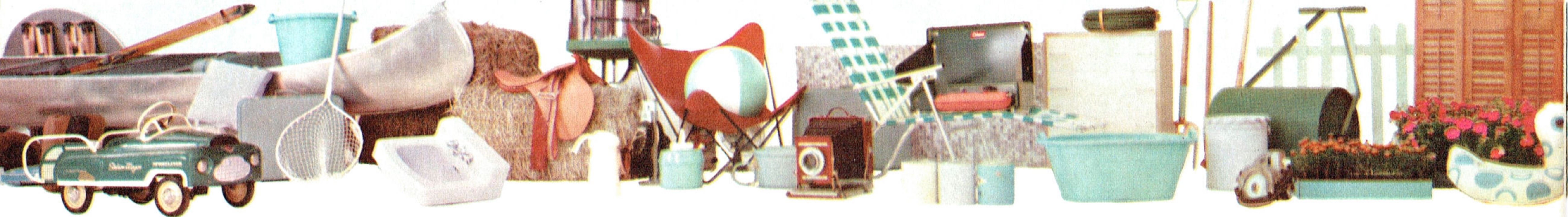

YOU RIDE SILENT, SOLID AND SECURE IN THE NEW INNER FORD

Ever since Ford pioneered the first station wagons back in 1929, Ford designers and engineers have achieved many important "break throughs" in station wagon design. One problem that has always defied solution has been the designing of a station wagon body as silent, solid, and secure as that built for conventional 2-door or 4-door sedans. Now Ford has solved even this problem! From new chassis to new roof, Ford's carefully interlocked body makes it the most rugged wagon in the low-price field. With this new body, you'll enjoy long silent service from any 59 Ford wagon you pick!

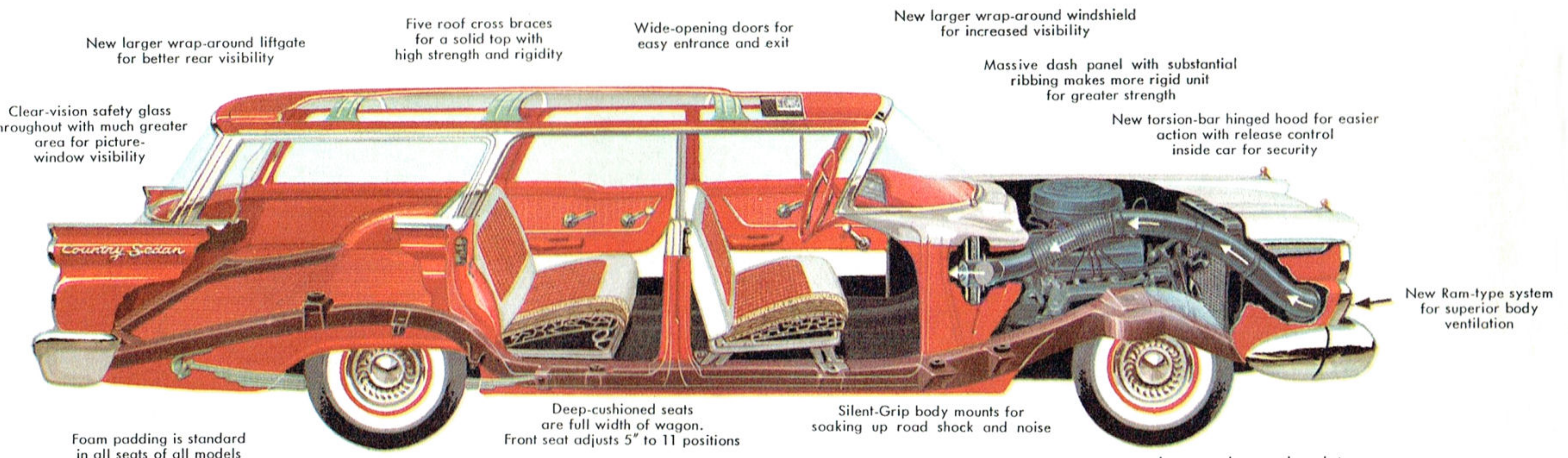

New larger wrap-around liftgate for better rear visibility
 Five roof cross braces for a solid top with high strength and rigidity
 Wide-opening doors for easy entrance and exit
 New larger wrap-around windshield for increased visibility
 Massive dash panel with substantial ribbing makes more rigid unit for greater strength
 New torsion-bar hinged hood for easier action with release control inside car for security
 Clear-vision safety glass throughout with much greater area for picture-window visibility
 New Ram-type system for superior body ventilation
 Foam padding is standard in all seats of all models (except rear seat in Ranch Wagons) for luxurious, easy-chair comfort
 Deep-cushioned seats are full width of wagon. Front seat adjusts 5" to 11 positions
 Silent-Grip body mounts for soaking up road shock and noise
 Larger rocker panels and stronger double-ribbed floor pan with five reinforcing floor members for high rigidity

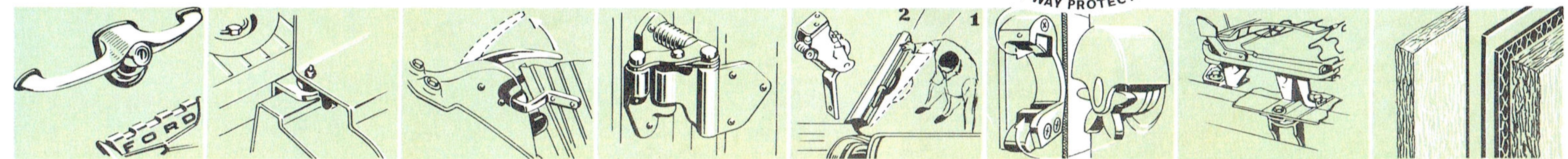

New tailgate handle is easily gripped with either hand. Features push-button design with new key locking cylinder.
New tab on tire well cover gives extra theft protection for spare tire. Larger tire well area gives extra storage space, too.
Special safety catch at right side of back rest locks seat in "up" position. 9-passenger models have two catches, one on each side.
Automatic Doorman hinges help swing the rear doors full-open or full-closed. They are sturdier with larger bolts than before.
Two-stage door checks hold front door open in two positions: two-thirds or all the way. Features heavier, stronger bolts.
Double-Grip door locks have increased thickness of rotor and striker. They rotate rather than slide into position for easier operation.
Safety seat anchorage locks the front seat to the chassis frame. Heavy "stops" help hold tracks together in case of impact.
Superior insulation makes Ford the best-insulated car in its field. Roof insulation is half inch thick; 3-layer dash is one inch thick!

This is the most loadspace Ford has designed into any station wagon in over a quarter century of wagon leadership! Measuring nearly *ten feet* from back of front seat to the end of the open tailgate (illustrated at right), this loadspace area caused one viewer to remark, "Looks almost big enough for a bowling alley!" All Ford wagons give you 92 cu. ft. of cargo space inside . . . with an attractive, long-wearing ribbed vinyl floor. The wide tailgate and big, wrap-around liftgate pop open instantly with one, easy, single-handed motion. There's no extra cranking or power equipment needed. The tailgate is level in the down position, and the full-size rear opening provides the easiest loading ever. That's why these 59 Ford wagons are as *practical* for Monday's hauling as they are *beautiful* for Sunday's calling!



"Bowling Alley" Loadspace!

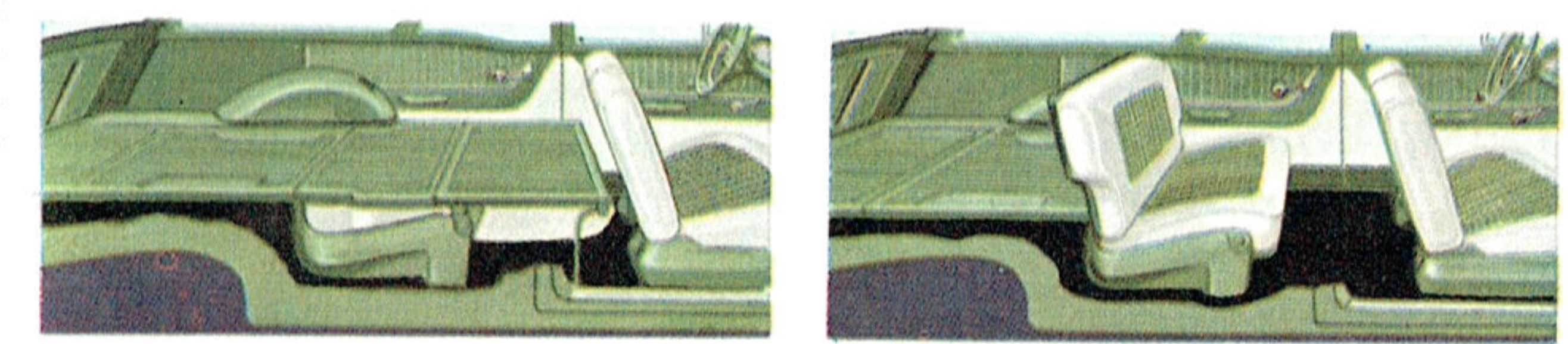

Fold the Stowaway seat down (easy!) and your 6-passenger wagon is all set to haul just about anything!
 With Stowaway seat up, 6-passenger wagons offer plenty of room and comfort for the entire family.



Two Stowaway seats in 9-passenger models tuck under easily to give you more loadspace than ever before.
 Set up the divided center seat in Ford's 3-seated wagons and there's room for six big passengers . . . and cargo, too!
 Only Ford in the low-price field offers you the natural comfort of three *forward-facing* seats in its 9-passenger models!

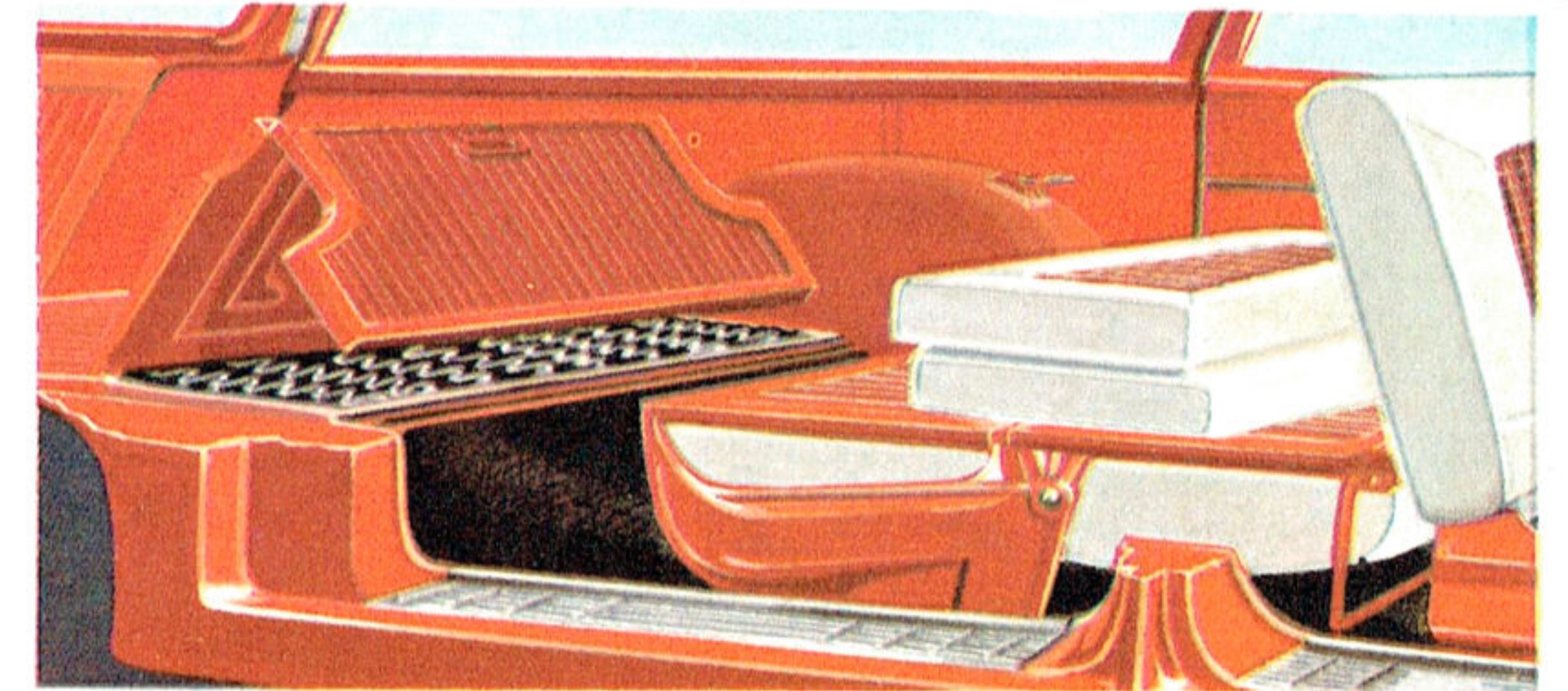

Ford's new third seat converts so quickly even a child can do it! Seat back simply folds down. Removable cushions may be stowed back of front seat or at sides, and they're wonderful as mattresses or picnic cushions.

300-hp Thunderbird 352 Special V-8

Here is the *newest* version of Ford's famous Thunderbird V-8 engine! This 4-barrel V-8 is designed to give you a responsive surge of lively power in the speeds where you do most of your driving: between 30 and 70 miles per hour. This is power you can use . . . not power you don't need at the top of the speed curve! Team this engine with Cruise-O-Matic Drive featuring a specially tailored gas-saving rear axle for "built-in" overdrive economy!

225-hp Thunderbird 332 Special V-8

For 1959 Ford engineers have equipped this engine with a 2-venturi carburetor that has new jets for improved fuel economy. Team it with Cruise-O-Matic or new, low-cost Fordomatic Drive and you'll make fewer stops for gas! Also, new super-fitted aluminum-alloy pistons have longer skirts for better oil control. Enjoy power as you like it . . . where you can *use* it!

200-hp Thunderbird 292 V-8

Now you can have Thunderbird V-8 power at surprisingly *low cost*! This standard Ford V-8, like all Ford engines for '59, has new wedge-shaped combustion chambers for better gas-saving performance . . . plus Ford's deep-block, short-stroke design. And it's designed to thrive on *regular* gasoline. Saves you money on every gallon!

145-hp Mileage Maker Six

This lively Six is the *only* modern 6-cylinder engine offered today. In the last two Mobilgas Economy Runs, its short-stroke, low-friction design was responsible for powering a Ford to the most actual miles per gallon of any car in Class A! What's more, it thrives on *regular* gas. You save up to 5¢ over premium fuel on every gallon!

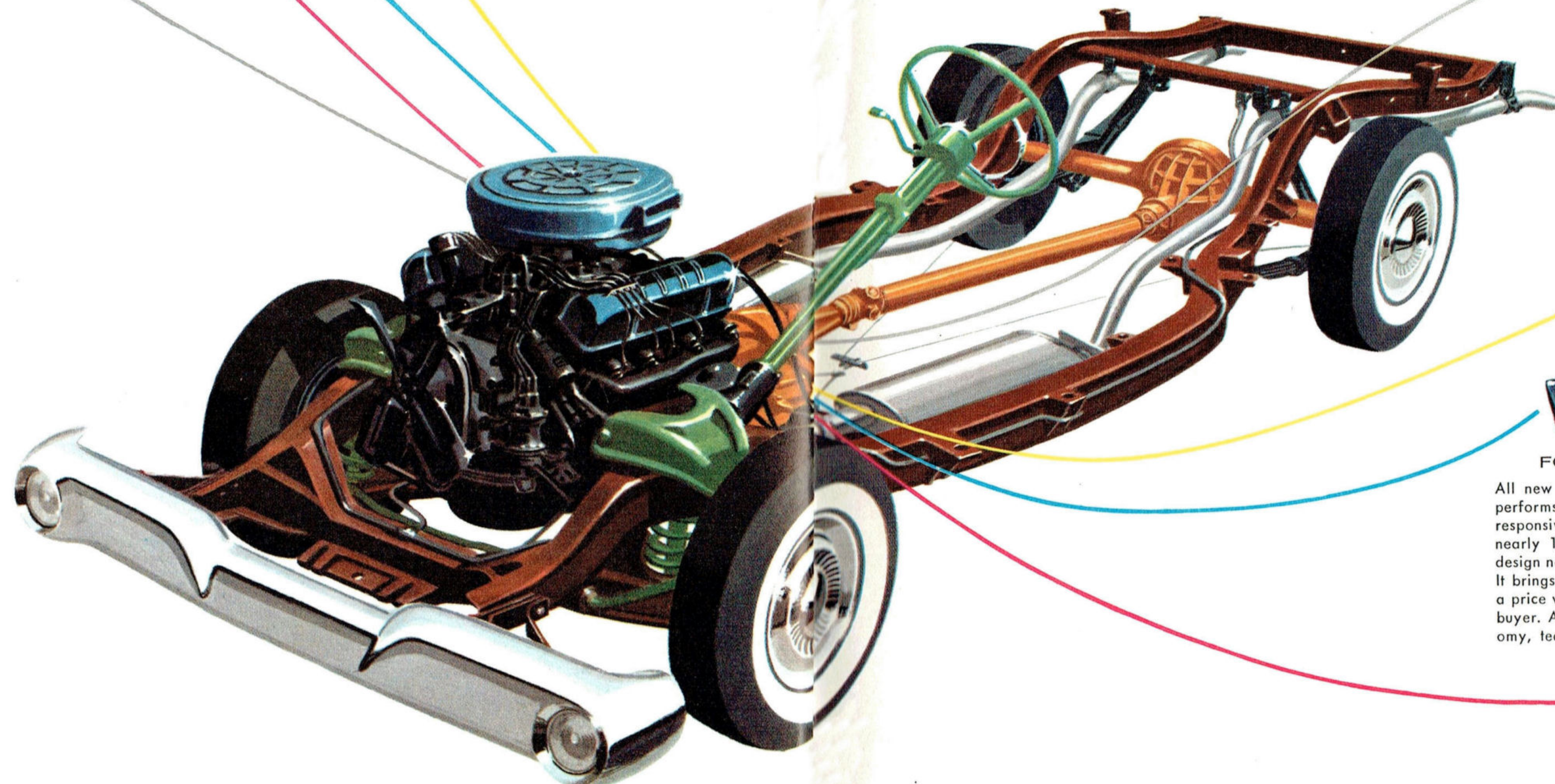
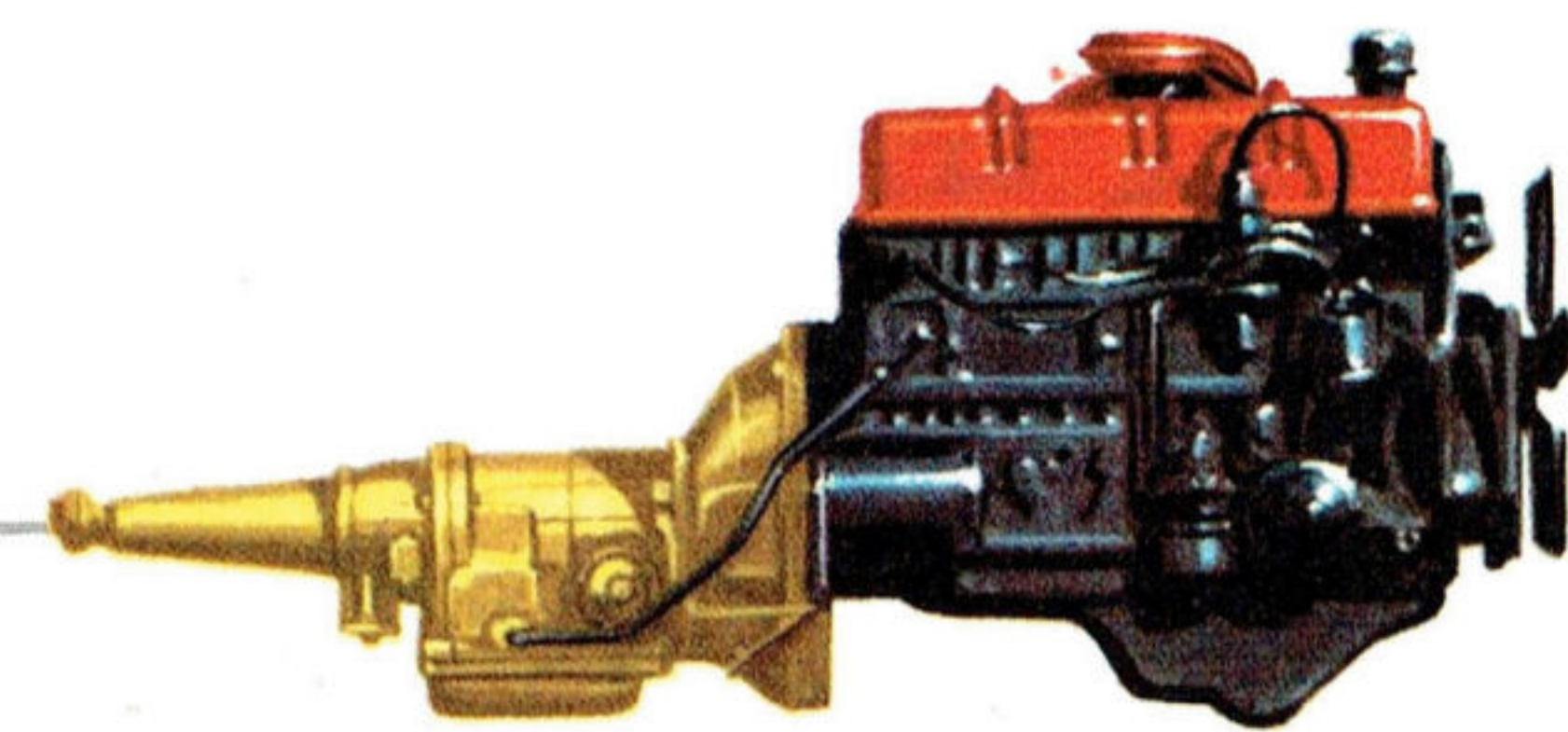
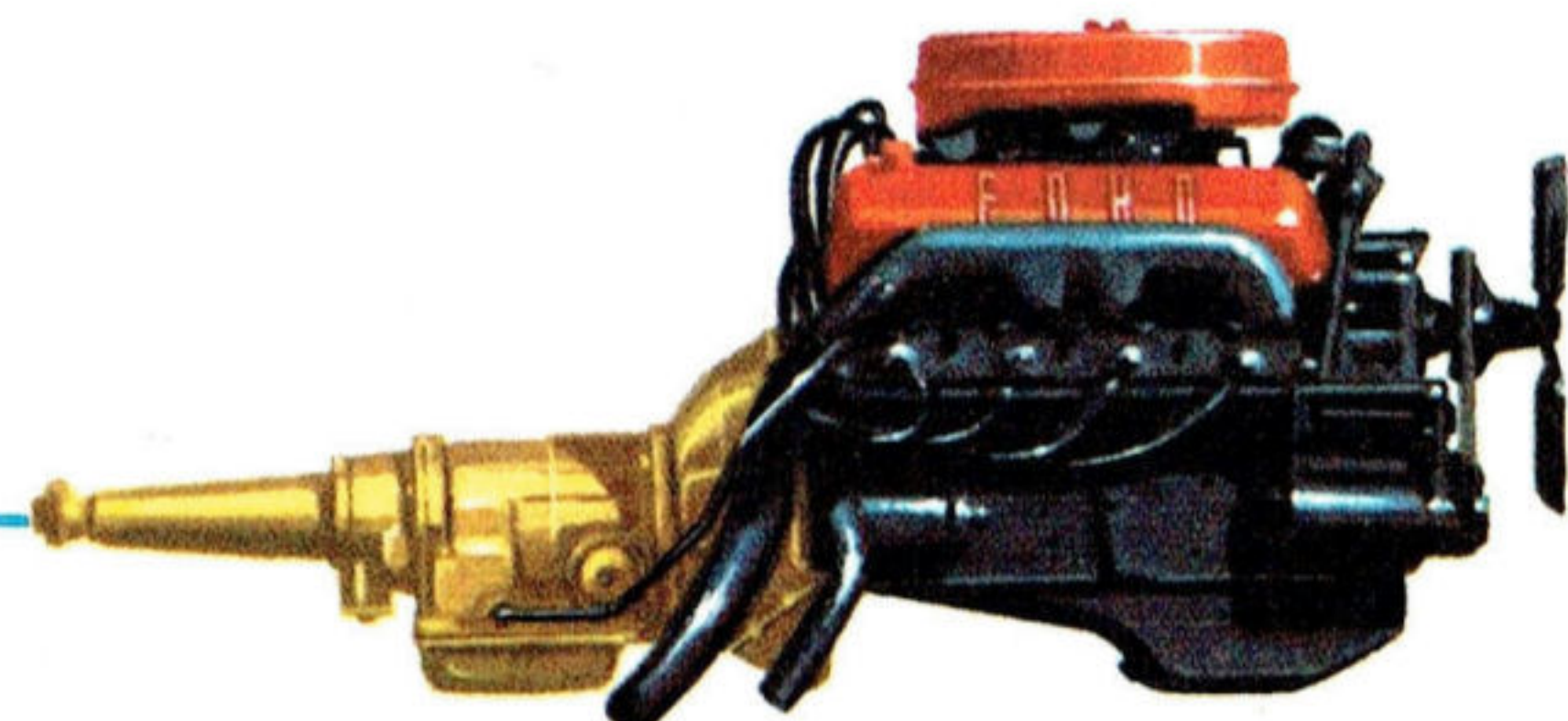
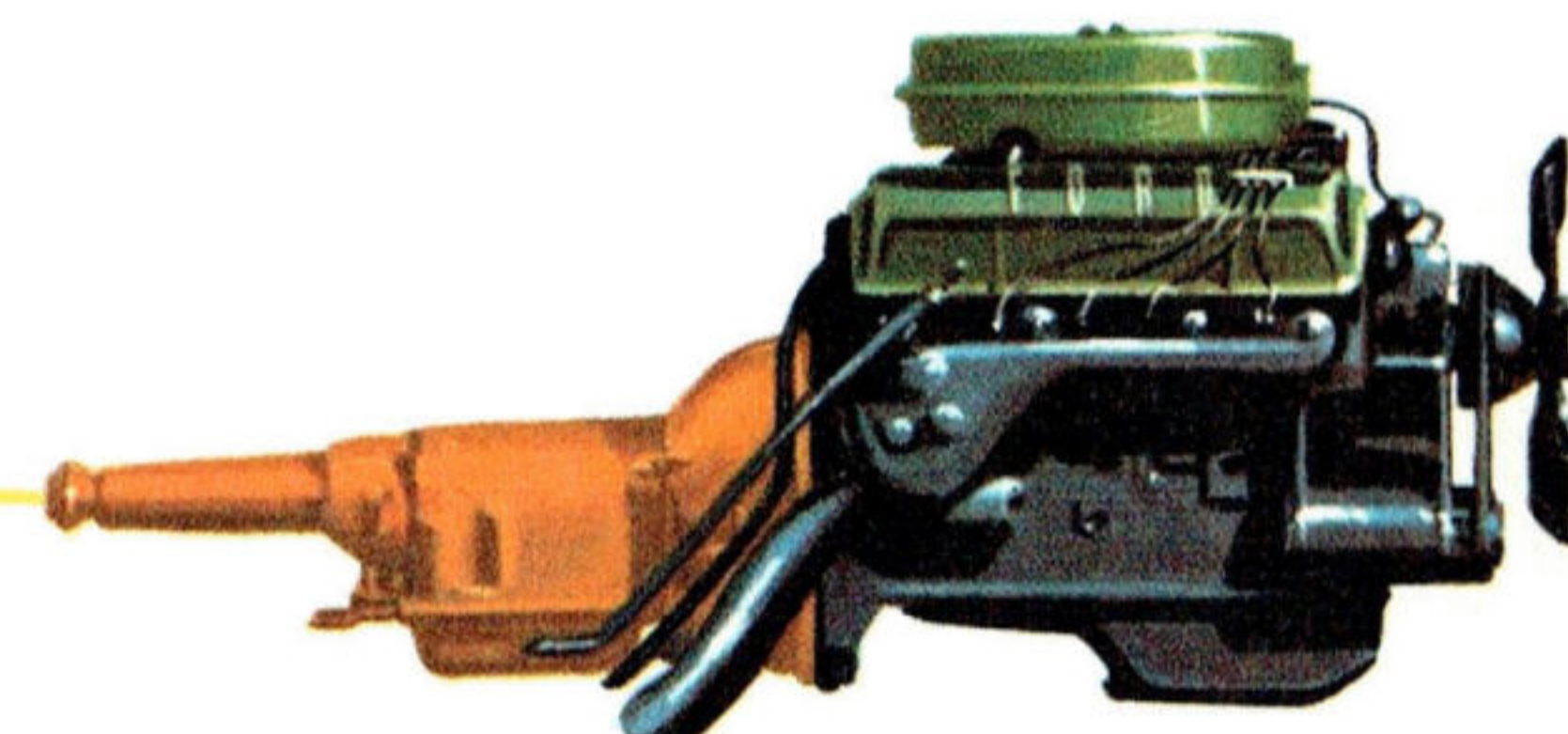
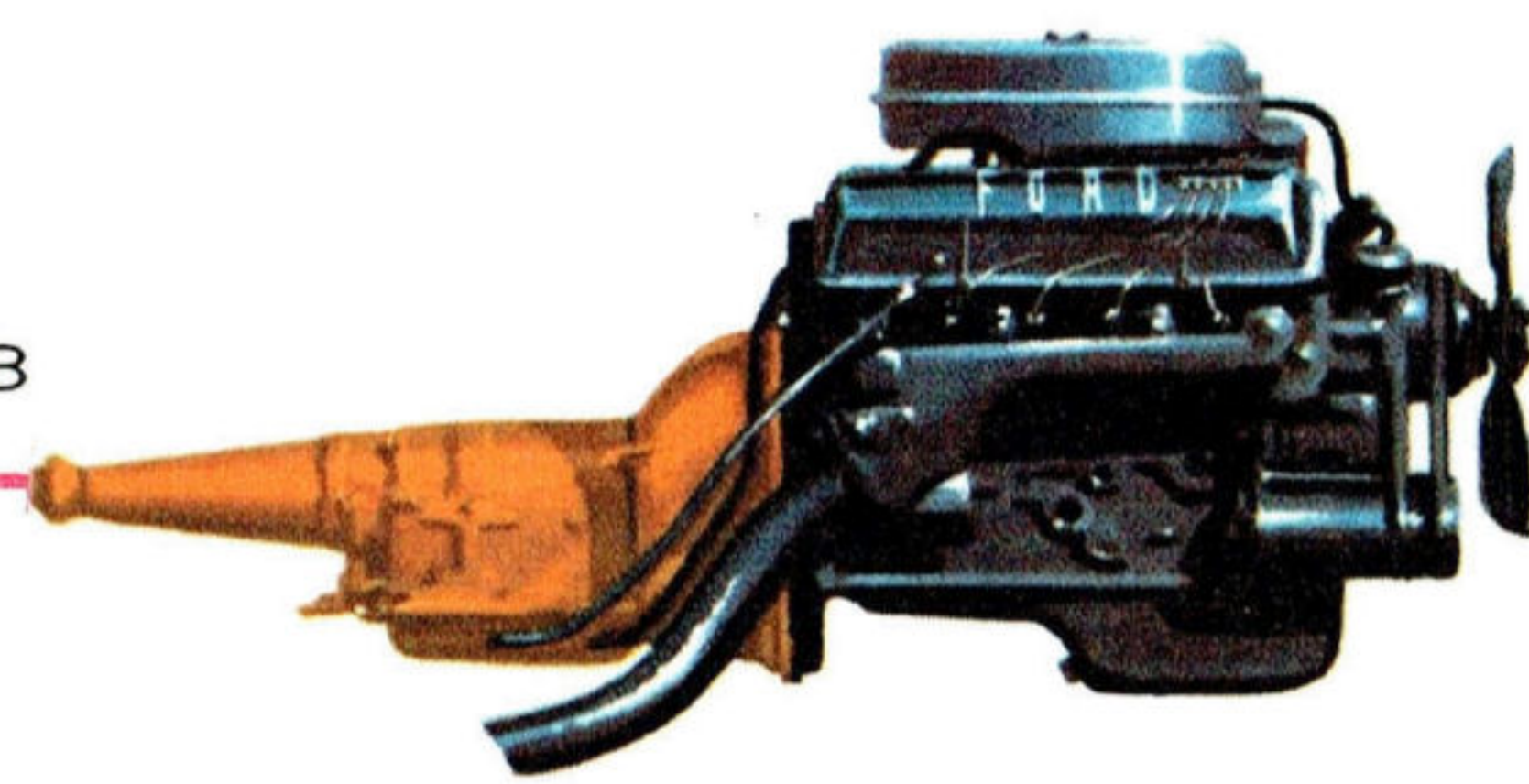

TRANSMISSIONS

CONVENTIONAL DRIVE

Here is the *easiest* manual shifting ever developed! To give you the utmost in economy, gear ratios have been carefully tailored to each engine. A lively performer!



FORDOMATIC DRIVE

All new for '59, this simplified automatic performs with satin smoothness and quick responsiveness. Lighter in weight with nearly 1/3 fewer parts, its more durable design normally requires very little service. It brings the benefits of shiftless driving at a price within reach of nearly any new-car buyer. And for really surprising gas economy, team it with a Mileage Maker Six!



OVERDRIVE

Saves on gas while it saves your engine! Automatic 4th gear lets your engine loaf at 35 mph while you actually do 50 mph. Saves up to 15% on fuel bills, too!



CRUISE-O-MATIC DRIVE

Enjoy "built-in" overdrive economy from a gas-saving rear axle with Cruise-O-Matic! It gives you two separate driving ranges: "D1" for all normal driving, delivers brisk, solid-feeling starts in low and smooth acceleration right up to superhighway cruising speeds . . . "D2" for gentle, sure-footed starts in intermediate, when you're on ice, snow or loose gravel.

NEW POWER . . . WHERE YOU CAN USE IT!

There's a big difference in Ford's Thunderbird V-8 engines for '59. They give you more responsiveness in the normal driving range between 30 and 70 miles per hour where you can *use* it . . . rather than at top speeds where you never need it! These powerful engines represent the *best* in power plants from the world's master engine builder—Ford. Nobody else builds so much rugged dependability and responsive performance into an engine.

As for economy, all Ford engines include a Full-Flow oil filter—that cleans all the oil all the time—as *standard* equipment. You need change oil only every 4000 miles. And, there's a vacuum-booster fuel pump for safer, more constant windshield-wiper operation.

RUGGED CHASSIS . . . NEW FROM TYREX CORD TIRES UP!

Here is the safest, most-tested chassis ever designed by Ford, the car that pioneered famous Lifeguard Design. Observe how Ford's husky frame bows out a full foot *wider* midway to give you greater protection than other wagons in the event of side impact!

All tires on Ford's '59 chassis are made of amazing new *Tyrex* cord, the cooler-running, longer-wearing cord that is the talk of the tire industry. On the front suspension is a new link-type, rubber-bushed ride stabilizer. This is teamed with Ford's variable-rate rear suspension to give you complete Automatic Ride Control!

PICK YOUR OWN POWER TEAM!

ENGINE	TRANSMISSION
145-hp Mileage Maker Six	3-Speed, Overdrive or Fordomatic
200-hp Thunderbird 292 V-8	3-Speed, Overdrive, Fordomatic or Cruise-O-Matic
225-hp Thunderbird 332 V-8	Fordomatic or Cruise-O-Matic
300-hp Thunderbird 352 V-8	3-Speed, Overdrive, Fordomatic or Cruise-O-Matic

New convenience! A foot-operated parking brake—a luxury feature that is standard equipment on every '59 Ford! Brake may be set at various "on" positions; releases by a hand-operated release lever.

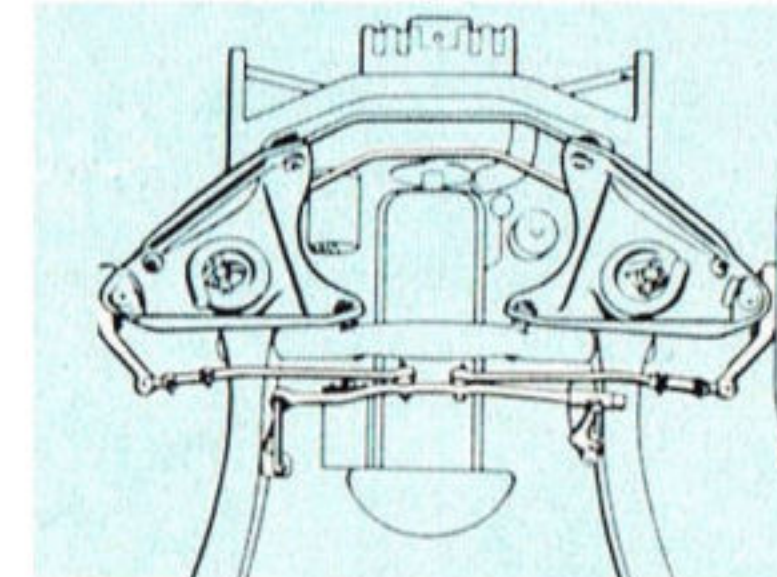
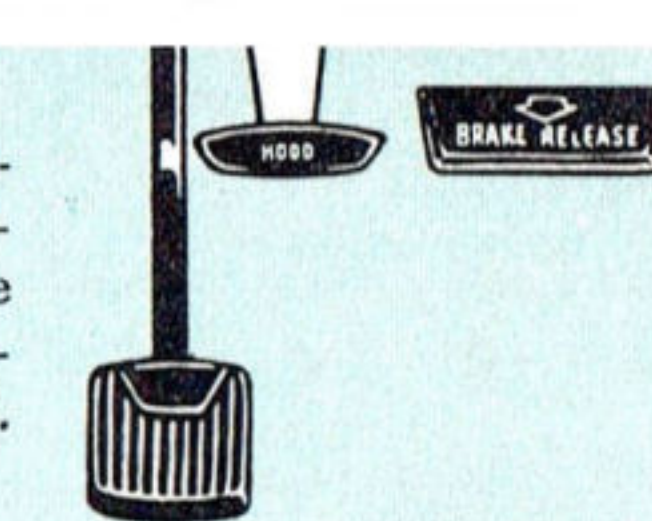

Exclusively Ford is the swept-back, Angle-Poised Ball-Joint front suspension that now features a new, link-type ride stabilizer. Helps give your wagon a smooth, limousine-like ride!

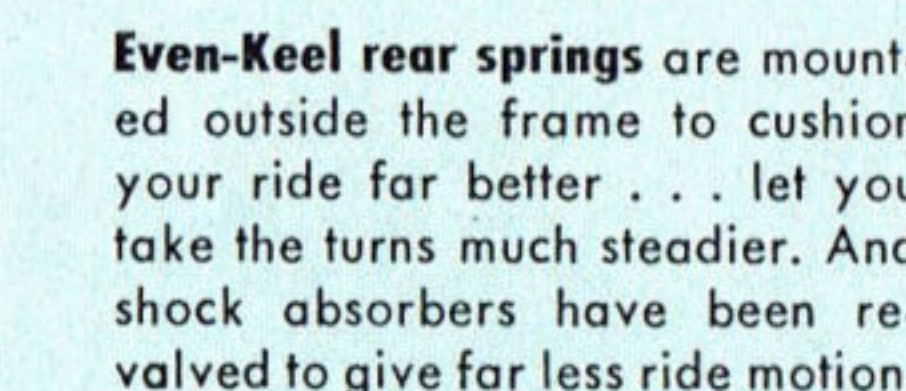

Even-Keel rear springs are mounted outside the frame to cushion your ride far better . . . let you take the turns much steadier. And shock absorbers have been revalved to give far less ride motion.

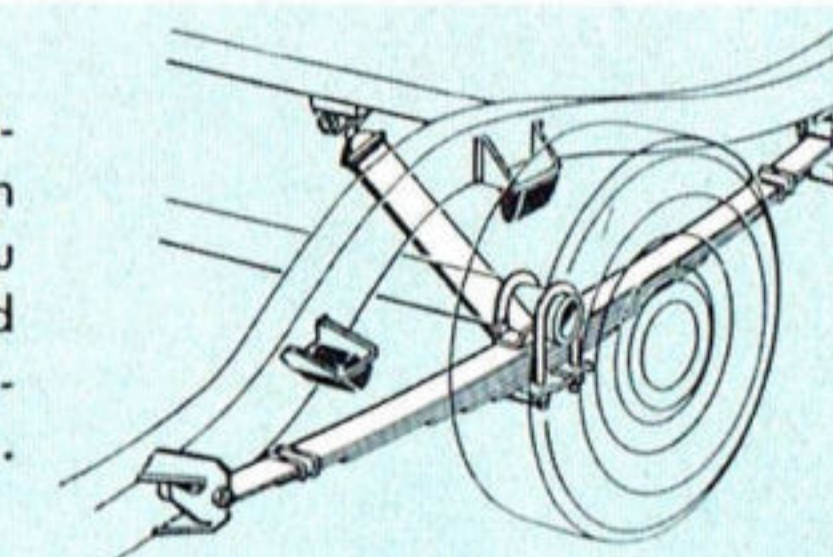

Heavy-duty springs are optional (at extra cost) with any Ford Station Wagon. Designed especially for wagons used for heavy hauling, the leaves are heavier than those used in all-purpose wagons.

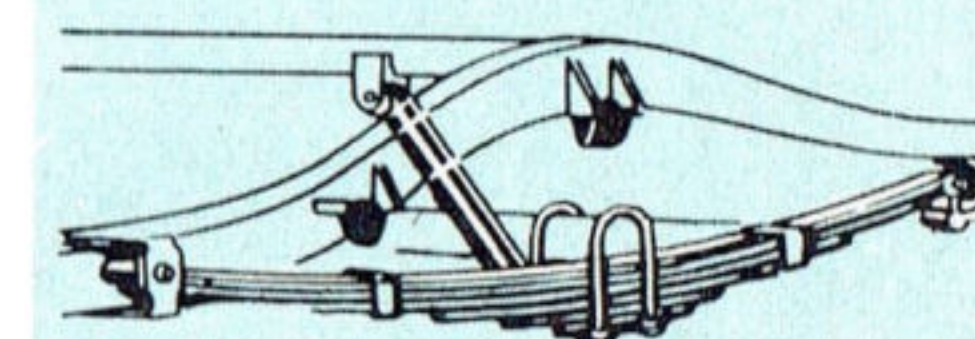

Ford's Magic-Circle steering is the closest thing yet to power steering! The steering wheel turns on free-rolling steel balls instead of the conventional worm-gear. This efficient design gives you easier turning and far smoother over-all handling!

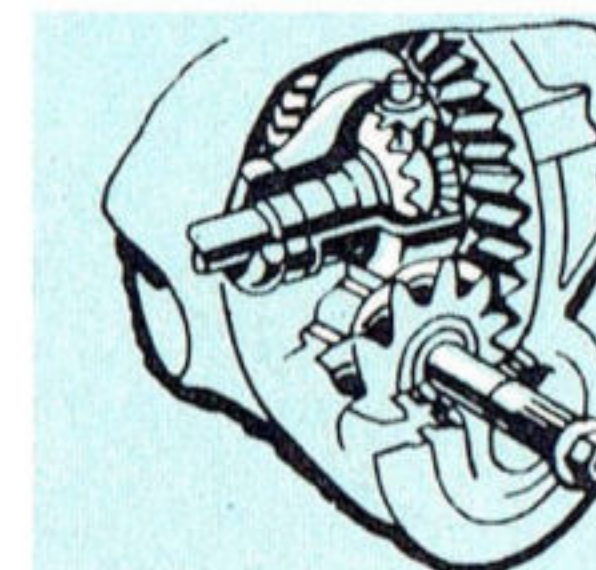
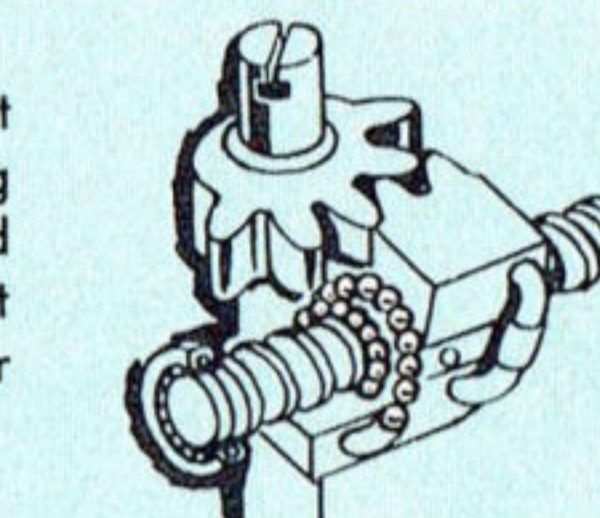

A deep-offset hypoid rear axle permits Ford to straddle mount the drive pinion. It allows larger gear teeth on both ring and pinion gears. This permits lower drive line positioning; boosts efficiency.

Ford brakes are double sealed to help you stop safer in all weather. They feature a fixed-anchor design that requires only a simple, single-point adjustment. All wagon brake linings are riveted and have 191 square inches of lining area for longer life.

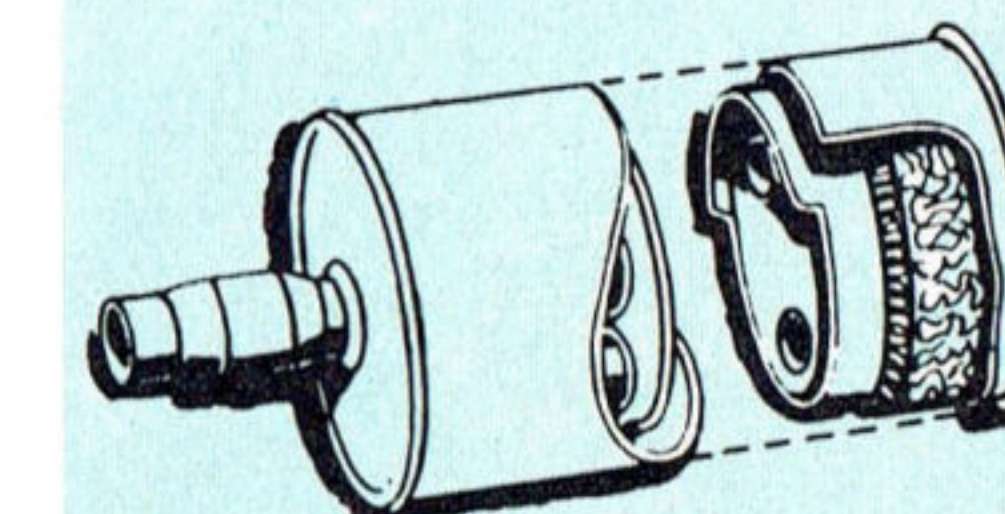
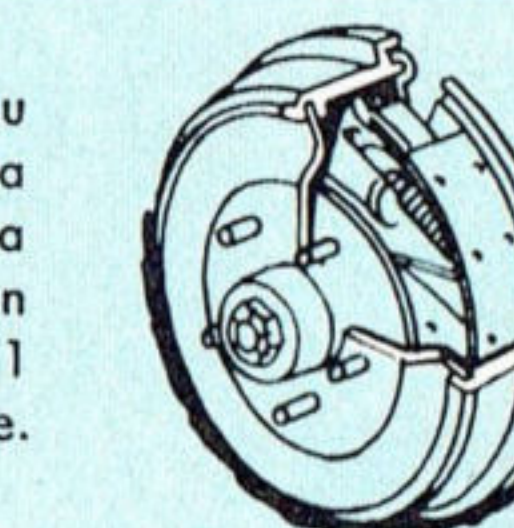

A brand-new aluminized muffler helps keep operating costs low. Protected by an aluminum coating it will normally last *twice* as long as conventional mufflers used on other wagons.

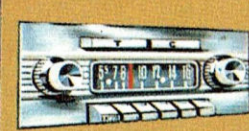

Signal Seek Radio† automatically tunes in station in either direction of the dial. Town button (T) tunes local stations, Country (C) gives broad coverage.

†Transistor-Powered

Console Range Radio is transistor powered, yet is still moderately priced. Automatic push-button tuning gives you a choice of any five preselected stations.



MagicAire Heater is all new for '59! Not only does it heat more quickly, but its new finger-tip control gives the temperature you want—*instantly!*

SelectAire Conditioner has large compressor and strategic placement of air registers. You get refrigerated cooling, ventilating, heating and defrosting in one compact unit (V-8's only).

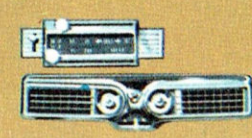

Self-Regulating Electric Clock retimes itself automatically each time you set it! The smart functional design is accentuated by illuminated dial.

PolarAire Conditioner offers cool comfort at surprisingly low cost (V-8's only). Its "on-off" magnetic clutch controls car temperature automatically.

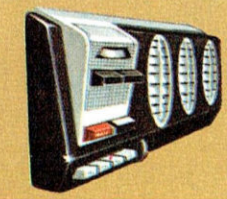

Visored Spotlight Mirror gives night-and-day convenience. And the hooded feature makes it effective in all weather. Adjusts easily from inside car.

Adjust-O-Ring Mirror gives you a wide range of adjustment. Its clear-view mirror and ring visor provides protection against rain and snow.



GENUINE FORD OPTIONS AND ACCESSORIES FOR 1959

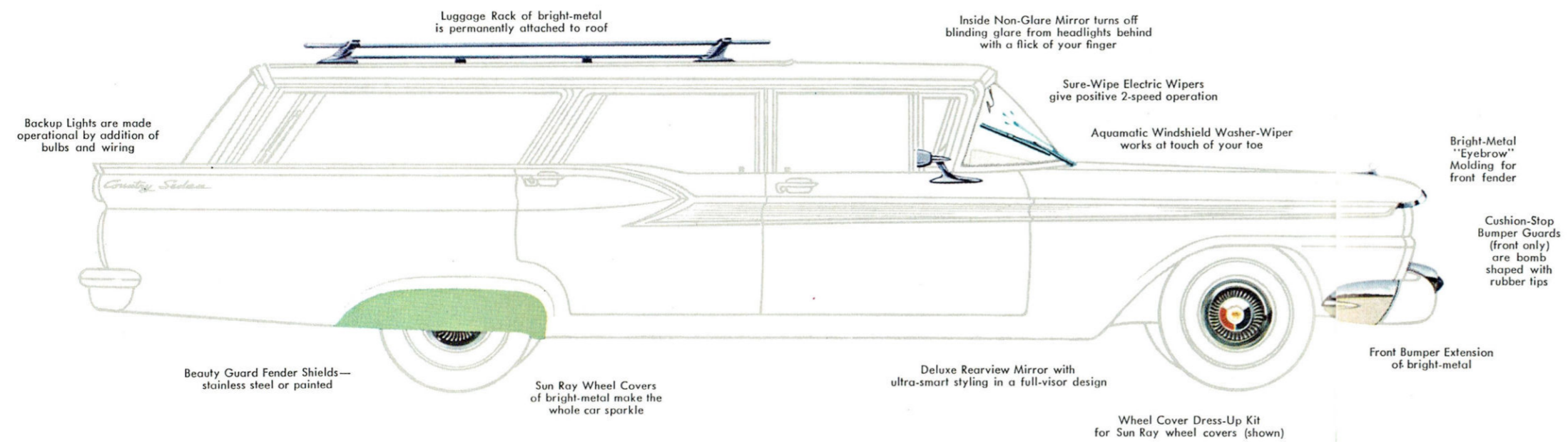

POWER ASSISTS

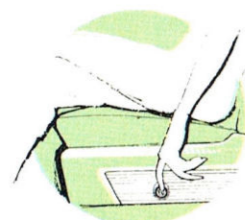

Power Front Seat. Touch a button and your seat automatically goes forward, backward, up or down. It's an infinite position, posture-control seat with synchronized tilting back. Here's comfort as you like it!

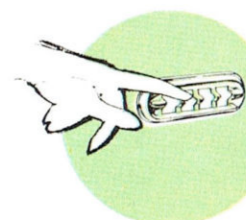

Power-Lift Windows. Touch the central control button on the driver's door and you can raise or lower any door window. For passenger's convenience, there's a handy button under each window, too.

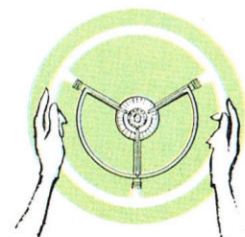

Master-Guide Power Steering cuts your parking effort up to 85% and assists you in all your driving. Yet you retain the "feel of the wheel" when steering on all types of roads—rough or smooth.

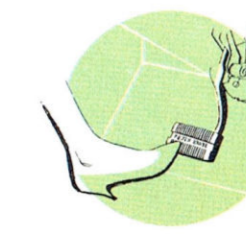

Swift Sure Power Brakes with a low pedal are the brakes you love to touch. Stopping takes up to 1/3 less effort. Makes driving in traffic much easier, more relaxing. It's just touch and "whoa!"

SAFETY FEATURES FOR '59

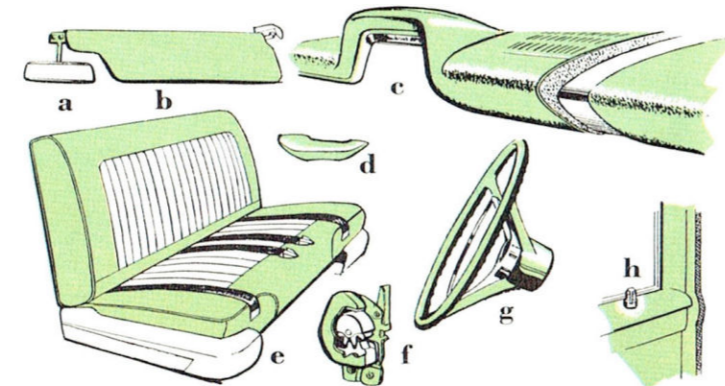

- a Lifeguard safety-swivel rearview mirror
- b Lifeguard sun visors*
- c Lifeguard cushioning*
- d Lifeguard arm rests

- e Seat belts*
- f Lifeguard door locks
- g Lifeguard deep-center steering wheel
- h Lifeguard Jr. safety locks*

*Optional at slight extra cost

OTHER FINE FORD OPTIONS

4-WAY MANUAL TILT FRONT SEAT
FULL TONE MANUAL RADIO
RECIRCULATING HEATER & DEFROSTER
I-REST TINTED GLASS
DRESS-UP PACKAGE

(Ranch and Fordor Ranch)

SOUND DEADENER PACKAGE
FULL-VIEW MIRROR
VISORED FULL-VIEW MIRROR
FRONT LICENSE PLATE GUARD
LICENSE PLATE FRAMES
FLYING ELLIPSE HOOD ORNAMENT
SNAP-ON CARGO COVER
CARGO AREA FLOOR MAT
EQUA-LOCK DIFFERENTIAL
PARKING BRAKE SIGNAL
VANITY MIRROR
TISSUE DISPENSER
LITTER BAG
LOCKING GAS CAP
FLOOR MATS, CONTOUR—
Front, Rear and Twin Front
VENTILATED SEAT CUSHIONS
SEAT COVERS

Set your family TWO-FORD FREE

Why not select one of the station wagons in this catalog plus one of the beauties shown here? The cost for both will still be less than any one of the expensive cars . . . but what a difference in family freedom! Make up the best combination for your family. And remember: they're all yours at Ford prices!

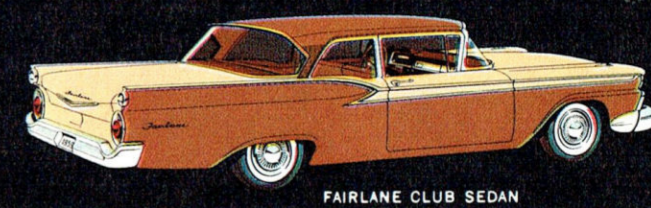

FAIRLANE CLUB SEDAN

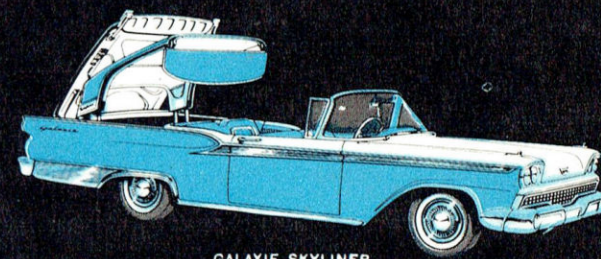

GALAXIE SKYLINER

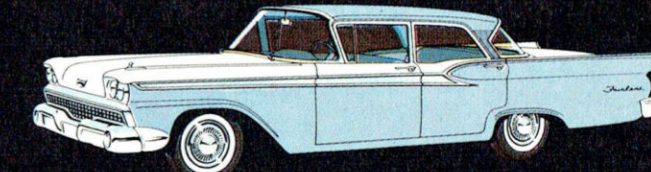

FAIRLANE TOWN SEDAN

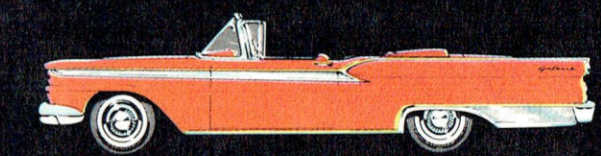

GALAXIE SUNLINER

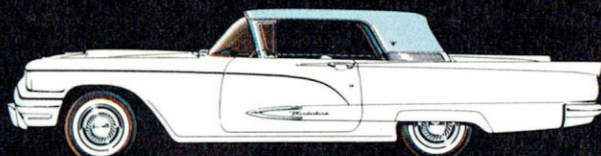

THUNDERBIRD HARDTOP

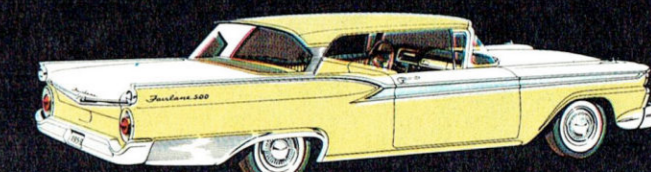

FAIRLANE 500 CLUB VICTORIA

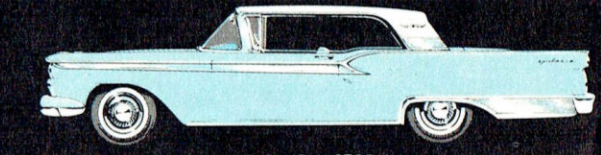

GALAXIE CLUB VICTORIA

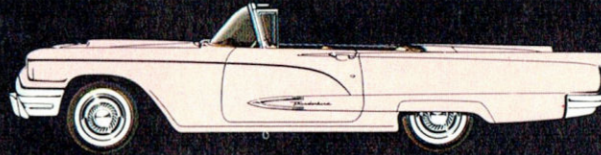

THUNDERBIRD CONVERTIBLE



CUSTOM 300 FORDOR

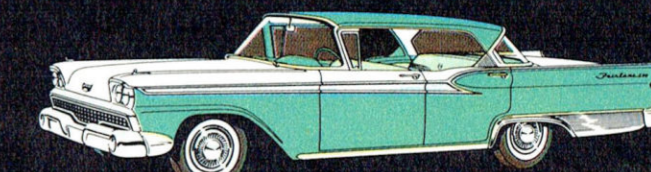

FAIRLANE 500 TOWN VICTORIA

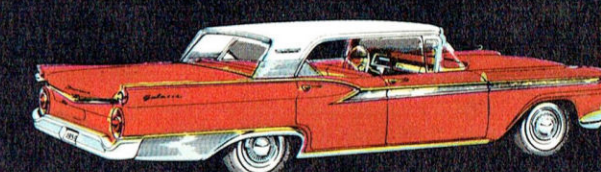

GALAXIE TOWN VICTORIA



CUSTOM 300 TUDOR

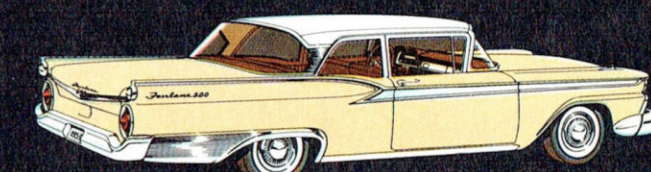

FAIRLANE 500 CLUB SEDAN

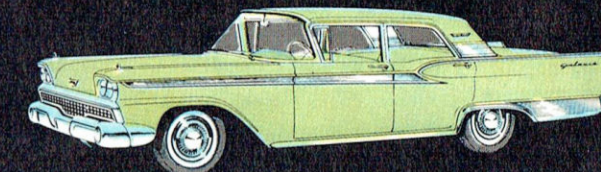

GALAXIE TOWN SEDAN



CUSTOM 300 BUSINESS SEDAN

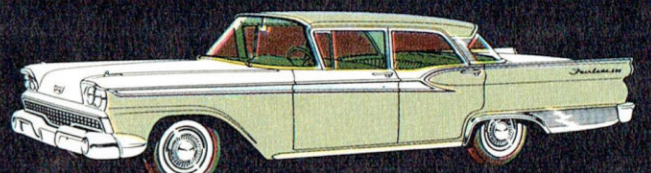

FAIRLANE 500 TOWN SEDAN

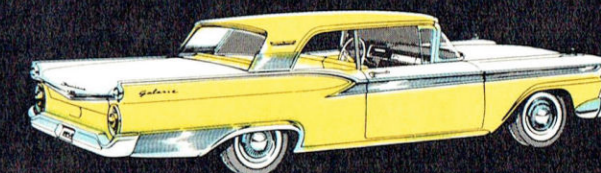

GALAXIE CLUB SEDAN

SPECIFICATIONS

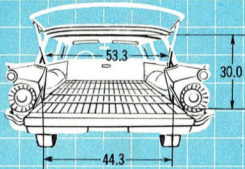

Exteriors: Amazing new Diamond Lustre Finish, most durable body finish ever developed, is available in 11 exciting colors. Single Color is available on all models; conventional Two Tone and Style Tone combinations are available on all models except the Country Squire. Basic colors are: Raven Black, Colonial White, Gunsmoke Gray, Surf Blue, Wedgewood Blue, Sherwood Green, April Green, Torch Red, Tahitian Bronze, Fawn Tan and Inca Gold.

Interiors: Beautifully upholstered in a rich variety of long-lasting, patterned woven plastics or vinyls, with Sof-Textured vinyl bolsters on Ranch Wagons and all-new Radiant Sof-Textured vinyl bolsters on Country Sedans and Squire. This new vinyl—a Ford "first"—has a super-high-metallic coating that gives the interior a brighter, more spacious effect. Headlining in all models is new color-keyed, basket-weave pattern composition board that is more durable and easier to clean. Floor covering is practical Sof-Tred carpet-textured black rubber up front, and long-wearing, color-keyed ribbed vinyl in the loadspaces. See the full selection of colors and fabrics at your Ford Dealer's.

Engines: 145-hp Mileage Maker Six—273-cu. in. displ.; 3.62" bore x 3.60" stroke, 8.4:1 comp. ratio; regular fuel, manual choke.
200-hp Thunderbird 292 V-8 (Standard V-8 on all models)—292-cu. in. displ.; 3.75" bore x 3.30" stroke; 8.8:1 comp. ratio; regular fuel; low-silhouette 2-venturi carburetor, automatic choke, Y-type single exhaust.

225-hp Thunderbird 332 Special V-8 (Optional on all models)—332-cu. in. displ.; 4.00" bore x 3.30" stroke; 8.9:1 comp. ratio; premium fuel; low-silhouette 2-venturi carburetor, automatic choke, Y-type single exhaust.

300-hp Thunderbird 352 Special V-8 (Optional on all models)—352-cu. in. displ.; 4.00" bore x 3.50" stroke; 9.6:1 comp. ratio; premium fuel; low-silhouette 4-venturi carburetor, automatic choke, dual exhausts.

Engine Features: For greater economy and longer life, all Ford engines have Short Stroke, low-friction design, with Deep-Block construction; intake and exhaust valves of free-turning, overhead type; Super-Filter air cleaner with reusable paper element; vacuum-booster fuel pump for more constant windshield-wiper action; full-pressure lubrication with Full-Flow disposable-type oil filter; weatherproof, high-capacity 12-volt electrical system; Turbo-Action 18-mm. spark plugs designed for increased gas mileage; exhaust system featuring new aluminum muffler. V-8 engines are electronically balanced while operating under their own power for extra smoothness. Thunderbird Special V-8's feature self-adjusting, hydraulic valve lifters for quietness and Precision Fuel Injection for superior performance and economy.

Fordomatic Drive: All new for '59, Fordomatic uses a single-stage, 3-element torque converter and a compound planetary gear set. These are incorporated into an automatic mechanism that requires only one clutch assembly to provide two "forward" gear ratios . . . low and direct . . . and reverse. In "D" range it provides brisk, smooth starts in low. This simplified design uses 27% fewer parts and with its cast-aluminum construction is much lighter in weight. This new Fordomatic is so dependable that after initial 1000-mile break adjustment, it requires normal servicing only each 24,000 miles. Available with all engines.

Cruise-O-Matic Drive: A high-performance automatic featuring two selective drive ranges—smooth 3-speed operation in "D1" range, starting in low for solid, full-power getaways and all normal driving . . . or 2-speed operation in "D2" range, starting in intermediate for gentle, sure-footed acceleration on ice, snow or loose gravel. Coupled with specially tailored gas-saving rear axle ratios, it provides "built-in" overdrive economy. Available with all V-8 engines.

Litho in U.S.A. Rev. 10-58

Wide-Contoured Frame: Strong, stiff, box-section frame with 5 cross members. Side rails extend outside passenger area, for better foot room and increased side protection. Silent-Grip body mounting system.

Suspension: Sweep-Back, Angle-Poised Ball-Joint front suspension has threaded, permanently lubricated bushings in upper control arms and soft coil springs for an easier ride. Front end of all models has new link-type, rubber-bushed ride stabilizer to control roll on turns. Even-Knit rear springs provide soft action, variable rate with tension-type shackles and wind-up control rubber bumpers over springs. Viscous-control shock absorbers, front and rear, give complete ride control. Heavy-duty rear suspension also available for those wagons that carry full-capacity loads most of the time.

Rear Axle: Husky, low-lung hypoid, semi-floating, with special Deep-Offset straddle-mounted pinion, permits lower car level without sacrifice of inside room. Torque-Tailored Ratios (to 1): **Conventional Drive or Overdrive**—3.89 with Six or 292 V-8, 3.70 with 352 Special V-8. **Fordomatic Drive**—3.56 with Six or 292 V-8, 3.10 with 332 Special V-8, 2.91 with 352 Special V-8. **Cruise-O-Matic Drive**—3.56 with 292 V-8, 2.91 with 332 Special V-8 or 352 Special V-8. Optional Equo-Lock Differential Ratios (to 1): 3.70 with Six and 3-speed, Overdrive or Fordomatic; with 292 V-8 and all transmissions; also with 352 Special V-8 and 3-speed or Overdrive—3.10 with 332 or 352 Special V-8's and Fordomatic or Cruise-O-Matic.

Steering: Magic-Circle recirculating-ball type steering gear provides low friction, easy steering; 27 to 1 over-all steering ratio. 17½", 3-spoke, deep-center Lifeguard steering wheel. Approximately 40-foot turning diameter.

Brakes: Giant-Grip double-sealed, self-energizing hydraulic brakes have suspended pedal, dash-mounted master cylinder. Drum diameter is 11". Lining area is 191 sq. in. Optional Swift Sure power brakes have special low pedal and power reservoir tank.

Tires: 4-ply black tubeless tires of new Tyrex super cord on 5½" safety-type rims, standard on all models; 8.00 x 14 on 6-passenger models; 7.50 x 14 on 6-passenger models.

Dimensions: 118" wheelbase; 59.0" front, 56.4" rear treads. Over-all length, 208.0". Height (maximum with design load) 57.6" for 6-passenger models; 57.8" for 9-passenger models. For other dimensions, see illustrations at left.

Other Available Equipment: Heavy-duty springs and shock absorbers. Power front seat, Swift Sure power brakes, Master-Guide power steering, Power-Lift door windows. Dress-up package—Ice Ball fender ornaments, three bright-metal darts on rear quarter panels, right sun visor, front arm rest, cigarette lighter and color-keyed steering wheel with horn ring (Ranch and Ford Ranch Wagons). Overdrive, Fordomatic, Cruise-O-Matic. White sidewall tires.

Prices: All Power Assists, Optional Equipment and Accessories as well as some of the items illustrated or referred to in this catalog are at extra cost. For the price of the model with the equipment you desire, see your Ford Dealer.

Comparative information in this catalog was obtained from authoritative sources, but is not guaranteed. The specifications contained herein were in effect at the time this catalog was approved for printing. Ford Division of Ford Motor Company reserves the right to discontinue models at any time, or change specifications or design without notice and without incurring obligation.

Form No. FDC—4359

Compliments of

Your
Friendly
Ford
Dealer