

# GRANTURISMO CONVERTIBLE



MASERATI



DEALER  
BY PROCESS

*"I have raced and won in cars of all marques but I always had a special relationship with Maserati: not only were the cars safe, reliable and always absolutely technically avant-garde, but there was a very special friendship and atmosphere between myself and the marque, I felt completely at home."*

Juan Manuel Fangio

A UNIQUE **SENSATION**

2

THE POWER OF **BEAUTY**

6

BEYOND **COMFORT**

14

DESIGN MEETS **TECHNOLOGY**

20

FEEL **PROTECTED**

34

INTERIOR **HARMONY**

42

COLORS AND **EQUIPMENT**

50

MASERATI **WORLD**

62



# A UNIQUE **SENSATION**

Discover Italian craftsmanship in every handmade detail and every refinement—born of 95 years of unbroken tradition.



Maserati

MO 145 BD MO

MAI SP  
PROCESS

A close-up, high-angle photograph of a Maserati car's front grille and hood ornament. The grille features a series of curved, parallel slats. The hood ornament is a prominent, three-pronged trident, rendered in a highly reflective, metallic finish. The lighting creates strong highlights and deep shadows, emphasizing the car's sleek, aerodynamic lines and the intricate details of the ornament.

The tradition and technical heritage of Maserati have always been the hallmarks of cars recognized worldwide as masterpieces of style. Models which have become renowned for elegance and outstanding design thanks to continuous search for perfection in every detail, cars designed to give their owners the unique Maserati experience.

This is the tradition that Maserati celebrates in launching its first model of this type. The first convertible to be designed in the new Viale Ciro Menotti headquarters to have four comfortable seats without compromising in any way the unique, exciting handling of all Maserati cars, thanks to its powerful V8 engine with its unmistakable growl and a wide range of custom options which make every car the unique expression of its owner's personality.

Driving and travelling in a Maserati GranTurismo Convertible is a unique sensory experience: the sight, touch, sound and even the aroma of the car stimulate every sensation as well as the admiration of anyone who sees it. This extraordinary car puts a new and even more complete driving experience at the cutting edge of your persona, so that every drive is transformed into an unforgettable adventure.

Information Provided by:



Maserati



Information Provided by  
**DEAL SP**  
S-PROCESS

# THE POWER OF **BEAUTY**

Purity in the form of timeless styling.



Information Provided by:

**DEALER**  
BY PROCESS





Information Provided by:



# Another Pininfarina *masterpiece*

The Maserati GranTurismo Convertible bears the unmistakable mark of Pininfarina: the imposing and dynamic front punctuated by headlamps whose lines develop horizontally, blending perfectly into the form of the fenders, while the grille is crowned by the renowned Trident symbol in chrome.

The dynamism of the side view is accentuated by the short front overhangs as well as by the long bonnet; three air intakes in pure Maserati style with chrome profiles lighten the front fender. The side panels are adorned with chrome detailing to increase their distinctiveness, further accentuated by the «ray of light» sculpting under the doors, resulting in an airy styling whose dynamic nature is highlighted by the car's standard 20-inch alloy wheels.

The rear of the Maserati GranTurismo Convertible emphasizes its sporty, highly technological nature: the triangular tail lights use 96 LEDs to help ensure immediate nighttime recognition, while the wide aerodynamic diffuser is framed at the sides by two pairs of large diameter chrome exhaust tailpipes situated at the bottom of the bumper. With the retractable roof closed, the car has an elegant but decisively dynamic profile. Just one touch of the soft top control button opens the roof in 24 seconds, and brings its beautifully stunning interior into complete focus.

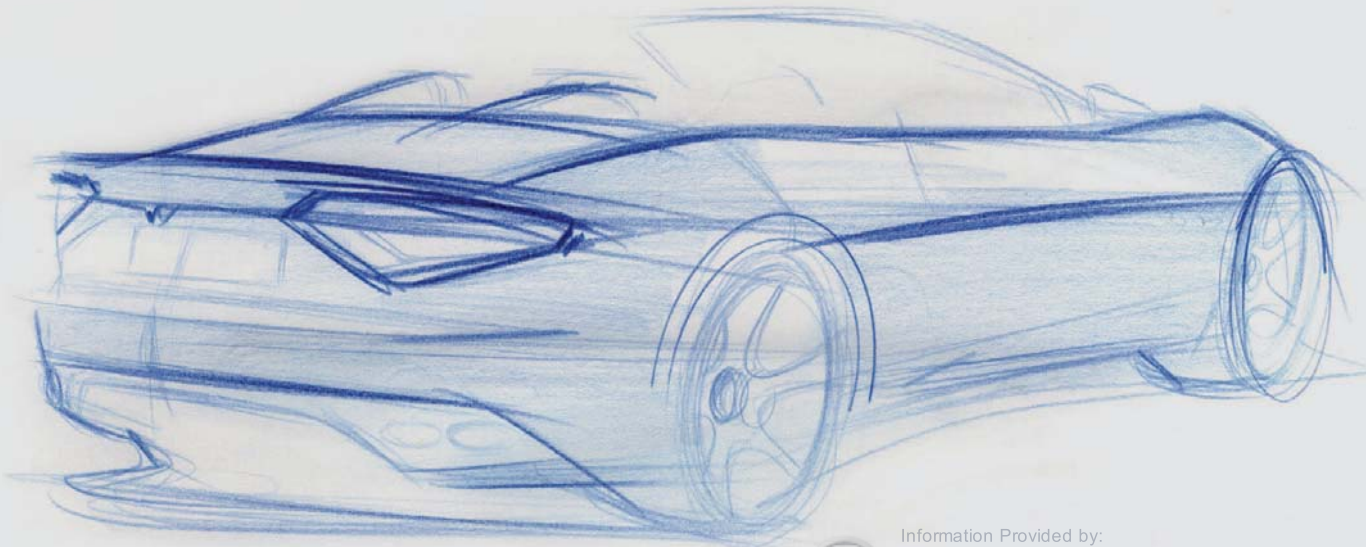

Information Provided by:

**DEALER**  
E-PROCESS



The Maserati GranTurismo Convertible's muscular exterior projects a natural and expansive fluidity of surfaces which start from the impressive grille and define the entire side up to the rear lights; the fenders encompass the large, exclusive Maserati alloy wheels creating a powerful and elegant statement.

The Maserati GranTurismo Convertible is a genuine four-seater which enables all four passengers to enjoy the experience of driving with the top down to the fullest. The rear seats, each of which are separate buckets, are designed the same as the front seats, provide a welcoming and expansive personal environment. An automotive space as pleasurable for the passengers as it is for the driver.



# The soft top: a decisive stylistic component



To create the GranTurismo Convertible, while maintaining its award-winning automotive design, its developers selected a retractable multi-layer soft top, permitting a huge range of color combinations while maintaining functionality, space and light weight requirements. The complete soft top system weighs a mere 143 lbs, maintaining the excellent low center of gravity of the GranTurismo with the top open or stowed.

Composed of five steel and aluminum frames which firmly support soft top even up to the impressive top speed of 176 mph (283 kmh), the roof has been designed for all-season functionality. Using an integrated, tempered thermal glass rear window which makes the car just as drivable in all seasons, the three-layer top helps isolate the passenger compartment from the exterior weather and noise while providing the comfortable environment worthy of a Maserati.





The durability of the soft top system has been proven in a battery of stringent tests exposing the roof to the world's most challenging weather conditions. The result is a roof composed of a triple-layer fabric. This is available in six standard colors to satisfy a variety of tastes (black, blue, burgundy, chocolate, titanium grey and java—a classic beige). The exterior roof colors are complimented by three available headliners: black, beige and beluga grey.



Information Provided by:



During warmer days of the year, the Maserati GranTurismo Convertible makes getting into the car more enjoyable by means of a summer opening feature allowing the top to be opened from the outside. When the key is inserted into the driver's door lock and turned clockwise for more than two seconds, the top starts to raise and fold away. This means that the top is down and ready for open air driving immediately (the system also closes the top, by turning the key window counterclockwise).

If inclement weather arrives, just slow down to 20 mph (32 kmh) and hold the close button down for a few seconds: the passengers are protected from weather by the fully insulated fabric of the soft top.



MASERATI  
SPORTS CARS

# BEYOND COMFORT

Being at one with the landscape makes travel a pure delight.





# Everyday enjoyment

*Designed for four adults.*

The designers of the Maserati GranTurismo Convertible equipped it with seats which deliver nothing less than peerless comfort and quality, paying special attention to the rear passengers, who will experience an uncompromised environment not typically found in open-top models.

## **Rear Seats**

The rear passengers feel the difference immediately upon entering the car. From the automatic illumination, which provides a welcoming light from two cleverly-located rear lamps to the individual rear seats, with large seating surfaces and the same sporting profile as the front seats. The GranTurismo Convertible rear passenger compartment is ideally suited to seat two adults in complete comfort.

The attention to detail for the rear passengers extends to the standard storage compartment, ventilation controls as well as two full-sized cup holders matching those in the front. The rear seat comfort is enhanced by a relaxed, 22° rear seatback angle, giving the rear passengers a very comfortable seating posture unlike other convertibles with upright seat backs.



## Front Seats

With driver 10-way electrically-adjustable seats with driver memory function and power lumbar support (8-way electronically-adjustable passenger seat), the sport seats of the Maserati GranTurismo Convertible have a vast array of adjustments to make the driver and passenger uniquely comfortable. Equipped with a standard Comfort Package, both front seats are heated and the electrically-adjustable steering wheel automatically raises and lowers when the driver's door is opened to provide easy access. The seat and cushion is sporty and designed to support the torso and legs comfortably but securely during high speed cornering.

Thanks to the easy entry system on both the driver and passenger sides, the front seats move forward automatically to give easy access to the rear seats. And once the driver is seated, the driving pleasure begins by grasping a 14.8 in (375 mm) small-diameter, three-spoke, leather sport steering wheel.



EUROPEAN MODEL SHOWN. MASERATI GRANTURISMO CONVERTIBLE SHOWN WITH MARRONE CORNIOLE LEATHER AND ROSEWOOD. OPTIONAL WOOD AND LEATHER STEERING WHEEL.

# Daily usability

## Features

### Windstop

When driving with just one passenger, the sound, performance and fluid handling of the Maserati GranTurismo Convertible can be enjoyed in exceptional comfort thanks to an optional windstop developed specifically for this model.

The windstop, which is wind tunnel tested, reduces the flow of air inside the passenger compartment when driving with the top down. With the windstop installed, the air flow from the rear is reduced by 70% while the air speed inside the compartment is reduced by 50% all resulting in more comfortable and less windy conditions.

### Climate Control System

The automatic dual-zone climate control is designed to maintain ideal conditions inside the cabin by automatically and quietly adjusting the interior temperature and ventilation intensity in relation to outdoor temperature, sunlight and air humidity.

The fully electronic controls allow the driver and passenger to individually set their preferred temperatures over a range from 61° F (16° C) to a maximum of 90° F (32° C), while the airflow distribution also maintains the climate in the rear seat area through two vents located on the center console.



## ***Maserati MultiMedia System***

The GranTurismo Convertible audio and multimedia systems are each displayed on a 7-inch monitor —from the CD player, to satellite-based navigation system, radio and on-board computer. At the heart of the system is a 30GB hard drive which can store up to 180 hours of music either copied directly from CD or downloaded from your MP3 player via the USB port located in the passenger side glove compartment.

The simple and intuitive controls are thoughtfully positioned at the center of the dashboard while the main functions can be controlled without taking your hands off the steering wheel, thanks to the multi-function buttons. As an additional safety feature, the audio system, navigation and phone can all be controlled via voice commands.

The Maserati GranTurismo Convertible also includes a standard iPod interface, allowing music control and track information to be displayed.

## ***Bose® Surround Sound System***

With twelve premium quality Bose® audio speakers carefully integrated into car's interior styling in close collaboration with the Maserati development team, this Bose® Surround Sound System is capable of satisfying even the most demanding audiophiles.

The low-frequency subwoofers are both powerful and precise, while the higher frequencies, which are generally the most difficult audio range to reproduce in a moving car, are crystal clear, thanks to dedicated mid-range and tweeter speakers of the very highest quality. A highly effective AudioPilot system maintains unwavering sound quality in all driving conditions by compensating for car noise, the road noise and even overcoming the challenge of top-down driving conditions, the GranTurismo Convertible's acoustics are reminiscent of a concert hall.

# DESIGN MEETS TECHNOLOGY

Refined technology and balanced handling  
to satisfy the most demanding driver.





Information Provided by:  
**DEALER**  
A PROCESS

# Unrivalled *technology*

## ***Aerodynamic Efficiency***

The aerodynamics and styling of the car have been developed in close coordination to minimize the airflow disturbances typical of a cabriolet. The aerodynamic coefficient of drag (Cd) has been reduced to 0.35 with the top up, and 0.39 with top down—exceptional values for cars of this type.

This has been achieved thanks to the special design of the undercarriage (including the aluminum structure and engine panels) and careful design of the top to ensure that it does not compromise efficiency, even at high speeds. And of course, the overall design of the body has been specified to minimize drag and maximize downforce.

## ***Weight Distribution***

The critical factor which makes the Maserati GranTurismo Convertible fun to drive, responsive to each of the driver commands and totally enjoyable, is its balanced weight distribution. With the top up, 49% of the car's weight is carried by the front wheels and 51% by the rear wheels (48%/52% with the top down)—the ideal layout for handling and control.

This has been achieved by positioning the engine behind the centerline of the front wheels, translating everyday driving into a fluid and dynamic experience. The ideal weight balance also improves traction under acceleration (particularly on low grip surfaces) and overall road holding. It also results in exceptionally stable and balanced performance even during very spirited driving.

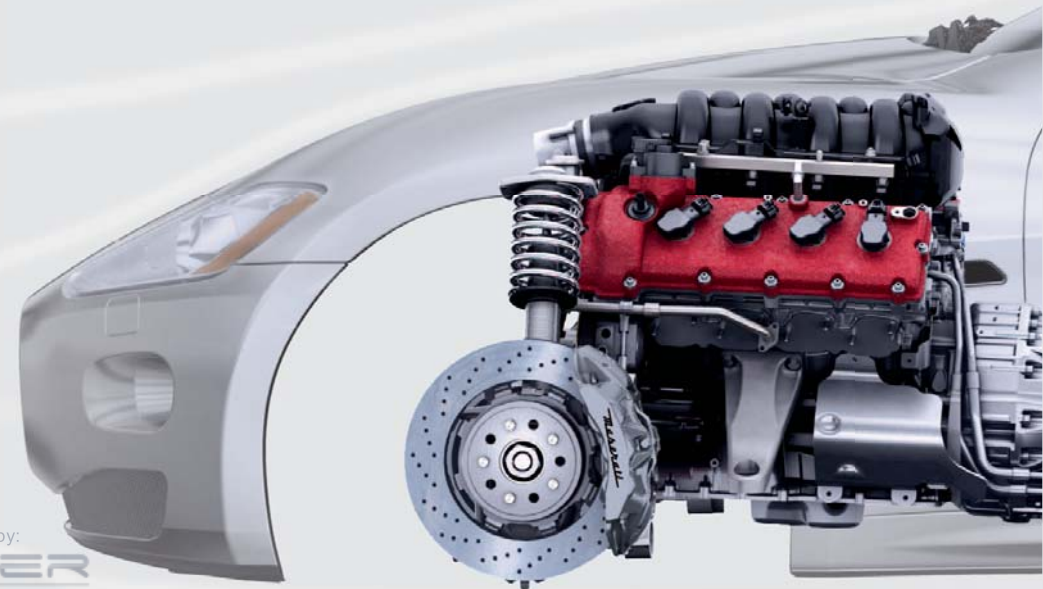



The unique balance of the GranTurismo Convertible is complimented by the 6-speed automatic transmission which is integrated into the engine block and incorporates a two-section driveshaft which delivers torque to the rear wheels via a standard limited slip differential to significantly reduce loss of traction while accelerating.

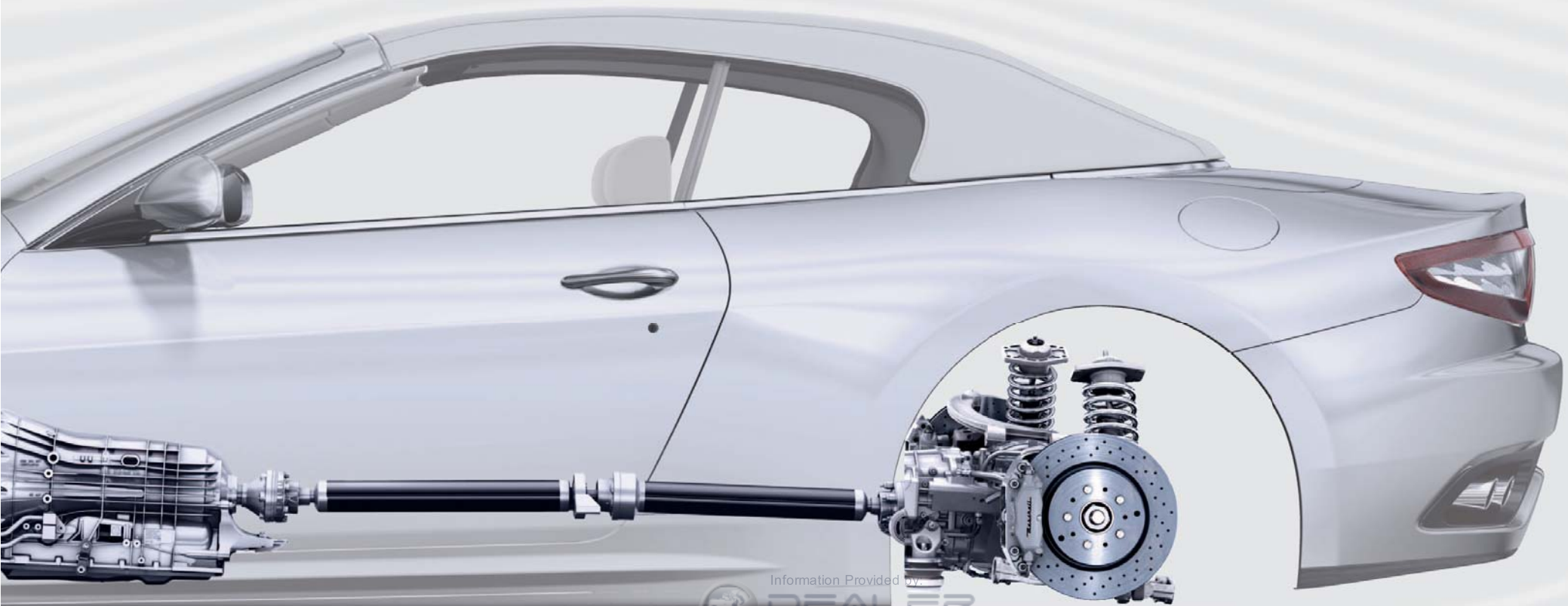

## ***Body***

The body structure is primarily comprised of high-strength steel, with the hood and bumper reinforcements constructed aluminum. The rear deck lid is produced from a thermoset plastic material which not only reduces its weight and is more resistant to minor damage than other materials and also gave the Maserati designers broad design freedom in creating its shape.

The new unibody was developed as the result of thousands of hours of computer simulation and an equal amount of testing. The result in terms of handling has to be experienced to be believed. The stiffness of the new body has set a new industry benchmark by boasting a torsional rigidity frequency of 27.2 Hz which is an indication of how resistant the overall structure is to twisting under load. This strength contributes to the very precise handling and is the basis for the overall dynamic performance of the GranTurismo Convertible.

And yet the car is a mere 221 lbs heavier than the GranTurismo coupe, so that the Maserati GranTurismo Convertible delivers the exceptional driving performance found in the Maserati coupe.

## ***Suspension***

The Maserati GranTurismo Convertible features aluminum gas shock absorbers equipped with the Skyhook Damping System which automatically selects the best damping rate to suit the dynamic conditions, improving the absorption of road irregularities while delivering the highest level of comfort.

The Skyhook system utilizes acceleration sensors which measure the movements of each wheel and the car body; and processes this information to interpret the driving and road surface conditions and immediately adjust the damper settings. The driver is still in control of the car's dynamics, which can be set to their own driving style via Normal and Sport modes. The first mode is characterized by softer damping for the greatest comfort, while the Sport mode is more controlled with reduced roll and load transfer.

The dynamic performance of the Maserati GranTurismo Convertible is assisted by the Maserati Stability Program (MSP), specially developed by Maserati to optimize driving dynamics and help improve safety. The system is based on a set of sensors which measure any deviations from the car's ideal dynamic behavior and act on both the brakes and engine performance to help regain directional stability.

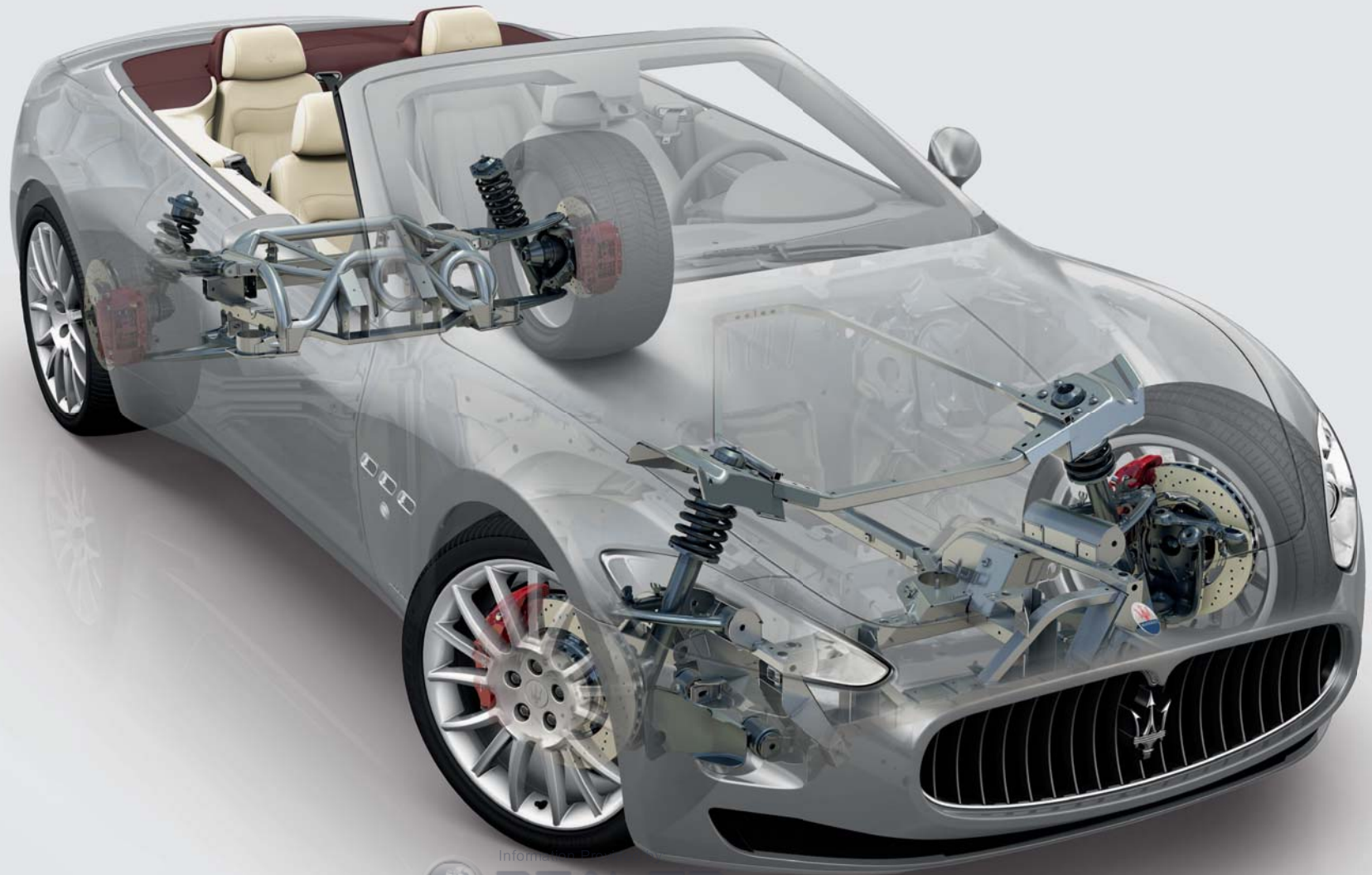



## **Braking System**

The Maserati GranTurismo Convertible is equipped with a high performance braking system employing dual-cast technology for the front brakes, a system developed in collaboration with Brembo. The disk's external braking surface is made in cast iron, while the hub is in aluminum. This solution combines the benefits of a larger disc for greater braking and cast iron's excellent performance at high temperatures while reducing the weight via the use of light aluminum.

The braking system has two circuits, with four ventilated and perforated discs. The front axle mounts monobloc aluminum callipers (more resistant to deformation than traditional two-piece callipers) with six pistons of different diameters and dual-cast discs measuring 14.2 in x 1.26 in (360 mm x 32 mm), while the rear axle has aluminum callipers with four pistons of different diameters and 13 in x 1.1 in (330 mm x 28 mm) cast iron discs.

The ABS system integrates an improved Electronic Brake Force Distribution system for improved braking between the front and rear wheels. The Maserati GranTurismo Convertible offers impressive performance in its brakes' capabilities and in their resistance to fade under intense use: the car boasts a stopping distance of just 114 feet from 60 mph to 0 mph (35 m from 60 km/h to 0), with an exceptionally high average deceleration rate of 1.24 g.

To improve uphill starts, the transmission employs a Hill Holder system, which is designed to keep the vehicle braked for a few seconds after the brake pedal is released on uphill slopes, thus enabling the driver to shift over to the accelerator pedal without the vehicle moving back.

The Maserati GranTurismo Convertible is equipped with a convenient and simple electronic parking brake, which is automatically engaged when the car is in Park and the ignition is shut off.

The car also features the Hydraulic Brake Assist System—a first for Maserati which recognizes panic situations by analyzing a combination of parameters such as the power brake pressure gradient, the wheel speed and illumination of the third stop light. The system monitors these parameters and takes over from the driver in activating the brake system at full power to ensure that full braking force is used under these conditions.





## Engine

The heart of the Maserati GranTurismo Convertible is the most powerful of Maserati's V8 engines; this version features a displacement of 4.7 liters and power delivery of 433 bhp at 7,000 rpm, with maximum torque 361 ft-lb at 4,750 rpm. The engine cylinder bank is designed with an angle of 90° with valve timing actuated by two chain-driven overhead camshafts per bank with four valves per cylinder controlled by hydraulic tappets. The intake side camshafts are fitted with a low pressure continuous phase timing variator, which changes the valve opening process for optimal performance in as little as 0.15 seconds, to increase engine response.

The timing chain design also makes the engine exceptionally reliable and quiet, with very low friction levels for reduced fuel consumption, as well as the capability for precision timing reflected in excellent cylinder filling capacity yielding top performance.

The Maserati V-8 employs a wet sump oil lubrication system, with an integral oil sump and high-performance pump to circulate and pressurize engine oil. This configuration was chosen to significantly reduce engine noise and improve passenger comfort.

82% of the engine's torque is available from a low 2,500 rpm, delivering exceptional pickup even in higher gears, so that overtaking is safer and overall driving is more enjoyable and sporty on challenging sections. To satisfy ever-increasing exhaust gas emission regulations, the Maserati GranTurismo Convertible utilizes a metal matrix catalyst system to achieve the U.S. LEV2 (Low Emission Vehicle) rating—without sacrificing performance.

Information Provided by:



## ***Maserati Sport Exhaust System***

The Maserati GranTurismo Convertible's exhaust is controlled by integrated pneumatic valves which are closed in Normal mode to ensure a comfortable, discreet sound level. Pressing the Sport button not only sets a number of car parameters but also opens the exhaust valves, thus enabling the engine to deliver maximum power with a stunning sound which is even more exciting with the top down.

The exhaust valve bypass is controlled so that it only opens at over 3,000 rpm, giving the car two distinct driving personalities: discrete and comfortable at low engine speeds, responsive and powerful at high revs with an unforgettable sound.

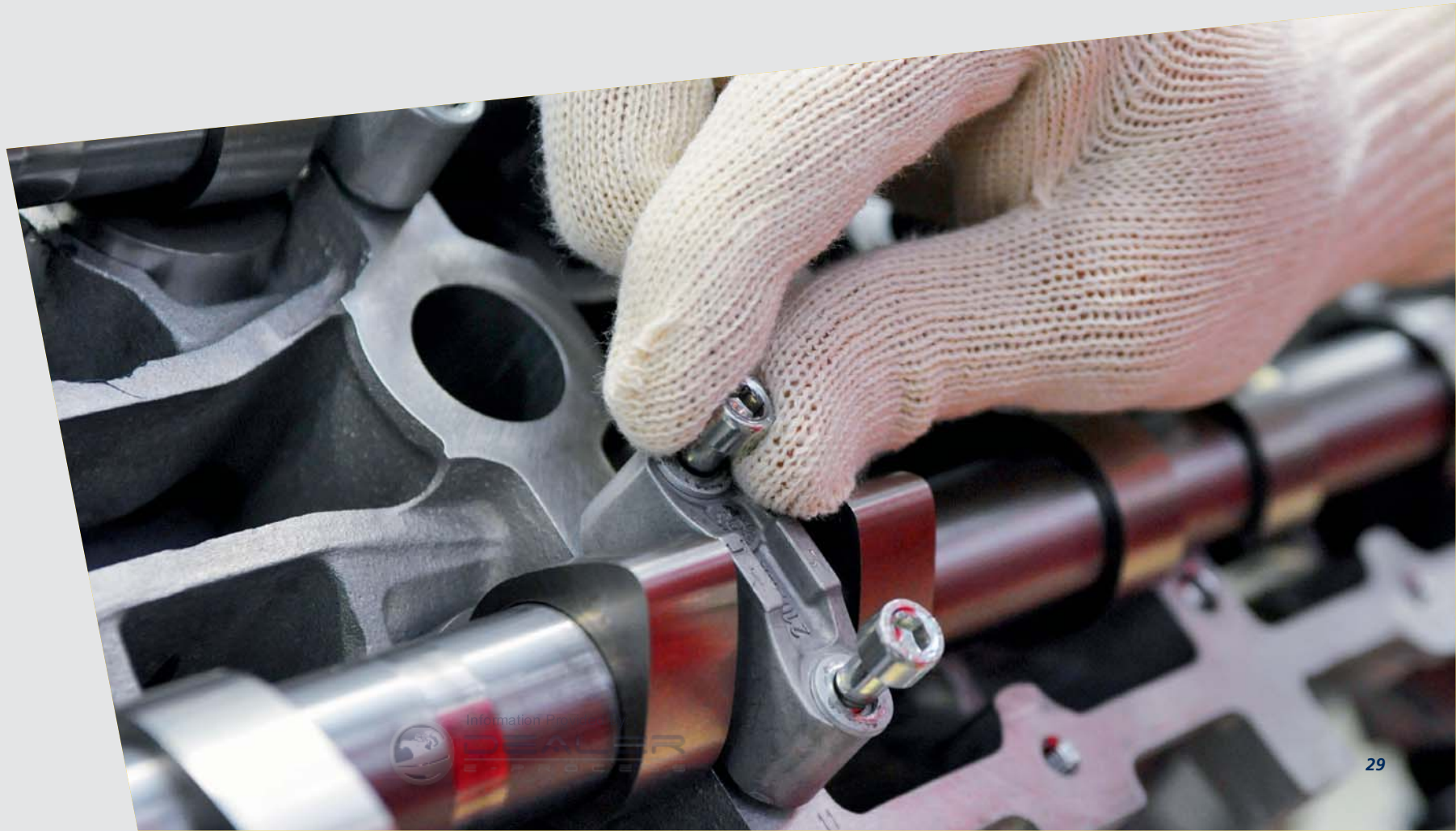

## ***6-Speed Automatic Transmission***

The Maserati GranTurismo Convertible combines a ZF 6-speed automatic gearbox with the 4.7 L engine—a combination which is compelling for the most demanding drivers with its response to the accelerator, while still providing smooth and fluid gear changes in the interest of passenger comfort.

The new hydraulic gearbox enhances the performance of the Maserati V8 engine, especially at low and medium revs, without sacrificing performance at high engine speeds, so that gear changes are genuinely those of a sports car in Manual-Sport mode. The driver can choose from four different driving modes.

### *Auto Normal Mode*

When driving normally (low cornering loads) the shifting performance is tuned to maximize comfort. Upshifts are performed as early as possible to achieve the lowest level of sound from the engine. Gear changes are actuated smoothly and at the most refined level.

When the driving style is recognized to be more sporty, gear shifts are automatically adjusted to occur at higher engine speeds, reducing the number of shifts and ensuring maximum power delivery.



Information Provided by:



### Auto Sport Mode

In a normal driving style without high lateral and/or longitudinal acceleration, the gear box downshifts one gear with respect to the Auto Normal mode, making the transmission more sporty with the characteristic sports car engine sound.

During sporty driving, the gear changes are shifted at even higher engine speeds and the downshift requests due to braking are calibrated to select the lower gear before entering a corner in order to provide maximum control entering the curve and engine torque exiting the curve. This is the ideal setup for challenging roads.

### Auto ICE Mode

When the driver requests the ICE mode, Sport mode is automatically deactivated and the stability program (MSP) restored; first gear is not engaged to reduce the maximum wheel torque and gear changes are performed in a range from 3,000 to 4,000 rpm to help maximize available traction.

### Manual Mode

When the gear lever is shifted from D to the +/- selector track, gears are set directly by the driver in sequence using either the gear shift lever or paddle shifters on the steering column.

Using the gear shift lever is very intuitive: pulling the lever back upshifts, while pushing it forwards downshifts, which follows the motion of the body caused by acceleration and braking. The driver can at any time change to using the steering wheel paddles (by leaving the gear lever in the "+"/"- track). The steering wheel paddles adopted by Maserati differ from other competitive systems via their ergonomic position (attached to the steering column) which makes them immediately available at all times and makes them a fixed reference—a safety feature in emergencies; using the gear shift paddles allows the driver to keep both hands on the wheel. Gearshifts are made with a simple flick of the fingers, which ensures greater safety, particularly on very curvy roads, but also increase greater driving enjoyment.



In order to ensure proper reliability, Manual mode includes automatic upshifts at the maximum permitted engine speed and automatic downshifts to avoid "under-speed." The exception is fifth gear, in which the gearshift must be requested by the driver, both to maintain a sporty driving experience and to provide maximum performance.

An electronic kick-down can be activated at any time by flooring the accelerator in Auto mode. In Manual mode this function has been inhibited to give the driver maximum freedom in selecting specific gear ratios.



EUROPEAN MODEL SHOWN.

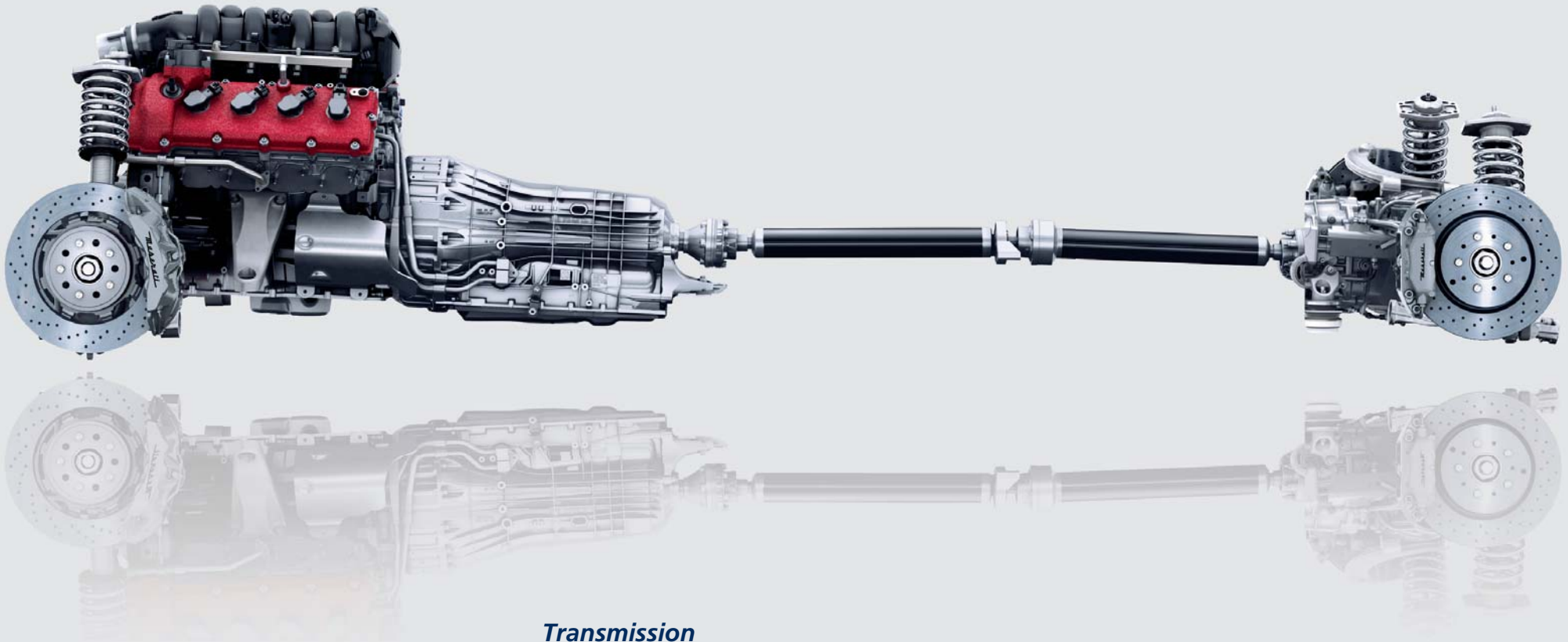

### ***Transmission***

The lay-out of the transmission is completed with the 6-speed automatic transmission in the front, integrated with the engine, and drive shaft divided into two sections which transmits power to the wheels through a limited-slip differential.

Steering responsiveness and precision also contribute to driving pleasure, comfort and safety, as well as to the sensation felt by the driver. The electronic power steering system ensures that its action is always calibrated to the vehicle speed, so that there is both a feeling of stability when driving at high speeds and a light and comfortable feel when maneuvering at lower speeds.

# ***FEEL PROTECTED***

Performance and safety go hand in hand as Maserati strives to produce cars with a high degree of safety engineering.





Information Provided by  
**DEALER**  
E-PROCESS

# Active *safety*

## ***Suspension Design***

The design of the suspension architecture, including the shape and angles of the four-wheel independent control arms is an art form for Maserati. The independent suspension system installed on the Maserati GranTurismo Convertible is remarkable in its precision, rigidity and motion range, all of which contribute to high handling limits and superb road performance. Further enhanced with standard Skyhook active variable damping system, the Maserati suspension is designed to instantly and continuously adjust the damping levels to the road conditions to retain its sharp handling character while allowing for a smooth and controlled ride quality.

## ***Adaptive Headlamps***

The Maserati GranTurismo Convertible features self-leveling Bi-Xenon gas discharge headlights for the brightest illumination. The Bi-Xenon headlights are enhanced further by the new Adaptive Light Control system, a mechanism that makes the headlights turn in the direction of the car when driving around curves. This improves illumination of the road and surrounding areas, and is therefore an important safety feature when travelling at night on winding roads. While the headlights are on, an electronic control unit monitors the steering wheel and its angle, as well as the car's speed. With this information the headlights activate special electric motors that rotate the light cones through angles of up to 15° on the inside light and 7.5° on the outside during cornering. For safety reasons the system only works at speeds over 3 mph, the rotation angle becomes smaller between 56 and 75 mph and deactivates above 75 mph. The fog lights are separate units that are integrated into the front bumper, and provide a particularly broad beam. The rear light units also feature LEDs. Some key advantages of LEDs are they illuminate quicker than ordinary light bulbs, are brighter, last longer, and use less energy.

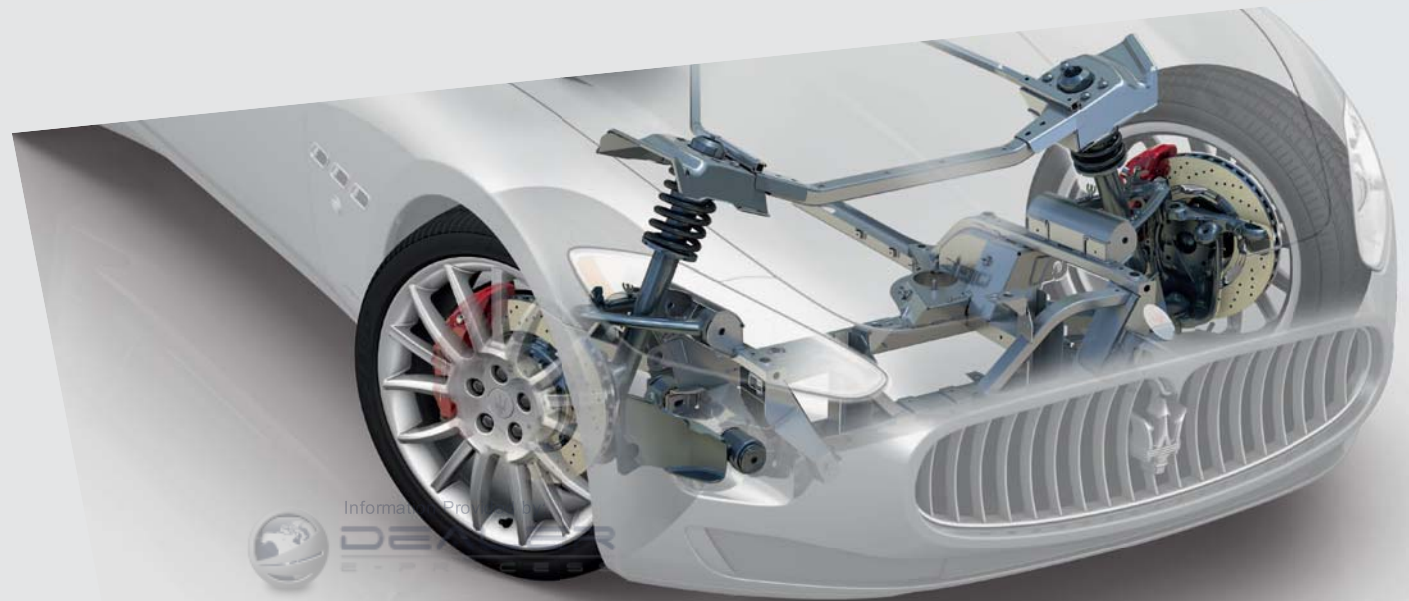

## ***Maserati Stability Program (MSP)***

The Maserati Stability Program (MSP), developed exclusively by Maserati, encompasses a series of electronic systems that are designed to optimize the car's dynamics and safety capabilities on the road. The system has a series of sensors that can detect anomalies in the dynamic behavior of the car and, by using the brakes and the engine the system automatically helps to stabilize the car.

The MSP system is designed to:

- Recognize the onset of skidding and helps stabilize the car in milliseconds;
- Help prevent the wheels from locking under braking (ABS);
- Distribute the braking force between the front and rear axles to help maximize braking force (EBD);
- To help prevent the drive wheels from spinning on low grip surfaces (ASR);
- To help prevent the drive wheels from locking when down shifting on low-grip surfaces (MSR).

## ***Maserati Standard Limited Slip Differential***

Derived from racing, Maserati equips the GranTurismo Convertible with a standard Limited Slip Differential which helps maximize available traction under power. A Limited Slip Differential overcomes the tendency of a normal open differential to send all torque to one wheel with low grip—creating wheel spin. The Limited Slip Differential effectively locks the two rear wheels together and delivers power to each. The result is maximum acceleration—in both straight line driving as well as in cornering.



With the EPB (Electronic Parking Brake) on the new Maserati GranTurismo, you can apply the parking brake easily by using an electronic control on the center console rather than a traditional mechanical lever. Aside from replacing the traditional handbrake, the EPB also has a dynamic safety function. If necessary, it can be used when the car is moving: the system, communicating with the stability control (MSP), acts on all four wheels to obtain an immediate braking action (deceleration of 0.5 g), without loss in stability, until the control is released (to be used in emergency situation only or when stopping the car with the brake pedal is not possible).

Quick, precise steering control helps improve comfort and safety on-board the Maserati GranTurismo and also provides an enjoyable ride. By using an electronic variable system, the action of the power steering is adapted to the speed and road conditions, giving the driver a true feel for the road both at high speeds and during low speed maneuvering. The Maserati GranTurismo Convertible is equipped with standard rear parking sensors integrated into the rear bumper which, together with the (optional) front sensors, helps facilitate maneuvering in restricted spaces. The instrument panel also shows color-coded symbols indicating distances to obstacles.







Through a set of dedicated sensors, the standard Tire Pressure Monitoring System (TPMS) is designed to check the tire pressure continuously. The system displays the tire pressures on the instrument cluster and warns the driver if they drop below a minimum level or if there is a puncture. To make hill starts easier, the Maserati GranTurismo has a Hill Holder, a device which, on inclines greater than 12°, keeps the vehicle braked for just over one second, so the driver can move their foot from the brake pedal to the accelerator pedal without the car rolling back.

# Passive safety

The load-bearing body structure helps enhance the safety of the new Maserati GranTurismo Convertible; furthermore, the application of the latest design technologies makes it possible to optimize the weight balance and performance. The structural part of the body is made of steel, the hood and front strut of the bumper are made of aluminum, while the trunk lid, made using Sheet Molding Compound technology, helps keep the weight of the car down.

## ***Air Bags***

The six air bag system on the Maserati GranTurismo Convertible has four individual sensors in the front and sides of the car and on a control unit located near the center console. The Maserati GranTurismo Convertible uses a new generation of dual stage airbags for the driver and front passenger. The latter is protected by airbags which adapt to the passenger's size and stature. Two side air bags are integrated in the front seats and two side window air bags are integrated in the door panels, designed to help provide protection for front seat passengers in the case of certain side impacts.



### ***Telescopic Roll Bar***

The automatic telescopic roll bar system is located behind the rear seats and remains out of sight, covered by the tonneau cover, until activated with a response time of less than 190 milliseconds. The airbag ECU is responsible for detecting and responding to dangerous situations.

### ***Seat Belts with Pretensioners***

Both the front and rear seatbelts have electronically-controlled pretensioners and load limiters of the most modern type. The front and rear safety belts are electronically-controlled and equipped with pyrotechnic pretensioners and load limiters. The system communicates with a sensor which evaluates the severity of a collision and, depending on its calculations, optimally inflates the airbags; it also takes into account the status (fastened/unfastened) of the seatbelts.



# INTERIOR HARMONY

A perfect balance of beautiful design, exceptional materials and myriad color combinations to satisfy the most refined tastes.





# Interior *design*

A uniquely sophisticated combination of modernity, elegance, traditional craftsmanship, sportiness and comfort: whoever travels in the Maserati GranTurismo Convertible, experiences only the best.

Materials worked with precision and skill by leather and wood craftsmen; tradition and design perfection underlie the form and substance of the Maserati's interior.

The first impression to strike the eye is the dashboard, which is laid out horizontally and is characterized by the signature Maserati V-shaped design running across its entire width.



The controls are distributed to give the driver the feeling of total control: with major dynamic functions controlled by driver side buttons, while the most commonly used multimedia controls can be operated with the buttons on the steering wheel and displayed on the 7-inch screen of the Maserati MultiMedia System mounted at the center of the dashboard, in a raised position for improved visibility.

The attention to detail is demonstrated by a number of features such as the subtle chrome inlay that elegantly decorates the buttons on the dashboard and steering wheel, the Trident logo hand-crafted on the seat headrests, the Alcantara® trim lining the back of the gear shift paddles, as well as the visible stitching of the front and rear armrests.



# Materials and *custom options*

The primary material used in the Maserati GranTurismo Convertible interior is Poltrona Frau™ leather, a true expression of Italian craftsmanship, with regard to both the rich quality of the raw material as well as the traditional craftsmanship used in its fabrication. The leathers used for Maserati are meticulously selected to provide the best quality, and most pleasurable feel of this natural material.

The refined processes that this material undergoes adds durability, strength and practicality to its attractive appearance and quality. The result: a soft, welcoming material in the winter which is nevertheless fresh and breathable in the summer delivering a beautiful sensation at all times. The leather is available in ten colors to offer the greatest creative freedom with compelling color combinations for the seats, dashboard, tonneau cover, steering wheel and gear lever knob, all of which can be contrasted with the colors of the thread, carpets and top interior fabric.

The design elements of the dashboard and the door panels are other areas where further personalization is offered: the standard trim is comprised of dark gray chrome and a selection of standard precious woods which create the warm and elegant look of a classic Italian automobile, as well as darker technical trim colors for a more sporting, exclusively-styled interior.

## ***New Wood Types***

Maserati owners are well aware of the significant care taken in selecting elegant and welcoming materials like Carbalho wood, with its characteristic sectioned patterns, and Moonwood with its linear grains, are new additions to the already rich range of options.





Carbalho in particular is a very unique wood from Brazil (Carbalho Brasileiro) characterized by medium density and high porosity. Thanks to its three-dimensional effect, Carbalho offers a unique pattern in every piece of wood. It is this precious and prized characteristic that gives each car its own special signature look—each and every vehicle has its own signature wood pattern. By contrast, Moonwood, is a multi-layer composite wood with a light color and pinkish grain, which suits the interior of the car exceptionally. The Maserati GranTurismo Convertible also delivers a beautiful surrounding for the climate control system and LCD screens Dark gray chrome, a synthesis of the warm and sporty concepts underlying the design as a whole, which combines anthracite grey with warm highlights.

Even the smallest details, such as these, make a significant contribution to the overall appearance. This is why even the carpets can be customized with colored borders available in no less than seven colors: black, blue, bordeaux, gray, brown, red and sand. Every Maserati GranTurismo Convertible will be a unique statement of design.

# Accessories

## Luggage

The Maserati GranTurismo Convertible is accompanied by the launch of a new custom-fit set of luggage, available in both beautiful leather and leather/fabric combinations. The luggage set is available in blue, black; red, Testa di Moro, beige and a seasonal color scheme which will change each year in line with design trends.

The basic luggage set designed to fit perfectly into the GranTurismo Convertible, is composed of men's and women's roller bags, and two beauty cases. There is also a case designed to be load onto the rear seats and held in place by dedicated straps.



Information Provided by:



## **Luggage Straps**

Maserati has developed optional luggage straps in a technical fabric with customized black leather detailing enabling the rear seats to be used for safely storing objects and luggage weighing up to 22 lb (10 kg).

## **Ashtray**

To make best use of the available space in the car's interior, Maserati placed the soft top switch conveniently on the center console allowing easy operation of the soft top. For smokers, an optional ashtray is available fitting into one of the four cup holders. It has a beautifully machined natural aluminum body and a polished lid to match perfectly the chrome-plating of the controls around it.



# Bodywork



*Bianco Eldorado*



*Grigio Touring*



*Grigio Alfieri*



*Grigio Granito*



*Blu Nettuno*



*Blu Oceano*



*Bordeaux*



*Nero Carbonio*



*Nero*

## Paint colors



*Bianco Fuji*



*Giallo Granturismo*



*Blu Mediterraneo*



*Matte Bianco Fuji*



*Matte Blu Mediterraneo*



*Rosso Mondiale*



*Grigio Nuvolari*



*Argento Luna*



*Matte Grigio Granito*

*Special **paints***



*Matte **colors***

# Interior



*Pearl Beige*



*Avorio*



*Sabbia*



*Cuoio*



*Marrone Corniola*



*Grigio Medio*



*Blu Profondità*



*Rosso Corallo*



*Bordeaux*



*Nero*

## Leather **colors**



*Rosewood*



*Walnut Briarwood*



*Moonwood*



*Blu Laque*



*Black Piano*



*Wengè Polished*



*Carbalho*



*Padouk*



*Dark Chrome*

*Internal **wood trim***

*Interior **finishes***

# Soft top



*Nero*



*Beige*



*Java*



*Cioccolato*



*Burgundy*



*Grigio Beluga*



*Grigio Titanio*



*Blu*



*Nero*

*Internal* **headlining**



*External* **fabric**

DEALER  
E-PROCESS



# Wheels and Brakes



Alloy wheels Birdcage design  
(8,5J x 20" front; 10,5J x 20" rear)  
(Standard)



Alloy wheels Trident design  
(8,5J x 20" front; 10,5J x 20" rear)



Alloy wheels Neptune design  
(8,5J x 20" front; 10,5J x 20" rear)



Brake calipers painted Nero



Brake calipers painted Argento



Alloy wheels Birdcage design  
Grigio Mercury  
(8,5J x 20" front; 10,5J x 20" rear)



Alloy wheels Trident design  
Grigio Mercury  
(8,5J x 20" front; 10,5J x 20" rear)



Alloy wheels Neptune design  
Grigio Mercury  
(8,5J x 20" front; 10,5J x 20" rear)



Brake calipers painted Rosso  
(Standard)



Brake calipers painted Blu



Brake calipers painted Giallo



Brake calipers painted Titanio

# Standard and **Optional** Equipment

● Standard  
○ Optional

## SAFETY

Bi-xenon headlights with headlight washing system	●
Adaptive headlights with rotating lamps for an active cornering illumination	●
Automatic headlamp activation	●
Front indicators integrated into the headlamps	●
Front and rear foglamps	●
Taillamps with high visibility LED lights	●
Automatically-dimming interior mirror	●
Automatically-dimming exterior mirrors	●
Air-bag system: dual stage front bags, side bags head-thorax	●
Front seat belts with pre-Tensioners and load limiters	●
Rear seat belts with pre-Tensioners	●
Child seat ISOFIX attachments, rear	●
Maserati Stability Program (MSP) includes: stability control (MSP), traction control (ASR), anti-lock braking system (ABS), electronic brake distribution (EBD), engine torque control (MSR)	●
Tire Pressure Monitoring System (TPMS)	●
Tire sealing compound	●
Telescopic roll-over protection system	●

## WHEELS AND CHASSIS

Light alloy wheels, 20" Birdcage design colored in silver (8,5J x 20" front; 10,5J x 20" rear)	●
Light alloy wheels, 20" Trident design colored in Grigio Mercury (8,5J x 20" front; 10,5J x 20" rear)	○
Light alloy wheels, 20" Trident design colored in silver (8,5J x 20" front; 10,5J x 20" rear)	○
Light alloy wheels, 20" Birdcage design colored in Grigio Mercury (8,5J x 20" front; 10,5J x 20 rear)	○

Light alloy wheels, 20" Neptune design colored in silver (8,5J x 20" front; 10,5J x 20" rear)	○
Light alloy wheels, 20" Neptune design colored in Grigio Mercury (8,5J x 20" front; 10,5J x 20" rear)	○
Skyhook—electronically variable active damping system	●
14.2 in (360 mm) drilled brake discs—front; 13.0 in (330 mm) drilled brake discs—rear	●
Power-assisted steering wheel, with speed sensitive features	●
Electronic Parking Brake (EPB)	●

## EXTERIOR EQUIPMENT

Metallic paintwork	
Special colors	
Bianco Fuji color—pearlescent white	
Matte colors	
Front grille with vertical and concave grille bars	
Chromeline exterior trim	
Door mirrors—electrically operated, folding and heated	
Side ornamental grilles	
Electric opening assist for trunk lid and doors	
Lightweight trunk lid construction, with remote key opening	
Maserati designation—rear	
Rear parking sensors	
Front parking sensors	
Exhaust—twin-dual tube tailpipes, in chrome plated stainless steel	
Car cover	
Fully automatic soft top	

## INTERIOR EQUIPMENT

Under door sills—Cabrio design	●
Instrument dials in Maserati Blu color with white graphics	●
Maserati clock design in center dashboard with chrome-plated trim	●
Three-spoke multifunction sport steering wheel	●
Power steering column tilt/telescopic with easy entry/exit function	●
Maserati "Active Shifting" (shift paddles)	●
Maserati "Active Shifting" (sport paddles—Trofeo design)	○
"SPORT" button for sport mode set-up	●
Front seats with high lateral support, electrically adjustable in height, depth, and backrest with "easy-entry" (the seat moves forward and backward automatically to facilitate the entry and exit of rear passenger). Lumbar support for driver included	●
Heated front seats	●
Driver's seat memory and lumbar support	●
Trident logo embossed on head restraints—front and rear	●
Folding front armrest with illuminated storage compartment	●
Fixed rear armrest integrated into the center console	●
Two individual full size cup holders—front and rear passengers	●
Lockable, illuminated glove compartment on passenger side dashboard	●
Storage compartment in center console—front and rear	●
Two air outlets—rear	●
Aluminum sport pedals	○
Windstop	○

## ELECTRONIC FEATURES

Electronic anti-theft system with immobilizer	<input checked="" type="checkbox"/>
Alarm system (perimeter and volumetric sensing, anti-lift device, electronic immobilizer)	<input checked="" type="checkbox"/>
Remote key (on/off alarm system, lock/unlock doors, unlock trunk lid)	<input checked="" type="checkbox"/>
Cruise control	<input checked="" type="checkbox"/>
HomeLink—Garage door opener	<input checked="" type="checkbox"/>
Dual zone automatic climate control with two rear air outlets in center console	<input checked="" type="checkbox"/>
Auto de-fogging sensor	<input checked="" type="checkbox"/>
Maserati MultiMedia System with 7-inch dashboard screen—includes navigation system, RDS tuner, single CD player, 30GB hard disc drive	<input checked="" type="checkbox"/>
Bluetooth® and USB port to upload audio files and MP3 files	<input checked="" type="checkbox"/>
iPod interface	<input checked="" type="checkbox"/>
Bose® Surround Sound System with 12 speakers	<input checked="" type="checkbox"/>
Rain sensor	<input type="checkbox"/>

## UPHOLSTERY AND TRIMS

Poltrona Frau™ leather upholstery	<input type="checkbox"/>
Poltrona Frau™ drilled leather for central seats areas	<input type="checkbox"/>
Dashboard and tonneau cover colored upon request	<input type="checkbox"/>
Dual interior color leather upholstery with additional stitching	<input type="checkbox"/>
Colored stitching upon request (excluding steering wheel and gear knob stitching)	<input type="checkbox"/>

Grigio Dark Chrome trim on selected interior details (dashboard, door and rear panel moldings, gear knob finishing, clima and LCD details)	<input checked="" type="radio"/>
Wengè wood trim on selected interior details (dashboard, door and rear panel moldings, gear knob finishing)	<input type="radio"/>
Rosewood trim on selected interior details (dashboard, door and rear panel moldings, gear knob finishing)	<input type="radio"/>
Walnut briarwood trim on selected interior details (dashboard, door and rear panel moldings, gear knob finishing)	<input type="radio"/>
Carvalho wood trim on selected interior details (dashboard, door and rear panel moldings, gear knob finishing)	<input type="radio"/>
Padouk trim on selected interior details (dashboard, door and rear panel moldings, gear knob finishing)	<input type="radio"/>
High gloss color for selected interior details in Black Piano and Blu Laque (dashboard, door and rear panel moldings, gear knob finishing)	<input type="radio"/>
Steering wheel and gear knob in colored leather	<input type="radio"/>
Wood steering wheel (Rosewood, Walnut briarwood, Wengè polished) and black leather	<input type="radio"/>
Wood steering wheel (Rosewood, Walnut briarwood, Wengè polished) and colored leather	<input type="radio"/>
Special range carpet piping upon request	<input type="radio"/>
Interior carpet color upon request	<input type="radio"/>
Black soft top exterior and headliner colored in black mesh	<input checked="" type="radio"/>
Black soft top exterior color with headliner interior (beige/grigio beluga/grey eliade material)	<input type="radio"/>
Colored soft top exterior with headliner interior (beige/grigio beluga/grey eliade material)	<input type="radio"/>

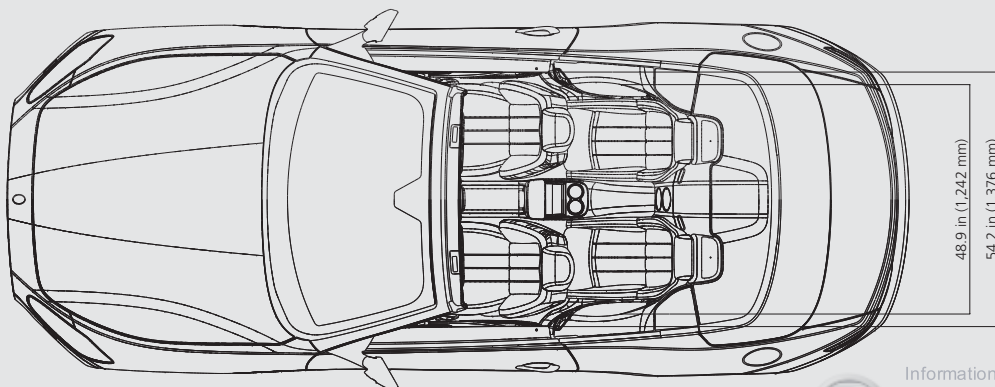
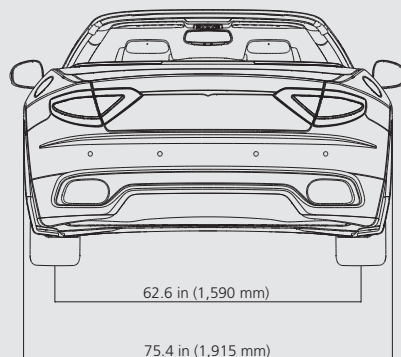
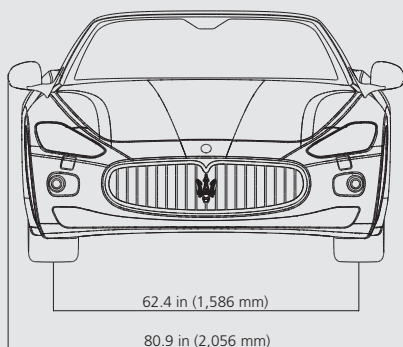
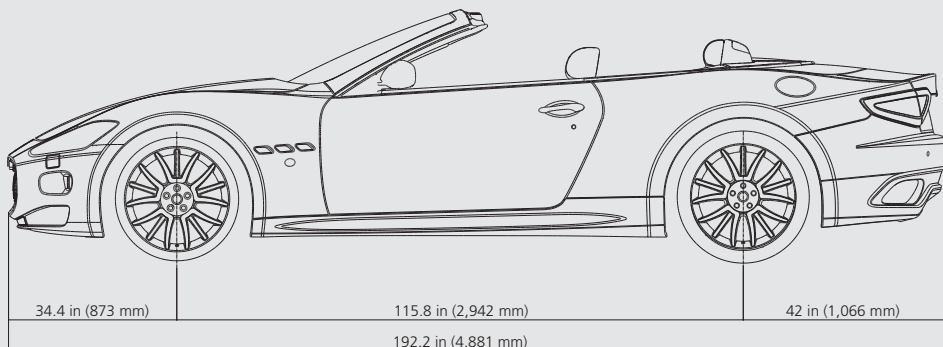

## ENGINE

• Engine	90° V8 4.7 L normally aspirated
• Bore and Stroke	3.7 in x 3.33 in (94mm x 85.5 mm)
• Compression ratio	11.25 : 1
• Maximum power output	433 hp (323 kW) at 7,600 rpm
• Maximum torque	361 lb-ft (490 Nm) at 4,750 rpm
• Maximum engine speed	7,600 rpm

## PERFORMANCE

• Top speed	176 mph (283 kmh)
• 0 to 60 mph acceleration	5.3 s
• ¼ Mile acceleration	13.2 s
• 60-0 mph braking distance	114.8 ft (35 m)
• Aerodynamic drag	0.35 (roof closed—same as the GranTurismo Coupe) 0.39 (roof open)
• Brakes	Brembo system Front: 14.2 in (360 mm) cross-drilled dual cast brake discs Rear: 13 in (330 mm) cross-drilled brake discs

## DIMENSIONS AND WEIGHTS

• Length	192.2 in (4881 mm)
• Width (excluding mirrors)	75.4 in (1915 mm)
• Width (including mirrors)	80.9 in (2056 mm)
• Height	54.3 in (1380 mm)
• Wheelbase	115.8 in (2942 mm)
• Front track	62.4 in (1,586 mm)
• Rear track	62.6 in (1,590 mm)
• Front overhang	34.4 in (873 mm)
• Rear overhang	42 in (1,066 mm)
• Curb weight	4,365 lbs (1,980 kg)
• Trunk capacity	6.1 cu-ft (173 l)
• Fuel tank capacity	19.8 gal (75 l)
• Weight distribution	49% front; 51% rear (top closed) 48% front; 52% rear (top open)
• Seating capacity	4 adults

## WHEELS AND TIRES

• Front alloy wheels	8.5J x 20"
• Rear alloy wheels	10.5J x 20"
• Front tires	245/35 ZR 20"
• Rear tires	285/35 ZR 20"

## MAINTENANCE AND WARRANTY

First service at 25,000 miles or after two year of the vehicle's life and subsequently every 25,000 miles or every two years. Refer to the owner's manual for full scheduled maintenance. Transferable four-year/50,000 miles new car warranty with 24/7 Roadside Assistance. Ask your Maserati dealer for more details.

# MASERATI WORLD

A world of competition, passion and services  
dedicated to those who love Maserati.

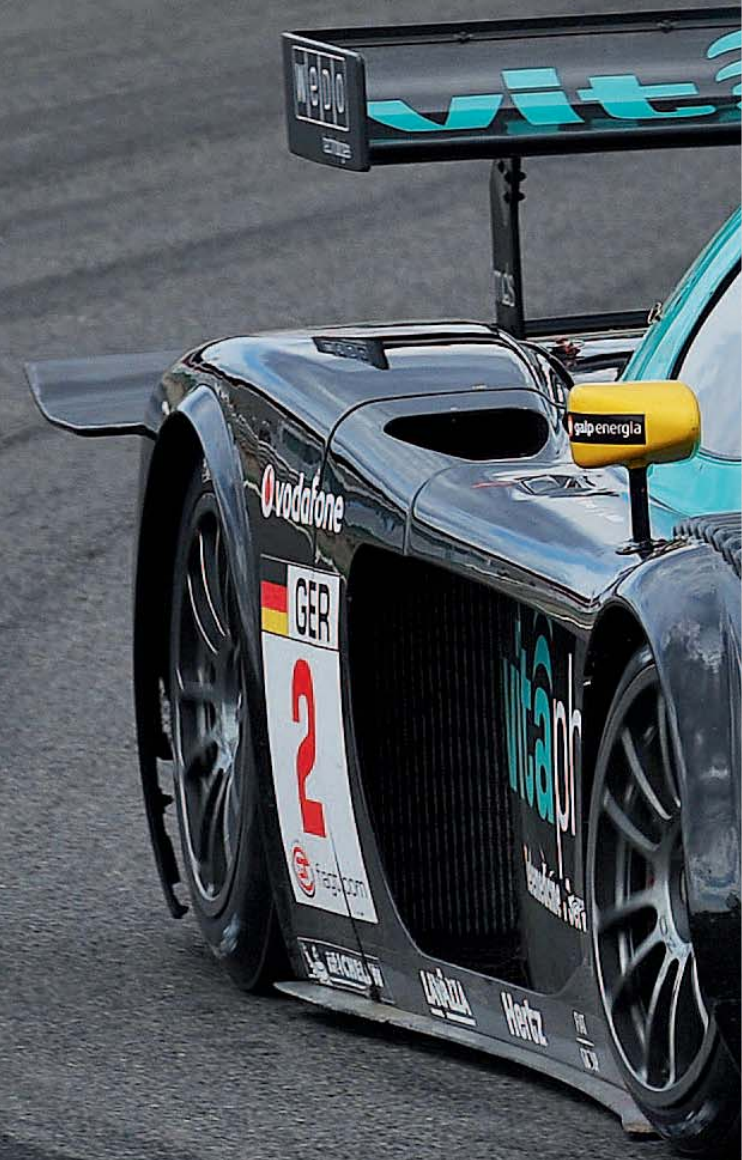





# Master Maserati *driving courses*

A unique opportunity that allows clients and potential customers to experience the thrill of being behind the wheel of Maserati models with the support of a highly professional staff and the latest equipment. The Master Maserati Driving Courses are a terrific way to experience the race track under a professional guidance. The courses are designed to teach how to properly handle a Maserati while still pushing and controlling this powerful sports car to its limit. The courses take place at the Varano de' Melegari Circuit, located near Parma, Italy (a few miles from the Maserati Headquarters), a circuit that puts technical skills to the test and is also equipped with special driving instruction features, under the technical direction of the former F1 driver Ivan Capelli and the constant supervision of a team of professional drivers.

## **Master GT**

A two-day all-inclusive package spent behind the wheel of the various Maserati models. A thrilling, intensive training course that introduces participants to a sequence of exciting dynamic driving. It includes driving sessions on the circuit with a variety of courses (apex technique with instructor in the car, acquisition and analysis of telemetry data, driving with pace-car) and practice controlling the car in different simulated road surface conditions (for example, quick direction changes, controlled skid and braking techniques).

## **Master High Performance**

An intensive one-day course, the Master High Performance program takes the racing-driving techniques studied in the Master GT course to their highest level. The course, designed to provide an extremely professional service and cover the latest techniques, allows participants to test-drive high performance Maseratis on the track through a highly specialized and personalized program combining driver's satisfaction and technique.



## **Master MC Trofeo**

The Master Maserati MC Trofeo is the ultimate expression of the sports driving concepts developed in the Master High Performance program. This course represents an unforgettable and thrilling experience with a highly professional team of instructors and gives you the chance to be part of the Maserati competition world and drive the cars competing in Europe in the Maserati Trofeo Championship.

**For more information and registration,** please contact your nearest authorized Maserati Dealer or Master Maserati Office at Tel: +39 0525 55 11 38 Fax: +39 0525 55 11 40  
Mail: [info@mastertg.it](mailto:info@mastertg.it)



# *The tailor-made services of the Maserati world*

## **Carefully Built and Meticulously Tested**

Each Maserati is built in the historic Maserati factory complex in Viale Ciro Menotti in Modena, Italy. Over the last several years the factory has been completely updated to help ensure the highest production standards and is now amongst the most advanced small series production facilities in the world, combining traditional hand-crafting techniques with cutting edge technology. Each new Maserati, after being thoroughly examined and tested in the engine running-in and diagnostic area where its torque and power output are verified, is put through its paces by our professional test-drivers.

## **Factory Delivery**

You've chosen your Maserati, its color scheme and its accessories. Now, at last, it's time to take delivery of your car. The thrill of getting the keys of a Maserati GranTurismo Convertible that has been tailored specifically to suit your own personal style is hard to match. And now you can experience that very special moment at the Maserati factory itself. Direct personal delivery at the Maserati factory will also include a tour of the production line where you will see first-hand just how Maserati are built.

For further details and to book your personal delivery, please contact your nearest authorized Maserati dealer.



Information Provided by  
**DEALER**  
IN PROCESS

### ***Four-Year Limited Warranty and Roadside Assistance***

Confident in its high performance automobiles, Maserati North America covers them with a transferable four-year/50,000 mile new car limited warranty. Because daily use includes the risk of road hazards, Maserati North America includes Maserati Roadside Assistance on all new Maserati vehicles sold in the USA and Canada throughout the new car limited warranty period.

Available 24/7 toll-free at +1 888 371 1802, the program provides transport to the nearest authorized Maserati dealership if the car cannot be made roadworthy by the responding technician. If overnight warranty repairs are necessary, limited rental reimbursement and travel assistance may also be provided through the program. Ask your local authorized Maserati dealer for more details.

### ***Certified Pre-Owned Extended Service Coverage***

Maserati Certified Pre-Owned Warranty coverage provides an additional two years or 50,000 miles to any balance of existing New-Car Warranty coverage that remains, for a total of six years or 100,000 miles. (Not currently available in Florida). In addition, each Certified Pre-Owned Maserati is covered with Maserati Roadside Assistance and your Maserati Certified Pre-Owned Warranty can be transferred to subsequent owners, representing added value to your purchase. All 2007 model year and newer vehicles originally imported by Maserati North America, Inc., serviced in accordance with Maserati factory guidelines and conforming to Maserati North America, Inc. and Maserati SpA enrollment and inspection qualifications are eligible to participate in the Certified Pre-Owned program. Every Certified Pre-Owned Maserati must pass an exhaustive test regimen performed exclusively by factory-trained technicians. For complete details of the terms and conditions, and eligible models, consult your nearest authorized Maserati dealer.



**MASERATI**  
**CERTIFIED PRE-OWNED**





### ***Maserati Web Site and Car Configurator***

To discover all the ways in which the Maserati GranTurismo Convertible can be personalized, we have created an innovative and unique car configurator. It has been developed to bring your Maserati GranTurismo Convertible to life by giving you the chance to personalize many of the vehicle's features. The system has been enhanced with "X-ray" software to make the experience all the more enjoyable and to see inside the car and appreciate all its interior technological elements. Create your own Maserati at [configurator.maserati.com](http://configurator.maserati.com) or to browse the entire Maserati range, the services on offer, or simply to see how the company's heritage blends perfectly with modern day performance, visit [maserati.us](http://maserati.us)

## Factory Tour

Discover how the Maserati cars are born, learn the secrets to their craftsmanship, fully understand their engineering and really become part of the Maserati family. The tour is by appointment only and reservations can be made at any Maserati dealership.

## The Maserati Experience

For those who truly wish to discover Modena, its culture, history and cuisine. The Maserati Experience program introduces you first hand to the Maserati world: Modena, with its works of art, its history and its fine cuisine. You can tailor your Maserati Experience to your personal taste by combining a variety of activities:

- Panini Museum and/or Stanguellini Car Museum visit;
- Guided tour of the town;
- Guided tour of a traditional balsamic vinegar establishment, with tasting;
- Guided tour of a winery, with tasting of local wines;
- Cooking school;
- Day at the "Modena Golf & Country Club;"...and much, much more.

For more information please contact us by writing to:

[maseratiexperience@maserati.com](mailto:maseratiexperience@maserati.com) or [drivemaserati@maseratiusa.com](mailto:drivemaserati@maseratiusa.com)



Information Provided by:  
**DEALER**  
E-PROCESS



### ***The Maserati Collection***

Now you can reflect your car's timeless style and elegance with a completely updated collection of clothing and accessories. The Maserati Collection, conceived and produced in line with the Maserati philosophy of excellence and fine design is available from all official Maserati Dealers, from the Maserati Store at the Maserati Headquarters in Modena and online at [maseratistore.com](http://maseratistore.com)

### ***Worldwide Maserati Club***

The owners of Maserati cars from every era can fully enjoy the pleasure of owning and driving a Trident sports car by taking part in a calendar of events exclusively for Maserati Club members. The Maserati Club provides the link between the past, present and future of the Modena constructor. The association is led by personalities who have made a fundamental contribution to the growth and promotion of Maserati in all eras, starting from the President, Maria Teresa de Filippis, the first woman F1 driver and today a proud supporter of the Trident. Becoming a Maserati Club member is simple, just like the joy of sharing a deep passion for Maserati cars.

*For more information, access [www.maseraticlub.com](http://www.maseraticlub.com)*



## ***Genuine Maserati Accessories***

Especially designed to fulfill widely different needs, Genuine Maserati accessories represent the perfect combination of design, functionality and quality, a characteristic that has always defined our brand.

The range of genuine accessories includes items designed to enhance the elegant and sporty appeal of Maserati models. Exterior variations include spoilers, front grills and colored brake calipers; interior finishing, such as branded carpet mat sets and under-door moldings; components linked to dynamic performance with a wide choice of alloy rims and handling kits. Other genuine accessories include car care cleaning kits, car covers, battery chargers as well as a full line of "MC Sport Line" exterior and interior accessories crafted from race inspired materials, carbon fiber and aluminum, emphasizing Maserati's sporting heritage.





©2010 Maserati North America. All rights reserved. The illustrations and texts contained in this brochure are based on the information available at the time of printing and do not contain a description of specific characteristics of the car by the Manufacturer. Some models, equipment and accessories may not be available or may only become available after the car's launch on the market. Maserati reserves the right to modify colors, designs and technical features at any time and without prior notice. Contact your authorized Maserati Dealer for further details.

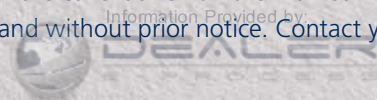



[WWW.MASERATI.US](http://WWW.MASERATI.US)

MASERATI NORTH AMERICA, INC. · 250 SYLVAN AVENUE · ENGLEWOOD CLIFFS, NJ 07632

1-877-MY MASERATI · [DRIVEMASERATI@MASERATIUSA.COM](mailto:DRIVEMASERATI@MASERATIUSA.COM)

