



▶ The 2008 Audi Q7





At home in the city. And in the country. For 2008, we've added a number of new ways to personalize your vehicle. Audi Q7 4.2 Premium shown.

Facing the future with supreme confidence.
Quality you can believe in.



Audi Q7 3.6 with optional equipment shown.

Performance. Design. Technology. Safety.

A profile in leadership.

Built with North America in mind, both the Audi Q7 3.6 and 4.2 have nonetheless become worldwide sensations. Consider the facts: An acclaimed interior. Commanding exterior. Your choice of a spirited V6 or a powerful V8, engines that remain at once torque-rich and fuel-efficient. With 280 hp and 350 hp respectively. Now add rally-proven and time-tested quattro® all-wheel drive. A host of active and passive safety features: Five-star ratings from NHTSA*. All the latest communication and entertainment tools. And then some. For example, Extended Leather and an Alcantara® headliner. In other words, the total package.

A package that lets you know in so many ways that the era of the brutish SUV is over. It's time for a new leader.



*Government star ratings are part of the National Highway Traffic Safety Administration's (NHTSA's) New Car Assessment Program (www.safercar.gov).

Audi Q7 4.2 Premium shown.



Assertive. Athletic. Authentic.

Absolute proof that the truth lies in the details.



There is a certain subtlety to the rear spoiler of the 2008 Audi Q7. The perfect ending to a roofline that Richard Williamson of *Scripps Howard* termed "stylishly windswept." From its bold, single-frame grille to its stylishly integrated taillights, a shape that belies, but never betrays, its size. You see, words like boxy, clunky and ham-fisted just aren't in our vocabulary.



It would have been far easier, and completely acceptable, to not integrate the taillights into the rear door. But the easy way isn't the Audi way. We prefer to stay true to the original design. And then find ways to make it happen. Such as adding lights at the bottom of the tailgate to ensure visibility when it's opened. And the beneficiary of such forethought? You.



A vehicle that corners as well as the Audi Q7 deserves nothing less than eyes that pierce through the night. Optional bi-xenon plus adaptive lights do more than illuminate the road, they show you what's around the bend. Factoring in variables such as speed, pitch, yaw and roll, the headlights corner with the vehicle. Add radar-enabled Audi side assist and adaptive cruise control as well as the camera-controlled interactivity of new Audi lane assist and you're both connected to the present as well as prepared for whatever lies ahead. Or coming up beside you.



New for 2008: More standard features that others offer only as options. If at all. Our goal is to make selecting your Audi Q7 almost as pleasurable as owning and driving it.

While the Web is a fine place to learn more about the Audi Q7, your dealer is the place to go to turn the car of your dreams into a reality.

Incorporating turn indicators into the side mirrors is more than a stylish flourish. Consider them a courtesy to your fellow motorists.



Audi Q7 4.2 Premium with optional accessories shown.

Take a seat. Any seat.

For 2008, third-row seating is standard on the 3.6 Premium and the 4.2 Premium. Yet whether seating seven, two, six, three or one, the Audi Q7 satisfies on any number of levels. A foursome bound for some serious rounds at the coast? Not a problem. A dream for those who opt for our Luxury six-seat configuration. Now imagine pressing a button in the rear and having the vehicle lower itself automatically for easy loading. With the optional adaptive air suspension, available on the 4.2 Premium, it's a reality. A power tailgate opening for the rear is standard on the 3.6 Premium and 4.2 Premium. When it comes to satisfying our customers, we do all the heavy lifting.

Before we made move one with the seats in the Audi Q7, we studied the way you live. What did we learn? In a word, versatility. After all, you live a multi-faceted life. So changing seat configurations has to be easy.





Audi Q7 3.6 Premium with optional equipment shown.

A reputation for interior excellence will take you only so far.
The Audi Q7 will take you the rest of the way.

The command post. Defiantly and decidedly driver-centric.

An ergonomic masterpiece.

Whether you choose a 3.6 model or the 4.2 Premium, your Audi Q7 arrives lavishly equipped. With a fit and finish that are the envy of the industry. Workmanship that remains beyond reproach. In-dash CD changer. The intuitive, widely praised MMI® operating system. Ten cup and beverage holders. Dual-zone climate control. Tire-pressure monitoring, rain/light sensor and more.

The details are up to you. Adaptive cruise control, Audi side assist, adaptive air suspension, Audi advanced parking system with rearview camera, new Audi lane assist? Our goal with select options is to match and then surpass the very best luxury touring sedans in terms of comfort, convenience and safety. With a craftsmanship and style that inevitably send others back to their drawing boards. We invite you to analyze your needs and then decide which packages, stand-alone options and accessories best suit you and your lifestyle.



Attention to detail. It can mean hand stitching a seat. Raising the center console for a sports car feel. Or making sure every touch pleases and informs.

Audi Q7 3.6 Premium with optional equipment shown.



We believe in empowering the right hand as well as the right foot.
 A holistic approach to driving in the 21st century.



What will your MMI screen display? The latest downloads on your iPod® via the new Audi Music Interface system* Tire pressure. A map of your hometown. A list of SIRIUS® channels. Suspension mode. Depending on the model and the options you select, the possibilities are, in fact, infinite. And as individual as you are. MMI has been tagged as one of the most intuitive, least intrusive operating systems on the market. Information on the vivid, centrally located screen is supplemented by the Driver Information Display. Bluetooth® is standard on both the 3.6 Premium and the 4.2 Premium.

For 2008, leather seating is now standard on every Audi Q7. We also offer Convenience, Technology, S line and Cold weather packages. Heated front seats are standard on both the 3.6 Premium and 4.2 Premium models. The Cold weather package heats the second-row outboard seats as well as the steering wheel. The Specifications section in the back of this brochure will help you to configure just the car you want.



Acoustic Lens Technology is an integral part of the new Bang & Olufsen® Advanced Sound System option. When not in use, the two front tweeters disappear from view. For those to whom exquisite sound really matters, it's a must.

In addition to distinct option packages, we also offer a number of individual choices. From a three-pane Panorama sunroof to Premium Cricket leather seating to four-zone climate control to an adaptive air suspension and beyond.

New for 2008: The optional new Bang & Olufsen Advanced Sound System** from the legendary Danish audiophiles, an Extended Leather package, even 20" chrome wheels. Our goal: An Audi Q7 that's yours and yours alone.

Rest assured though, every 2008 Audi Q7 bristles with well thought out touches: From an optional power tailgate to privacy glass to eight-way power front seats with lumbar support and more, the beauty of this car on the outside is surpassed only by what's inside.

When it's time for a vacation getaway, an optional towing package can transport up to 6,600 pounds.

*Not available on 3.6 base model.
 **Delayed introduction, limited availability.



S line package: Because what you drive is a reflection of who you are.

It starts with the requisite privacy glass you'll now find on every 2008 Audi Q7. And it just doesn't stop. The S line package makes a statement inside and out. First we modify the front grille and install exclusive front and rear bumpers. Compelling S line badging, monochromatic paint and your choice of distinctive 20" or 21" wheels complete the exterior part of the S line package equation.

Now look at the interior: Brushed aluminum trim, black velour carpeting, S line badging on the front sills and an S line three-spoke multi-function steering wheel with paddle shifters. No boxy, run-of-the-mill SUV for you. Far from it.

And under the hood? Your choice of either the 280 hp 3.6 liter V6 or the 350 hp V8. In other words, a powerful statement.



In addition to the 20" wheels with five spokes, we offer 21" wheels with seven double-spokes. See your dealer for details.

The S line-badged, three-spoke multi-function steering wheel with paddle shifters never lets you forget the sports heritage of the car you're driving.

Audi Q7 4.2 Premium with S line package and other optional equipment shown.

There remains an irrefutable logic to four driven wheels.

And we've proved it for more than 25 years.

In 1980, Audi introduced the world to a revolution in luxury production cars: Permanent all-wheel drive. We called it quattro. After thoroughly dominating races and rallies around the globe, the world knew for sure that we were onto something big. In the interim, we never stopped improving our breakthrough. The quattro system in the Audi Q7 features asymmetric/dynamic torque distribution. With a 40/60 torque split under normal conditions, a decidedly sporting bias. Now add the ability to shift up to 85% of the engine's power to the rear and it's easy to understand why there's quattro. And not quite. Not quite as seamless. And not nearly as tested by both time and track.

Standard on every Audi Q7, quattro blends pure mechanical brilliance with an array of electronic assists that establishes a connection to the road for a feeling of supreme confidence under a variety of conditions. The Electronic Stability Program (ESP®) incorporates rollover mitigation, off-road mode as well as Hill Descent Assist.

Every Audi Q7 also features a smooth six-speed Tiptronic® transmission. Benefits: Uncanny responsiveness at low speeds as well as flexibility at cruising speeds.



Capturing the prestigious Pikes Peak Hill Climb three years in a row did wonders to cement quattro's reputation.

With all due respect to its pampered passengers,
this car has one seat that's truly extraordinary.

A feeling of confidence and control starts before the engine springs to life or a single revolution of its stunning wheels. It begins the moment you get behind its four-spoke steering wheel and settle into the sumptuous and supportive driver's seat. Once underway, you feel the benefits of Servotronic® power steering – ease around town with progressive resistance as speed increases.

With each depression of your right foot, the benefits of FSI® Direct Injection become abundantly clear. Both the 280 hp 3.6 liter V6 and the 350 hp 4.2 liter V8 feature this technology that made its debut at the 2001 24 Hours of Le Mans. Depositing a precise mixture of fuel and air directly into each cylinder allows an FSI-equipped engine to run both stronger and longer.



Audi has long believed in taking what we learn in the heat of competition and applying it to your everyday life.



Responsive, responsible engines. With suspension options designed to conquer any road, even no road at all.



The coil-and-spring suspension on the 2008 Audi Q7 offers both effective road feel and impressive ground clearance. But with the optional adaptive air suspension available on 4.2 Premium models, we take it up, and down, another notch. With five distinct modes, including a "LOAD" feature, you're able to precisely tailor the ride to the road as well as to the situation at hand. Unparalleled flexibility. Both suspensions benefit from Audi expertise in weight-saving aluminum to further reduce unsprung weight and to sharpen handling.



By shifting the bias to the rear wheels under normal conditions, the all-new quattro system in this vehicle veers to the sporting side at the drop of a hat. Or worse, a loose rock. Better yet: All the driver has to do is drive. No buttons to push, no adjustments. Just drive. In fact, the Audi Q7 continuously studies the way you drive and learns to shift accordingly. We call it DSP. Short for Dynamic Shift Program. You'll call it amazing.



Our goal is to make sure all of our new technology benefits the driver. And that the driver is always in charge. From the optional tilt-and-telescoping power steering wheel to options such as Audi lane assist and side assist as well as the advanced parking system complete with rearview camera, our aim is to put the driver at ease.

Like an athlete at the top of the game, the Audi Q7 strives to be the best.



Were we at all surprised when the National Highway Traffic and Safety Administration awarded the Audi Q7 the government's highest ratings in frontal and side-impact crash tests? Not a bit. After all, we crashed the car ourselves countless times – virtually and in our state-of-the-art crash hall.



Lane Assist:
New for 2008, Audi lane assist uses a forward-facing camera in the rearview mirror as well as logic software to help to keep your vehicle in its proper lane. Should you begin to waver, a motor mounted in the steering wheel vibrates an alert. Particularly useful on long journeys. Lane assist can be deactivated at the touch of a button.

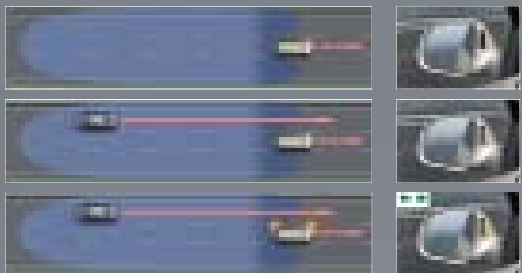

Side Assist:
Radar-controlled side assist uses lights in the side mirrors to alert the driver to obstacles on either side. With a quick flash, you're aware of traffic around you like never before. Those who opt for our advanced parking system option benefit from a camera mounted in the rear for yet another level of protection.

* Government star ratings are part of the National Highway Traffic Safety Administration's (NHTSA's) New Car Assessment Program (www.safercar.gov).

** Airbags are supplemental restraints only and will not deploy under all accident circumstances. Always use safety belts and seat children in the rear, using restraint systems appropriate for their age and size.

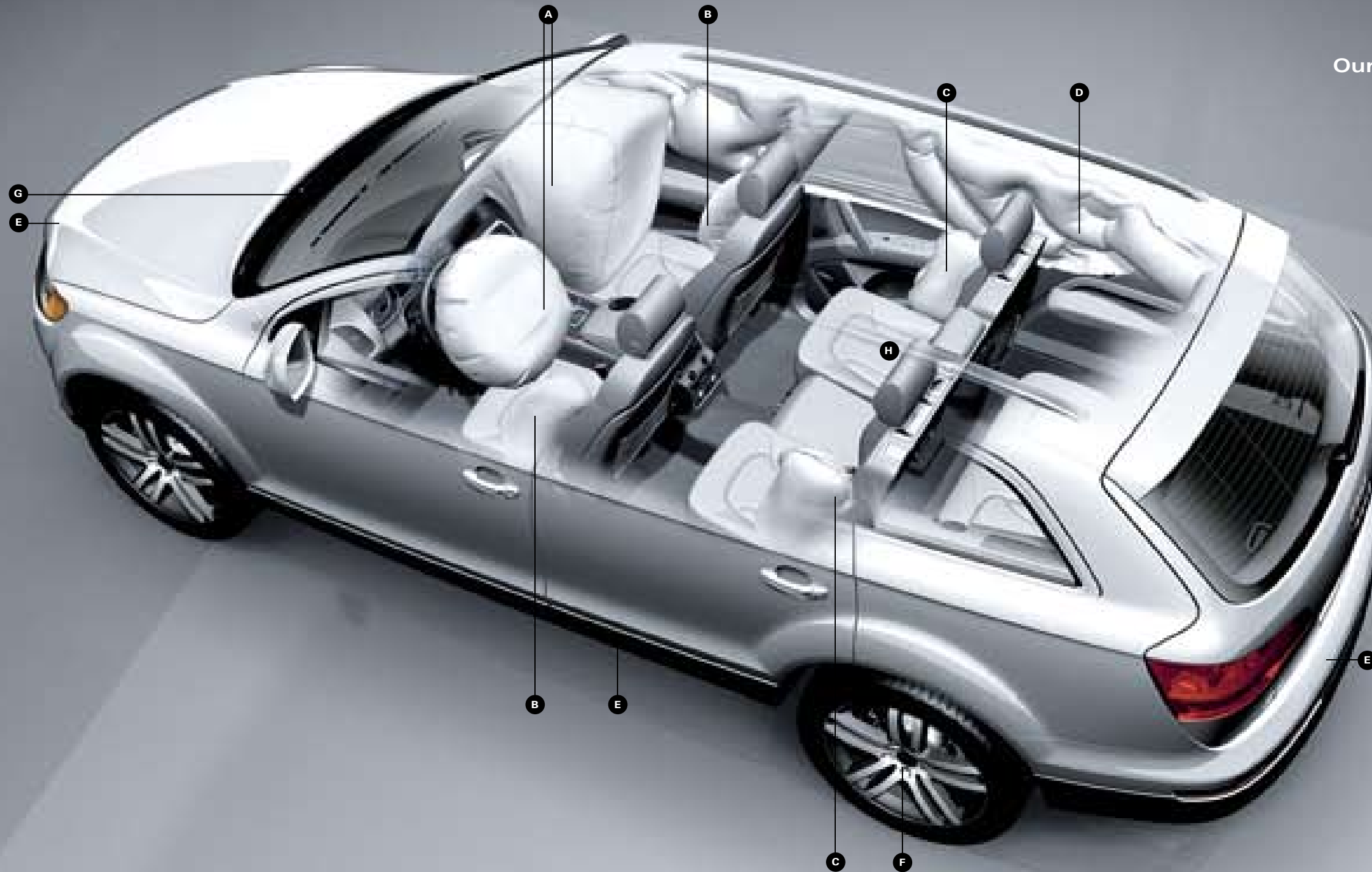

Our definition of safety is all encompassing.

After all, there is no greater luxury.

We're all for an array of airbags and the like, but at Audi safety starts with actively staying on the road and controlling the car under a variety of scenarios. But we didn't stop with the outstanding stability and traction of legendary quattro all-wheel drive. Or a wealth of electronic assists, starting with a next-generation Electronic Stability Program (ESP). Or pre-programmed crumple zones.

From available bi-xenon plus adaptive headlights that automatically illuminate what's around the next corner to standard power exterior mirrors, we focus on the details. And then we rise to the next level. Audi side assist and new Audi lane assist are two components of a Technology package that could have just as easily been called the peace-of-mind package. Standard on both the 4.2 Premium and 3.6 Premium, the advanced parking system, complete with rearview camera, provides yet another layer of confidence.

Our goal, always: Engage the driver. But should the unthinkable become the unavoidable, we deploy next-generation, dual-stage/dual-threshold front and side airbags** as well as comprehensive Sideguard™ side airbags** that cover all three rows. No wonder the NHTSA awarded the Audi Q7 five stars in front and side-impact crash tests.* As well as outstanding marks in rollover resistance.

- A** Next-generation front airbags** for driver and front passenger.
- B** Seat-mounted side airbags** for driver and front passenger.
- C** Second-row seat airbags,** optional.
- D** Comprehensive Sideguard airbags** for all three rows, with rollover sensor.
- E** An array of front, rear, side exterior and interior parking sensors.
- F** ABS anti-lock brakes at all four wheels.
- G** Electronic Stability Program (ESP) with rollover mitigation.
- H** Lower Anchors and Tethers for Children (LATCH) seat attachments.



In all the ways that truly count, we're just like you. We care about those we love. And will never build a car that offers less than our best when it comes to active and passive safety.



When the accent is on accessories, the Audi Q7 shines.

What will you add to your Audi Q7?



The closed ski and luggage box allows you to ride in comfort while your gear and baggage are safely stowed in this aerodynamic box. The interior ski rack can accommodate skis up to 6.5 feet. Installs easily on the base carrier rack.



With their distinctive two-tone, ten double-spoke design, the optional 20" alloy wheels make quite a graphic statement. The outside surface of the wheel has a polished silver sheen while the inner surfaces of the wheel are finished in a contrasting gray.



Rugged all-weather front floor mats are an ideal complement to the distinctive Off-road style package. See your dealer for more details.



Bring along your DVDs and CDs. With a vivid 7" screen and earphone jack, the optional Rear Seat Entertainment package makes long journeys shorter. And since it removes easily, the fun doesn't end when you arrive. See your dealer for details.

Audi Q7 4.2 Premium with optional equipment and dealer-installed accessories shown.

The growing world of Audi: From travel purveyors to makers of luxury and sporting goods, we associate only with the best.



Audi Q7 3.6 Premium with optional equipment shown.

Audi Q7 Specifications

	Power and Performance
Audi Q7 4.2 Premium	<ul style="list-style-type: none"> ▶ 350 hp – DOHC 90-degree 4.2 liter V8 with FSI® Direct Injection, variable intake manifold and continuous camshaft adjustment ▶ Displacement: 4.2 liters ▶ Bore: 3.33 in. ▶ Stroke: 3.65 in. ▶ Compression ratio: 12.5:1 ▶ Horsepower: 350 hp @ 6800 rpm ▶ Torque: 325 lb-ft @ 3500 rpm ▶ 0-60 mph in seconds: 7.0 ▶ Top track speed¹: 130 mph ▶ Fuel economy estimates, city/highway²: 12/17 mpg

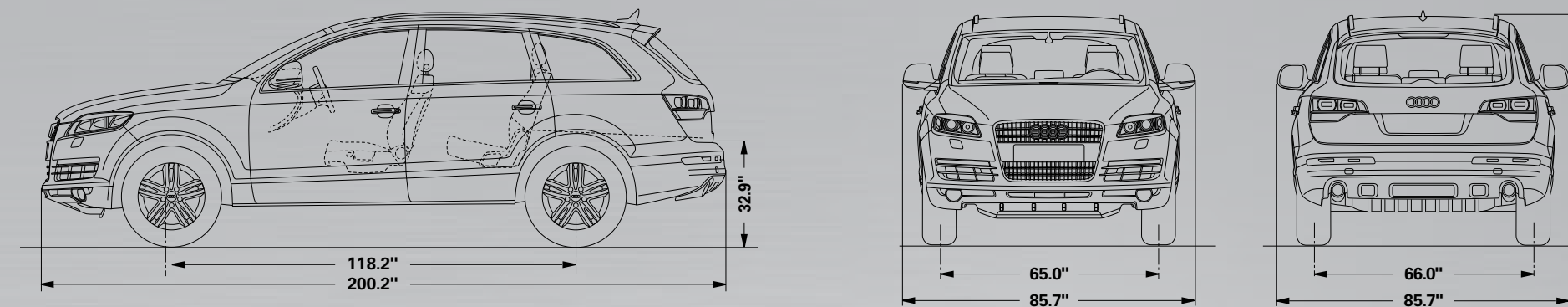

Model Configurations

- ▶ Audi Q7 4.2 350 hp with 6-speed Tiptronic® automatic transmission and quattro® all-wheel drive
- ▶ Audi Q7 3.6 280 hp with 6-speed Tiptronic automatic transmission and quattro all-wheel drive

Audi Q7 3.6	<ul style="list-style-type: none"> ▶ 280 hp – DOHC 3.6 liter V6 with FSI Direct Injection and variable valve timing ▶ Displacement: 3.6 liters ▶ Bore: 3.50 in. ▶ Stroke: 3.80 in. ▶ Compression ratio: 12.0:1 ▶ Horsepower: 280 hp @ 6200 rpm ▶ Torque: 266 lb-ft @ 2750 rpm ▶ 0-60 mph in seconds: 8.2 ▶ Top track speed¹: 130 mph ▶ Fuel economy estimates, city/highway²: 14/18 mpg
--------------------	---

¹Top track speed electronically limited to 130 mph in the U.S.
²Your mileage may vary. See your local Audi dealer for details.

Wheels

Audi Q7 3.6	Audi Q7 3.6 Premium	Audi Q7 4.2 Premium	Wheels
S	S	n/a	(A) 18-inch five double-spoke design cast alloy wheels with 255/55 all-season tires
n/a	O	n/c	(B) 19-inch seven-arm design cast alloy wheels with 265/50 all-season tires
n/a	O	S	(C) 20-inch five double-spoke design bi-color cast alloy wheels with 275/45 all-season tires
n/a	O	O	(D) 20-inch five-spoke cast alloy wheels with 275/45 all-season tires (standard on S line package)
n/a	O	O	(E) 21-inch seven double-spoke cast alloy wheels with 295/35 summer performance tires* (optional on S line package)

S = standard O = optional n/a = not applicable n/c = no-charge option

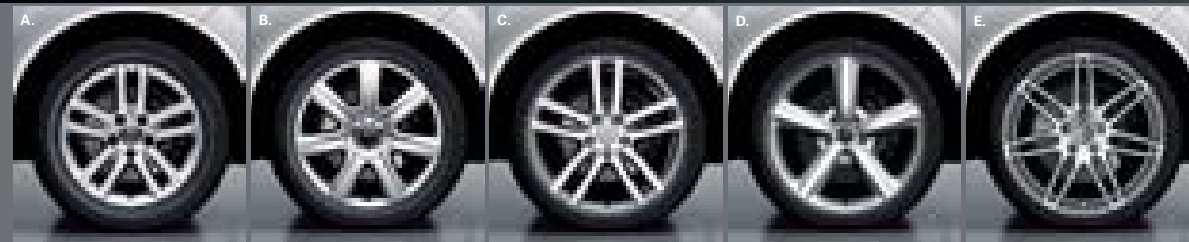

*These tires are designed for optimum performance and handling in warm climates. They are not suitable for cold, snowy or icy weather conditions. If you drive under those circumstances, you should equip your vehicle with all-season or winter tires, which offer better traction under those conditions. We suggest you use the recommended winter or all-season tires specified for your car or its equivalent. These summer performance tires also have a lower aspect ratio that aids performance and handling; however, in order to avoid tire, rim or vehicle damage, it is important that the inflation pressure is regularly checked and maintained at recommended levels. Please also remember in making your selection that, while these tires deliver responsive handling, they may ride less comfortably and make more noise than other choices. Finally, these tires may wear more quickly than other choices. For more information on all of these topics, please consult the owner's manual, your local dealer or call 1-800-FOR-AUDI. ¹Airbags are supplemental restraints only and will not deploy under all accident circumstances. Always use safety belts and seat children only in the rear, using restraint systems appropriate for their size and age. ²Your Audi vehicle is equipped with a phone preparation utilizing Bluetooth interface to enable hands-free functionality (compatible mobile phones sold separately). You will need a Bluetooth-enabled mobile phone in order to utilize this function. Not all Bluetooth-enabled mobile phone models are compatible with Audi's phone preparation. Visit our Web site, audiusa.com, or contact your local Audi dealer for the latest listing of compatible phones. Audi recommends use of the Audi phone cradle (sold separately) with your mobile phone while operating this vehicle.

Audi Q7 3.6	Audi Q7 3.6 Premium	Audi Q7 4.2 Premium	
-------------	---------------------	---------------------	--

Engine/Transmission/Suspension/Body

S	S	S	Front and rear suspension: Double wishbone independent suspension
S	S	S	Servotronic® electromechanical steering with speed-dependent power assistance

Exterior

S	n/a	n/a	Black roof rails and window trim
n/a	S	S	Chrome roof rails and window trim
S	S	n/a	Power outside mirrors with defog feature
n/a	O	S	Power outside automatically dimming and folding mirrors with defog feature
S	S	n/a	Aerodynamic halogen headlights with integrated low- and high-beam tubes
n/a	O	S	Adaptive bi-xenon plus front lighting
S	S	S	Front foglights
S	S	S	Trailer hitch pre-wiring
S	S	S	Privacy glass
n/a	n/a	S	Two-tone body sills and front and rear bumpers

Safety/Security

S	S	S	Tire-pressure monitoring system
S	S	S	Electronic Stability Program (ESP®) with rollover mitigation, off-road mode and Hill Descent Assist
S	S	S	Electronic Differential Lock (EDL)
S	S	S	Anti-slip Regulation (ASR)
S	S	S	Anti-lock brake system with vacuum power assist, Electronic Brake-pressure Distribution (EBD) and electronic Brake Assist
S	S	S	Sideguard™ head protection airbags ¹ for front and rear occupants (Including third row seating with rollover sensor)
S	S	S	Driver and front passenger dual-stage and dual-threshold next-generation airbag ¹ supplemental restraints with occupant sensor
S	S	S	Driver and front passenger seat-mounted chest side airbags ¹
S	S	S	Front 3-point safety belts with automatic pre-tensioning, height-adjustable upper mounts and force limiters
O	S	S	Three rear 3-point safety belts with automatic pre-tensioning (Height adjustable upper mounts for outer passengers)
S	S	S	Lower Anchors and Tethers for Children (LATCH) in rear seats
n/a	S	S	Third row head restraints
S	S	S	Programmable daytime running lights (Dealer programmable on 3.6 models)
S	S	S	Electric child lock with separate controls
S	S	S	Anti-theft vehicle alarm system with immobilizer
S	S	S	Light/rain sensor
n/a	S	S	Advanced Parking System (APS) with rearview camera

Electronics

S	n/a	n/a	MMI® operating system
n/a	S	S	MMI Advanced operating system with color screen and DSP
S	n/a	n/a	Eight-speaker sound system with AM/FM stereo, Radio Data System (RDS) and Graduated Audio Level Adjustment (GALA)
S	S	S	Six-disc CD changer located in instrument panel
n/a	S	n/a	Eleven-speaker sound system with DSP technology

S = standard O = optional n/a = not applicable

Audi Q7 3.6	Audi Q7 3.6 Premium	Audi Q7 4.2 Premium	
-------------	---------------------	---------------------	--

n/a	O	S	Bose® premium 14-speaker sound system with DSP technology
O	S	S	SIRIUS® Satellite Radio
n/a	S	S	Audi Music Interface (AMI)
n/a	S	S	Phone preparation with Bluetooth® interface ¹
n/a	S	S	Driver information system with onboard computer
n/a	S	S	HomeLink® remote transmitter
S	S	S	Electronic cruise control with coast, resume and acceleration features
S	S	S	Electric rear window defogger with automatic timed shut-off feature
S	S	S	Radio frequency remote locking system with selective unlock, remote tailgate opening, panic function, interior lights and alarm system activation – control integrated in folding ignition key
S	S	S	Retained accessory power after key is removed from ignition
S	S	S	Cruise control

Interior

S	n/a	n/a	Aluminum decorative inlays
n/a	S	S	Genuine wood inlays in instrument panel, center console and door panels and shift knob with aluminum air vents
S	n/a	n/a	Front center armrest
n/a	S	S	Comfort center armrest
S	S	n/a	Manually adjustable tilt-and-telescoping steering column
n/a	n/a	S	Power adjustable tilt-and-telescoping steering column
S	S	S	Leather-wrapped four-spoke multi-function steering wheel
S	S	S	Second row 40/20/40 split, flat folding bench seat with armrests and adjustable seatback
O	S	S	Third row seating
S	S	S	Leather seating surfaces
S	S	S	Power driver seat with four-way lumbar adjustment
n/a	O	S	Two-position memory for driver's seat and outside mirrors
S	S	S	Eight-way power passenger seat with four-way lumbar adjustment
n/a	S	S	Heated front seats
S	S	S	Fully automatic dual-zone climate control system with sun sensor and charcoal filter
S	S	S	Power front and rear windows
S	n/a	n/a	Manual tailgate with "Soft Touch" opening
n/a	S	S	Power tailgate
S	S	S	Cargo cover
S	S	S	Storage nets – front seatbacks, front passenger floor and cargo area
S	S	S	Power outlets – two front, two rear, one in cargo area
S	S	S	Interior lighting package
n/a	S	S	Automatically dimming inside mirror with digital compass
n/a	n/a	S	Manual rear and side sunshades

Individual options

O	O	O	Panorama sunroof
O	O	O	Towing package (Increases towing capacity to 6,600 lb.)
O	O	O	Rear side airbags ¹
n/a	O	S	Four-zone climate control system

Audi Q7 3.6	Audi Q7 3.6 Premium	Audi Q7 4.2 Premium	
Individual options			
n/a	O	S	DVD-based Audi Navigation System [†]
n/a	O	O	Premium Cricket leather seating
n/a	n/a	O	Adaptive air suspension
n/a	n/a	O	Adaptive cruise control
Audi a la carte options			
n/a	O	O	Extended Leather package
n/a	O	O	Luxury six-seat configuration
n/a	O	O	Genuine Walnut wood four-spoke multi-function steering wheel
n/a	O	O	Alcantara® headliner
n/a	O	O	Bang & Olufsen® Advanced Sound System*
n/a	O	O	Off-road style package
n/a	O	O	20-inch chrome five double-spoke design cast alloy wheels with 275/45 summer performance tires ^{††}

Audi Q7 3.6	Audi Q7 3.6 Premium	Audi Q7 4.2 Premium	Packages
O	n/a	n/a	Comfort package Third row seating Automatically dimming inside mirror with digital compass Heated front seats SIRIUS Satellite Radio Power tailgate
n/a	O	n/a	Convenience package Power outside automatically dimming and folding mirrors with defog feature Adaptive bi-xenon plus front lighting Two-position memory for driver's seat and outside mirrors Bose premium 14-speaker sound system with DSP technology

Audi Q7 3.6	Audi Q7 3.6 Premium	Audi Q7 4.2 Premium	Packages
n/a	O	O	Technology package (not available with S line package) Advanced key (standard on 4.2 Premium) Audi side assist Audi lane assist Voice control for phone, radio, CD and navigation system DVD-based Audi Navigation System [†] (standard on 4.2 Premium)
n/a	O	O	S line package Leather-wrapped S line three-spoke multi-function steering wheel with shift paddles 20-inch five-spoke cast alloy wheels with 275/45 all-season tires S line grille and front and rear bumpers Aluminum door sills and exterior side panels with S line badge Brushed aluminum interior trim Headlight washers Full body paint
n/a	O	O	S line package with 21-inch wheels 21-inch seven double-spoke cast alloy wheels with 295/35 summer performance tires ^{††}
n/a	O	O	Cold weather package (not available with S line package) Heated rear seats (second row outboard) Heated four-spoke multi-function leather steering wheel

S = standard O = optional n/a = not applicable

[†]The Audi Navigation System depends upon signals from the worldwide Global Positioning Satellite network. The vehicle's electrical system, and existing wireless and satellite technologies, must be available and operating properly for the system to function. The system is designed to provide you with suggested routes in locating addresses, destinations and other points of interest. Changes in street names, construction zones, traffic flow, points of interest or other road system changes are beyond the control of Audi of America, Inc. Complete, detailed mapping of lanes, roads, streets, toll roads, highways, etc., is not possible, therefore you may encounter discrepancies between the mapping and your actual location. Please rely on your individual judgment in determining whether or not to follow a suggested Audi Navigation System route. Periodically the mapping is updated and a new DVD will be required in order to maintain the latest navigation information available to us. These will be available for purchase from time to time at additional cost. Consult your dealer or call 1-800-FOR-AUDI for details. ^{††}These tires are designed for optimum performance and handling in warm climates. They are not suitable for cold, snowy or icy weather conditions. If you drive under those circumstances, you should equip your vehicle with all-season or winter tires, which offer better traction under those conditions. We suggest you use the recommended winter or all-season tires specified for your car or its equivalent. These summer performance tires also have a lower aspect ratio that aids performance and handling; however, in order to avoid tire, rim or vehicle damage, it is important that the inflation pressure is regularly checked and maintained at recommended levels. Please also remember in making your selection that, while these tires deliver responsive handling, they may ride less comfortably and make more noise than other choices. Finally, these tires may wear more quickly than other choices. For more information on all of these topics, please consult the owner's manual, your local dealer or call 1-800-FOR-AUDI. *Delayed introduction, limited availability.



A. An optional three-pane Panorama sunroof lets the outside in for all passengers.

B. The Off-road style package includes distinctive cladding as well as side sills.



B.

C. Four-zone climate control is standard on 4.2 Premium models and a stand-alone option on 3.6 Premium models.



D. With heated front seats now standard on both the 3.6 Premium and 4.2 Premium models, the Cold weather package includes heated rear seats and a heated steering wheel.

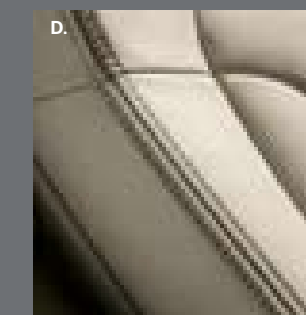

E. New for 2008, the optional Bang & Olufsen Advanced Sound System* with 12 speakers, complete with Acoustic Lens Technology.



F. A DVD-based Navigation System is optional on 3.6 Premium models and standard on 4.2 Premium models.



For more information on these and other select options, see your dealer or visit audiusa.com.

Color Choices

Exterior Colors	Leather Seating Surfaces			Premium Leather Seating			
	Black	Cardamom Beige	—	Black	Cardamom Beige	Limestone Gray	—
Calla White	Black	Cardamom Beige	—	Black	Cardamom Beige	Limestone Gray	—
Ice Silver metallic	Black	—	Limestone Gray	Black	—	Limestone Gray	Espresso Brown
Condor Gray metallic	Black	Cardamom Beige	Limestone Gray	Black	Cardamom Beige	Limestone Gray	—
Lava Gray pearl effect	Black	Cardamom Beige	Limestone Gray	Black	Cardamom Beige	Limestone Gray	Espresso Brown
Phantom Black pearl effect	Black	Cardamom Beige	Limestone Gray	Black	Cardamom Beige	Limestone Gray	Espresso Brown
Cobalt Blue metallic	Black	Cardamom Beige	Limestone Gray	Black	Cardamom Beige	Limestone Gray	—
Bahia Beige metallic	Black	Cardamom Beige	—	Black	Cardamom Beige	—	Espresso Brown
Quartz Gray metallic*	Black	—	Limestone Gray	Black	—	Limestone Gray	Espresso Brown
Garnet Red pearl effect*	Black	Cardamom Beige	Limestone Gray	Black	Cardamom Beige	Limestone Gray	—
Mugello Blue pearl effect†	Black	—	—	Black	—	—	—
Daytona Gray pearl effect†	Black	—	—	Black	—	—	—

*Premium charge applies. †S line only.

Seating	Upper Dashboard	Carpets	Headliner	Trim	
				3.6	3.6 Premium/ 4.2 Premium
Black	Black	Black	Limestone Gray	Aluminum	Medium Brown Walnut wood
Limestone Gray	Limestone Gray	Gray	Limestone Gray	Aluminum	Olive Ash wood
Cardamom Beige	Taupe	Beige	Cardamom Beige	Aluminum	Medium Brown Walnut wood
Espresso Brown	Black	Black	Limestone Gray	—	Brown Tamo wood

Medium Brown Walnut wood
Olive Ash wood
Brown Tamo wood

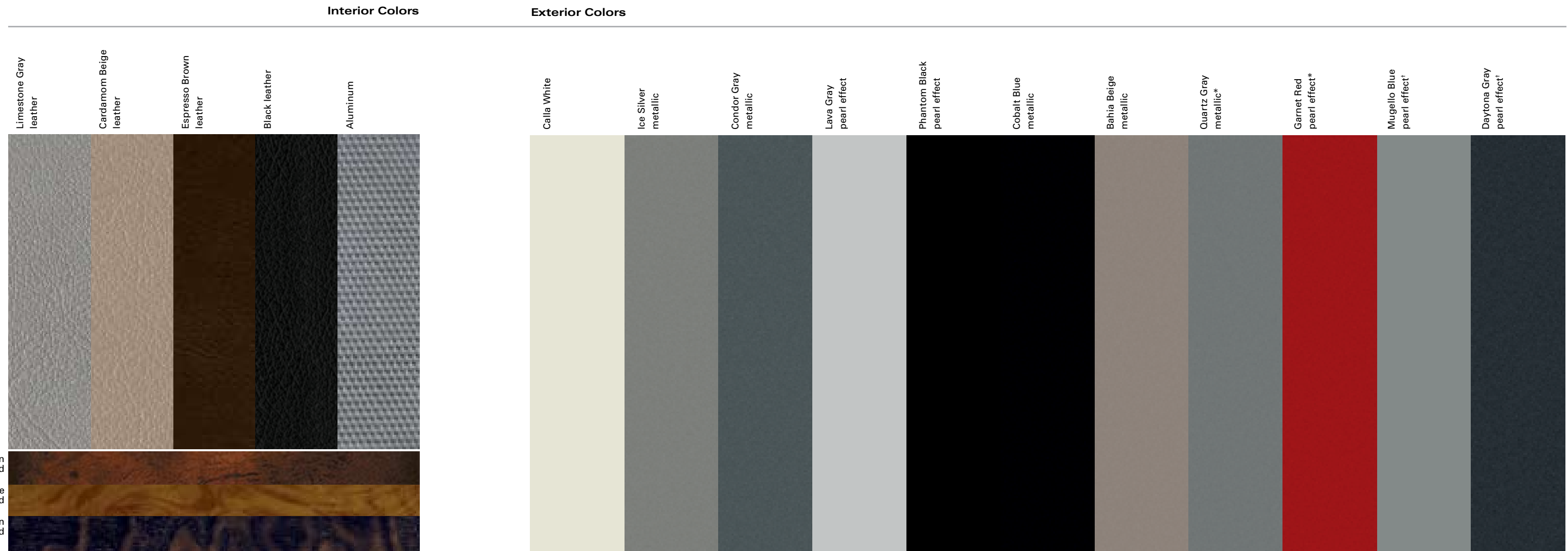

*Premium charge applies. †S line only.



“The only innovations that interest me are the ones that lead to greater strength and quality.” - August Horch, Founder- Horch/Audi

A man of strong convictions, August Horch left a comfortable position when it became clear that the only way to see if his innovations would work was to start his own car company. First Horch. And then Audi. Two of the four companies symbolized by interlocking rings. His belief in advanced technology, responsive performance, inspired design and consummate safety led to quattro, the ASF, FSI, TDI as well as hundreds of checkered flags from Le Mans to Pikes Peak. From the iconic TT to the intuitive MMI operating system to zinc galvanizing to high safety scores across the

board, a zeal to test limits and challenge convention. You can see it in the all-new R8. Feel it in every car with quattro. Sense it in the stunning all-new S5. Hear it every time you close a door. From humble origins in Germany more than 100 years ago to cars sold in more than 100 markets around the globe, it's been quite a journey. The singular vision of one man now shared by millions. And growing by leaps and bounds. All because of a conviction that when it comes to design, performance, technology and safety, there are no shortcuts. **TRUTH IN ENGINEERING.**

audiusa.com

Note: A word about this brochure. Audi of America, Inc. believes the specifications in this brochure to be correct at the time of printing. However, specifications, standard equipment, options and colors are subject to change without notice. Some equipment may be unavailable when your vehicle is built. Please ask your dealer for advice concerning current availability of standard and optional equipment and verify that your vehicle will include the equipment you ordered. Vehicles in this brochure are shown with optional equipment. See your dealer for complete details on the limited warranty, Audi 24-hour Roadside Assistance (Coverage provided by Road America in the U.S. Certain conditions apply, see your dealer for details.) and 12-year limited warranty against corrosion perforation. Tires supplied by various manufacturers. "Audi," "Q7," "quattro," "FSI," "MMI," the four rings and Audi emblems are registered trademarks and "Sideguard" is a trademark of Audi AG. "Servotronic" is a registered trademark of the AM General Corporation. "Tiptronic" is a registered trademark of Dr. Ing. h.c. F. Porsche AG. "Bose" is a registered trademark of the Bose Corporation. "Alcantara" is a registered trademark of Alcantara S.P.A. "ESP" is a registered trademark of DaimlerChrysler AG. "HomeLink" is a registered trademark of Prince Corporation, Holland, Michigan. Prince is a wholly owned subsidiary of Johnson Controls™. "Bang & Olufsen" is a registered trademark of Bang & Olufsen. "SIRIUS" is a registered trademark of SIRIUS Satellite Radio, Inc. "Bluetooth" is a registered trademark of Bluetooth SIG. "iPod" is a registered trademark of Apple Computer, Inc.

A word about updated service information. Audi regularly sends its dealers useful service information about its products. Audi monitors product performance in the field, then prepares bulletins to better service its products and help avoid costly repairs. To order, see your local Audi dealer.

©2007 Audi of America, Inc.

Printed in U.S.A.
C-Q7-08-005US