

1995 FORD

PICKUPS & CHASSIS

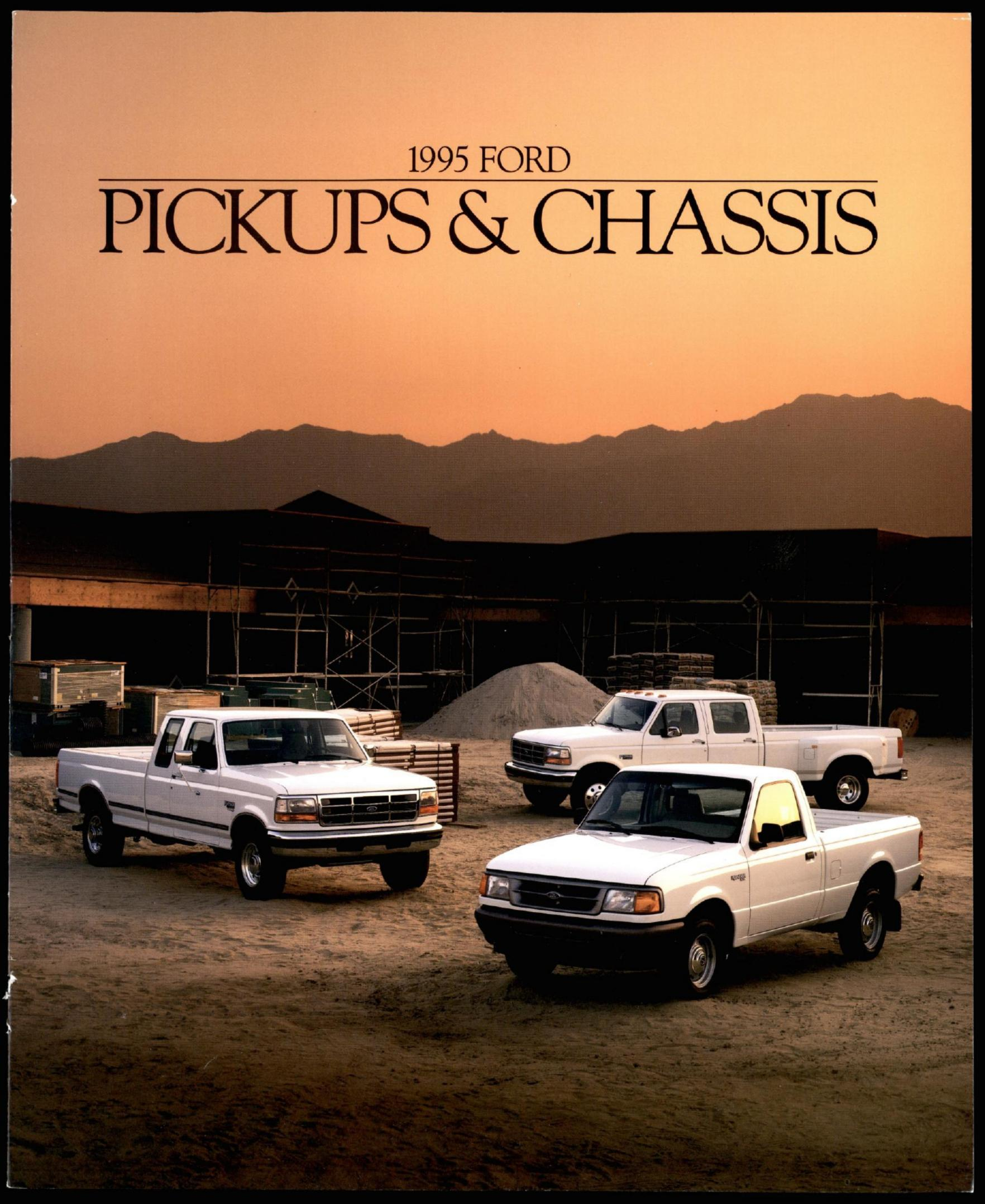

1995 FORD COMMERCIAL PICKUPS AND CHASSIS



No one knows more about trucks than Ford. We've been engineering and building them for over 75 years.

FORD. THE NAME TO LOOK TO FOR TOUGH AND READY WORK TRUCKS!

Our strong reputation for toughness, dependability and service has been earned through long and hard work in every commercial market. So it's not surprising that the F-Series has been the best-selling full-size pickup for 17 straight years; and that the Bronco, Econoline and Ranger are also the best-selling trucks in their classes.*

Ford trucks are *Built Ford Tough!* They're put through exhaustive on- and off-road testing under demanding operating conditions, so that they will

**Ford Trucks.
The Best Never Rest.**

have the attributes of toughness and dependability you need in a truck.

FULL LINE OF RUGGED MODELS, INCLUDING A NEW RANGER PICKUP

In this catalog you'll find product information and specifications on the full-size F-Series pickups and chassis-cabs, the new compact Ranger pickup, the F-Series and Econoline stripped chassis models, and the Bronco utility.

They provide the features people who drive trucks for a living expect in ruggedly built work trucks from Ford:

- Twin-I-Beam (4x2) and Twin-Traction Beam (4x4) independent front suspension systems.
- Computer-controlled anti-lock brakes (4-wheel system standard in Bronco and Ranger 4x4; rear wheel system standard in F-Series, Ranger 4x2, and Econoline stripped chassis).

■ Driver-side air bag to supplement the safety belts—standard in F-Series under 8,500-lbs. GVWR, Bronco, and now also in the new Ranger pickup.

■ A range of multi-port fuel-injected gas engines, from the 2.3-liter I-4 in Ranger on up to the big 7.5-liter V-8 available in F-Series (over 8,500-lbs. GVWR) and Econoline stripped chassis.

POWER STROKE TURBO DIESEL: MOST ADVANCED AND POWERFUL

And there's the optional Power Stroke 7.3-liter V-8 turbo diesel that's available in F-Series models over 8,500-lbs. GVWR.

The Power Stroke turbo diesel is the most advanced and the most powerful diesel ever put in a pickup.

When you're looking for a truck to get your job done, be sure to look to Ford, where The Best Never Rest.

*Based on manufacturers' reported retail deliveries through April, 1994.



FORD F-SERIES PICKUP MODELS

- Regular Cab: 117" WB (6' box) or 133" WB (8' box)
- SuperCab: 139" WB (6' box) or 155" WB (8' box)
- Crew Cab: 168" WB (8' box)

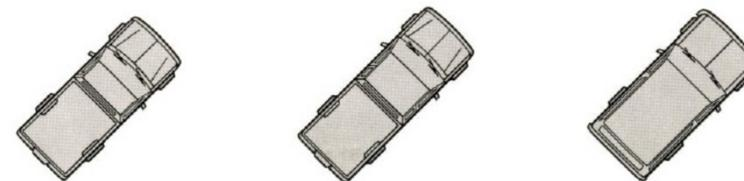

FORD RANGER PICKUP AND BRONCO MODELS

- Regular Cab: 108" WB (6' box) or 114" WB (7' box)
- SuperCab: 125" WB (6' box)
- Bronco: 105" WB

CONTENTS

F-Series Pickup	4-5
F-Series Power	6
F-Series Specifications	7
F-Series Payloads and Equipment	8
Bronco	9
New Ranger Pickup	10-11
F-Series Chassis-Cabs	12-13
Chassis-Cab Specifications	14-15
F-Series and Econoline Stripped Chassis	16-17
Trailer Towing	18-19

FORD F-SERIES

Ford F-Series is engineered to satisfy the demands of commercial driving. Ruggedness and performance. Comfort and safety. F-Series pickups are, and always have been, *Built Ford Tough!*

WIDE RANGE OF POWERPLANTS, GASOLINE AND TURBO DIESEL

F-Series' four gas-powered engines feature multi-port electronic fuel injection for precise fuel metering, excellent throttle response and easy starting.

For high-torque diesel power, there's the best-in-class power and torque of the Power Stroke 7.3-liter turbo diesel shown and described on page 6.

FORD TOUGH FEATURES ENGINEERED FOR PERFORMANCE AND SAFETY

- Two optional electronic automatic overdrive transmissions—the E4OD and the 4R70W—designed for improved efficiency, performance and shift feel over a vacuum- or cable-controlled system.

- Twin-I-Beam (4x2) and Twin-Traction Beam (F-150/F-250HD 4x4) independent front suspensions.

- Rugged monobeam front axle on the F-350 4x4.

- Extensive use of tough 2-sided galvanized steel.

- Ladder-type frame with a special wax coating for corrosion protection.

- Impact-resistant aero-design halogen headlights.

- Nitrogen gas-pressurized shock absorbers.

- A range of payloads from 1,040 lbs. (F-150 Regular Cab Flareside) to 5,105 lbs. (F-350 Regular Cab DRW).

- Power brakes with computer-controlled rear anti-lock system.

- Side door intrusion beams.

- Driver-side air bag to supplement the safety belts (in F-Series models under 8,500-lbs. GVWR).

THE F-SERIES INTERIOR: DESIGNED FOR COMFORT AND CONVENIENCE

- The optional convertible console seat has individually adjustable driver and right passenger seats; the center

position seat back can be lowered to become a full center armrest with cupholders and storage compartment.

- Gauges are easy to see and read; controls are easy to reach.

- Transmission control switch (with optional E4OD or 4R70W) prevents upshifting to 4th gear.

- A removable mini-console with cupholder(s) is part of the optional Interior Enhancement/Light Group with Regular Cab.

- Manual mirrors are standard; electric remote mirrors are optional on single-rear-wheel models.

- Power Point auxiliary outlet can be used for plugging in accessories like an electric shaver or coffee pot.

THREE CAB STYLES, 4x2 OR 4x4, STYLESIDE OR FLARESIDE

F-Series is available in three cab styles: Regular, SuperCab and Crew Cab. And two pickup box styles: the Styleside and the F-150 Flareside.

In a SuperCab without a rear bench seat, you have 38.4 cu. ft. of extra space; 29.4 cu. ft. in rear bench seat-equipped models with rear seat folded down. And there's the Crew Cab with four doors and ample room for six adults.

If you need extra traction, you have F-150, F-250HD and F-350 4x4s. Plus three 4x4 systems: standard auto-locking front hubs; optional manual-locking hubs; plus the Touch Drive electric shift option available with F-150.

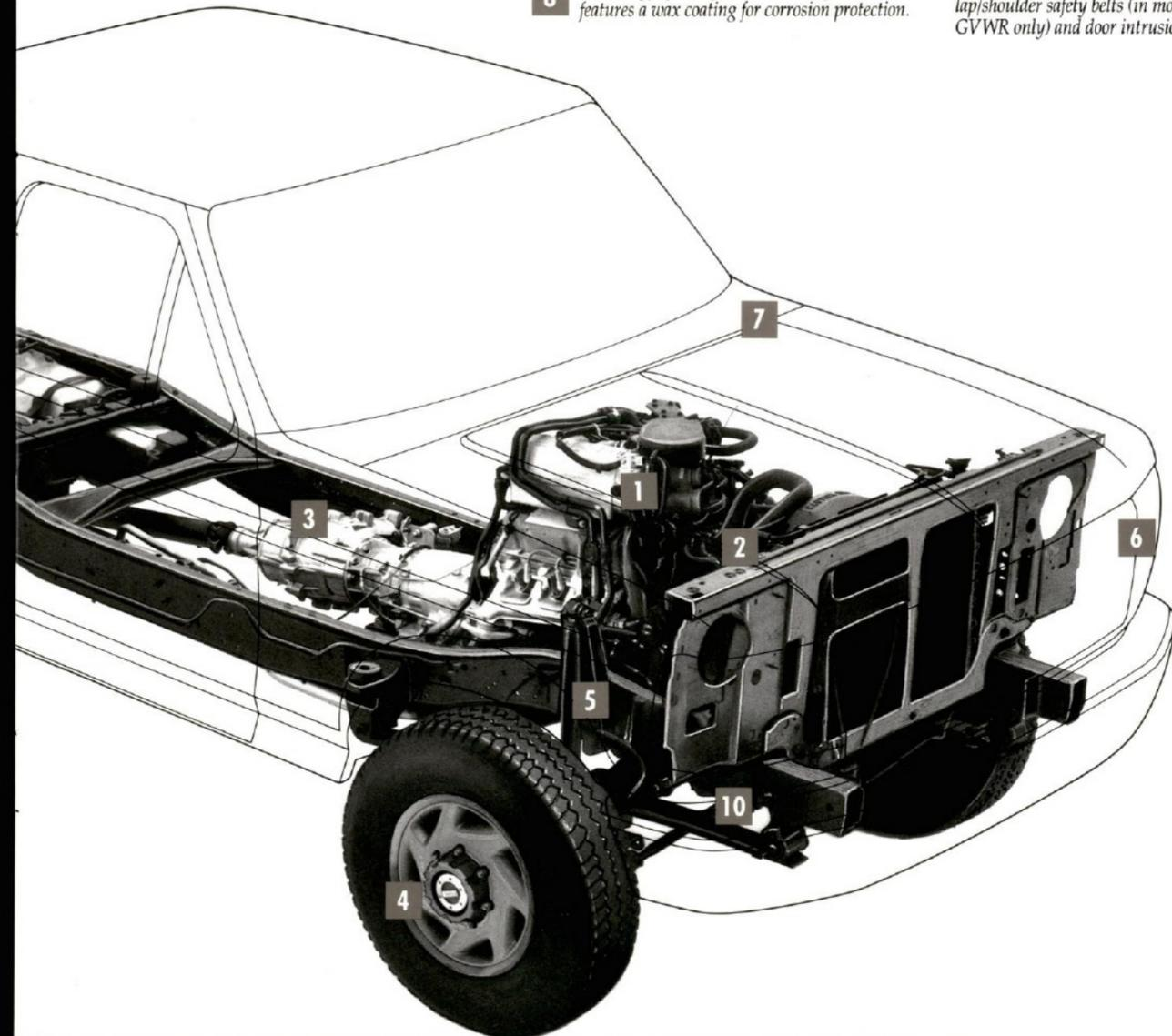
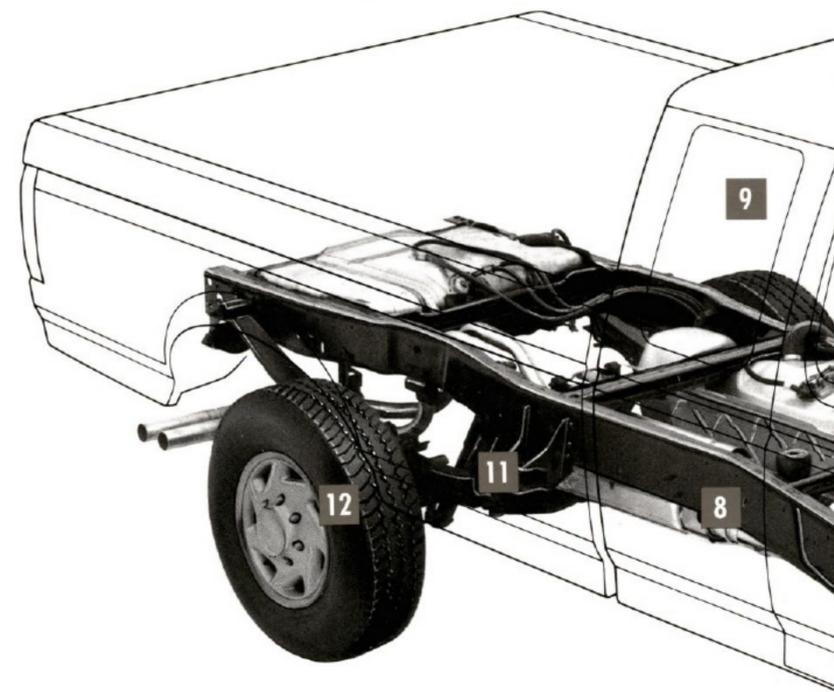

1 All gas engines feature EEC-IV computer-controlled, "multi-port" electronic fuel injection. EEC-IV gathers information on a broad range of operating conditions affecting engine performance and then controls fuel-air mixture and spark timing to optimize performance and efficiency. In effect, EEC-IV fine tunes the engine to the requirements of the moment.

2 Single serpentine accessory belt drive on 4.9L, 5.0L, 5.8L gas and 7.3L turbo diesel engines has a self-tensioning idler pulley (adjustment is not required) and provides easy access to front-mounted components.

3 Two optional electronic 4-speed automatic overdrive transmissions (E4OD and 4R70W) are designed to improve shift feel and performance over a vacuum- or cable-controlled system. The driver-activated overdrive control switch, conveniently located on the shift lever, is particularly useful in obtaining 3rd gear engine braking on downgrades.

4 Automatic locking front hubs are standard on all F-Series 4x4 pickups, with manual-locking hubs optional (shown). The Touch Drive electric shift system is available on F-150 4x4s. With the hubs engaged, all three systems allow you to shift "on the fly" from 2WD to 4WD High and back at normal road speeds.

5 Standard nitrogen gas-pressurized front and rear shock absorbers are designed to help maintain consistent hydraulic fluid pressure for a smooth and controlled ride.

6 Aero-designed headlights have impact-resistant lenses, plus halogen bulbs that can be easily replaced from under the hood without tools.

7 Hood, fenders, dash panel, doors, front floor pan, pickup box and tailgate are two-sided galvanized steel. Roof sheet metal is also galvanized (one-sided).

8 Ladder-type frame provides a solid foundation; features a wax coating for corrosion protection.

9 The SuperCab provides up to 38.4 cu. ft. of additional cargo space in models without a rear bench seat. 3-point rear outboard lap/shoulder belts are included in models equipped with a rear bench seat.

10 Twin-I-Beam (4x2) and Twin-Traction Beam (F-150 and F-250HD 4x4) independent front suspensions feature an axle arm and coil spring (leaf spring in F-250HD 4x4 shown) for each wheel, allowing each wheel to react independently to bumps and road shock for control and a smooth ride.

11 2-stage, multi-leaf rear springs adjust to optimize ride comfort and load carrying capability. Auxiliary springs are standard on F-350 models.

12 Power front disc/rear drum brakes are standard. The rear anti-lock system helps you make more controlled stops under most operating conditions. Also among the F-Series' many safety features are a driver-side air bag designed to supplement the lap/shoulder safety belts (in models under 8,500-lbs. GVWR only) and door intrusion beams.

FORD F-SERIES POWER

Power! It's one of the F-Series' strongest assets—and a main reason the F-Series has been America's best-selling full-size pickup for 17 straight years.*

THE MOST POWERFUL DIESEL EVER IN A PICKUP

The 7.3-liter Power Stroke turbo diesel has more horsepower and torque than any other diesel in a pickup.

It's superbly engineered for excellent fuel economy and durability as well.

The 7.3-liter Power Stroke is the only diesel having high-speed direct injection for smooth driveability plus unit injectors for durability and performance.

Full authority Ford EEC-V electronic engine controls

contribute to excellent throttle response at any temperature, at any load, at any altitude; and also to outstanding cold weather performance.

What's more, the 7.3-liter Power Stroke can be teamed with either a manual or an automatic transmission.

MULTI-PORT FUEL-INJECTED GAS-POWERED ENGINES

Different applications have different power and economy requirements, so F-Series offers a range of gas engines. They have multi-port fuel injection for precise fuel metering, excellent throttle response and easy start-ups—even when it's very cold.

*Based on model year manufacturers' reported retail deliveries by division through April, 1994.

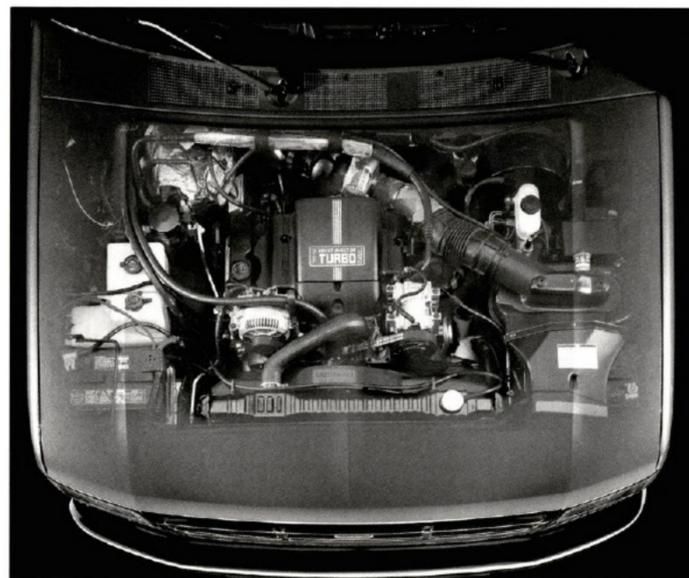

Engines	Regular Cab				SuperCab			Crew Cab	
	F-150	F-250	F-250 HD	F-350 DRW	F-150	F-250 HD	F-350 DRW	F-350 SRW	F-350 DRW
	4.9L EFI I-6	S	S	S	-	S	O	-	-
5.0L EFI V-8	O	O	-	-	O	-	-	-	-
5.8L EFI V-8	O	O	O	S	O	S	-	S	S
7.5L EFI V-8	-	-	O	O	-	O	S	O	O
7.3L Turbo Diesel	-	-	O	O	-	O	O	O	O
Transmissions									
5-spd. manual overdrive	S	S	-	-	S	-	-	-	-
5-spd. manual overdrive HD	-	-	S	S	-	S	S	S	S
3-spd. auto.	-	-	O	O	-	O	-	O	O
Electronic 4-spd. auto overdrive (4R70W)	O	-	-	-	O	-	-	-	-
Electronic 4-spd. auto overdrive (E4OD)	O	O	O	O	O	O	O	O	O

HD = Heavy Duty. SRW = Single Rear Wheels. DRW = Dual Rear Wheels.

Engines	Regular Cab			SuperCab		Crew Cab
	F-150	F-250 HD	F-350 SRW	F-150	F-250 HD	F-350 SRW
	4.9L EFI I-6	S	-	-	S	-
5.0L EFI V-8	O	-	-	O	-	-
5.8L EFI V-8	O	S	S	O	S	S
7.5L EFI V-8	-	O	O	-	O	O
7.3L Turbo Diesel	-	O	O	-	O	O
Transmissions						
5-spd. manual overdrive	S	-	-	S	-	-
5-spd. manual overdrive HD	-	S	S	-	S	S
3-spd. auto.	-	O	O	-	O	O
Electronic 4-spd. auto overdrive (4R70W)	O	-	-	O	-	-
Electronic 4-spd. auto overdrive (E4OD)	O	O	O	O	O	O

HD = Heavy Duty. SRW = Single Rear Wheels. DRW = Dual Rear Wheels.

You've never really driven a turbo diesel until you experience the Power Stroke 7.3-liter direct-injection turbo diesel in an F-Series. It's the most powerful diesel engine ever put in a pickup. And it can be teamed with either a manual or an automatic transmission.

ENGINE SPECIFICATIONS

	Bore x Stroke	Compression Ratio	Horsepower (SAE net)	Torque, lbs./ft. (SAE net)
4.9-liter Multi-Port EFI I-6 (1)	4.00 x 3.98	8.8	145 @ 3,400 rpm	265 @ 2,000 rpm
4.9-liter Multi-Port EFI I-6 (2)	4.00 x 3.98	8.8	150 @ 3,400 rpm	260 @ 2,000 rpm
5.0-liter Multi-Port EFI V-8 (3)	4.00 x 3.00	9.0	205 @ 4,000 rpm	275 @ 3,000 rpm
5.0-liter Multi-Port EFI V-8 (4)	4.00 x 3.00	9.0	195 @ 4,000 rpm	270 @ 3,000 rpm
5.8-liter Multi-Port EFI V-8 (5)	4.00 x 3.50	8.8	210 @ 3,600 rpm	325 @ 2,800 rpm
5.8-liter Multi-Port EFI V-8 (6)	4.00 x 3.50	8.8	205 @ 3,600 rpm	330 @ 2,600 rpm
7.5-liter Multi-Port EFI V-8 (7)	4.36 x 3.85	8.5	245 @ 4,000 rpm	395 @ 2,400 rpm (8)
7.3-liter V-8 Power Stroke Turbo Diesel (7)	4.11 x 4.18	17.5	210 @ 3,000 rpm	425 @ 2,000 rpm

(1) 5-speed manual OD with 2.73 or 3.08 axle ratio, or models below 8,500-lbs. GVWR with electronic 4-speed automatic OD transmission. (2) All applications except those in previous footnote. (3) With manual transmission. (4) With electronic 4-speed automatic OD transmission. (5) 49 States and California over 8,500-lbs. GVWR. (6) California below 8,500-lbs. GVWR. (7) Models over 8,500-lbs. GVWR only. (8) 400 @ 2,200 rpm with electronic 4-speed automatic OD transmission.

FORD F-SERIES SPECIFICATIONS

F-SERIES 4x2

GVWR (max. lbs.)	F-150	6,250: Regular Cab; 6,250: SuperCab
	F-250	6,600: Regular Cab
	F-250HD	8,600: Regular Cab; 8,800: SuperCab
	F-350	10,000: Regular Cab DRW; 10,000: SuperCab DRW 9,200: Crew Cab SRW; 10,000: Crew Cab DRW
Front axle (max. lbs.)	F-150	3,400: Regular Cab; 3,400: SuperCab
	F-250	3,900: Regular Cab
	F-250HD	4,200: Regular Cab; 4,200: SuperCab
	F-350	4,200: Regular Cab DRW; 4,200: SuperCab DRW 4,200: Crew Cab SRW; 4,200: Crew Cab DRW
Rear axle (max. lbs.)	F-150	3,800: Regular Cab; 3,800: SuperCab
	F-250	5,300: Regular Cab
	F-250HD	6,250: Regular Cab; 6,250: SuperCab
	F-350	7,400: Regular Cab DRW; 7,400: SuperCab DRW 6,250: Crew Cab SRW; 7,400: Crew Cab DRW
Springs, front	Coil	
	2-stage leaf, variable rate (plus auxiliary springs on F-350) Opt. auxiliary rear springs for many models. See your Ford Dealer.	
Springs, rear	Coil	
	2-stage leaf, variable rate (plus auxiliary springs on F-350) Opt. auxiliary rear springs for many models. See your Ford Dealer.	
Shock absorbers	Gas-pressurized	
Battery	Std. 72 amp-hr. Opt. 84 amp-hr. Dual 84 amp-hr. std. with 7.3L turbo diesel	
Alternator	95 amps with gas engines; 130 amps with 7.3L turbo diesel	
Fuel capacity (gals.)	Std. 34.7: SWB F-150; 37.2: LWB F-150/F-250/F-250HD/F-350 Opt. 18.2: F-150/F-250/F-250HD Regular Cab	
Steering	Power	
Brakes	Power front disc; power rear drum with anti-lock system	
Wheels, type/rim size	5-hole/6": F-150 8-hole 7K: F-250/F-250HD/F-350 SRW; F-350 DRW 6K	
Tires, tubeless	P215/75R15SL: F-150 Regular Cab P235/75R15XL: F-150 SuperCab LT215/85R16D: F-250 Regular Cab LT235/85R16E: F-250HD/F-350 SRW LT215/85R16D: F-350 DRW Opt. tires are available to match payload package requirements. See your Ford Dealer.	
HD = Heavy Duty. SRW = Single Rear Wheels. DRW = Dual Rear Wheels.		

F-SERIES 4x4

GVWR (max. lbs.)	F-150	6,250: Regular Cab; 6,250: SuperCab
	F-250HD	8,600: Regular Cab; 8,800: SuperCab
	F-350	9,000: Regular Cab SRW 9,200: Crew Cab SRW
Front axle (max. lbs.)	F-150	3,800: Regular Cab; 3,800: SuperCab
	F-250HD	4,600: Regular Cab; 4,600: SuperCab
	F-350	5,000: Regular Cab SRW 5,000: Crew Cab SRW
Rear axle (max. lbs.)	F-150	3,800: Regular Cab; 3,800: SuperCab
	F-250HD	6,250: Regular Cab; 6,250: SuperCab
	F-350	6,250: Regular Cab SRW 6,250: Crew Cab SRW
Springs, front	Coil: F-150. Constant rate tapered leaf: F-250HD/F-350	
	2-stage leaf, variable rate (plus auxiliary springs on F-350) Opt. auxiliary rear springs for many models. See your Ford Dealer.	
Springs, rear	Coil	
	2-stage leaf, variable rate (plus auxiliary springs on F-350) Opt. auxiliary rear springs for many models. See your Ford Dealer.	
Shock absorbers	Gas-pressurized	
Front hubs	Std. auto locking: F-150/F-250HD/F-350 Opt. manual locking: F-150/F-250HD/F-350 Opt. auto locking with Touch Drive: F-150	
Battery	Std. 72 amp-hr. Opt. 84 amp-hr. Dual 84 amp-hr. std. with 7.3L turbo diesel	
Alternator	95 amps with gas engines; 130 amps with 7.3L turbo diesel	
Fuel capacity (gals.)	Std. 18.2: SWB F-150 Regular Cab Std. 34.7: SWB F-150 SuperCab; 37.2: LWB F-150/F-250HD/F-350 Opt. 18.2: LWB F-150/F-250HD/F-350 Regular Cab	
Steering	Power	
Brakes	Power front disc; power rear drum with anti-lock system	
Wheels, type/rim size	5-hole/6": F-150 8-hole 7K: F-250HD/F-350 SRW	
Tires, tubeless	P235/75R15XL: F-150 LT235/85R16E: F-250HD/F-350 Opt. tires are available to match payload package requirements. See your Ford Dealer.	
HD = Heavy Duty. SRW = Single Rear Wheels.		

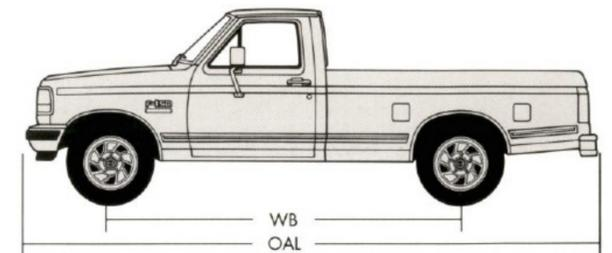

DIMENSIONS

Cab	Series	WB (in.)	OAL (in.)	BL (ft.)	BW (in.)	LH (in.) 4x2/4x4	AC (in.) 4x2/4x4	Cargo (cu ft.)*
Regular	F-150 Styleside	117	197.1	6 1/2	70	30.2/33.5	6.5/7.1	62.9
	F-150 Flareside	117	197.1	6 1/2	49	30.2/33.5	6.5/7.1	44.2
	F-150	133	213.3	8	70	30.2/33.5	6.5/7.1	75.6
	F-250	133	213.3	8	70	32.5/-	7.7/-	75.6
	F-250 HD	133	213.3	8	70	32.2/35.1	8.3/8.3	75.6
	F-350	133	213.3	8	70	-/34.6	-/8.3	75.6
Super	F-350 DRW	133	213.3	8	70	32.5/-	7.7/-	75.6
	F-150 Styleside	139	219.1	6 1/2	70	30.7/33.4	7.1/7.1	62.9
	F-150 Flareside	139	219.1	6 1/2	49	30.7/33.4	7.1/7.1	44.2
	F-150	155	235.3	8	70	30.7/33.4	7.1/7.1	75.6
	F-250 HD	155	235.3	8	70	33.0/35.0	8.3/8.3	75.6
	F-350 DRW	155	235.3	8	70	32.4/-	7.7/-	75.6
Crew	F-350	168	248.8	8	70	34.1/35.6	8.3/8.3	75.6
	F-350 DRW	168	248.8	8	70	32.9/-	7.7/-	75.6

WB = Wheelbase. BL = Inside Box Length (nominal). BW = Inside Box Width (maximum). OAL = Overall Length (without rear bumper). LH = Load Height (estimated empty). AC = Axle Clearance. *Pickup box cargo volume without allowance for wheelhouses.

FORD F-SERIES PAYLOADS & EQUIPMENT

4x2 PAYLOAD PACKAGE SELECTOR

Regular Cab Styleside	Payload Package	Payload* (lbs.)	GVWR (lbs.)	Tires (Min.)
F-150 (6' pickup box)	#1	1,325	5,250	P215/75R15SL
F-150 (6' pickup box)	#2	2,150	6,100	P235/75R15XL
F-150 (8' pickup box)	#1	1,410	5,450	P215/75R15SL
F-150 (8' pickup box)	#2	2,205	6,250	P235/75R15XL
F-250 (8' pickup box)	#1	2,280	6,600	LT215/85R16D
F-250HD (8' pickup box)	#1	4,045	8,600	LT235/85R16E
F-350 DRV (8' pickup box)	#1	5,105	10,000	LT215/85R16D
Regular Cab Flareside				
F-150 (6' pickup box)	#1	1,040	5,000	P235/75R15XL
F-150 (6' pickup box)	#2	1,490	5,450	P235/75R15XL
F-150 (6' pickup box)	#3	2,100	6,100	P235/75R15XL
SuperCab				
F-150 (6' pickup box)	#1	1,850	6,050	P235/75R15XL
F-150 (8' pickup box)	#1	1,940	6,250	P235/75R15XL
F-250HD (8' pickup box)	#1	4,025	8,800	LT235/85R16E
F-350 DRV (8' pickup box)	#1	4,655	10,000	LT215/85R16D
SuperCab Flareside				
F-150 (6' pickup box)	#1	1,780	6,050	P235/75R15XL
Crew Cab				
F-350 (8' pickup box)	#1	3,970	9,200	LT235/85R16E
F-350 DRV (8' pickup box)	#1	4,570	10,000	LT215/85R16D

*Maximum allowable weight of people, cargo and body equipment, and is reduced by the weight of optional equipment. Most Regular Cab payloads can be increased by ordering the single fuel tank option. See your dealer for more information.

HEAVY-DUTY SUSPENSION EQUIPMENT (UNDER 8,500-LBS. GVWR)

	F-150	F-250
HD Front Suspension Package*	<input type="checkbox"/> 3,800-lbs. springs/GAWR <input type="checkbox"/> Heavy-duty frame <input type="checkbox"/> Min. 3.55 rear axle ratio (must be ordered)	
HD Rear Suspension Package	<input type="checkbox"/> 400-lbs. capacity auxiliary springs**	<input type="checkbox"/> 710-lbs. capacity auxiliary springs**

*Heavy-Duty Front Suspension Package is recommended on vehicles which will permanently utilize aftermarket equipment such as snow plows, heavy-duty winches and others that load the front axle to the specified Gross Axle Weight Rating (GAWR). **Nominal rating.

4x4 PAYLOAD PACKAGE SELECTOR

Regular Cab	Payload Package	Payload* (lbs.)	GVWR (lbs.)	Tires (Min.)
F-150 (6' pickup box)	#1	2,035	6,100	P235/75R15XL
F-150 (8' pickup box)	#1	1,925	6,250	P235/75R15XL
F-250HD (8' pickup box)	#1	3,630	8,600	LT235/85R16E
F-350 (8' pickup box)	#1	3,940	9,000	LT235/85R16E
Regular Cab Flareside				
F-150 (6' pickup box)	#1	1,985	6,100	P235/75R15XL
SuperCab				
F-150 (6' pickup box)	#1	1,815	6,250	P235/75R15XL
F-150 (8' pickup box)	#1	1,690	6,250	P235/75R15XL
F-250HD (8' pickup box)	#1	3,560	8,800	LT235/85R16E
SuperCab Flareside				
F-150	#1	1,740	6,250	P235/75R15XL
Crew Cab				
F-350 (8' pickup box)	#1	3,565	9,200	LT235/85R16E

*Maximum allowable weight of people, cargo and body equipment, and is reduced by the weight of optional equipment. Most Regular Cab payloads can be increased by ordering the single fuel tank option. See your dealer for more information.

HEAVY-DUTY SUSPENSION EQUIPMENT (OVER 8,500-LBS. GVWR)

	F-250HD	F-350 4x4
HD Front Suspension Package*	<input type="checkbox"/> 4,600-lbs. springs/GAWR <input type="checkbox"/> 4.10 rear axle ratio (must be ordered)	<input type="checkbox"/> 4,800-lbs. GAWR <input type="checkbox"/> 5,000-lbs. springs
HD Rear Suspension Package	<input type="checkbox"/> 710-lbs. capacity auxiliary springs**	

*Heavy-Duty Front Suspension Package is recommended on vehicles which will permanently utilize aftermarket equipment such as snow plows, heavy-duty winches and others that load the front axle to the specified Gross Axle Weight Rating (GAWR). **Nominal rating.

FORD BRONCO



Year after year, for fifteen straight, the Ford Bronco has been the best-selling full-size utility vehicle.*

This is success earned on solid performance and value. Standard 5.0-liter V-8 power and a 4-wheel anti-lock brake system are on Bronco's list of superb engineering features.

BRONCO FEATURES

- A roomy interior with comfortable seating, ergonomically designed and positioned instruments and controls.
- Standard vinyl bucket seats (XL) or cloth captain's chairs (XLT and Eddie Bauer). Available 3-passenger front bench seat (XL and XLT).
- Driver-activated transmission control switch to prevent shifting into overdrive when braking on downgrades.
- Driver-side air bag to supplement the safety belts.
- Rear seat outboard lap/shoulder safety belts.

- Power Point auxiliary electrical outlet located on the instrument panel for plugging in things like coffee pots during break time.

- Special wax coating on the frame for corrosion protection.
- Twin-Traction Beam independent front suspension system.
- 79.2 cu. ft. cargo area with rear seat folded down.
- Sturdy bolted, riveted and welded frame.

- Side door intrusion beams.
- Double-wall constructed front roof, hood, doors and tailgate.
- Extensive use of galvanized steel.
- 4-wheel anti-lock brake system.
- Impact-resistant halogen headlamps.
- Trailer Towing Package: includes trailer wiring harness; HD turn signal flasher; rear stabilizer bar; quad front and HD rear shock absorbers; HD 84 A.H. battery and super engine cooling.
- Three 4x4 systems available:



automatic locking front hubs; manual-locking hubs; and auto-locking hubs with Ford's exclusive Touch Drive electric shift transfer case option.

■ Well-equipped line of trim models, all covered in the 1995 Ford Bronco personal use brochure, available at your Ford Dealer.

*Based on model year manufacturers' reported retail deliveries by division through April, 1994.

NEW FORD RANGER PICKUP



The Ford tradition of building rugged and dependable work-tough trucks continues with the new 1995 Ranger.

Among the new features: a standard driver-side air bag to supplement the safety belts; and 4-wheel ABS brakes standard in the 4x4, optional in the 4x2 (rear ABS remains standard in the 4x2).

Ranger also includes:

- Choice of Regular Cab or roomier and more versatile SuperCab.

- Responsive 2.3-liter I-4, 3.0- and 4.0-liter V-6 engines with sequential multi-port fuel injection system.

- Choice of either standard 5-speed manual or optional electronic 4-speed automatic OD transmission.

- Regular Cab 4x2 carrying cargo up to 1,650 pounds, and the 4x4 model carrying up to 1,550 pounds, with the optional payload package #2.

- Twin-I-Beam (4x2) and Twin-Traction Beam (4x4) independent front suspensions.

- Choice of either electric shift 4x4 system (with fully automatic hub locks) or manual-locking front hubs.

- Double-wall construction for the hood, doors, all-welded pickup box side panels, and tailgate.

- Support pockets built into the pickup box inner side panels. With

two 2"x6" boards placed across them, you can take up to 500 lbs. of 4'x8' panels flat with the tailgate lowered.



DIMENSIONS

Wheelbase	Cab Length	Box Length at Cargo Floor	Box Width at Cargo Floor
107.9"	104.7"	72.2"	51.2"
113.9"	104.7"	84.2"	51.2"
125" SuperCab	120.9"	72.2"	51.2"
Load Height at Cargo Floor 4x2/4x4 (Empty)	Front Tread 4x2/4x4	Rear Tread 4x2/4x4	Axle Clearance 4x2/4x4
27.4"/29.0"	56.7"/58.3"	57.3"	6.1"/7.2"
27.4"/32.1"	56.7"/58.3"	57.3"	6.1"/7.2"
27.4"/31.3"	56.7"/58.3"	57.3"	6.1"/7.2"
Cargo volume (cu. ft.) (no allowance for wheelhouses)	Regular Cab	SuperCab	
Short wheelbase	37.4	—	
Long wheelbase	43.5	37.4	

New 1995 Ranger. It has all it takes, and then some, to make it once again America's top-selling compact pickup.

RANGER 4x2 SPECIFICATIONS

GVW Rating (max.)	4,700 lbs. - Regular Cab; 4,880 lbs. - SuperCab
Frame	Ladder-type
Axles: front	2,400 lbs. - Regular Cab; 2,625 - SuperCab
Axles: rear	Std. 2,750 lbs.; Opt. 2,750 lbs. Limited Slip
Computer-selected front coil springs (combined rating @ ground)	1,950 lbs. - Regular Cab; 2,150 lbs. - SuperCab
Computer-selected rear leaf springs (combined rating @ ground)	2,550 lbs. - Regular Cab; 2,550 lbs. - SuperCab
Shock absorbers	Std. gas-pressurized; Opt. heavy-duty gas-pressurized
Front stabilizer bar	Std.
Rear stabilizer bar	Opt. - Regular Cab and SuperCab*
Brakes	Std. power front discs; power rear drums with anti-lock system Opt. 4-wheel anti-lock brake system
Battery	58 AH maintenance-free - Regular Cab 72 AH maintenance-free - SuperCab (opt. in Regular Cab)
Alternator	95 amps
Fuel capacity	16.3 gals. - Regular Cab 20.0 gals. - SuperCab (opt. 19.6 gals. on 113.9" wb Regular Cab)
Steering: Regular Cab	Manual - std. in XL and XL Sport Power - included in XLT and STX; opt in XL and XL Sport
Steering: SuperCab	Power
Curb-to-curb turning diameter	36.5 ft. - 107.9" wb Regular Cab 38.3 ft. - 113.9" wb Regular Cab 41.6 ft. - 125" wb SuperCab

*Requires Handling Package.

POWERTEAMS AND AXLE RATIOS

Engines	Transmissions	Axle Ratios (Standard/Optional)		
		49 States	California	High Altitude
Regular Cab 4x2				
2.3L EFI I-4	5-Speed Man.	3.45/3.73*	3.45/3.73*	3.73
	4-Speed Auto.	3.73	3.73	—
3.0L EFI V-6	5-Speed Man.	3.45/3.73LS	3.45/3.73LS	3.45/3.73LS
	4-Speed Auto.	3.45/3.73LS	3.45/3.73LS	3.45/3.73LS
4.0L EFI V-6	5-Speed Man.	3.08/3.55LS	3.08/3.55LS	3.08/3.55LS
	4-Speed Auto.	3.08/3.55LS	3.08/3.55LS	3.08/3.55LS
Regular Cab 4x4				
2.3L EFI I-4	5-Speed Man.	4.10	4.10	4.10
	4-Speed Auto.	3.73/4.10LS	3.73/4.10LS	3.73/4.10LS
3.0L EFI V-6	5-Speed Man.	3.73/3.73LS	3.73/3.73LS	3.73/3.73LS
	4-Speed Auto.	3.73/4.10LS	3.73/4.10LS	3.73/4.10LS
4.0L EFI V-6	5-Speed Man.	3.27/3.73LS	3.27/3.73LS	3.73/3.73LS
	4-Speed Auto.	3.27/3.73LS	3.27/3.73LS	3.27/3.73LS
SuperCab 4x2				
2.3L EFI I-4	5-Speed Man.	3.73	3.73	3.73
	4-Speed Auto.	3.45/3.73LS	3.45/3.73LS	3.45/3.73LS
3.0L EFI V-6	5-Speed Man.	3.45/3.73LS	3.45/3.73LS	3.45/3.73LS
	4-Speed Auto.	3.45/3.73LS	3.45/3.73LS	3.45/3.73LS
4.0L EFI V-6	5-Speed Man.	3.08/3.55LS	3.08/3.55LS	3.08/3.55LS
	4-Speed Auto.	3.08/3.55LS	3.08/3.55LS	3.08/3.55LS
SuperCab 4x4				
3.0L EFI V-6	5-Speed Man.	3.73/3.73LS	3.73/3.73LS	3.73/3.73LS
	4-Speed Auto.	3.73/4.10LS	3.73/4.10LS	3.73/4.10LS
4.0L EFI V-6	5-Speed Man.	3.27/3.73LS	3.27/3.73LS	3.73/3.73LS
	4-Speed Auto.	3.27/3.73LS	3.27/3.73LS	3.27/3.73LS

LS = Optional Limited Slip rear axle. *3.45 axle with standard payload package; 3.73 axle included and available only with optional payload package #2.

RANGER 4x4 SPECIFICATIONS

GVW Rating (max.)	4,980 lbs. - Regular Cab; 5,120 lbs. - SuperCab
Frame	Ladder-type
Axles: front	2,850 lbs.
Axles: rear	Std. 2,750 lbs.; Opt. 2,750 lbs. Limited Slip
Computer-selected front coil springs (combined rating @ ground)	2,260 lbs. - Regular Cab; 2,340 lbs. - SuperCab
Computer-selected rear leaf springs (combined rating @ ground)	2,570 lbs. - Regular Cab; 2,750 lbs. - SuperCab
Shock absorbers	Heavy-duty gas-pressurized
Stabilizer bars	Std. - front and rear
Brakes	Power front discs/rear drums with 4-wheel anti-lock system
Front hubs/transfer case	Std. automatic locking/2-speed electric shift Opt. manual locking/2-speed manual shift
Battery	58 AH maintenance-free - Regular Cab 72 AH maintenance-free - SuperCab (opt. in Regular Cab)
Alternator	95 amps
Fuel capacity	16.3 gals. - Regular Cab 20.0 gals. - SuperCab (opt. 19.6 gals. on 113.9" wb Regular Cab)
Steering	Power
Curb-to-curb turning diameter (ft.)	37.3 ft. - 107.9" wb Regular Cab 39.1 ft. - 113.9" wb Regular Cab 42.4 ft. - 125" wb SuperCab

PAYLOAD PACKAGE SELECTOR

Regular Cab	Package No.	Payload	GVWR	Tires (Min.)
4x2 SWB	#1 Std.	1,250 lbs.	4,220 lbs.	P195/70R14SL
4x2 SWB	#2 Opt.	1,650 lbs.	4,680 lbs.	P215/70R14SL
4x2 LWB	#1 Std.	1,250 lbs.	4,260 lbs.	P195/70R14SL
4x2 LWB	#2 Opt.	1,650 lbs.	4,700 lbs.	P215/70R14SL
4x4 SWB	#1 Std.	1,250 lbs.	4,560 lbs.	P215/75R15SL
4x4 SWB	#2 Opt.	1,530 lbs.	4,960 lbs.	P215/75R15SL
4x4 LWB	#1 Std.	1,250 lbs.	4,620 lbs.	P215/75R15SL
4x4 LWB	#2 Opt.	1,550 lbs.	4,980 lbs.	P215/75R15SL
SuperCab				
4x2	#1 Std.	1,200 lbs.	4,500 lbs.	P195/70R14SL
4x2	#2 Opt.	1,550 lbs.	4,880 lbs.	P215/70R14SL
4x4	#1 Std.	1,250 lbs.	4,920 lbs.	P215/75R15SL
4x4	#2 Opt.	1,500 lbs.	5,100 lbs.	P215/75R15SL

SWB = short wheelbase (107.9" Regular Cab). LWB = long wheelbase (113.9" Regular Cab). Note: Payload is the maximum allowable weight of people, cargo, and body equipment and is reduced by the weight of optional equipment.

2.3-LITER I-4 ENGINE

Type/cylinders:	Gasoline/I-4, 8 plugs
Liters/cubic inches:	2.3/140
Fuel injection:	Sequential electronic
Bore and stroke:	3.78x3.13
Compression ratio:	9.2:1
Horsepower:	112 @ 4,800 rpm
Torque, lbs./ft.:	135 @ 2,400 rpm

3.0-LITER V-6 ENGINE

Type/cylinders:	Gasoline/V-6
Liters/cubic inches:	3.0/182
Fuel injection:	Sequential electronic
Bore and stroke:	3.50x3.14
Compression ratio:	9.4:1
Horsepower:	140 @ 4,800 rpm*
Torque, lbs./ft.:	160 @ 3,000 rpm*

*Latest horsepower and torque figures were not available at press time. See your Ford Dealer for up-to-date information.

4.0-LITER V-6 ENGINE

Type/cylinders:	Gasoline/V-6
Liters/cubic inches:	4.0/245
Fuel injection:	Sequential electronic
Bore and stroke:	3.95x3.32
Compression ratio:	9.0:1
Horsepower:	160 @ 4,200 rpm
Torque, lbs./ft.:	220 @ 3,000 rpm

FORD F-SERIES CHASSIS-CABS

There's an F-Series Chassis-Cab, in F-350 or F-Super Duty, to accommodate the custom body you need for your job.

F-Series Chassis-Cabs are *Built Ford Tough!* to handle most demanding light truck applications. And like the pickups, they have many of the design features noted on pages 4-5.

What's more, F-Series Chassis-Cabs offer the superior power and torque of the optional Power Stroke 7.3-liter turbo diesel. In fact, an F-Super Duty Chassis-Cab powered by the Power Stroke turbo diesel with automatic transmission and 5.13 axle ratio has a 22,000-lbs. Gross Combination Weight Rating (GCWR)—the highest in its class.

F-350 CHASSIS-CABS

The F-350 Regular Chassis-Cab is available in 2-wheel drive and 4-wheel drive, in single rear wheel (SRW) and dual rear wheel (DRW) configurations, with three wheelbases of 133" (SRW), 137" and 161" (DRW).

The F-350 Chassis-Cab is now available also in SuperCab and Crew Cab styles with the Pickup Box Delete option specified.* See your Ford Dealer for complete details.

Principal features of the F-350 Chassis-Cabs include:

- Maximum Gross Vehicle Weight Rating (GVWR) of 11,000 pounds.
- Maximum payloads of 6,425 pounds in the DRW F-350 4x2 and 5,760 pounds in the DRW F-350 4x4, both with 137" wheelbase and dual fuel tanks.

■ In the 4x2: standard 4.9L I-6; optional 5.8L and 7.5L V-8 gas engines, all with multi-port electronic fuel injection; optional Power Stroke 7.3L turbo diesel.

■ In the 4x4: standard 7.5L V-8; optional Power Stroke 7.3L turbo diesel.

■ Three transmissions: standard HD 5-speed manual; optional 3-speed automatic; and optional electronic 4-speed automatic overdrive (E4OD).

■ Twin-I-Beam independent front suspension (4x2); rugged monobeam front axle and leaf springs (4x4).

■ Single stage, constant-rate rear leaf main springs with auxiliary springs standard.

■ Twin-tube, nitrogen gas-pressurized shock absorbers for ride quality and control.

■ Power brakes. And a computer-controlled rear anti-lock system designed to inhibit braking-induced rear wheel lockup under most operating conditions.

■ Automatic-locking 4x4 front hubs standard; manual-locking front hubs available.

F-SUPER DUTY CHASSIS-CAB

The F-Super Duty Chassis-Cab is designed to fill the gap between the F-350 and Ford's line of medium-duty trucks.

It's available in 2-wheel drive with dual rear wheels. And there are three wheelbases: 137", 161", and 185".

F-Super Duty Chassis-Cab features include:

■ Maximum GVW rating of 15,000 pounds.

■ Maximum payload of 9,575 pounds with 137" wheelbase and dual fuel tanks.

■ Standard 7.5L V-8; optional Power Stroke 7.3L turbo diesel.

■ Rugged monobeam front axle.

■ Front and rear single stage constant-rate leaf springs.

Auxiliary rear springs are standard.

■ Twin-tube, nitrogen gas-pressurized shock absorbers.

■ Four-wheel disc brakes.

F-350 HEAVY-DUTY FRONT SUSPENSION PACKAGE

F-350 4x4 with 133" wheelbase includes:

■ 4,800-lbs. GAWR.

■ 5,000-lbs. HD springs.

F-350 4x4 with 137" or 161" wheelbase includes:

■ 5,000-lbs. GAWR.

■ 5,000-lbs. HD springs.

F-350 4x2 dual-rear-wheel Chassis-Cab includes:

■ 4,000-lbs. GAWR.

■ 4,000-lbs. HD springs.

The Heavy-Duty Front Suspension Package is recommended on vehicles which will permanently utilize aftermarket equipment such as snow plows, heavy-duty winches and others that load the front axle to the specified Gross Axle Weight Rating (GAWR).

OPTIONAL FEATURES

Major F-350 and F-Super Duty Chassis-Cab options available within all trim levels include:

- Knit vinyl bench seat.
- Air conditioning.
- Spare tire and wheel.
- Sliding rear window.
- Tachometer.
- Super engine cooling.
- Engine block heater.
- Single fuel tank.
- Auxiliary fuel tap.
- HD battery for F-350.
- HD front suspension package for F-350 (contents listed at left).
- Front license plate bracket.

F-350 AMBULANCE PREP PACKAGE*

- 137"/161" wheelbases.
- 11,000-lbs. GVWR.
- 4,400-lbs. front GAWR (4x2).
- 4,800-lbs. front GAWR (4x4).
- Wide-track rear axle with 4.10 limited slip ratio; conventional-track axle with 4.10 or 4.10 limited-slip may be substituted.
- 215-amp alternator.
- Handling package: front and rear stabilizer bars.
- Air conditioning.
- Requires the Power Stroke 7.3L turbo diesel.

F-SUPER DUTY AMBULANCE PREP PACKAGE*

- 15,000-lbs. GVWR.
- 5,000-lbs. front GAWR.
- 215-amp alternator.
- Air conditioning.
- Requires the Power Stroke 7.3L turbo diesel.

*Incomplete vehicle package — requires further manufacture and certification by a final-stage manufacturer. In addition, Ford urges all manufacturers to follow the recommendations of the Ford Incomplete Vehicle Manual and the Ford Truck Body Builder's Layout Book (and pertinent supplements). Also note, Ford vehicles are suitable for completion as ambulances only if equipped with the Ford Ambulance Preparation Package. Using a Ford vehicle without the Ford Ambulance Preparation Package to produce an ambulance voids the Ford Warranty.

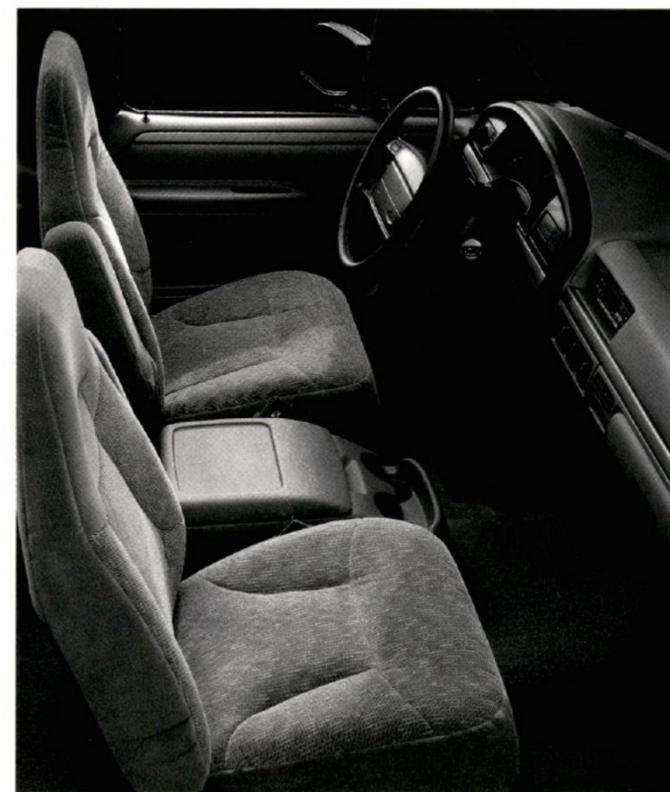

FORD F-SERIES CHASSIS-CAB SPECIFICATIONS



IMPORTANT INFORMATION

Many of the items shown on vehicles in this publication are available through retail organizations and establishments not connected with Ford Motor Company. Availability, price, quality, and durability of these items rest solely with the respective manufacturers and their sales organizations, and Ford assumes no responsibility for their use.

ABOUT PICKUP BOX REMOVAL

Ford provides guidelines for the removal of pickup box and installation of certain other aftermarket truck body equipment. See the 1995 Ford Truck Body Builder's Layout Book for details.

DIMENSIONS

Series	Wheelbase	Overall Length	Cab-Rear Axle Length	Rear Axle-Frame Length	Frame Height (Empty/Loaded)	Axle Height (Loaded)	Tread Width (Front/Rear)	Cab Height (Empty)
F-350 4x2 SRW	133"	207.0"	56.2"	40.5"	26.0"/20.5"	8.34"	65.7"/64.3"	74.3"
F-350 4x2 DRW	137" 161"	208.8" 241.9"	60.0" 84.0"	38.5" 47.5"	23.1"/20.4" 23.1"/20.4"	7.74" 7.74"	65.7"/67.1" 65.7"/67.1"	73.5" 73.2"
F-350 4x4 SRW	133"	207.0"	56.2"	40.5"	24.2"/20.2"	8.34"	67.9"/64.3"	78.7"
F-350 4x4 DRW	137" 161"	208.8" 241.9"	60.0" 84.0"	38.5" 47.5"	27.8"/25.1" 27.8"/25.1"	8.34" 8.34"	67.9"/67.1" 67.9"/67.1"	78.0" 78.0"
F-Super Duty 4x2 DRW	137" 161" 185"	208.8" 241.9" 265.8"	60.0" 84.0" 108.0"	38.5" 47.5" 47.5"	26.3"/23.5" 26.3"/23.5" 28.1"/23.8"	7.76" 7.76" 7.76"	67.0"/69.7" 67.0"/69.7" 67.0"/69.7"	77.5" 77.5" 77.5"

SRW = Single Rear Wheels. DRW = Dual Rear Wheels.

4x2 F-SERIES CHASSIS-CABS: TWIN-I-BEAM FRONT AXLE

	F-350 4x2 SRW	F-350 4x2 DRW
Wheelbase (in.):	133	137
GVWR (lbs.):	8,800	10,000
		Opt. 11,000
Payload (lbs.):	4,670	5,555
		Opt. 6,425
Front axle (lbs.):	4,200	4,200
Rear axle (lbs.):	6,250	8,250
Front springs: (combined rating @ ground)	2,915	3,365
Rear springs: (combined rating @ ground)	7,813	8,358
Fuel tank (gals.):	37.2 dual Opt. 18.2 single	38 dual Opt. 19 single
Tires:	Four LT235/85R16E all-season	Six LT215/85R16D all-season 8-hole disc/16"x6"K
Wheels:	8-hole disc/16"x7"K	8-hole disc/16"x6"K
Shock absorbers:	Twin-tube, nitrogen gas-pressurized	
Battery:	Std. 72 amp-hr. Opt. 84 amp-hr. Dual 84 amp-hr. std. with 7.3L turbo diesel	
Alternator:	95 amps with gas engines; 130 amps with 7.3L turbo diesel	
Steering:	Power	
Brakes:	Power front disc and rear drum with rear anti-lock	

SRW = Single Rear Wheels. DRW = Dual Rear Wheels. Note: Load rating represents maximum allowable weight of people, cargo and body equipment, and is reduced by weight of optional equipment. Payloads can be increased if the single-fuel tank option is ordered. See your dealer for more information.

POWERTEAMS

Engines	Twin-I-Beam Front Axle		Monobeam Front Axle		
	F-350 4x2 SRW	F-350 4x2 DRW	F-350 4x4 SRW	F-350 4x4 DRW	F-Super Duty 4x2 DRW
4.9L EFI I6*	S	S	-	-	-
5.8L EFI V-8*	O	O	-	-	-
7.5L EFI V-8	O	O	S	S	S
7.3L Turbo Diesel	O	O	O	O	O
Transmissions					
5-spd. manual overdrive HD	S	S	S	S	S
3-spd. auto.	O	O	O	O	-
Electronic 4-spd. auto. overdrive [E4OD]	O	O	O	O	O

SRW = Single Rear Wheels. DRW = Dual Rear Wheels. *Not available in California. †Not available with 11,000-lb. GVWR.

4x4 F-SERIES CHASSIS-CABS: MONOBEAM FRONT AXLE

	F-350 4x4 SRW	F-350 4x4 DRW
Wheelbase (in.):	133	137
GVWR (lbs.):	8,800	11,000
Payload (lbs.):	3,915	5,760
Front axle (lbs.):	5,000	5,000
Rear axle (lbs.):	6,250	8,250
Front springs: (combined rating @ ground)	4,100	4,100
Rear springs: (combined rating @ ground)	7,596	8,427
Fuel tank (gals.):	37.2 dual Opt. 18.2 single	38 dual Opt. 19 single
Tires:	Four LT235/85R16E all-season	Six LT235/85R16E all-season
Wheels:	8-hole disc/16"x7"K	8-hole disc/16"x6"K
Shock absorbers:	Twin-tube, nitrogen gas-pressurized	
Battery:	Std. 72 amp-hr. Opt. 84 amp-hr. Dual 84 amp-hr. std. with 7.3L turbo diesel	
Alternator:	95 amps; 130 amps with 7.3L turbo diesel	
Steering:	Power	
Brakes:	Power front disc and rear drum with rear anti-lock system	

SRW = Single Rear Wheels. DRW = Dual Rear Wheels. Note: Load rating represents maximum allowable weight of people, cargo and body equipment, and is reduced by weight of optional equipment. Payloads can be increased if the single-fuel tank option is ordered. See your dealer for more information.

4x2 F-SUPER DUTY CHASSIS-CABS: MONOBEAM FRONT AXLE

	F-Super Duty 4x2 DRW
Wheelbase (in.):	137
GVWR (lbs.):	15,000
Payload (lbs.):	9,575
Front axle (lbs.):	5,000
Rear axle (lbs.):	11,000
Front springs: (combined rating @ ground)	5,000
Rear springs: (combined rating @ ground)	11,000
Fuel tank (gals.):	38 dual Opt. 19 single
Tires:	Six LT235/85R16E all-season
Wheels (type/rim size):	10-hole disc/16"x6"K
Shock absorbers:	Twin-tube, nitrogen gas-pressurized
Battery:	Std. 84 amp-hr. Dual 84 amp-hr. std. with 7.3L turbo diesel
Alternator:	95 amps; 130 amps with 7.3L turbo diesel
Steering:	Power
Brakes:	Power 4-wheel disc

DRW = Dual Rear Wheels. Note: Load rating represents maximum allowable weight of people, cargo and body equipment, and is reduced by weight of optional equipment. Payloads can be increased if the single-fuel tank option is ordered. See your dealer for more information.

FORD ECONOLINE AND F-SUPER DUTY STRIPPED CHASSIS

ECONOLINE

The Econoline Stripped Chassis for commercial applications comes without the body, driver's compartment and front end sheet metal, allowing you to add an aftermarket body of your choice.

The Commercial Stripped Chassis is offered in single- or dual-rear-wheel models and is powered by the standard 4.9L EFI I-6. The 5.8L EFI V-8 is optional.

F-SUPER DUTY

The F-Super Duty Stripped Chassis is available for Class A motorhome applications.

The 17,000-lbs. GVWR Motorhome Stripped Chassis comes in 178", 190", 208" and 228" wheelbases. It's powered by a 7.5L V-8 with the E4OD transmission.

ECONOLINE STRIPPED CHASSIS SPECIFICATIONS

Series		Commercial E-350 SRW/DRW
GVWR range (lbs.)		9,400/10,000
Payload Range (lbs.)		5,605/6,060
Axles (lbs.)	Front:	4,600
	Rear:	6,340 (SRW), 7,800 (DRW)
Springs (combined rating @ ground)	Front:	3,550
	Rear:	7,810
Steering	Power	
Brakes	Power w/rear anti-lock	
Battery (amp-hr.)	72	
Alternator (amp.)	95	
Engines	Standard:	4.9L EFI I-6*
	Optional:	5.8L EFI V-8*
		7.5L EFI V-8**
Transmissions	Standard:	3-speed automatic
	Optional:	4-speed automatic E4OD
Fuel tank (gal.)	35.0	
Tires	LT245/75R16E (SRW) LT225/75R16D (DRW)	
Wheels (number)	Four 8-hole disc 16"x7"K (SRW)	
Type/rim size	Six 8-hole disc 16"x6"K (DRW)	

Note: Load rating represents maximum allowable weight of people, cargo and body equipment, and is reduced by weight of optional equipment. *Not available in California. **See your Ford Dealer for availability.

ECONOLINE DIMENSIONS

E-350	WB	OAL	Rear Wheels	FH Loaded
Commercial	138"	235.5"	Single	20.7"
Stripped	138"	235.5"	Dual	20.2"
Chassis	158"	255.5"	Single	20.7"
	158"	255.5"	Dual	20.2"
	176"	255.5"	Dual	20.2"

WB=Wheelbase. OAL=Overall Length. FH=Frame Height at rear axle.

F-SERIES DIMENSIONS

F-Super Duty 4x2	WB	OAL	RAF Length	FH (Empty/Loaded)	AH (Loaded)	TW (Front/Rear)
Motorhome	178"	320.3"	105.8"	32.8/27.4"	7.6"	71.7/71.7"
Stripped Chassis	190"	332.3"	105.8"	32.8/27.4"	7.6"	71.7/71.7"
	208"	350.3"	105.8"	32.8/27.4"	7.6"	71.7/71.7"
	228"	370.3"	105.8"	32.8/27.4"	7.6"	71.7/71.7"

WB=Wheelbase. OAL=Overall Length. RAF=Rear Axle Frame. FH=Frame Height at rear axle. AH=Axle Height. TW=Tread Width.



F-SERIES STRIPPED CHASSIS SPECIFICATIONS

Series		Motorhome Stripped Chassis 4x2 DRW	
Wheelbase (in.)		178/190/208/228	178/190
GVWR (lbs.)		17,000	15,200
Payload (lbs.)		11,170/11,050/11,025/10,945	9,370/9,250
Axles (lbs.)	Front:	6,000 monobeam	6,000 monobeam
	Rear:	11,000	11,000
Springs (combined rating @ ground)	Front:	6,000	6,000
	Rear:	11,000	11,000
Steering and Brakes		Power	Power
Battery (amp-hr.)		72 (maintenance-free)	72 (maintenance-free)
Alternator (amp.)		130	130
Engine		7.5L EFI V-8	7.5L EFI V-8
Transmission	Standard:	4-spd. automatic E4OD	4-spd. automatic E4OD
	Optional:	-	-
Fuel tank (gal.)		75 single	75 single
Tires (all season)		Six LT235/85R16E	Six LT215/85R16E
Wheels (type/rim size)		Seven 10-hole disc, 16"x6"K	Seven 10-hole disc, 16"x6"K

The F-Super Duty Motorhome Stripped Chassis is detailed here. Rugged engineering features include:

- 1** The frame side rails are straight. And the top of the frame is smooth and rivet-free for convenient body installation.
- 2** The rugged monobeam front axle is of forged steel construction.
- 3** #2 and #3 crossmembers bolt in and out for transmission and engine servicing.
- 4** Crossmembers are single-piece stampings, not riveted assemblies.
- 5** Tapered leaf springs are extra long and wide for toughness and comfort. Rated capacity is 6,000 lbs.
- 6** Brake lines, fuel lines and wiring are mounted between the frame rails for protection.
- 7** Rear leaf springs are 64 inches long for ride comfort. Rated capacity is 11,000 lbs.
- 8** Spring mounting brackets are cast steel, not stamped steel. The rear spring front mounting bracket has a bolted, double crossmember for strength.
- 9** Heavy-duty shock absorbers are nitrogen gas-pressurized for ride comfort and control.
- 10** Large-diameter front and rear stabilizer bars contribute to ride control.
- 11** 16-inch metric radial tires contribute to fuel efficiency by reducing rolling resistance.

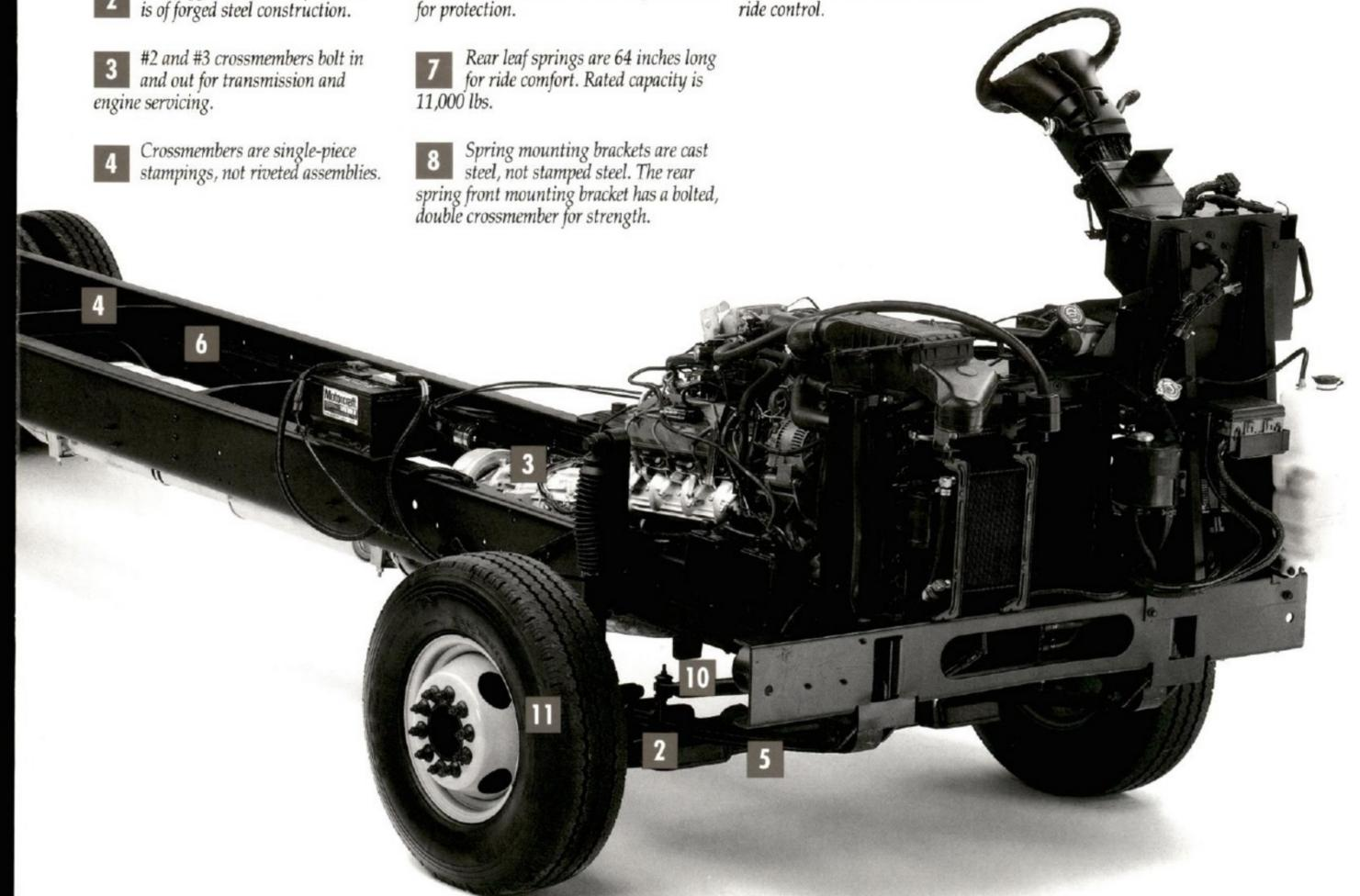

TRAILER TOWING

You'll find here basic information for trailer towing. For more information, see the 1995 Ford Recreation Vehicle and Towing Guide.

TRAILER CLASSES AND HITCHES

Class I Light Duty:

- 2,000-lbs. gross trailer weight (trailer and cargo).
- Load-carrying (non-equalizing) hitch.

Class II Medium Duty:

- 2,001 to 3,500-lbs. gross trailer weight.
- Load-equalizing hitch required (except with step bumper on F-Series, Bronco).

Class III Heavy-Duty:

- 3,501 to 5,000-lbs. gross trailer weight.
- Load-equalizing hitch required (except with step bumper on F-Series, or with step bumper on Bronco towing up to 4,000 lbs.).

Class IV Extra Heavy-Duty:

- 5,001 to 10,000-lbs. gross trailer weight; up to 12,500 lbs. with F-250HD and F-350 with fifth wheel trailer.
- Load-equalizing hitch or fifth wheel required.

REQUIRED EQUIPMENT

For Ranger towing over 2,000 lbs.:

- Super engine cooling or air conditioning.
- Payload Package #2 with Regular Cab models.

For Bronco towing over 2,000 lbs.:

- Trailer Towing Package.

For F-Series towing 2,000 to 3,500 lbs.:

- Super engine cooling or Trailer Towing Package.

For F-Series towing over 3,500 lbs.:

- Super engine cooling with Handling Package or Trailer Towing Package.

TRAILER TOWING PACKAGES

For F-150 and F-250:

- Super engine cooling.
- Trailer wiring harness.
- HD turn signal flasher.
- HD battery (84 amp-hr.).
- Handling package:

front and rear stabilizer bars; HD front and rear shock absorbers (SuperCab 4x4); quad front and HD rear shock absorbers (Regular Cab 4x4).

For F-250HD and F-350:

- Super engine cooling.
- Trailer wiring harness.
- HD turn signal flasher.
- HD battery (84 amp-hr. with gas engines).
- Handling package:

front and rear stabilizer bars. Note: High-capacity rear springs will be substituted for front and rear stabilizer bars on F-250HD 4x4s with the optional Power Stroke 7.3L turbo diesel.

For Bronco:

- Trailer wiring harness.
- HD turn signal flasher.
- Rear stabilizer bar (front is standard).
- Quad front and HD rear shock absorbers.
- HD 84 amp-hr. battery.
- Super engine cooling.

STYLESIDE RANGER MAXIMUM TRAILER WEIGHTS*

Automatic	Axle Ratio	GCWR Max.	Regular Cab		SuperCab	
			4x2	4x4	4x2	4x4
2.3L EFI I-4	3.73	5,500	2,300	-	-	-
3.0L EFI V-6	3.45	7,000	3,700	-	-	-
	3.73	7,500	4,000	3,900	4,000	3,600
	4.10	8,000	-	4,400	-	4,100
4.0L EFI V-6	3.08	6,000	2,700	-	2,400	-
	3.27	7,500	-	3,800	-	3,600
	3.55	9,500	6,000	-	5,900	-
	3.73	9,500	-	5,800	-	5,600

Manual

2.3L EFI I-4	3.73	4,800	1,600	-	1,300	-
	4.10	4,800	-	1,300	-	-
3.0L EFI V-6	3.45	5,000	1,800	-	1,500	-
	3.73	6,000	2,800	2,400	2,500	2,100
4.0L EFI V-6	3.08	5,000	1,700	-	1,500	-
	3.27	6,000	-	2,000	-	2,000
	3.55	7,000	3,700	-	3,400	-
	3.73	7,000	-	3,400	-	3,000

*See your Ford Dealer for trailer towing weights for Splash model or Styleside models equipped with Splash sport suspension.

F-SERIES CHASSIS-CAB AND STRIPPED CHASSIS MAXIMUM TRAILER WEIGHTS WITH FIFTH WHEEL

Automatic	Axle Ratio	GCWR Max.	F-350 4x2 SRW	F-350 4x4 SRW	F-350 4x2 DRW	F-350 4x4 DRW	F-Super Duty 4x2
4.9L EFI I-6	4.10	11,000	6,600	-	6,200	-	-
5.8L EFI V-8	3.55	11,500	6,900	-	6,600	-	-
	4.10	13,000	8,400	-	8,000	-	-
Power Stroke 7.3L turbo diesel ⁽¹⁾	3.55	16,000	10,900	10,400	-	-	-
	4.10	20,000	12,500	12,500	12,500	12,500	-
	5.13	22,000	-	-	-	-	12,500
7.5L EFI V-8	3.55	15,000	10,300	9,800	-	-	-
	4.10	18,500	12,500	12,500	12,500	-	-
	4.63	22,000	-	-	-	-	12,500
	5.13	26,000 ⁽²⁾	-	-	-	-	12,500 ⁽²⁾

Manual

4.9L EFI I-6	4.10	10,000	5,600	-	5,200	-	-
5.8L EFI V-8	3.55	11,500	7,000	-	-	-	-
	4.10	13,000	8,500	-	8,000	-	-
Power Stroke 7.3L turbo diesel ⁽¹⁾	3.55	14,500	9,400	8,900	-	-	-
	4.10	17,000	11,900	11,400	10,900	-	-
	5.13	19,000	-	-	-	-	12,500
7.5L EFI V-8	3.55	12,000	7,300	6,800	-	-	-
	4.10	16,000	11,300	10,800	10,400	-	-
	4.63	22,000	-	-	-	-	12,500
	5.13	26,000	-	-	-	-	12,500

(1) Vehicles equipped with Ambulance Preparation Package are not available for towing.

(2) 25,000-lbs. GCWR, 8000 lbs. maximum trailer weight at 17,000 lbs. GVWR with F-Super Duty Motorhome Stripped Chassis.

Note: Engine/axle ratio combinations may not be available in all areas. See your dealer for availability information. Trailer weights shown must be reduced by passenger and cargo weight in the towing vehicle. Maximum trailer weights are shown. The combined weight of the towing vehicle (including passengers, hitch and cargo) and the loaded trailer must not exceed the Gross Combined Weight Rating.

F-SERIES MAXIMUM TRAILER WEIGHTS

Automatic	Axle Ratio	GCWR Max.	Regular Cab						SuperCab				Crew Cab			Bronco	
			F-150 4x2	F-150 4x4	F-250 4x2	F-250 HD4x2	F-250 HD4x4	F-350 4x4	F-350 DRW 4x2	F-150 4x2	F-150 4x4	F-250 HD4x2	F-250 HD4x4	F-350 DRW 4x2	F-350 DRW 4x2	F-350 4x4	4x4
4.9L EFI I-6	3.08	9,000	4,600	(1)	-	-	-	-	4,300	-	-	-	-	-	-	-	-
	3.31	9,500	5,100	-	-	-	-	-	4,800	-	-	-	-	-	-	-	-
	3.55	10,000	5,600	5,300	5,300	-	-	-	5,300	-	-	-	-	-	-	-	-
	4.10	11,000	-	-	-	6,200	-	-	-	-	6,000	-	-	-	-	-	-
5.0L EFI V-8	3.08	9,000	4,700	-	-	-	-	-	-	-	-	-	-	-	-	-	-
	3.31	11,500	-	6,900	-	-	-	-	-	-	6,700	-	-	-	-	-	-
	3.55	11,500	7,100	6,800	-	-	-	-	6,800	6,600	-	-	-	-	-	-	6,600
	4.10	12,500	-	-	7,800	-	-	-	-	-	-	-	-	-	-	-	-
5.8L EFI V-8	3.08	10,000	5,500	5,200	-	-	-	-	5,300	-	-	-	-	-	-	-	-
	3.55	11,500	-	-	6,700	6,500	6,200	6,200	6,400	-	-	6,300	5,900	6,100	5,800	5,600	-
	3.55	12,000	7,500	7,200	-	-	-	-	7,300	7,100	-	-	-	-	-	-	7,000
	4.10	13,000	-	-	8,200	8,000	7,700	7,700	7,800	-	-	7,800	7,400	7,500	7,300	7,100	-
Power Stroke 7.3L turbo diesel	3.55	16,000	-	-	-	10,000	10,000	10,000	-	-	-	10,000	10,000	-	9,900	-	9,400
	4.10	20,000	-	-	-	10,000	10,000	10,000	10,000	-	-	10,000	10,000	10,000	10,000	10,000	-
7.5L EFI V-8	3.55	15,000	-	-	-	9,900	9,600	9,500	-	-	-	9,600	9,300	-	9,300	-	8,900
	4.10	18,500	-	-	-	10,000	10,000	10,000	10,000	-	-	10,000	10,000	10,000	10,000	10,000	-

Manual

4.9L EFI I-6	2.73	6,250	(1)	-	-	-	-	-	-	-	-	-	-	-	-	-	-
	3.08	6,450	2,100	1,900	-	-	-	-	1,900	1,600	-	-	-	-	-	-	-
	3.31	7,125	2,800	2,500	-	-	-	-	2,600	2,300	-	-	-	-	-	-	-
	3.55	7,800	3,500	3,200	3,200	-	-	-	3,200	3,000	-	-	-	-	-	-	-
	4.10	10,000	-	-	-	5,200	-	-	-	-	-	-	-	-	-	-	-
5.0L EFI V-8	3.08	6,450	2,200	-	-	-	-	-	-	-	-	-	-	-	-	-	-
	3.55	7,800	3,500	3,200	3,200	-	-	-	3,200	3,000	-	-	-	-	-	-	3,000
	4.10	10,000	-	-	5,400	-	-	-	-	-	-	-	-	-	-	-	-
5.8L EFI V-8	3.55	11,500	-	-	-	6,500	6,200	6,200	-	-	-	6,300	6,000	-	-	-	-
	4.10	13,000	-	-	-	8,000	7,700	7,700	7,800	-	-	7,800	7,500	-	7,500	7,300	7,100
Power Stroke 7.3L turbo diesel	3.55	14,500	-	-	-	8,900	8,600	8,500	-	-	-	8,700	8,300	-	8,400	-	7,900
	4.10	17,000	-	-	-	10,000	10,000	10,000	0,000	-	-	10,000	10,000	10,000	10,000	10,000	10,000
7.5L EFI V-8	3.55	12,000	-	-	-	6,900	6,600	6,500	-	-	-	6,700	6,300	-	6,300	-	5,900
	4.10	16,000	-	-	-	10,000	10,000	10,000	0,000	-	-	10,000	10,000	10,000	10,000	10,000	9,900

(1) Not available for trailer towing.

F-SERIES MAXIMUM TRAILER WEIGHTS WITH FIFTH WHEEL

Automatic	Axle Ratio	GCWR Max.	Regular Cab						SuperCab				Crew Cab				
			F-150 4x2	F-150 4x4	F-250 4x2	F-250 HD4x2	F-250 HD4x4	F-350 4x4	F-350 DRW 4x2	F-150 4x2	F-150 4x4	F-250 HD4x2	F-250 HD4x4	F-350 DRW 4x2	F-350 DRW 4x2	F-350 4x4	
4.9L EFI I-6	3.08	9,000	4,600	(1)	-	-	-	-	4,300	-	-	-	-	-	-	-	-
	3.31	9,500	5,100	-	-	-	-	-	4,300	-	-	-	-	-	-	-	-
	3.55	10,000	5,600	5,300	5,300	-	-	-	5,300	-	-	-	-	-	-	-	-
	4.10	11,000	-	-	-	6,200	-	-	-	-	6,000	-	-	-	-	-	-
5.0L EFI V-8	3.08	9,000	4,700	-	-	-	-	-	-	-	-	-	-	-	-	-	-
	3.31	11,500	-	6,900	-	-	-	-	-	-	6,700	-	-	-	-	-	-
	3.55	11,500	7,100	6,800	-	-	-	-	6,800	6,600	-	-	-	-	-	-	-
	4.10	12,500	-	-	7,800	-	-	-	-	-	-	-	-	-	-	-	-
5.8L EFI V-8	3.08	10,000	5,500	5,200	-	-	-	-	5,300	-	-	-	-	-	-	-	-
	3.55	11,500	-	-	6,700	6,500	6,200	6,200	6,400	-	-	6,300	5				

BUMPER-TO-BUMPER COVERAGE

The 3-year/36,000-mile bumper-to-bumper coverage of Ford's new vehicle limited warranty covers the complete vehicle (except tires, battery, service adjustments and other items covered under separate provisions) against defects in factory-supplied materials or workmanship.

For complete information, see your Ford Dealer.

ROADSIDE ASSISTANCE PROGRAM

Every new Ford includes the assurance of an emergency Roadside Assistance Program provided by Ford Auto Club, Inc. during the 3-year/36,000-mile bumper-to-bumper warranty period. Help is a toll-free phone call away, 24 hours a day, anywhere in the 50 United States, should you need any towing assistance, fuel delivery, tire change, a jump start, or even help when you're locked out of your truck. Ask your Ford Dealer for complete details on the Ford Roadside Assistance Program and a copy of the limited warranty.

FORD CITIBANK CREDIT CARD

Using your Ford Citibank Visa® or MasterCard® could earn you hundreds, even thousands of dollars from Ford toward the purchase or lease of a new Ford, Lincoln or Mercury product. To apply or get more information, call

1-800-374-7777. Or visit a Ford or Lincoln-Mercury dealer, or a branch office of Citibank.



Ford Credit is a full service company that makes a wide variety of financing and leasing programs available to qualified buyers through the Ford Dealer of your choice. Through Ford Credit's financing or Red Carpet leasing, arrangements suited to your special needs can be made quickly and conveniently right at the dealership. Ask your Ford Dealer for the facts on any of Ford Credit's financing or lease plans.



Optional Ford Extended Service Plans can cover major components on new Ford cars and light trucks for longer than the vehicle's basic warranty. Your Ford Dealer has full details.

FEDERAL REGULATIONS

Federal regulations such as those issued by the National Highway Traffic Safety Administration, the Environmental Protection Agency or the Federal Highway Administration, or issued pursuant to the Occupational Safety and Health Organization (OSHA) and/or state and local laws and regulations, may require additional equipment for the particular use you intend for the vehicle. It is the buyer's responsibility to determine the

applicability of such laws and regulations to the buyer's intended use for the vehicle and to arrange for the installation of required equipment. Your dealer has information about the availability of many items of equipment which can be ordered for the vehicle.

IMPORTANT INFORMATION

Many of the items shown on vehicles in this publication are available through retail organizations and establishments not connected with Ford Motor Company. Availability, price, quality and durability of these items rest solely with the respective manufacturers and their sales organizations; Ford assumes no responsibility for their use.

PRODUCT CHANGES

Following publication of this catalog, certain changes in standard equipment, options, prices and the like, or product delays, may have occurred which would not be included in these pages. Your Ford Dealer is your best source for up-to-date information. Ford Division reserves the right to change product specifications at any time without incurring obligations.

OPTIONS AVAILABILITY

Options shown or described are available at extra cost and may be offered only in combination with other options or subject to additional ordering requirements or limitations.

