

1995 FORD

WINDSTAR



WINDSTAR LX

The all-new front-wheel-drive Ford Windstar establishes a whole new standard by which all others will be judged. It is indeed the *future* of minivans.

The unique design is longer and wider for better maneuverability and more interior space. The flow-through instrument panel puts controls within easy reach. But the true joy of the new Windstar is revealed on the road. The car-like ride is the smoothest in its class. It's a confident, *secure* driving experience.

Because safety is so important, Windstar has more standard safety features than any other minivan. These include an air bag to supplement the safety belts for both the driver

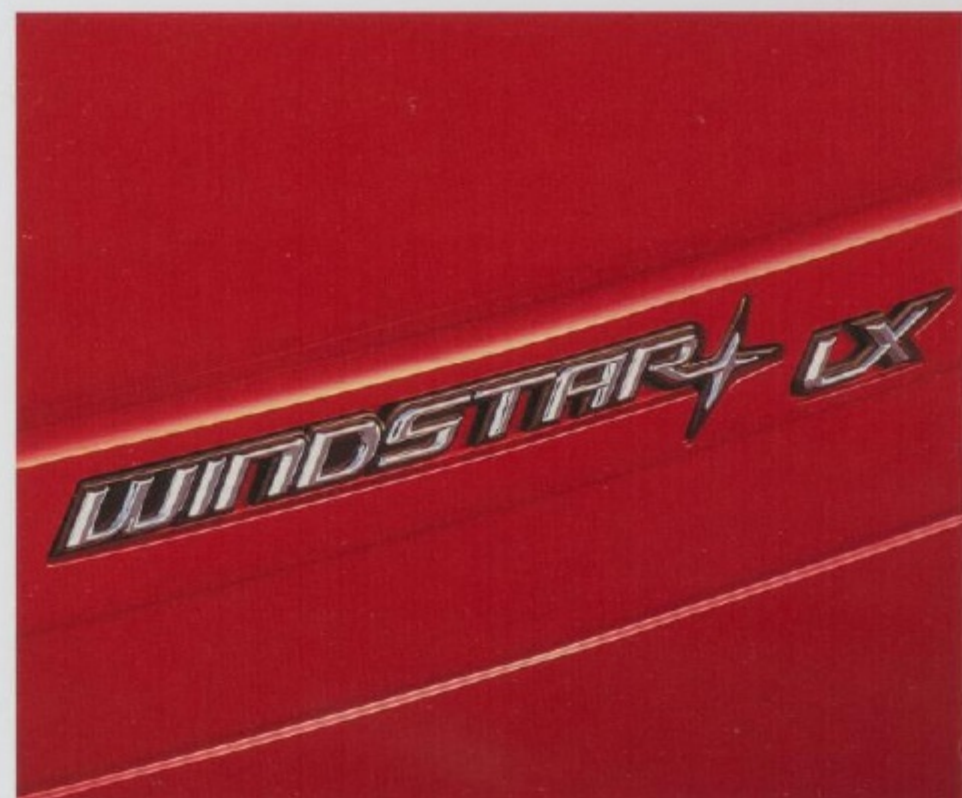

and the front passenger, a 4-wheel anti-lock braking system, a front-end "crush zone" and side door intrusion beams.

And Windstar's acoustical design promotes a quiet ride so that conversation among all passengers can be carried on at normal levels.

The finest expression of the new

WINDSTAR WILL
FOREVER CHANGE
THE WAY YOU
THINK ABOUT
FAMILY VEHICLES.
THE FUTURE OF
MINIVANS
BEGINS TODAY.

Windstar is the well-appointed LX. Its 7-passenger seating includes premium cloth upholstery and a 6-way power driver's seat. Air conditioning is standard, as are power remote-control mirrors, AM/FM stereo cassette, power locks and windows, a cargo net and other features that add to the pleasure of driving the future of the minivan — Ford Windstar.









WINDSTAR GL



The Windstar GL model is generously equipped to offer solid passenger comfort as well as an impressive complement of convenience features.

Air bags for both the driver and the front passenger (but remember to always wear your safety belt) and a 4-wheel anti-lock brake system head a long list of standard equipment. Solar tinted glass all around. Dual outside mirrors (right-hand convex). A rear window wiper. Variable-interval front

wipers. Full-length 13-oz. color-keyed carpeting. Cup-holders. Storage bins. A cloth headliner. Full instrumentation including tachometer. A sliding side door with childproof lock (shown at left). An AM/FM stereo radio with 4 premium speakers and controls for 2nd-row passengers (including two headphone jacks). Full 7-passenger seating with cloth upholstery — all are included with the Windstar GL.

A RANGE OF CHOICE

By choosing Preferred Equipment Packages, you can add desirable items to your GL and take advantage of package discounts, too. PEP 472A, for example, includes an electric rear window defroster, power windows, locks and mirrors, an electronic AM/FM stereo with cassette, and speed control/tilt steering wheel. See page 24 for a complete list of PEP contents.



Windstar GL shown in Royal Blue Clearcoat Metallic with Preferred Equipment Package 472A.

RIDE & HANDLING

One of the most pleasant aspects of new front-wheel-drive Windstar becomes apparent the moment you start down the road. Innovative design stretched the wheelbase. The result is a ride that's

unexpectedly smooth, more of what you would expect from a car. Windstar has, in fact, the smoothest ride among all minivans. And that's not just an opinion.

During the development process, ride data from Windstar and competing minivans were compared using *ride histograms*, which are technologically sophisticated measurements that quantify ride quality. The results showed the Windstar ride to be clearly superior, thanks in large part to a suspension system specially tuned to emphasize ride characteristics normally associated with luxury cars. A MacPherson strut suspension design, noted for its excellent ride, was chosen for the front. A new twist-beam configuration was selected for the rear. The suspension system incorporates uniquely tuned dampers that help take the annoying jolts out of potholes and bumps. Even the tires were developed and tuned specifically to optimize a ride that truly must be experienced to be appreciated.

acteristics normally associated with luxury cars. A MacPherson strut suspension design, noted for its excellent ride, was chosen for the front. A new twist-beam configuration was selected for the rear. The suspension system incorporates uniquely tuned dampers that help take the annoying jolts out of potholes and bumps. Even the tires were developed and tuned specifically to optimize a ride that truly must be experienced to be appreciated.

A FEELING OF SECURITY

The same care and attention that produced an excellent ride went into the development of the other half of the *ride and handling* equation. The wheels were moved outward, giving Windstar a wider base for secure maneuvering. The

All-season steel-belted radial-ply tires are designed for excellent traction in all kinds of weather. They were developed and tuned specifically for Windstar.



responsive handling imparts confidence, especially when taking curves, thanks to an optimized rate of understeer.

This capability is brought about through the use of precise rack-and-pinion steering, suspension componentry that's fine tuned for handling performance, and an integral rear stabilizer bar. Smooth-stopping power front disc/rear drum brakes with 4-wheel anti-lock system (see left) round out Windstar's handling hardware. It all adds up to a driving experience that's both satisfying and secure. And that's a valuable commodity indeed in the world of the minivan.

Windstar LX shown in Deep Emerald Green Clearcoat Metallic over Light Opal Clearcoat Metallic.

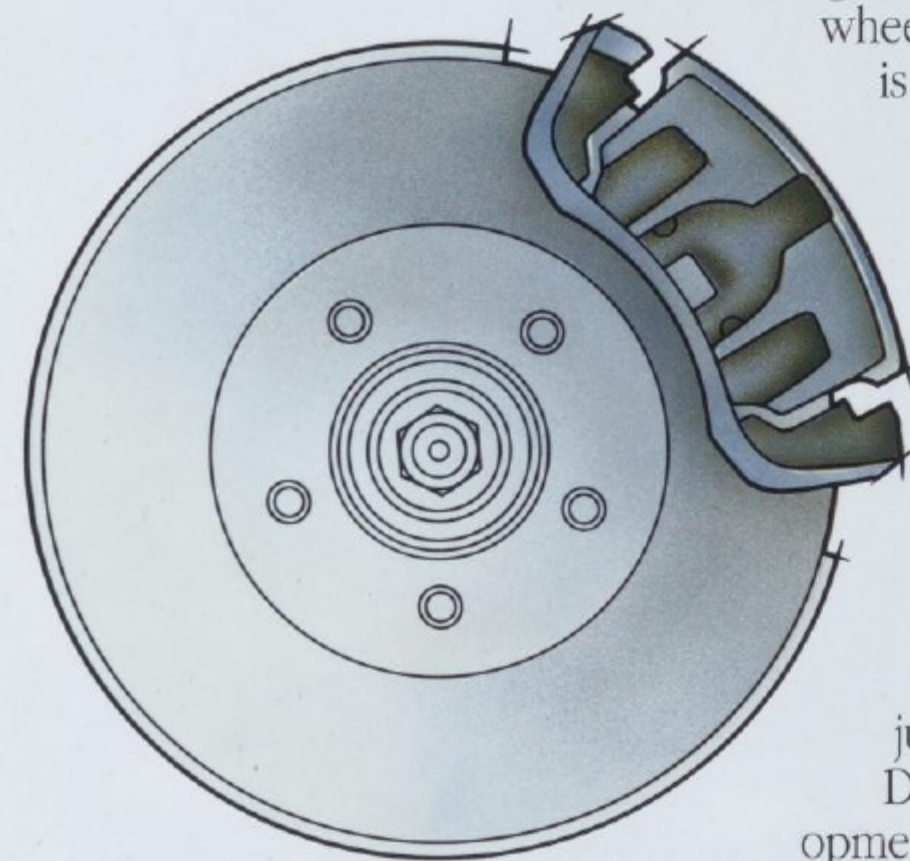

In addition to the traction benefits of front-wheel drive, Windstar has the straighter stopping capability and greater steering control of a standard 4-wheel anti-lock braking system (ABS). ABS prevents the wheels from locking up during braking under most conditions most of the time by applying and releasing the brakes up to 10 times per second. It's much like a professional driver who skillfully "pumps" the brakes, only a great deal faster.

The MacPherson strut front suspension includes a stabilizer bar to help maintain the proper attitude when cornering.

The 4-speed automatic transaxle is electronically controlled for efficiency (EPA mileage estimates unavailable).

Windstar's smooth ride is due in part to its twist-beam rear axle design and variable-rate rear coil springs.

Windstar's 3.8L V-6 engine puts out 155 hp at 4,000 rpm for smooth, confident power.

Windstar's steering system is the precise rack-and-pinion design with power assist.

Power front disc/rear drum brakes include a 4-wheel anti-lock system to help bring Windstar to a more controlled stop in many braking situations.

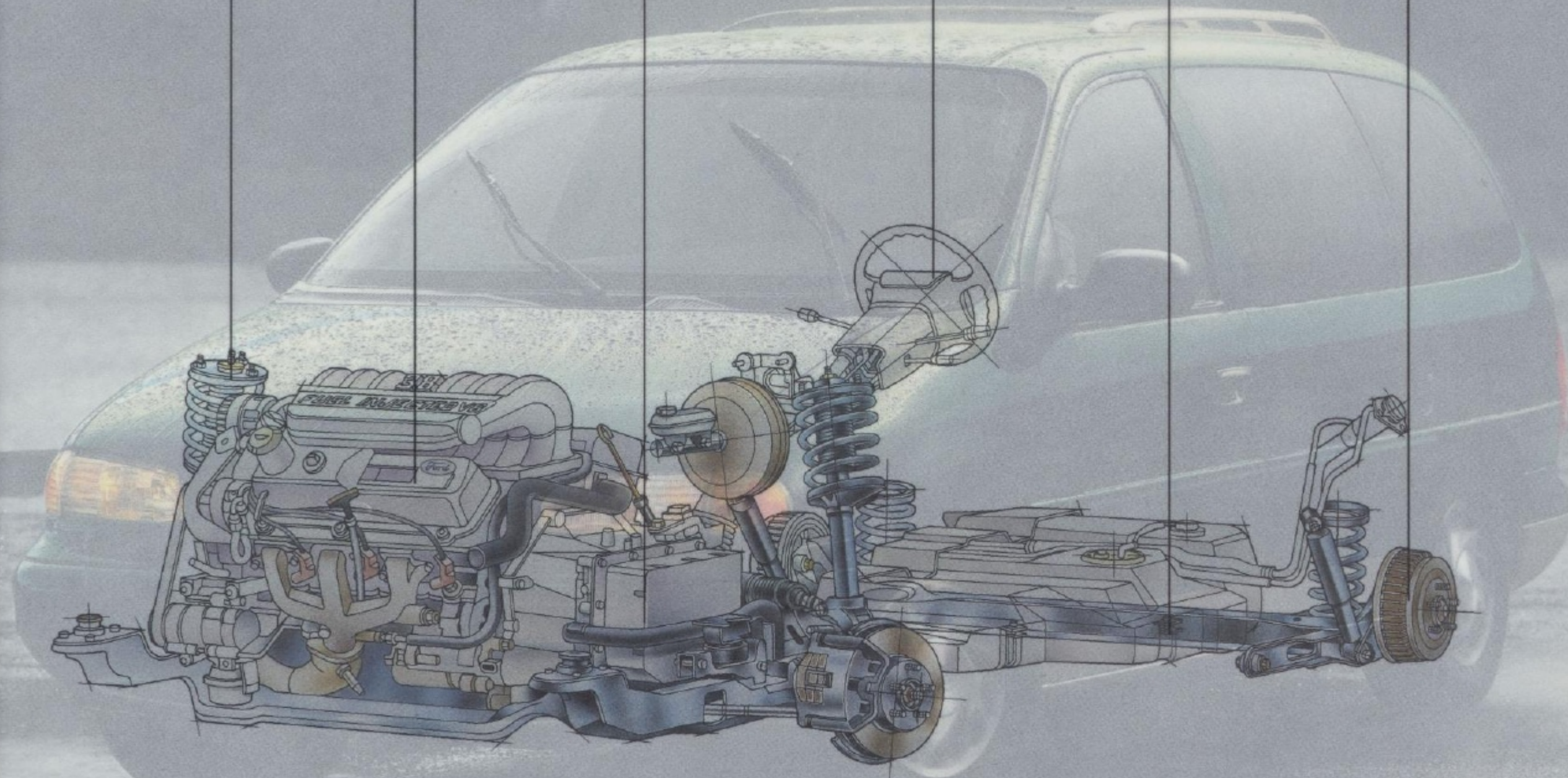

CAPABILITY & CAPACITY



Windstar's rear liftgate opens wide for access to the generous 144 cubic foot cargo area (with the rear bench seats removed). The latch is on the side of the liftgate so it doesn't interfere with the loading or unloading of cargo.

Don't be fooled by the sleek silhouette or by the car-like ride. The versatility and capacity are here. Windstar has more space inside than all the leading minivans — room for seven with lots of extra space for cargo.

GREAT FOR PEOPLE

Windstar's spacious 7-passenger seating arrangement provides excellent accommodations for just the two of you or the entire starting lineup of the junior hockey

team. Front bucket seats recline and can be adjusted fully 7" forward/back for individual comfort. There's also an optional track for the 3rd-row bench seat (standard in LX) to allow for leg room adjustment.

GREAT FOR CARGO

The same low step-in height that makes it easy to get in and out of the vehicle also makes it easy when it comes to

loading or unloading cargo. And the sliding side door is convenient in tight spaces.

The 2nd- and 3rd-row benches can be easily removed for a 144-cu.-ft. cargo area. Because they're made with magnesium stanchions, they're lighter than conventional seats.

But even without removing the seats, the backs can be folded forward for a flat load floor. You can actually carry large 4' x 8' panels without seat removal (with the liftgate kept open).

And the optional 3rd-row seat track allows for up to 23.8 cu. ft. of stowage behind the seat, enough for all kinds of luggage and other gear.

Windstar versatility allows a number of seating combinations depending on the nature of your people/cargo requirements.

Standard seating for seven includes reclining front buckets with inboard armrests, passenger-side seat back assist handle, 2-passenger bench with right-hand armrest, and 3-passenger rear bench. Quad captain's chairs are optional with LX (see your dealer for availability).

With Windstar, step-in height is comfortably low for easy entry and exit through the front doors or the sliding side door. The front seats provide convenient walk-through to the rear compartment.

Rear seat backs, when folded down, form a flat load floor. With the liftgate open, 4' x 8' sheets can be accommodated without removing rear seats.

Magnesium stanchions help make Windstar's rear seats lighter and easier to handle than conventional seats. Designed with a "quick release" feature, they're easily removed to take full advantage of the spacious 144-cubic-foot cargo area.



The optional track for the 3rd-row bench seat allows travel adjustment for comfort or even more stowage space (standard with LX).

SAFETY & SECURITY



(a)

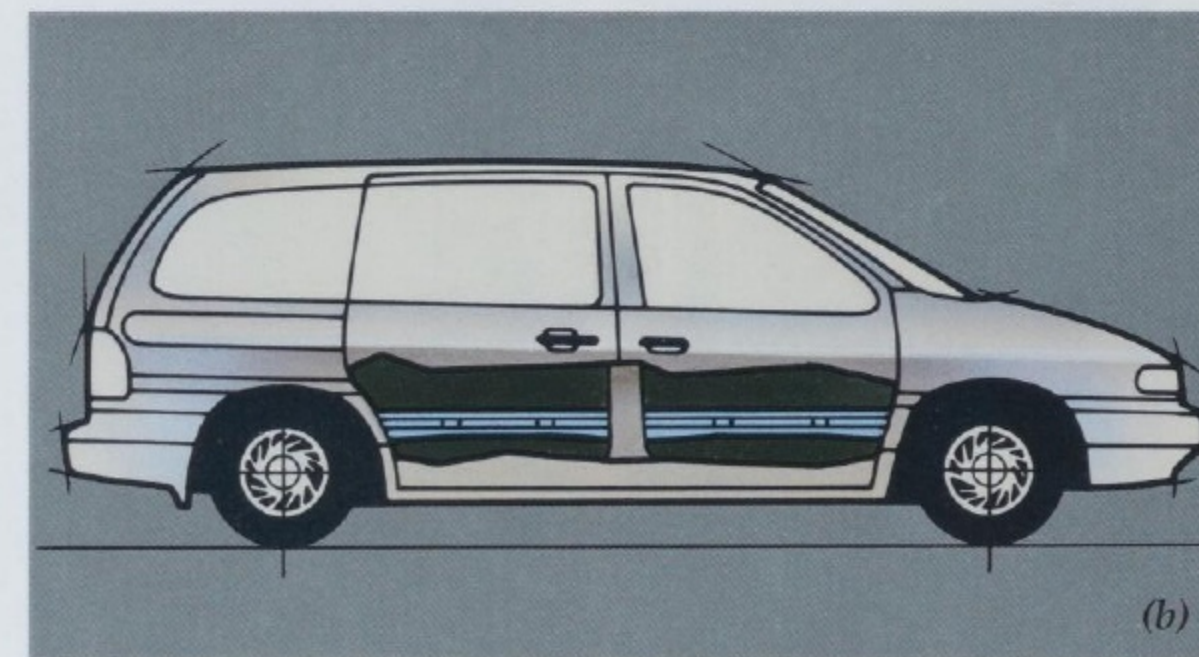

(b)



(c)

When it comes to your vehicle, there's nothing more important than the well being of your family and friends, and we're *committed* to safety. As a result, Windstar has more standard safety features than any other minivan.

Windstar meets federal passenger car safety standards (except models equipped with Privacy™ glass), which are more stringent than the truck standards applied to some other minivans. But more importantly, Windstar meets *Ford* standards, which in some cases *exceed* federal guidelines. Crash tests, for example, are conducted at 35 mph, not at the 30-mph federal standard. And Windstar has undergone tests that aren't mandated by the gov-

ernment. Ford fuel system integrity tests and rear corner roof crush tests are cases in point. There are many other instances where Ford takes that extra step to help protect passengers. Safety just can't be effectively addressed with minimum standards.

EXCLUSIVE MEASURES

Standard dual air bags. Standard 4-wheel anti-lock brakes. Standard 5-mph bumpers. Windstar is the *only* minivan with *all three*.

PROTECTIVE MEASURES

Windstar safety equipment that helps protect you and your passengers in the event of an accident includes an air bag to supplement the safety belts for both the driver and

front passenger. The system provides added protection from head and chest injuries in certain moderate to severe frontal impacts (remember to always wear safety belts). 3-point safety belts for outboard occupants, side intrusion door beams, a front crush zone design, knee bolsters and an energy-absorbing steering column are others.

PREVENTATIVE MEASURES

Windstar also incorporates features which can help you avoid an accident in the first place. These include such items as standard 4-wheel anti-lock brakes (see page 12), a childproof lock for the sliding side door, a brake/shift interlock and available heated outside mirrors.

(a) Windstar's front end was designed with a "crush zone" to help absorb energy in the event of a frontal impact. Front and rear 5-mph bumpers help protect vehicle components from damage.

(b) Among the many occupant safety features in all Windstars are side door intrusion beams.

(c) The rear sliding side door features a childproof lock which, when activated, won't allow the door to be opened from inside the vehicle.

Right: Standard equipment includes an air bag to supplement the safety belts for the driver as well as the front passenger.

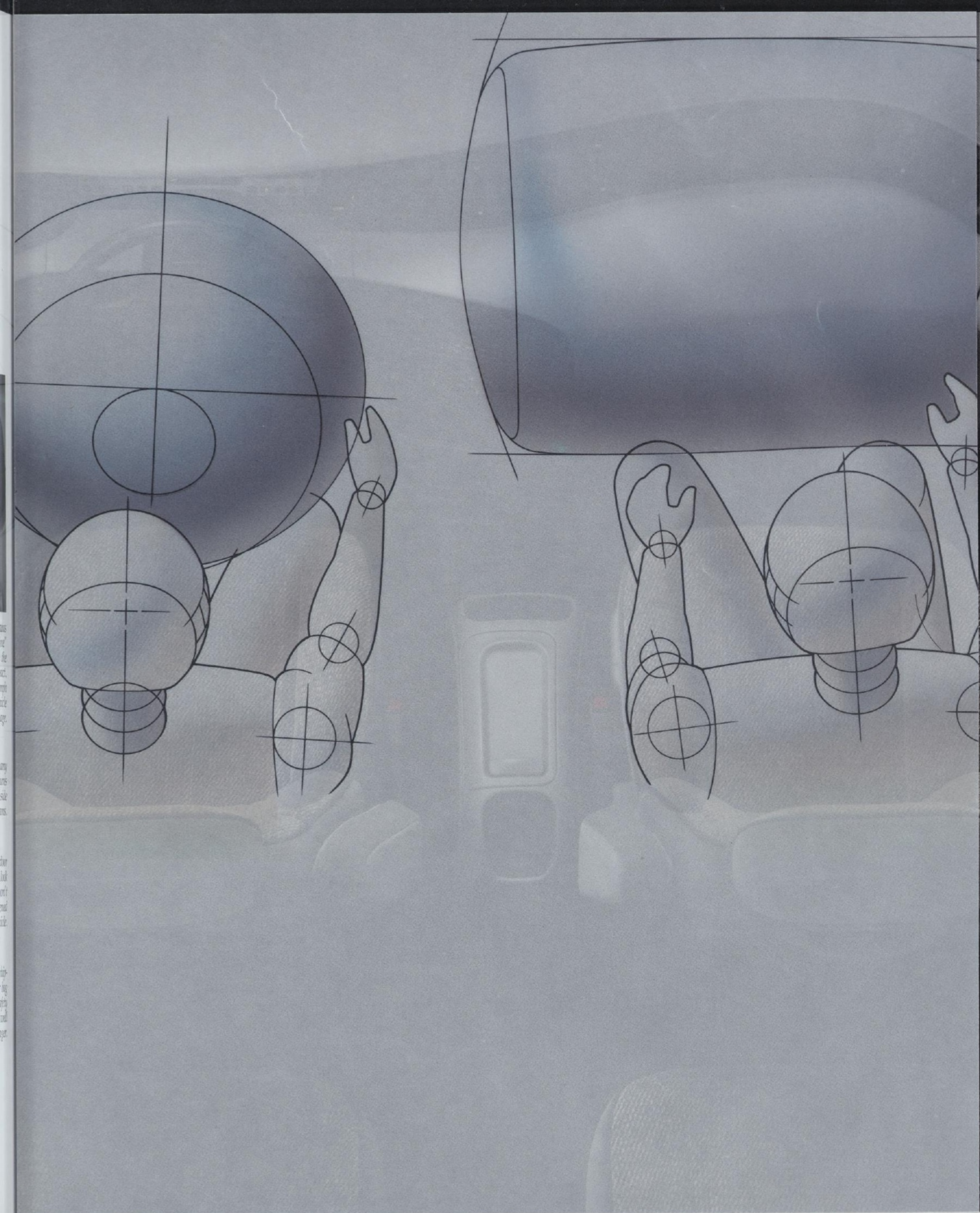

QUIET & COMFORT

The Windstar policy on sound can be quickly summarized. Desirable sounds, such as voices or music, are encouraged. Unwanted sounds, such as road noise, are strenuously discouraged. To help determine the right design and the right materials for the job, substantial testing was required.

Much of this testing occurred in the *quiet room*, pictured at right. Replete with acoustical baffles that make your voice seem to carry just past the end of your nose and stop, this eerie environment is the best place to evaluate sounds, both wanted and unwanted. To accurately establish acceptable conversation levels, a robotic head that "hears" in the same way a human does was employed. Sounds "heard" by the robot were recorded, graphed and analyzed.

As a result of these evalua-

tions, noise-deadening measures like one-piece floor/dash construction, an isolated engine subframe, and supplemental insulation were adopted. Wind noise is reduced by limo-type doors, flush glass, and a sliding door with secondary seals and a concealed track.

These and many other design elements produce an interior that's optimized for ease of conversation. In fact, Windstar is quieter than all leading minivans when traveling at steady speeds, allowing third-seat passengers to converse with front-seat occupants at normal voice levels, something not so easily done in some other minivans.

A quiet environment is simply more comfortable for all. And for the driver, whose performance depends on the ability to stay alert and concentrate, it's especially important.

The Windstar interior was designed around ease of conversation. Ford's "quiet room" was one of the tools used for extensive acoustical evaluation and testing that helped make Windstar so remarkably quiet when traveling at steady speeds.



FEATURES & FUNCTION



Have you ever been riding in an automobile and noticed some feature that impressed you as being particularly useful or attractive? "Nice touch," you probably said to yourself.

Sometimes it's the "little" things, a well-placed control or a well-designed storage space, that can make a big difference in the enjoyment of the trip.

Windstar was designed with a lot of thought given to those who would be occupying it — you and your passengers.

Much care, for example, went into the development of the new one-piece, flow-through instrument panel that "wraps around" the front occupants and integrates smoothly with the door trim. Most controls and gauges are backlit for nighttime visibility, and all are positioned for easy identification and convenient reach.

Radio controls are provided for second-seat passengers. In addition to map pocket storage in the front doors (and on the backs of the front seats with LX), there are storage bins located throughout the vehicle as well as a spacious, lockable glove box. Handy cup holders are strategically positioned around the vehicle (rear holders even provide space for juice boxes, shown at left).

These and other such features are designed to enhance the overall pleasure of the Windstar driving experience.



Top: Ford added security, the keyless entry system (right) and the remote keyless entry system (with two controllers) are available as options.

Center: The second-row passenger-side seat back tilts conveniently forward with optional captain's chairs (see your dealer for availability).

Bottom: The optional high-capacity air conditioner and auxiliary heater features efficient side and overhead ducts.

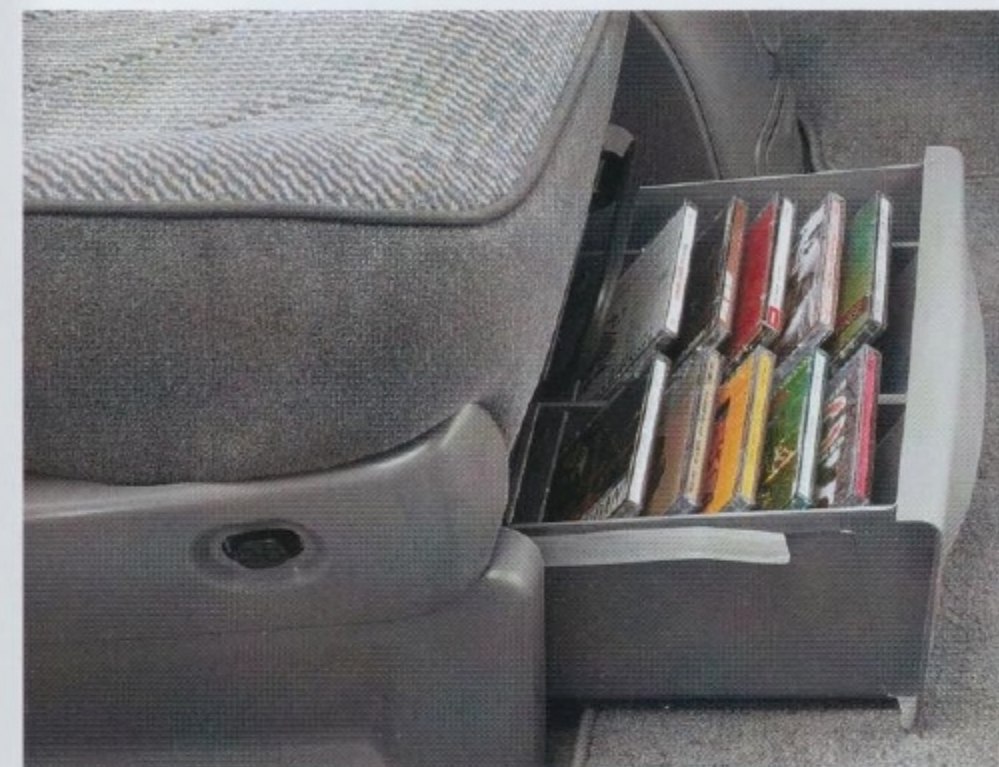

Top: Windstar LX includes a handy storage drawer under the front passenger seat.

Center: A convenient sliding door step lamp lights your way in and out of the vehicle at night.

Bottom: Speed control and a tilt steering wheel are available with GL and LX. A "Tap up/tap down" feature allows speed changes in 1 mph increments.



Top: Enjoy the remarkable sound reproduction of digital technology with the optional compact disc player.

Center: Windstar's "power point" in the optional floor console allows the use of a cellular phone (available from your dealer), electric shaver or other small appliance.

Bottom: Windstar LX features a cargo net that helps keep loose items from shifting around.

POWERTRAIN & DIMENSIONS

Windstar's standard engine is a V-6 displacing 3.8 liters. For smooth, confident passing power, it achieves 155 horsepower at 4,000 rpm (SAE net) and produces 220 foot-pounds of torque at 3,000 rpm.

With this impressive power, however, also comes impressively efficient operation (EPA mileage estimates were not available at time of printing). The sequential electronic fuel injection system provides pre-

cise fuel metering and it, like all engine functions, is governed by EEC-V, the latest-generation Ford computer control module. Tested and proven in high-performance racing cars, EEC-V brings the latest in electronically supervised performance to the family vacation trip and the daily commute.

Also standard is an electronically controlled 4-speed automatic transaxle. The shift lever is conveniently located on the

steering column and includes an overdrive "cancel" switch for situations when the greater torque power of the lower gears is preferred.

DESIGNED WITH DRIVER CONVENIENCE IN MIND

Windstar's powertrain was developed with an eye for the details that help make life a little easier for the driver. Underhood service points are a good example. All are highlighted for easy identification and are situated within a comfortable reach. If you've inadvertently left the interior lights on, a "battery saver" feature turns them off 40 minutes after the ignition key is turned off and the door is closed. And Windstar's fuel tank holds a generous 20 gallons (25 standard with LX and optional with GL). This means a comfortable driving range with fewer stops for fuel (see your dealer for EPA gas mileage estimates).

Windstar benefits from the latest generation of Ford's electronic engine control module, EEC-V. Tested on sophisticated Formula 1 and Indy racing cars, EEC-V improves Windstar's performance, driveability, fuel economy and emissions control. It incorporates more than a dozen integrated circuits and uses 80,000 transistors. And with 66% more memory than the EEC-IV system it replaces, EEC-V can perform up to 20% faster for enhanced systems control.

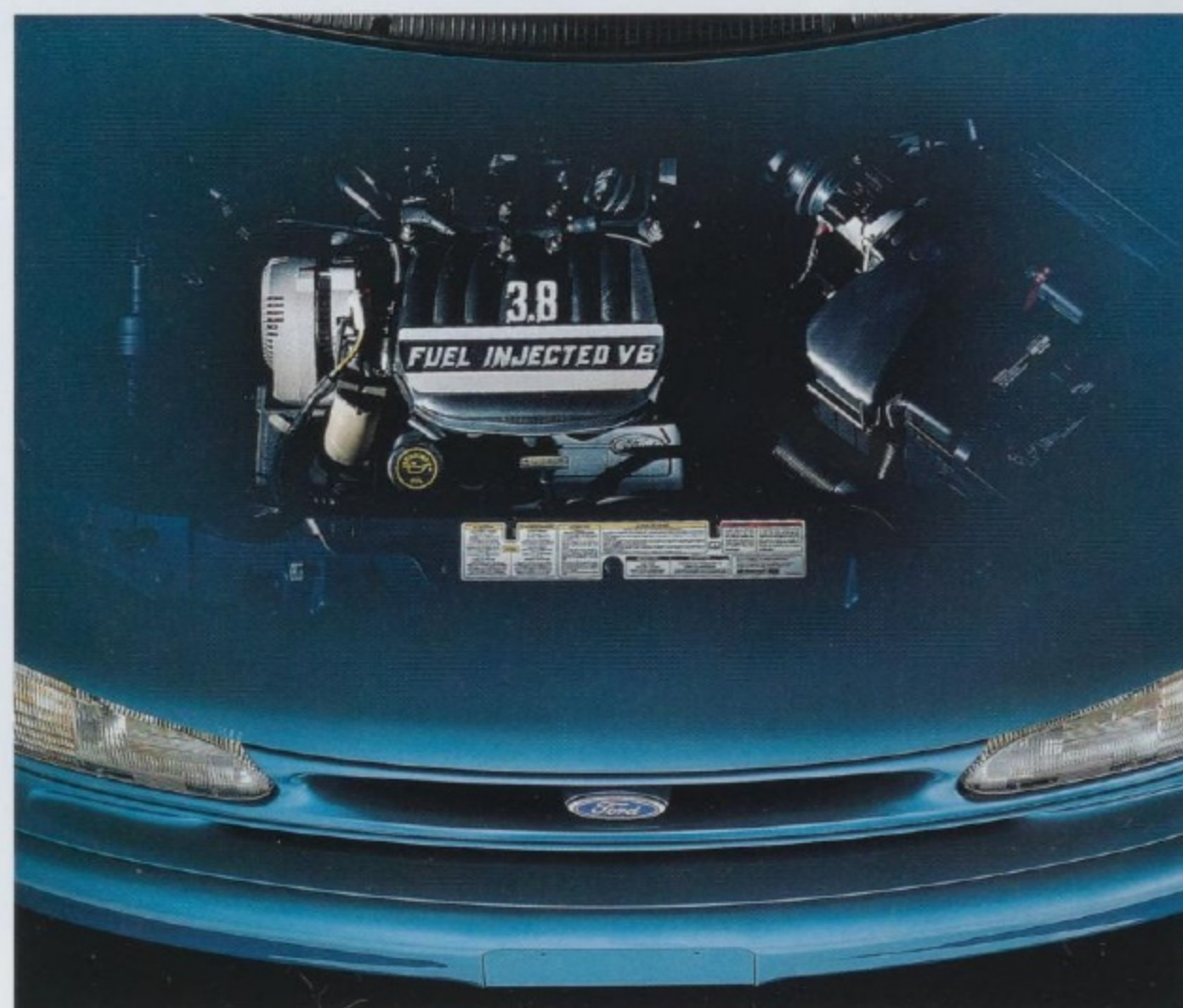

DIMENSIONS

Wheelbase	120.7"
Overall length	201.2"
Overall width	74.3"
Overall height	68.0"
Front tread	64.3"
Rear tread	63.0"
Front compartment	
Head room	39.3"
Leg room	41.8"
Rear compartment	
2nd row head room	38.9"
2nd row leg room	39.2"
3rd row head room	38.1"
3rd row leg room	35.3"
Maximum cargo volume (cu. ft.)	144*
Maximum seating capacity	7

*With rear seats removed.

SPECIFICATIONS

Drivetrain:	Front-wheel drive
Engine type:	3.8 liter V-6
Induction system:	Sequential electronic fuel injection with EEC-V computer
Compression ratio:	9.0:1
Transaxle:	Electronic 4-speed automatic overdrive
Horsepower, SAE net:	155 @ 4000 rpm
Torque, SAE net:	220 lbs.-ft. @ 3000 rpm
Battery:	72 AH maintenance-free
Alternator:	130 amps
Frame:	Fully integrated welded steel
Front suspension:	MacPherson struts with stabilizer bar
Rear suspension:	Twist-beam rear axle with variable-rate coil springs and gas-pressurized shock absorbers
Steering:	Rack-and-pinion, power assisted
Brakes:	Power front discs/rear drums with 4-wheel anti-lock system
Fuel tank:	20 gallons (25 gallons standard with LX; optional with GL)
Wheels (type/size):	Steel 15" x 5.5" (GL); cast aluminum 15" x 6" (LX)
Tires:	P205/70FR15SL BSW all-season (GL) P215/70FR15SL BSW all-season (LX)

FEATURES, PREFERRED EQUIPMENT PACKAGES, OPTIONS AND COLORS

NOTE: Some items designated by a dash may be included in one or more Preferred Equipment Packages. See listing this page.

EXTERIOR FEATURES

	GL	LX
Limo-style front doors and right-hand sliding side doors with concealed drip rail system	S	S
Dual sail-mounted mirrors, right-hand convex	S	S
Luggage rack	O ⁽¹⁾	●
Stone abrasion protection on rocker panels	S	S
Solar tinted glass all around	S	S
Privacy™ glass	O ⁽²⁾	●
Flip-open rear quarter windows	S	S

COMFORT AND CONVENIENCE

Air conditioning	●	S
High capacity air conditioner and auxiliary heater	O ⁽²⁾	●
Locking glove box	S	S
Light Group: Includes front map/dome lamp, glove box lamp, left-hand siderail lamp, two under-instrument-panel lamps and under-hood lamp	O ⁽³⁾	S
Electronic instrument cluster package: includes electronic cluster, automatic headlamps, and auto-dimming rearview mirror	-	O ⁽⁴⁾
Floor console	O ⁽¹⁾	O
Illuminated entry system	-	S
Day/night rearview mirror	S	S
Front and rear cup holders	S	S
Floor mats	O	●
Cargo net	-	S
Leather-wrapped tilt steering wheel	-	S
Dual overhead visor mirrors	S	-
Dual illuminated visor mirrors and auxiliary sun shields	-	S

SEATING

7-passenger seating	S	S
Dual high-back front buckets with integral headrests, full 7" fore/aft adjustment and adjustable recliners	S	-
Dual low-back front buckets with adjustable headrests, 6-way power driver's seat and power lumbar support for driver and passenger	-	S
2- and 3-passenger cloth rear benches with forward-folding seat back and quick release for easy removal	S	S
3rd-row 7" seat track	●	S
2nd-row dual captain's chairs and 3rd-row bench seat (see your dealer for availability)	-	O
Front seat back map pockets	-	S
Front passenger under-seat storage area	-	S

SOUND SYSTEMS

Electronic AM/FM stereo radio with 4 premium speakers	S	-
2nd-row sound controls and mini headphone jacks	S	S
Electronic AM/FM stereo radio with cassette	O ⁽⁵⁾	S
Ford JBL Audio System	-	O ⁽⁶⁾
Premium AM/FM stereo radio with CD player	O ⁽²⁾	●
Compact disc changer, 10 disc capacity (dealer-installed option)	-	O

FUNCTIONAL FEATURES

	GL	LX
Sound insulation package	S	S
Child-proof lock on sliding side door	S	S
Power Convenience Group: power locks, power mirrors and power windows (includes rear quarter flip-out glass)	-	S
Keyless entry system: Includes keyless entry, anti-theft system, autolock/relock and heated mirrors	-	O
Remote-control entry	O ⁽²⁾	O ⁽⁴⁾
Fingertip speed control/tilt steering wheel	O ⁽⁷⁾	●
Interval windshield wipers with dual washer jets	S	S
Rear window wiper	S	S
Electric rear window defroster	O ⁽³⁾	●
20-gallon fuel tank	S	-
25-gallon fuel tank	O ⁽²⁾	S
5-mph impact bumpers front and rear	S	S
Air bag Supplemental Restraint System for driver and front passenger	S	S
Front (passive with adjustable "D" ring) and rear 3-point lap/shoulder belts for outboard passengers, lap belt for center rear position	S	S

WHEELS AND TIRES

P205/75R15 BSW all-season radial tires	S	-
P215/75R15 BSW all-season radial tires	O ⁽¹⁾	S
Full wheel covers	S	-
Bright cast aluminum wheels	O ⁽¹⁾	S

PREFERRED EQUIPMENT PACKAGES

	GL			LX	
	470A	471A	472A	476A	477A
7-passenger high-back bucket seats with adjustable seat track and folding seat back load floor for the 3rd-row bench	●	●	●		
Air conditioning	●	●	●	S	S
Light Group	O	●	●	S	S
Power Convenience Group: power windows, power locks and power mirrors		●	●	S	S
Electric rear window defroster	O	●	●	●	●
Electronic AM/FM stereo radio with cassette	O	O	●	S	S
Fingertip speed control/tilt steering wheel	O	●	●	●	●
Floor mats	O	O	O	●	●
Luggage rack			O	●	●
Two-tone paint				●	●
Electronic instrument cluster package: includes electronic cluster, automatic headlamps, and auto dimming rearview mirror				O	●
Privacy™ glass	O	O	O	●	●
Remote-control entry	O	O	O	●	●
Premium AM/FM stereo radio with cassette				●	●

S = Standard O = Optional ● = Preferred Equipment Package item

⁽¹⁾Option restricted to Preferred Equipment Package 472A.

⁽²⁾Option restricted to Preferred Equipment Packages 471A and 472A.

⁽³⁾Option restricted to Preferred Equipment Package 470A.

⁽⁴⁾Option restricted to Preferred Equipment Package 476A.

⁽⁵⁾Option restricted to Preferred Equipment Packages 470A and 471A.

⁽⁶⁾Option restricted to Preferred Equipment Package 477A.

⁽⁷⁾Option restricted to Preferred Equipment Package 471A.



Light Evergreen Frost Clearcoat Metallic
OG, M



Plum Mist Clearcoat Metallic
OG, M



Indigo Blue Clearcoat Metallic
RB, OG



Royal Blue Clearcoat Metallic
RB, OG, M



Deep Emerald Green Clearcoat Metallic
OG, M



Teal Clearcoat Metallic
OG, M



Crimson Clearcoat
OG, M



Light Opal Clearcoat Metallic
RB, OG



Vibrant White Clearcoat
RB, OG, M



Tucson Bronze Clearcoat Metallic**
M



Champagne Clearcoat Metallic*
RB, M



Chameleon Clearcoat Metallic*
(see your dealer for availability)
OG, M

Interior trim colors: RB = Royal Blue OG = Opal Grey M = Mocha

NOTE: See your dealer for LX two-tone combinations. *Not available on GL. **Not available on LX.

BUMPER-TO-BUMPER COVERAGE

The 36-month/36,000-mile bumper-to-bumper coverage of Ford's new vehicle limited warranty covers the complete vehicle (except tires, battery, service adjustments and other items covered under separate provisions) against defects in factory-supplied materials or workmanship. For complete information, see your dealer.



Optional Ford Extended Service

Plans can cover major components on new Ford cars and light trucks for longer than the vehicle's basic warranty. Your dealer has full details.

FORD CITIBANK CREDIT CARD

Using your Ford Citibank Visa® or MasterCard® could earn you

hundreds, even thousands of dollars from Ford toward the purchase or lease of a new Ford, Lincoln or Mercury product. To apply or get more information, call 1-800-374-7777. Or visit a Ford or Lincoln-Mercury Dealer, or a branch office of Citibank.

ASSURANCE THAT TRAVELS WITH YOU

Every new Ford includes the assurance of an emergency Roadside Assistance Program provided by Ford Auto Club, Inc. during the 3-year/36,000-mile bumper-to-bumper warranty period. Help is a toll-free phone call away 24 hours a day, anywhere in the continental United States should you need any towing assistance, fuel delivery, tire change, a jump start or even help when you're locked out of your car. Ask your

Ford Dealer for complete details on the Ford Roadside Assistance Program and a copy of this limited warranty.



Ford Credit is a full service company that makes a wide variety of financing and leasing programs available to qualified buyers through the Ford Dealer of your choice. Through Ford Credit's financing or Red Carpet leasing, arrangements suited to your special needs can be made quickly and conveniently right at the dealership. Ask your Ford Dealer for the facts on any of Ford Credit's financing or lease plans.

DEALER-INSTALLED ACCESSORIES

Ford brand accessories, available at your Ford Dealer, meet or exceed our strict engineering specifications.

They're custom designed and manufactured to complement the style and quality of your Ford-built vehicle.

PRODUCT CHANGES

Following publication of this catalog, certain changes in standard equipment, options, prices and the like, or product delays, may have occurred that would not be included. Your Ford Dealer is your best source for up-to-date information. Ford Division reserves the right to change product specifications at any time without incurring obligations.

OPTIONS AVAILABILITY

Options shown or described are available at extra cost and may be offered only in combination with other options or subject to additional ordering requirements or limitations.



Printed on recycled paper
10% post-consumer waste

992-Ann. Litho in U.S.A. 1/94

