

**f-series**  
ninety-nine





It's a story that's been told for over fifty years. A story that begins every day before dawn and continues long into the night. It's heard in mills and factories, on job sites, in barns and **out along the fence line.** It's a story that's passed down from generation to generation about callused hands and strong backs ... about friendship and laughter. It's a story that's now being told by two tough trucks and, as far as anyone can tell, it's a story that never ends.





F-150 XLT SuperCab 4-door 4x4 in Black Clearcoat  
Super Duty F-350 XLT SuperCab 4-door 4x4 in Red Clearcoat

## F-Series Pickups



F-150 XLT Flareside in Black Clearcoat with the available 4x4 XLT Sport Group (available Fall, 1998).

For **50 years**, Ford F-Series has been meeting the needs of demanding truck people all over the country, and with the **only complete line of standard 4-doors** in the industry, it's poised to meet even more. F-Series has had a philosophy of **continuous refinement**, constantly reaffirming its leadership in a competitive industry. It's been **America's #1 selling pickup brand for 21 years** in a row and it also has more repeat buyers than any other.\*



The new look up front for the F-150/250 is one that means business.



SuperCab models now provide the convenience of four doors as standard. Both rear doors have an inside handle to make exiting from the back easier.



The available factory-installed "snapless" 150/250 tonneau cover (offered under 8,500 pounds GVWR) provides fast, easy installation and removal, great looks, and improved fuel economy.

\*Based on 1997 Ford New Vehicle Customer Survey.



F-150 XL Regular Cab 4x2 in Harvest Gold Clearcoat Metallic.

## F-150/250



F-250 XLT SuperCab 4x4 in Dark Toreador Red Clearcoat Metallic.

F-Series has the **most complete line of trucks** with over fifty different models available to custom fit the job. That's **more choices than anyone else** in the marketplace. It's truly America's worker of choice, with the largest pickup box by volume of any full-size truck. F-Series is also the **best-built** full-size truck.\* And the durable 5.4L engine features even **more Triton™ V8 power** for 1999. Nothing gets the job done like Ford F-Series pickups.



This electro-hydraulic control unit is part of the 4-wheel anti-lock braking system which is included with the XLT and Lariat models (optional on other models). ABS helps provide steering control while braking under most conditions, even on wet or slippery surfaces.

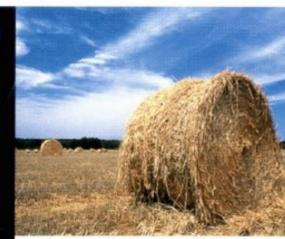

F-Series is big on towing. An F-250 Regular Cab 4x2 with the 5.4L Triton V8 can tow up to 8,700 pounds when properly outfitted, and its available rear load-leveling suspension keeps the vehicle at a consistent level if weight is added, removed, or shifts.

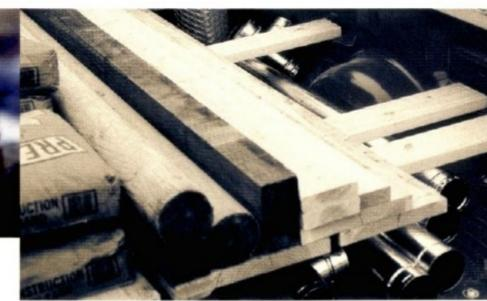

Go ahead, pile it on. F-Series is built to take it. Horizontal pockets and vertical slots allow for special setups, including two-tier loading.

\*Based on an average of consumer-reported problems at 3-months ownership in a survey of Ford and competitive models.

## Chassis

**All-season tread.**  
P235/70R16SL black-sidewall, all-season tires are standard on F-150 and designed for a variety of weather conditions. P255 and LT245 tires are also available in all-season and all-terrain tread designs.

**Getting started.**  
The standard 58 amp-hr. (540 CCA) and available 72 amp-hr. (650 CCA) batteries are maintenance free and include a convenient battery saver feature.

**Handling assistance.**  
A front anti-sway bar is standard with every F-150 and F-250 F-Series to enhance stability.

**Rugged suspension.**  
The twin-forged independent short/long arm (SLA) front suspension features forged upper and stamped-steel lower control arms. 4x4s include cast-iron lower control arms for extra strength and solid-steel adjustable-height torsion bars that contribute to off-road stability.

**Ladder-type frame.**  
The tough ladder-type frame (heavy duty with F-250) includes a fully boxed front section for strength. A special wax coating helps inhibit corrosion.

**Anti-lock braking.**  
Power brakes with rear anti-lock are standard. 4-wheel anti-lock brakes are optional (included with XLT and Lariat). Both systems provide straighter stopping capability, and 4-wheel ABS provides greater steering control while braking under most conditions, even on wet or slippery surfaces.

**Precise steering.**  
The power-assisted, recirculating-ball steering system provides precision along with a stable "on center" cruising feel.

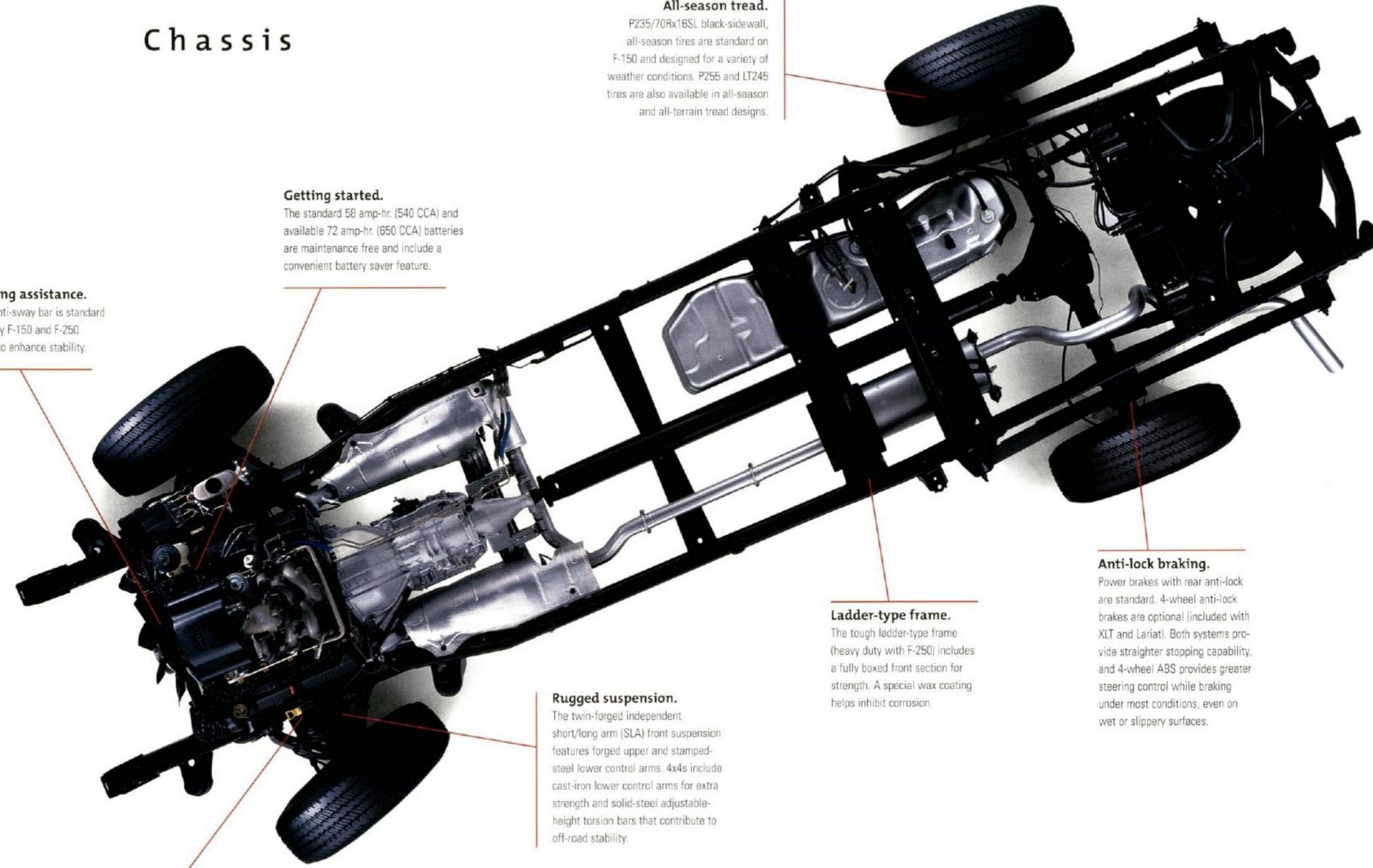

## Built Ford Tough

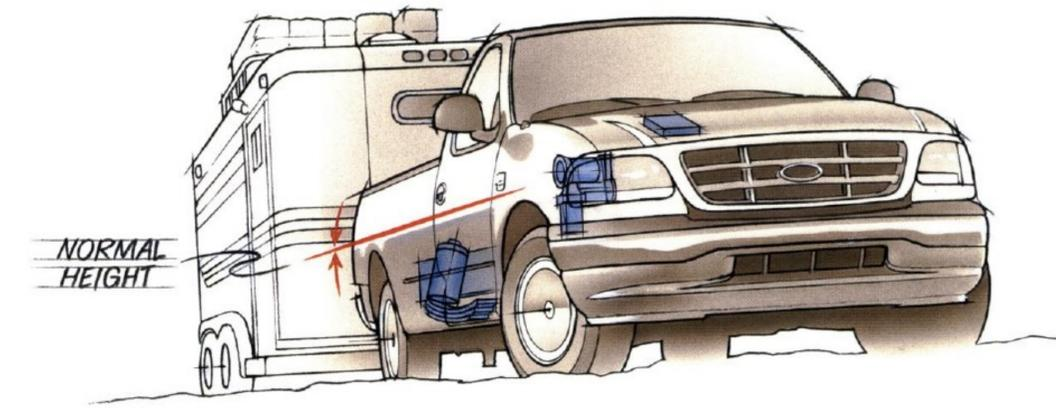

The available F-250 rear load-leveling suspension (XLT and Lariat) keeps the vehicle's passenger or cargo load consistently level.

F-Series is built to handle the big jobs. The rugged, proven ladder-type frame, which incorporates a front box section for strength, features a special wax coating for corrosion protection. The short/long arm (SLA) independent front suspension has forged upper control arms for strength as well as an anti-sway bar for stability. Front brakes have dual piston calipers found on larger 3/4- and 1-ton pickups. The F-250 has larger brakes, higher-capacity wheels and a heavy-duty frame.



The F-150/250 independent short/long arm (SLA) front suspension is designed to keep the ride comfortable.



The optional Class III Trailer Towing Group, which includes a frame-mounted hitch receiver, prepares the vehicle to tow larger trailers.



F-Series is big on cargo. With the optional payload package, the F-250 Regular Cab 4x2 can handle a hefty 3,295 pounds.



The XLT SuperCab cloth interior in Medium Graphite.

## Interior



The Lariat with optional leather-trimmed captain's chairs/console in Medium Prairie Tan.

There's no law that says "Built Ford Tough" can't be comfortable, roomy and spacious. F-Series is more of these than you might expect. The interior is new for 1999.

Front seats are wider and incorporate foam which creates new contours for more comfort and support. In the Lariat series, the 40/60 split bench seat is leather-trimmed. You may also choose leather-trimmed captain's chairs with Lariat or opt for cloth captain's chairs with the XLT series.



Climate and audio system controls are located in an easy-to-reach center pod.

A Premium single CD radio with Premium Sound is standard with Lariat, available with XL and XLT. A 6-disc CD changer with Premium AM/FM cassette with Premium Sound is available with most XLT and Lariat models.



XLT and Lariat seats feature standard driver lumbar support and reclining seat backs.



The front split bench seat in XLT and Lariat features a padded, fold-down center armrest with cupholder. Under the armrest there's a large storage compartment. This seat is optional with the XL series.



The F-Series instrument panel is designed for functionality as well as style. Large buttons and knobs are easy to operate, even with gloves on. A passenger-side deactivation switch for the Second Generation Depowered airbags is standard. Always wear your safety belt and deactivate passenger airbag when using a rear-facing child safety seat.

## more Triton power



The 5.4L Triton V8 is available with bi-fuel capability – natural gas or propane – in addition to regular unleaded.

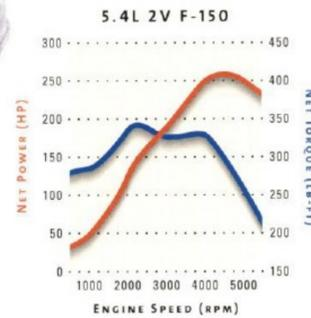

Triton is the first and only line of full-size pickup engines to provide a fail-safe cooling system to help protect the engine from damage due to coolant loss.



Each Triton engine can go 100,000 miles without a first-scheduled tune-up under normal driving conditions with routine fluid and filter changes.

Sometimes the job calls for more than merely loading up the pickup box. It calls for **pulling or pushing power.**

That's the time for the **power-improved** 5.4L Triton V8.

**Power and torque have been increased**

for 1999. Peak horsepower is up 25 to 260 at 4,500 rpm. Peak torque is up 15 to 345 lbs.-ft., while the engine speed at which it's achieved is actually lower. A properly equipped Regular Cab F-250

4x2 with Triton V8 power tows trailers up to 8,700 pounds. It's **pulling power no competitor can match.**

As for pushing, F-150 and F-250 4x4 Regular Cab models with

Triton V8 power and available Snow Plow Prep Group can really

move it out. Triton engines are designed to be **true work engines with great performance, ready to**

take whatever you dish out.

## Triton™ power

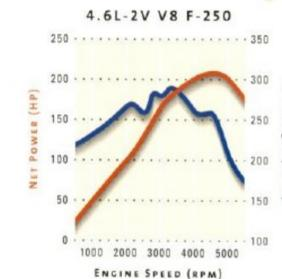

The F-150 and F-250 powered by the 4.6L Triton V8 have the highest maximum V8 payload rating in their class when properly equipped (below 8,500 lbs. GVWR).

There's more available **power** for 1999. F-Series

Triton engines, the only OHC engines in a full-size pickup, put

their power and torque where you use it. Truckers know that for

hard work or play, the aim is **low-end torque.** Triton

engines deliver 90% of their torque at or below 2,000 rpm. And

**they're durable.** Each powerplant includes a high-flow

water pump, large-capacity oil pan, platinum-tipped spark plugs

and a **maintenance-free cam drive chain.**

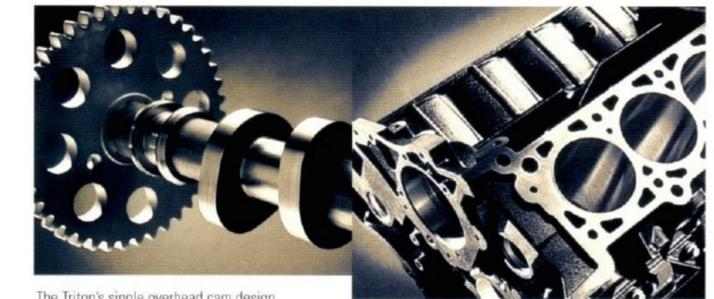

The Triton's single overhead cam design (SOHC), with a maintenance-free silent chain drive, eliminates the need for push rods. This helps reduce friction and contributes to fuel efficiency. (EPA estimates unavailable at press time. See your dealer for current information.)

The Triton deep-skirt block with cross-bolted main bearing caps provides structural rigidity and smooth operation.



## power & durability

Today, trucks are becoming more popular than ever before and are enjoyed by people from all walks of life. And while style and comfort are important, power and durability remain the true essence of these vehicles. Like all Ford trucks, F-Series pickups have been designed to provide years of tough, capable, dependable service to their owners.

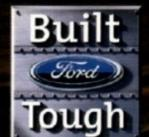



Don's grandfather bought the '57 F-Series pickup

new. His dad inherited it in '79. **Now it**

**was Don's turn.** True, the odometer

was on its second trip around, but it ran great. And it

had been running great for years to countless

job sites and endless hunting trips, not to mention

every family reunion. According to grandpa,

she has one funny quirk, though. She doesn't like

to sit. Which seems appropriate enough to Don.

Because neither do dad or grandpa.





Super Duty F-250 Lariat Regular Cab 4x2 In Silver Clearcoat Metallic.

## Super Duty F-250 and F-350



Super Duty F-250 XLT Regular Cab 4x2 in Silver Clearcoat Metallic.

Right across the entire lineup, Super Duty F-Series trucks have **best-in-class cab roominess**. They also offer the largest diesel with best-in-class torque. You can choose from a remarkable **44 configurations**, 17 of which can be found nowhere else in the marketplace. It all begins with the Super Duty F-250, the **logical first step** into the over-8,500-pound-GVWR world. The Super Duty F-350, with its 24 configurations, includes **six that are unique**. GVWR range is 9,900-12,500 pounds.



A class-exclusive lower window beltline near the outside mirror improves visibility on the road.



The styling of the Super Duty F-Series suggests rugged and robust, and that's exactly what it is. The bold front end can stare down the toughest challenges.



The Super Duty F-Series tailgate is easily removable to accommodate long cargo. With XLT and Lariat, it's also lockable.



Super Duty F-550 XLT Crew Cab 4x4 in Bright Red Clearcoat

## Super Duty F-450 and F-550



Super Duty F-450 XL Crew Cab Chassis Cab 4x2 in Oxford White Clearcoat

The brawny, dual-rear-wheel Super Duty F-450 and F-550 series are designed for **easy upfitting** and provide the muscle and versatility to take on the biggest and toughest applications. Super Duty F-450 Chassis Cabs have a GVWR of 15,000 pounds. The **highest standard GVWR in its class**, a big 17,500-pound capability, belongs to the rugged Super Duty F-550 Chassis Cabs, with **19,000 pounds available** (Regular Cab 4x2 configuration when properly equipped).



The through-rail fuel filler neck, standard with Super Duty Chassis Cab models, makes upfitting easier.

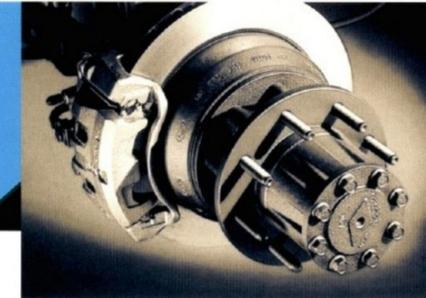

Super Duty F-450 and F-550 brake rotors are larger in diameter, which provides effective braking for higher payloads. Rear brakes shown.



Available trailer tow mirrors with specially designed optics are extended out from the body to provide a better view.

# Super Duty Chassis

**Anti-lock brakes.**  
Power four-wheel disc brakes are standard with all series. Four-wheel anti-lock brakes are standard over 10,000 lbs. GVWR (optional under 10,000 lbs.). Four-wheel ABS provides straighter stopping capability and greater steering control under most operating conditions. Rear-wheel anti-lock brakes are included under 10,000 lbs. GVWR.

**Service ease.**  
The new two-piece frame rails can accept a new front section as a replacement module, which makes the frame easier to service.

**Color-coded circuits.**  
To help prep the chassis for aftermarket applications, wiring on isolated circuits is color coded. This helps facilitate body installation.

**Efficient wiring.**  
A simpler electrical system features a single module with crash sensors built right in. Critical and non-critical functions are isolated with separate fuses for serviceability.

**New spare tire mount.**  
A new optional crank-up spare tire winch replaces the lever-type carrier with pickup box vehicles for ease of operation.

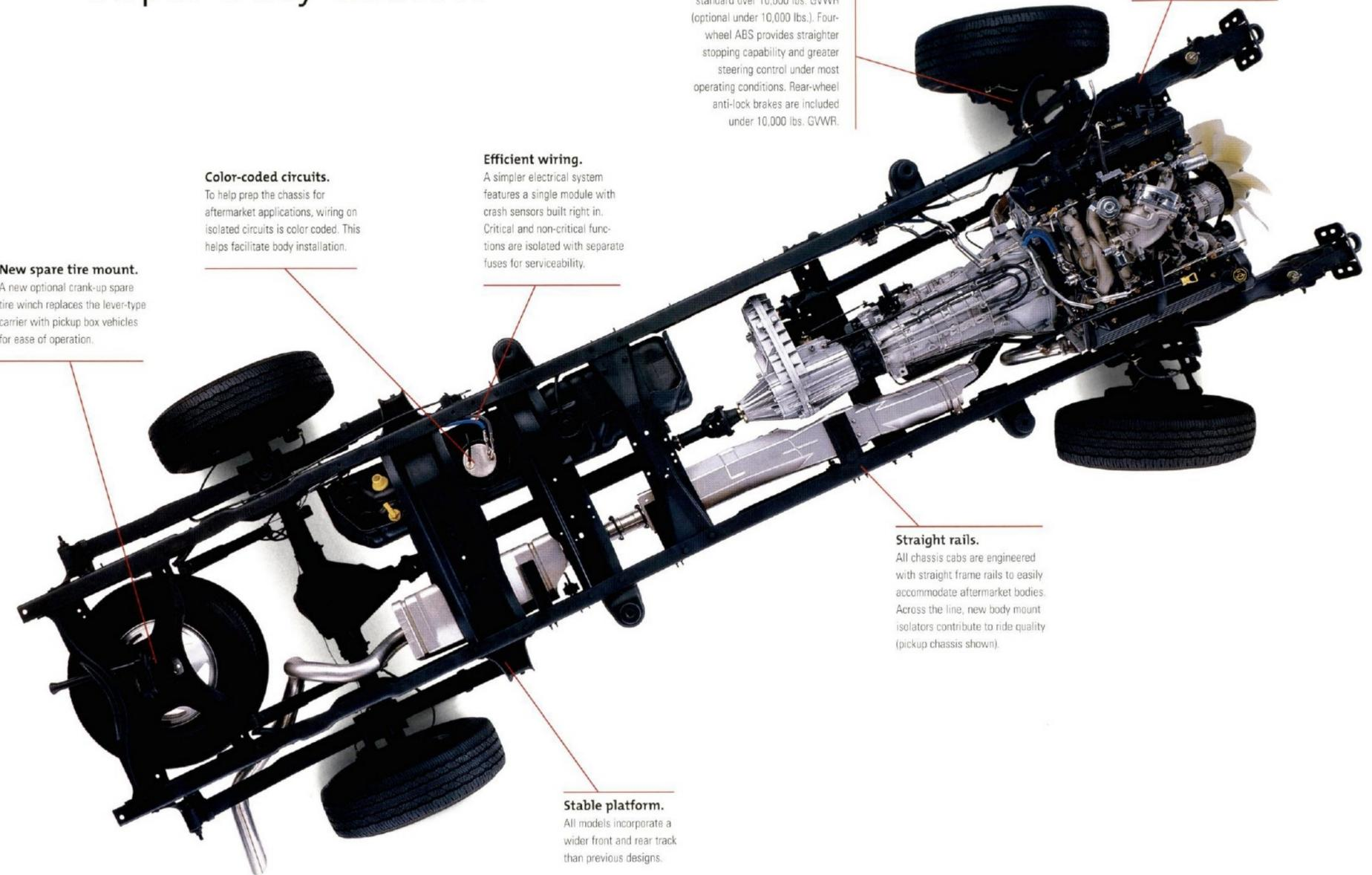

**Straight rails.**  
All chassis cabs are engineered with straight frame rails to easily accommodate aftermarket bodies. Across the line, new body mount isolators contribute to ride quality (pickup chassis shown).

**Stable platform.**  
All models incorporate a wider front and rear track than previous designs.

The Super Duty F-Series chassis is designed for strength and serviceability.

# Built Ford Tough



Super-Duty F-Series has the most 4x4 choices in its class. The available electronic "shift-on-the-fly" system features pulse-vacuum-operated hublocks with manual override capability. A traditional manual-shift transfer case and manual-locking hubs are standard.

The Ford Super Duty chassis combines innovative features with rugged, **time-proven construction** to create the perfect platform for commercial and heavy-duty personal use.

**Wider front and rear tracks** than previous designs enhance stability. **Power 4-wheel disc brakes** are standard across the board, a wider availability than any competitor.

And the special two-piece frame rails accept a new front section as a replacement module for **easier frame servicing**.



Heavy-duty shock absorbers and longer rear leaf springs provide riding comfort and load-carrying capability.



As part of the robust design of the chassis, body mounts and cab brackets are welded (instead of riveted) for increased strength.



Newly designed "closed eye" type tow hooks are attached to the frame for strength (standard on 4x4, optional on 4x2).



Suspension and steering systems offer improved ride, control and directional stability over previous models. All vehicle configurations feature specially tuned suspensions.



F-350 SuperCab Lariat with available Medium Prairie Tan leather seating surfaces.

## Interior



Lariat SuperCab interior with available leather-trimmed upholstery in Medium Prairie Tan.

Regardless of model, choosing Super Duty F-Series assures you of the **roomiest cab available in its class**, a comfortable sanctuary in which to do the thinking part of the job at hand. In fact, things can get downright luxurious if you wish. **Leather-trimmed upholstery** is part of the Lariat package, and available features include a 6-way power driver's seat, speed control and **advanced audio** systems, including a cassette and single CD player with Premium Sound.

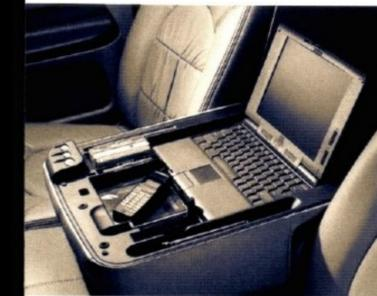

The XLT/Lariat 40/20/40 split bench front seat with standard driver lumbar support includes a center armrest with a storage area that's perfect for a laptop computer or other "office" tools.



The available Premium AM/FM stereo includes a cassette/single CD player with Premium Sound.



Driver and passenger airbags are standard on all pickups (always wear your safety belt). On F-Series models without a full-size rear seat, the passenger airbag deactivation switch must be used when a rear-facing child safety seat is employed.



The instrument panel features integrated cupholders for extra convenience.



The SuperCab rear seat converts to a flat steel load floor in the XLT and Lariat series (optional in the XL). Organizer not included.

# and more power

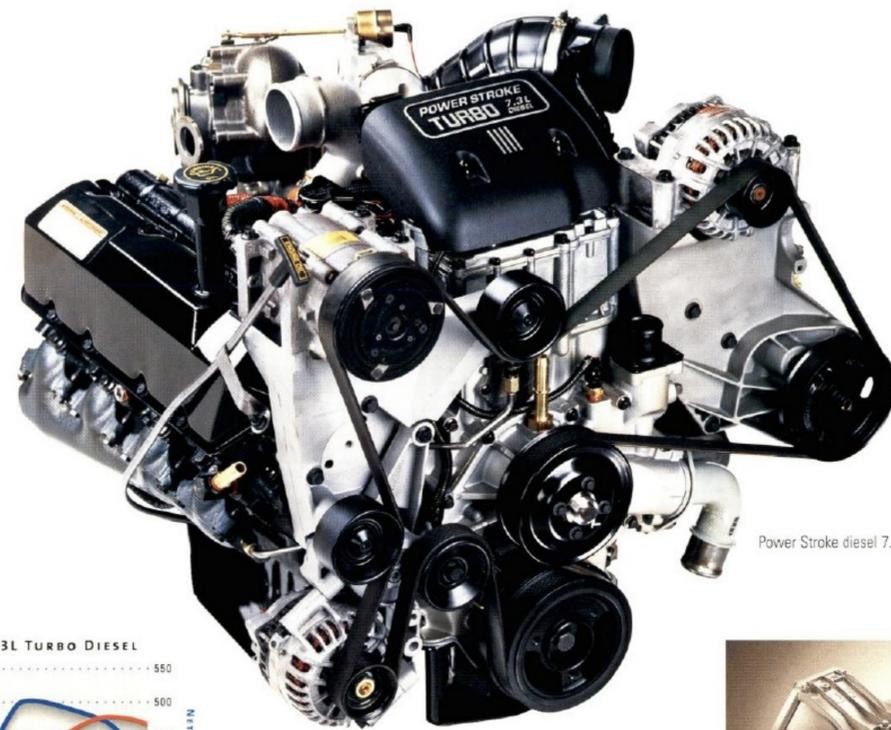

Power Stroke diesel 7.3L\*

The available 7.3L Power Stroke® diesel is the largest diesel and has unsurpassed hp with the most torque in its class. Its big low-end muscle for such applications as grade-climbing and towing is due in part to an advanced fuel injection system, waste-gated turbocharger and intercooler. It's performance you can feel when carrying a fully rated load up a steep grade, at extreme temperatures, at any altitude up to 10,000 feet. And it starts at -10° F without external aid.

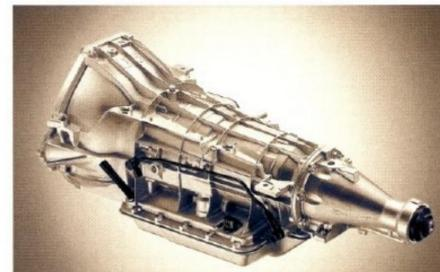
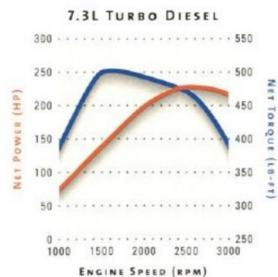

The 4R100 automatic transmission is available with all engines. It's the only automatic in its segment available with an integrated power takeoff provision (offered with 6.8L V10 and 7.3L diesel).

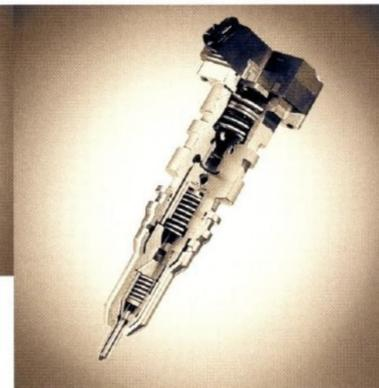

To prevent overboost, the 7.3L Power Stroke's turbocharger employs a waste-gate. This ensures maximum boost is achieved at the low end of the torque range, where it's needed most.

The Power Stroke diesel features the efficiency of the HEUI injector system (Hydraulic-Actuated, Electronically Controlled Unit Injector). The only system like it in its class, it's been redesigned to create quieter diesel operation.

\*Dual alternators only available with Ambulance Package.

# power



Triton V8 and Triton V10

More powerful than their predecessors, the Triton™ 5.4L and 6.8L are the only OHC 8- and 10-cylinder engines in their class. 95% of their pulling power is available at 2,000 rpm for low rpm/high torque muscle. With fail-safe cooling, the engine automatically begins a sequence of cross-bank, alternate-cylinder firings designed to help protect against damage due to coolant loss. And both Triton engines can travel 100,000 miles without a first scheduled tune-up.\*

\*Under normal driving conditions with routine fluid and filter changes.

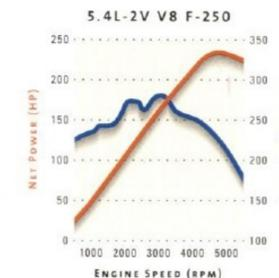

Super Duty F-250/350 4x4 models feature an available electronic "shift-on-the-fly" system, the only trucks over 8,700 lbs. GVWR to do so.

Triton crankshafts feature the strength of forged steel for reliability and durability.

Each Triton engine features a cast-iron engine block, a single overhead cam (SOHC) design and a specially tuned induction system for low rpm/high torque performance.

# power & durability

Today, commercial truckers expect a certain level of "creature comforts" in the vehicles they spend a good part of their time in. And while this is certainly something to consider, power and durability remain the heart and soul of these workhorses. Super Duty F-Series trucks, like all Ford products, have been designed to provide years of tough, capable, dependable service.

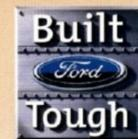

# Ford Partners in Performance



## OFFICIAL TRUCK OF NASCAR

Ford F-Series and NASCAR recently reached their 50-year anniversaries, and we're celebrating together. F-Series is now the Official Truck of NASCAR.



## Future Farmers of America

Ford and the Future Farmers of America go back a long way. FFA has had our enthusiastic support for 50 years. For those same 50 years, farmers all over America have been putting Ford F-Series to work. It's a perfect partnership - a good tough truck for some good tough work. With a new Ford Truck Scholarship Fund benefiting young FFA members, we're reaffirming our commitment to the American Farmer.



When we race, you win.

Racing, as a proving ground, is the best way to test Ford technology to the limit. This racing technology is applied to production trucks and brings proven performance to the Ford trucks you drive.

Tougher, more durable trucks, components and processes are now in production because of what we've learned in off-road racing.

These include suspension tuning, the shifter on the five-speed transmission, disc brake pad material, disc brake rotor casting process, as well as non-asbestos clutch disc friction material.

The F-Series E40D automatic transmission was tested in off-road racing, and 27 improvements were made to increase durability. Motorcraft consumer products, like spark plugs, batteries, silicone brake fluid, manual transmission fluid and wheel bearing grease have been developed or improved by Ford's involvement in racing.

### F-150/250 CAB CONFIGURATIONS

#### F-150 REGULAR CAB

	STYLESIDE	FLARESIDE
4X2		
4X4		

#### F-150 SUPERCAB

	STYLESIDE	FLARESIDE
4X2		
4X4		

#### F-250 REGULAR CAB

	STYLESIDE
4X2	
4X4	

#### F-250 SUPERCAB

	STYLESIDE
4X2	
4X4	

### SUPER DUTY CAB CONFIGURATIONS

#### F-250 PICKUP CHASSIS CAB

	PICKUP			CHASSIS CAB		
	REGULAR CAB	SUPER CAB	CREW CAB	REGULAR CAB	SUPER CAB	CREW CAB
SRW 4X2						
4X4						

#### F-350 PICKUP CHASSIS CAB

	PICKUP			CHASSIS CAB		
	REGULAR CAB	SUPER CAB	CREW CAB	REGULAR CAB	SUPER CAB	CREW CAB
SRW 4X2						
4X4						
DRW 4X2						
4X4						

#### F-450 CHASSIS CAB F-550 CHASSIS CAB

	F-450 CHASSIS CAB		F-550 CHASSIS CAB	
	REGULAR CAB	CREW CAB	REGULAR CAB	CREW CAB
DRW 4X2				
4X4				

FORD EXCLUSIVE MODEL OFFERING

## Dealer Accessories for F-150 & F-250



Your Ford Dealer can show you many ways to  
**personalize your new vehicle.**

The features shown on these pages are just a few.

Dealer-installed Ford-brand accessories are made

with a commitment to quality, and they're

covered by the new vehicle limited warranty.

**See your Ford Dealer** for more

information and a copy of the warranty.



The high-density bedliner helps protect the inside of your pickup box.



Step/sill plates provide extra traction and help protect lower door jambs from those pesky scuffs and scratches.



Diamond plate running boards give your F-Series a tougher, more aggressive look.



The tonneau cover provides extra security as well as some added protection in bad weather.



Splash guards are an economical way to protect your vehicle's lower body finish.

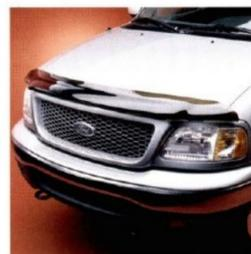

This hood deflector helps protect your F-Series' paint finish from chipping.



This cargo net secures items like tools and hard hats inside the pickup box.



The front end cover helps protect the vehicle's surface from stones and other road debris.



Molded color-keyed cab steps add style while making it easier to get in and out of the cab.

## Dealer Accessories for Super Duty F-250 - F-550



Rated for a 6,000-pound towing capacity and a 600-pound tongue capacity, the rear step bumper provides convenient access to the pickup box. Also available in chrome as well as black painted or silver painted.



The high-density bedliner helps protect the inside of your pickup box from those unwanted but unavoidable chips and dings.



Bed rails come in both diamond plate and tubular designs. They offer good looks and maximum protection for the pickup box.



Tubular running bars reduce step height and allow easier entry and exit. They bolt to existing holes in the chassis. Available in chrome-plated or black.



The bedliner/tailgate kit is custom-fitted protection for both the pickup box and tailgate. Ideal for the occasional work detail.



Side window deflectors help keep water away from the windows for a better view of what's going on.



The diamond plate tool box is made of heavy-gauge aluminum. A reinforced lid and gas cylinders provide easy opening and closing. A rubber mat on the box floor helps prevent items from shifting around. Lockable.



The front box protector is made of powder-coated aluminum. It guards the top edge and inside front wall of pickup box. Installs quickly and easily.



The tonneau cover provides extra security as well as added protection in bad weather.



The Class III receiver-style trailer hitch bolts directly to the frame and requires no welding. Trailer balls ordered separately. Also available is a Class IV hitch.



Running boards in various styles are available to add both a lower step-up and a touch of style to your truck. Color-keyed molded shown. Also available: diamond plate, blade and chrome tubular.



This wraparound hood deflector helps protect your vehicle's paint finish from chipping.

## F-150/F-250 Paint Colors

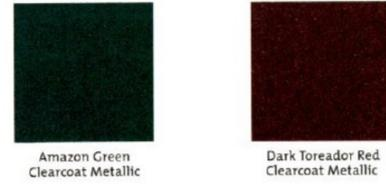
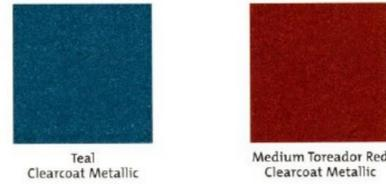
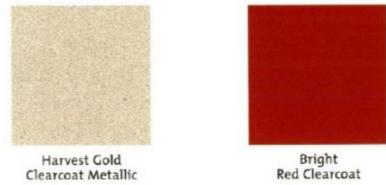

EXTERIOR PAINT	INTERIOR TRIM			
	Medium Prairie Tan	Dark Denim Blue	Medium Graphite	Dark Graphite
Oxford White Clearcoat	•	•	•	•
Silver Clearcoat Metallic		•	•	•
Harvest Gold Clearcoat Metallic	•		•	•
Bright Red Clearcoat	•		•	•
Teal Clearcoat Metallic			•	•
Medium Toreador Red Clearcoat Metallic	•		•	•
Amazon Green Clearcoat Metallic	•		•	•
Dark Toreador Red Clearcoat Metallic	•		•	•
Black Clearcoat	•	•	•	•
Deep Wedgewood Blue Clearcoat Metallic	•	•	•	•

### F-150 Wheels

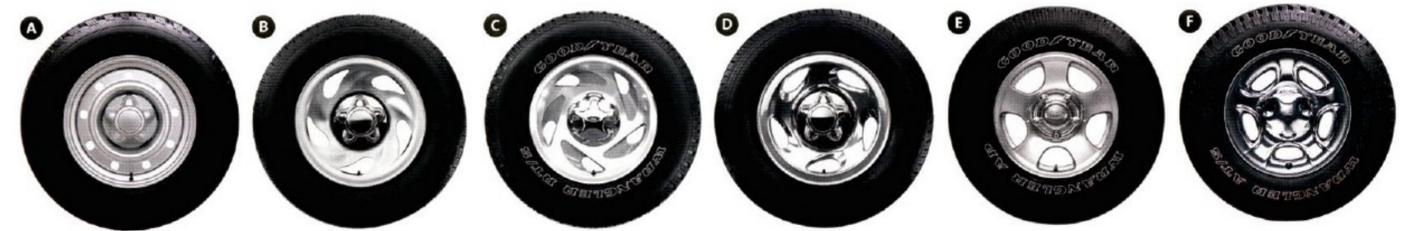

- A** 16" argent painted steel with argent hub (standard on Work Series)
- B** 16" argent styled steel with chrome hub (standard on XL)
- C** 17" cast aluminum with chrome hub (included with XLT Sport Group)\*
- D** 16" polished aluminum with chrome hub (standard on XLT and included with XL Sport Group)\*
- E** 16" cast aluminum with chrome hub (standard on Lariat, optional with XLT)
- F** 17" chromed steel with chrome hub (with optional 4x4 Off-Road Equipment Group)

\*Late availability

### F-250 Wheels



- A** 16" argent styled steel with argent hub (Work Series)
- B** 16" argent styled steel with chrome hub (XL)
- C** 16" chrome styled steel with chrome hub (XLT, Lariat, optional with XL)

## F-150 Series/Trim Levels

### Work Series

- 4.2 SEFI V6, 5-speed manual overdrive transmission
- P235/70R16SL BSW all-season tires (5)
- Vinyl bench seat (2 colors)
- AM/FM stereo/clock/2 speakers
- Rear bench seat (SuperCab models only)
- Argent grille and front bumper
- Argent rear step bumper
- Argent steel wheels (5)
- Interval wipers
- Pickup box rail/tailgate moldings
- Trailer tow wiring - 4 pin
- Wheel opening moldings (4x4)
- Black vinyl sun visors

### XL (Work Series features plus)

- Cloth front bench seat (4 colors)
- Chrome grille trim and chrome front bumper
- Chrome rear step bumper
- Styled steel wheels
- Underhood light
- Interior dome light, dual map lights
- Map pockets in door trim
- Cloth sun visors, LH strap and RH mirror

### XLT (XL features plus)

- Air conditioning (A)
- Cloth 40/60 split bench seat with center storage console, driver's lumbar adjustment
- Color-keyed grille and trim (4x4)
- Fog lamps (4x4)
- Power mirrors
- Polished aluminum wheels (4)
- Color-keyed carpeting
- Tailgate lock, cargo box light
- Rear storage bin (Reg. Cab)
- Tow hooks (4x4)
- Rear quarter flip-out privacy glass windows (SuperCab models only)
- AM/FM stereo/cassette/clock/4 speakers
- Speed control/tilt steering wheel
- 4-wheel anti-lock braking system (A)
- Power windows/locks
- Color-keyed bodyside moldings (Styleside only)
- Tachometer
- Speed-dependent interval wipers

### Lariat (XLT features plus)

- 40/60 split bench seat with front leather seating surfaces (vinyl SuperCab rear seat)
- Five-spoke cast aluminum wheels (4)
- Remote Keyless Entry system
- 4.6L SEFI Triton V8 engine (A)
- 4-speed auto overdrive (A)
- 3.55 rear axle
- Color-keyed grille trim (4x2/4x4)
- Color-keyed, carpeted floor mats
- Autolamp and power driver's seat
- Color-keyed, leather-wrapped steering wheel
- Power signal mirrors, color-keyed
- P255/70R16SL DWL all-season tires (BSW spare 4x2; five all-terrain 4x4)
- Premium AM/FM stereo/single CD/ Premium Sound/ clock/4 speakers

## F-150/F-250 Features and Options

Exterior Features	Work Series	XL	XLT	Lariat
<b>Front bumper</b> argent painted chrome	S	-	-	-
<b>Rear step bumper</b> argent painted chrome	S	-	-	-
<b>Mirrors</b> black, manual chrome, power (XLT 4x2) color-keyed, power (XLT 4x4) color-keyed, power signal	S	S	-	-
<b>Moldings</b> color-keyed bodyside (Styleside only) argent wheel openings (4x4) color-keyed wheel openings (XLT 4x4; Lariat 4x2/4x4)	S	S	S	S
<b>Wheels (F-150)</b> argent painted (5) with argent hub (4) argent styled (5) with chrome hub (4) polished aluminum with chrome hub (4) cast aluminum with chrome hub (4)	S	-	-	-
<b>Wheels (F-250)</b> argent styled (5) with argent hub (4) argent styled (5) with chrome hub (4) chrome styled steel with chrome hub (4)	S	-	-	-
Two-tone paint, lower	-	-	0	0
Four doors (SuperCab)	S	S	S	S
Rear quarter windows with privacy flip-out glass (SuperCab)	-	-	S	S
Sliding rear window	0	0	0	0
<b>Pickup box features:</b> protective bed rail and tailgate top moldings; horizontal pockets and vertical slots in side panels for special loading; tie-down hooks	S	S	S	S
Removable tailgate with black handle	S	S	S	S
Lockable tailgate (1)	-	0	S	S
Front tow hooks (4x4)	-	0	S	S
Fog lamps (4x4)	-	0	S	S
Cab steps	-	-	0	0
Trailer tow wiring, 4-pin connector	S	S	S	S
High-mount stop lamp	S	S	S	S
Cargo box light (1)	-	0	S	S
"Snapless" tonneau cover <small>(1) Offered as "Convenience Group" on XL</small>	-	0	0	0
<b>Interior Features</b>				
<b>Door trim</b> integral armrest map pocket (two with XLT and Lariat) vinyl upper, curb light	S	S	S	S
<b>Floor trim</b> black vinyl black vinyl mat (carpet delete) floor mats, carpeted, color-keyed color-keyed carpet color-keyed carpet; carpeted floor mats	S	S	-	-
Air conditioning	0	0	A	S
Speed control/tilt steering wheel	0	G	S	S
6-way power driver's seat/autolamp system	-	-	0	G
Rear storage bin (Regular Cab)	-	-	S	S
Interval wipers (speed-dependent on XLT and Lariat)	S	S	S	S
<b>Gauges</b> fuel, voltmeter, temperature, oil pressure tachometer	S	S	S	S

S = Standard 0 = Optional G = Equipment Group Feature A = Additional Equipment At No Charge  
\*Always wear your safety belt and deactivate the passenger airbag when using a rear-facing child safety seat.

Interior Features Cont.	Work Series	XL	XLT	Lariat
Powerpoint auxiliary outlet	S	S	S	S
Height-adjustable front shoulder belts	S	S	S	S
Dual instrument panel cupholders	S	S	S	S
Power windows ("one-touch-down" driver's side) and power door locks	-	-	S	S
<b>Seating Arrangements</b>				
Vinyl bench seat	S	-	-	-
Cloth bench seat	-	S	-	-
40/60 cloth split bench seat with recliners; center armrest with cupholder, storage compartment and driver's manual lumbar adjustment	-	0	S	-
40/60 leather-trimmed split bench seat with recliners; center armrest with cupholder, storage compartment and driver's manual lumbar adjustment	-	-	-	S
Captain's chairs with console and driver's manual lumbar adjustment (cloth XLT, leather-trimmed Lariat)	-	-	0	0
Rear 40/60 split bench seat (SuperCab)	S	S	S	S
Rear seat delete (SuperCab)	0	-	-	-
<b>Audio Systems</b>				
AM/FM stereo	S	S	-	-
AM/FM stereo/cassette	-	0	S	-
Premium AM/FM stereo/single CD player/Premium Sound	-	0	0	S
Premium AM/FM stereo/cassette/6-disc CD changer/Premium Sound	-	-	0	0
<b>Safety and Security Features</b>				
SecuriLock <sup>®</sup> passive anti-theft	S	S	S	S
Second Generation Depowered driver and right front passenger airbags*	S	S	S	S
Rear anti-lock braking system	S	S	-	-
4-wheel anti-lock braking system	0	0	A	A
Remote Keyless Entry system	-	-	0	S
<b>F-150 Performance Features</b>				
4.2L V6/5-speed manual OD	S	S	S	-
4.2L V6/4-speed auto OD	0	0	0	-
4.6L V8/5-speed manual OD (std. in SuperCab 4x4s)	0	0	0	-
4.6L V8/4-speed auto OD	0	0	0	A
5.4L V8/4-speed auto OD	-	0	0	0
Electric shift-on-the-fly 4x4	-	-	0	0
3.55 limited slip rear axle	0	0	0	0
3.73 limited slip rear axle	-	-	0	0
Engine block heater (includes heavy-duty battery)	0	0	0	0
Skid plates (transfer case and fuel tank) (4x4)	0	0	0	0
Optional bi-fuel tank configuration (propane or natural gas only)	0	0	0	0

## F-150/F-250 Payloads & Towing

### Equipment Groups

**4x4 Off-Road Equipment Group:** LT265/70R17C OWL all-terrain tires with 17" steel chromed wheels (4); skid plates (fuel tank, transfer case and frame front crossmember); HD shock absorbers; 3.55 rear axle ratio (3.73 axle ratio with 5.4L engine); 4x4 Off-Road decal (except Lariat)

**Sport Group\*:** available on XL and XLT Regular Cab and SuperCab, SWB only. Includes color-keyed front and rear bumpers, grille surround and mirrors, fog lamps (4x4); decal (available in black bright red, white, silver); XL includes V6, color-keyed grille insert, 16" polished aluminum wheels, P255 OWL all-season (4x2) or all-terrain (4x4) tires. XLT includes V6 or V8, black mesh grille insert, 17" cast aluminum wheels, P275 all-season (4x2) or P285 OWL all-terrain (4x4) tires; 4x4 decal

**Convenience Group:** speed control, tilt steering wheel, cargo box light, tailgate lock

**Payload Package #2 (Regular Cab 4x2 V6)**

**Payload Package #3 (139" wheelbase Regular Cab 4x2 V8)**

**Class III Trailer Towing Group: 7-pin wiring harness connector, frame-mounted hitch receiver; Heavy-Duty Electrical/Cooling Group; heavy-duty shock absorbers**

**HD Electrical/Cooling Group:** 72 amp-hr. battery; super engine cooling; auxiliary automatic transmission oil cooler

**Snow Plow Prep Package:** HD Electrical/Cooling Group; P255/70R16SL OWL all-terrain tires (includes 3.55 axle ratio); styled steel wheels (Work Series, XLT V8 only); heavy-duty shock absorbers; 3,900-lb. front GVWR

**Bi-fuel prep:** available on 4x2/4x4 Styleside, Regular Cab, 139" wheelbase only. 5.4L V8 bi-fuel prep engine and propane fuel system or natural gas fuel system required

### F-250 Performance Features

	Work Series	XL	XLT	Lariat
4.6L V8/5-speed manual OD	S	S	S	-
4.6L V8/4-speed auto OD*	0	0	0	A
5.4L V8/4-speed auto OD	0	0	0	0
Electric shift-on-the-fly 4x4	-	-	0	0
3.73 rear axle or 3.73 limited slip rear axle	0	0	0	0
Engine block heater (includes heavy-duty battery)	0	0	0	0
Payload Package #2 (139" wheelbase Regular Cab 4x2)	0	0	0	-
Rear load-leveling suspension	-	-	0	0
Skid plates (transfer case and fuel tank) (4x4)	0	0	0	0
<b>Class III Trailer Towing Group:</b> 7-pin wiring harness connector; frame-mounted hitch receiver; Heavy-Duty Electrical/Cooling Package	0	0	0	0
<b>HD Electrical/Cooling Group:</b> heavy-duty 72-amp-hr. battery; super engine cooling; auxiliary auto transmission oil cooler	0	0	0	0
<b>Snow Plow Prep Package:</b> HD Electrical/Cooling Package; LT245/75R16D OWL all-terrain tires; 4,150-lb. front GAWR	0	0	0	-
<b>Bi-fuel prep:</b> available on 4x2/4x4 Regular Cab/SuperCab, 5.4L V8 bi-fuel prep engine and propane fuel system or natural-gas fuel system required	0	0	0	0
Optional tank configuration (propane or natural-gas)	0	0	0	0

### F-250 Performance Features Cont.

5.4L natural-gas vehicle: available on 4x2 Regular Cab only (5.4L natural-gas engine required)

### F-150 Styleside Payload Package Selector

	Payload Package	Payload (lbs.)**	GVWR (lbs.)	Avail. Engine(s)	Tires (min.)
<b>Regular Cab 4x2</b> 120" wheelbase; 6 1/2' box	#1	1,675	5,600	4.2L	P235/70R16SL BSW
	#1	2,045	6,050	4.6L	P235/70R16SL BSW
	#1	1,890	6,050	5.4L	P235/70R16SL BSW
	#2	2,005	6,000	4.2L	P255/70R16SL OWL
139" wheelbase; 8' box	#1	1,555	5,600	4.2L	P235/70R16SL BSW
	#1	1,930	6,050	4.6L	P235/70R16SL BSW
	#1	1,785	6,050	5.4L	P235/70R16SL BSW
	#2	1,885	6,000	4.2L	P255/70R16SL OWL
#3	#3	2,375	6,600	4.6L <sup>(1)</sup>	P255/70R16SL OWL
	#3	2,285	6,600	5.4L	P255/70R16SL OWL
	#3	2,285	6,600	5.4L	P255/70R16SL OWL
<b>Regular Cab 4x4</b> 120" wheelbase; 6 1/2' box	#1	1,700	6,000	4.2L	P235/70R16SL BSW
	#1	1,870	6,250	4.6L	P235/70R16SL BSW
	#1	1,760	6,300	5.4L	P235/70R16SL BSW
	#1	1,615	6,000	4.2L	P235/70R16SL BSW
#1	#1	1,790	6,250	4.6L	P235/70R16SL BSW
	#1	1,675	6,300	5.4L	P235/70R16SL BSW
	#1	1,780	6,000	4.2L	P235/70R16SL BSW
#1	#1	1,755	6,050	4.6L	P235/70R16SL BSW
	#1	1,840	6,300	5.4L	P235/70R16SL BSW
	#1	1,605	6,000	4.2L	P235/70R16SL BSW
157" wheelbase; 8' box	#1	1,575	6,050	4.6L	P235/70R16SL BSW
	#1	1,660	6,300	5.4L	P235/70R16SL BSW
	#1	1,635	6,250	4.6L	P235/70R16SL BSW
#1	#1	1,725	6,500	5.4L	P235/70R16SL BSW
	#1	1,440	6,250	4.6L	P255/70R16SL OWL
	#1	1,550	6,500	5.4L	P255/70R16SL OWL
<b>SuperCab 4x4</b> 139" wheelbase; 6 1/2' box	#1	1,635	6,250	4.6L	P235/70R16SL BSW
	#1	1,725	6,500	5.4L	P235/70R16SL BSW
	#1	1,440	6,250	4.6L	P255/70R16SL OWL
	#1	1,550	6,500	5.4L	P255/70R16SL OWL
157" wheelbase; 8' box	#1	1,575	6,050	4.6L	P235/70R16SL BSW
	#1	1,660	6,300	5.4L	P235/70R16SL BSW
	#1	1,635	6,250	4.6L	P235/70R16SL BSW
	#1	1,725	6,500	5.4L	P235/70R16SL BSW
#1	#1	1,440	6,250	4.6L	P255/70R16SL OWL
	#1	1,550	6,500	5.4L	P255/70R16SL OWL
	#1	1,550	6,500	5.4L	P255/70R16SL OWL

### F-250 Styleside Payload Package Selector

	Payload Package	Payload (lbs.)**	GVWR (lbs.)	Avail. Engine(s)	Tires (min.)
<b>Regular Cab 4x2</b> 139" wheelbase; 8' box	#1	2,595	6,950	4.6L/5.4L	P255/70R16SL BSW
	#1	2,780 <sup>(1)</sup>	7,650	5.4L	LT245/75R16D BSW
	#2	3,295	7,700	4.6L/5.4L	LT245/75R16D BSW
<b>Regular Cab 4x4</b> 139" wheelbase; 8' box	#1	2,475	7,200	4.6L/5.4L	LT245/75R16D BSW
	#2	2,615	7,700	5.4L	LT245/75R16D BSW
<b>SuperCab 4x2</b> 139" wheelbase; 6 1/2' box	#1	2,280	6,800	4.6L/5.4L	P255/70R16SL BSW
	#2	2,935	7,500	4.6L/5.4L	LT245/75R16D BSW
<b>SuperCab 4x4</b> 139" wheelbase; 6 1/2' box	#1	2,305	7,200	4.6L/5.4L	LT245/75R16D BSW
	#2	2,645	7,700	5.4L	LT245/75R16D BSW

\* Late availability.

\*\* Maximum allowable weight of people, cargo and body equipment, and is reduced by the weight of optional equipment.

(1) Available with automatic transmission only (2) NGV only.

### F-150 Flareside Payload Package Selector

	Payload Package	Payload (lbs.)**	GVWR (lbs.)	Avail. Engine(s)	Tires (min.)
<b>Regular Cab 4x2</b> 120" wheelbase; 6 1/2' box	#1	1,650	5,600	4.2L	P235/70R16SL BSW
	#1	2,020	6,050	4.6L	P235/70R16SL BSW
	#1	1,875	6,050	5.4L	P235/70R16SL BSW
	#2	1,980	6,000	4.2L	P255/70R16SL OWL
<b>Regular Cab 4x4</b> 120" wheelbase; 6 1/2' box	#1	1,675	6,000	4.2L	P235/70R16SL BSW
	#1	1,845	6,250	4.6L	P235/70R16SL BSW
	#1	1,745	6,300	5.4L	P235/70R16SL BSW
	#1	1,755	6,000	4.2L	P235/70R16SL BSW
<b>SuperCab 4x2</b> 139" wheelbase; 6 1/2' box	#1	1,730	6,050	4.6L	P235/70R16SL BSW
	#1	1,825	6,300	5.4L	P235/70R16SL BSW
	#1	1,755	6,000	4.2L	P235/70R16SL BSW
<b>SuperCab 4x4</b> 139" wheelbase; 6 1/2' box	#1	1,610	6,250	4.6L	P235/70R16SL BSW
	#1	1,710	6,500	5.4L	P235/70R16SL BSW

### F-150 Maximum Trailer Weights

	Axle Ratio	GCWR Max.	Regular Cab 4x2	Regular Cab 4x4	SuperCab 4x2	SuperCab 4x4
<b>Automatic</b> 4.2-liter SEFI V6	3.31	9,000	4,800	-	4,400	-
	3.55	10,000	5,800	5,300	5,400	-
	3.08	10,000	5,600	-	5,300	-
4.6-liter SEFI V8	3.55	11,500 <sup>(1)</sup>	7,200	6,800	6,800	6,500
	3.55	11,000 <sup>(2)</sup>	-	6,300	-	6,000
	3.08	11,000	6,800	-	6,200	-
5.4-liter SEFI V8	3.55	12,700	8,300	7,900	7,900	7,600
	3.73	12,700	-	7,800	-	7,600
	3.08	12,700	-	7,800	-	7,600
<b>Manual</b> 4.2-liter SEFI V6	3.08	6,500	2,300	-	2,000	-
	3.31	7,200	-	1,900	-	-
	3.55	7,800	3,600	3,200	3,300	-
4.6-liter SEFI V8	3.08	6,500	2,200	-	1,900	-
	3.55	7,800	3,500	3,100	3,200	2,800
	3.73	12,700	-	7,800	-	7,600

(1) With 16" tires. (2) With 17" tires.

### F-250 Maximum Trailer Weights

	Axle Ratio	GCWR Max.	Regular Cab 4x2	Regular Cab 4x4	SuperCab 4x2	SuperCab 4x4
<b>Automatic</b> 4.6-liter SEFI V6	3.31	10,500	5,800	5,500	5,700	5,300
	3.73	12,000	7,300	7,000	7,200	6,800
	3.31	12,000	7,200	6,900	7,100	6,700
5.4-liter SEFI V8	3.73	13,500	8,700	8,300	8,600	8,200
	3.31	7,200	2,500	2,200	2,400	2,000
<b>Manual</b> 4.6-liter SEFI V8	3.73	7,800	3,100	2,800	3,000	2,600
	3.31	7,200	2,500	2,200	2,400	2,000

Note: Engine/axle ratio combinations may not be available in all areas. See your dealer for required equipment/frontal area considerations. All maximum trailer weights shown must be reduced by passenger and cargo weight in the towing vehicle. The combined weight of the towing vehicle (including hitch, passengers and cargo) and the loaded trailer must not exceed the Gross Combined Weight Rating (GCWR).

S = Standard O = Optional G = Equipment Group Feature A = Additional Equipment At No Charge

## F-150/F-250 Technical Features

### F-150/250 4x2 Features

	Regular Cab	SuperCab
Front suspension	Twin-forged independent short/long arm (SLA) with forged upper and stamped steel control arms	Twin-forged independent short/long arm (SLA) with forged upper and stamped steel lower control arms
Shock absorbers	Gas-pressurized	Gas-pressurized
Stabilizer bar	Front	Front
Steering	Power	Power
Brakes: Work Series, XL	Power with rear anti-lock; 4-wheel anti-lock optional	Power with rear anti-lock; 4-wheel anti-lock optional
XLT, Lariat	Power with 4-wheel anti-lock	Power with 4-wheel anti-lock
Alternator	115 amp (V6), 110 amp (V8)	115 amp (V6), 110 amp (V8)
Maintenance-free battery With battery-saver	58 amp-hr. (540 CCA) standard 72 amp-hr. (650 CCA) optional	58 amp-hr. (540 CCA) standard 72 amp-hr. (650 CCA) optional
Fuel tank	F-150: 25.0 gals. 6 1/2' box F-150: 30.0 gals. 8' box F-250: 30.0 gals. 8' box	25.0 gals. 6 1/2' box 30.0 gals. 8' box 25.0 gals. 6 1/2' box
Wheels (5)	F-150: 7.0J 5-hole F-250: 7.0J 7-hole	7.0J 5-hole 7.0J 7-hole

### F-150/250 4x4 Features

	Regular Cab	SuperCab
Front suspension	Twin-forged independent short/long arm (SLA) with forged upper and cast-iron lower control arms; solid steel torsion bars	Twin-forged independent short/long arm (SLA) with forged upper and cast-iron lower control arms; solid steel torsion bars
Shock absorbers	Gas-pressurized	Gas-pressurized
Stabilizer bar	Front	Front
Steering	Power	Power
Brakes: Work Series, XL	Power with rear anti-lock; 4-wheel anti-lock optional	Power with rear anti-lock; 4-wheel anti-lock optional
XLT, Lariat	Power with 4-wheel anti-lock	Power with 4-wheel anti-lock
4x4 system	Center disconnect, manual shift-on-the-fly; electric shift-on-the-fly system optional	Center disconnect, manual shift-on-the-fly; electric shift-on-the-fly system optional
Transfer case	2-speed	2-speed
Alternator	115 amp (V6), 110 amp (V8)	115 amp
Maintenance-free battery With battery-saver	58 amp-hr. (540 CCA) standard 72 amp-hr. (650 CCA) optional	58 amp-hr. (540 CCA) standard 72 amp-hr. (650 CCA) optional
Fuel tank	F-150: 24.5 gals. 6 1/2' box F-150: 30.0 gals. 8' box F-250: 30.0 gals. 8' box	25.0 gals. 6 1/2' box 30.0 gals. 8' box 25.0 gals. 6 1/2' box
Wheels (5)	F-150: 7.0J 5-hole F-250: 7.0J 7-hole	7.0J 5-hole 7.0J 7-hole

### F-150/250 Powertrains

	4.2L V6	4.6L Triton V8	5.4L Triton V8
Compression ratio	9.3:1	9.0:1	9.0:1
Fuel-injection system	Sequential EFI	Sequential EFI	Sequential EFI
Horsepower	205 @ 4,750 rpm	220 @ 4,500 rpm	260 @ 4,500 rpm
Torque lbs./ft.	250 @ 3,000 rpm	290 @ 3,250 rpm	345 @ 2,300 rpm

### F-150 Powertrain Availability by Model

	Regular Cab 4x2			Regular Cab 4x4			SuperCab 4x2			SuperCab 4x4		
	Work Series	XL	XLT Lariat	Work Series	XL	XLT Lariat	Work Series	XL	XLT Lariat	Work Series	XL	XLT Lariat
4.2L V6/5-speed manual OD	S	S	S	-	S	S	S	-	S	S	S	-
4.2L V6/4-speed automatic OD	0	0	0	-	0	0	0	-	0	0	0	-
4.6L V8/5-speed manual OD	0	0	0	-	0	0	0	-	0	0	0	-
4.6L V8/4-speed automatic OD	0	0	0	A	0	0	0	A	0	0	0	A
5.4L V8/4-speed automatic OD	-	0	0	0	0	0	0	0	-	0	0	0
5.4L V8 bi-fuel prep engine/4-speed automatic OD	0	0	0	0	0	0	0	0	0	0	0	0

### F-250 Powertrain Availability by Model

|--|

## Super Duty F-250/F-350 Paint Colors

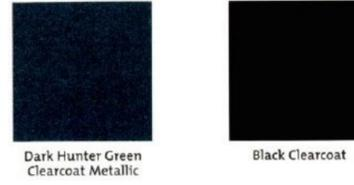
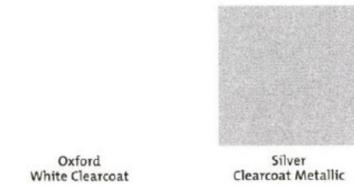

EXTERIOR PAINT	INTERIOR TRIM		
	Denim Blue	Medium Prairie Tan	Medium Graphite
Oxford White Clearcoat	•	•	•
Silver Clearcoat Metallic*	•		•
Light Prairie Tan Clearcoat Metallic		•	
Bright Amber Clearcoat Metallic**		•	
Red Clearcoat Metallic		•	•
Woodland Green Clearcoat Metallic		•	
Dark Hunter Green Clearcoat Metallic		•	•
Black Clearcoat		•	•
Wedgewood Blue Clearcoat Metallic	•		•
Dark Toreador Red Clearcoat Metallic	•	•	

\* Not available on Lariat. All Lariat interiors in Medium Prairie Tan. \*\* Lariat only. See your dealer for availability of two-tone combinations for selected F-250 and F-350 models.

## Super Duty Wheels



- A** 16" deluxe aluminum wheel with chrome hub cover
- B** 16" premium aluminum wheel with chrome hub cover
- C** 16" polished aluminum wheel (DRW)
- D** 16" grey steel wheel with black hub cover
- E** 16" grey steel wheel with full wheel cover
- F** 16" grey steel wheel (F-350 DRW)
- G** 19.5" grey steel wheel (F-450/550 DRW)

## Super Duty F-250/F-350 Equipment Groups

### F-250 XL Regular Cab PEP 600A

- Sealed-beam halogen headlamps
- Solar tinted glass
- Driver's side airbag
- Passenger-side airbag with deactivation switch
- AM/FM stereo/clock/2 speakers
- Flip-out rear quarter window glass (SuperCab)
- Pickup box/cargo light
- Manual foldaway mirrors
- Full instrumentation including tachometer

### F-350 XLT SuperCab PEP 617A

- Cloth 40/20/40 split bench front seat
- Rear fold-down bench seat
- Air conditioning
- Power door locks and power windows
- Speed control and tilt steering wheel
- Deluxe aluminum wheels
- AM/FM stereo cassette/4 speakers

### F-350 Lariat Crew Cab PEP 618A

- Premium aluminum wheels
- Leather-trimmed 40/20/40 split bench front seat
- 6-way power driver's seat
- Remote Keyless Entry system
- Leather-wrapped, color-keyed steering wheel
- Cab steps
- Power foldaway mirrors
- Front tow hooks (4x4)

## Super Duty F-Series Features and Options

Exterior Features	XL	XLT	Lariat
<b>Front bumper</b> argent painted chrome with lower valance	S	-	-
<b>Rear bumper</b> argent rear step chrome rear step	0	-	0
<b>Cab steps</b> argent	0	0	S
<b>Mirrors</b> black, manual foldaway black, power foldaway	S	S	-
<b>Mirrors</b> manual trailer tow power trailer tow	0	0	-
<b>Moldings</b> black bodyside with chrome accent argent top-edge tailgate argent box rail moldings	-	S	S
<b>Wheels (4)</b> steel wheels, black center ornaments full wheel cover deluxe aluminum wheels premium aluminum wheels spare tire and wheel	S	-	-
Sealed-beam halogen headlamps	S	-	-
Aero halogen headlamps	-	S	S
Solar tinted glass	S	S	S
Two-tone paint, lower accent	-	0	0
<b>XL Decor Group:</b> chrome front bumper with lower valance; tow hooks (standard with 4x4); aero halogen headlamps; steel wheels with full wheel covers; locking tailgate	0	-	-
Four doors (SuperCab/Crew Cab)	S	S	S
Quarter/rear windows with flip-out glass (SuperCab)	S	S	S
Privacy glass	-	0	0
Sliding rear window	0	0	0
<b>Pickup box:</b> partitionable and stackable with four tie-down hooks	S	S	S
Removable tailgate	S	S	S
Lockable tailgate	-	S	S
Front tow hooks (4x4)	S	S	S
Front tow hooks (4x2)	0	0	S
Trailer tow wiring, 4-pin connector	S	S	S
High-mount stop lamp	S	S	S
Cargo box light	S	S	S
Underhood service light	-	S	S

### Interior Features

<b>Door trim</b> molded, color-keyed with grab handle, reflector hard armrest deluxe trim with upper and lower map pocket, soft armrest	S	S	S
<b>Floor trim</b> full black vinyl mat full color-keyed carpet	S	-	-
<b>Floor mats:</b> color-keyed, carpeted (includes rear mats with Crew Cab)	-	-	S
Air conditioning	0	P	P

### Interior Features Cont.

	XL	XLT	Lariat
Speed control/tilt steering wheel	0	P	P
6-way power driver's seat	-	0	P
Gauges: tachometer, voltmeter, coolant temperature, oil pressure, fuel, trip odometer	S	S	S
Powerpoint auxiliary outlet	S	S	S
Overhead console: trip computer (compass, distance-to-empty, outside temperature); general storage bin	-	-	S
Height-adjustable front shoulder belts	S	S	S
Dual instrument panel cupholders	S	S	S
Front passenger-side assist handle	S	S	S
Grab handles over rear doors (Crew Cab only)	-	S	S
Power windows ("one-touch-down" driver's side) and power door locks	-	P	S
Back panel storage provisions: hanging bin, storage trays and utility hooks (Regular Cab only)	-	S	S
<b>Steering wheel</b> black vinyl color-keyed leather	S	S	-
<b>Sun visors</b> vinyl cloth with LH strap, RH mirror cloth with LH strap, LH and RH mirrors, LH and RH secondary blade	S	-	-
Color-keyed scuff plates	S	S	S

### Seating Arrangements

Heavy-duty vinyl full bench seat	S	-	-
Heavy-duty cloth or knitted vinyl full bench seat	0	-	-
40/20/40 cloth split bench seat with lumbar support and recliners; center armrest, storage compartment	-	S	S
Luxury captain's chairs with console and lumbar support (cloth XLT, leather-trimmed Lariat)	-	0	0
Leather trimmed 40/20/40 split bench seat	-	-	P
Rear seat, SuperCab (converts to load floor)	0	S	S
Rear seat, Crew Cab (flight bench with forward-folding seat back with XLT, Lariat)	S	S	S

### Audio Systems

AM/FM stereo	S	-	-
AM/FM stereo/cassette	0	S	S
Premium AM/FM stereo/cassette/single CD player/Premium Sound	0	0	0
Radio credit	0	-	-

### Safety and Security Features

Second Generation Depowered airbags*	S	S	S
Rear anti-lock brake system	S	S	S
4-wheel anti-lock brake system	0	0	0
Remote Keyless Entry system	-	0	P

S = Standard 0 = Optional P = Preferred Equipment Package Feature  
\*Always wear your safety belt and deactivate the passenger airbag when using a rear-facing child safety seat in Regular Cab and SuperCab models.

## Super Duty F-Series Features and Options Cont.

Performance Features	XL	XLT	Lariat
5.4L V8/5-speed manual OD	S	S	S
5.4L V8/4-speed electronic auto OD (required in California)	0	0	0
6.8L V10/5-speed manual OD	0	0	0
6.8L V10/4-speed electronic auto OD	0	0	0
7.3L DI turbo diesel/6-speed manual OD	0	0	0
7.3L DI turbo diesel/4-speed electronic auto OD	0	0	0
Electric shift-on-the-fly 4x4	0	0	0
Limited slip rear axle	0	0	0
Engine block heater (standard with diesel engine)	0	0	0
Heavy-duty 78 AH battery	0	0	0
Roof clearance lights	0	0	0
Daytime running lights	0	0	0
License plate bracket	0	0	0
Transmission power take-off provision (available with 6.8L and 7.3L engines with automatic transmission. Standard with manual transmission)	0	0	—
Class IV trailer hitch receiver	0	0	0
<b>Trailer Towing Package:</b> 7-wire harness; front stabilizer bar (4x2); trailer brake wiring/feed kit; heavy-duty 115 amp. alternator (gasoline engines); heavy-duty 78 AH (750 CCA) battery (gasoline engines)	0	0	0
<b>4x4 Off-Road Package:</b> transfer case and fuel tank skid plates; "Off-Road 4x4" decal	0	0	0
<b>4x4 Snow Plow Package:</b> highest front GAWR/springs; auxiliary rear springs; heavy-duty 78 AH (750 CCA) battery (gasoline engines); heavy-duty 115 amp. alternator (gasoline engines)	0	0	0
<b>Camper Package:</b> front stabilizer bar (4x2 only); rear stabilizer bar; auxiliary rear springs; heavy-duty 78 AH (750 CCA) battery (gasoline engines); heavy-duty 115 amp. alternator (gasoline engines); slide-in camper certification	0	0	0
<b>Heavy-Service Suspension Package:</b> front stabilizer bar (4x2); heavy-service front springs; auxiliary rear springs	0	0	0

Features and options shown are for F-350 SRW pickup configurations. Other models (e.g. Chassis Cabs) may vary. See your dealer for details.

Tires	Pickup	Chassis Cab
F-250 LT235/85R16E all-season	S	—
F-350 LT215/85R16E all-season (4x2 DRW)	S	S
F-350 LT235/85R16E all-season (4x4 DRW)	S	S
F-350 LT265/75R16E all-season (SRW)	S	S
F-450 225/70R19.5F all-season	—	S
F-550 225/70R19.5F all-season	—	S

S = Standard 0 = Optional P = Preferred Equipment Package Feature

Powertrain Specifications	5.4L Triton V8	6.8L Triton V10	7.3 Power Stroke V8 diesel
<b>ENGINE</b>	5.4L Triton V8	6.8L Triton V10	7.3 Power Stroke V8 diesel
Type	SOHC	SOHC	OHV
Fuel injection	Sequential electronic	Sequential electronic	High-pressure, 2-stage injector (HEUI)
Engine control system	EEC-V	EEC-V	EEC-V
Induction system	Specially tuned	Specially tuned	Turbocharger, intercooler
Battery	12 volt; 850 cca/72 amp	12 volt; 650 cca/72 amp	Dual 12 volt; 750 cca/78 amp
Alternator	95 amp (115 amp opt.)	95 amp (115 amp opt.)	110 amp (dual 110 amp opt.)
Cooling system	Pressurized series flow	Pressurized series flow	Pressurized series flow
Cylinders	Eight	Ten	Eight
Cylinder head material	Aluminum	Aluminum	Cast iron
Block material	Cast iron	Cast iron	Cast iron
Valve operation	Hydraulic roller	Hydraulic roller	Push rod/rocker arms
Camshaft drive	Silent chain	Silent chain	Gear
Bore	3.55"	3.55"	4.11"
Stroke	4.16"	4.16"	4.18"
Compression ratio	9.0:1	9.0:1	17.5:1
Horsepower (SAE net)	235 @ 4,250	275 @ 4,250	235 @ 2,700
Torque (SAE net)	335 @ 3,000	410 @ 2,650	500 @ 1,600
Recommended fuel	Unleaded	Unleaded	Diesel

Transmission Specifications	M5HD 5-Speed Manual	M6HD 6-Speed Manual	4R100 4-Speed Automatic
<b>TYPE</b>	M5HD 5-Speed Manual	M6HD 6-Speed Manual	4R100 4-Speed Automatic
Gear ratios (:1):			
Low	—	5.79	—
1st	5.72	3.31	2.71
2nd	2.94	2.10	1.54
3rd	1.61	1.31	1.00
4th	1.00	1.00	0.71
5th	0.76	0.72	—
Reverse	5.24	5.23	2.18

Interior Dimensions	Regular Cab	SuperCab	Crew Cab
Head room – front	41.3	41.4	41.4
Leg room – front	40.7	40.7	40.7
Shoulder room – front	68.0	68.0	68.0
Hip room – front	67.4	67.4	67.4
Total/front volume (cu. ft.)	66.1	66.3	66.3
Head room – rear	—	38.5	41.0
Leg room – rear	—	32.4	42.5
Shoulder room – rear	—	68.0	68.0
Hip room – rear	—	67.3	67.3
Rear volume (cu. ft.)	—	49.1	68.6
Total volume (cu. ft.)	66.1	115.4	134.9

## Super Duty F-Series Features and Options Cont.

Suspension – Front	
Type	Twin I-beam (F-250/350, 4x2); solid front axle monobeam (F450/550 4x2, all 4x4)
Axle (rating @ ground)	4,850 lbs. (F-250/350 4x2) 5,400 lbs. (F-450/550 4x2) (6,000 lbs. with 19,000-lb. GVWR) 5,200 lbs. (F-250/350 4x4) 6,000 lbs. (F-450/550 4x4)
Springs	Coil (F-250/350, 4x2); leaf (F-450/550 4x2, all 4x4)
Shock absorbers	1 $\frac{1}{2}$ " gas-type
Stabilizer bar	Standard F-250/350 4x4, F-350 4x2 Chassis Cab, F-450/550; optional in packages on F-250/350 4x2 pickup

Suspension – Rear	
Type	Solid axle
Axle (rating @ ground)	6,830 lbs. (F-250/350 SRW) 9,750 lbs. (F-350 DRW) 11,000 lbs. (F-450) 13,500 lbs. (F-550)
Springs	Leaf
Shock absorbers	1 $\frac{1}{2}$ " gas-type
Stabilizer bar	Standard on F-350 4x4 DRW Pickup, F-350 Chassis Cab, F-450/550; optional in packages on F-250/350 where not standard

Steering	
Type	Haltenberger linkage (4x2), cross-tie linkage (4x4)
Assist	Power
Overall ratio	19.6:1 F-250/350 4x2; 20.3:1 F-450/550 4x2, all 4x4
Turning circle curb-to-curb (ft.)	48.25 w/4x2 137 WB; 70.82 w/4x4 201 WB (range)

Brakes – Front	
Type	4-wheel disc (standard); 4-wheel ABS (standard 10,000 lbs. GVWR and over, optional under 10,000 lbs. GVWR)
Rotor diameter	13.03" (F-250/350); 14.53" (F-450/550)
Lining area (sq. in.)	12.40 (F-250/350); 13.90 (F-450/550)

Brakes – Rear	
Type	4-wheel disc (standard); rear ABS (standard under 10,000 lbs. GVWR) 4-wheel ABS (standard 10,000 lbs. GVWR and over, optional under 10,000 lbs. GVWR)
Rotor diameter	12.83" (F-250/350); 15.55" (F-450/550)
Lining area (sq. in.)	8.68 (F-250/350); 13.90 (F-450/550)

Wheels	
Type	Steel (standard); aluminum on F-250/350 (optional)
Size	16-inch, (F-250/350); 19.5-inch (F-450/550)
No. of studs	8
Bolt circle diameter	170mm, 6.7" (F-250/350); 225mm, 8.85" (F-450/550)

(All dimensions in inches unless otherwise specified)

Fuel Capacity	
Location/capacity	Midship 29 gal. (standard F-250/350 short wheelbase pickup) 36 gal. (standard F-250/350 long wheelbase pickup) Aft-of-rear axle 36 gal. (standard chassis cab) Midship 19 gal. (optional chassis cab in place of 36 gal. tank)

Powertrains					
Model	Engine	4x4 Transfer Case	5-Spd./Man.	6-Spd./Man.	4-Spd./Auto.
F-250/350	5.4L SEFI V8	2-speed man.	S	—	0
F-250/350	6.8L SEFI V10	2-speed man.	0	—	0
F-250/350	7.3L Diesel	2-speed man.	—	0	0
F-450	6.8L SEFI V10	2-speed man.	S	—	0
F-450	7.3L Diesel	2-speed man.	—	0	0
F-550	6.8L SEFI V10	2-speed man.	—	—	S
F-550	7.3L Diesel	2-speed man.	—	0	0

## Pickups/Weights and Dimensions

Regular Cab	F-250 SRW	F-350 SRW	F-350 DRW
Wheelbase (in.)	137	137	137
Max. GVWR (lbs.) 4x2/4x4	8,800	9,900	11,200
Max. payload (lbs.) 4x2/4x4	3,840/3,360	4,930/4,450	5,975/5,495
Overall length (in.)	222.2	222.2	222.2
Max. width (in.)	79.9	79.9	95.5
Axle clearance (in.) 4x2/4x4	8.3/8.3	8.1/8.1	7.0/7.8
Box length(ft.)/volume (cu. ft.)	8/77.7	8/77.7	8/77.7
Box delete option/cab-to-axle (in.)	Yes/56.2	—	Yes/56.2

SuperCab	F-250 SRW	F-250 SRW	F-350 SRW	F-350 SRW	F-350 DRW
Wheelbase (in.)	141.8	158	141.8	158	158
Max. GVWR (lbs.) 4x2/4x4	8,800	8,800	9,900	9,900	11,200
Max. payload (lbs.) 4x2/4x4	3,610/3,165	3,520/3,075	4,700/4,255	4,610/4,165	5,655/5,300
Overall length (in.)	227.0	243.2	227.0	243.2	243.2
Max. width (in.)	79.9	79.9	79.9	79.9	95.5
Axle clearance (in.) 4x2/4x4	8.3/8.3	8.3/8.3	8.1/8.1	8.1/8.1	7.0/7.8
Box length (ft.)/volume (cu. ft.)	6.75/64.7	8/77.7	6.75/64.7	8/77.7	8/77.7
Box delete option/cab-to-axle (in.)	—	Yes/56.2	—	—	Yes/56.2

## Pickups/Weights and Dimensions Cont.

Crew Cab	F-250 SRW	F-250 DRW	F-350 SRW	F-350 DRW	F-450 SRW	F-450 DRW	F-550 SRW	F-550 DRW
Wheelbase (in.)	156.2	172.4	156.2	172.4	156.2	172.4	156.2	172.4
Max. GVWR (lbs.) 4x2/4x4	8,800	8,800	9,900	9,900	11,200	11,200	11,200	11,200
Max. payload (lbs.) 4x2/4x4	3,310/2,865	3,220/2,775	4,400/3,955	4,310/3,865	5,240/4,795	5,150/4,705	5,150/4,705	5,150/4,705
Overall length (in.)	241.4	257.6	241.4	257.6	241.4	257.6	241.4	257.6
Max. width (in.)	79.9	79.9	79.9	79.9	95.5	95.5	95.5	95.5
Axle clearance (in.) 4x2/4x4	8.3/8.3	8.3/8.3	8.1/8.1	8.1/8.1	7.0/7.8	7.0/7.8	7.0/7.8	7.0/7.8
Box length (ft./volume (cu. ft.))	6.75/64.7	8/77.7	6.75/64.7	8/77.7	6.75/64.7	8/77.7	6.75/64.7	8/77.7
Box delete option/cab-to-axle (in.)	-	Yes/56.2	-	-	-	Yes/56.2	-	-

## Chassis Cabs/Weights and Dimensions

Regular Cab	F-350 SRW	F-350 DRW	F-450 SRW	F-450 DRW	F-550 SRW	F-550 DRW	F-550 SRW	F-550 DRW
Wheelbase (in.)	140.8	140.8	164.8	140.8	164.8	200.8	140.8	200.8
Cab-to-axle (in.)	60	60	84	60	84	120	60	84
Max. GVWR (lbs.)								
4x2	9,900	12,500*	12,500*	15,000	15,000	15,000	17,500	19,000
4x4	9,900	12,500*	12,500*	15,000	15,000	15,000	17,500	17,500
Max. payload (lbs.)								
4x2	5,140	6,755	6,675	9,030	8,975	8,640	11,425	12,425
4x4	4,685	6,265	6,215	8,700	8,645	8,310	11,095	10,705
Overall length (in.)	225.7	225.7	249.7	225.7	249.7	285.7	225.7	249.7
Axle clearance (in.)								
4x2	8.1	7.0	7.0	8.0	8.0	8.0	8.0	8.0
4x4	8.1	7.8	7.8	8.0	8.0	8.0	8.0	8.0

### Regular Cab cont.

	F-350 SRW	F-350 DRW	F-450 SRW	F-450 DRW	F-550 SRW	F-550 DRW
Tire width data						
Front tread (in.) 4x2	68.7	68.7	68.7	68.4	68.4	68.4
4x4	68.4	68.4	68.4	68.4	68.4	68.4
Rear tread 4x2/4x4 (in.)	68.1	60.3	60.3	63.4	63.4	63.4
Outside width (in.)						
4x2	79.0	90.7	90.7	93.6	93.6	93.6
4x4	79.0	91.7	91.7	93.6	93.6	93.6

### SuperCab

	F-350 SRW	F-350 DRW
Wheelbase (in.)	161.8	161.8
Cab-to-axle (in.)	60	60
Max. GVWR (lbs.) 4x2/4x4	9,900	12,500*
Max. payload (lbs.) 4x2/4x4	4,815/4,370	6,415/5,975
Overall length (in.)	246.7	246.7
Axle clearance (in.) 4x2/4x4	8.1/8.1	7.0/7.8
Tire width data		
Front tread 4x2/4x4 (in.)	68.7/68.4	68.7/68.4
Rear tread 4x2/4x4 (in.)	68.1	60.3
Outside width 4x2/4x4 (in.)	79.0/79.0	90.7/91.7

### Crew Cab

	F-350 SRW	F-350 DRW	F-450 DRW	F-550 DRW
Wheelbase (in.)	176.2	176.2	176.2	176.2
Cab-to-axle (in.)	60	60	60	60
Max. GVWR (lbs.) 4x2/4x4	9,900	12,500*	15,000	17,500
Max. payload (lbs.) 4x2/4x4	4,520/4,075	6,115/5,680	8,415/8,085	10,815/10,485
Overall length (in.)	261.1	261.1	261.1	261.1
Axle clearance (in.) 4x2/4x4	8.1/8.1	7.0/7.8	8.0/8.0	8.0/8.0
Tire width data				
Front tread 4x2/4x4 (in.)	68.7/68.4	68.7/68.4	68.4/68.4	68.4/68.4
Rear tread 4x2/4x4 (in.)	68.1	60.3	63.4	63.4
Outside width 4x2/4x4 (in.)	79.0/79.0	90.7/91.7	93.6/93.6	93.6/93.6

\*12,500 pounds with 7.3L V8 turbo diesel. Maximum 11,200 pounds with gas engines.

## Super Duty F-250/350 Pickup

### Maximum Loaded Trailer Weight (Lbs.) – Automatic Transmission

ENGINE	AXLE RATIO	GCWR (LBS.)	Regular Cab Pickup				SuperCab Pickup				Crew Cab Pickup									
			F-250 4x2	F-250 4x4	F-350 4x2 SRW	F-350 4x2 DRW	F-350 4x4 SRW	F-350 4x4 DRW	F-250 4x2	F-250 4x4	F-350 4x2 SRW	F-350 4x2 DRW	F-350 4x4 SRW	F-350 4x4 DRW						
5.4L	3.73	13,500	8,200	7,700	8,200	7,900	7,700	7,500	7,800	7,400	7,800	7,600	7,400	7,300	7,500	7,100	7,500	7,300	7,100	6,900
SEFI V8	4.10	15,000	9,700	9,200	9,700	9,400	9,200	9,000	9,300	8,900	9,300	9,100	8,900	8,800	9,000	8,600	9,000	8,800	8,600	8,400
6.8 L	3.73	17,000	11,600	11,100	11,600	11,300	11,100	10,800	11,300	10,800	11,200	10,900	10,800	10,600	11,000	10,500	10,900	10,600	10,500	10,200
V10	4.30	20,000	14,600	14,100	14,600	14,300	14,100	13,800	14,300	13,800	14,200	13,900	13,800	13,600	14,000	13,500	13,900	13,600	13,500	13,200
7.3L V8 DI	3.73	20,000	14,200	13,700	14,100	13,800	13,700	13,400	13,800	13,400	13,800	13,500	13,400	13,200	13,500	13,100	13,500	13,200	13,100	12,800
Turbo Diesel	4.10	20,000	-	-	-	13,800	-	13,400	-	-	-	13,500	-	13,200	-	-	-	13,200	-	12,800

### Maximum Loaded Trailer Weight (Lbs.) – Manual Transmission

ENGINE	AXLE RATIO	GCWR (LBS.)	Regular Cab Pickup				SuperCab Pickup				Crew Cab Pickup									
			F-250 4x2	F-250 4x4	F-350 4x2 SRW	F-350 4x2 DRW	F-350 4x4 SRW	F-350 4x4 DRW	F-250 4x2	F-250 4x4	F-350 4x2 SRW	F-350 4x2 DRW	F-350 4x4 SRW	F-350 4x4 DRW						
5.4L	3.73	13,500	8,300	7,800	8,300	8,000	7,800	7,500	7,900	7,500	7,900	7,700	7,500	7,300	7,600	7,200	7,600	7,400	7,200	7,000
SEFI V8	4.10	15,000	9,800	9,300	9,800	9,500	9,300	9,000	9,400	9,000	9,400	9,200	9,000	8,800	9,100	8,700	9,100	8,900	8,700	8,500
6.8L	3.73	16,500	11,100	10,700	11,100	10,800	10,700	10,300	10,800	10,400	10,800	10,500	10,400	10,100	10,500	10,100	10,500	10,200	10,100	9,800
V10	4.30	20,000	14,800	14,200	14,600	14,300	14,200	13,800	14,300	13,900	14,300	14,000	13,900	13,600	14,000	13,600	14,000	13,700	13,600	13,300
7.3L V8 DI	3.73	20,000	14,100	13,600	14,100	13,800	13,600	13,300	13,800	13,400	13,800	13,500	13,300	13,100	13,500	13,100	13,500	13,200	13,100	12,700
Turbo Diesel	4.10	20,000	-	-	-	13,800	-	13,300	-	-	-	13,500	-	13,100	-	-	-	13,200	-	12,700

\*Fifth wheel trailer weights shown. For conventional towing, trailer weights should not exceed 10,000 pounds.

## Super Duty F-350/450/550 Chassis Cab

### Maximum Loaded Trailer Weight (Lbs.) – Automatic Transmission

ENGINE	AXLE RATIO	GCWR (LBS.)	Regular Chassis Cab							Super Chassis Cab				Crew Chassis Cab												
			F-350 4x2 SRW	F-350 4x4 SRW	F-350 4x2 DRW	F-350 4x4 DRW	F-450 4x2 DRW*	F-450 4x4 DRW*	F-550 4x2 DRW*	F-550 4x4 DRW*	F-350 4x2 SRW	F-350 4x4 SRW	F-350 4x2 DRW	F-350 4x4 DRW	F-350 4x2 SRW	F-350 4x4 SRW	F-350 4x2 DRW	F-350 4x4 DRW								
5.4L	3.73	13,500	7,400	6,900	7,000	6,600	-	-	-	-	-	-	-	7,000	6,600	6,800	6,400	6,700	6,300	6,500	6,100	-	-	-	-	
SEFI V8	4.10	15,000	8,900	8,400	8,500	8,100	-	-	-	-	-	-	-	8,500	8,100	8,300	7,900	8,200	7,800	8,000	7,600	-	-	-	-	
6.8 L	3.73	17,000	10,800	10,300	10,400	9,900	-	-	-	-	-	-	-	10,400	10,000	10,100	9,700	10,100	9,700	9,800	9,400	-	-	-	-	
SEFI V10	4.30	20,000	13,800	13,300	13,400	12,900	-	-	-	-	-	-	-	13,400	13,000	13,100	12,700	13,100	12,700	12,800	12,400	-	-	-	-	
	4.88	24,000	-	-	-	-	16,800	16,400	16,700	16,400	-	-	-	-	-	-	-	-	-	-	-	-	16,200	15,800	16,100	15,800
	5.38	26,000	-	-	-	-	18,800	18,400	18,700	18,400	-	-	-	-	-	-	-	-	-	-	-	-	18,200	17,800	18,100	17,800
7.3L V8	3.73	20,000	13,300	12,900	12,900	12,500	-	-	-	-	-	-	-	13,000	12,600	12,700	12,300	12,700	12,300	12,400	12,000	-	-	-	-	
DI Turbo	4.10	20,000	-	-	12,900	12,500	-	-	-	-	-	-	-	-	-	12,700	12,300	-	-	-	-	-	-	-	-	
Diesel	4.88	26,000	-	-	-	-	18,300	18,000	18,300	17,900	-	-	-	-	-	-	-	-	-	-	-	-	-	-	-	

### Maximum Loaded Trailer Weight (Lbs.) – Manual Transmission

ENGINE	AXLE RATIO	GCWR (LBS.)	Regular Chassis Cab							Super Chassis Cab				Crew Chassis Cab											
			F-350 4x2 SRW	F-350 4x4 SRW	F-350 4x2 DRW	F-350 4x4 DRW	F-450 4x2 DRW*	F-450 4x4 DRW*	F-550 4x2 DRW*	F-550 4x4 DRW*	F-350 4x2 SRW	F-350 4x4 SRW	F-350 4x2 DRW	F-350 4x4 DRW	F-350 4x2 SRW	F-350 4x4 SRW	F-350 4x2 DRW	F-350 4x4 DRW							
5.4L	3.73	13,500	7,500	7,000	7,100	6,700	-	-	-	-	-	-	-	7,100	6,700	6,900	6,500	6,800	6,400	6,600	6,200	-	-	-	-
SEFI V8	4.10	15,000	9,000	8,500	8,600	8,200	-	-	-	-	-	-	-	8,600	8,200	8,400	8,000	8,300	7,900	8,100	7,700	-	-	-	-
6.8L	3.73	16,500	10,300	9,900	9,900	9,500	-	-	-	-	-	-	-	10,000	9,600	9,700	9,300	9,700	9,300	9,400	9,000	-	-	-	-
SEFI V10	4.30	20,000	13,800	13,400	13,400	13,000	-	-	-	-	-	-	-	13,500	13,100	13,200	12,800	13,200	12,800	12,900	12,500	-	-	-	-
	4.88	22,00																							

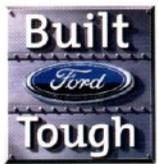

Visit the Ford website at [www.ford.com](http://www.ford.com)